

ORGANIC RANKINE CYCLE AS EFFICIENT ALTERNATIVE TO STEAM CYCLE FOR SMALL SCALE POWER GENERATION

Vankeirsbilck I.¹, Vanslambrouck B.*¹, Gusev S.¹, De Paepe M.²

*Author for correspondence

¹ Department Electromechanics, Research Group of Thermodynamics

Howest, University College of West-Flanders

Kortrijk, 8500,

Belgium

² Department of Flow, Heat and Combustion Mechanics

Ghent University-UGent

Ghent, 9000,

Belgium

E-mail: Bruno.Vanslambrouck@howest.be

ABSTRACT

To generate electricity from biomass combustion heat, geothermal wells, recovered waste heat from internal combustion engines, gas turbines or industrial processes, both the steam cycle and the organic Rankine cycle are widely in use. Both technologies are well established and can be found on comparable industrial applications. This paper presents a thermodynamic analysis and a comparative study of the cycle efficiency for a simplified steam cycle versus an ORC cycle. The most commonly used organic fluids have been considered : R245fa, Toluene, (cyclo)-pentane, Solkatherm and 2 silicone-oils (MM and MDM). Working fluid selection and its application area is being discussed based on fluid properties. The thermal efficiency is mainly determined by the temperature level of the heat source and the condenser conditions. The influence of several process parameters such as turbine inlet and condenser temperature, turbine isentropic efficiency, vapour quality and pressure, use of a regenerator (ORC), is derived from numerous computer simulations. The temperature profile of the heat source is the main restricting factor for the evaporation temperature and pressure. Finally, some general and economic considerations related to the choice between a steam cycle and ORC are discussed.

INTRODUCTION

The generation of power using industrial waste heat has been growing in the past years. Due to the increasing energy prices, it is becoming more and more economically profitable to recover even low grade waste heat. An often used solution is

the transformation of waste heat into electricity. For this a conventional steam turbine is a classic option. The waste heat is used to produce steam that is being expanded over the turbine to generate electricity.

NOMENCLATURE

<i>BP</i>	[°C]	Boiling point
<i>E_{evap}</i>	[kJ/kg]	Evaporation heat
<i>h</i>	[kJ/kg]	Enthalpy
<i>HMDS</i>	[-]	Hexamethyldisiloxane
<i>MW</i>	[kg.mol]	Molar weight
<i>OMTS</i>	[-]	Octamethyltrisiloxane
<i>p</i>	[bar]	Pressure
<i>P</i>	[kW]	Power
<i>q</i>	[%]	Vapour quality
<i>s</i>	[kJ/kgK]	Entropy
<i>T</i>	[°C]	Temperature

Special characters

η	[%]	Efficiency
η_i	[%]	Isentropic efficiency
$\eta_{m,e}$	[%]	Overall efficiency

Subscripts

bto	Gross
cond	Condenser
crit	Critical
evap	Evaporation
gen	generator
in	Inlet
nto	Net
reco	Recoverable
sup	Superheating
th	Thermal

A drawback to the use of steam is often the limited temperature level of the waste heat source. This puts a constraint on the maximum superheating temperature and the evaporation pressure of the generated steam, and thus restricts the achievable electric efficiency of this power cycle.

Another possible solution, based on the same technology, is the use of an organic Rankine cycle (ORC). This system uses the same components as a conventional steam power plant – a heat exchanger, evaporator, expander and condenser – to generate electric power. In the case of an ORC however, an organic medium is used as a working fluid instead of water/steam. These organic fluids have some interesting characteristics and advantages compared to a water/steam system [1-4]. Most of these organic fluids can be characterized as “dry” fluids, which implies that theoretically no superheating of the vapour is required. These fluids can be used at a much lower evaporation temperature and – pressure than in a conventional steam cycle, and still achieve a competitive electric efficiency or perform even better at low temperatures.

Today, standard ORC-modules are commercially available in the power range from few kW up to 3 MW. This technology has been proven and successfully applied for several decades in geothermal, solar and biomass fired CHP plants. Also in the industry there is a lot of waste heat available, often on low temperature levels and on small to moderate thermal power scale. The objective of this paper is to evaluate and compare the performance of a classic steam cycle and an organic Rankine cycle for small and low temperature heat sources.

ORGANIC WORKING FLUIDS

To evaluate the characteristics of several organic fluids in this study, we used the simulation software Fluidprop

[5] and Cycle Tempo [6] developed at Technical University of Delft, The Netherlands. The following commonly used organic fluids have been considered : R245fa, Toluene, (cyclo)-pentane, Solkatherm and the silicone-oils MM and MDM. Table 1 presents some thermo-physical properties for these organic fluids and water.

From Table 1 it can be derived that the critical pressure, and thus the operating pressure at the inlet of the turbine in an ORC (subcritical) system, is much lower than in the case of a classical steam cycle in a power plant. Although there are steam turbines that work with low pressure steam, the thermal efficiency of a steam cycle also decreases with lower turbine pressure.

All of the above organic fluids are “dry” fluids. Dry fluids are characterized by a positive slope of the saturated vapour curve in a T-s diagram. Water on the other hand is a “wet”

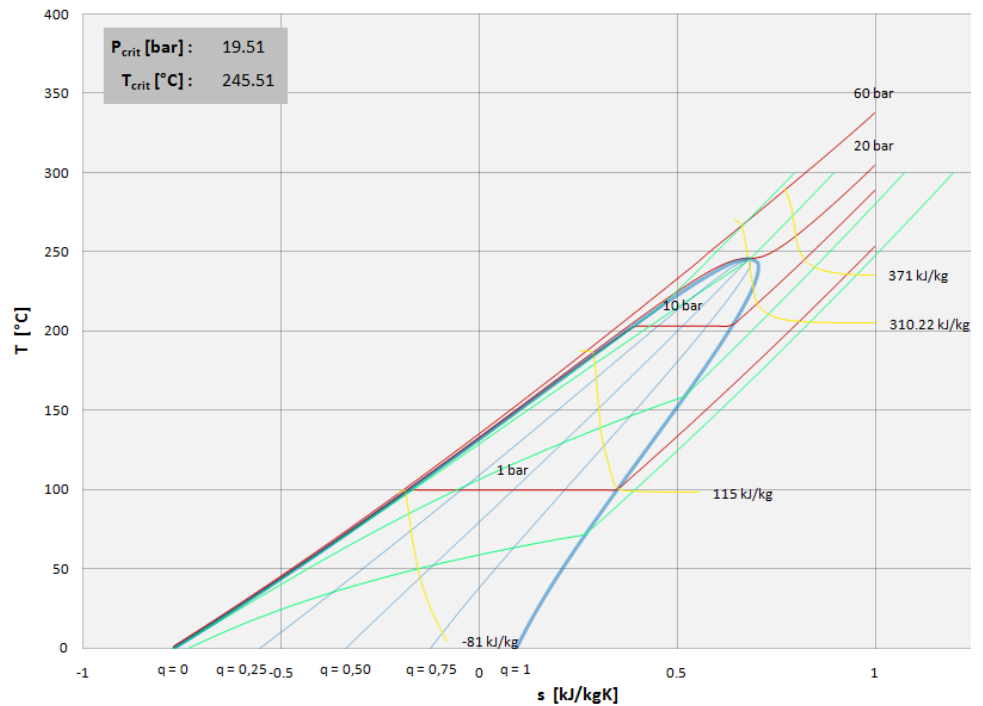

Figure 1 : T-s diagram silicone oil MM

Table 1 : Thermo-physical properties of water and ORC fluids

Fluid	Formula/ name	MW [kg/mol]	T _{crit} [°C]	p _{crit} [bar]	BP [°C]	E _{evap} [kJ/kg]
Water	H ₂ O	0.018	373.95	220.64	100.0	2257.5
Toluene	C ₇ H ₈	0.092	318.65	41.06	110.7	365.0
R245fa	C ₃ H ₃ F ₅	0.134	154.05	36.40	14.8	195.6
n-pentane	C ₅ H ₁₂	0.072	196.55	33.68	36.2	361.8
cyclopentane	C ₅ H ₁₀	0.070	238.55	45.10	49.4	391.7
Solkatherm	solkatherm	0.185	177.55	28.49	35.5	138.1
OMTS	MDM	0.237	290.98	14.15	152.7	153.0
HMDS	MM	0.162	245.51	19.51	100.4	195.8

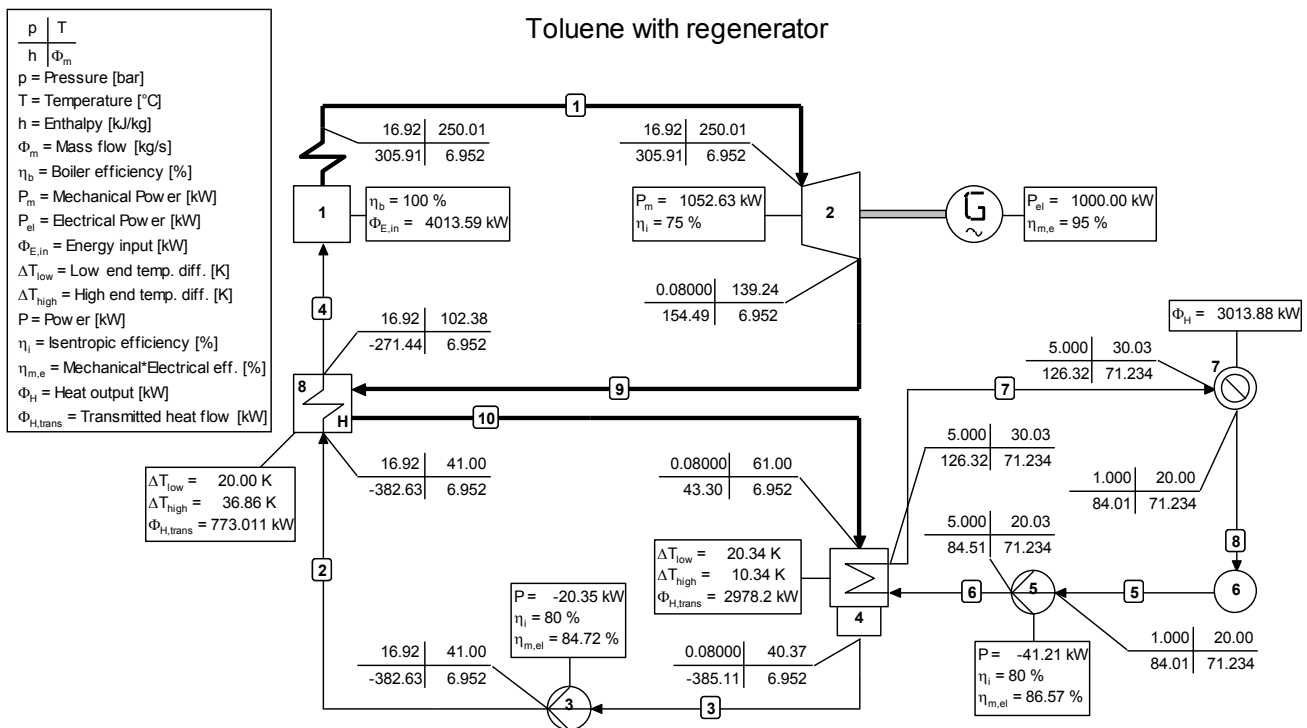

Figure 2 : Diagram ORC with regenerator

fluid, with a negative slope. In Figure 1 the T-s diagram for the silicone-oil MM is presented. Dry fluids do not need to be superheated and thus saturated vapour can be applied in an ORC expander. After expansion the working fluid remains in the superheated vapour region. In contrast, in a steam cycle the steam is usually superheated to avoid moisture formation in the

final turbine stages. This has an impact on the performance and durability of the steam turbine.

The higher the boiling point of a fluid, the lower the condensation pressure at ambient temperature is expected to be. This leads to lower densities and higher specific volumes after expansion. For water/steam this results in big diameters for the final turbine stages and a voluminous condenser. Organic fluids have a 10 times higher molar weight or density, and therefore require smaller turbine diameters. However, the evaporation heat of organic fluids is also 10 times smaller compared to water/steam. This results in higher mass flows in the ORC-cycle, and so much bigger feed pumps are needed compared with a steam cycle.

As a conclusion, all these thermo-physical properties will have a effect on the design and complexity of the heat exchangers, turbine and condenser and have to be considered during a economic analysis and comparison.

ORC VERSUS STEAM CYCLE

Organic Rankine cycle

Figure 2 shows a diagram, made with the simulation program Cycle Tempo [6], of an ORC with toluene as working fluid and with a

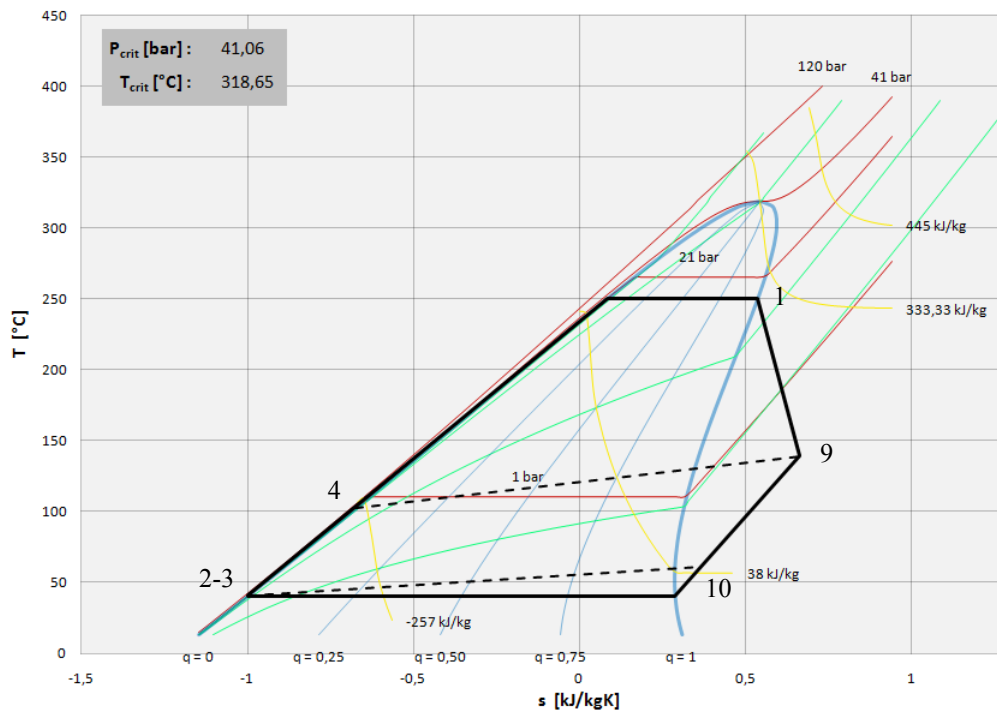

Figure 3 : T-s diagram of ORC with toluene

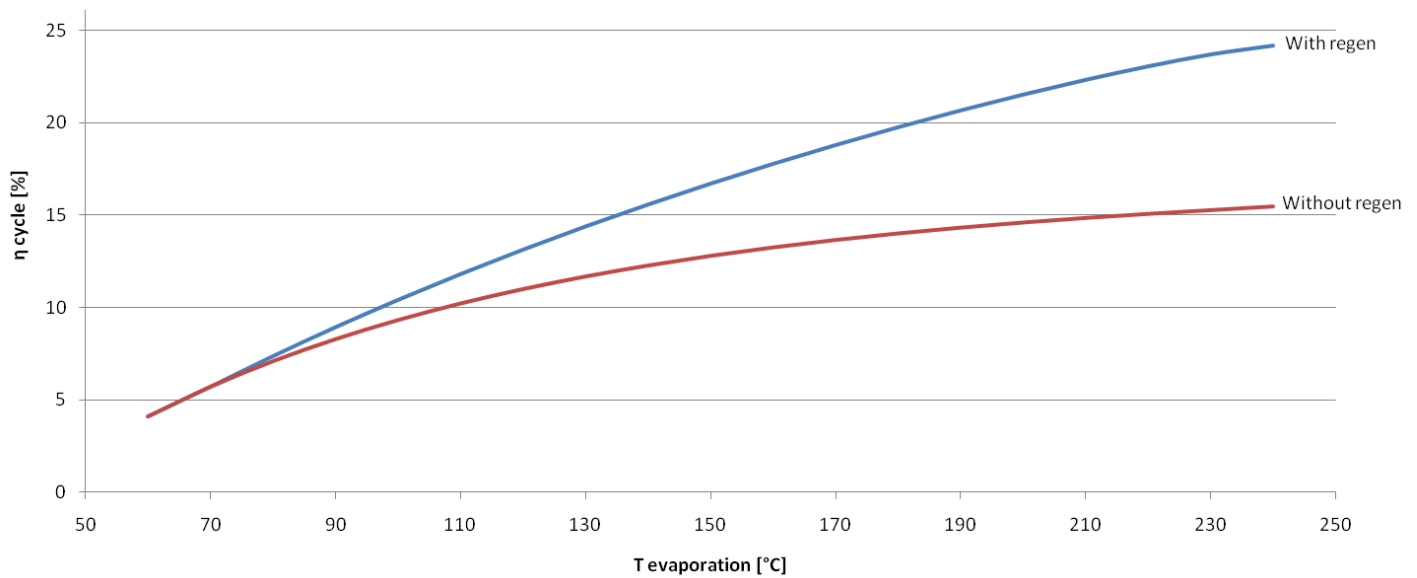

Figure 4 : Influence regenerator on cycle efficiency for MM

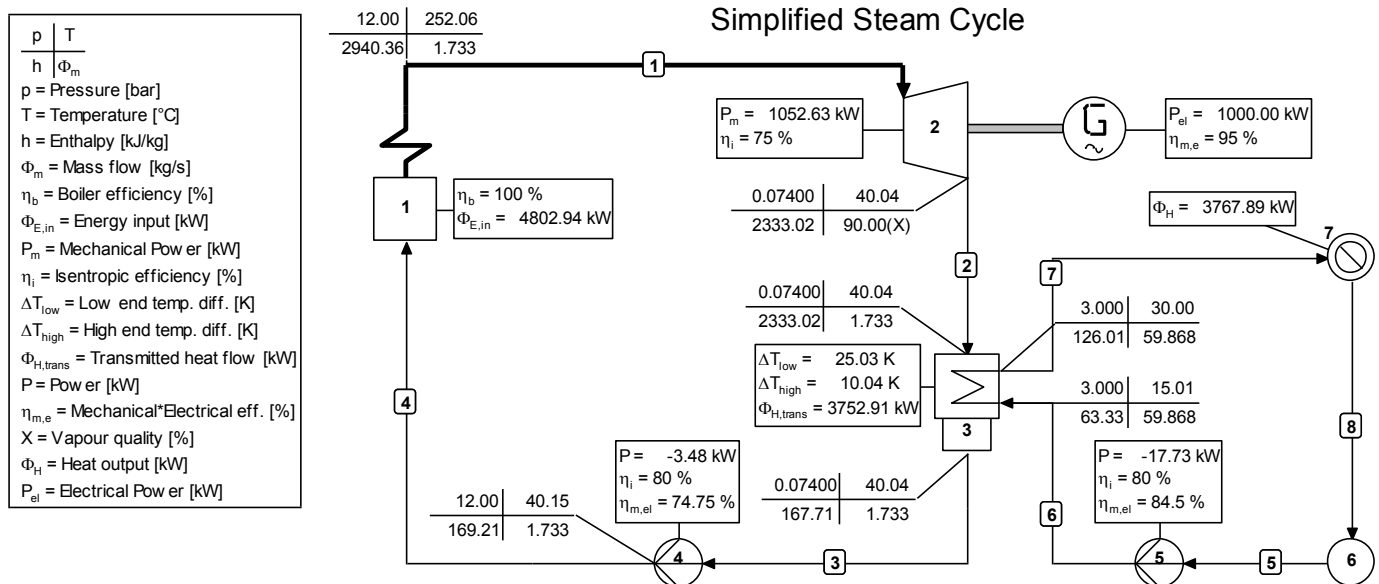

Figure 5 : Diagram simplified steam cycle

regenerator. The corresponding cycle in a T-s diagram is shown in Figure 3. A regenerator is often used to reach a higher cycle efficiency. After expansion the organic fluid remains considerably superheated above the condenser temperature. This sensible heat can be used to preheat the organic liquid in a heat exchanger after the condenser. The higher the evaporation temperature, the higher the influence of a regenerator on the cycle efficiency. Figure 4 shows the effect of the regenerator on the cycle efficiency for the silicone-oil MM (considering a condenser temperature of 40°C).

Simplified steam cycle

Figure 5 shows the simplified steam cycle without deaerator used as a reference for the comparison with the ORC-cycle. Although the diagram of the simplified steam cycle looks very similar to the one of a ORC without regenerator, there is one important difference. Whereas ORC-cycles can be applied with saturated vapour, a classic steam cycle usually works with superheated steam. Although there are also steam turbines available that can work with saturated steam, but normally these turbines have a very poor isentropic efficiency.

The in- and outlet conditions of a steam turbine are correlated to each other by its isentropic efficiency. This implies that for each evaporation pressure there exists a

Table 2 : ORC and steam cycle data

Cycle data		
Isentropic efficiency turbine	[%]	75
Pump efficiency	[%]	80
T_{cond}	[°C]	40
q steam outlet turbine	[%]	90
Inlet turbine ORC		Saturated
Inlet turbine steam		Superheated
T_{in} turbine	[°C]	60-500

minimum superheating temperature so that a prescribe vapour quality at the turbine's outlet is reached.

In this present study the simplified steam cycle is compared with an ORC-cycle with and without regenerator. In a next step the model of the steam cycle will be refined with an deaerator which has a minor positive influence on cycle efficiency.

Calculation assumptions and results

The above discussed ORC- and steam cycle are applicable to all the analysis shown in this paper. The performance is evaluated for stationary conditions of all components with the following general assumptions and data in Table 2.

To compare cycles using wet and dry fluids with each other, the optimized cycle between predefined temperature levels of the heat source and condenser is considered for each case. In this part of the study the assumption is made of a heat source at

a constant temperature level that also defines the turbine's inlet temperature. This implies that only cycles with the same temperature level at inlet and outlet of the turbine are compared. Further in this paper the analysis is refined with a predefined temperature profile of the heat source and an optimized turbine inlet pressure to make best possible use of the available heat.

Mass and energy conservation is applied to each cycle component, and no pressure and energy losses are taken in to account. Figure 6 shows the reached cycle efficiency as a function of the turbine inlet temperature for all considered fluids. Below ca 130°C it's impossible to reach the predefined turbine outlet conditions for the considered steam cycle.

From the graphs in Figure 6 can be concluded that :

- ORC's have a better performance than a simplified steam cycle with the same inlet temperature at the turbine.
- The (theoretically) highest performance is achieved for an ORC with toluene.
- The application area of ORC's on current working fluids is limited to temperatures below 300°C (without superheating).

Some remarks and considerations should be made to previous study :

- In practice, different kinds of expanders (turbine, screw expander,...) are used in ORC's. Depending on the kind of expander isentropic efficiencies of 85 – 90% are realistic for turbines with a dedicated design.
- The efficiency of small scale steam turbines for low pressure applications with limited superheating temperature was found to be lower than 75% in practice.
- The efficiencies of commercially available ORC's may be

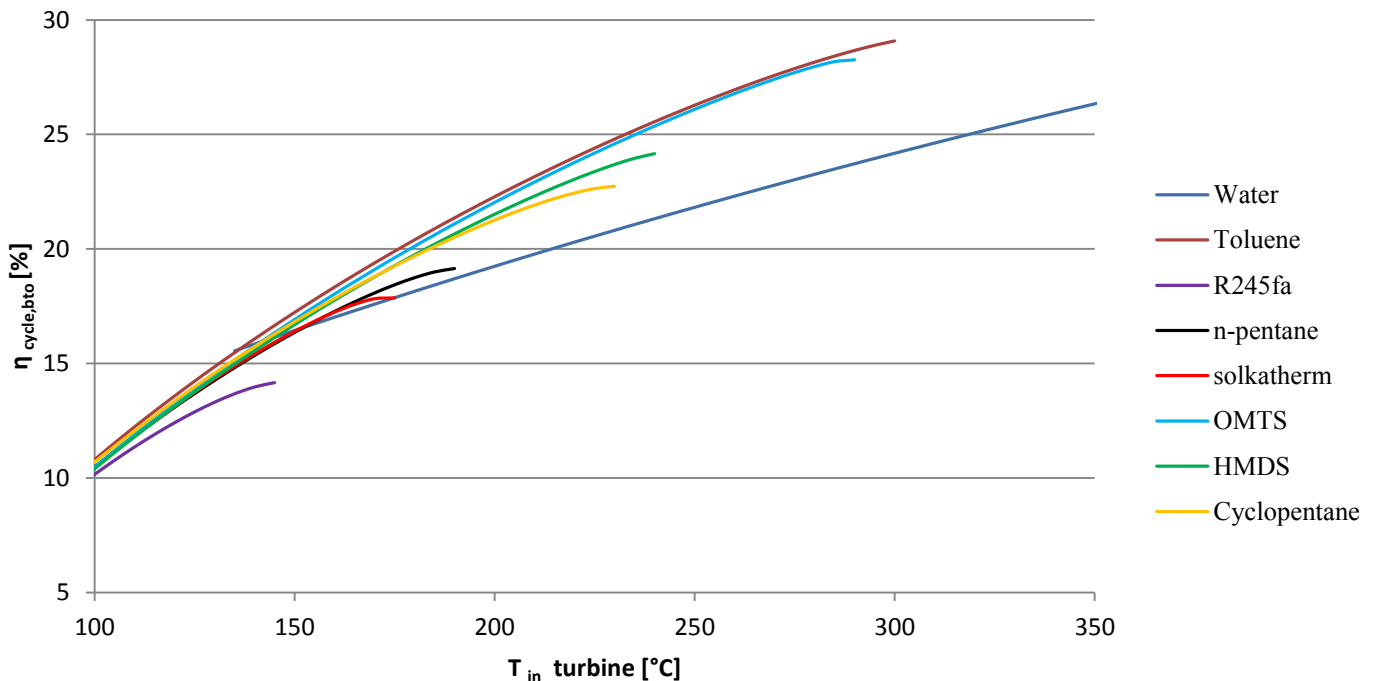

Figure 6 : Cycle efficiency as function of turbine inlet temperature

lower, depending on the correspondence of the installation with the assumptions made in this study (pressure and temperatures at the inlet and outlet of turbine and isentropic efficiency).

INFLUENCE TEMPERATURE PROFILE HEAT SOURCE

In reality the temperature of a waste heat source does not remain at a constant level, but has a given temperature profile. This profile defines the thermal power P_{th} available between inlet – and outlet temperatures, and is function of the mass flow and medium type of the heat source. The

Table 3 : Data case study temperature profile heat source

Parameter data			
Waste Heat source :		Components	
T profile	350 – 120 °C	η_i pump	80%
P_{th}	3000 kW _{th}	$\eta_{m,e}$ pump	90%
Pinch	20°C	$\eta_{m,e}$ generator	90%
ORC-cycle		Simplified steam cycle	
medium	HMDS	T_{cond}	40°C
ΔT_{sup}	10°C	η_i turbine	70 – 80%
T_{cond}	40°C	q	93%
η_i turbine	70 – 80%	ΔT_{sup}	=f(p_{evap} , T_{cond} , q, η_i turbine)

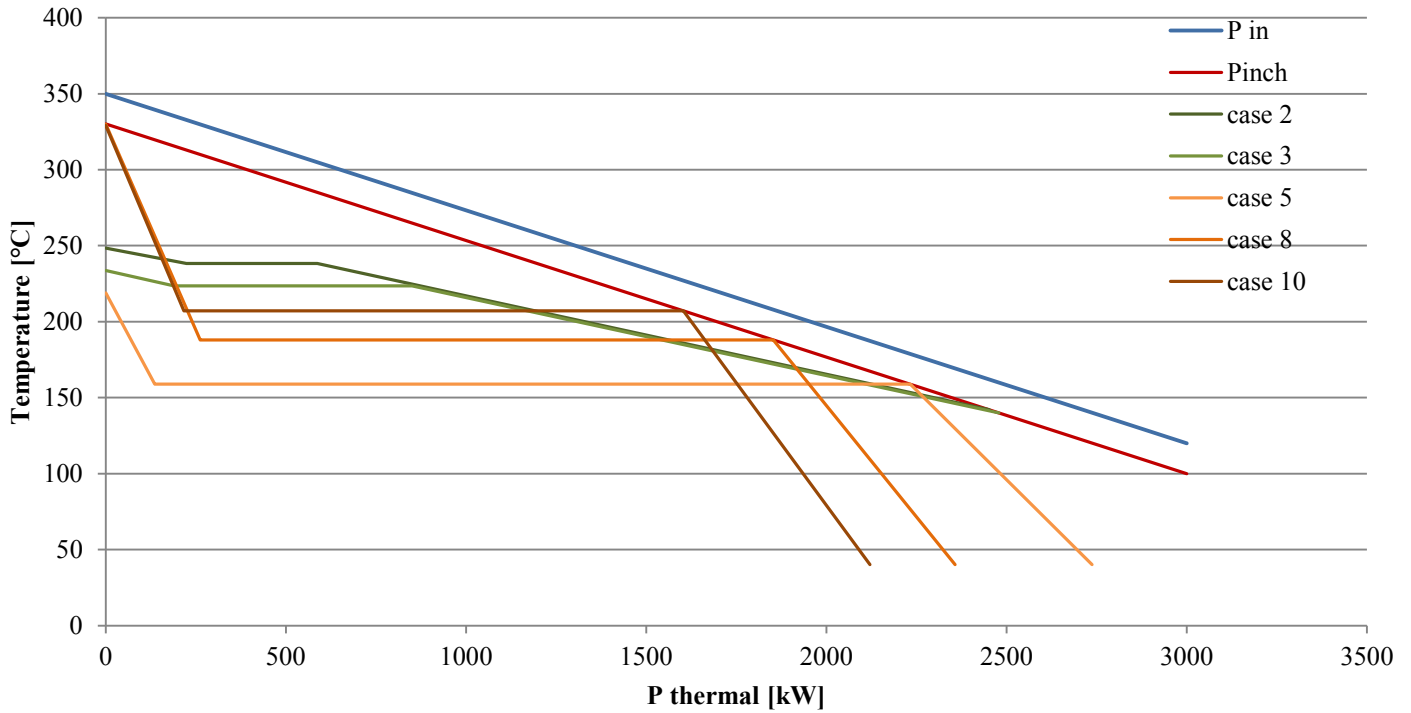

Figure 7 : Heating profile ORC and steam cycle

Table 4 : Results case study temperature profile heat source

		ORC with regenerator				Simplified steam cycle					
		17.6	14	6	12	18					
p_{evap}	[bar]	70	80	70	80	70	80	70	80	70	74
η_i turbine	[%]	248	248	234	234	219	267	272	330	305	329
T_{sup}	[°C]	2388	2452	2479	2540	2737	2715	2386	2357	2134	2121
$P_{th, reco}$	[kW _{th}]	509	578	506	574	440	509	442	509	426	450
$P_{gen, bto}$	[kW _e]	21.3	23.6	20.4	22.6	16.1	18.7	18.5	21.6	19.9	21.2
$\eta_{cycle, bto}$	[%]	487	556	488	556	439	508	441	508	424	449
$P_{gen, nto}$	[kW _e]	20.4	22.7	19.7	21.9	16.0	18.7	18.5	21.5	19.9	21.2
$\eta_{cycle, nto}$	[%]	1	2	3	4	5	6	7	8	9	10
Case											

closer the heating curves (preheating – evaporation – superheating) of the cycle fits this temperature profile, the more efficient the waste heat will be used and transformed by the ORC- or steam cycle. In this part of the paper simulations are made for an arbitrary temperature profile of the waste heat source. Table 3 shows the general data for this case study.

The calculations and design of the heat exchangers to recover the industrial waste heat are not in scope of this study. As a start, the effectiveness of the heat exchangers is taken into account by defining a pinch line with a minimum offset of 20°C temperature difference to the profile of the waste heat source. The achievable superheating temperature for the simplified steam cycle is function of p_{evap} , q , T_{cond} , η_i turbine, and is limited to this pinch line.

Table 4 shows the results for the gross and net generator power and the cycle efficiency η . The net generator power is calculated as : $P_{gen,nto} = P_{gen,bto} - P_{pump}$. Depending on p_{evap} and T_{sup} , only part of the thermal energy of the heat source can be recovered $P_{th, reco}$. In Figure 7 the heating profile for some selected cases of table 4 are represented. As can be seen in this figure, the pinch point for the ORC-cycle is determined by the temperature after the regenerator. For the steam cycle the selected evaporation pressure or the superheating temperature are the constraining variables. Because the evaporation heat E_{evap} for organic fluids is much smaller than for water, a higher evaporation temperature can be selected and less thermal energy on a higher level is required in an ORC. This results in

a higher cycle efficiency η and in a 10 to 15% higher electric power generation for an ORC-cycle in this case study.

COMBINED STEAM CYCLE WITH BOTTOMING ORC CYCLE

Also in this research project, a preliminary evaluation has been made of a condensing steam cycle compared to a combined backpressure steam cycle with a bottoming ORC. Figure 8 shows a diagram for such a combined steam cycle and ORC with MM as a working fluid.

An optimized backpressure steam cycle has the advantage of a smaller pressure ratio and therefore a less complex turbine design with smaller final diameter. In addition, a lower superheating temperature is required compared to a condensing steam cycle with the same evaporation pressure, allowing a combined cycle to be applied on a waste heat source with a relatively low temperature level. Further evaluation of the performance of this combined steam cycle-ORC to a waste heat source with a predefined temperature profile is still in progress.

Bottoming ORC's have previously been proposed by Chacartegui et al. for combined cycle power plants [7] and by Angelino et al. to improve the performance of steam power stations [8].

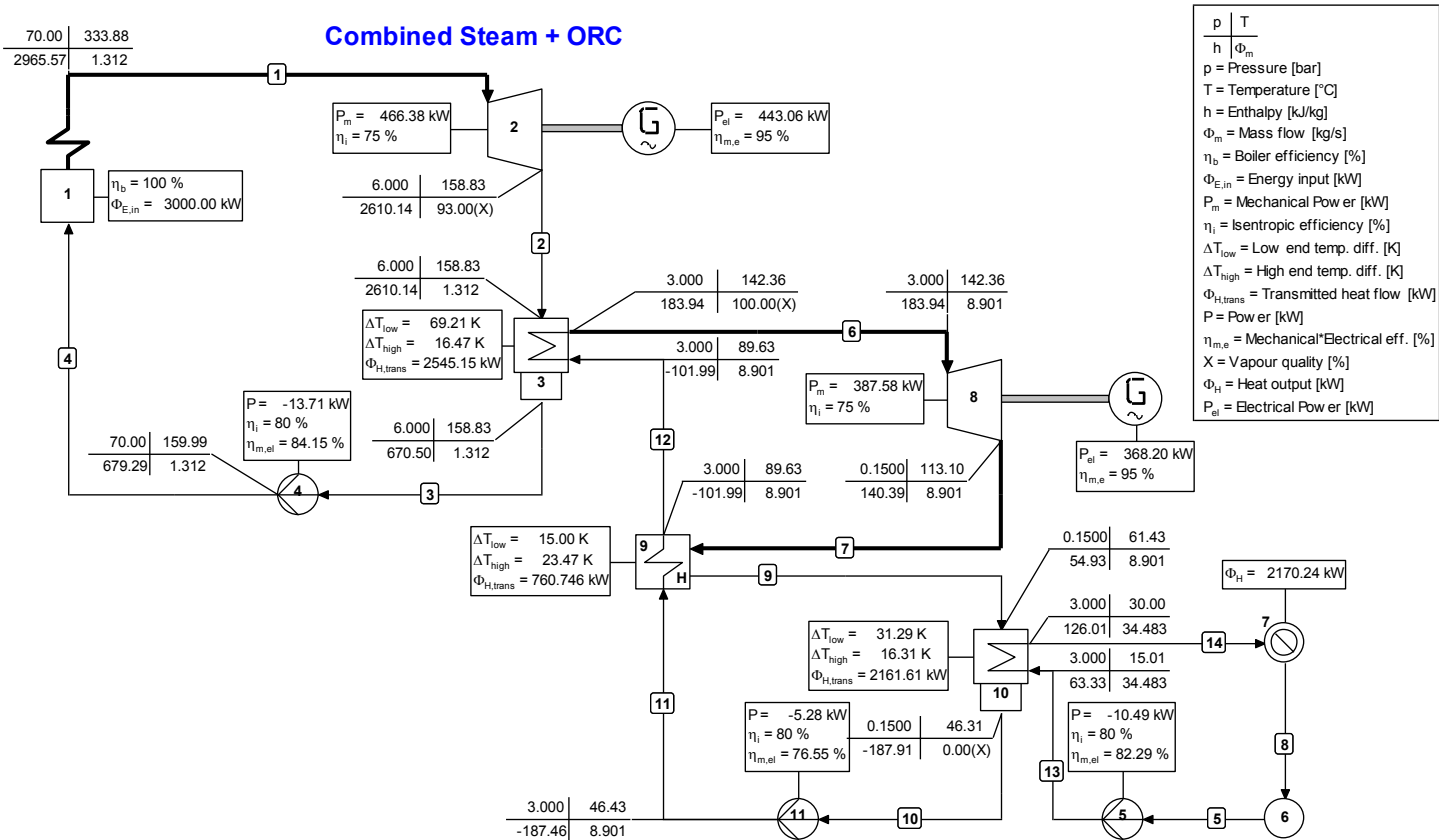

Figure 8 : Combined backpressure steam cycle with bottoming ORC-cycle

SELECTION ARGUMENTS

From literature studies, extensive experience and shared knowledge with constructors, suppliers and operators of both steam cycle and ORC based power plants, some general and experience based arguments are listed that should be considered in the selection between a steam cycle and an ORC. These considerations should be translated into an investment -, maintenance - and exploitation cost.

Pro ORC:

- Most organic fluids applied in ORC installations are dry fluids and do not require superheating. An important factor in the total cost is the design and dimensions of the heat exchangers (preheater – evaporator – superheater) for the waste heat recovery. Superheater dimensions usually are big because of the lower heat transfer pro surface unit for a gaseous medium.
- The isentropic efficiency of the turbine varies with its power scale and its design. In general ORC expanders with a dedicated design have a higher efficiency than small scale steam turbines in the same power range.
- No need of accurate process water treatment and control, nor deareator
- Less complex installation, very favourable when starting from green field or when there is no steam network with appropriate facilities already present on site.
- Very limited maintenance costs and a high availability
- Very easy to operate (only start-stop buttons)
- Good part load behaviour and efficiency
- Much lower system pressure, less stringent safety legislation applicable
- No need of a qualified operator
- Available with electrical outputs from 1 kWe (or even less). Even though small scale (f.i. 10 kW) steam turbines are available, steam turbines only become profitable on higher power outputs (above 1 MWe)

Pro steam cycle:

- Water as a working fluid is cheap and widely available, while ORC fluids can be very expensive or their use can be restricted by environmental arguments. Also large on-site steam networks, which require high amounts of working fluid (steam), are possible.
- More flexibility on power/heat ratio (important on biomass fired CHP's) by using steam extraction points on the turbine and/or back pressure steam turbines.
- Direct heating and evaporation possible in (waste) heat recovery heat exchangers, no need of an intermediate (thermal oil) circuit.
- Some standard ORC's are designed to work with an intermediate thermal oil circuit to transport the waste heat to the ORC preheater and evaporator. This way less ORC fluid is required, but this tends to make the installation more complex and expensive, causes a supplementary temperature drop and some fire accidents with thermal oil circuits are known.

CONCLUSIONS

The main conclusions drawn from this paper are the following :

- ORC's can be operated on low temperature heat sources with low to moderate evaporation pressure, and still achieve a better performance than a steam cycle.
- ORC's require bigger feed pumps, because of a higher mass flow, which has a higher impact on the net electric power.
- The heating curves of ORC's can be better fitted to match the temperature profile of waste heat sources, resulting in a higher cycle efficiency and in a higher recovery ratio for the thermal power $P_{th, reco}$.
- A combined steam cycle with a bottoming ORC cycle can be used for a closer fit to the temperature profile of a waste heat source on moderate temperature levels. Cost effectiveness of such combined cycles still needs further investigation.

ACKNOWLEDGEMENTS

The authors wish to acknowledge the financial support of IWT Flanders to this work (IWT is the government agency for Innovation by Science and Technology).

Also the support and the use of the simulation software Fluidprop and Cycle Tempo, developed by Delft University of Technology, The Netherlands is gratefully acknowledged.

REFERENCES

- [1] P.J. Mago, L.M. Chamra, K. Srinivasan, C. Somayaji, 2008, "An examination of regenerative organic Rankine cycles using dry fluids", Applied Thermal Engineering, vol. 28, Jun. 2008, p. 998—1007.
- [2] T. Hung, 2001, "Waste heat recovery of organic Rankine cycle using dry fluids", Energy Conversion and Management, vol. 42, Mar. 2001, p. 539—553.
- [3] B. Liu, K. Chien, en C. Wang, 2004, "Effect of working fluids on organic Rankine cycle for waste heat recovery", Energy, vol. 29, Jun. 2004, p. 1207—1217.
- [4] G. Angelino, P. Colonna di Paliano, 1998, "Multi-component Working Fluids For Organic Rankine Cycles (ORCs)", Energy, vol. 23, Jun. 1998, p. 449—463.
- [5] P. Colonna, T.P. van der Stelt, 2004, FluidProp: a program for the estimation of thermo physical properties of fluids, Energy Technology Section, Delft University of Technology, The Netherlands (www.FluidProp.com).
- [6] Simulation software Cycle-Tempo Website: <http://www.Cycle-Tempo.nl>
- [7] Chacartegui R., Sánchez D., Muñoz J.M., Sánchez T., 2009, "Alternative ORC bottoming cycles for combined cycle power plants.", Applied Energy, vol. 86, 2009, p. 2162 – 2170
- [8] Angelino G., Invernizzi C, Molteni G, 1999, "The potential role of organic bottoming Rankine cycles in steam power stations.", Proceedings of the Institution of Mechanical Engineers : A journal of power and energy, vol. 213, 1999, No A2, p. 75 – 81