



Titanium production via metallothermic reduction of TiCl_4 in molten salt: problems and products

by D.S. van Vuuren*, S.J. Oosthuizen*, and M.D. Heydenrych†

Synopsis

Industrial production of titanium occurs via the batch-wise reduction of titanium tetrachloride (TiCl_4) with a reducing metal, being magnesium in the Kroll process, or sodium in the Hunter process. In the search for low cost titanium, the CSIR is developing a continuous process to produce titanium powder directly via metallothermic reduction of TiCl_4 in molten salt, dubbed the CSIR-Ti process.

The move to a continuous process has been attempted by a number of organizations, but was until now always met with failure, due in no small part to challenges inherent in the process chemistry. The reaction between TiCl_4 and the reducing metal can occur directly, when TiCl_4 or any titanium sub-chlorides present, comes into contact with suspended or dissolved reducing metal. The reaction can also occur indirectly, without any physical contact between the reacting species, via an electronically mediated mechanism. The reaction mechanism via electronic mediation can cause TiCl_4 to react at the outlet of the feed port, rapidly causing blockages of the TiCl_4 feed line. The electrical conductivity of the metal reactor can also cause the electronically mediated reaction to favour the formation of titanium sponge on the reactor walls and internals, rather than titanium powder.

Various methods were investigated to overcome the problem of blockages in the TiCl_4 feed line, e.g. mechanical removal, sonic velocities, dilution of the TiCl_4 and the use of ceramic feed lines.

This article discusses problems experienced with the continuous feeding of reagents, and various methods attempted are shown and discussed. Information is also given on the morphology, chemical composition and suitability of the final titanium powder for powder metallurgical application as presently produced by the CSIR-Ti process.

Keywords

Titanium dioxide, titanium nitride, carbo-thermic reduction, ilmenite, slag, tunnel kiln, residence time.

Introduction

Titanium and its alloys exhibit very attractive properties, such as low density, high strength, and good corrosion resistance, properties that are exceptionally useful in various applications ranging from aerospace to sporting goods. Titanium metal costs are, however, high when compared to e.g. stainless steel, due to costly batch manufacturing via the industry standard Kroll process and processing steps that often include double vacuum arc remelting (VAR) to get to usable metal. A route producing low cost

titanium metal powder would enable significant market share to be taken up by titanium from stainless steel.

Presently titanium powders are typically made by gas atomization or plasma rotating electrode (PREP) processes. Titanium powder is also made by a reversible hydride-dehydride (HDH) process in which titanium metal sponge, billet, scrap or machining chips are heated in hydrogen to form brittle titanium hydride, which is crushed and then reconverted to titanium metal powder. All three methods make use of titanium as a starting material and, by merely adding processing costs to existing material costs, such powders are expensive.

Following consideration of various options to produce titanium and a critical evaluation of the routes to produce primary titanium metals, the CSIR concluded that the most promising route to produce primary titanium is continuous production of titanium powder by metallothermic (alkali or alkali earth metal) reduction of TiCl_4 in molten salt formed as a consequence of the reaction¹. In this report, the laboratory-scale work undertaken at the CSIR to develop such a process in a molten salt mediated reactor is described.

The crux of the economic assessment of the process follows from the premises that:

- Assuming similar yields, continuous, direct production of titanium powder by metallothermic reduction of TiCl_4 would be cheaper than batch-wise production of titanium sponge by the same metallothermic reduction of TiCl_4 because of a significant reduction in, especially, labour costs².

* *Materials Science and Manufacturing, CSIR, Pretoria.*

† *Department of Chemical Engineering, University of Pretoria.*

© *The Southern African Institute of Mining and Metallurgy, 2011. SA ISSN 0038-223X/3.00 + 0.00. This paper was first presented at the, Light Metals Conference, 27-29 October 2010, Misty Hills, Muldersdrift.*

Titanium production via metallothermic reduction of TiCl_4 in molten salt

- ▶ Titanium powder is potentially much more valuable than titanium sponge because many titanium products can be produced directly from titanium powder using powder metallurgical techniques, thus avoiding costs associated with melting and milling titanium^{3,4}.

Based on the success achieved to date and confirmation of the economic viability of the process, detailed planning up to a pilot scale (*ca.* 2 kg/h Ti) is currently in progress.

Experimental

Initial experiments for the CSIR-Ti process were completed using a continuous stirred tank reactor (CSTR), as illustrated in Figure 1, being a sketch of the reactor used, and Figure 2 a photograph. The reactor has the capacity to produce 400–500 g of titanium powder per experiment. In order to conserve the relatively costly reagents during multiple experiments, for the majority of experiments the amount of titanium to be produced was limited to 200 g. This amount of titanium powder is enough for complete post-production analysis and powder/product characterization. To limit any problems with sealing at high temperature, the reactor lid was welded onto the reactor and after every completed experiment, the reactor was cut open, the product removed and any changes to internals made, and then welded shut again.

The reactor was loaded with 3–4 kg of an alkali metal chloride salt. As the salt can be very hygroscopic it was pre-dried at 150°C for more than 6 hours. The reactor was placed in a vertical tube furnace and heated to reaction temperature above the melting point of the relevant salt, after which the reducing alkali metal and TiCl_4 were added using various methods, described in detail in the following section. Part of

the piping shown in the photograph served as a TiCl_4 evaporator and the vertical tube as port to feed granules or the reducing alkali metal.

Following an experiment, the reactor was allowed to cool down to room temperature prior to opening. The solidified mass of salt was removed by aqueous leaching to recover the

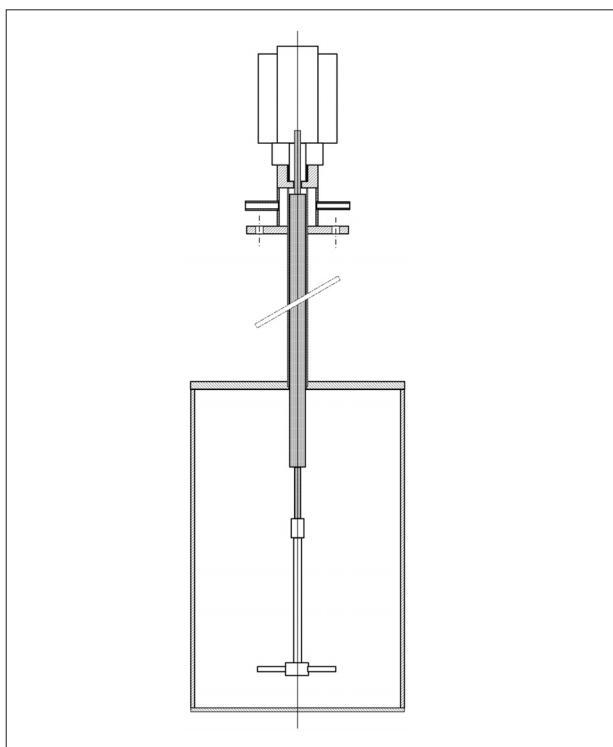

Figure 1—Drawing of the reactor



Figure 2—Photograph of reactor

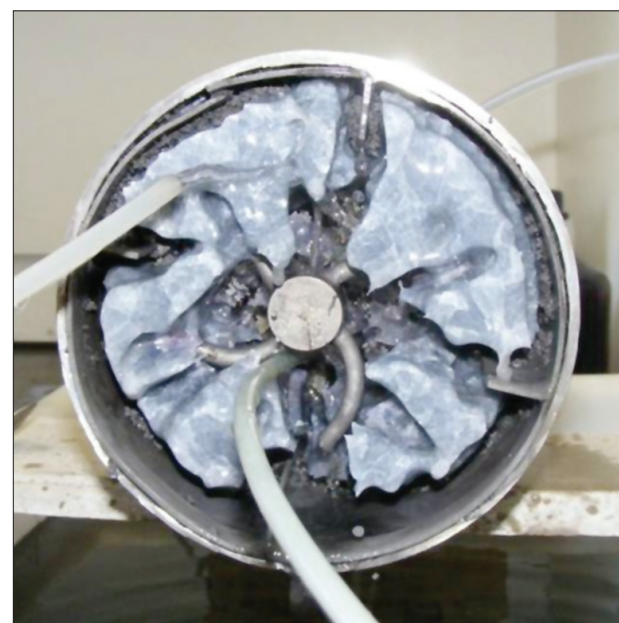

Figure 3—Leaching of reactor contents

Titanium production via metallothermic reduction of TiCl_4 in molten salt

titanium metal powder produced. As a slight stoichiometric excess of reducing metal was added, caution was taken during leaching as alkali and alkali earth metals react vigorously with water. The reactor headspace was flushed with argon, followed by slow addition of leach liquor, to limit the risk of fire and explosion

Following leaching, titanium powder product was collected by hand. Any fine powder in the leachate was captured by filtration, and combined with the mass of product from the reactor. The metal powder was washed repeatedly to remove as much residual salt as possible.

Experimental challenges

A multitude of experimental problems required solution, the most significant issue being related to the very fast reaction of the reagents, which caused line blockages—even without direct physical contact between the reagents.

To achieve good contact in the reactor between the molten reducing metal and TiCl_4 a 'gas pumping' stirrer, as can be seen in Figures 3 and 4, was suggested. The advantage of this type of impeller is that good gas dispersion can be achieved at relatively low stirrer speed. The stirrer shaft was hollow and had an inlet for gas above the molten salt level in the reactor. The stirrer impeller was made of four tubes, bent away from the direction of stirring in order to create suction through the hollow shaft, causing dispersion and recirculation of the TiCl_4 vapour through the liquid phase.

Cold tests with air and water indicated good mixing. However, under experimental conditions it was found that TiCl_4 was not being consumed by the reaction as expected, and loss of reagent in the off-gas was high. Following the experiment the reactor was opened and the salt leached. It was observed that the hollow tubes were blocked with titanium and the intended gas dispersion had failed. Titanium product on the surface of the salt, the stirrer shaft and also a thin film of titanium powder on the reactor walls above the molten salt interface was also observed.

It was then decided to feed the TiCl_4 directly into the molten salt near the stirrer, to further break and disperse the gas bubbles. The experiments failed virtually immediately after feeding of the TiCl_4 started because the feed line blocked. Upon opening and cleaning the reactor, a dense mass of titanium powder was found in the feed tube.

It was argued that TiCl_4 liquid might not have fully evaporated in the feed line entering the reactor hot zone. This could have the effect that liquid TiCl_4 , entering below the surface of the molten salt and rapidly boiling would cause a pressure disturbance, followed by salt being pushed up into the feed line. This may cause the feed line to plug with frozen salt, or to wet the inside of the line, where incoming TiCl_4 could react with the dissolved alkali metal in the salt to form a plug of titanium. To overcome the problem a TiCl_4 evaporator was installed, and argon was fed with the TiCl_4 vapour to effect gas movement and dilution of reagent. After the modifications, the results of the next experiment were virtually the same—the feed line blocked within seconds of starting the feed of TiCl_4 .

Literature on Japanese researchers' attempts to develop a continuous magnesiothermic titanium powder production process⁵ shed light on the cause of the problem. The

formation of titanium at the inlet can be caused by an electrochemical reaction between the reducing metal and the TiCl_4 , enabling these chemicals to react with each other without requiring physical contact. It was observed that the reactor wall (or stirrer shaft) can act as an anode for the metal oxidation reaction:

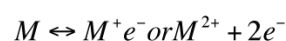

The electrons from the anodic reaction are then conducted along the metallic reactor wall to the tip of the TiCl_4 feed line where they reduce the TiCl_4 via the cathodic reaction:

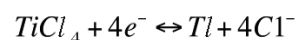

Figure 4—Blocked feed tube



Figure 5—Blocked ytria feed tube

Titanium production via metallothermic reduction of TiCl_4 in molten salt

The reactor system can then be likened to a battery, with the two reactions occurring at different electrodes, and the electrical path being completed by the metallic construction of the reactor and the salt bridge formed by the molten salt.

One way of overcoming this problem would be to feed TiCl_4 through a line that is made of a material that is not electrically conductive. Suzuki *et al.*⁵ reported the use of a magnesia tube to feed TiCl_4 , considerably delaying blocking of the line.

In order to test this concept, it was decided to install an alumina liner inside the feed line (a magnesia tube was not readily available). Nevertheless, the line also blocked, albeit later than achieved with metal feed lines only. Inspection of the alumina tube where it contacted the salt showed that it had been partially reduced to aluminium. The thermodynamics of the reaction between the reducing metal and alumina allows for the reduction to aluminium to take place.

In view of the partial improvement achieved for the duration of TiCl_4 feed before blockage occurred, it was decided to make the tip of the feed line from yttria, being the most resistant to attack by the reducing metal. A number of tests were done, but the results were essentially the same. The feed line blocked again, although after a slightly longer time. The blocked yttria tube was removed from the reactor, and split for inspection, as shown in Figure 5. It was surprising that the titanium blockage extended right into the yttria tube, where no reducing metal could have reached, and which was presumably also electrically insulated from the reducing metal in the reactor.

Winter⁶ patented an invention to reduce TiCl_4 continuously with molten magnesium that floats on top of a bath of stirred molten salt, which is contained in the vortex of the stirred bath created with a stirrer that enters the bath from the bottom. The molten magnesium is contained in the vortex and does not contact any part of the stirrer or reactor walls. It was decided not to pursue this solution to the problem because it was felt that the procedure is not robust enough for industrial processing. Furthermore such a process offers little freedom to make changes to the process conditions through which to manage titanium particle growth, since the TiCl_4 gas is brought into direct contact with a large mass of molten reducing metal.

White and Oden⁷ patented a molten salt process to produce titanium powder by sodiothermic reduction of TiCl_4 . Sodium dissolved in molten NaCl is mixed and reacted with TiCl_2 , dissolved in a separate stream of molten NaCl. The slurry of titanium powder is then split into three streams. The one stream is molten NaCl, which is used to dissolve sodium and then recycled to the reactor. The second stream consists of a slurry of titanium powder in molten salt and is reacted with TiCl_4 to produce TiCl_2 , dissolved in the NaCl. This stream is also recycled to the reactor. The last stream is the product stream from which titanium powder product is recovered. This approach is suitable for metallothermic reduction processes where the reducing metal has a relatively high solubility in the corresponding metal chloride such as sodiothermic and calciothermic reduction of TiCl_4 . It is totally unsuitable for magnesiothermic reduction of TiCl_4 because the solubility of magnesium in molten MgCl_2 is only about 0.2 mol%.

In a patent describing the Armstrong process⁸, the injection of TiCl_4 at sonic velocities into a stream of molten reducing metal is claimed. It was decided to attempt feeding TiCl_4 vapour at sonic velocity into the molten salt. Due to reactor constraints, it was decided to limit TiCl_4 feed to the reactor to 12 g/min. The nozzle size to appropriately limit the feed rate of TiCl_4 was approximately 0.3 mm in diameter.

Prior to completing reaction tests, sonic flow injection via the nozzle was visualized by feeding compressed argon into a 5 litre beaker containing water, a photograph of the test is shown in Figure 6. At sonic flow rates the gas momentum causes a plume extending horizontally across the beaker.

On trying to feed TiCl_4 into the reactor containing molten salt and reducing metal, the nozzle blocked within seconds following the switch of the feed from argon to TiCl_4 . As can be seen in Figure 7, titanium formed in the nozzle while TiCl_4 was flowing at sonic velocity.

Although the tests failed at this scale, it might be that on a larger scale sonic flow will be sufficient to prevent blockages, as the ratio of the periphery of the nozzle hole to its cross-sectional area decreases with increasing size. The ratio of the force of titanium sticking to the walls to the kinetic head of the TiCl_4 will therefore decrease with increasing feedhole diameter and hence the feedhole might be blown, and kept, open.

The procedure used by Seon and Nataf⁹ to form titanium powder by lithiothermic reduction of TiCl_4 in a molten salt reactor was to use a high-energy mixer. The mixer served to disperse undissolved lithium and gaseous TiCl_4 into the molten salt and possibly also to break up any lumps of



Figure 6—Dispersion by sonic nozzle

Titanium production via metallothermic reduction of $TiCl_4$ in molten salt



Figure 7—Blocked sonic nozzle

titanium that might form. This approach was not feasible in the reactor used in this study because the stirrer used was not mechanically stable enough to allow the high speeds required.

However, in order to prove that it is feasible to feed and produce titanium powder by metallothermic reduction in a molten salt, the stirrer available was adapted so that it would also mechanically clear the port through which the $TiCl_4$ was fed into the reactor. Mechanical clearing of blockages to the port allowed significant amounts of $TiCl_4$ to be continuously fed to the reactor, the reaction product of which is shown in Figure 8.

Products

The CSIR-Ti process aims at a single product in the form of CP (chemically pure) Grade 1 titanium metal powder that is suitable for making titanium components via powder metallurgical techniques. The chemical composition of the desired product must meet CP Grade 1 specifications, specifications of ASTM B299 for General Purpose Sponge and it must also contain less than 50 ppm chloride, as per Table I.

CSIR powders classified as titanium by X-ray diffraction (XRD) were further studied with scanning electron microscope (SEM) to visually obtain an idea of particle size and morphology. Chemical analyses were done by Mintek to establish the levels of residual chlorine (via gravimetric analyses), and nitrogen and oxygen (via LECO analyser) in the samples.

X-ray diffraction

XRD analysis of powder samples initially produced indicated impurities such as Cr, Ni and Fe. The only known source of

these elements was corrosion products from the materials of construction (MOC) of the reactor. More care was taken when leaching and cutting open the reactors to eliminate such contamination. As illustrated with the pie chart in Figure 9, it was later possible to collect product containing only some ferrotitanium (~1% FeTi) with the titanium metal. As expected for CP titanium powder, the crystal structure was found to be hexagonal, i.e. alpha titanium.

Product morphology

Powder product is normally found to settle to the bottom of the reactor and to consist of irregularly shaped, porous, friable solids of 1–5 mm diameter, illustrated in Figure 10. The solids break up easily when handled to produce a fine light grey powder which appears silver under strong light.

Powder produced by the CSIR-Ti process has recorded individual particle sizes from 1 to 330 μ m compared to the typical sizes for commercial titanium powders produced by gas atomization of less than 150 μ m and powders produced by the hydride-dehydride process of less than 45 μ m. Average particle sizes tend to fall in the range 15–20 μ m, but can be affected by the process conditions. For example Suzuki *et al.*, 1999⁵ illustrated the dependency of powder morphology and particle size on Ti^{2+} concentration, reduction temperature, time and concentration of salt when reducing $TiCl_4$ with magnesium in molten $MgCl_2$. Similarly, crystals with a particle size distribution preponderantly greater than about 20 mesh (833 μ m) had been produced by Keller and Zonis¹⁰ when slowly reducing titanium dichloride over a period of 5 hours with sodium in a molten salt bath at about 890°C.



Figure 8—Metallothermally produced titanium product

Table I

Target specification: maximum impurities (mass %)

Fe	Si	Ni	Cl	C	N	O
0.15	0.04	0.05	0.005	0.03	0.02	0.15

Titanium production via metallothermic reduction of TiCl_4 in molten salt

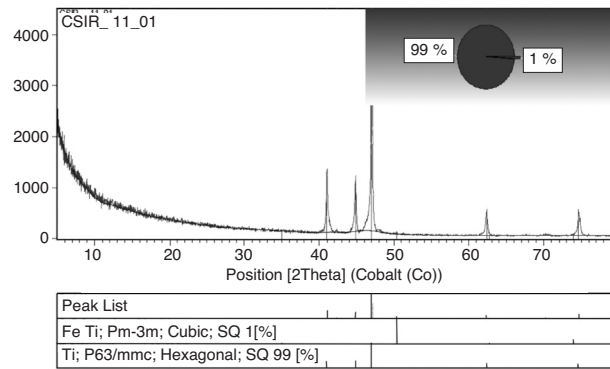

Figure 9—XRD of CSIR-Ti product



Figure 10—CSIR-Ti powder in frozen salt

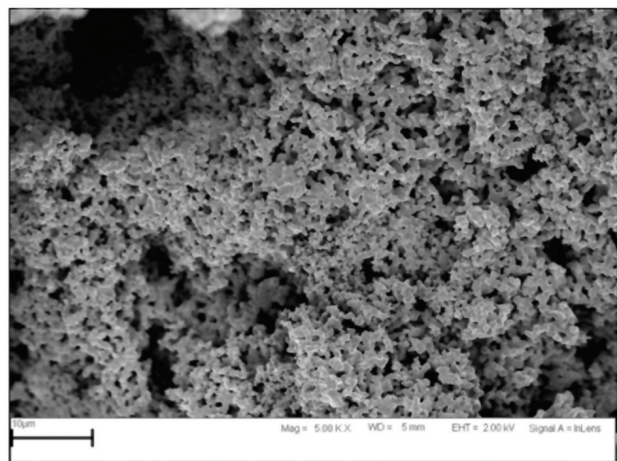

Figure 11. SEM of product (Scale = 10 μm)

Scanning electron microscopy (SEM) initially indicated small particle size ($<5 \mu\text{m}$), as illustrated in Figure 11. It is, however, possible to change crystal size and powder morphology; as can be seen in Figure 12, crystals in excess of $100 \mu\text{m}$ can be grown, and Figure 13 illustrates the effect of sintering at higher operating temperatures.

In the preceding illustrations are visible powder, acicular (needle-like) crystals, dendritic (branch-like) structures, plates and sintered lumps. The process conditions, e.g.

stirring intensity and reagent feed ratio, can be altered to favour the production of any one of these morphologies. The irregular shape of the powder has proven useful in compaction, where spherical powders have lower green strength.

Despite the irregular shape, the powder has also proven to possess acceptable flow characteristics to be continuously fed to a laser sintering process.

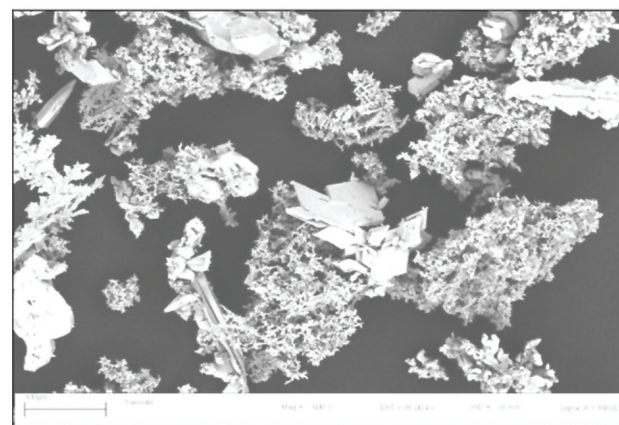

Figure 12—SEM photograph of product (scale = 100 μm)

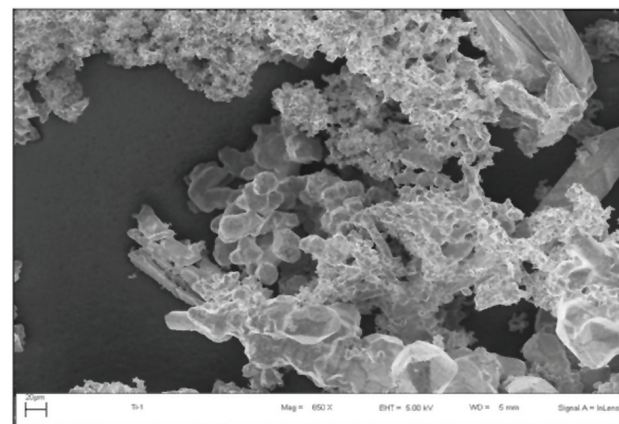

Figure 13—SEM of product (scale = 20 μm)

Titanium production via metallothermic reduction of TiCl₄ in molten salt

Chlorides

The levels of chlorides present in titanium powders vary depending on the method of production and leaching, e.g. where salt is leached with water rather than being vacuum distilled, the chloride content is generally lower, but oxygen content is normally higher. Residual chloride salt is undesirable since it can prevent the achievement of full density of powder-based titanium products and adversely affects weldability⁴. It has, for example, been found that when the chloride content is higher than 50 ppm, the chlorides volatilize rapidly during welding, causing a build-up of salt on tungsten welding electrodes, which results in an unstable arc¹¹.

Gravimetric analysis of total chloride in CSIR-Ti process powders by Mintek have consistently indicated chloride levels lower than the detection limit of 50 ppm of the analytical technique used. This is thought to be due to the open microstructure of the powders, as discussed in later sections.

Oxygen and nitrogen

Titanium is a reactive metal, capable of burning in both oxygen and nitrogen; however, under normal circumstances a passivating layer of titanium dioxide causes its well-known corrosion resistant properties.

Interstitial oxygen and nitrogen have a marked effect on titanium strength, with oxygen being the primary indicator for tensile properties of titanium metal and alloys. Due to the high solubility of these elements in titanium, surface oxygen at high temperature will diffuse into the metal, leading to embrittlement and hardening. Standards for titanium and its alloys are then mostly concerned with the levels of oxygen and nitrogen present in the material.

Initially CSIR-Ti powder contained oxygen in excess of commercial standards for powder titanium made via more expensive routes. CSIR-Ti powder analysed at Mintek, evidenced in Table II, an oxygen concentration of 0.88% vs. the target of 0.15–0.25%. The analyses was repeated and indicated an analytical variance of less than 0.04%, returning a result of 0.92% oxygen. Oxygen pick-up was expected as reactor sealing and presence of an inert atmosphere over the reactor could not be maintained during semi-continuous operations. Furthermore, the very small particle sizes initially achieved had an unfavourable surface to volume ratio, leading to a high amount of surface oxygen to overall particle mass. Lastly, optimization of materials handling operations such as product leaching and drying had also not been investigated yet.

Nitrogen levels were within acceptable limits, being at the detection limit of 50 ppm vs. an allowed maximum of 200 ppm.

Recent analyses indicated decreasing oxygen levels (Table III), as experienced has been gained to improve the experimental procedures. As the scale of experiments have increased, the quality of product produced in a single experiment have been found to vary depending on where in the reactor it was retrieved, e.g. product found at the top of the reactor, which was not fully covered by molten salt and which was the first to be contaminated by air ingress, was higher in oxygen (0.58%) than the product recovered from the bottom of the reactor. Most recently, oxygen levels of

0.19% have been achieved, which is within range for titanium powder metallurgy (0.15–0.25%). A present focus of the work is on reducing oxygen pick-up during water leaching and product drying, which is expected to further reduce oxygen contamination.

Conclusions and recommendations

- ▶ A process for the continuous production of titanium powder by metallothermic reduction of TiCl₄ in molten salt is technically feasible.
- ▶ The product quality, specifically in terms of low residual chloride content, is very promising.
- ▶ At an average particle size of 15–20 μm, CSIR-Ti powder lends itself to powder metallurgical processes, and has been proven effective as a feedstock in laser sintering.
- ▶ The process is believed to have significant commercial potential for the production of lower-cost titanium especially for use in powder metallurgy applications to produce near-net shape products.

Process concerns and recommended areas of future research are the:

- ▶ Development of an efficacious method to prevent blockages of the TiCl₄ feed line and the formation of Ti powder lumps
- ▶ Consistent achievement of the chemical specifications of the desired product (< 50 ppm Cl and ≈0.15% O)
- ▶ Suitability of powders for downstream powder metallurgical applications
- ▶ Safety in operation which utilize molten salt, TiCl₄ and molten alkali or alkali earth metals.

Acknowledgement

Without the support of the Department of Science and Technology (DST), the work reported above would not have been done. The leading role of the DST to ultimately facilitate and support the establishment of a titanium metal industry in South Africa is greatly appreciated.

Table II

Chemical analyses of initial product

Sample name	Chloride ppm	O %	N ppm
CSTR1	<50	0.88	<50
CSTR1 (repeat)	<50	0.92	<50

Table III

Oxygen concentration of recent products

Description	O %
CSTR top	0.58
CSTR bottom	0.5
Screened: +50 -100 μm	0.19

Titanium production via metallothermic reduction of $TiCl_4$ in molten salt

References

1. VAN VUUREN, D.S. A Critical Evaluation of Processes to Produce Primary Titanium, *Journal of The Southern African Institute of Mining and Metallurgy*, vol. 109, August 2009, pp. 455–461.
2. TZ MINERALS INTERNATIONAL AND EHK TECHNOLOGIES. Ti-Metal: The Global Titanium Metal Industry, 2007, p. 171.
3. EHK TECHNOLOGIES. Summary of emerging titanium cost reduction technologies, A study for US Department of Energy and Oak Ridge National Laboratory, Subcontract 4000023694. 2003.
4. FROES, F.H. Developments in titanium P/M, University of Idaho, www.webs1.uidaho.edu/imap/MPR%20Paper.pdf#search=%22%22Developments%20in%20Titanium%20P%2FM%22%22. 1 September 2006.
5. SUZUKI, R.O., HARADA, T.N., MATSUNAGA, T., DEURA, T.N., and ONO, K. Titanium Powder Prepared by Magnesiothermic Reduction of Ti^{2+} in Molten Salt, *Metallurgical and Materials Transactions*, vol. 30B, June 1999, p. 403.
6. WINTER, C.H. Production of Metals, US Patent 2,607,674, 19 Aug. 1952.
7. WHITE, J.C. and ODEN, L.L. Continuous Production of Granular Ti, Zr and Hf or Their Alloy Products, US Patent 5,259,862, 9 Nov. 1993.
8. ARMSTRONG, D.R., BORYS, S.R., and ANDERSON, R.P. Titanium and Titanium Alloy, US Patent 7,445,658, 4 Nov. 2008.
9. SEON, F. and NATAF, P. Production of Metals by Metallothermia, US Patent 4,725,312, 16 Feb. 1988.
10. KELLER, W.H and ZONIS, I.S. Method of Producing Titanium, US Patent 2,846,303, 5 August 1958.
11. FINLAY, W.L. (Chairman) Titanium: Past, Present and Future, Publication NMAB-392, National Academy Press, Washington D.C., p. 208 http://www.nap.edu/openbook.php?record_id=1712&page=R1 [7 January 2010]. 1993. ◆

Talk to TURGIS Minerals Industry Professionals



VACANCIES: MINING AND MECHANICAL ENGINEERS

Turgis Consulting has vacancies for both Senior and Junior Mining and Mechanical Engineers with significant experience in mining and/or Head office/ Consulting environment.

Send a CV with contact details to: turgis@turgis.co.za
Close at Midday 15 April 2011.

Turgis – integrated mining solutions for an environmentally demanding world.



Tel: +27 11 476 2279 Email: turgis@turgis.co.za

Web sites: www.turgis.co.za www.turgisconsulting.co.uk www.dhv.com