

Structure Selective mRNA Recognition for HIV-1 RRE: New routes towards synthesis of 2-deoxystreptamine analogue -the central scaffold of Aminoglycosides.

A dissertation submitted to The University of Manchester for the degree of Master of Science by Research in the Faculty of Engineering and Physical Sciences

2012

MANJUSHA ROY CHOUDHURY

School of Chemistry

TABLE OF CONTENTS

LIST OF TABLES	4
LIST OF FIGURES	5
LIST OF SCHEMES.....	6
ABSTRACT.....	7
DECLARATION	8
COPYRIGHT STATEMENT	9
ACKNOWLEDGEMENT	10
LIST OF ABBREVIATIONS.....	11
CHAPTER 1. Introduction.....	14
1.1. Nucleic Acids.....	14
1.2. General Structure of Nucleic Acids	14
1.3. Structure of RNA	15
1.4. Secondary Structure.....	17
1.4.1. RNA Double Helices	17
1.4.2. RNA Non Watson-Crick Base Pairs	18
1.4.3. Hairpin or Stem Loops.....	19
1.4.4. Internal Loops and Bulges	19
1.5. RNA Tertiary Structure.....	20
1.5.1. RNA Helical Stacking.....	20
1.5.2. RNA Junctions	22
1.5.3. Cationic Metals	22
1.5.4. A-minor motif.....	23
1.5.5. Ribose Zipper.....	23
1.6. RNA Quaternary Structure.....	23
1.7. HIV-1 Rev Response Element and Life Cycle of HIV	24
1.8. Secondary Structure and Rev Binding.....	25
1.9. RRE as a scaffold for Rev Assembly and Function.....	26
1.10. 2-Deoxystreptamine aminoglycoside inhibition of HIV RRE/Rev binding	27
1.11. Biosynthesis from D-glucose -6-phosphate	30
1.12. Degradation of Neomycin.....	31
1.13. De novo Synthesis: Delft's efficient synthesis of 2-DOS	32
1.14. Synthesis from the Chiral Pool	34
1.14.1. Synthesis from neamine	34
1.14.2. Synthesis of enantiopure protected 2-DOS from D-allylglycine	35

1.14.3.	Synthesis of orthogonally protected 2-DOS from α -glucopyranoside	36
1.15.	Asymmetrization of meso 2-deoxystreptamine	37
1.15.1.	Orsat Resolution.....	37
1.15.2.	Prinzbach Resolution	38
1.15.3.	Wong Enzymatic Resolution	38
1.15.4.	Wong Chemical Resolution	39
1.16.	Synthesis of analogue of 2-deoxystreptamine - 2,5-dideoxystreptamine.....	40
1.16.1.	Synthesis of meso-2,5-dideoxystreptamine	40
1.16.2.	Desymmetrisation of the obtained 2,5-dideoxystreptamine.....	42
1.17.	Other routes to synthesis of 2,5-dideoxystreptamine	43
1.17.1.	Alternate Route to 2,5-dideoxystreptamine	43
1.17.2.	Desymmetrisation for the formation of 2,5-dideoxystreptamine	44
1.18.	Project Aim	45
CHAPTER 2. RESULTS AND DISCUSSIONS.....		47
2.1.	2,5-dideoxystreptamine.....	47
2.2.	Literature Synthesis of 2,5-dideoxystreptamine	47
2.3.	Novel Route to 2, 5-dideoxystreptamine – General Strategy A.....	51
2.3.1.	Synthesis of Nitroalkenes.....	52
2.3.2.	Cross Metathesis of nitro compounds	55
2.3.3.	Intramolecular Henry Reaction.....	57
2.4.	General Strategy B.....	58
2.4.1.	Nitro compound synthesised for Strategy B	58
2.4.2.	Intermolecular Henry Reaction.....	62
2.4.3.	Ring Closing Metathesis	64
2.5.	General Strategy C.....	65
2.5.1.	Tin (II) chloride mediated nitroalcohol formation	66
2.5.2.	Seebach's conditions for deprotonation followed by reaction with benzyl bromide... ..	68
2.5.3.	Ring Closing Metathesis	68
2.6.	Attempted Dehydration of 4-nitro-1-phenylbutene and (E)-2-nitro-1, 5-diphenylpent-4-en-1-ol	69
2.7.	Conclusion and Future works	70
CHAPETR 3. EXPERIMENTAL.....		73
3.1.	General	73
3.2.	Synthesis of 2, 5-dideoxystreptamine using Bisepoxide method.....	73
3.2.1.	1, 4-Diepoxy cyclohexane by Direct Bisepoxidation.....	73

3.2.2.	<i>Trans</i> -4-Hydroxy-5-bromocyclohexene	75
3.2.3.	4, 5 Epoxy- <i>trans</i> -2-bromocyclohexanol	75
3.2.4.	1, 4-Diepoxy-cyclohexane.....	76
3.2.5.	1, 4-cyclohexadiene monoepoxide.....	76
3.2.6.	7, 8-Diazabicyclo [3.2.1] octane-4, 6-diol	77
3.3.	Novel Synthesis of 2,5-dideoxystreptamine from nitro compounds –.....	77
3.3.1.	4-nitrobutene	77
3.3.2.	6-nitrohexa-1, 3-diene.....	78
3.4.	Strategy B.....	79
3.4.1(a).	Cinnamyl Ethyl Carbonate.....	79
3.4.1(b).	4-Nitro-1-phenylbutene.....	80
3.4.2(a).	2-nitro-1-phenylpent-4-en-1-ol	81
3.4.2(b).	(<i>E</i>)-2-nitro-1, 5-diphenylpent-4-en-1-ol-Diastereomer A and B.....	81
3.5.	Strategy C.....	82
3.5.1(a).	1-nitropent-3-en-2-ol.....	82
3.5.1(b).	1-phenyl-but-2-en-1-ol.....	83
3.5.1(c).	(3-nitropropyl) benzene.....	84
3.5.2.	2-nitro-1-phenylhex-4-en-3-ol	84
3.6.	Dehydration.....	85
3.6.1.	(<i>1E</i> , <i>3E</i>)-1-nitropenta-1, 3-diene, (<i>1E</i> , <i>3Z</i>)-1-nitropenta-1,3-diene	85
3.6.2.	(<i>1Z</i> , <i>4E</i>)-2-nitro-1,5-diphenylpenta-1,4-dien-1-ol, (<i>1E</i> , <i>4E</i>)-2-nitro-1,5-diphenylpenta-1,4-dien-1-ol.....	85
	REFERENCES	87

LIST OF TABLES

Table 1 Comparison of chemical shifts and J values of the two diastereomers of (E)-2-nitro-1,5-diphenylpent-4-en-1-ol	64
---	----

LIST OF FIGURES

Figure 1 Nucleotides of DNA and RNA.....	14
Figure 2 Bases of nucleic acids.....	15
Figure 3 Hierarchy of folding in RNA (a) Primary Structure (b) Secondary Structure (in this case two stem-loops) showing Watson-Crick base pairing between complementary nucleotides (c) Tertiary Structure (Coaxial stacking giving rise to three dimensional structure).....	16
Figure 4 RNA secondary structures.....	18
Figure 5 Examples of RNA tertiary structure. RNA backbones are highlighted in red and yellow in the kissing loop and in orange in pseudoknot and 3-way junction. Magnesium ions that are significant for stabilisation and functioning of 3 way junctions are highlighted with magenta spheres. Hydrogen bonds in A-minor motif and Ribose Zipper are highlighted as dotted line..	21
Figure 6 Organisation of HIV genome. RRE lies in the between 7709-8063 nucleotide region.	24
Figure 7 In the early stages of viral life cycle all transcripts are completely spliced and exported in a Rev/RRE independent pathway. A subset of these transcripts code Rev which is then imported to the nucleus. In the later phase, intronic RNA containing RRE then use Rev and nuclear export machinery for transport to avoid splicing and reach cytoplasm where they are translated and packaged as new virion.....	25
Figure 8 Secondary Structure of functional region of RRE (sequence obtained from HXB3 strain) with labelled major stem loop. Stem II B is high affinity site necessary for Rev binding. Stem IA is recently identified secondary RNA binding site for Rev.....	26
Figure 9 Examples of 2-deoxystreptamine aminoglycosides.....	29
Figure 10 2,5-dideoxystreptamine 5	46
Figure 11 Intermediate formation in epoxidation of bromohydrin 59a (Mechanism).	49
Figure 12 Nucleophilic ring opening of the cis epoxide 60a	51
Figure 13 Mechanism of cross metathesis	56
Figure 14 Grubbs II generation catalyst.....	57
Figure 15 Nitromethylation mechanism via palladium-induced ionisation-fragmentation sequence.....	60
Figure 16 (Z)-olefins yields anti configuration complex while (E)-olefins give rise to stable syn isomer.....	61

LIST OF SCHEMES

Scheme 1 Biosynthesis of 2-deoxystreptamine.	30
Scheme 2 Degradation of Neomycin method 1.	31
Scheme 3 Degradation of Neomycin method 2.	32
Scheme 4 Efficient chemical synthesis of 2-DOS proposed by Delft group	33
Scheme 5 Synthesis of enantiopure 2-DOS from neomycin.....	34
Scheme 6 Synthesis of enantiopure protected 2-DOS from D-allylglycine.....	36
Scheme 7 Synthesis of orthogonally protected 2-DOS from α -glucopyranoside.	37
Scheme 8 Orsat Resolution.....	38
Scheme 9 Prinzbach Resolution.....	38
Scheme 10 Wong Enzymatic Resolution.....	39
Scheme 11 Wong Chemical Resolution.....	39
Scheme 12 Synthesis of 2,5-dideoxystreptamine.....	40
Scheme 13 Mechanism of reaction of hydrazine with bisepoxides.	41
Scheme 14 Desymmetrization of 2,5-dideoxystreptamine	42
Scheme 15 Second Route to Synthesis of 2,5-dideoxystreptamine	44
Scheme 16 Desymmetrisation of 2,5-dideoxystreptamine analogues.....	45
Scheme 17 Synthesis of 2,5-DDOS	48
Scheme 18 Synthetic routes to the bisepoxidation of 1,4-cyclohexadiene	49
Scheme 19 Synthetic routes to mono and bisepoxides using mCPBA and K ₂ HPO ₄	50
Scheme 20 General Strategy A	52
Scheme 21 Reaction of 4-bromobutene with AgNO ₂	52
Scheme 22 Reaction of 4-bromobutene with NaNO ₂	54
Scheme 23 Attempted cross metathesis with Grubbs II catalyst	55
Scheme 24 Possible Future attempts at Intramolecular Nitroaldol of (E)-5-nitropent-2-enal	57
Scheme 25 General Strategy B	58
Scheme 26 Synthesis of 4-nitro-1-phenylbutene using Pd catalyst route.	59
Scheme 27 Attempted intermolecular Henry reaction under KOH, solventless conditions	62
Scheme 28 Intermolecular Henry Reaction with triethylamine base and water.	63
Scheme 29 Future attempts at ring closing metathesis of 5-nitroocta-1, 7-dien-4-ol	64
Scheme 30 Future attempts at ring closing metathesis of (E)-5-nitro-8-phenylocta-1, 7-dien-4-ol.	65
Scheme 31 General Strategy C	66
Scheme 32 Synthesis of (E)-1-nitropent-3-en-2-ol using tin(II) chloride reaction	66
Scheme 33 Reformatsky-type mechanism for preparation of 1-nitropent-3-en-2-ol.....	67
Scheme 34 Attempted tin (II) chloride reaction between crotonaldehyde and benzyl bromide, benzyl bromide and bromonitromethane.	67
Scheme 35 Attempted deprotonation using Seebach's technique.	68
Scheme 36 Future attempts at ring closing metathesis of 97.....	68
Scheme 37 Attempted dehydration of 1-nitropent-3-en-2-ol.....	69
Scheme 38 Attempted dehydration of (E)-2-nitro-1,5-diphenylpent-4-en-1-ol.....	70
Scheme 39 Strategy A.....	71
Scheme 40 Strategy B.....	71
Scheme 41 Strategy C.....	72

ABSTRACT

Most of the drugs till date aim to bind proteins which are difficult macromolecular targets. RNA finds various roles within organisms including storage of genetic information as in case of hepatitis virus, messenger and transfer RNA are involved in protein synthesis, while snRNA is responsible for splicing. Hence, there are a number of RNAs that are biologically viable therapeutic drug targets and in our project we are particularly interested in the mRNA of HIV-retrovirus. Many cellular processes are regulated by the specific interaction of a protein α -helix with a specific region of the DNA or RNA. Neomycin, an aminoglycoside antibiotic, shows micro-molar binding to the Rev Response Element (RRE) of HIV-1 mRNA.

2-deoxystreptamine, the Ring B of neamine is a common scaffold for many aminoglycosides. This work describes the synthesis of 2,5-dideoxystreptamine, a molecule of intermediate complexity that retains four of the heteroatom substituents and preserves the stereochemistry of 2-DOS. The traditional bisepoxide route to the molecule has been performed via bis-epoxidation, followed by ring opening of the *cis* epoxide with hydrazine and subsequent reductive cleavage, in order to understand the loopholes of the method. New routes towards this central scaffold were sought due to the low yielding epoxidation step involved in the synthetic route discussed above. This piece of work brings forth three novel strategies towards the synthesis of the 2,5-dideoxystreptamine analogues from nitro based compounds. Strategy A starts with cross metathesis between nitro-olefins and alkenals followed by intramolecular nitroaldol to give cyclic nitroalcohol containing a double bond that can suitably be substituted to append a library of 2, 5-dideoxystreptamine analogues

Strategies B and C are based on reaction of various nitro alkenes synthesized in the lab to yield nitroalcohols either via Henry's Nitroaldol Reaction or tin (II) chloride mediated reaction with bromonitromethane. These nitroalcohols are subsequently alkylated by alkenes followed by ring closing metathesis to yield 2,5-dideoxystreptamine analogues. Ground research for these new techniques have been performed in this thesis and improvement in the various reaction conditions and procedures of these strategies may provide high yielding routes to the synthesis of these 2,5- dideoxystreptamine analogues.

DECLARATION

No portion of the work referred to in the dissertation has been submitted in support of an application for another degree or qualification of this or any other university or other institute of learning.

COPYRIGHT STATEMENT

- i.** The author of this dissertation (including any appendices and/or schedules to this dissertation) owns any copyright in it (the “Copyright”) and she has given The University of Manchester the right to use such Copyright for any administrative, promotional, educational and/or teaching purposes.
- ii.** Copies of this dissertation, either in full or in extracts, may be made only in accordance with the regulations of the John Rylands University Library of Manchester. Details of these regulations may be obtained from the Librarian. This page must form part of any such copies made.
- iii.** The ownership of any patents, designs, trade marks and any and all other intellectual property rights except for the Copyright (the “Intellectual Property Rights”) and any reproductions of copyright works, for example graphs and tables (“Reproductions”), which may be described in this dissertation, may not be owned by the author and may be owned by third parties. Such Intellectual Property Rights and Reproductions cannot and must not be made available for use without the prior written permission of the owner(s) of the relevant Intellectual Property Rights and/or Reproductions.
- iv.** Further information on the conditions under which disclosure, publication and exploitation of this dissertation, the Copyright and any Intellectual Property Rights and/or Reproductions described in it may take place is available from the Head of School of Chemistry.

ACKNOWLEDGEMENT

I am deeply grateful to the Lord Almighty for giving me the strength to persevere when things got tough. I would like to thank Dr. David Berrisford for his able guidance and constant support during my research. This dissertation in its current form would not have been possible without the perseverant efforts of Dr. Berrisford to help make my research successful.

I would also like to thank the entire research group who made working in the lab a lot of fun. A special thanks to Binto Simon who gave valuable inputs in my work. I would also like to thank the School of Chemistry, the faculty, the support staff for facilitating my study and research at The University of Manchester.

Last but not the least I would like to thank my parents and my sister for always supporting me in my endeavours.

LIST OF ABBREVIATIONS

A	Adenine
ARM	arginine rich motif
AcPh	Phenylacetyl
Ar	Aromatic
Arg	Arginine
Bn	Benzyl
Boc	t-Butyloxycarbonyl
br	Broad
C	Cytosine
calc	Calculated
COSY	Correlated spectroscopy
CRL	<i>Candida rugosa lipase</i>
°C	Degree centigrade
d	Doublet
dd	double doublet
DBA	Dibenzylideneacetone
DCM	Dichloromethane
DMAP	Dimethylamino pyridine
DMF	Dimethylformamide
DMSO	dimethyl sulfoxide
DNA	deoxyribonucleic acid
DOI	2-deoxy-scylo-inosose
DOIA	deoxy-scylo-inosamine
DOIS	deoxy-scylo-inosose synthase
2-DOS	2-deoxystreptamine
2,5-DDOS	2,5-dideoxystreptamine
dt	doublet of triplets
dppf	[1,1'-Bis(diphenylphosphino)ferrocene]
ee	enantiomeric excess
equiv.	Equivalent
ESI	electrospray ionisation

ESI-MS	electrospray ionisation mass spectrometry
EtOH	Ethanol
G	Guanine
H _{ax}	axial proton
H _{eq}	equatorial proton
HCV	Hepatitis C virus
HIV	Human immunodeficiency virus type-1
hr	Hour
Hz	Hertz
IR	Infra red
kb	Kilobase
lit.	Literature
mCPBA	meta-chloroperbenzoic acid
MOM	methoxy methyl
mRNA	messenger ribonucleic acid
m/z	mass/charge
MeOH	Methanol
μM	Micromolar
mg	Milligram
MHz	Megahertz
ml	Millilitre
MS	molecular sieves
NAD ⁺	Nicotinamide adenine dinucleotide
NBS	<i>N</i> -bromosuccinimide
NMR	Nuclear magnetic resonance
p-	Para
Ph	Phenyl
PMB	p-methoxybenyl
ppm	parts per million
pre-mRNA	pre- messenger ribonucleic acid
pyr	Pyridine
RCM	ring closing metathesis
rRNA	ribosomal ribonucleic acid

RNA	ribonucleic acid
RRE	rev response element
rt	room temperature
s	Singlet
snRNP	small nuclear ribonucleoproteins
t	Triplet
^t Bu	Tert-butyl
tRNA	transfer ribonucleic acid
T	Thymine
TBAH	Tertabutylammonium hydroxide
TEA	Triethylamine
TLC	Thin Layer Chromatography
TMS	Trimethyl silyl
TFA	Trifluoroacetic acid
U	Uracil
UV	Ultra violet
W	Watt
v:v	volume:volume
w	weak intensity
w:v	weight:volume

CHAPTER 1. Introduction

1.1. Nucleic Acids

Nucleic Acids are long chain biological polymers having a high molecular mass and are responsible for the development of all forms of life. These are also referred to as polynucleotides as they are formed by the polymerisation reaction of the repeating monomer unit called nucleotide. There are mainly two types of nucleic acids namely deoxyribonucleic acid (DNA) and ribonucleic acid (RNA), each made up of a repeating monomer unit connected by covalent bonding.^{1,2} Nucleic acids play a major role in the synthesis of proteins and as a repository and transmitter of genetic information for all organisms.¹ The structures of the monomer units of DNA and RNA are illustrated in Figure 1.

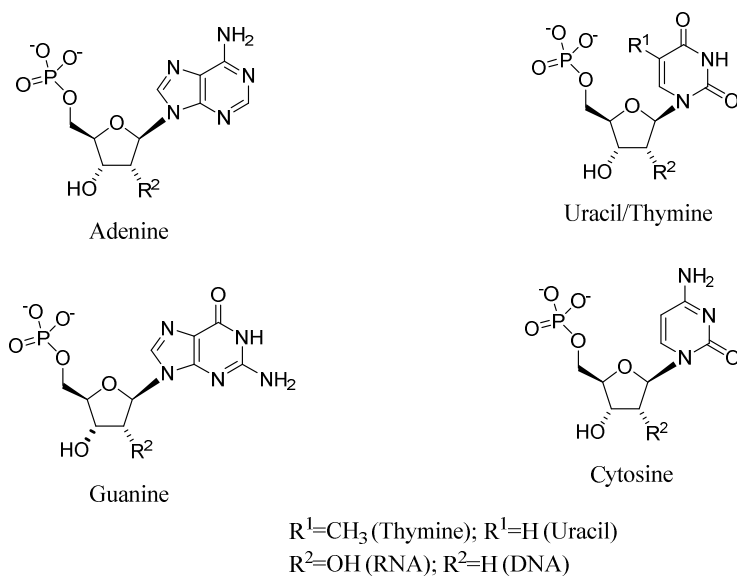

Figure 1 Nucleotides of DNA and RNA (Refer to section 1.2 for definition of nucleotide).

1.2. General Structure of Nucleic Acids

Nucleic acids are polymers consisting of a basic monomeric unit of a five carbon sugar, ribose, in RNA and 2' deoxyribose in DNA i.e. the hydroxyl group in RNA at 2' position is replaced by a hydrogen in DNA (The numbering of the sugar carbons are done using primes to differentiate from the numbering of the base carbons). The various monomeric units are linked to each other through **phosphodiester** linkage formed between the phosphate group attached to the hydroxyl on the 5' carbon of one unit to

the hydroxyl group on the 3' carbon of the next unit. This polymeric structure forms the basic backbone of nucleic acids.

The polymeric repetitious structure on its own is incapable of storing and transmitting data. Nucleic acids' ability to encode data comes from their heteropolymeric nature due to the presence of heterocyclic bases attached to the 1' carbon on the sugar. There are two types of bases namely **purines** and **pyrimidines**. DNA comprises of two purines- **adenine (A)** and **guanine (G)** and two pyrimidines- **cytosine(C)** and **thymine (T)**. RNA comprises the same set of bases except for **Uracil (U)** which replaces thymine in DNA (Figure 2). In the case of purines, the attachment is at nitrogen 9 while in the case of pyrimidines it takes place at nitrogen 1. The bond between the 1' carbon of the sugar residue and the nitrogen from the base is known as a **glycosidic bond** and these monomers consisting of the sugar and the base residues are termed as **nucleotides**.³

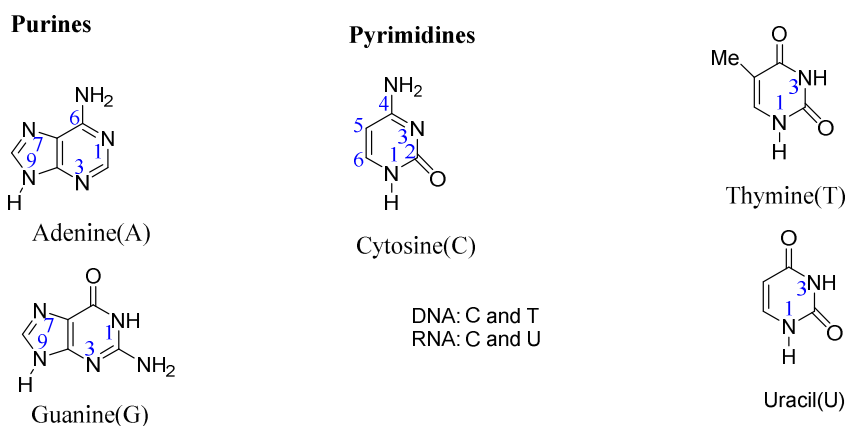

Figure 2 Bases of nucleic acids.

1.3. Structure of RNA

RNA structure, just like proteins, can be divided into primary, secondary, tertiary and quaternary structure (Figure 3). This classification becomes even more apt for RNA than for proteins due to the separation of the thermodynamics of interaction between secondary and tertiary RNA that leads to the stability of the various RNA conformations. The secondary and tertiary RNA structures are also considered to be experimentally separated by the requirement of divalent or small molecule bindings for stability by tertiary structure which is not required for secondary structure formation.⁴

The **Primary Structure** of RNA highlights the sequence of the RNA molecule.⁵ Unlike proteins, where proper folding is essential for their functioning, RNA can function even

as single strands. mRNA, for instance, must be unfolded in order for genetic message to be translated and stable secondary structure in this case can lead to pausing or frame shifting and ultimately hinder protein expression.⁶

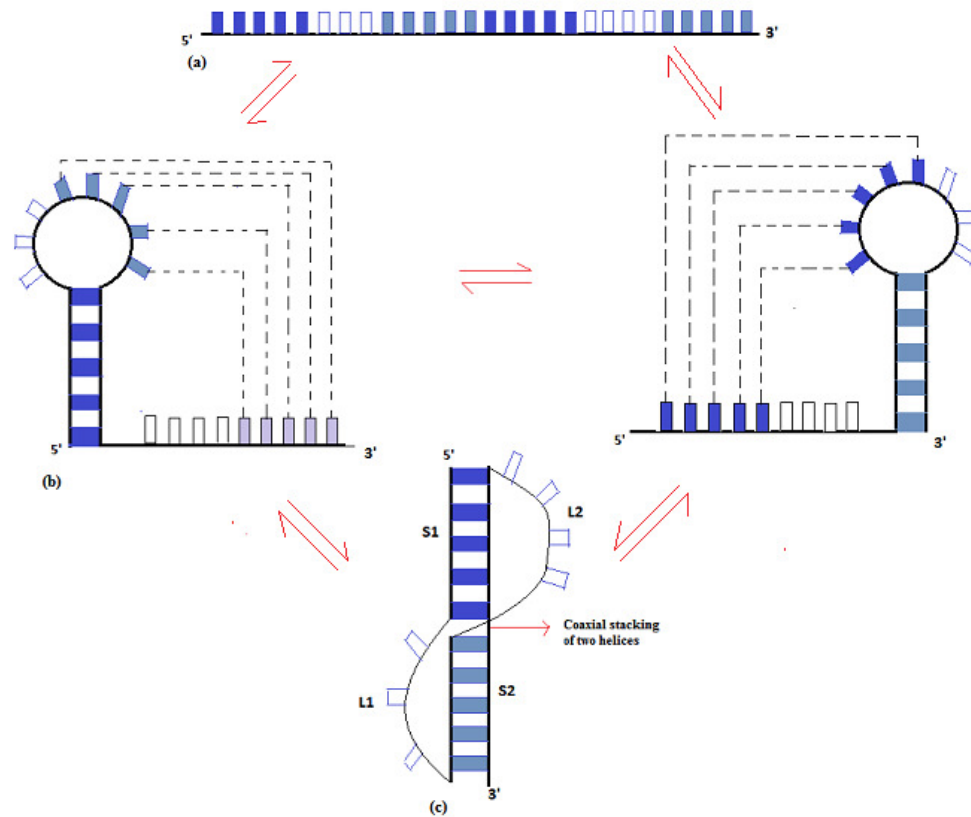

Figure 3 Hierarchy of folding in RNA (a) Primary Structure (b) Secondary Structure (in this case two stem-loops) showing Watson-Crick base pairing between complementary nucleotides (c) Tertiary Structure (Coaxial stacking giving rise to three dimensional structure).

The **Secondary Structure** refers to the Watson–Crick base pairing that takes place to form an anti-parallel double helical structure of different lengths.⁷ Biologically it is uncommon to find RNA strands having more than 10-12 base pairs not interrupted by single-stranded nucleotides. Isolated base pairs do not possess thermodynamic stability but the pairing of consecutive bases occurs with ease leading to various possible RNA structures. These secondary double helical tracts form the foundation for the construction of complex three dimensional **tertiary structures**. These complex three dimensional structures can be constructed by arrangement of helical tracts through tertiary contacts and their interaction with metal ions and other small molecule binding.⁷

tRNA still remains one of the best examples to understand the hierarchical chassis of RNA. Secondary tRNA structure comprises of four A-form double helical segments dominated by Watson-Crick base pairing- the acceptor, anticodon, D and T arms. These form three dimensional L-structures by the meeting of two coaxial helical stacks at a right angle. One of the stacks is formed by the acceptor and the T stem while the second helical stack is formed by D and anticodon arms. There are interactions between the T and D loops and nucleotides at the junction. The tertiary interactions include non Watson-Crick interactions between base pairs, binding to the magnesium ion in the non helical region and the interactions between the bases and the phosphate backbone. The ends of the long helical stacks bear the anticodon loop and acceptor end that are the functional regions of the tRNA molecules. The secondary structure forms the basis of active L-shaped tertiary tRNA which contains functional regions for protein synthesis machinery.⁸

1.4. Secondary Structure

As discussed earlier, secondary RNA (Figure 4) structure involves Watson-Crick base pairing in double helices and interruptions of these helices by single nucleotides to form various loop elements: hairpins, bulges and internal loops that cause disruptions in the secondary double helical structure of RNA. In the case of viral RNAs it is seen that the most stabilised double helices correspond to the regions having high biological importance.⁷

1.4.1. RNA Double Helices

RNA has an anti-parallel right handed double helix system. Due to the presence of the 2' OH group, RNA helices prefer to adopt A- form having a very deep and narrow major groove and a shallow and wide minor groove unlike the B-form adopted by DNA. As a result of the variation in conformation leading to different shapes, there is a significant impact on the binding property of the two with proteins and other ligands. More than 50% of nucleotides in RNA that are in sequence are included in the double helices. Though RNA double helical structure is not uniform but it still shows less inconsistency than DNA.⁷

1.4.2. RNA Non Watson-Crick Base Pairs

These are mismatches in the base pairs in the double helices of RNA which occur by accident but are an important part of RNA structure and frequently surpass the essential functions. There are various types of mismatches common in RNA: G × U wobble pairs, G × A sheared, A × U reverse Hoogsteen and G × A imino base pairs. G × U wobble pairs are almost as common in RNA as G × C and A × U base pairs and possess similar stability.

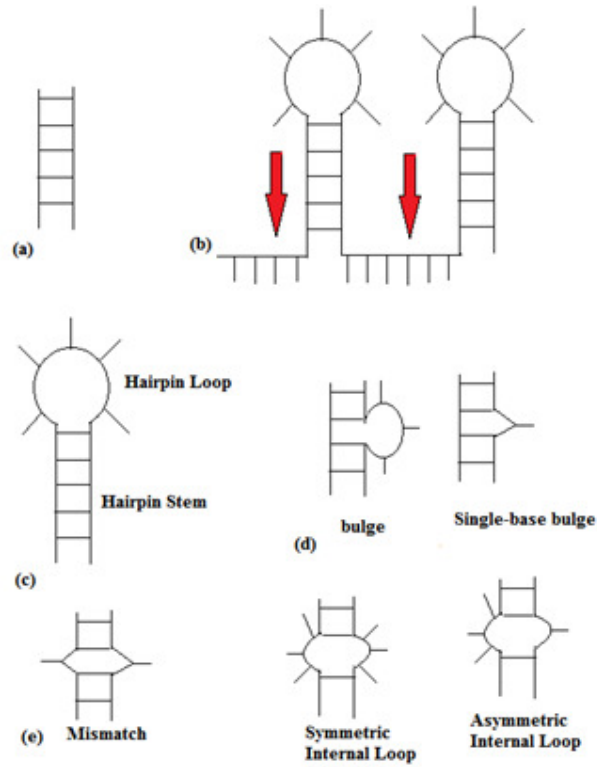

Figure 4 RNA secondary structures.

G × A sheared are common at the ends of double helices. These non-canonical base pairs often have similar stability as Watson-Crick base pairs but are responsible for bringing up distortions in the structure. In the case of G × U wobble pairs, although there is minimum distortion and it fits into the A-form helix smoothly, it brings about changes that are sufficient for recognition of RNA by proteins and other ligands.⁹

1.4.3. Hairpin or Stem Loops

Hairpins are formed by the folding of the phosphodiester backbone back on itself to form a double helical tract having unpaired nucleotides that form a single stranded region referred to as the loop. Hairpin loop is an extensively studied structural feature after the double helices. Small hairpin loops are more structured while long ones having 7-8 unpaired bases are more flexible and thermodynamically less stable. Hairpin loops in ribosomal RNA are mostly 4-9 nucleotides long. The most common hairpins containing four nucleotides mostly prevalent in cellular RNA belong to one of these three sequence families: UNCG, GNRA and CUUG (where N stands for any nucleotide and R is any purine base). Thermodynamic stability of a double helical tract capped with a tetraloop is similar to that of the same tract extended by two base pairs. Although there is a difference in the sequence of the nucleotides in these three families, they resemble each other in their structure. The first and the last unpaired nucleotides of the tetraloop form a non Watson-Crick base pair thereby leaving behind only two unpaired bases. Long hairpins, as is common in tRNA, involve a number of base stacking interactions that stabilise the loop but in turn make it very flexible conformationally.^{7, 10}

1.4.4. Internal Loops and Bulges

A **Bulge** is formed when two double helical tracts are separated on one bulge while **internal loops** are formed when both the strands are separated by one or more nucleotides. Internal loops having equal number of bases in both strands are symmetric and the loops with different number of bases in the two strands are asymmetric. A Single mismatch can be thought of as a symmetric loop or bulge containing two nucleotides. Though internal loops and bulges have lower thermal stability than double helix tracts but these unpaired bases are more accessible by proteins and other ligands. The unpaired nucleotides inside internal loops can undergo non Watson-Crick base pairing whereas the unpaired nucleotides in bulges can stack together or bulge outside. Internal loops and bulges cause bending in RNA molecule and the amount of bending depends on the RNA sequence in the loops and bulges which stimulates ligand binding.^{4, 7, 11} The kink turn motifs, common in small and large ribosomal RNAs, is an asymmetric internal loop in duplex RNA that leads to a tight kink in the helical system. This K- turn is a three nucleotide bulge with G × C base pairs on one side and 2-3 sheared G × A non canonical base pairs on the other side. This K-turn is stabilised by

A- minor tertiary interactions within the helical arms. These internal loops and bulges thus can act as switches and ligand binding can hence lead to conformational changes.^{12, 13}

E-loops, first observed in ribosomal RNA, are common internal loop sequences which have a different structural inclination. Most of the E-loops are asymmetric internal loops with AGUA nucleotides on one side and RAM nucleotides on the other, where R stands for G or A and M stands for C or A. The 5' end generally contains at least two base pairs while the 3' end has one base pair. The nucleotides show different cross strand interactions such as a sheared A × G, *trans* Hoogsteen U × A, parallel A × A and a bulge G. Thus, RNA secondary structure can basically be considered as double helical tracts interrupted by single stranded nucleotides.^{14, 15, 16}

1.5. RNA Tertiary Structure

RNA tertiary structure (Figure 5) is formed by the interaction of two or more secondary structures. More or less all complex RNAs are derived from simple tertiary structure units that act as the building blocks. Tertiary interactions consist of non Watson-Crick base pairing, base stacking interactions, triple stranded interactions such as base triples, metal ion interactions and interaction between unpaired bases and the phosphodiester backbone and riboses. The three dimensional structures of many RNAs, including small RNAs such as tRNAs, riboswitches and more complex RNAs like ribosomal RNAs, have been studied at atomic level and are best example of RNA folding of secondary structures to yield more complex tertiary interactions.^{9, 11}

1.5.1. RNA Helical Stacking

Helical stacking is the coaxial arrangement of two helices such that terminal base pairs interact to give a super helix at the junction. These helical stacking interactions have high energy and form the basis of the tertiary structure. There are different types of helical stacking known namely **adenosine platforms**, **kissing-loops** and **pseudoknots**. Two consecutive adenosine bases of an internal loop may interact to form a pseudo- A × A non Watson-Crick base pair with other non canonical base pairs adjacent to them. This conformational change in helix caused by the adenosine platform enhances the interaction of the adenosine platform with the non-canonical base pairs. These

adenosine platforms help in developing long range interactions giving rise to tertiary structure.

Kissing loops are formed by the interaction of two nucleic acid hairpin loops having either partially or fully complimentary loops and thus resulting in the formation of a coaxially stacked helix.

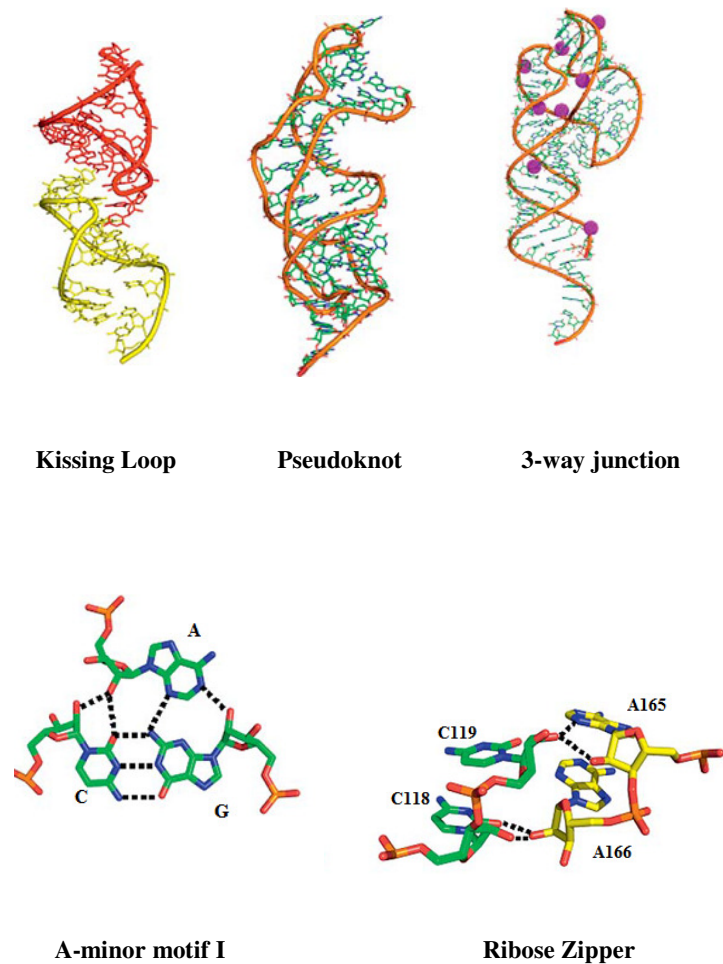

Figure 5 Examples of RNA tertiary structure. RNA backbones are highlighted in red and yellow in the kissing loop and in orange in pseudoknot and 3-way junction. Magnesium ions that are significant for stabilisation and functioning of 3 way junctions are highlighted with magenta spheres. Hydrogen bonds in A-minor motif and Ribose Zipper are highlighted as dotted line.¹⁷

These kissing loops are responsible for gene expression in eukaryotic and prokaryotic organisms and result in stabilisation of the riboswitch structure.

A pseudo knot is formed when a hairpin or internal loop interacts with a complementary single stranded nucleotide through Watson- Crick base pairing. Pseudoknots are only

slightly more stable than two hairpin interactions. Their extra stability is attributed to the interactions between the unpaired base on the bridging loop and the base pairs of the extended helix. These pseudoknots play an important role in various biological activities. These are particularly common in self splicing introns, catalytic core of ribozymes and aptamer domain of riboswitches.^{9, 11, 18}

1.5.2. RNA Junctions

A junction is formed when 3 or more helices come together. 3-way junctions that are commonly known have two helices coaxially stacked and the third helix makes tertiary contact which is several base pairs away (Y- shape). These junctions act as hinges which change their conformation on the binding of a protein or any other small molecule to other parts of the RNA. These RNA junctions have an important biological role to play in riboswitches, ribozymes, RNase P etc.^{9, 11, 19} Higher order junctions such as 4-way, 5-way junctions are also known. The more complicated 5-way and higher junctions are generally composed of 3-way and 4-way junctions.²⁰ These RNA junctions are stabilised by interactions such as coaxial stacking, A-minor and ribose-base interactions.

1.5.3. Cationic Metals

The RNA tertiary structure is thermodynamically stabilised by monovalent or divalent cations (Na^+ , K^+ , Mg^{2+} , Ca^{2+} , Mn^{2+} etc). These ions bind to specific sites at RNA; the monovalent ions, apart from binding to the site, associate with the backbone, thereby shielding unfavourable interactions among negatively charged phosphates. Divalent ions bind to specific regions of RNA to give effectively folded structure. In a three way junction there is metal binding around the region of base stacking. For example in hammerhead ribozyme, the 3 way junction acts as the catalytic core and its functioning is dependent on the concentration of divalent ion. In case of group I self splicing introns, five Mg ions bind to the 3-way helix junction and help in the compact folding of non-canonical loops in the minor groove of double helix. Inside this core there are base stacking and hydrogen bonding interactions. Various processes such as protein synthesis and formation of 70S ribosome depend on the concentration of the metal ion. Divalent metal ions are conserved in the RNA network and apart from stabilising tertiary structure also play an important role in catalytic RNAs.^{21, 22, 23}

1.5.4. A-minor motif

These A-minor motifs are known to stabilise RNA tertiary and quaternary structures. It is the contact of the unpaired adenosine extruded from a secondary element and the minor groove of the receptor helix to form a minor groove triple base interaction. These A-minor motifs are categorised on the basis of 2'-OH position of the adenosine and the 2'-OH position of the receptor helix. The most common type I A-minor has a grid of hydrogen bond interactions and a very well defined shape complementarity between the inserted adenosine and the Watson-Crick base pair receptor. A-minor motif is a common structural element in ribosome and other larger RNAs. Because adenosine contributes majorly to the tertiary structure, it is a highly abundant conserved nucleotide in the 50S ribosomal subunit. A-minor functionally contributes in the discrimination against almost similar tRNA on the ribosome for the process of protein synthesis.^{11, 24}

1.5.5. Ribose Zipper

It is the hydrogen bond interactions between 2'-OH of riboses from different regions of a RNA chain or between different RNA chains. All the interactions observed so far are anti-parallel chain interactions and do not extend beyond two consecutive residues. In ribose zippers there is a high degree of sequence conservation. In ribosomal RNAs most ribose zippers interact with proteins through hydrogen bonding or other electrostatic interactions and are responsible for the functioning and initial assembly of the ribosome.^{9, 11}

1.6. RNA Quaternary Structure

Tertiary structures interact with each other to form a supramolecular organisation known as the RNA quaternary structure.⁹ In pre-RNA splicing, for example, mRNA interacts with five major RNA-protein particle snRNPs; these interact with each other and mRNA. RNA-RNA quaternary interactions are important for mRNA splicing. Bacterial 70S ribosome is a good example to explain quaternary interactions. It consists of large (50S) and small (30S) subunits which complex with mRNA and tRNA. The 50S subunit is made up of 23S rRNA (approx. 2300 nucleotides) 5S RNA (approx 120 nucleotides) and 30 proteins while the 30S subunit comprises 16S RNA (approx. 1500 nucleotides) and about 20 proteins. These structures increase the interface between the small and large subunits and their interactions with mRNA and tRNA. The mRNA

binds with the 30S subunit cleft and its codon interacts with the anticodon of tRNA. RNA secondary structure elements, protein side-chains and metal ions are required for the dynamic interactions among the subunits for protein synthesis. There is interaction of the protein in the bridges with other proteins, RNA and other metal ions. The role of the metal ion is in contacts between the ribosome subunits, the ribosome, tRNA and mRNA during protein translation.^{25, 26}

1.7. HIV-1 Rev Response Element and Life Cycle of HIV

The Rev Response Element is made up of ~350 nucleotides is located in the env coding region (Figure 6) and is highly conserved in different HIV-1.

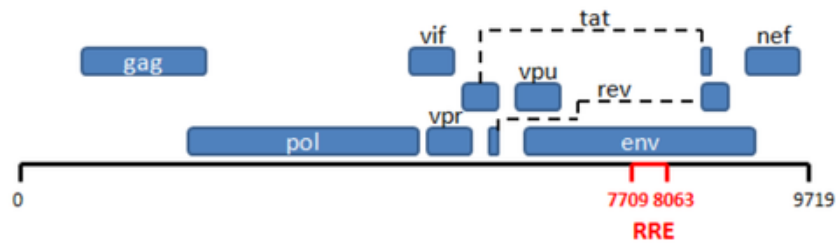

Figure 6 Organisation of HIV genome. RRE lies in the between 7709-8063 nucleotide region.²⁷

It is highly structured and is a *cis* acting element for viral replication. It is present in the partially and unspliced viral mRNA and acts as a framework for the assembly of various Rev proteins. The Rev-RRE oligomeric complex is responsible for exporting the intron containing viral messages from the nucleus to the cytoplasm where it is involved in the synthesis of viral proteins or is packaged as genome for new virions. Due to the small size of HIV-1 it requires multiple reading frames and alternative splicing in order to encode all the viral proteins. Transcription of integrated provirus HIV-1 gives one 9kb pre-mRNA having many splicing sites. In the early stages (Figure 7) the pre-mRNA is spliced fully to give the RRE- free and the 2kb messages which are exported from the nucleus to the cytoplasm via standard pathways. One of the above messages is required to encode the Rev protein and can translocate to the nucleus.

The later phase of the cycle involves the production of the rest of the viral proteins from the RRE-unspliced (9kb) and partially spliced (4kb) messages. Generally these RNAs

containing introns are retained in the nucleus for further splicing or degradation. Nuclear export of these RNAs take place by the multiple assembly of the Rev protein on the RRE, followed by staffing of the host Crm1/Ran-GTP export machinery using a Nuclear Export Sequence.

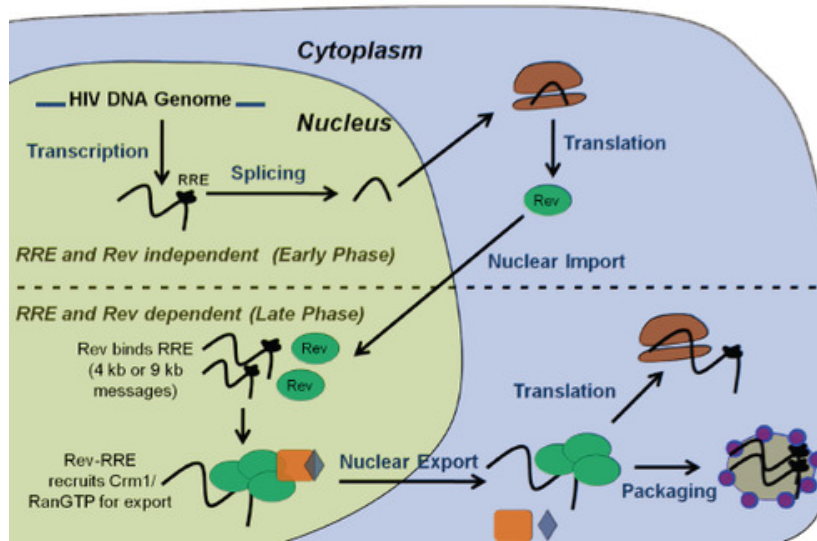

Figure 7 In the early stages of viral life cycle all transcripts are completely spliced and exported in a Rev/RRE independent pathway. A subset of these transcripts code Rev which is then imported to the nucleus. In the later phase, intronic RNA containing RRE then use Rev and nuclear export machinery for transport to avoid splicing and reach cytoplasm where they are translated and packaged as new virion.²⁷

Similarly these messages are translated in the cytoplasm to give the remaining viral proteins or packaged genome for the formation of new virions.²⁷

1.8. Secondary Structure and Rev Binding

According to research carried out previously, RRE secondary structure (Figure 8) was found to be complex and highly branched containing many stem-loops and bulges.²⁸⁻³³ The importance of the secondary structure in Rev binding^{27, 34-38} was established by chemical and enzymatic probing and mobility shift assay studies.^{27, 32, 39} Many Rev proteins bind to the RRE^{27, 40, 41} by the formation of homo-oligomeric Rev-RRE complex which is brought about by both hydrophobic Rev-Rev oligomerisation interactions and Rev-RRE interactions.^{40, 42} Stem IIB is the high affinity site of RRE^{41, 43-45} where most of the binding takes place mediated by 17 residue arginine-rich motif (ARM) in Rev.^{46, 47} The major groove of RNA A-form, which is widened by purine-

binding and oligomeric interactions.⁵⁷⁻⁶¹ Further, the structure, stoichiometry and functioning of the Rev-RRE/Crm1/RanGTP export complex, which is influenced by the Rev-RRE complex, determines the nuclear export competence.

The RRE is an exclusive scaffold which provides a site for assembly of homo-oligomeric complex and these protein binding sites interact with multiple Rev proteins with specific positional and orientation requirement. Viral evolution has thus led to finding binding partners for Rev and increasing the efficiency of such complexes to maximum functionality even under constraints of overlapping protein coding reading frame. The specificity of the Rev for RNA is maintained by the virus which owes its specificity to the three dimensional restraints caused by oligomer formation.⁶²⁻⁶⁸

1.10. 2-Deoxystreptamine aminoglycoside inhibition of HIV RRE/Rev binding

The process of replication of human retrovirus such as HIV involves an ordered pattern of gene expression. Viral gene expression in case of HIV depends on the sequence specific interaction of two viral regulatory proteins namely Tat and Rev. Tat is known to be a transcriptional activator while Rev acts at post transcriptional state to increase the accumulation of viral gag-pol and env messenger mRNAs. Because of their important role in viral replication, Tat and Rev can act as good targets for therapeutic drugs.⁶⁹

Three strategies are known so far that have been implemented to either reduce the levels of these viral regulatory proteins or block their action. The first method involves the introduction of an antisense nucleic acid directed against Rev-mRNA to reduce the level of the Rev protein. The second strategy involves sequestering of the protein by using large excess of a decoy protein that contains high affinity protein binding sites. The third strategy deals with using negative mutant against the regulatory protein. For instance, Rev proteins having mutation at a certain C- terminal inhibit wild type Rev in cotransfection assay. All these strategies suffer from the same difficulty of delivery of the therapeutic drug which is either a nucleic acid or protein in the above cases.⁶⁹

The new strategy involves the specific binding of small organic molecules that inhibit the binding of ligand to the RNA. These molecules are being referred to as 'small molecules' as they have a molecular weight of less than 2000 Daltons and are molecules

other than high molecular weight peptides and oligonucleotides etc. In the RNA/ ligand pair, the RNA can be any ribonucleic acid polymer and the ligand is mostly a protein, nucleic acid, lipid or carbohydrate.⁶⁹

In the case we are dealing with, the ligand of the ligand/RNA pair is the HIV rev protein while the particular RNA element of interest is the *cis* acting element within Rev responsive transcripts known as Rev-Responsive Element. Binding of Rev to RRE takes place in vitro and the binding of the Rev protects a 66 nucleotide fragment of the RRE referred to as the domain II of the RRE. This fragment is sufficient for high affinity Rev binding. Small organic molecules bind to a 67 nucleotide high affinity binding site.⁶⁹

It was observed that Rev-RRE was successfully inhibited by a class of small organic molecules: 2-deoxystreptamine (2-DOS) aminoglycoside. This class consists of molecules having a 2-DOS nucleus bound to one or more sugar moieties via glycosidic linkages.⁶⁹

Structurally these 2-DOS compounds can be further categorised. The conventional method of categorising is based on the position of the substituent on the 2-deoxystreptamine. Another method may involve classifying on the basis of number of sugar moieties attached to the 2-DOS nucleus.⁶⁹

In an experiment conducted by the Green group in USA in 1996, thirteen compounds belonging to the 2-DOS aminoglycoside class (Figure 9) namely: neamine, amikacin, sisomicin, ribostamycin, butirosin, kanamycin B, kanamycin A, tobramycin, gentamicin, neomycin B, paromomycin 1, lividomycin A and hygromycin B were tested for Rev/RRE binding inhibition.⁶⁹

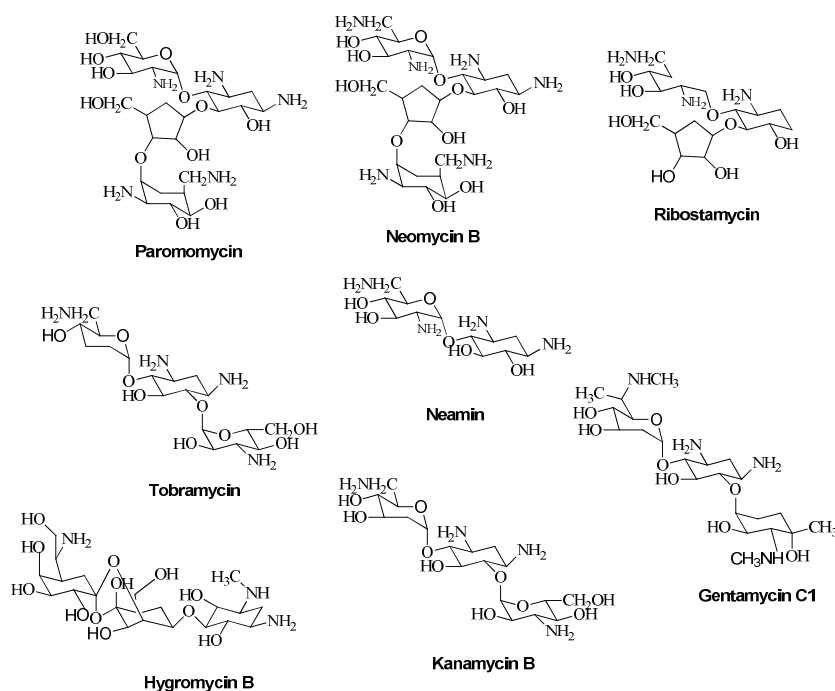

Figure 9 Examples of 2-deoxystreptamine aminoglycosides.

Out of these 13 compounds, 9 (neomycin B, neamine, ribostamycin, lividomycin A, kanamycin B, amikacin, gentamicin C, sisomicin and tobramycin) were found to be effective in inhibiting Rev/RRE interactions and 3 (neomycin B, tobramycin and lividomycin A) had good inhibitory potential. This gave clear evidence that 2-DOS structural unit played an important role in Rev/ RRE inhibition which could be attributed to proper orientation and position of amino and hydroxyl groups that can form hydrogen bond acceptor and donors for RNA bases and provide positively charged amino groups to interact with the phosphate backbone of the RNA.⁶⁹

Various functionalised 2-DOS aminoglycosides have enhanced Rev-RRE inhibition efficiency. The amino and the hydroxyl groups are favourable locations for derivatisation. Such derivatisation may increase the specificity of the compound for RRE or may improve membrane permeability or cellular uptake of the compound. Lipophilic moieties which lead to a decrease in the basicity of amine groups may be favourable for inhibition. Also these derivatives may not act as inhibitors of Rev /RRE as such but might be converted to active inhibitors in the cell.⁶⁹

1.11. Biosynthesis from D-glucose -6-phosphate

The biosynthetic pathway for 2-DOS (Scheme 1) developed is more efficient than many of the chemical routes known till date. In 2005, Kakinuma group was finally able to enzymatically confirm the neomycin biosynthetic gene cluster-Neo A, B and C for the synthesis of 2-DOS in *Streptomyces fradiae*. The initial steps of the carbocycle for the conversion of D-glucose-6-phosphate (**1**) to 2-deoxy-scyllo-inosose (DOI) (**2**) was catalysed by a single enzyme 2-deoxy-scyllo-inosose synthase in the presence of NAD^+ and Co^{2+} as cofactors. This enzyme was first purified from butirosin producing *Bacillus circulans* and its gene *BtrC* was established. In 2003-2004 many research groups were involved in the identification of 2-DOS gene cluster in various actinomycetes such as kanamycin, ribostamycin, neomycin etc. Kakinuma group identified Neo C to possess DOIS activity and thus catalyse the formation of DOI. Subsequent transformation of DOI to 2-deoxy-scyllo-inosamine (DOIA) (**3**) was confirmed to be brought about by gene NeoB which is the L-glutamine: aminotransferase gene.⁷⁰

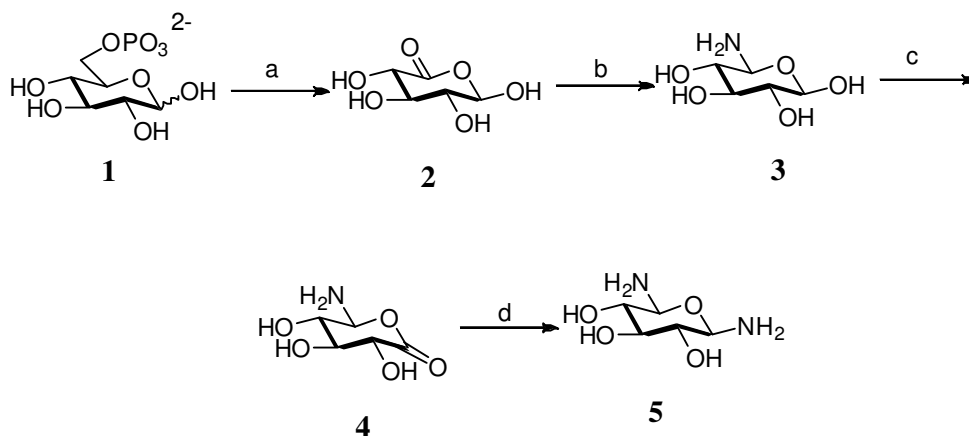

Reagents and conditions: (a) NeoC, NAD^+ , Co^{2+} ; (b) NeoB, PLP, Gln; (c) NeoA, NAD^+ , Zn^{2+} ; (d) NeoB, PLP, Gln.

Scheme 1 Biosynthesis of 2-deoxystreptamine.

NeoA in the presence of NAD^+ and Zn^{2+} was responsible for the subsequent conversion of DOIA to form 3-amino-2,3-dideoxy-inosose (amino-DOI) (**4**). This particular gene was identified to have DOIA dehydrogenase functionality. Since unprotected amino DOI was not particularly known because of complications in its synthesis, the amino-DOI produced by the NeoA was thereafter continuously used for the natural transamination which was reported to have been catalysed by NeoB, PLP and Gln to

obtain the central scaffold for most aminoglycoside antibiotics 2-deoxystreptamine (5).⁷⁰

1.12. Degradation of Neomycin

2-deoxystreptamine can be obtained by degradation of neomycin (Scheme 2). Though this is not exactly a chemical synthesis, it is very frequently utilised in the synthesis of 2-deoxystreptamine due to ease of the process. Neomycin B is mostly used for this purpose due to its easy availability from *Streptomyces*⁷¹ and commercial availability. There are two direct syntheses of 2-DOS from neomycin. The first method involves the reaction of neomycin B (6) with sulphuric acid leading to the cleavage of a specific glycosyl bond to form neamine (7) (also called neomycin A). 2-DOS (5) is obtained by either reaction of neamine with 6 N HCl⁷² or with HBr⁷³ to yield the desired central aminoglycoside scaffold.

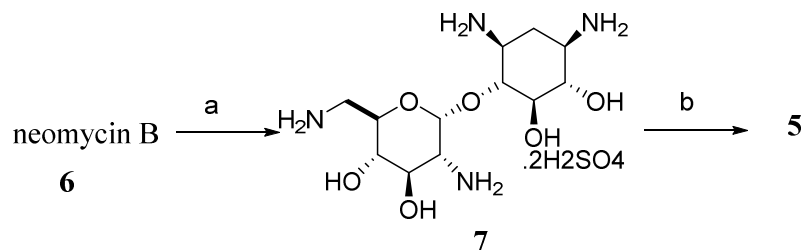

Reagents and condition: (a) H₂SO₄, 79-81%; (b) aq.HBr or 6 N HCl, 50%.

Scheme 2 Degradation of Neomycin method 1.

The second method (Scheme 3), an alternative for the two step method mentioned above, involves a direct complete hydrolysis of neomycin B (6) as discussed earlier by Georgiadis.⁷⁴ 2-DOS (5) in this case is separated from other carbohydrate constituents of neomycin by carrying out steps involving protection of 2-DOS in order to isolate it. The scheme of protection involves the conversion of 2-DOS to the bisazide form by diazotransfer catalysed by either Cu²⁺ or Zn²⁺.⁷⁵ Swayze and group further went on to selectively block the O4 and O5 position using isopropylidene forming a racemic mixture of 8.⁷⁶⁻⁷⁸ This was followed by the protection of the 6th position with 3-

nitrobenzyl and finally the removal of the isopropylidene group to give 11% yield of compound **9**.

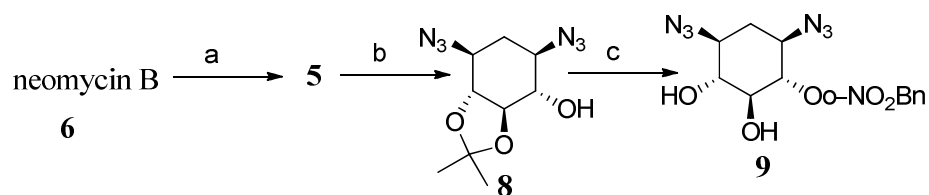

Reagents and condition: (a) aq. HBr, 61%;(b) (i) TfN₃ (ii) DMP, TsOH, 48%; (c) (i) *o*-NO₂BnBr, NaH (ii) aq. AcOH, 37%.

Scheme 3 Degradation of Neomycin method 2.

1.13. De novo Synthesis: Delft's efficient synthesis of 2-DOS

A chemical synthesis scheme (Scheme 4) was established by the Delft group in 2004 in its attempt to come up with a chemical synthesis of the 2-DOS which involved relatively inexpensive starting materials and less number of steps of synthesis. This synthesis starts with a Diel's Alder condensation between *p*-benzoquinone and cyclopentadiene to give **10**.⁷⁹ Reduction of **10** under Luche's conditions gave the diol **11** in 80% yield which was converted into the enone **12** via 1,4 migration of the hydrogen brought about by the improved Takano et al. conditions⁸⁰ of PdCl₂ (dppf). Epoxidation of **12** was carried out with hydrogen peroxide and sodium hydroxide to yield epoxide **13** in 89% yield. The group faced challenges in its attempts to reduce the ketone to alcohol **14** due to formation of Payne rearrangement product along with the major product.

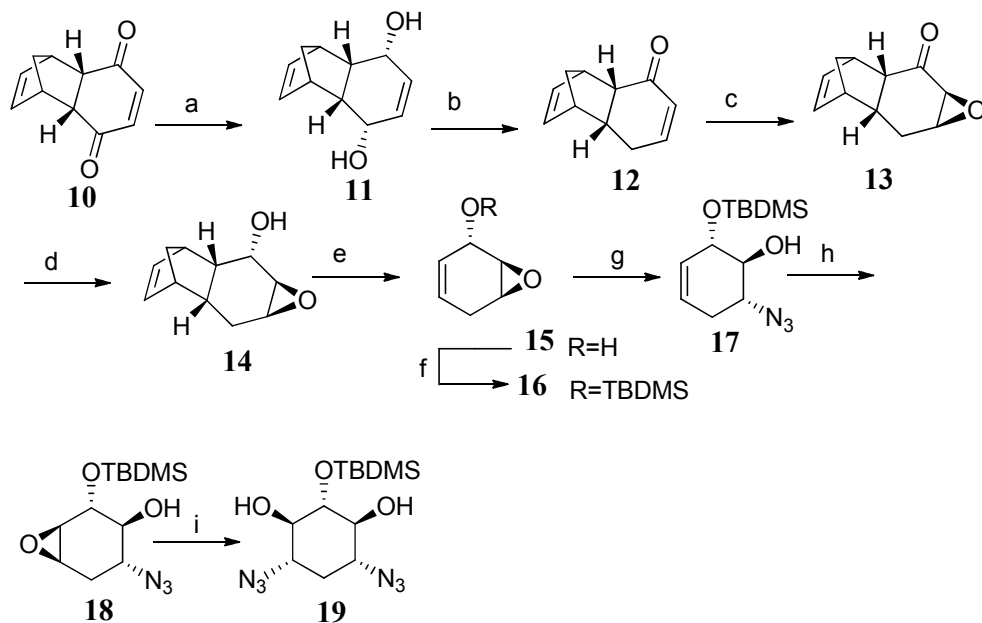

Reagents and conditions: (a) NaBH₄, CeCl₃, 80%; (b) PdCl₂(dppf), 77%; (c) H₂O₂, NaOH, 89%; (d) NaBH₄, CeCl₃, 80%; (e) FVT, 84%; (f) TBDMSCl, 85%; (g) NaN₃, 89%; (h) mCPBA, 72%; (i) Yb(OTf)₃, NaN₃, Et₃N, 79%(BORSM).

Scheme 4 Efficient chemical synthesis of 2-DOS proposed by Delft group

Satisfactory 7:1 ratio of the isomers was obtained by following Luche conditions for reduction at -78 °C. An optimised flash vacuum thermolysis (FVT) with sublimation at 80 °C, thermolysis at 600 °C and 0.04 mbar pressure led to a retro diel's alder to yield 84% of **15**. Further, hydroxyl was protected by tert-butyldimethylsilyl group (**16**) followed by conversion of the epoxide to azido alcohol (**17**). The double bond was converted into epoxide by mCPBA epoxidation to obtain the *trans*-epoxide **18** in 4:1 mixture of the *cis-trans* isomers. Finally Delgado's conditions⁸¹ of chelation controlled Yb(OTf)₃ catalysed azidolysis of epoxide in improvised microwave conditions of 280 W and 135 °C in the presence of molecular sieves gave the desired product **19** in 79% yield. The overall yield of the product was found to be 18% and proved to be more efficient than other chemical routes to 2-DOS explored earlier.

1.14. Synthesis from the Chiral Pool

1.14.1. Synthesis from neamine

Delft group in 2006 came up with a short synthetic route (Scheme 5) to orthogonally protected 2-DOS. This is a seven step synthesis to yield orthogonally protected enantiopure 2-DOS in an overall yield of 28%. The first step involved the hydrolysis of neomycin sulphate (**20**) in modified conditions of water along with MeOH to yield neamine (**21**) in 89% yield. This was followed by conversion of the amino groups into azide (**22**) by treating neamine with triflyl azide.⁷⁵ Dissolving the diazide in 1:1 mixture of acetic anhydride and pyridine in the presence of dichloromethane instead of DMAP as quoted in literature before yielded 5:1 mixture of tri and tetra-acetate in favour of the former.

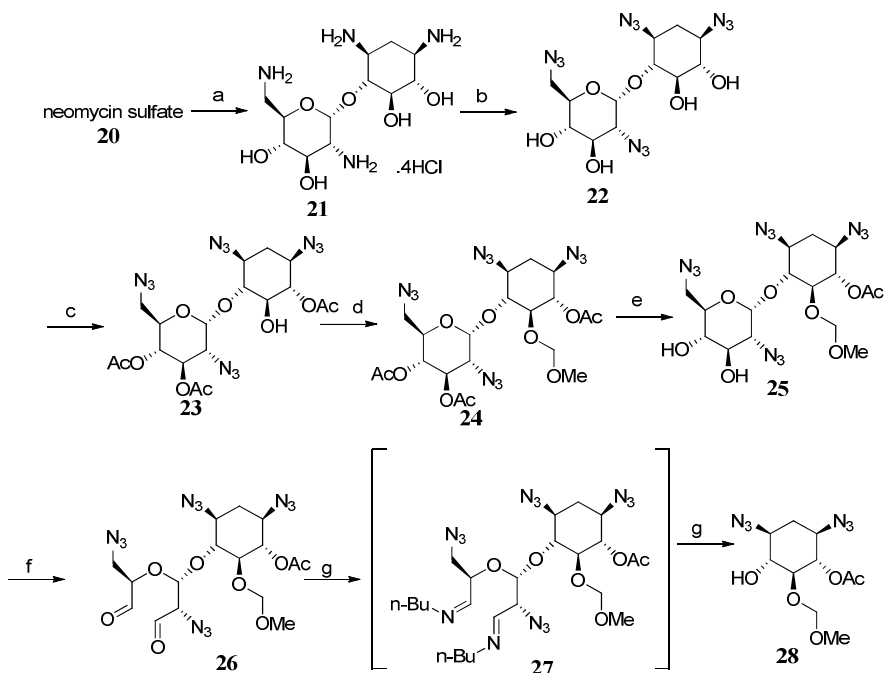

Reagents and conditions: (a) H₂O/MeOH (1:1 v/v), 2N HCl, reflux, 16h, 89%; (b) CH₂Cl₂/MeOH/H₂O (3:10:3 v/v/v), TfN₃, CuSO₄, rt, 3h, 82%; (c) CH₂Cl₂/Ac₂O/pyr (8:1:1 v/v/v), 0 °C, 2h, 69%; (d) CH₂Cl₂/(CH₃O)₂CH₂ (1:1 v/v), P₂O₅, rt, 30 °C, 91%; (e) MeOH, cat KO^tBu, rt, 4h, 87%; (f) THF, NaIO₄, rt, 16h; (g) MeOH, n-butylamine, rt, 1h.

Scheme 5 Synthesis of enantiopure 2-DOS from neomycin.

The required triacetyl product **23** was separated from the mixture by column chromatography. The group then went on to protect the 5-hydroxyl group with methoxymethyl (MOM) group which was accomplished by reacting **23** with

dimethoxymethane and P_2O_5 ⁸² to give **24** in excellent yield. Various conditions for acid hydrolysis for the cleavage of the α -glycoside linkage were tried out but no success was achieved possibly because of the presence of the azido groups. In order to retain the asymmetry of protective groups in 2-DOS, deprotection of acetyl group from glucose moiety was performed keeping the 5'-acetyl group unaffected to yield **25** in good yield. Finally oxidation was carried out with $NaIO_4$ followed by treatment of the formed dialdehyde (**26**) with n-butylamine to yield the β elimination product via diimine intermediate (**27**) formation. Orthogonally protected 2-DOS (**28**) was finally obtained in 72% yield for the last two steps.⁸³

1.14.2. Synthesis of enantiopure protected 2-DOS from D-allylglycine

In 2003, Delft group came up with another synthesis of orthogonally protected enantiopure 2-deoxystreptamine from D-allylglycine. The synthesis (Scheme 6) starts with the formation of the methyl ester of D-allylglycine (**29**). After analysing the shortcomings of the Dodoni⁸⁴ conditions of relatively low de, the group decided to reverse the steps thereby double protecting the amino group with Boc and PMB (**30**) and then treating it with 2-lithio-thiazole followed by the reduction of the ketone using $NaBH_4$. The obtained *syn*- β -amino alcohol (**31**) was found to have a de >95%. O-benzylated derivative of **31** was obtained by its reaction with NaH followed by $BnBr$ in the sequence mentioned (**32**). Due to the suspected interference by the amino protection, the group removed the p-methoxybenzyl group (**33**) with CAN before using Grignard reagent. **34** was obtained after thiazole unmasking and further reacted with vinylmagnesium bromide to obtain 4:1 mixture of **35a** and **35b** which could be readily separated by column chromatography.

After separation using silica gel, followed ring closing metathesis (**36**) and protection of the free hydroxyl⁸⁵ with TBDMS to yield **37** in 82% (for two steps). Subsequently the double bond was dihydroxylated⁸⁶ to yield **38** which took place with exclusive facial selectivity and was further reacted with thionyl chloride and oxidation to give cyclic sulphate **39** in 80% yield.⁸⁷

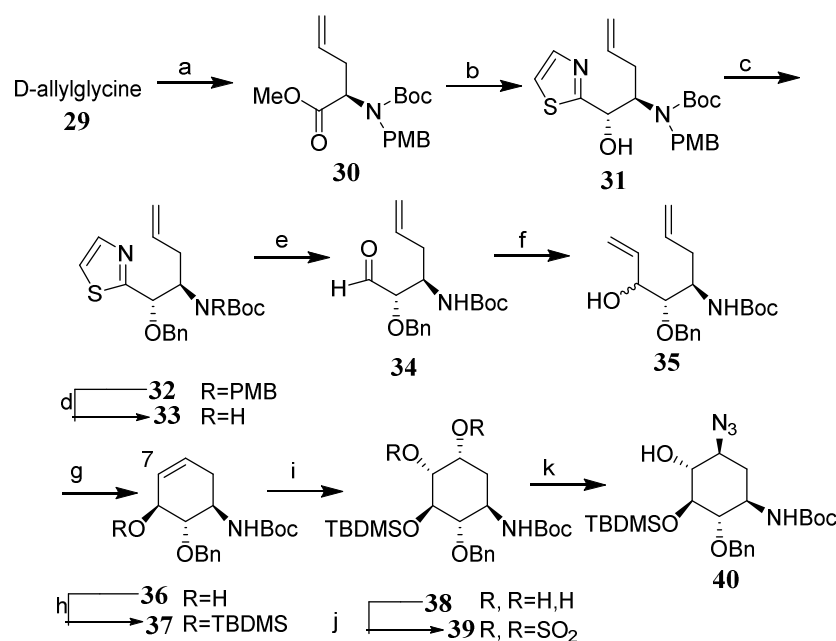

Reagents and conditions: (a) AcCl, MeOH, 2h then Et₃N, p-MeOC₆H₄CHO, CH₂Cl₂, rt, 18 h then NaBH₄, MeOH, 30 min, 0 °C then Boc₂O, dioxane, rt, 18h, 89%; (b) 2- LTT, Et₂O, -78 to -45 °C, 6h then NaBH₄, MeOH, 0 °C, 30 min, 89%, de>95%; (c) BnBr, DMF, 0°C then NaH, 1 h, 90%; (d) CAN, NaHCO₃, MeCN/H₂O(4/1), rt , 30 min, 67%; (e) 4 Å MS, MeOTf, MeCN, rt, 25 min then NaBH₄, MeOH, 0 °C, 10 min then CuCl₂·2H₂O, CuO, MeCN/ H₂O(10/1), rt, 15min, 83%; (f) vinyl MgBr, THF, -78 °C, 4h, **35a** 56%; (g) second generation grubb's catalyst (mono-substituted imidazolylidene ligand), CH₂Cl₂, rt , 2h; (h) TBDMSOTf, Et₃N, CH₂Cl₂, rt, 2h, two steps 82%; (i) RuCl₃, NaIO₄, EtOAc/MeCN/H₂O (3/3/1), 0 °C, 3 min, 70%; (j)SOCl₂, pyridine, EtOAc, 0 °C, 30 min, then NaIO₄, RuCl₃·H₂O, CH₂Cl₂/MeCN/H₂O (2/2/3), 0 °C, 1h, 80%; (k) LiN₃, DMF, heat, 4h then H₂SO₄, THF, H₂O, rt, 30min, 60%.

Scheme 6 Synthesis of enantiopure protected 2-DOS from D-allylglycine.

Opening of the cyclic sulphate regioselectively with lithium azide followed by sulphate hydrolysis yielded the enantiopure 2-deoxystreptamine derivative (**40**).

1.14.3. Synthesis of orthogonally protected 2-DOS from α -glucopyranoside

The synthesis by Bauder (Scheme 7) developed in 2008, starts with the protection of C6 hydroxyl group of methyl α -glucopyranoside (**41**) with a tosyl group to obtain **42** in 92% yield by crystallisation from MeOH.^{88,89} The tosyl group was then substituted by iodide to give **43** in 93% yield.⁸⁸ Dehydroiodination of **43** with DBU (1,8-diazabicyclo[5.4.0]undec-7-ene)⁹⁰⁻⁹⁴ in toluene was carried out successfully to obtain enopyranoside (**44**).⁸⁸ This enone was refluxed in a mixture of acetone-H₂O-AcOH in

the presence of $\text{Hg}(\text{OAc})_2$ to carry out Ferrier carbocyclic ring-closure and yield β -hydroxy-cyclohexanone (**45**) in 69% after recrystallization in CH_2Cl_2 .^{88, 95} The first amine group was developed at the carbonyl site through oxime precursor by reacting **45** with *o*-benzylhydroxylamine in EtOH-pyridine to obtain benzyloxime (**46**) in 93% yield. The imino bond was reduced with diastereofacial selectivity control, in the presence of TBAH, a mild and selective reducing agent, in MeCN-TFA (152 equivalents of TFA) for 2 hours to give **47** in 94% yield. Finally to convert the axial hydroxyl group at C1 to equatorial azide group, **47** was reacted with triphenylphosphine (Ph_3P), diisopropylazodicarboxylate (DIAD) and DPPA to yield the azide (**48**) in 65%. Overall stereocontrol was achieved for all the conversions.⁹⁶

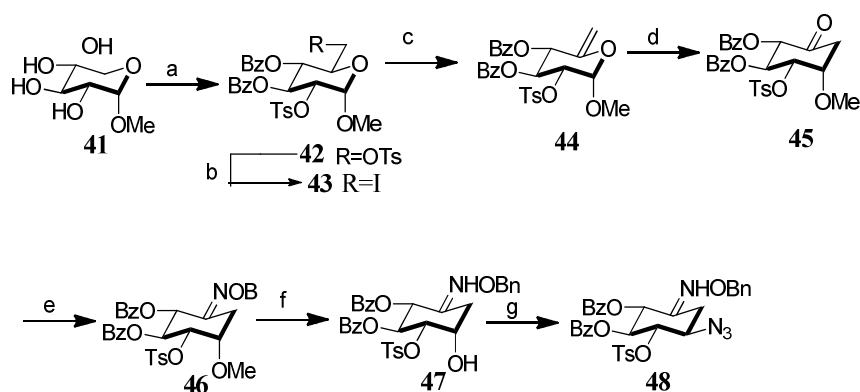

Reagents and conditions: (a) pTsCl, BzCl, pyridine, rt, 24 h, 92%; (b) NaI, Ac_2O , reflux, 93%; (c) DBU, PhMe, 80 °C, 15 h, 68%; (d) $\text{Hg}(\text{OAc})_2$, acetone, H_2O , AcOH, 70 °C, 2.5h, 69%; (e) $\text{BnONH}_2 \cdot \text{HCl}$, EtOH, pyridine, rt, 6h, 93%; (f) $\text{Me}_4\text{NBH}(\text{OAc})_3$, TFA, 0 °C, 2h, 93%; (g) DPPA, Ph_3P , DIAD, rt, 7h, 65%.

Scheme 7 Synthesis of orthogonally protected 2-DOS from α -glucopyranoside.

1.15. Asymmetrization of meso 2-deoxystreptamine

1.15.1. Orsat Resolution

The easiest method (Scheme 8) to obtain enantiopure 2-deoxystreptamine would involve the resolution of meso 2-deoxystreptamine obtained by hydrolysis of neomycin which can be owed to the easy commercial availability of neomycin. The first resolution was carried out by Orsat et al. in 1996 through combined action of the catalase subtilisin BPN[®] and diallyl carbonate in HEPES buffer that resulted in the conversion of meso 2-deoxystreptamine (**5**) to **49** in a yield of 76% and very high selectivity of > 99% ee.⁹⁷

Comment: Previous students in the Berrisford group have failed to reproduce this methodology.

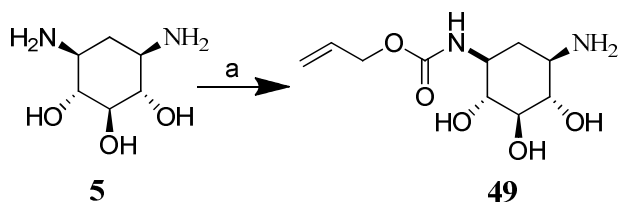

Reagents and conditions: (a) diallyl carbonate, subtilisin BPN', HEPES buffer, DMF, rt, 1 week, 76%, >99% ee.

Scheme 8 Orsat Resolution

1.15.2. Prinzbach Resolution

A second resolution (Scheme 9) was carried out around the same time that involved the incubation of suspension of *N, N'*-diphenylacetyl protected 2-deoxystreptamine (**50**) in a 4:1 phosphate buffer: DMF mixture for 18 days maintained at 25-35 °C with *Penicillin amidase* which was followed by acetylation to yield *N*-acetyl-*N'*-phenylacetyl protected derivative (**51**) having high enantioselectivity.⁹⁸

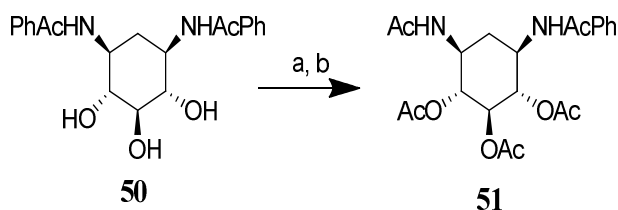

Reagents and conditions: (a) penicillin amidase, 0.2M phosphate buffer (pH 7.6); (b) Ac₂O, pyridine, DMAP, N₂, rt, 18 days, 83%, >97% ee.

Scheme 9 Prinzbach Resolution

1.15.3. Wong Enzymatic Resolution

Wong carried out the desymmetrization of diazido derivative of 2-deoxystreptamine (**5**) by both enzymatic as well as chemical methods.⁹⁹ The enzymatic approach (Scheme 10) involved the conversion of 2-DOS to diazido triacetyl derivative (**52**) via a diazotransfer with triflyl azide in the presence of Cu²⁺ catalyst which was subsequently followed by

reaction with acetic anhydride. A further enantioselective deacetylation was carried out in the presence of a resin-immobilised lipase Novozym 435 which gave 71% yield of **53**.

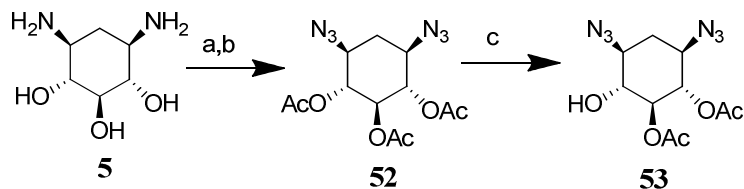

Reagents and conditions: (a) TfN₃, Et₃N, CuSO₄, MeOH/CH₂Cl₂, rt, 21h; (b) Ac₂O, pyridine, rt, 19h, 75% for two steps; (c) *Candida antarctica* lipase, 1:1 toluene/phosphate buffer, pH 6.2, rt, 72h, 71%.

Scheme 10 Wong Enzymatic Resolution

1.15.4. Wong Chemical Resolution

Wong's chemical route (Scheme 11) used Ley and co-worker's¹⁰⁰ chiral dispiroketal-desymmetrization approach. In this method **52** was deacetylated and the resulting triol (**54**) was reacted with (2*R*, 2*R'*)-bis(diphenyl)-6,6'-bis(3, 4-dihydro-2*H*-pyran) (PDHP) and catalytic camphorsulfonic acid in refluxing chloroform and was subsequently acetylated to yield the major isomer **55** in 50%. Deacetylation of **55** yielded **56** that could glycosylate selectively at the 4th position.

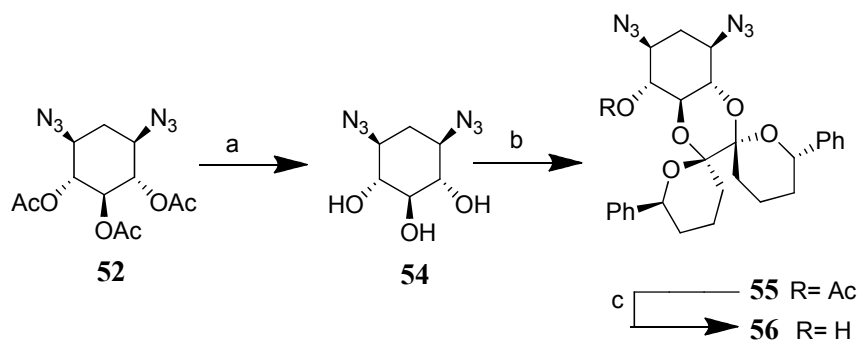

Reagents and conditions: (a) NaOMe, MeOH, rt, 2.5 h, 100%; (b) (i) Ley bisdihydropyran, CSA, CHCl₃, reflux, 18h; (ii) Ac₂O, DMAP, pyridine, rt, 24h, 50% over two steps; (c) NaOMe, MeOH/dioxane, rt, 21h, 90%.

Scheme 11 Wong Chemical Resolution

1.16. Synthesis of analogue of 2-deoxystreptamine - 2,5-dideoxystreptamine

1.16.1. Synthesis of meso-2,5-dideoxystreptamine

There are a few methods for the synthesis of 2,5-dideoxystreptamine.

Reaction of 1,4-cyclohexadiene (**57**) with N-Bromosuccinimide in water (Scheme 12) yielded the bromohydrin (**58**) in 65-88% depending on the source NBS was obtained from. This bromohydrin (**58**) was further reacted with m-chloroperbenzoic acid or monoperothalic acid to yield epoxybromohydrin isomers **59a** and **59b** in 90% yield.¹⁰¹ The ratio of the isomers could slightly be altered with the change in temperature i.e. the ratio of **59a** to **59b** changed from 85:15 to 75:25 when the temperature was increased from 0 °C to 25 °C. The *cis* bromohydrin **59a** was separated from the isomer mixture and was purified by several recrystallizations. The *cis* bromohydrin was simply treated with a base to yield the bisepoxide **60a**.¹⁰²

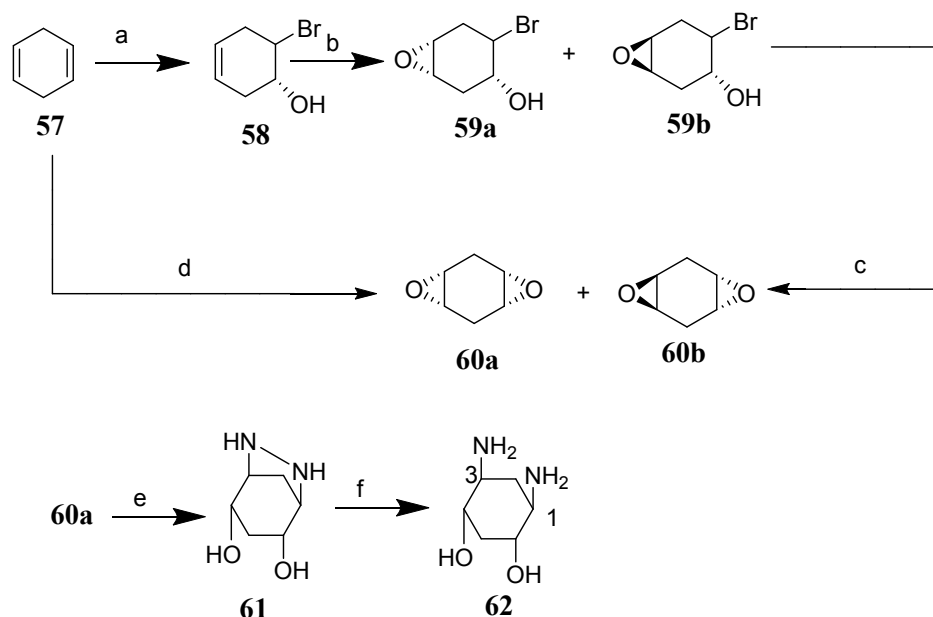

Reagents and conditions: (a) NBS, H₂O, 65-88%, rt, 3h; (b) mCPBA, CH₂Cl₂, 0 °C, 24h, 90% (85% *cis*, 15% *trans*); (c) aq NaOH, rt, 1hr, 90%; (d) mCPBA, 0 °C, 16h, 95%; (e) anhydrous NH₂-NH₂ in dry EtOH, reflux under N₂, 16h, 84.5%; (f) 1:1 glacial CH₃COOH-H₂O, Pd/C under H₂, 60 °C, 50psi, column containing Rexyn 201 washed with H₂O.

Scheme 12 Synthesis of 2,5-dideoxystreptamine.

Bisepoxide could conveniently be obtained by reaction of 1,4-cyclohexadiene with *m*-chloroperbenzoic acid to yield mixture of *cis* (**60a**) and *trans* bisepoxide (**60b**) in 90% yield.¹⁰² The *cis* isomer was found to be the predominant isomer in the above mixture. The ratio of the *cis* (**60a**) and *trans* (**60b**) isomers could be varied slightly by changing the temperature i.e. the ratio of **60a** to **60b** changed from 70:30 to 63:37 on variation of temperature from 0 °C to 25 °C. The *cis* isomer could be separated from the mixture by liquid-liquid extraction. On the basis of the dipole moment of the *cis* and *trans* isomer it could easily be predicted that *trans* isomer will have higher partition coefficient in ether-water and petroleum ether-water systems. Extracting with an aqueous solution and ether or repetitive extraction with petroleum ether successfully removed the *trans* isomer and the remaining aqueous layer containing the *cis* isomer could be extracted using suitable organic solvent.⁹⁹

2,5-deoxystreptamine (**62**) could be obtained from the *cis*-bisepoxide (**60a**) by reacting it with hydrazine to yield (**61**) followed by hydrogenolysis. The mechanism (Scheme 13) was predicted to involve the attack of one of the epoxide ring by hydrazine that would lead to the opening of the ring diaxially to give (**63**). This was anticipated to be followed by the attack of the hydrazine group at the 3rd position instead of the 4th, in accordance with the diaxial opening rule.¹⁰²

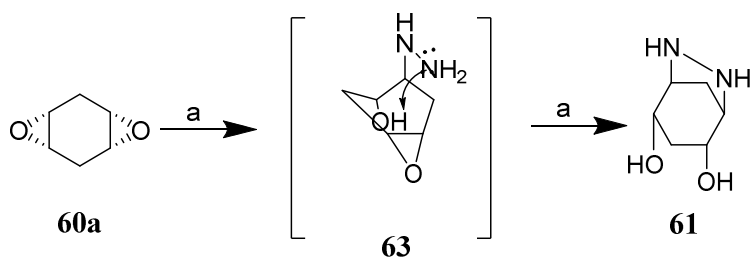

Reagents and conditions: (a) anhydrous $\text{NH}_2\text{-NH}_2$ in dry EtOH, reflux under N_2 , 16h, 84.5%.

Scheme 13 Mechanism of reaction of hydrazine with bisepoxides.

Experimentally, reaction of **60a** with hydrazine in ethanol yielded 1,3-hydrazino compound (**61**) in 85%. This was followed by hydrogenation in aqueous acetic acid in

the presence of Palladium catalyst¹⁰³ that gave the acetate salt of (**62**) in 78% yield. Subsequent reaction with an anion exchange resin gave the free base (**62**).¹⁰²

1.16.2. Desymmetrisation of the obtained 2,5-dideoxystreptamine

Reacting (**62**) with ethylchloroformate in aqueous methanol in the absence of base yielded a mixture of mono-carbethoxy (**64**) in 53% and bis-carbethoxy (**65**) compound in 23%. **64** could be separated from the mixture easily (Scheme 14). The hydrogen chloride generated during the reaction prevents the acylation of the second amino group. The presence of base was avoided in the procedure otherwise the reaction would predominantly yield the bis-carbethoxy derivative.¹⁰²

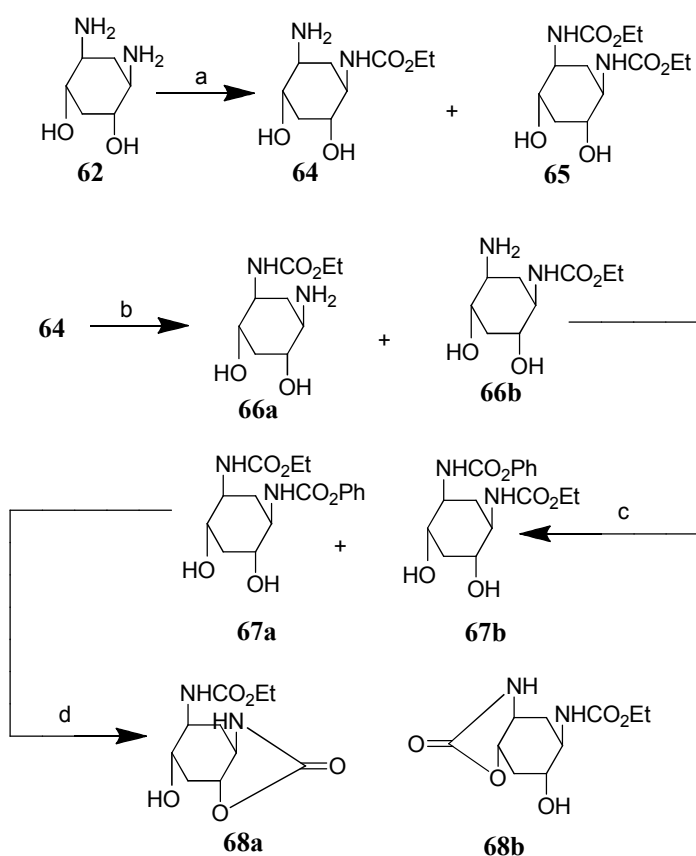

Reagents and conditions: (a) EtClO₂, methanol, 4-6 °C, 1h, 22.8% (**65**), 52% (**64**); (b) (-)/(+)-2-nitrotartronic acid, 95% ethanol-water, rt, 16h; column with Rexyn 201, wash with NaOH, dist. water, 96%; (c) NaHCO₃ in H₂O, acetone, phenylchloroformate, 0 °C, 1h, 91.5% (**67a**) and 88.5% (**67b**); (d) Et₃N, 90% acetone-water, Dowex 50W-X4 resin (H⁺ form), rt, 5h, 92.5% (**68a**), 92.5% (**68b**).

Scheme 14 Desymmetrization of 2,5-dideoxystreptamine

This mono-carobethoxy compound was resolved into its optical isomers **66a** and **66b** by treating with 2-nitrotartranilate salts. The reaction of **64** with (-)-2-nitrotartranilic acid¹⁰⁴ yielded a tartranilate salt from which the free base **66a** ($[\alpha]_D = +37.3$) was produced by treatment with anion exchange resin. The free base **66b** ($[\alpha]_D = -37.6$) was produced similarly by reacting with (+)-2-nitrotartranilic acid.¹⁰²

Umezawa¹⁰⁵ et al.'s general procedure was applied for conversion of **66a** and **66b** to their respective cyclic carbamates. **66a** was reacted with phenylchloroformate in aqueous acetone in the presence of sodium bicarbonate to yield **67a** in 91%. Reacting this crystalline product with triethylamine in aqueous acetone yielded 92% of **68a**. Same series of reactions yielded carbamate **68b** from **67b** in good yield.¹⁰⁴

1.17. Other routes to synthesis of 2,5-dideoxystreptamine

1.17.1. Alternate Route to 2,5-dideoxystreptamine

Oxidation of **61** with hydrogen peroxide¹⁰⁶ yielded the azo compound **69** (Scheme 15).¹⁰⁷In another synthesis the bisepoxide **60a** synthesized in the above synthesis was opened regioselectivity using benzylamine¹⁰⁸ at 150 °C to give **70** after recrystallisation in excellent yield of 94%. This was subsequently followed by hydrogenolysis and azide transfer to yield **71**. The acetylation of **69** and **71** with acetic anhydride in pyridine yielded corresponding acetates **72** and **73**.¹⁰⁷

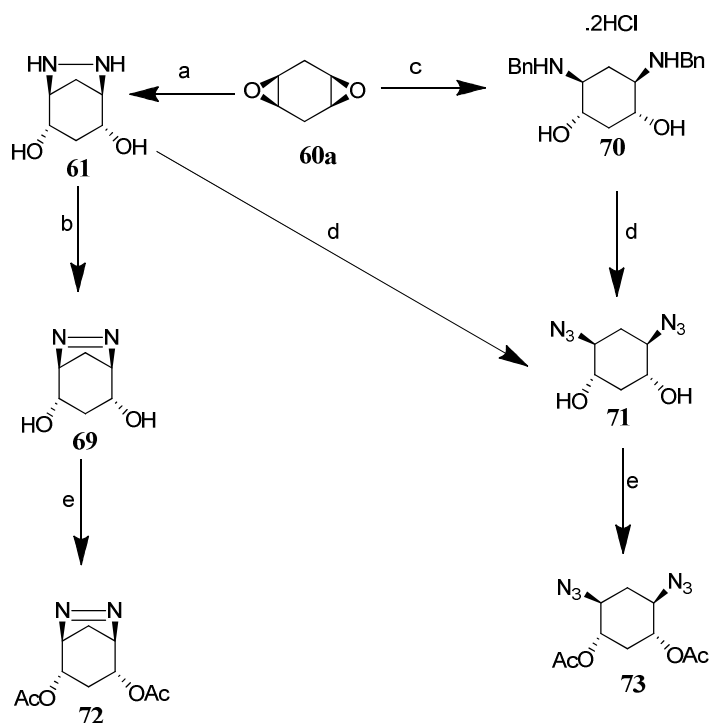

Reagents and conditions: (a) anhydrous $\text{NH}_2\text{-NH}_2$ in dry EtOH, reflux under N_2 , 16h, 84.5%; (b) H_2O_2 , H_2O , rt, 3 days, 52%; (c) BnNH_2 , 150 °C, 24h, 94%; (d) (i) Pd/C, AcOH/ H_2O , 60 °C, 3days, 90% from **61**, 100% from **70**; (ii) TfN_3 , ZnCl_2 , Et_3N , CH_2Cl_2 / $\text{MeOH}/\text{H}_2\text{O}$, 0 °C, 2h, 53% from **61**, 61% from **70**; (e) Ac_2O , pyridine, 16h, rt, 60% for **72**, 81% for **73**.

Scheme 15 Second Route to Synthesis of 2,5-dideoxystreptamine

1.17.2. Desymmetrisation for the formation of 2,5-dideoxystreptamine

Diol **69** was reacted with *Candida rugosa* lipase (CRL) in vinyl acetate at 21 °C for 3 days to yield optically active **74** in 63% yield and enantiomeric excess of 92% ee. Formation of the corresponding diacetate **72** hinders the enantiopurity of the reaction. Also the hydrolysis of diester **72** in the presence of pig liver esterase (PLE) in phosphate buffer yielded the same monoester **74** in 92% and enantiomeric excess of 90%. (Scheme 16)¹⁰⁷

The hydrolysis of diacetate **73** using Wong et al.⁹⁹ enzymatic desymmetrisation of CAL-B yielded the monoester **75** in low yields of 32% and ee of 99%. Also, acylation of diol **71** by reacting it with CRL in vinyl acetate yielded 85% of **75** in a high enantiomeric excess of $\geq 99\%$.¹⁰⁷

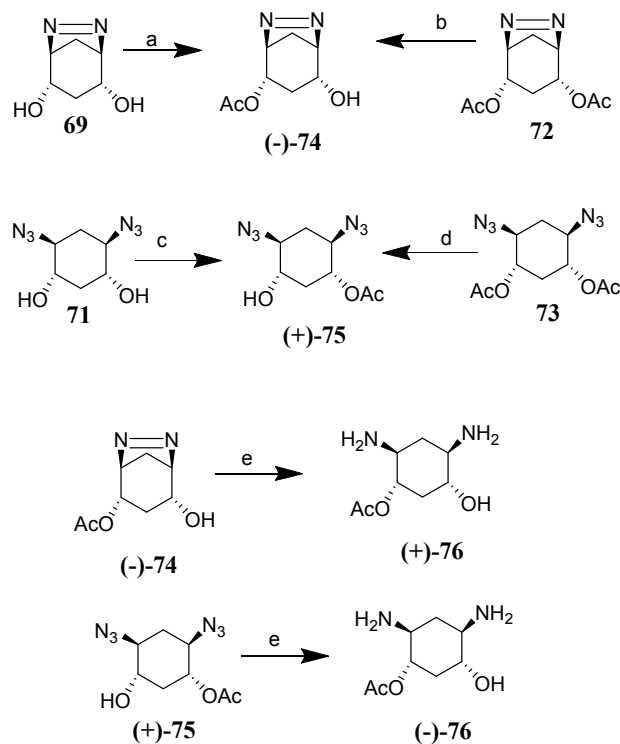

Reagents and conditions: (a) *Candida rugosa* lipase, vinyl acetate, rt, 3days, 63%, 92% ee; (b) *pig liver esterase*, phosphate buffer, pH 7.7, 2h, 92%, 90% ee; (c) *Candida rugosa* lipase, vinyl acetate, rt, 2days, 85%, $\geq 99\%$ ee; (d) *Candida antarctica* lipase B, phosphate buffer, pH 6.2/toluene (1:1), rt, 3days, 32%, $\geq 99\%$ ee; (e) H₂, Pd/C, MeOH, rt, 5h, 93% for (+)-76 and 96% for (-)-76.

Scheme 16 Desymmetrisation of 2,5-dideoxystreptamine analogues

Hydrogenation of (-)-74 was carried out in methanol in the presence of 10% Pd/C gave the dideoxystreptamine monoester (+)-76. On the other hand the opposite isomer (-)-76 was obtained by hydrogenation of (+)-75 under the same conditions.^{107, 109}

1.18. Project Aim

Small molecule ligands that are capable of binding to RNA, less toxic and better inhibitors are of great interest to researchers. For the bioavailability of a drug like molecule in a cell, its molecular weight should not exceed 500. Manipulation to these scaffolds can help in creating a combinatorial library of diverse compounds.

The ring B of neomycin B i.e. 2-Deoxystreptamine is a common motif in various aminoglycoside antibiotics. Though the 2-DOS is responsible for important contacts with the HIV1-RRE during binding, it is not able to show inhibitory activity on its own. Thus, 2-deoxystreptamine provides a scaffold for building a library by appending different functionality on the heteroatoms. The stereochemistry of 2-deoxystreptamine is of high importance for the inhibitory activity of the molecule.

A scaffold of intermediate complexity i.e. 2,5-dideoxystreptamine (Figure 10) will be considered for further studies. Many methods have been published till date for the synthesis of 2,5-dideoxystreptamine. Method involving bis-epoxidation of 1,4-cyclohexadiene followed by nucleophilic ring opening with hydrazine and subsequent reductive cleavage with Pd has scope of further research.

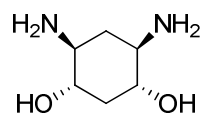

Figure 10 2,5-dideoxystreptamine 5

Also development of new techniques for the synthesis of 2,5-dideoxystreptamine analogues by synthesis of nitro compounds still remains an untouched field. Strategies involving Henry nitroaldol reaction for formation of nitroalcohols and subsequent ring closing to give cyclic compounds and other techniques to prepare 2,5-dideoxystreptamine analogues from nitro compounds, prepared by direct nitration of bromides, provide a great avenue for further research on novel techniques for 2,5-dideoxystreptamine synthesis.

The project aims at developing novel strategies for 2,5-dideoxystreptamine analogue by using 'nitro' chemistry.

CHAPTER 2. RESULTS AND DISCUSSIONS

2.1. 2,5-dideoxystreptamine

It is important to synthesise molecules that have RNA binding capabilities but are less toxic and have greater bioavailability than the known aminoglycosides. This can be made possible by mimicking a core binding motif that contains the required biologically relevant substituents for mRNA recognition. Inclusion of amino alcohol structural motif of 2-deoxystreptamine, which have known phosphate binding potential and other phosphodiester moieties that have electrostatic or hydrogen bond forming capabilities are an excellent source for the basic skeleton of such molecules which can act as potential RNA recognition drugs.

2-Deoxystreptamine (**5**) which is the core subunit of most aminoglycosides cannot show biological activity on its own. It is the key phosphodiester recognition segment of an aminoglycoside and therefore presents a promising scaffold to build a library of aminoglycosides. Varying functionality and structure in this scaffold to achieve a structural motif having maximum RNA recognition, minimum toxicity and good bioavailability is the challenge at hand.

To begin with, 2,5-dideoxystreptamine (**62**), a molecule of intermediate complexity, was chosen as the scaffold. It retains the two amino and two alcohol functionalities of the 2-deoxystreptamine scaffold. The stereochemistry of the 2-deoxystreptamine ring is maintained in the new scaffold i.e. the two alcohols are *cis* to each other; the two amino groups are *cis* to each other; the amino and the alcohol groups lie *trans* to each other.

The stereochemistry of the amino alcohol motif plays a major role in phosphate recognition. The phosphate binding is reduced in the case of *cis* 1,2 amino alcohol.

2.2. Literature Synthesis of 2,5-dideoxystreptamine

Synthesis of 2,5-dideoxystreptamine (**62**) from 1,4- cyclohexadiene (**57**) is already available in the literature. It involves the synthesis of *cis*-bisepoxide (**60a**) followed by the opening of the ring with hydrazine (**61**) and subsequent reductive cleavage. (Scheme 17)¹⁰²

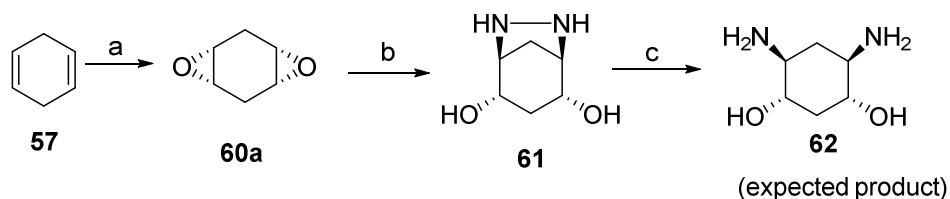

Reagents and conditions: (a) mCPBA, CH_2Cl_2 , 0°C , 5h, 5%; (b) anhydrous $\text{NH}_2\text{-NH}_2$ in dry EtOH, reflux under N_2 , 16h, 70%; (c) 1:1 glacial $\text{CH}_3\text{COOH-H}_2\text{O}$, Pd/C, 60°C , 50 psi, 7h.

Scheme 17 Synthesis of 2,5-DDOS

NOTE: Though literature evidence of formation of 62 from 61 was available, step (c) could not be carried out due to the low amount of 61 obtained from the previous step.

The procedure started with the direct bisepoxidation of 1,4-cyclohexadiene (**57**) which yielded the *cis* isomer (**60a**) as the major product. The 1,4-cyclohexadiene was added to a solution of mCPBA in dichloromethane at 0°C to give a mixture of *cis* and *trans* products and were separated by selective extraction from the aqueous layer to dichloromethane to give the *cis* isomer and to ether layer for the *trans* isomer in the ratio of 9:28 in favour of the *trans* product. This procedure of direct epoxidation gave a poor yield (5% for *cis* and 14% for the *trans* isomer) and the *trans* isomer was obtained as the major product. According to literature, 70:30 mixture of the *cis* to *trans* isomer was obtained at 0°C in favour of *cis* isomer. In order to improve the ratio of *cis* to *trans* bisepoxides the reaction temperature was reduced to -30°C . The *cis* and *trans* isomers were obtained in 42:35 ratio in favour of the *cis* compound.¹⁰²

Due to the low yields of the procedure mentioned above, an alternate route (Scheme 18) to bisepoxides was employed. 1,4-Cyclohexadiene (**57**) was reacted with N-bromosuccinimide in water/dioxane to yield the bromohydrin (**58**) in 61% yield. Treating the obtained bromohydrin with mCPBA in dichloromethane at room temperature yielded a 3:1 mixture of *cis* and *trans* epoxy bromohydrins **59a** and **59b** in favour of the *cis* epoxide.¹⁰²

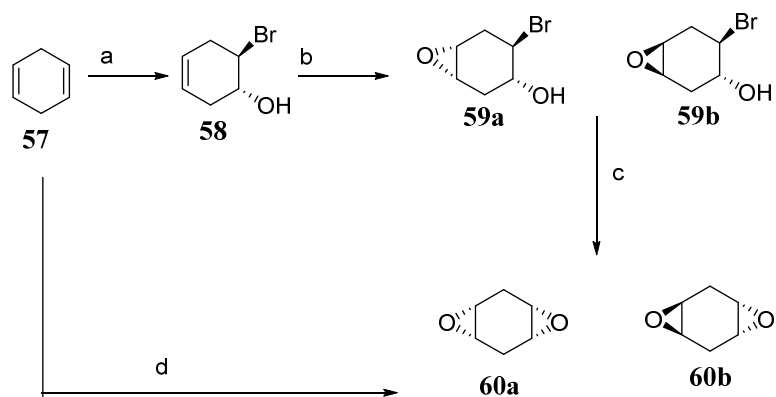

Reagents and conditions: (a) NBS, dioxane, H₂O, rt, 3h, 61%; (b) mCPBA, CH₂Cl₂, rt, 24h, 40%; (c) K₂CO₃, MeOH, rt, 3h, 43% 60a, 12% 60b; (d) mCPBA, CH₂Cl₂, 0°C, 5h, 5%.

Scheme 18 Synthetic routes to the bisepoxidation of 1,4-cyclohexadiene

The mechanism involved in the epoxidation of homoallylic alcohol has been reported in literature. The free hydroxyl directs the incoming peracid by forming a hydrogen bonded complex with it (Figure 11).¹¹⁰ The mechanism was verified by the formation of the *cis* epoxy alcohol (**59a**) as the major product.

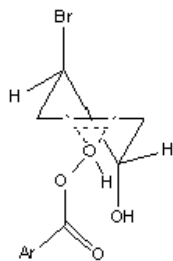

Figure 11 Intermediate formation in epoxidation of bromohydrin 59a (Mechanism).

The *cis* epoxide (**60a**) was finally obtained by the reaction of the epoxyalcohol with methanol and K₂CO₃. No extraction procedure was followed due to the chances of losing product during re-extraction and thus K₂CO₃ was simply filtered off and the mixture of *cis* and *trans* bisepoxide was passed through a column and could be easily separated because of the large difference in R_f values (0.34 for *cis* and 0.75 for *trans*

isomer). The *cis* isomer was separated with a percentage yield of 43% while *trans* bisepoxide was obtained in 12% yield.

Comparison of the NMR values showed variation in methylene protons of the isomers where the *cis* isomer gave a broad quartet while the protons of *trans* isomer showed up as a singlet.

To further improve yields, a reaction given in literature (Scheme 19) to yield monoepoxide by treating 1 equivalent of 1,4-cyclohexadiene with 1.1 equivalents of mCPBA in the presence of K_2HPO_4 was carried out and yielded the monoepoxide (**77**) in 62%.¹¹¹ A second reaction was carried out by reacting 1 equivalent of the 1,4-cyclohexadiene with 2.2 equivalents of mCPBA to yield a 4:1 mixture of *trans* and *cis* isomer in favour of the *trans* isomer. Thus this method failed to improve the yield of the *cis* isomer.

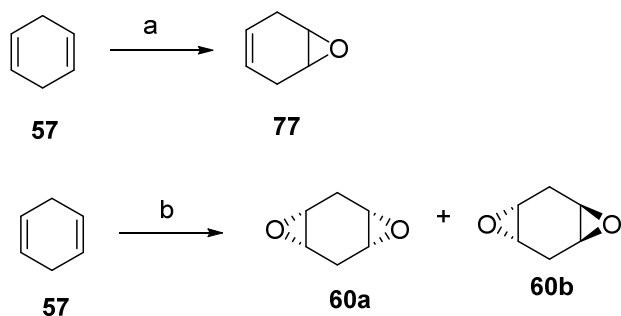

Reagents and conditions: (a) 1.1 eq mCPBA, K_2HPO_4 , CH_2Cl_2 , H_2O , rt, 18h, 62%;
(b) 2.2 eq mCPBA, K_2HPO_4 , CH_2Cl_2 , H_2O , rt, 18h, 8% **60a**, 34% **60b**.

Scheme 19 Synthetic routes to mono and bisepoxides using mCPBA and K_2HPO_4

Obtained *cis* epoxide was refluxed in 1 equivalent hydrazine in ethanol which resulted in 1,3 nucleophilic ring opening to yield the bicyclic compound **61** in 70% yield.(Scheme 17). It was predicted that one of the rings in the bisepoxide would initially open diaxially to give an intermediate (Figure 12) by the attack of a hydrazine molecule while the second epoxide ring of the molecule would subsequently undergo an intramolecular attack by hydrazino group at position 3 rather than 4 as expected by the rule of diaxial opening.¹⁰²

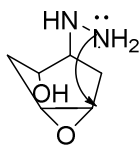

Figure 12 Nucleophilic ring opening of the cis epoxide 60a

Further reaction of this bicyclic compound with 1 equivalent of glacial acetic acid and water would yield the desired 2,5 dideoxystreptamine (**62**), according to literature (Scheme 17). But due to low yields further reaction of the bicyclic compound was not carried out.¹⁰²

Due to the low yields of the epoxide route to 2,5-dideoxystreptamine, research on novel strategies towards 2,5-dideoxystreptamine were carried out. Strategies involving nitro compound synthesis were investigated.

2.3. Novel Route to 2, 5-dideoxystreptamine – General Strategy A

Novel routes (Scheme 20) to synthesis of 2,5- dideoxystreptamine and analogues were looked into to substitute the low-yield epoxidation reaction. By careful analysis of literature it was realised that not much progress had been made in the research on methods of synthesis of such motifs. Various syntheses of nitro compounds were studied for this purpose. A method involving synthesis of nitroalkenes (**78**) which could further undergo cross metathesis with aldehyde substituted alkenes (**79**) were carefully analysed. These compounds containing nitro and aldehyde substituents (**80**) could be made to undergo intramolecular nitroaldol reaction to yield rings (**83**) of any size depending on the nitro compound and aldehyde chosen. These nitroalcohol compounds could then be substituted with various groups at the double bond to create a library of 2,5-dideoxystreptamine analogues.

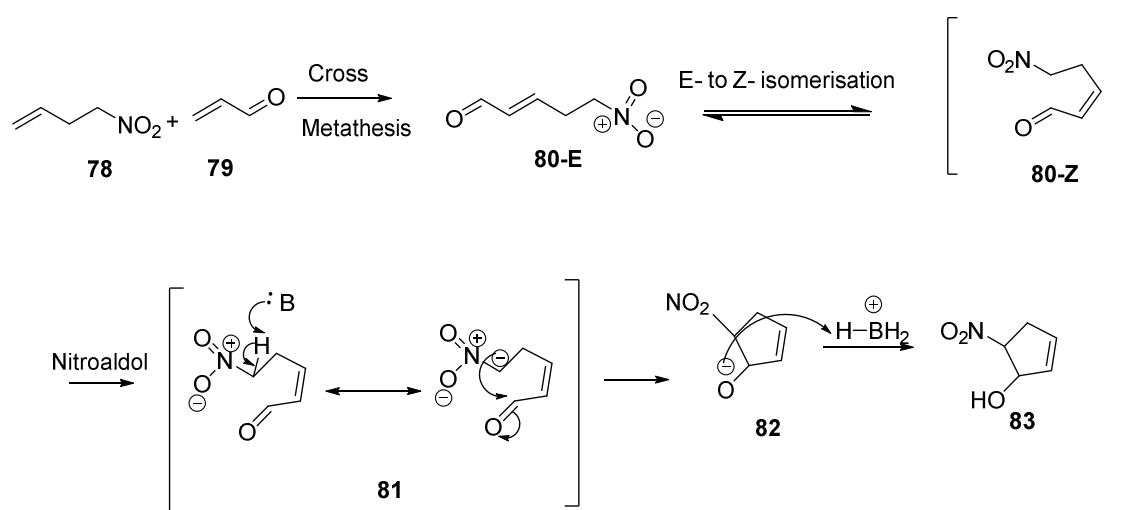

Reagents and Conditions: Various conditions can be investigated to bring about the conversions of Strategy A.

Scheme 20 General Strategy A

2.3.1. Synthesis of Nitroalkenes

In 1872, Victor Meyer and O. Stuber came up with an important synthesis of primary aliphatic nitroalkanes by reacting alkyl halides with a suspension of silver nitrite in anhydrous diethyl ether. Solvents like benzene, hexane and petroleum ether have also been used for reactions that were carried out in the absence of light and in temperature range varying from 0 °C to room temperature.¹¹²

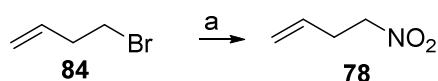

Reagents and conditions: (a) AgNO_2 , Et_2O , reflux with N_2 , 24h, 31%.

Scheme 21 Reaction of 4-bromobutene with AgNO_2

This reaction provides an important synthesis route for substituted and unsubstituted nitroalkanes from primary alkyl halides mainly iodides and bromides. The product for this reaction is generally distilled in order to separate from nitrite ester which is the formed as a result of a side reaction. Generally reactions of alkyl chloride with silver nitrite are too slow and are hence not used for the synthesis of nitroalkanes. Also

synthesis of nitroalkanes, from secondary alkyl halides and substrates having branching is too slow and gives low yield of the nitroparaffin. The problem of nitrite ester formation is dominant in these substrates. Thus Victor Meyer reaction is not considered for the formation of secondary nitroalkanes. Nitrite ester by product formation is enhanced in case of disproportionation of silver nitrite in the presence of heat and light and dehydrohalogenation of the alkyl halide.¹¹²

The transition state in case of Meyer reactions has both SN^1 and SN^2 character. These transition states have a high dependency on solvent system, nature of substrate and the reaction conditions used. The greater the carbocation character of the transition state it is more likely to undergo reaction via SN^1 mechanism and hence form nitrite ester in high yield. The formation of the strong silver halide bond acts as a driving force for Meyer reactions to take place.¹¹²

The reaction of 4-bromobutene (**84**) with silver nitrite in diethyl ether was carried out in order to obtain 4-nitrobutene (**78**) for Strategy A. To optimise the reaction, it was performed under various reaction conditions such as a change in solvent system to (1)water/ether (2)THF (3)DMF and change of reaction conditions such as degassing the reaction mixture for 10 minutes by purging with N_2 gas before 16 hours of reflux was carried out in diethyl ether.¹¹³ (Scheme 21)

Best results with a yield of 31% were obtained when diethyl ether was added to a mixture of 4-bromobutene and $AgNO_2$ and degassed with N_2 for 10 minutes before leaving it for overnight reflux. The yield obtained was very low because of contamination with the nitrite ester side product. The NMR of the sample taken after 1 day showed no expected product peaks. So it was suspected that the product decomposed overnight.

In order to improve yields, avoid the use of expensive reagents like silver nitrite and curb the formation of side products, a shift over to $NaNO_2$ for the conversion of 4-bromobutene to 4-nitrobutene was observed (Scheme 22) . Experimentation with the novel green chemistry introduced by Palmieri by using PEG instead of harmful volatile organic solvents such as *N,N*-dimethylformamide (DMF), dimethyl sulfoxide (DMSO) etc was carried out. PEG has recently been recognised as a novel green solvent with great scope for catalytic processes due to its ready availability, low price, non toxic and

biodegradable nature. The reaction of primary alkyl halides with 1.5-3 equivalent sodium nitrite in PEG at room temperature gave chemoselective nitroalkanes in good yield. According to literature, in this procedure only little quantities (2-6%) of alkyl nitrite were detected.¹¹⁴ No formation of alkyl nitrite was detected by NMR and IR data when the reaction was carried out in the lab proving the reaction to be highly chemoselective.

The reaction involved an initial stirring of the NaNO₂ and the PEG for 3 hours followed by the addition of the bromide and subsequent stirring for 24 hours. The product was extracted with cyclohexane which was stirred with the reaction mixture for 5 minutes and decanted. This process was repeated thrice.¹¹⁴

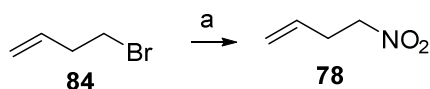

Reagents and conditions: (a) NaNO₂, PEG400, rt, 3h, 57%.

Scheme 22 Reaction of 4-bromobutene with NaNO₂

Due to the high viscosity of PEG, a liquid-liquid extraction couldn't be carried out and we needed to use simple decanting in order to separate the two layers. In spite of careful decantation, PEG impurity was detected in the product. An attempt was made to improve the extraction procedure in order to maximise yield and minimise PEG contamination. The extraction of the product using cyclohexane followed by washing the cyclohexane layer with water repetitively in order to remove the remaining PEG in the cyclohexane layer as PEG was found to be quite soluble in water was tried out. Even after repetitive washing with water, the product NMR showed PEG contamination.¹¹⁴

A new method of extraction was tested which involved the precipitation of ether in dry ice followed by decanting the ether layer. Once the reaction was complete, the reaction mixture was cooled in dry ice-acetone bath to precipitate the PEG and extracted with ether (PEG is insoluble in ether).¹¹⁵ Though, this method of extraction solved the problem of PEG contamination it resulted in average yield of 57%. Control experiments were carried out which involved addition of ether to PEG in small portions and checking the precipitation of the PEG using ether alone and no dry ice as a possibility of the product freezing along with the PEG was suspected which could result in the low

yields. But even after adding 500ml of ether to 2ml of PEG, no precipitation was observed without the use of dry ice.

Addition of salts like NaCl and KCl during extraction with ether decreased the yield further to 41% and 30% respectively. No improvement in PEG precipitation was thus observed due to the addition of NaCl or KCl.¹¹⁶

The obtained yield was used for further cross metathesis reaction with acrolein.

2.3.2. Cross Metathesis of nitro compounds

Alkene metathesis has become a widely used carbon-carbon bond forming reaction. The metathesis of substituted nitroalkenes has recently been studied by Graham et al.¹¹⁷ The development of effective catalysts for this purpose and study of the selectivity of this reaction makes it even more suitable for further introduction of various functionalities in this reaction.

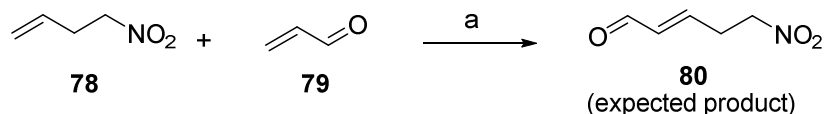

Reagents and conditions: (a) Grubbs II catalyst, acrolein, CH₂Cl₂, reflux, 18h.

Scheme 23 Attempted cross metathesis with Grubbs II catalyst

The procedure involves the treatment of the nitroalkene with required substituted alkene and Grubbs 2nd Generation in boiling dichloromethane to yield the cross metathesis product. Cross metathesis with different groups such as amides, urea functionalised olefins etc have recently been reported.¹¹⁷

Grubbs and his co-workers came up with a useful report on the classification of various functionalised alkenes in their ability to show cross metathesis. Literature precedent of cross metathesis of nitroalkenes with other substituted alkenes showed that nitro compounds do not affect the process of metathesis nor do they deactivate the catalyst involved.¹¹⁷

The mechanism (Figure 13) of olefin metathesis involves redistribution of alkene bonds. In 1971, Herison and Chauvin came up with a proposal for the mechanism which is now widely accepted. It starts with the a [2+2] cycloaddition of an alkene to a metalalkylidene that led to the formation of the metalocyclobutane intermediate which further undergoes a [2+2] cycloreversion to yield ethylene and a substrate loaded metal carbene. The intermediate then reacts with the second alkene in the same fashion and finally releases the product and regenerates the catalyst. This entire cycle is thermodynamically controlled and the driving force for the reaction is the release of the ethylene gas.^{118, 119}

In the case, where two olefins of similar reactivity are made to undergo a cross metathesis, the maximum yield that can be expected is 50 %, as there will be 25% of homo coupling product for each alkene. The percentage yield can be increased to 90% by taking 10 equivalents of one alkene with respect to the other. These reactions become even more complicated because of the stereoselectivity factor. Although mostly the *trans* isomer which is thermodynamically stable is the major product, a mixture of the E and Z isomers can be obtained when the energy gap between the two is negligible. Many methods have been developed to overcome the problems mentioned above and efficiently conjoin two molecules.^{118, 119}

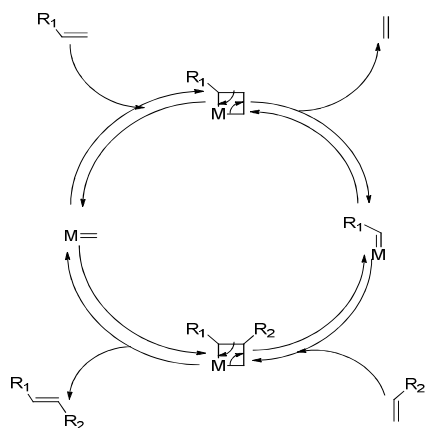

Figure 13 Mechanism of cross metathesis

Grubbs 2nd generation catalyst (Figure 14) was used as a catalyst for the cross metathesis of 4-nitrobutene with acrolein. The Grubbs catalyst act efficiently in

tolerating various functional groups and the new generation Grubbs catalyst have proved to be more stable and active.

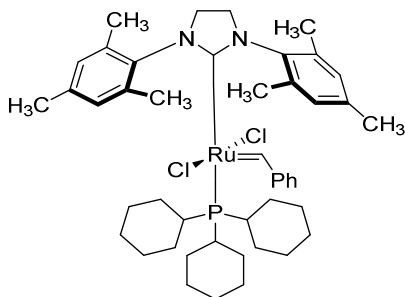

Figure 14 Grubbs II generation catalyst

The Grubbs 2nd generation catalyst was added to a mixture of 4-nitrobutene (**78**) and acrolein (**79**) in dichloromethane and was heated to reflux as according to the procedure given by Xavier.¹¹⁷ The crude residue (**80**) showed NMR peaks of expected cross metathesis product along with impurities. A gel filtration was carried out in order to remove the grubbs catalyst from the reaction mixture. No signs of product were detected following the gel filtration.¹¹⁷ (Scheme 23)

No further investigation was done due to time constraints.

2.3.3. Intramolecular Henry Reaction

The proposed methodology for the formation of the 2,5-dideoxystreptamine analogue from the cross metathesis product involved an intramolecular Henry reaction of (E)-5-nitropent-2-enal (**80**) to yield a 5 membered ring (**83**) followed by addition at the double bond position to yield a 5-membered analogue of 2,5-dideoxystreptamine. It is possible to achieve asymmetry via this procedure (Scheme 24).

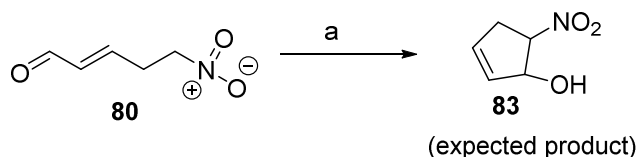

Reagents and conditions: (a) Activity 1 (Brockmann) alumina, 20°C, 48h.

Scheme 24 Possible Future attempts at Intramolecular Nitroaldol of (E)-5-nitropent-2-enal

Ruowei in 1998 established conditions for intramolecular nitroaldol entry to lycoricidine alkaloids. These conditions that involved chelation controlled chair like *transition* state for intramolecular nitroaldol is based on basic alumina promoted procedure for intermolecular Henry nitroaldol used in earlier reports. The conditions involving dissolution of the molecule in dichloromethane and treatment with neutral alumina could be tried out with 5-nitropenten-2-enal which could be followed by addition of different reagents to the double bond to yield the desired 2,5-dideoxystreptamine analogue.¹²⁰

Also, cross metathesis of the 4-nitrobutene with 3-buten-1-al followed by a similar intramolecular nitroaldol could give rise to a 6- membered analogue of the desired molecule.

2.4. General Strategy B

This method (Scheme 25) involved a change of sequences of reactions used in Strategy A. Strategy B started with the Henry nitroaldol reaction between nitroalkenes (**78**) and alkenals (**85**) to obtain nitroalcohols (**86**) which could further undergo ring closing metathesis to give cyclic compound (**87**) containing a double bond that could be substituted with different groups to obtain 2,5-dideoxystreptamine analogues.

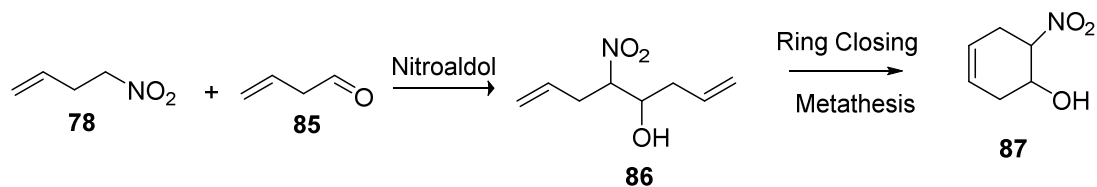

Reagents and Conditions: Various conditions can be investigated to bring about the conversions of Strategy B.

Scheme 25 General Strategy B

2.4.1. Nitro compound synthesised for Strategy B

4-nitrobutene was synthesised from 4-bromobutene using sodium nitrite as mentioned above. The yield of the 4-nitrobutene was suspected to be low due to the high volatility

of the compound. Thus nitroalkenes having higher molecular weight and thus lower volatility were synthesized.

4-Nitro-1-phenylbutene was chosen for this purpose.

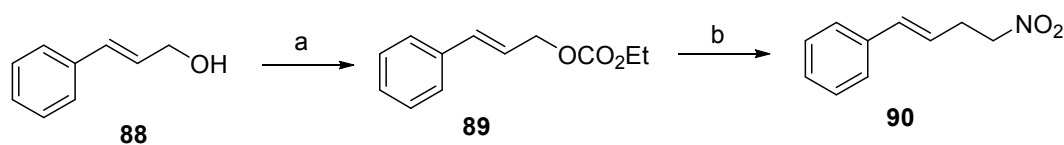

Reagents and conditions: (a) ClCO₂Et, pyridine, 0°C, 16h, 64%; (b) CH₃NO₂, PPh₃, DBA₃Pd₂, rt, 3h, 58%.

Scheme 26 Synthesis of 4-nitro-1-phenylbutene using Pd catalyst route.

Allylation reactions provide a very useful synthetic route for carbon-carbon and carbon-hetero atom bond formation via cationic π -allylpalladium complex (Figure 15). These reactions are very popular because of the high selectivity, nucleophilic compatibility and broad spectrum of π -precursor availability. In this method of synthesis, a desired anion is generated prior to the palladium catalysed step. The use of nitroalkanes and their derivatives with allylic carbonates proceed in the presence of an external base under neutral conditions. Though the nitro group is capable of stabilizing the corresponding carbanion yet only a few examples of inactivated nitroalkanes are known that participate in metal catalysed reactions under such mild conditions.¹²¹

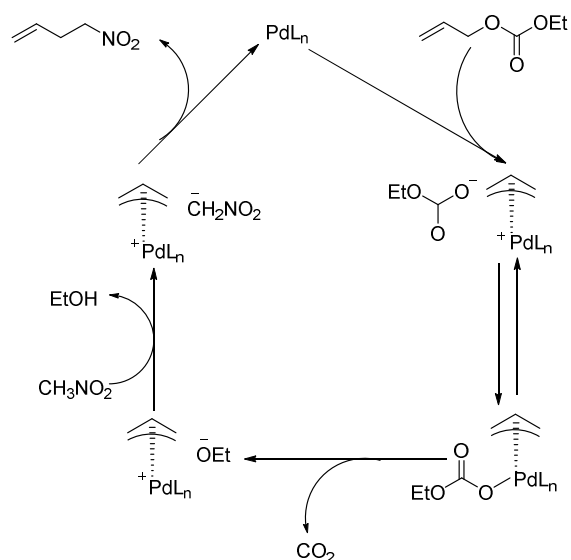

Figure 15 Nitromethylation mechanism via palladium-induced ionisation-fragmentation sequence.

The nitromethylation of the corresponding carbonate takes place through a palladium-induced ionization-fragmentation sequence that led to the generation of equal concentrations of transient metal complex and alkoxide base. The irreversibility of this reaction is attributed to the decarboxylation caused by the evolution of CO_2 . The ethoxide instead of attacking the π -allyl centre directly abstracts a proton from the nitromethane generating a nitronate nucleophile. The soft nucleophile now attacks the η^3 -allyl system.¹²¹

π -allyl intermediate from (Z)-olefins yield complex having anti configuration while (E) olefins give rise to syn isomer (Figure 16). Thus the nucleophilic attack of these compounds yield (Z) and (E) products respectively. However in case of 4-nitro-1-phenylbutene, E product is generated regardless of the stereochemistry of the corresponding carbonate. The reason for this might be attributed to the faster π - σ - π conversion between syn and anti complex as compared to the nitronate attack. The preservation of olefin-aromatic conjugation is responsible for the regiochemical outcome inspite of the lack of a directing heteroatom in case of the nitroalkene in discussion.¹²¹

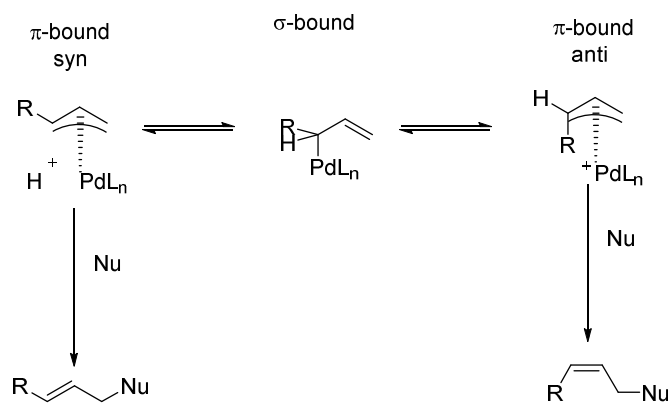

Figure 16 (Z)-olefins yields anti configuration complex while (E)-olefins give rise to stable syn isomer.

Ethyl chloroformate was added drop wise to a solution of cinnamyl alcohol (**88**) in pyridine maintained at 0 °C followed by stirring at room temperature for 16 hours to obtain cinnamyl ethyl carbonate (**89**) in 64% yield. The yield obtained was lower than the value reported in literature. The reaction mixture on work up gave a mixture of the starting alcohol and the carbonate. Variations in the reaction condition by adding extra equivalent of ethylchloroformate, addition of DMAP and monitoring the reaction longer by TLC were not helpful in making the reaction go to completion. The cinnamyl ethyl carbonate was separated from the starting material by flash chromatography. Further reaction of the carbonate with nitromethane in the presence of DBA_3Pd_2 and PPh_3 was carried out to give the corresponding 4-nitro-1-phenylbutene (**90**) in 57% yield as compared to the 71% yield reported in literature. The *trans* stereochemistry of the C=C was verified by the J value which was found to be greater than 15 Hz. (Scheme 26)¹²¹

Bisallylated product formation often takes place in reactions involving addition of diprotic soft nucleophiles to π -allylpalladium complexes. However, no bisallylated product formation takes place in the above case. Though monoallylated nitroalkenes are prone to secondary allylation as α -substituted nitrocompounds are more acidic as compared to nitromethane, no bisallyl product is observed. This is due to the fact that nitromethylation takes place via solvolysis and hence nucleophiles that have less concentration are suppressed.¹²¹

2.4.2. Intermolecular Henry Reaction

Two different types of Henry reaction with different reagents were tried out.

Benzaldehyde was chosen as the aldehyde for the trial Henry reaction.

- (i) 4-nitrobutene was made to undergo a nitroaldol reaction with benzaldehyde and KOH under solventless conditions.

Traditional Henry nitroaldol reactions involve base catalysed condensation of an aldehyde with a nitroalkane to yield the required nitroalcohol. But this method suffers from various disadvantages like slow reaction rate, low yields and waste production. Also this nitroalcohol forming reaction could be made more environment friendly by avoiding the use of solvent.¹²²

According to literature, initial trial of Henry reaction of aldehyde with nitroalkane without any solvent in the presence of catalytical amount of base like KOH proved to be unsuccessful due to the base catalysed elimination of water that led to the formation of nitroolefins which polymerized to yield a complex product. The addition of surfactant like PEG presumably acts like a phase transfer catalyst in the conventional manner and compensate for lack of solvation. No work up was required for this reaction and it had a 100% overall throughput according to the literature.¹²²

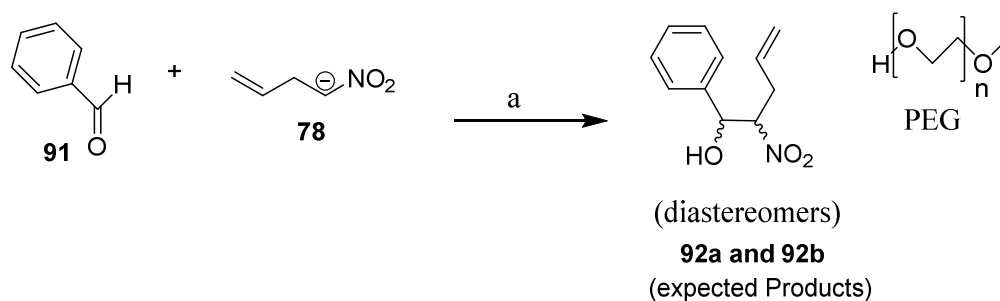

Reagents and conditions: (a) KOH, PEG400, 60°C 2h.

Scheme 27 Attempted intermolecular Henry reaction under KOH, solventless conditions

Reaction of benzaldehyde (**91**) with a mixture of 4-nitrobutene (**78**), KOH and PEG400 at 60 °C, monitored for a day by TLC failed to show nitroaldol and NMR showed reactant peaks and no sign of product formation was detected.¹²² (Scheme 27)

(ii) 4-Nitro-1-phenylbutene was made to undergo nitroaldol reaction with triethylamine base (Scheme 28).

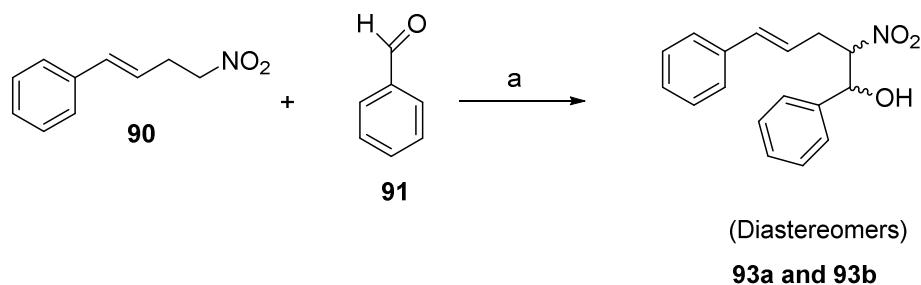

Reagents and conditions: (a) Et₃N, H₂O, rt, 6h, 13%.

Scheme 28 Inter-molecular Henry Reaction with triethylamine base and water.

A chemoselective route towards nitroalcohol was chosen that involved the use of triethyl amine as base and water as solvent.¹²³ Benzaldehyde (**91**) was added to a mixture of 4-nitro-1-phenylbutene (**90**) and triethylamine in water that resulted in the formation of mixture of diastereomers of (E)-2-nitro-1,5-diphenylpent-4-en-1-ol having a yield of 13% (**93a** and **93b**). Though the conditions used for nitroaldol gave unsatisfactory yield both the diastereomers could be distinguished by the NMR peaks and were found to be present in a 1:6 ratio. An observable difference was noted between the two diastereomers in their NMR values of $\text{CH}_a\text{H}_b\text{-CH-NO}_2$, $\text{CH}_a\text{H}_b\text{-CH-NO}_2$, $\text{CH}_a\text{H}_b\text{-CH-NO}_2$, Ph-CH-OH , CH=CH-CH_2 , Ph-CH=CH .

Table 1 Comparison of chemical shifts and J values of the two diastereomers of (E)-2-nitro-1,5-diphenylpent-4-en-1-ol

S.No.	PROTON	DIASTEREOMER	Δ	J
1	$\text{CH}_a\text{H}_b\text{-CH-NO}_2$	A	2.74	M
		B	2.28	M
2	$\text{CH}_a\text{H}_b\text{-CH-NO}_2$	A	2.97	dd, $J=11.6, 21.1$ Hz
		B	2.62	M
3	$\text{CH}_a\text{H}_b\text{-CH-NO}_2$	A	4.69	M
		B	4.75	ddd, $J=3.9, 9.0, 10.2$ 1Hz
4	Ph- CH-OH	A	5.20	d, $J=5.1$ Hz
		B	5.04	d, $J=8.9$ Hz
5	CH=CH-CH_2	A	5.96	ddd, $J=6.6, 7.9, 15.7$ Hz
		B	5.86	ddd, $J=6.4, 8.1, 15.7$ Hz
6	Ph- CH=CH	A	6.37	d, $J=15.7$ Hz
		B	6.28	d, $J=15.7$ Hz

NOTE: Diastereomers A and B refer to 93a and 93b.

2.4.3. Ring Closing Metathesis

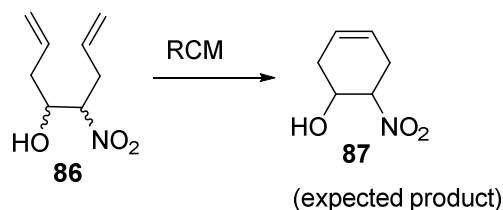

Reagents and conditions: Suitable ring closing catalyst can be investigated for the above conversion.

Scheme 29 Future attempts at ring closing metathesis of 5-nitroocta-1, 7-dien-4-ol

Ring Closing Metathesis can be used to synthesize cyclic alkenes. Whether these alkenes are E/Z depends on the strain in the molecule. The reaction proceeds in the forward direction due to the loss of ethylene molecule. Due to the research on a number of catalysts that are not only tolerant to various functional groups but also active towards a number of alkene substrates makes this method a very popular method for

macrocyclizations. RCM proceeds via metalloacyclobutane and metal-carbene intermediate. Mo and Ru catalysts are generally used for metathesis. Ru is more favoured due to its tolerance to a wide variety of functional groups as compared to Mo. On carrying out a Henry nitroaldol reaction between 4-nitrobutene (**78**) and 4-butenal (**85**), 5-nitroocta-1,7-dien-4-ol (**86**) can be synthesized which after ring closing metathesis can yield (**87**). (Scheme 29)

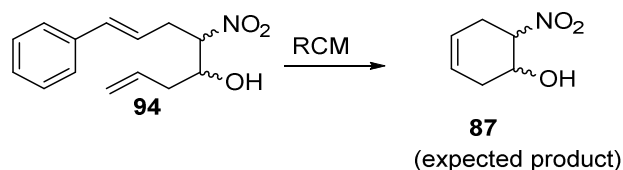

Reagents and conditions: Suitable ring closing catalyst can be investigated for the above conversion.

Scheme 30 Future attempts at ring closing metathesis of (E)-5-nitro-8-phenylocta-1, 7-dien-4-ol.

On similar lines a Henry reaction between 4-Nitro-1-phenylbutene (**90**) and 4-butenal (**85**) would yield (E)-5-nitro-8-phenylocta-1, 7-dien-4-ol (**94**) which subsequently on ring closure give (**87**). (Scheme 30)

Suitable catalyst and conditions should be investigated for the ring closing of compounds that is tolerant to both nitro and hydroxyl group.

2.5. General Strategy C

This strategy involves the formations of nitroalcohols by tin (II) chloride mediated reactions between alkenals for eg. crotonaldehyde and bromonitromethane to yield nitroalcohol (**95**). This was followed by alkylation (**97**) with alkenes at carbon α to the nitro group using Seebach's conditions¹²⁵ and was concluded by ring closing metathesis which yielded cyclic nitroalcohol (**98**) compounds. The double bond in these compounds could suitably be substituted to yield 2,5-dideoxysteptamine analogues. (Scheme 31)

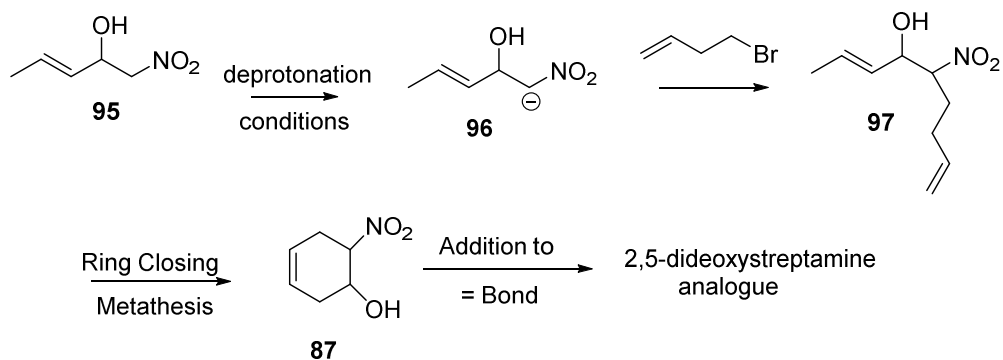

Reagents and Conditions: Various conditions can be investigated to bring about the conversions of Strategy C.

Scheme 31 General Strategy C

2.5.1. Tin (II) chloride mediated nitroalcohol formation

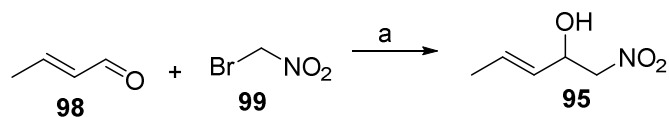

Reagents and conditions: (a) SnCl_2 , $(\text{C}_2\text{H}_5)_2\text{O}$, rt, 7h, 68%.

Scheme 32 Synthesis of (E)-1-nitropent-3-en-2-ol using tin(II) chloride reaction

An alternative route (Scheme 32) to β -nitroalcohol was used for the synthesis of 1-nitropent-3-en-2-ol. Crotonaldehyde (**98**) was reacted with bromonitromethane (**99**) in the presence of tin (II) chloride to yield the corresponding nitroalcohol-1-nitropent-3-en-2-ol (**95**) in 68% yield. Bromonitromethane shows C1 chemistry due to the presence of one carbon in the molecule. In chemical synthesis, the use of bromonitromethane has two advantages – (a) the nitro group of the β -nitroalcohol generated can be easily reduced to the corresponding amino group (b) α -hydrogen atoms next to the nitro group are highly acidic and hence can be useful for C-C bond formation by deprotonation and alkylation reaction. The reaction mediated by tin (II) chloride is known to have relatively short reaction times, low cost of starting materials and easy handling.

The mechanism (Scheme 33) for this reaction has not yet been looked into, yet a Reformatsky-type mechanism has been suggested for this reaction in literature.¹²⁴

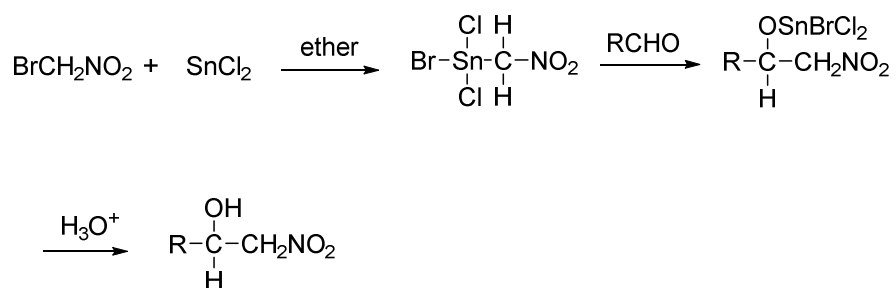

Scheme 33 Reformatsky-type mechanism for preparation of 1-nitropent-3-en-2-ol

Using similar reaction conditions, reactions were carried out between crotonaldehyde (**98**) and benzyl bromide (**100**) and benzyl bromide (**100**) and bromonitromethane (**99**) were carried out in the presence of tin (II) chloride. None of the two reactions showed any proof of success and expected product could not be obtained. (Scheme 34)

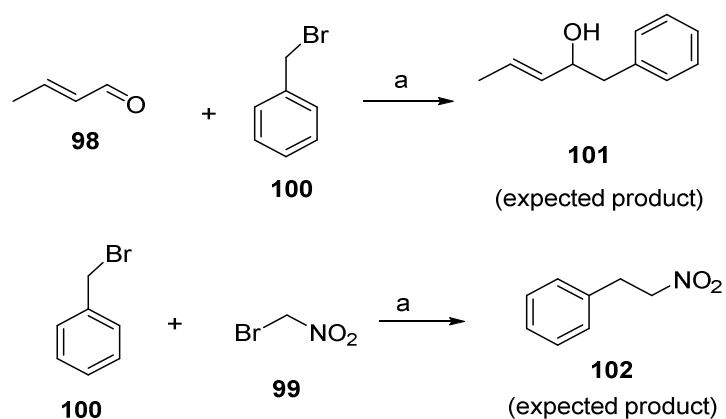

Reagents and conditions: (a) SnCl_2 , $(\text{C}_2\text{H}_5)_2\text{O}$, rt, 7h .

Scheme 34 Attempted tin (II) chloride reaction between crotonaldehyde and benzyl bromide, benzyl bromide and bromonitromethane.

2.5.2. Seebach's conditions for deprotonation followed by reaction with benzyl bromide

An attempt (Scheme 35) to deprotonate 1-nitropent-3-en-2-ol at C1 position was tried out using Seebach's deprotonation techniques with a slight change of using TMEDA instead of HMPT.

In a cold solution (-78°C) of lithium diisopropylamide which is an organic base and is frequently used for deprotonation, TMEDA was added. There was a subsequent addition of the nitroaldol (**95**) in the cold solution followed by stirring for 1 hour. This solution was thereafter cooled to -100°C and benzyl bromide (**100**) was added and the reaction mixture was monitored for 2 days. Expected alkylation (**104**) by benzyl bromide wasn't detected by NMR.¹²⁵

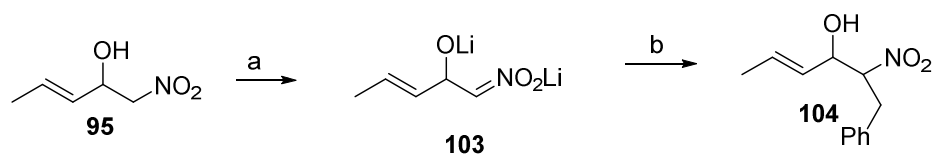

Reagents and conditions: (a) LDA, TMEDA, -78°C , 1h; (b) PhCH_2Br , -100°C , 2 days.

Scheme 35 Attempted deprotonation using Seebach's technique.

2.5.3. Ring Closing Metathesis

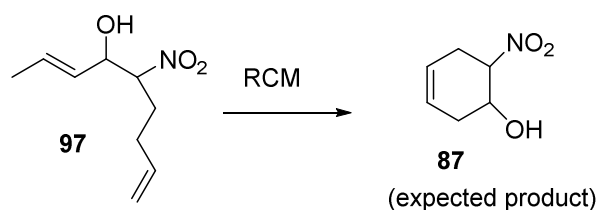

Reagents and conditions: Suitable ring closing catalyst can be investigated for the above conversion.

Scheme 36 Future attempts at ring closing metathesis of **97**.

If conditions can be set appropriately for the deprotonation of 1-nitropent-3-en-2-ol (**95**) at C1 position followed by alkylation with 4-bromobutene (**84**), we could obtain 5-

nitronona-2,8-dien-4-ol (**97**). This obtained intermediate could undergo ring closing metatheses to yield a six member ring (**87**). Addition of substituents to the double bond of the 3-methyl-6-nitrocyclohex-3-enol intermediate followed by reduction of the NO₂ group to NH₂ or vice versa in the order appropriate can yield the desired 2,5-dideoxystreptamine analogue. (Scheme 36)¹²⁵

2.6. Attempted Dehydration of 4-nitro-1-phenylbutene and (E)-2-nitro-1,5-diphenylpent-4-en-1-ol

(i) Dehydration of -nitropent-3-en-2-ol

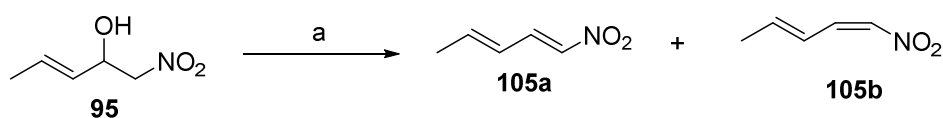

Reagents and conditions: (a) MsCl, Et₃N, CH₂Cl₂, 0°C, under N₂, 15 mins.

Scheme 37 Attempted dehydration of 1-nitropent-3-en-2-ol

During our synthesis of various nitro compounds for our recent study towards synthesis of 2,5-dideoxystreptamine analogue, an attempt was made to synthesize nitro-olefins by the dehydration of the nitroalcohols synthesized. Various reagents have been used for dehydration before such as phosphorous pentoxide and phthalic anhydride etc. These methods require the acetylation of the hydroxyl followed by elimination using sodium acetate. Due to the severe conditions (120 °C, 5hours) required for these reactions, they are generally found to be low yielding. A better method for dehydration was presented by Murry. This method involved converting the alcohol into a better leaving group which was brought into affect by treating the nitroalcohol with 1 equivalent of methanesulfonyl chloride in dichloromethane at 0 °C. This was followed by addition of triethylamine and stirring for 15 minutes at 0 °C.¹²⁶

Peaks for dehydration of 1-nitropent-3-en-2-ol (**95**) were too complex to distinguish the (E, E) and (E, Z) isomers peaks (**105a** and **105b**). The mesylate was observed on NMR. (Scheme 37)

(ii) Dehydration of (E)-2-nitro-1, 5-diphenylpent-4-en-1-ol

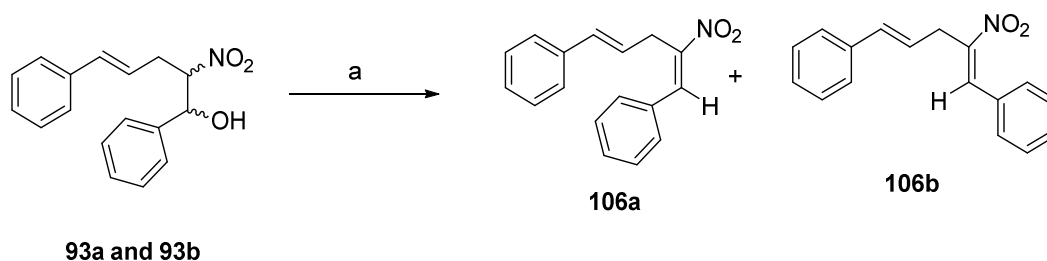

Reagents and conditions: (a) MsCl, Et₃N, CH₂Cl₂, 0°C, under N₂, 15 mins.

Scheme 38 Attempted dehydration of (E)-2-nitro-1,5-diphenylpent-4-en-1-ol

Similar reaction was carried out for (E)-2-nitro-1, 5-diphenylpent-4-en-1-ol (**93**). Peaks for (E, E) and (E, Z) did not grow substantially in order to interpret the NMR (**106a** and **106b**). (Scheme 38)

2.7. Conclusion and Future works

Various novel strategies were developed for the synthesis of 2,5-dideoxystreptamine from nitro compounds. Due to the low yields of the epoxide route to 2,5-dideoxystreptamine, a better and easier method for synthesis of a library of compounds mimicking the biologically significant 2-DOS was sought.

The route towards formation of the desired molecule was carried out using bisepoxidation followed by ring opening using hydrazine and reductive cleavage in the presence of Pd. This method was abandoned due to the low yields of the *cis*-bisepoxide intermediate, which could not be improved much by using different reaction schemes.

Three strategies, with variation in the sequence of reactions performed, were used to synthesize 2,5-dideoxystreptamine from nitro compounds. Ground work has been performed for these initial ideas which could lead to the formation of the molecule by using appropriate reaction conditions.

STRATEGY A: 4-nitrobutene (**78**) synthesized from 4-bromobutene (**84**) was made to undergo a cross metathesis reaction with acrolein (**79**). Suitable reaction conditions could not be developed for a successful metathesis. This strategy presents a good scope for the future. If the conditions of cross metathesis can be optimised, a subsequent intramolecular nitroaldol between the nitro and the aldehyde groups in the molecule (**80**) would yield a cyclic nitroaldol (**83**) with a double bond that could be substituted appropriately to generate a library of 2,5-dideoxystreptamine analogues. Also the number of carbon atoms in the ring can be controlled by using different nitroalkenes and aldehydes. (Scheme 39)

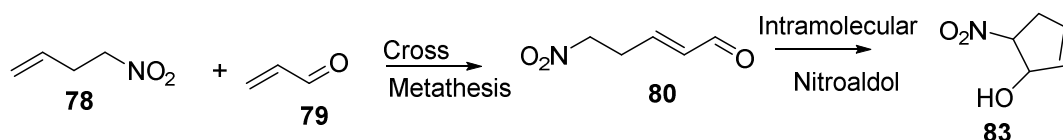

Reagents and Conditions: Various conditions can be investigated to bring about the conversions of Strategy A.

Scheme 39 Strategy A

STRATEGY B: The second strategy involves a Henry nitroaldol reaction between 4-nitrobutene (**78**) and 4-butenal (**85**) to yield **86**, followed by ring closing metathesis to yield cyclic nitroalcohol **87** containing a double bond that could be substituted accordingly. (Scheme 40)

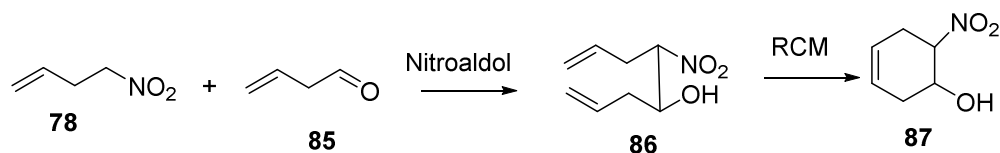

Reagents and Conditions: Various conditions can be investigated to bring about the conversions of Strategy B.

Scheme 40 Strategy B

STRATEGY C: This strategy employs the tin (II) chloride reaction between crotonaldehyde (**98**) and bromonitromethane (**99**) to give the corresponding β -

nitroalcohol (**95**) which could further be deprotonated and alkylated at the carbon α to the nitro group with an alkene (**97**). Further ring closing metathesis would generate a double bonded cyclic nitroalcohol (**87**) that could suitably be substituted. Standardisation of alkylation followed by ring closing metathesis can be worked on in the future to give 2,5-dideoxystreptamine in good yields. (Scheme 41)

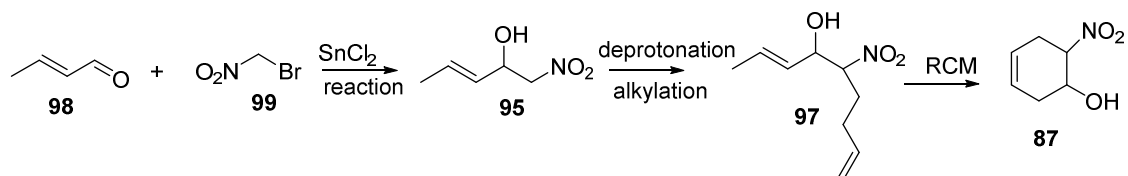

Reagents and Conditions: Various conditions can be investigated to bring about the conversions of Strategy C.

Scheme 41 Strategy C

CHAPETR 3. EXPERIMENTAL

3.1. General

Unless otherwise stated all reactions were carried out in dried glassware. Reactions were monitored by Thin Layer Chromatography (TLC) on Merck silica gel 60 F₂₅₄ plates. Plates were visualized under ultra violet lamp and stained using agents like KMnO₄, iodine, anisaldehyde. Column chromatography was carried out on Silica Gel 60 Merck (particle size 40-63 μm). ¹H NMR spectra were obtained using Bruker 300 MHz or Bruker 400 MHz spectrometer. Data has been reported as chemical shifts using the parts per million scale using TMS as internal standard. Multiplicity has been abbreviated as follows (br-broad, s- singlet, d- doublet, dd-double doublet, t-triplet, m-multiplet and various other combinations of coupling) and coupling constants *J* have been reported in Hertz. ¹³C NMR spectra were obtained using Bruker 75 MHz or Bruker 100 MHz spectrometer and were reported in ppm units. Infrared spectra were recorded on potassium bromide discs using a Genesis series FTIR spectrometer. The electrospray mass spectra were recorded on a Micromass 2000 instrument. High resolution mass spectra were acquired using a Thermo Finnigan MAT95XP spectrometer. All mass spectrometry results are reported as *m/z*.

3.2. Synthesis of 2, 5-dideoxystreptamine using Bisepoxide method

3.2.1. 1, 4-Diepoxycyclohexane by Direct Bisepoxidation

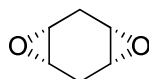

60a

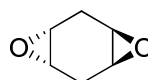

60b

Method A

mCPBA (3.12 g, 18 mmol) in dichloromethane (15 ml) was stirred and cooled to 0 °C. A solution of 1,4-cyclohexadiene (0.78 ml, 8 mmol) in dichloromethane (2 ml) was added to this mCPBA solution and the reaction was stirred for 5 hours at 0 °C and then at room temperature overnight. TLC showed two spots that were quite well separated. The suspension was filtered and the white solid was washed with dichloromethane. The filtrates were combined and stirred with aqueous sodium sulfite (20% w/v, 25 ml) for 2

hours. The organic phase was separated and the aqueous layer was washed with dichloromethane (6 × 20 ml). The combined dichloromethane extracts were stirred with an aqueous solution of NaOH (1M, 20 ml) for 2 hours to remove any traces of excess mCPBA. The organic layers were combined, dried over MgSO₄ and the solvent removed to afford an oily residue. The crude product was dissolved in warm water and filtered. The aqueous layer was extracted with ether (10 × 10 ml) to produce a white solid. Spectroscopic Characterisation confirmed it to be **60b** (0.13 g, 14%). Extraction of the aqueous layer into dichloromethane (6 × 10 ml) afforded a brown solid. Spectroscopic characterisation confirmed it to be **60a** (0.04 g, 5%).¹⁰¹

60a: R_f (ether) 0.34; IR (KBr thin film) $\nu_{\max}/\text{cm}^{-1}$ 1263 s, 837, 940 (epoxide); ¹H NMR δ (CDCl₃, 400 MHz) 2.19 (2H, d, $J=17.1$ Hz, CH₂H_b), 2.69 (2H, d, $J=17.1$ Hz, CH_aH_b), 3.01 (4H, s, HCO); ¹³C NMR δ (CDCl₃, 100 MHz) 23.81 (CH₂), 49.47 (HCO); m/z (CI +ve) found 135 (M+Na)⁺ and 247 (M+M+Na)⁺ required 135.

60b: R_f (ether) 0.75; IR (KBr thin film) $\nu_{\max}/\text{cm}^{-1}$ 1465-1382, 950-904 (epoxide); ¹H NMR δ (CDCl₃, 400 MHz) 2.23 (4H, s, CH₂), 3.02 (4H, s, HCO); ¹³C NMR δ (CDCl₃, 100 MHz) 24.02 (CH₂), 49.3 (HCO); m/z (CI +ve) found 247 (M+M+Na)⁺ required 135.

Method B

A solution of 1,4-cyclohexadiene (0.78 ml, 8 mmol) in dichloromethane (2 ml) was added to a solution of mCPBA (3.00 g, 17.4 mmol) in dichloromethane (14.5 ml) at -30 °C for 6 hours and then maintained at room temperature for the next 6 days. The reaction mixture was filtered and washed with dichloromethane and the solvent was concentrated *in vacuo*. The crude product was passed through a column in ether to obtain **60a** (0.31 g, 35%) and **60b** (0.37 g, 42%) respectively.

Method C

1, 4-cyclohexadiene (0.5 ml, 5.3 mmol), mCPBA (2.00 g, 11.6 mmol) and K₂HPO₄ (0.90 g, 5.1 mmol) were stirred in dichloromethane (45 ml) and water (0.5 ml) for 18 hours. The solution was washed with saturated NaHCO₃ (20 × 3 ml), 5% Na₂SO₃ (3 × 20 ml), water (3 × 20 ml) and brine (3 × 20 ml) and was dried over MgSO₄. The solution was dried off under atmospheric pressure and gave the bisepoxides (**60a: 60b**) in a ratio

of 1:4. The crude product was passed through a column in ether to yield **60a** (0.05 g, 8%) and **60b** (0.20 g, 34%). The products were characterized as given above.

3.2.2. *Trans*-4-Hydroxy-5-bromocyclohexene

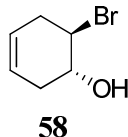

To a solution of 1,4-cyclohexadiene (0.78 ml, 8 mmol) in dioxane (0.31 ml) and H₂O (3.5 ml), was added *N*-bromosuccinimide (1.38 g, 8 mmol) portionwise. The mixture was stirred at room temperature for 3 hours. The crude product was washed with saturated aqueous NaHCO₃ (3 × 10 ml) and saturated aqueous NaCl (3 × 10 ml). The organic layer was dried over MgSO₄ and the solvent was removed under reduced pressure to afford **58** as colourless oil (0.85 g, 61%).¹⁰¹

58: R_f (ether) 0.34; IR (KBr thin film) $\nu_{\max}/\text{cm}^{-1}$ 3274-3264 s (OH), 3031 m (C=CH), 1653 w (C=C), 666 s (C-Br); ¹H NMR δ (CDCl₃, 400 MHz) 2.12-2.95 (4H, m, CH₂), 3.63-3.84 (1H, m, CHBr), 4.00-4.23 (1H, m, CHOH), 5.37-5.59 (2H, m, CH=CH); ¹³C NMR δ (CDCl₃, 100 MHz) 32.85 (CH₂), 36.27 (CH₂), 57.56 (CHBr), 71.52 (CHOH), 124.68 (CH=CH), 124.95 (CH=CH); *m/z* (CI -ve) found 353, 355 (M-M-H)⁺ sample dimerised required (M-H)⁺ 175,177 and (M+Cl)⁻ 211, 213.

3.2.3. 4,5 Epoxy-*trans*-2-bromocyclohexanol

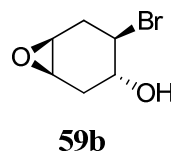
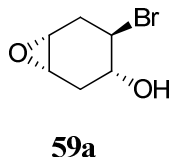

Trans-4-hydroxy-5-bromocyclohexene (**58**) (0.85 g, 4.78 mmol) was added to a solution of mCPBA (0.83 g, 4.78 mmol) in dichloromethane (6.8 ml). The reaction was stirred in the dark at room temperature for 24 hours. On completion the suspension was filtered, washed with dichloromethane and the solvent removed under reduced pressure. The crude product, which gave an a 3:1 mixture in favour of the desired isomer **59a** by NMR, was obtained as a colourless oil (0.38 g, 40%) and taken through to the next reaction without separation of the diastereoisomers.¹⁰¹

59a: R_f (ether) 0.51; **IR** (KBr thin film) $\nu_{\max}/\text{cm}^{-1}$ 3500-3350s (OH), 1259 m, 801 m and 953 (epoxide), 1065s (C-O), 631 w (C-Br); **$^1\text{H NMR}$** δ (CDCl_3 , 400 MHz) 2.11-2.97 (4H, m, CH_2), 3.29-3.34 (2H, m, epoxide H), 3.78-4.19 (2H, m, CHBr , CHOH); **$^{13}\text{C NMR}$** δ (CDCl_3 , 100 MHz), 30.21 (CH_2), 33.92 (CH_2), 51.39, 51.65 and 60.00 (CHBr and HCO), 70.07 (CHOH); m/z (CI +ve) found 384, 385 (M-M-H)⁺ sample dimerised required 193, 195 (M+H)⁺ or (M+Na)⁺ 215, 217.

59b: R_f (ether) 0.75; **$^1\text{H NMR}$** δ (CDCl_3 , 400 MHz) 1.75-1.92 (2H, m, CH_2), 2.52 -2.85 (2H, m, CH_2), 3.14-3.27 (2H, m, epoxide H), 3.78-3.94 (2H, m, CHBr , CHOH); **$^{13}\text{C NMR}$** δ (CDCl_3 , 100 MHz) 32.93 (CH_2), 35.78 (CH_2), 51.53, 54.29 and 56.12 (CHBr and HCO), 69.53 (CHOH).

3.2.4. 1, 4-Diepoxycyclohexane

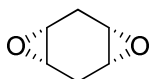

60a

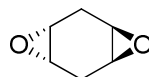

60b

To a solution of 4, 5-epoxy-*trans*-2-bromocyclohexanol (**59**) (0.38 g, 1.98 mmol) in MeOH (4 ml), was added K_2CO_3 (0.5479g, 3.96mmol). The reaction was stirred for 3 hours at room temperature. On completion the reaction mixture was filtered and the crude product isolated by column chromatography in ether. **60a** was obtained as a brown solid (0.09 g, 43%) and **60b** as a white solid (0.02 g, 12%).¹⁰¹

Characterisation same as mentioned in 3.2.1.

3.2.5. 1, 4-cyclohexadiene monoepoxide

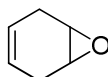

77

1, 4-cyclohexadiene (0.5 ml, 5.3 mmol), mCPBA (0.88 g, 5.1 mmol) and K_2HPO_4 (0.90 g, 5.2 mmol) were stirred in dichloromethane (37.5 ml) and water (0.25 ml) for 18 hours. The solution was washed with saturated NaHCO_3 (3 \times 10 ml), 5% Na_2SO_3 (3 \times 10 ml), water (3 \times 10 ml), and brine (3 \times 10 ml), and was dried over MgSO_4 . The solution was

dried off and purified using a silica gel column in 2:1 Hexane-EtOAc solvent system to yield the monoepoxide as a colourless liquid (0.31 g, 62%).¹¹¹

77: R_f (2:1 Hexane: EtOAc) 0.67; **IR** (KBr thin film) $\nu_{\max}/\text{cm}^{-1}$ 1725 m, 1426 m, 1230 m (epoxide), 1020 m (C-O); **$^1\text{H NMR}$** δ (CDCl_3 , 400 MHz) 2.44 (2H, d, $J=13.5$ Hz, CH_aH_b), 2.56 (2H, d, $J=13.8$ Hz, CH_aH_b), 3.24 (2H, s, HCO), 5.43 (2H, s, $\text{CH}=\text{CH}$); **$^{13}\text{C NMR}$** δ (CDCl_3 , 100 MHz) 24.86 (CH_aH_b), 50.80 (HCO), 121.37 ($\text{CH}=\text{CH}$); m/z (CI +ve) found 97 ($\text{M}+\text{H}$)⁺ required 97.

3.2.6. 7, 8-Diazabicyclo [3.2.1] octane-4, 6-diol

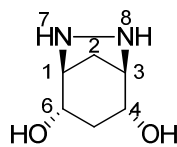

61

Cis-1, 4-diepoxy cyclohexane **60a** (0.09 g, 0.85 mmol) was dissolved in dry ethanol (5 ml) and hydrazine monohydrate (0.05 ml, 1 mmol) was added to it. The solution was refluxed under nitrogen for 16 hours. The mixture was then filtered, washed with ether (3 \times 5 ml), dried under vacuum to obtain **61** (0.09 g, 70%) as a white precipitate.¹⁰²

61: **$^1\text{H NMR}$** δ (D_2O , 400 MHz) 1.53 (1H, dt, $J=5.1, 13.3$ Hz, H5_{eq}), 1.62 (1H, d, $J=6.7$ Hz, H2_{ax}), 2.00 (1H, dt, $J=5.1$ and 6.7 Hz, H2_{eq}), 2.71 (1H, d, $J=13.3$ Hz, H5_{ax}), 3.50 (2H, t, $J=5.1$ Hz, $\text{H1}, 3$), 3.87 (2H, t, $J=5.1$ Hz, $\text{H4}, 6$); **$^{13}\text{C NMR}$** δ (D_2O , 100 MHz) 27.34 (C2), 33.55 (C5), 58.73 (C1, 3), 69.22 (C4, 6).

3.3. Novel Synthesis of 2,5-dideoxystreptamine from nitro compounds – Strategy A

3.3.1. 4-nitrobutene

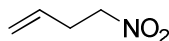

78

Method A

Anhydrous diethyl ether (2 ml) was added to a mixture of AgNO_2 (0.48 g, 3.11 mmol) and 4-bromobutene (0.1 ml, 0.98 mmol) that was degassed by purging with N_2 gas for

10 minutes. The mixture was heated under reflux under nitrogen atmosphere overnight. The mixture was filtered and concentrated under reduced pressure and purified by passing through silica column in 1:1 Hexane-EtOAc solvent system to obtain **78** (0.03 g, 31%) as a yellow oil.¹¹³

NOTE: Compound 78 was not cited in ref 113 but their method of preparation was as cited.

78: R_f (1:1 Hexane: EtOAc) 0.58; **IR** (KBr thin film) $\nu_{\max}/\text{cm}^{-1}$ 1548 s (N-O), 1378 m (N-O), 1648 w (C=C); **¹H NMR** δ (CDCl₃, 400 MHz) 5.74 (1H, ddt, $J=6.4, 10.0, 16.58$ Hz, CH_aH_b=CH), 5.05-5.18 (2H, m, CH_aH_b=CH), 4.35 (2H, t, $J=6.9$ Hz, CH₂NO₂), 2.66-2.81 (2H, m, C=C-CH₂); **¹³C NMR** δ (CDCl₃, 100 MHz) 131.73 (CH_aH_b=CH), 118.92 (CH_aH_b=CH), 74.57 (CH₂-NO₂), 31.07 (C=C-CH₂); m/z Compound did not site an interpretable mass spec.

NOTE: The reaction was carried out in (1) water/ ether (2) THF (3) DMF using the same procedure but NMR product peaks showed 4-nitrobutene formation only in the above case.

Method B

NaNO₂ (1.39 g, 20.1mmol) was stirred in PEG400 (2 ml) for 3 hours at room temperature. 4-Bromobutene (0.7 ml, 6.9 mmol) was added and the reaction mixture was subsequently stirred for the next 24 hours. Diethyl ether (10 ml) was added to the reaction mixture and stirred with it in a dry ice bath until the PEG precipitated. The ether layer was decanted and kept in a flask. This procedure was repeated four times (4 × 10 ml). The ether was removed under reduced pressure and passed through a column in 60:40 hexane-EtOAc solvent system to yield **78** (0.40 g, 57 %) as a yellow oil.¹¹⁴

The characterization data is in agreement with data presented in 3.3.1 Method A.

NOTE: Compound 78 was not cited in ref 114 but their method of preparation was as cited.

3.3.2. 6-nitrohexa-1, 3-diene

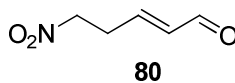

Attempted Cross Methathesis of acrolein with 4-nitrobutene

Grubbs 2nd generation catalyst (0.02 g, 0.03 mmol) was added to a stirred solution of 4-nitrobutene (**78**) (0.10 g, 0.99 mmol) and acrolein (0.26 ml, 3.97 mmol) in dichloromethane (10 ml) and the reaction was heated to reflux. The reaction was maintained at this temperature for 18 hours and cooled to room temperature before it was concentrated *in vacuo*. A silica gel filtration was performed to obtain purified product.¹¹⁷

NOTE: Compound 80 was not cited in ref 117 but their method of preparation was as cited.

NMR of the crude product showed a number of alkene peaks along with impurities. Product peaks were not detected after performing silica gel filtration.

3.4. Strategy B

3.4.1(a). Cinnamyl Ethyl Carbonate

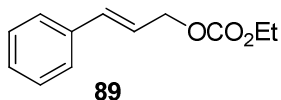

To a flask purged with N₂ gas dry pyridine (7 ml) was added. Cinnamyl alcohol (0.40 g, 2.97 mmol) was added to this flask and the solution was cooled to 0 °C in an ice-water bath followed by addition of cold ethyl chloroformate (0.35 ml, 4.21 mmol) dropwise over 5 minutes. On completion of the addition, the ice water bath was removed. After 16 hours, the reaction was quenched by diluting with ether which was subsequently followed up by extraction with saturated NH₄Cl (3 × 5ml), 1N HCl (3 × 5ml) and saturated NaHCO₃ (3 × 5ml). The organic layer was collected and dried over MgSO₄ and concentrated under reduced pressure. The residue was then purified using column chromatography in 85:15 Hexane-EtOAc solvent system to give **89** (0.40 g, 64%) as a clear oil.¹²¹

89: R_f (85:15 Hexane: EtOAc) 0.54; IR (KBr thin film) $\nu_{\max}/\text{cm}^{-1}$ 2900-3100 m (aromatics), 1739 s (C=O), 1610 m (C=C), 1447-1379 v (C₂H₅), 1248-1050 s (C-O), 967-692 s (C=C); ¹H NMR δ (CDCl₃, 400 MHz) 1.21 (3H, t, *J*=7.2 Hz, CH₃), 4.12 (2H,

q, $J=7.2$ Hz, $\underline{\text{C}}\underline{\text{H}}_2\text{CH}_3$), 4.68 (2H, dd, $J=1.3, 6.5$ Hz, $\underline{\text{C}}\underline{\text{H}}_2\text{OCO}_2\text{Et}$), 6.19 (1H, dt, $J= 6.4, 15.9$ Hz, $\text{CH}=\underline{\text{C}}\text{H}-\text{CH}_2$), 6.58 (1H, br d, $J= 15.9$ Hz, $\text{Ph}-\text{CH}=\underline{\text{C}}\text{H}$), 7.13-7.32 (5H, m, aromatic H's); C^{13} NMR δ (CDCl_3 , 100 MHz) 14.30 (CH_3), 63.76 ($\underline{\text{C}}\underline{\text{H}}_2\text{CH}_3$), 68.05 ($\underline{\text{C}}\underline{\text{H}}_2\text{OCO}_2\text{Et}$), 122.75 ($\text{CH}=\underline{\text{C}}\text{H}-\text{CH}_2$), 126.52, 128.18, 128.45(aromatic H's), 134.24 ($\text{Ph}-\text{CH}=\underline{\text{C}}\text{H}$), 135.98 ($\text{Ph}-\underline{\text{C}}\text{H}=\text{CH}$), 154.93 (OCO_2Et); m/z Compound did not site an interpretable mass spec.

3.4.1(b). 4-Nitro-1-phenylbutene

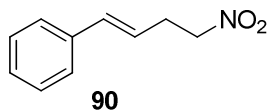

A flask purged with N_2 was loaded with nitromethane (8.0 ml). Cinnamyl ethyl carbonate (**89**) (0.40 g, 1.9 mmol) was then dissolved in some nitromethane and syringed in the flask followed by PPh_3 (0.06 g, 10 mol %) and DBA_3Pd_2 (0.045g, 2.5 mol %). After 3 hours the reaction was concentrated *in vacuo* which was subsequently followed by elution with ether (30ml) through a glass frit layered with MgSO_4 and SiO_2 . The obtained product was passed through a column in 80:20 Hexane-EtOAc solvent system to yield **90** (0.19 g, 58%) as a colourless oil.¹²¹

90: R_f (80:20 Hexane: EtOAc) 0.49; **IR** (KBr thin film) $\nu_{\text{max}}/\text{cm}^{-1}$ 3085-3010 m (C=C), 2990-3020 m (aromatics), 1645 w (C=C), 1389-1270 s (NO_2), 1548, 1494 s (NO_2), 699-972 s (C=C); ^1H NMR δ (CDCl_3 , 400 MHz) 2.83 (2H, ddt, $J=6.9, 1.2$ Hz, $\text{CH}=\text{CH}-\underline{\text{C}}\underline{\text{H}}_2$), 4.42 (2H, t, $J=6.9$ Hz, $\underline{\text{C}}\underline{\text{H}}_2\text{NO}_2$), 6.03 (1H, dt, $J=7.0, 15.7$ Hz, $\text{CH}=\underline{\text{C}}\text{H}-\text{CH}_2$), 6.58 (1H, br d, $J= 15.9$ Hz, $\text{Ph}-\text{CH}=\underline{\text{C}}\text{H}$), 7.11-7.28 (5H, m, aromatic H's); ^{13}C NMR δ (CDCl_3 , 100 MHz) 30.73 ($\text{CH}=\text{CH}-\underline{\text{C}}\underline{\text{H}}_2$), 75.10 ($\underline{\text{C}}\underline{\text{H}}_2\text{NO}_2$), 122.87 ($\text{CH}=\underline{\text{C}}\text{H}-\text{CH}_2$), 126.29, 127.83, 128.72, 134.05 (aromatics and $\text{Ph}-\underline{\text{C}}\text{H}=\text{CH}$), 136.47 ($(\text{Ph})\underline{\text{C}}-\text{CH}=\text{CH}$); m/z Compound did not site an interpretable mass spec.

3.4.2(a). 2-nitro-1-phenylpent-4-en-1-ol

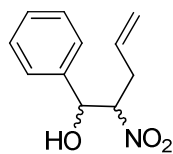

(diastereomers)

92

Attempted Test Henry with Benzaldehyde

Benzaldehyde (0.02ml, 0.24 mmol) was added via a syringe to a stirred mixture of 4-nitrobutene (**78**) (0.22 g, 2.13 mmol) KOH (5 mg saturated aqueous solution) and PEG400 (0.1 ml) kept at 60 °C over a period of 30 min. The reaction mixture was stirred for 1.5 hours at 60 °C. The reaction was monitored for a day, but TLC showed no product formation. The reaction mixture was extracted with ether and (3 × 10 ml) washed with 1N HCl (3 × 5 ml) and water (3 × 5 ml). The solvent was removed under reduced pressure and the residue analysed by NMR spectroscopy.¹²²

NOTE: Compound 92 was not cited in ref 122 but their method of preparation was as cited.

NMR showed reactant peaks. No expected product peaks were detected.

3.4.2(b). (E)-2-nitro-1, 5-diphenylpent-4-en-1-ol-Diastereomer A and B

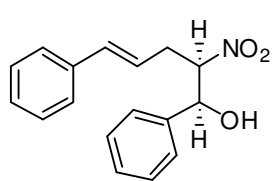

93a

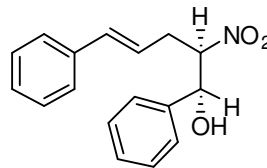

93b

Benzaldehyde (0.04 ml, 0.43 mmol) was added to 4-Nitro-1-phenylbutene (**90**) (0.10 g, 0.56 mmol) and triethylamine (0.06 ml, 0.44 mmol) in water (2.5 ml) for 6 hours at room temperature. The reaction was extracted with diethyl ether (3 × 5 ml) and dried over MgSO₄. Solvent was removed under reduced pressure followed by subsequent

column chromatography in 70:30 Hexane-EtOAc solvent system to obtain a mixture of diastereomers **93a** and **93b** (0.02 g, 13 %).¹²³

NOTE: (1) Compound 93a and b were not cited in ref 123 but their method of preparation was as cited. (2) Diastereomers A and B refer to compounds 93a and 93b.

Ratio of Diastereomer A and B is 1:6

Diastereomer A

R_f (70:30 Hexane: EtOAc) 0.71; **IR** (KBr thin film) $\nu_{\max}/\text{cm}^{-1}$ 3199-3550 br, s (OH), 3089-3025 m (C=C), 2990-3099 m (aromatics), 1645 w (C=C), 1389-1270 s (NO₂), 1548-1495 s (NO₂), 650-904 s (C=C); **¹H NMR** δ (CDCl₃, 400 MHz) 2.74 (1H, m, CH_aH_b-CH-NO₂), 2.97 (1H, dd, $J=11.6, 21.1$ Hz, CH_aH_b-CH-NO₂), 4.69 (1H, m, CH₂-CH-NO₂), 5.20 (1H, d, $J=5.1$ Hz, Ph-CH-OH), 5.96 (1H, ddd, $J=6.6, 7.9, 15.7$ Hz, CH=CH-CH₂), 6.37 (1H, d, $J=15.7$ Hz, Ph-CH=CH) 7.08-7.44 (10H, m, aromatic H's); **m/z** (CI +ve) found 306.1 (M+Na)⁺ required 306.

Diastereomer B

R_f (70:30 Hexane: EtOAc) 0.62; **¹H NMR** δ (CDCl₃, 400 MHz) 2.28 (1H, m, CH_aH_b-CH-NO₂), 2.62 (1H, m, CH_aH_b-CH-NO₂), 4.75 (1H, ddd, $J=3.9, 9.0, 10.2$ Hz, CH₂-CH-NO₂), 5.04 (1H, d, $J=8.9$ Hz, Ph-CH-OH), 5.86 (1H, ddd, $J=6.4, 8.1, 15.6$ Hz, CH=CH-CH₂), 6.28 (1H, d, $J=15.7$ Hz, Ph-CH=CH), 7.08-7.44 (10H, m, aromatic H's).

3.5. Strategy C

3.5.1(a). 1-nitropent-3-en-2-ol

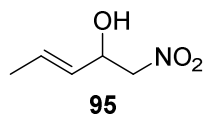

Bromonitromethane (0.5 ml, 7.39 mmol) was added to a mixture of SnCl₂ (1.37 g, 7.22 mmol) in diethyl ether (12 ml) and the mixture was sonicated for 20 minutes. Crotonaldehyde (0.6 ml, 7.24 mmol) was added and sonication was continued for another 7 hours. The reaction was neutralised with saturated hydrogen carbonate (10

ml), diluted with water (10ml) and extracted with diethyl ether (3 × 25ml). The combined organic layer was dried with magnesium sulphate and concentrated *in vacuo*. The residue was then purified by flash chromatography in 70:30 Hexane-EtOAc solvent system to yield **95** (0.64 g, 68%) as a colourless oil.¹²⁴

95: **R_f** (70:30 Hexane: EtOAc) 0.36; **IR** (KBr thin film) $\nu_{\max}/\text{cm}^{-1}$ 3000-2850 s (OH), 1679 m (C=C), 1672-1252 s (NO₂), 650-950 s (C=C); **¹H NMR** δ (CDCl₃, 400 MHz) 1.67 (3H, ddd, $J=0.9, 1.6, 6.6$ Hz, CH₃), 4.35 (2H, d, $J=6.1$ Hz, CH₂NO₂), 4.74 (1H, dt, $J=6.3, 12.4$ Hz, CHOH), 5.40 (1H, ddq, $J=1.6, 6.7, 15.3$ Hz, CH_a=CH_b), 5.83 (1H, m, CH₃-CH_a=CH_b); **¹³C NMR** δ (CDCl₃, 100 MHz) 17.72 (CH₃) 69.70 (CHOH), 80.31 (CH₂), 127.42 (CH_a=CH_b), 130.84 (CH_a=CH_b); ***m/z*** (CI -ve) found 166 (M+Cl)⁻ required 166.

3.5.1(b). 1-phenyl-but-2-en-1-ol

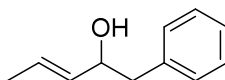

101

Attempted Tin (II) chloride reaction of crotonaldehyde with benzylbromide

Benzylbromide (0.4 ml, 3.36 mmol) was added to a mixture of SnCl₂ (0.59 g, 3.12 mmol) in diethylether (5 ml) and the mixture was sonicated for 20 minutes. Crotonaldehyde (0.25 ml, 3.01 mmol) was added and sonication was continued for another 7 hours. The TLC showed no signs of new product formation. After 2 days, the reaction was neutralised with saturated hydrogen carbonate (10 ml) and diluted with water (10ml) and extracted with diethyl ether (3× 25ml). The combined organic layer was dried with magnesium sulphate and concentrated *in vacuo*. Analysis was done using NMR spectroscopy.¹²⁴

NMR showed reactant peaks.

3.5.1(c). (3-nitropropyl) benzene

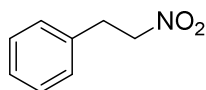

102

Attempted Tin (II) chloride reaction of bromonitromethane with benzylbromide

Bromonitromethane (0.2ml, 2.86 mmol) was added to a mixture of SnCl₂ (0.56 g, 2.94 mmol) in diethyl ether (5ml) and the mixture was sonicated for 20 minutes. Benzylbromide (0.35 ml, 2.94 mmol) was added and sonication was continued for another 7 hours. The TLC showed no signs of new product formation. After 2 days, the reaction was neutralised with saturated hydrogen carbonate (10 ml) and diluted with water (10ml) and extracted with diethyl ether (3 × 25ml). The combined organic layer was dried with magnesium sulfate and concentrated *in vacuo*. Analysis was done by NMR spectroscopy.¹²⁴

NMR showed reactant peaks. No expected product peaks were detected.

NOTE: Compounds 101 and 102 are not cited in Ref. 124 but their method of preparation was used for the above mentioned attempted reactions.

3.5.2. 2-nitro-1-phenylhex-4-en-3-ol

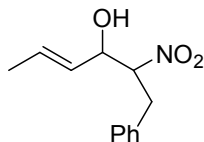

104

Attempted Seebach Alkylation at C2 position

A solution of lithium diisopropylamide (0.73ml, 5.4mmol, 7M) in dry THF (45 ml) was cooled to -78 °C using a dry ice bath. Tetramethylethylenediamine (3ml) and 1-nitropent-3-en-2-ol (**95**) (0.34 g, 2.6 mmol) was added to the cold solution (-78 °C) and the reaction mixture was stirred for 1 hour. The solution was then cooled to -100 °C using a methanol/liquid N₂ bath followed by the addition of the benzyl bromide (0.32ml, 2.7mmol). The reaction was monitored using TLC for 2 days at -78 °C, but no indication of product formation was detected. After 2 days, the reaction was extracted

with ether (3 × 10 ml) and washed with 1N HCl (3 × 10 ml) and water (3 × 10 ml). The combined organic layer was dried over magnesium sulphate and concentrated *in vacuo*.¹²⁵

NMR showed only reactant peaks. No expected product peaks were detected.

NOTE: Compounds 104 is not cited in Ref. 125 but the method of preparation given in Ref. 125 is used in the current work.

3.6. Dehydration

3.6.1. (1E, 3E)-1-nitropenta-1, 3-diene, (1E,3Z)-1-nitropenta-1,3-diene

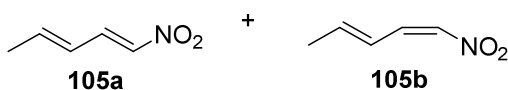

Attempted *in situ* Dehydration

1 equiv of methanesulfonyl chloride (0.027ml, 0.36 mol) was added to 1-nitropent-3-en-2-ol (**95**) (0.0480g, 0.36mmol) in CDCl₃ (2ml) at 0 °C under N₂ atmosphere. Triethylamine (0.2ml, 1.44 mol) was added dropwise to the reaction mixture for 15 minutes at 0 °C. The solution was given for NMR.

Complex peaks were observed and thus the (E, E) and (E, Z) isomers peaks couldn't be distinguished. Mesylate peaks could be identified.¹²⁶

NOTE: Compounds 105a and 105b are not cited in Ref. 126 but a general dehydration method for their preparation was as sited.

3.6.2. (1Z, 4E)-2-nitro-1,5-diphenylpenta-1,4-dien-1-ol, (1E, 4E)-2-nitro-1,5-diphenylpenta-1,4-dien-1-ol

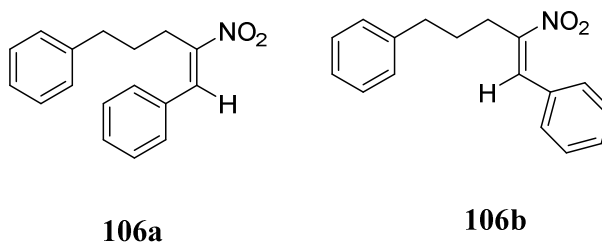

Attempted in situ Dehydration

1 equiv of methanesulfonyl chloride (0.004 ml, 0.05 mmol) was added to (E)-2-nitro-1,5-diphenylpent-4-en-1-ol (**93**) (0.015 g, 0.054 mmol) in CDCl₃ (2 ml) at 0 °C under N₂ atmosphere. Triethylamine (0.03 ml, 0.21 mmol) was added dropwise to the reaction mixture for 15 min at 0 °C. The solution was given for NMR.¹²⁶

Peaks for (E, E) and (E, Z) did' not grow substantially in order to interpret the NMR.

NOTE: Compounds 106a and 106b are not cited in Ref. 126 but a general dehydration method for their preparation was as sited.

REFERENCES

- 1) G. M. Blackburn, M. J. Gait, D. Loakes and D. M. Williams, *Nucleic Acid in Chemistry and Biology*, Oxford University press, London, 3rd edn., 2006, pp. 1-12.
- 2) H. Hart, L. E. Craine and D. J. Hart, *Organic Chemistry: A Short Course*, Houghton Mifflin Company, Boston, 11th edn., 2002, pp. 515-534.
- 3) C. K. Mathews, K. E. Van Holde and K. G. Ahern, *Biochemistry*, Addison Wesley Longman, San Francisco; Harlow, 3rd edn., 2000, pp. 84-87.
- 4) I. Tinoco Jr. and C. Bustamante, *J. Mol. Biol.*, 1993, **293**, 271-281.
- 5) J. T. Madison, *Annu. Rev. Biochem.*, 1968, **37**, 131-148.
- 6) P. J. Bredenbeek, C. J. Pachuk, A. F. H. Noten, J. Charité, W. Luytjes, S. R. Weiss and W. J. M. Spaan, *Nucleic Acids Res.*, 1990, **18**, 1825-1832.
- 7) *RNA Structural Motifs*, ed. M. Zhang, A. S. Perelson and C. S. Tung, John Wiley & Sons, Chichester, 2011.
- 8) *tRNA: Structure, Biosynthesis, and Function*, ed. D. Söll and U. L. RajBhandary, American Society for Microbiology, Washington, DC, 1995.
- 9) S. E. Butcher and A. M. Pyle, *Acc. Chem. Res.*, 2011, **44**, 1302-1311.
- 10) *RNA Structure: Tetraloops*, ed. C. Cheong and H. K. Cheong, John Wiley & Sons, Chichester, 2010.
- 11) R. T. Batey, R. P. Rambo and J. A. Doudna, *Angew. Chem., Int. Ed. Engl.*, 1999, **38**, 2326-2343.
- 12) C. Bauder, *Org. Biomol. Chem.*, 2008, **6**, 2952-2960.
- 13) J. Liu and D. M. J. Lilley, *RNA*, 2007, **13**(2), 200-210.
- 14) B. Wimberly, G. Varani and I. Tinoco Jr., *Biochemistry*, 1993, **32**, 1078-1087.
- 15) N. B. Leontis and E. Westhof, *RNA*, 1998, **4**, 1134-1153.
- 16) A. Dallas and P. B. Moore, *Structure*, 1997, **5**(12), 1639-1653.
- 17) *RNA Structure*, ed. Y. Chen and G. Varani, John Wiley & Sons, Chichester, 2010.
- 18) C. Geary, A. Chworos and L. Jaeger, *Nucleic Acids Res.*, 2011, **39**, 1066-1080.

- 19) E. Bindewald, R. Hayes, Y. G. Yingling, W. Kasprzak and B. A. Shapiro, *Nucleic Acids Res.*, 2008, **36**, D392-D397.
- 20) C. Laing, S. Jung, A. Iqbal and T. Schlick, *J. Mol. Biol.*, 2009, **393**, 67-82.
- 21) D. E. Draper, *RNA*, 2004, **10**, 335-343.
- 22) D. J. Klein, P. B. Moore and T. A. Steitz, *RNA*, 2004, **10**, 1366-1379.
- 23) S. A. Woodson, *Curr. Opin. Chem. Biol.*, 2005, **9**, 104-109.
- 24) P. Nissen, J. A. Ippolito, N. Ban, P. B. Moore and T. A. Steitz, *Proc. Natl. Acad. Sci. U.S.A.*, 2011, **98**, 4899-4903.
- 25) M. Selmer, C. M. Dunham, F. V. Murphy IV, A. Weixlbaumer, S. Petry, A. C. Kelley, J. R. Weir and V. Ramakrishnan, *Science*, 2006, **313**, 1935-1942.
- 26) H. Jin, A. C. Kelley, D. Loakes and V. Ramakrishnan, *Proc. Natl. Acad. Sci. U.S.A.*, 2010, **107**, 8593-8598.
- 27) J. Kjems, M. Brown, D. D. Chang and P. A. Sharp, *Proc. Natl. Acad. Sci. U.S.A.*, 1991, **88**, 683-687.
- 28) M. H. Malim, J. Hauber, S. Y. Le, J. V. Maizel and B. R. Cullen, *Nature*, 1989, **338**, 254-257.
- 29) M. Emerman, R. Vazeux and K. Peden, *Cell*, 1989, **57**, 1155-1165.
- 30) D. D. Chang and P. Sharp, *Cell*, 1989, **59**, 789-795.
- 31) M. L. Hammarskjöld, J. Heimer, B. Hammarskjöld, I. Sangwan, L. Albert and D. J. Rekosh, *J. Virol.*, 1989, **63**, 1959-1966.
- 32) D. A. Mann, I. Mikaelian, R. W. Zimmel, S. M. Green, A. D. Lowe, T. Kimura, M. Singh, P. J. Butler, M. J. Gait and J. Karn, *J. Mol. Biol.*, 1994, **241**, 193-207.
- 33) E. T. Dayton, D. M. Powell and A. I. Dayton, *Science*, 1989, **246**(4937), 1625-1629.
- 34) M. L. Zapp and M. R. Green, *Nature*, 1989, **342**, 714-716.
- 35) T. J. Daly, K. S. Cook, G. S. Gray, T. E. Maione and J. R. Rusche, *Nature*, 1989, **342**, 816-819.
- 36) H. S. Olsen, P. Nelbock, A. W. Cochrane and C. A. Rosen, *Science*, 1990, **247**, 845-848.
- 37) A. W. Cochrane, C. H. Chen and C. A. Rosen, *Proc. Natl. Acad. Sci. U.S.A.*, 1990, **87**, 1198-1202.

- 38) S. Heaphy, C. Dingwall, I. Ernberg, M. J. Gait, S. M. Green, J. Karn, A. D. Lowe, M. Singh and M. A. Skinner, *Cell*, 1990, **60**, 685-693.
- 39) B. Charpentier, F. Stutz and M. Robash, *J. Mol. Biol.*, 1997, **266**, 950-962.
- 40) M. H. Malim and B. R. Cullen, *Cell*, 1991, **65**, 241-248.
- 41) K. S. Cook, G. J. Fisk, J. Hauber, N. Usman, T. J. Daly and J. R. Rusche, *Nucleic Acids Res.*, 1991, **19**, 1577-1583.
- 42) T. J. Hope, D. McDonald, X. J. Huang, J. Low and T. G. Parslow, *J. Virol.*, 1990, **64**, 5360-5366.
- 43) M. H. Malim, L. S. Tiley, D. F. McCarn, J. R. Rusche, J. Hauber and B. R. Cullen, *Cell*, 1990, **60**, 675-683.
- 44) X. J. Huang, T. J. Hope, B. L. Bond, D. McDonald, K. Grahl and T. G. Parslow, *J. Virol.*, 1991, **65**, 2131-2134.
- 45) S. Heaphy, J. T. Finch, M. J. Gait, J. Karn and M. Singh, *Proc. Natl. Acad. Sci. U.S.A.*, 1991, **88**, 7366-7370.
- 46) J. Kjems, B. J. Calnan, A. D. Frankel and P. Sharp, *EMBO J.*, 1992, **11**, 1119-1129.
- 47) R. Tan, L. Chen, J. A. Buettner, D. Hudson and A. D. Frankel, *Cell*, 1993, **73**, 1031-1040.
- 48) J. L. Battiste, H. Mao, N. S. Rao, R. Tan, D. R. Muhandiram, L. E. Kay, A. D. Frankel and J. R. Williamson, *Science*, 1996, **273**, 1547-1551.
- 49) M. D. Daugherty, I. D'Orso and A. D. Frankel, *J. Mol. Cell.*, 2008, **31**, 824-834.
- 50) C. Jain and J. G. Belasco, *Mol. Cell*, 2011, **7**, 603-614.
- 51) S. P. Edgcomb, A. Aschrafi, E. Kompfner, J. R. Williamson, L. Gerace and M. Hennig, *Protein Sci.*, 2008, **17**, 420-430.
- 52) J. D. Fernandes, B. Jayaraman and A. D. Frankel, *RNA Biology*, 2012, **9**(11), 6-11.
- 53) M. D. Daugherty, B. Liu and A. D. Frankel, *Nat. Struct. Mol. Biol.*, 2010, **17**, 1337-1342.
- 54) M. A. DiMattia, N. R. Watts, S. J. Stahl, C. Rader, P. T. Wingfield, D. Stuart, A. C. Steven and J. Grimes, *Proc. Natl. Acad. Sci. U.S.A.*, 2010, **107**, 5810-5814.
- 55) M. D. Daugherty, D. S. Booth, B. Jayaraman, Y. Cheng and A. D. Frankel, *Proc. Natl. Acad. Sci. U.S.A.*, 2010, **107**, 12481-12486.

- 56) S. J. Pond, W. K. Ridgeway, R. Robertson, J. Wang and D. P. Millar, *Proc. Natl. Acad. Sci. U.S.A.*, 2009, **106**, 1404-1408.
- 57) D. McDonald, T. J. Hope and T. G. Parslow, *J. Virol.*, 1992, **66**, 7232-7238.
- 58) S. Venkatesan, S. M. Gerstberger, H. Park, S. M. Holland and Y. Nam, *J. Virol.*, 1992, **66**, 7469-7480.
- 59) Y. S. Nam, A. Petrovic, K. S. Jeong and S. Venkatesan, *J. Virol.*, 2001, **75**, 2957-2971.
- 60) J. Kijems and P. A. Sharp, *J. Virol.*, 1993, **67**, 4769-4776.
- 61) T. L. Symensma, S. Baskerville, A. Yan and A. D. Ellington *J. Virol.*, 1999, **73**, 4341-4349.
- 62) M. C. Good, J. G. Zalatan and W. A. Lim, *Science*, 2011, **332**, 680-686.
- 63) H. F. Noller, *Science*, 2005, **309**, 1508-1514.
- 64) M. C. Wahl, C. L. Will and R. Luhrmann, *Cell*, 2009, **136**, 701-718.
- 65) D. C. Zappulla and T. R. Cech, *Proc. Natl. Acad. Sci. U.S.A.*, 2004, **101**, 10024-1002.
- 66) S. F. Ataide, N. Schmitz, K. Shen, A. Ke, S. O. Shan, J. A. Doudna and N. Ban, *Science*, 2011, **331**, 881-886.
- 67) M. H. Malin, S. Bohnlein, J. Hauber and B. R. Cullen, *Cell*, 1989, **58**, 205-214.
- 68) M. Legiewicz, C. S. Badorrek, K. B. Turner, D. Fabris, T. E. Hamm, D. Rekosh, M. L. Hammarskjold, S. F. J. Le Grice, *Proc. Natl. Acad. Sci. U.S.A.*, 2008, **105**, 14365-14370.
- 69) *US Pat.*, 5534408, 1996.
- 70) F. Kudo, Y. Yamamoto, K. Yokoyama and T. Eguchi, *J. Antibiot.*, 2005, **58**, 766-774.
- 71) B. E. Leach and C. M. Teeters, *J. Am. Chem. Soc.*, 1951, **73**, 2794.
- 72) F. A. Kuehl, M. N. Bishop, N. J. Rahway and K. Folkers, *J. Am. Chem. Soc.*, 1951, **73**, 881.
- 73) B. E. Leach and C. M. Teeters, *J. Am. Chem. Soc.*, 1952, **74**, 3187.
- 74) M. P. Georgiadis, V. Constantinou-Kokotou, G. J. Kokotos, *J. Carbohydr. Chem.*, 1991, **10**, 739.

- 75) P. B. Alper, S.-C. Hung and C.-H. Wong, *Tetrahedron Lett.*, 1996, **37**, 6029.
- 76) *Eu Pat.*, WO01/39726A2, 2001, submitted.
- 77) *US Pat.*, US2002/0052526 A1, 2002, submitted.
- 78) Y. Ding, S. A. Hofstadler, E. E. Swayze and R. H. Griffer, *Chem. Lett.*, 2003, **32**, 908
- 79) G. F. Busscher, S. Groothuys, R. de Gelder, F. P. J. T. Rutjes and F. L. Delft, *J. Org. Chem.*, 2004, **69**, 4477.
- 80) S. Takano, M. Moriya, T. Kamikubo, K. Hiroya and K. Ogasawara, *Tetrahedron Lett.*, 1993, **34**, 8485.
- 81) P. Serrano, A. Llebaria and A. Delgado, *J. Org. Chem.*, 2002, **67**, 7165.
- 82) E. Vedejs and S. D. Larsen, *J. Am. Chem. Soc.*, 1984, **106**, 3030.
- 83) S. A. M. W. van den Broek, B. W. T. Gruijters, F. P. J. T. Rutjes, F. L. van Delft and R. H. Blaauw, *J. Org. Chem.*, 2007, **72**, 3577-3580.
- 84) A. Dondoni and D. Perrone, *Synthesis*, 1993, 1162-1176.
- 85) M. Scholl, S. Ding, C. W. Lee and R. H. Grubbs, *Org. Lett.*, 1999, **1**, 953-956.
- 86) T. K. M. Shing, E. K. W. Tam, V. W. -F. Tai, I. H. F. Chung, Q. Jiang, *Chem. Eur. J.*, 1996, **2**, 50-57.
- 87) B. M. Kim and K. B. Sharpless, *Tetrahedron Lett.*, 1989, **30**, 658-665.
- 88) R. J. Ferrier and S. Middleton, *J. Chem. Soc., Perkin trans.1*, 1979, 1455-1458.
- 89) O. L. Lopez, J. G. Fernández-Bolños, V. H. Lillelund and M. Bols, *Org. Biomol. Chem.*, 2003, **1**, 478-482.
- 90) L. -X. Wang, N. Sakairi and H. Kuzuhara, *Carbohydr. Res.*, 1995, **275**, 33-47.
- 91) P. M. Enright, K. M. O'Boyle and P. V. Murphy, *Org. Lett.*, 2000, **2**, 3929-3932.
- 92) J. L. O'Brien, M. Tosin and P. V. Murphy, *Org. Lett.*, 2001, **3**, 3353-3356.
- 93) C. McDonnell, L. Cronin, J. L. O'Brien and P. V. Murphy, *J. Org. Chem.*, 2004, **69**, 3565-3568.
- 94) D. Horton and A. Khare, *Carbohydr. Res.*, 2006, **341**, 2631-2640.
- 95) R. Blattner, R. J. Ferrier and S. R. Haines, *J. Chem. Soc., Perkin trans.1*, 1985, 2413-2416.

- 96) C. Bauder, *Org. Biomol. Chem.*, 2008, **6**, 2952-2960.
- 97) B. Orsat, P. B. Alper, W. Moree, C.-P. Mak and C.-H. Wong, *J. Am. Chem. Soc.*, 1996, **118**, 712.
- 98) S. Grabowski, J. Armbruster and H. Prinzbach, *Tetrahedron Lett.*, 1997, **38**, 5485.
- 99) W. A. Greenberg, E. S. Priestley, P. S. Sears, P. B. Alper, C. Rosenbohm, M. Hendrix, S. -C. Hung and C, -H, Wong, *J. Am. Chem. Soc.*, 1999, **121**, 6527-6541.
- 100) R. Downham, P. J. Edwards, D. A. Entwistle, A. B. Hughes, K. S. Kim and S. V. Ley, *Tetrahedron: Asymmetry*, 1995, **6**, 2403.
- 101) T. W. Craig, G. P. Harvey and G. A. Berchtold, *J. Org. Chem.*, 1967, **32**, 3743.
- 102) G. Kavadias, S. Velkof and B. Belleau, *Can. J. Chem.*, 1978, **56**, 404-409.
- 103) G. D. Daves Jr., R. K. Robins and C. C. Cheng, *J. Am. Chem. Soc.*, 1962, **84**, 1724.
- 104) T. A. Montzka, T. L. Pindell and J. D. Mattiskella, *J. Org. Chem.*, 1968, **33**, 3993.
- 105) S. Umezawa, Y. Tagaki and T. Tsuchiya, *Bull. Chem. Soc. Jpn*, 1971, **44**, 1411.
- 106) T. Suami, S. Ogawa, H. Uchino and Y. Funaki, *J. Org. Chem.*, 1975, **40**, 456-461.
- 107) R. Chênevert and F. Jacques, *Tetrahedron: Asymmetry*, 2006, **17**, 1017-1021.
- 108) H. C. Kolb, M. G. Finn and K. B. Sharpless, *Angew. Chem., Int. Ed.*, 2001, **40**, 2004-2021.
- 109) D. Vourloumis, G. C. Winters, K. B. Simonsen, M. Takahashi, B. K. Ayida, S. Shandrick, Q. Zhao, Q. Han and T. Hermann, *ChemBioChem*, 2005, **6**, 58-65.
- 110) A. H. Hoveyda, D. A. Evans and G. C. Fu, *Chem. Rev.*, 1993, **93**, 1307.
- 111) E. L. Ruggles, P. B. Decker and R. J. Hondal, *Tetrahedron*, 2009, **65**, 1257-1267.
- 112) J. P. Agrawal, R. D. Hodgson, *Organic Chemistry of Explosives*, John Wiley & Sons Ltd., Chichester, 2007, pp. 7-8.
- 113) R. Ballini, L. Barboni, G. Giarlo and S. Chimiche, *J. Org. Chem.*, 2004, **1**, 6907-6908.
- 114) R. Ballini, L. Barboni and A. Palmieri, *Green Chem.*, 2008, **10**, 1004.

- 115) M. Kidwai, A. Jahan and D. Bhatnagar, *J. Chem. Sci.*, 2010, **122**(4), 607-612.
- 116) L. A. Ferreira and J. A. Teixeira, *J. Chem. Thermodyn.*, 2011, **43**, 1299-1304.
- 117) G. P. Marsh, P. J. Parsons, C. McCarthy and X. G. Corniquet, *Org. Lett.*, 2007, **9**, 2613-2616.
- 118) P. J. Hérisson and Y. Chauvin, *Die Macromolekulare Chemie*, 1971, **141**, 161-176.
- 119) A. K. Chatterjee, T. Choi, D. P. Sanders and R. H. Grubbs, *J. Am. Chem. Soc.*, 2003, **125**, 11360-11370.
- 120) J. McNulty and R. Mo, *Chem. Commun.*, 1998, **3**, 933-934.
- 121) D. R. Deardorff, K. A. Savin, C. J. Justman, Z. E. Karanjawala, J. E. Sheppeck II, D. C. Hager and N. Aydin, *J. Org. Chem.*, 1996, **61**, 3616-3622.
- 122) A. Bhattacharya and V. C. Purohit, *Org. Process Res. Dev.*, 2003, **7**, 254-258.
- 123) C. L. Zhou, Y. Q. Zhou and Z. Y. Wang, *Chin. Chem. Lett.*, 2003, **14**, 355-358.
- 124) A. S. Mahasneh, *Z. Naturforsch, B, Chem. Sci.*, 2005, **60**, 416-418.
- 125) D. Seebach, A. K. Beck, T. Mukhopadhyay and E. Thomas, 1982, *Helv. Chim. Acta*, **65**, 1101-1133.
- 126) J. Melto and J.E. McMurry, *J. Org. Chem.*, 1975, **40**, 2138-2139.