

UNIVERSITY *of* York

This is a repository copy of *Genetic Determinism vs. Phenotypic Plasticity in Protist Morphology*.

White Rose Research Online URL for this paper:
<https://eprints.whiterose.ac.uk/113304/>

Article:

Mulot, Matthieu, Marcisz, Katarzyna, Grandgirard, Lara et al. (6 more authors) (2017)
Genetic Determinism vs. Phenotypic Plasticity in Protist Morphology. *Journal of Eukaryotic Microbiology*. ISSN 1066-5234

<https://doi.org/10.1111/jeu.12406>

Reuse

Items deposited in White Rose Research Online are protected by copyright, with all rights reserved unless indicated otherwise. They may be downloaded and/or printed for private study, or other acts as permitted by national copyright laws. The publisher or other rights holders may allow further reproduction and re-use of the full text version. This is indicated by the licence information on the White Rose Research Online record for the item.

Takedown

If you consider content in White Rose Research Online to be in breach of UK law, please notify us by emailing eprints@whiterose.ac.uk including the URL of the record and the reason for the withdrawal request.

DR. MATTHIEU MULOT (Orcid ID : 0000-0002-8039-5078)

DR. EDWARD A.D MITCHELL (Orcid ID : 0000-0003-0358-506X)

Received Date : 26-Aug-2016

Revised Date : 05-Jan-2017

Accepted Date : 16-Feb-2017

Article type : Original Article

Mulot et al.--- Protist Phenotypic Plasticity

Genetic Determinism vs. Phenotypic Plasticity in Protist Morphology

Matthieu Mulot ^a, Katarzyna Marcisz ^b, Lara Grandgirard ^a, Enrique Lara ^a, Anush Kosakyan ^c, Bjorn JM Robroek ^{d,e,f}, Mariusz Lamentowicz ^b, Richard J. Payne ^g, and Edward A. D. Mitchell ^{a,h}

a Laboratory of Soil Biodiversity, University of Neuchatel, Rue Emile-Argand 11, Neuchatel 2000, Switzerland

b Laboratory of Wetland Ecology and Monitoring & Department of Biogeography and Paleoecology, Adam Mickiewicz University, Krygowskiego 10, 61-680 Poznan, Poland

c Laboratory of Evolutionary Protistology, Institute of Biosciences, University of Sao Paulo, Matao Travessa 14 Cidade Universitaria, Sao Paulo, 05508-090 SP, Brazil

d Ecology and Biodiversity Group, Faculty of Science, Utrecht University, Padualaan 8, 3585 CH Utrecht, The Netherlands

e Ecole Polytechnique Federale de Lausanne, Ecological Systems Laboratory, Lausanne CH-1015, Switzerland

f WSL Swiss Federal Institute for Forest, Snow and Landscape Research, Site Lausanne, Lausanne CH-1015, Switzerland

g Environment, University of York, York YO105DD, United Kingdom

h Jardin Botanique de Neuchatel, Chemin du Perthuis-du-Sault 58, Neuchatel 2000, Switzerland

This article has been accepted for publication and undergone full peer review but has not been through the copyediting, typesetting, pagination and proofreading process, which may lead to differences between this version and the Version of Record. Please cite this article as doi: 10.1111/jeu.12406-4877

This article is protected by copyright. All rights reserved.

Correspondence

M. Mulo, Laboratory of Soil Biodiversity, University of Neuchatel, Rue Emile-Argand 11, Neuchatel 2000, Switzerland 30602, USA Telephone number: +33 649174305; e-mail: matthieu.mulot@unine.ch

ABSTRACT

Untangling the relationships between morphology and phylogeny is key to building a reliable taxonomy, but is especially challenging for protists, where the existence of cryptic or pseudocryptic species makes finding relevant discriminant traits difficult. Here we use *Hyalosphenia papilio* (a testate amoeba) as a model species to investigate the contribution of phylogeny and phenotypic plasticity in its morphology. We study the response of *Hyalosphenia papilio* morphology (shape and pores number) to environmental variables in 1) a manipulative experiment with controlled conditions (water level), 2) an observational study of a withinsite natural ecological gradient (water level), and 3) an observational study across 37 European peatlands (climate). We showed that *Hyalosphenia papilio* morphology is correlated to environmental conditions (climate and water depth) as well as geography, while no relationship between morphology and phylogeny was brought to light. The relative contribution of genetic inheritance and phenotypic plasticity in shaping morphology varies depending on the taxonomic group and the trait under consideration. Thus, our data call for a reassessment of taxonomy based on morphology alone. This clearly calls for a substantial increase in taxonomic research on these globally still under-studied organisms leading to a reassessment of estimates of global microbial eukaryotic diversity.

Keywords: body size, protozoa, soil moisture, testate amoebae, water table depth

UNTANGLING the relationships between morphology and phylogeny is key to building a reliable taxonomy, but remains a challenge even for well-known organisms (Grbic et al. 2015). Finding reliable discriminant traits to separate closely-related taxa is especially difficult for microscopic organisms such as nematodes, rotifers and unicellular protists that often lack clear diagnostic traits. Molecular studies have repeatedly revealed extensive evidence for "pseudocryptic" diversity; genetically distinct species that differ by only very subtle morphological details, typically only revealed by detailed morphometric analyses or electron-microscopy. The criteria to distinguish these species were often previously considered to be invalid (e.g. (Hebert et al. 2004)). The existence of extensive pseudocryptic diversity suggests that global biodiversity is considerably underestimated (Šlapeta et al. 2005) and has implications for applications such as biomonitoring, for which accurate taxonomy is essential. Cryptic diversity has been documented in numerous groups of protists including diatoms (Kooistra et al. 2010; Poulickova et al. 2004; Mann 2010), haptophytes (Medlin and Zingone 2007; Sáez et al. 2003), foraminiferans (Morard et al. 2009), euglyphid testate amoebae (Chatelain et al. 2013) and hyalospheniid testate amoebae (Corno and Jurgens 2006; Kosakyan et al. 2013; Singer et al. 2015). However, phenotypic plasticity has also been documented in several protist groups including diatoms and ciliates. Evidence exists for both subtle phenotypic effects, with no implication for taxonomy (Trobajo et al. 2011), and stronger phenotypic effects, which, if not understood as such, would possibly lead to

erroneous taxonomic splitting (Tuffrau et al. 2000; Bartual et al. 2008). In some cases (e.g. planktonic foraminifera), detailed analysis has shown that what was previously interpreted as phenotypic plasticity, is in fact cryptic diversity (Ujiié and Asami 2014).

Testate amoebae are a polyphyletic group of primarily terrestrial and freshwater free-living shelled protozoa that clearly illustrate the challenges that come with defining species in micro-eukaryotes (Kosakyan et al. 2013; Singer et al. 2015; Bobrov and Mazei 2004; Oliverio et al. 2014; Schlegel and Meisterfeld 2003). Testate amoebae show evidence for both clear correlation between morphological and genetic diversity (Gomaa et al. 2012; Heger et al. 2011; Kosakyan et al. 2012; Wylezich et al. 2002), and phenotypic plasticity, in response to food sources and temperature (Medioli et al. 1987; Wanner 1999). Discriminating taxonomically relevant traits from phenotypic plasticity is therefore challenging. Beyond simply causing taxonomic confusion, this issue potentially undermines their reliability as bioindicators (Mitchell et al. 2008; Payne et al. 2011; Payne 2013) and their value as model a group in microbial biogeography (Heger et al. 2009).

Here we address the questions of cryptic diversity and phenotypic plasticity using *Hyalosphenia papilio* (Leidy 1879) as a model. *H. papilio* is one of the most widely distributed, abundant, and well-studied testate amoeba species. It is a mixotrophic (i.e. it contains endosymbiotic algae) testate amoeba with a smooth proteinaceous shell. *H. papilio* has a circumboreal distribution and is abundant in northern *Sphagnum* peatlands (Gilbert & Mitchell 2015; Swindles et al. 2009; Woodland et al. 1998). Because of its decay-resistant shell, ease of identification, and sensitivity to variations in peatland water table depth, *H. papilio* is a key bioindicator in peatland ecology (Charman and Warner 1992; Marcisz, Lamentowicz, et al. 2014; Marcisz, Fournier, et al. 2014; Mitchell et al. 1999) and palaeoecology, where sub-fossil testate amoeba communities are used to infer past hydrological conditions (Booth 2002; Booth 2008; Charman 2001; Lamarre et al. 2013; Qin et al. 2013). *H. papilio* thus makes an excellent model to consider questions of phenotypic plasticity and genetic diversity. Considerable morphological variability of *H. papilio* has been reported with respect to shell size (90-175 µm in length) and the number of pores of *H. papilio* (2-10) (Bobrov & Mazei 2004; Bobrov et al. 1995) has recently been shown to correlate with water table depth (Booth & Meyers 2010), which suggests that this morphological trait might represent an example of environmentally-driven phenotypic plasticity. Alternatively, pore number and shell size could be inherited, and forms with high numbers of pores selected in moist environments. Indeed, in some members of the family (i.e. *Nebela collaris* group in *Hyalospheniidae*), a correlation between subtle variations in shell morphology and Cytochrome oxidase I gene (COI) sequence variation has been found (Kosakyan et al. 2013; Singer et al. 2015). Two recent studies have shown that *H. papilio* is genetically highly diverse, and constitutes a species complex (Oliverio et al. 2014; Heger et al. 2013); however, no morphological data support the separation of these genetically-distinct forms. Thus, it may well be that individuals with different pore numbers are genetically distinct. Shells with varying numbers of pores have been observed in another hyalosphenid testate amoebae: *Nebela gimlii* (Singer et al. 2015). This morphological character is therefore relevant for other *Hyalospheniidae* species. It follows that the observed morphological variation in *H. papilio* could be either due to genetic determinism or phenotypic plasticity. Our aim was to determine the relative influence of both factors using a combination of experimental and observational approaches. To our knowledge, the relative contribution of genetic and ecophysiological factors in determining morphology has never been addressed in protists. This knowledge-gap illustrates the considerable challenges in protist taxonomy.

MATERIAL AND METHODS

Morphological analyses

We studied the morphological variability of *Hyalosphenia papilio* using three complementary approaches:

1. a manipulative experiment with controlled conditions,
2. an observational study of a within-site natural ecological gradient,
3. an observational study across 37 European peatlands.

The first two components of our study focused on *H. papilio* pore number and water table, as wetness is known to be an important control on testate amoeba ecology and previous research suggests a link with pore numbers (Booth & Meyers 2010). The third component takes a broader perspective and focuses on biovolume and climate, based on evidence for temperature-size relationships in other protists (Bobrov et al. 1995). In our experimental study we also considered a suite of other morphological traits to investigate whether they differed systematically in response to manipulated water table depth. The relationships between morphology and physical or chemical variables (pH, DOC, etc.) were not investigated in the present studies as the datasets for this parameters were sparse and not consistent across the samples.

The manipulative experiment was designed to assess the effects of water table variation on the microbial communities of *Sphagnum fallax* mesocosms through time. We constructed mesocosms that consisted of a peat monolith topped by a *Sphagnum fallax* layer (Mulot et al. 2015). The water level in each mesocosm was adjusted to maintain three water table depths (AWTD: -4 cm, -15 cm, and -25 cm, hereafter referred to as "high", "intermediate" and "low" treatments). There were five replicates per treatment with a total of 15 mesocosms. From all mesocosms, we collected 3-5 shoots of the upper 3 cm (living part) of *Sphagnum* mosses. This was done seven times 08/08/2012 (T0), 04/10/2012 (T1), 29/11/2012 (T2), 04/03/2013 (T3), 11/08/2013 (T4), 15/12/2013 (T5), and 27/03/2014 (T6) across the experimental period.

Amoebae were extracted from *Sphagnum* shoots by filtering and back-filtering using mesh sizes of 250 and 20 μm following the procedures described in (Jassey et al. 2011; Nguyen-Viet et al. 2008). The number of pores of *H. papilio* specimen was counted for all the dates under 400X magnification. Ten specimens from the five mesocosms of respectively low and high water level treatment from T0 and T4 (i.e. ca. one year after T0) were randomly selected, observed and photographed at 400X magnification. The following morphological traits were measured using imageJ (Schneider et al. 2012) (Fig. 1): Maximum length (a), maximum width (b), pseudostome (aperture) width (c), orthogonal distance from the pseudostome to the maximum width axis (d), orthogonal distance from the pseudostome to the position of the top pore (i.e. the pore most distant from the aboral end of the shell) (e), linear distance from the pseudostome to the top pore (f), neck angle (α), pore number (p).

The natural gradient study was designed to investigate the response of testate amoeba communities to a water table gradient in a natural setting. We investigated the water table gradient in Linje mire (53°11'15"N, 18° 18'34"E), a *Sphagnum fallax*-dominated peatland in Poland (Marcisz et al. 2014; Slowinska et al. 2010). In each of five sites within the peatland, five permanently marked plots were selected in hummocks or lawns. *Sphagnum fallax* mosses were collected five times in the year 2013 (20/04, 07/06, 20/07, 01/09 and 25/10),

covering a full growing season. Samples were prepared as above and *H. papilio* pore number counted.

Finally, in the European-scale study we aimed to identify links between shell size and climate. We sampled mosses in 37 peatlands distributed across Europe (including 10 specimens from the manipulative experiment T0 samples) (Fig. S1). We extracted testate amoebae, as above, and calculated biovolume using the formula of Charrière et al. (Charrière et al. 2006). The dataset yielded measurements for 318 specimens which were related to bioclimatic data for these sites.

Data analysis

The morphological variability of *H. papilio* in relation to water table depth in the mesocosm experiment was tested using multivariate ratio analysis (MRA) (Baur & Leuenberger 2011). Morphological trait measurements were centered and scaled prior to analysis. We first computed a shape PCA to investigate how the morphology of the specimens was correlated to the treatments and time (explicitly T0 + High water level, T0 + Low water level, T4 + High water level, T4 + Low water level). We then calculated hierarchical clusters (Murtagh 1985) based on morphological trait ratios using Ward's method on a Euclidean dissimilarity matrix to understand the relationship between morphologically consistent groups and treatments. Finally, we performed a Fisher's linear discriminant analysis (LDA) to extract the best segregating ratios for clusters.

For the pore number data from both the manipulative experiment and the within---peatland natural gradient study we retained all samples with a minimum of 20 *H. papilio* specimens and tested the changes in morphotype abundance (Hellinger transformed matrix) through time using Principal Response Curves (PRC; (Van den Brink & Ter Braak 1999)) and ANOVA (Chambers & Hastie 1991).

For the European-scale study, we used bioclimatic data (BioClim (Hijmans et al. 2005) and altitude (Jarvis et al. 2008), and spatial structure (PCNM eigenvectors (Borcard and Legendre 2002)) as explanatory variables for biovolume. For each of these two subsets (bioclimatic and spatial) the variables which significantly ($p < 0.05$) explained biovolume were selected using glmulti (Calcagno & de Mazancourt 2010). The retained spatial eigenvectors were then divided into three spatial matrices: macroscale, mesoscale and microscale. The relative contribution of the selected bioclimatic variables was tested using the Relaimpo package (Grömping 2006) and are given in fig. S4.

Phylogenetic analysis

For the phylogenetic analysis, *H. papilio* specimens with contrasting morphologies (number of pores, size) were isolated from the manipulative experiment. Prior to isolation, each individual was photographed, and fixed in a guanidine thiocyanate buffer (Chomczynski & Sacchi 1987). Mitochondrial COI sequences were obtained using a nested PCR protocol (Gomaa et al. 2014) using a Promega GoTaq G2 kit. Sequences are deposited in GenBank with the following accession numbers XX--XX (nb. accession numbers will be added after paper acceptance).

The sequences were aligned and controlled manually using MUSCLE (Edgar 2004), and BioEdit (Hall 1999). A maximum likelihood tree was built in MEGA6 (Tamura et al. 2013) using the Tamura-Nei model with 16 gamma--distributed rate variation across sites and a proportion of invariant sites. Node robustness was tested using 500 bootstraps. We performed a Bayesian analysis in order to confirm the topology observed with Maximum likelihood using MrBayes v3.2 (Ronquist & Huelsenbeck 2003) with a general time reversible model of sequence evolution with 6 gamma--distributed rate variation across sites and a proportion of invariable sites. Bayesian MCMC analyses were carried out with two simultaneous chains, adding generations until the standard deviation of split frequencies fell below 0.01. We used sequences from *Nebela ansata* (GenBank number JN849055.1, JN849054.1) and *N. galeata* (Genbank number JN849060.1, JN849059.1, JN849058.1) to root all trees, as these species were shown to be closely related to *H. papilio* in a COI gene-based phylogeny of Hyalospheniidae (Kosakyan et al. 2012). We then assigned our sequences to the different lineages described in Heger et al. (2013).

RESULTS

Morphometric patterns in relation to water table depth

The shape PCA of morphometric data for the manipulative experiment showed that the morphology of *Hyalosphenia papilio* was different between the two sampling occasions but not between water table treatments (Fig. 2).

Based on morphological differences we identified two main groups. The LDA ratio extractor showed that the best segregating ratios for the two groups (T0 vs. T4) were angle/length and width/pores (Table 1).

Neither pore number nor the width/length ratio differed significantly between T0 and T4 (Wilcoxon test, $p > 0.05$). The morphological segregation between T0 and T4 was thus due to a simple isometric size reduction as also attested by the Pearson product moment correlation between length and isometric size of 0.97 (*i.e.* geometric means of morphological traits (Baur et al. 2014)). Thus the biovolume distribution did not overlap between T0 and T4. Two exceptions to this general pattern were however, the angle of the neck, which was more pronounced at T4 than T0 (mean = 119.5° , SD = 5.60 vs. $171.97^\circ \pm 13.49$; p -value < 0.05 , test = ANOVA) and the shell depth, which was normally distributed around a mean of $19.54 \mu\text{m}$ regardless of the overall size of the shell or of any other measured morphological feature. Although the PCA showed considerable overlap in the two treatments at both time points, the conditional inference tree of biovolume distribution against treatment (High/Low) and time (T0/T4) revealed a significant reduction in shell length at T + 1 year in the low water table treatment (Fig. 3).

In the manipulative experiment, the mean pore number increased from 2.02 to 2.18 pores per specimens in the high water level treatment from T0 to T6, while it decreased from 2.04 to 2.01 in the low water level treatment (t-test, $p < 0.05$; Fig. 4). In the field observational study mean pore number was also on average slightly higher in wet conditions (lawn), but this difference was not statistically significant (t-test, $p = 0.7$; Fig. 4).

The two PRC analyses showed a similar response, although only the PRC performed on the manipulative experiment samples was significant (table sup online). The PRC of pore number in the mesocosm study (Fig. 5) showed that specimens with more than two pores tend

to become more abundant in the wet plots throughout the year, whereas dry plots were consistently dominated by two pore specimens. This response became apparent one year after the beginning of the experiment (August 2013).

Morphometric patterns in relation to climate

In our analysis of links between bioclimate and morphology, 13 variables were significant: altitude, annual precipitation, mean diurnal temperature range, isothermality, mean temperature of the coldest month, precipitation of the driest month, precipitation of the wettest month, precipitation of the coldest quarter, precipitation of the driest and wettest quarters, annual temperature range, precipitation of warmest quarter and precipitation seasonality (see sup n for more details). For the spatial data, we retained PCNM 1-5 (macroscale), 7-9 (mesoscale), 12-16 (microscale).

Variance partitioning analysis showed that the four groups of variables jointly explained 48% of the variance in biovolume. The bioclimatic data explained the highest proportion of variance (11% alone, 44% associated with spatial data). Geographical location explained less than 7% of the variance, equally shared between mesoscale and microscale structure (Fig. 6). The four explanatory matrices were significant (ANOVA, $p < 0.05$). The size variation over this dataset is considerable with an almost three fold range in length (70.3 μm in Store Mosse, Sweden and 200.9 μm in Cena, Latvia). Size also varied considerably in relation to microhabitat (ANOVA, $p < 0.05$), with larger specimen occurring in lawns (mean length: 129.4 μm , standard deviation: 16.98), as opposed to hummocks (mean: 104.56 $\mu\text{m} \pm 13.03$).

Phylogenetic analysis

We added our 14 new COI sequences from individual *H. papilio* cells to the 301 sequences of Heger et al. (2013). The topologies of both the strict consensus ML and Bayesian trees were identical and showed that these sequences could all be attributed to two of the 12 lineages of Heger et al. (2013): Six sequences from cells with three or four pores were grouped into haplotype A and eight sequences from cells with two to five pores belonged to haplotype J in Heger et al. (2013); and being thus relatively distantly related. Cluster analyses of the morphometric measurements of these 14 shells using the same approach as described above did not reveal any pattern congruent with the phylogenetic tree. Therefore, our phylogenetic reconstructions showed no correlation between taxonomic positions and pore numbers or other morphological traits (Fig. 7).

DISCUSSION

Pore number in *Hyalosphenia papilio* shells

The mesocosm study showed that the average number of pores of *Hyalosphenia papilio* increased in wetter conditions, whilst specimens with more than two pores tended to disappear from the driest plots. This shift occurred abruptly and may have been initiated by warm and dry conditions during the first summer. However, it was impossible to detect a significant response of pore number to water table in the field observational study, regardless of the studied period (annual or by sampling date).

The precise function of pores in *H. papilio* is not known. Pores possibly allow water flow between the TA shell interior and the external environment (Leidy 1879). A reduced number of pores would limit such flow. This may be advantageous under drier conditions when the thickness of the water film surrounding the TA shell is reduced. As such, reduced pore number might reduce the risk of desiccation, and could be interpreted as an adaptive response of TA to drought. In a microsite where the water film thickness changes fast, a reduced number of pores could be especially advantageous by representing an adaptation to the driest conditions regularly experienced by the amoebae. This may explain why, in the within-peatland natural gradient study Linje mire, we observed fewer pores in the sites where oscillations of water table depth were greatest. This suggests that pore number and possibly other morphological traits are determined not only by the average values of ecological factors but also by their range of variation.

The change in pore number we observed in the mesocosm experiment could be seen as evidence for phenotypic plasticity. However it remained possible that different genetic species with different pore numbers co-occurred in our initial community and that the shift we observed was due to a shift in community composition among closely related but morphologically distinct pseudo-cryptic taxa. To clarify this point, a genetic study was thus necessary. Our barcoded specimens fell within the two clades observed in Western Europe by Heger et al. (2013), clades A and J. Whilst the two-pored and five-pored types were represented only in lineage J, shells with three and four pores were found in both lineages. Shell morphology did not correlate either with affiliation to clade A or J. These results suggest that neither shell dimensions and shape, nor pore number are genetically determined. This is perhaps surprising given the fact that clades A and J are distantly related within the *H. papilio* species complex and would therefore be expected to exhibit more morphological differences than two more closely-related clades.

Booth & Meyers (2010) recorded a wider range of pore numbers but their study included the broadest range of natural conditions where *H. papilio* can be found. Taken together, the results from both studies would suggest the existence of both phenotypic plasticity and genetic determinism. It is indeed likely that more clades - some of which possibly have a genetically determined higher number of pores - were included in the broader range of conditions sampled by Booth & Meyers (2010). Alternatively the morphotypes with higher pore numbers may only occur in very specific conditions (bog pools) that do not correspond to the wettest treatment in our manipulative experiment.

***Hyalosphenia papilio* shell size**

Over a one year period, we observed a clear reduction in TA shell size in the mesocosm experiment, while the effect of water table depth, although significant, was comparatively weaker. Specimens originated from a wet *Sphagnum* carpet sampled at ca. 1000m a.s.l. At the time of sampling the amoebae had spent one year in the mesocosms under very different climatic conditions at ca. 500 m a.s.l. (i.e. ca. 28% less rain - 1800 mm vs. 1500 mm - and ca. 1.5 °C warmer on average). The observed size shift therefore suggests a possible response to climate, and specifically the warmer conditions at the experimental site. This result disagrees with observations made on freshwater heterotrophic amoeboid organisms taken as a whole, for which no clear correlation between temperature and biovolume was identified (Atkinson et al. 2003). However, "naked amoebae" are a polyphyletic assemblage of a large diversity of organisms which do not share common ecology (Pawlowski & Burki 2009) and can be

Accepted Article

expected to respond differently to temperature changes. Atkinson and colleagues (Atkinson et al. 2003) proposed that higher temperatures increase metabolism in protists. Reduced size increases the contact surface with the environment relative to the biovolume. Consequently, a reduction in size as a response to increased temperature, could therefore be a mechanism for TA to deal with temperature induced metabolism. This prediction has been confirmed in cells from phytoplankton blooms, where increased temperature reduced the cell size (Sommer & Lengfellner 2008). In the case of the mixotrophic *H. papilio*, CO₂ input is not directly beneficial to host cells but to the *Chlorella* symbionts that are enclosed within. A reduction in amoeba size should increase symbionts' access to CO₂ and enhance their photosynthesis. As symbionts are responsible for a substantial part of *H. papilio* carbon input (Jassey et al. 2012; Jassey et al. 2015) a reduction in amoeba size under warmer conditions may be indirectly beneficial. This pattern is in agreement with the temperature-organism size rules, which have been widely documented in ectothermic animals (Atkinson, 1994). Besides temperature, cells were significantly smaller in the wetter treatment Fig 4. Again this may be an adaptive response to a thinner water film.

Our study in mesocosms covered only a limited period in time, and spanned a limited temperature gradient, and results can be expected to vary in a larger, *in situ* setting. As in the mesocosm study, in the survey at European scale, smaller specimens were observed in drier microhabitats (i.e. hummocks; ANOVA, microhabitat nested in site, $p < 0.05$), in agreement with the reduction in shell length at T4 in the low water table treatment. However biovolume was correlated positively to the temperature of the coldest quarter and isothermality (accounting respectively for 12% and 11% of explained variance), and negatively with variables representing instability (mean diurnal temperature range, annual temperature range). As for pores, it seems that the mean environmental condition is less critical than its magnitude of fluctuation for *H. papilio* biovolume (supp3). The contrasting correlation with temperature between the study at the European scale and the mesocosms suggests that other factors such as food quality and availability, selective pressure from predators etc., likely influence the biovolume of *H. papilio*. Such effects would be in line with modeling studies showing that an organism's size is also constrained by its position in the food web (Loeuille & Loreau 2005). To summarize, although our data show diverse and complex morphological variability, it does not allow the derivation of general temperature--size rules. More experimental data would be necessary to achieve this.

Moreover, a significant part of size variations observed on the European study could not be attributed either to climate or geography, as 52% of the biovolume variance remained unexplained. It is very likely that other factors such as nutrient availability, DOC, pH, etc. contribute widely to size variations on *H. papilio*. However, the present study does not allow investigating the effects of physical and chemical parameters on *H. papilio* biovolume (see Methods). Other experimental study would therefore be necessary to disentangle the subsequent effects of the whole panel of abiotic factors on *H. papilio* size variability.

Which rule to model protists size shift?

The results demonstrate that the morphology of *H. papilio* can vary over space and time in response to changes in its habitat. Such patterns could be due to within population changes (population size-shift hypothesis - i.e. James' rule) or to community changes (species shift hypothesis - i.e. Bergman's rule) (Daufresne et al. 2009). Our results clearly show that the variability in pore numbers as well as size is driven by phenotypic plasticity, and not pseudo-

cryptic genetic diversity. This supports the population size--shift hypothesis despite the fact that the *H. papilio* populations of the mesocosms included two genetically divergent (i.e. cryptic) species. If the population size-shift hypothesis (James' rule) is accepted, two further hypotheses could explain the changes: 1) an increase in the proportion of juvenile stages (i.e. population age-structure shift hypothesis) and 2) a shift in size at a given age (size-at-age shift hypothesis) (Daufresne et al. 2009). These latter two hypotheses can only be tested in organisms that show developmental stages or that grow as they age, which is probably not the case in TA. Shifts in shell size can thus be hypothesised to occur during cell formation, and our data suggest that such shifts could be driven by environmental conditions.

Implications for testate amoebae taxonomy, biodiversity assessment and biogeography

Our data for *Hyalosphenia papilio* show one example where testate amoeba display morphological variation that is not correlated to genetic diversity, or at least where morphology is more influenced by external factors than by genetic inheritance *per se*. Parameters such as temperature and water table depth (i.e. water film thickness around the cells) are correlated with morphological traits, which suggests that variation in morphology does not occur at random but is an adaptation to environmental conditions. Other examples of rapid morphological changes that are the product of phenotypic plasticity have been documented in other Arcellinida: *Cucurbitella tricuspis* and *Cyclopyxis kahli* (Medioli et al. 1987; Wanner 1999). This contrast with observations that small morphological differences can be used to separate species, a situation called "pseudo-cryptic diversity", which prevails among many species of protozoa and microalgae (Sáez et al. 2003; Morard et al. 2009), including arcellinid testate amoebae (Gomaa et al. 2015) and even close relatives of *Hyalosphenia papilio* (Kosakyan et al. 2013). Therefore, the relative contribution of genetic inheritance and phenotypic plasticity in shaping morphology varies depending on the taxonomic group and the trait under consideration. Thus, our data call for a reassessment of taxonomy based on morphology alone. A substantial increase in taxonomic research on these globally still under-studied organisms is clearly needed. This will quite likely lead to a re-evaluation of the classical works.

ACKNOWLEDGMENTS

This research was supported by the Ministry of Science and Higher Education, Republic of Poland, grant no. NN306060940. We acknowledge support from grant PSPB-013/2010 from Switzerland through the Swiss Contribution to the enlarged European Union. European samples were collected as part of the EU FP6 BiodivERsA (ERA-NET) project PEATBOG through NWO-ALW (grant 832.09.003) in the Netherlands and NERC in the UK. RJP acknowledges support from the Russian Scientific Fund (14-14-00891).

Authors wish to acknowledge Sandra Słowińska, Michał Słowiński, André-Laurent Perruchoud, Saskia Leopizzi, André Villard, Lauren Kroll, and Amandine Pillonel for their help in conducting this study.

AUTHOR'S CONTRIBUTIONS

MM conceived the study (mesocosm experiment conception and monitoring), carried out laboratory analysis, phylogenetic analysis, statistical analysis, and drafted the manuscript. **KM** carried out field sampling, laboratory analysis, drafted and edited the manuscript. **AK** carried out the molecular work in laboratory and edited the manuscript. **ML** is the PI of CLIMPEAT project, designed and set up the polish field experiment. **EL** contributed to the writing, editing, and phylogenetic analysis. **BJMR** collected samples for the european study, and edited the manuscript. **RJP** is the co-advisor of **LG**, participated thoroughly in the manuscript editing. **LG** processed all the samples of the European survey, and contributed to editing. **EADM** is PI on the CLIMPEAT project, conceived the mesocosm experiment, wrote and edited the draft.

LITERATURE CITED

- Atkinson, David. 1994. Temperature and Organism Size - A Biological Law for Ectotherms? *Adv. Ecol. Res.*, edited by M. Begon and A. H. Fitter, 25:1-58. Academic Press. <http://www.sciencedirect.com/science/article/pii/S0065250408602123>.
- Atkinson, David, Benjamin J Ciotti & David J. S. Montagnes. 2003. Protists Decrease in Size Linearly with Temperature: Ca. 2.5% Degrees C(-1). *Proc. R. Soc. B* 270 (1533): 2605-11. doi:10.1098/rspb.2003.2538.
- Bartual, Ana, J. Angel Gálvez & Fernando Ojeda. 2008. Phenotypic Response of the Diatom *Phaeodactylum Tricornutum* Bohlin to Experimental Changes in the Inorganic Carbon System. *Bot. Mar.* 51 (5). doi:10.1515/BOT.2008.047.
- Baur, Hannes, Yvonne Kranz-Baltensperger, Astrid Cruaud, Jean-Yves Rasplus, Alexander V. Timokhov & Vladimir E. Gokhman. 2014. Morphometric Analysis and Taxonomic Revision of *Anisopteromalus* Ruschka (Hymenoptera: Chalcidoidea: Pteromalidae) - an Integrative Approach. *Syst. Entomol.* 39 (4): 691-709. doi:10.1111/syen.12081.
- Baur, Hannes & Christoph Leuenberger. 2011. Analysis of Ratios in Multivariate Morphometry. *Syst. Biol.* 60 (6): 813-25. doi:10.1093/sysbio/syr061.
- Bobrov, Anatoly A. Sergei B. Yazvenko & Barry G. Warner. 1995. Taxonomic and Ecological Implications of Shell Morphology of 3 Testaceans (protozoa, Rhizopoda) in Russia and Canada. *Arch. Protistenkunde* 145 (1-2): 119-26.
- Bobrov, Anatoly A. & Yuri. Mazei. 2004. Morphological Variability of Testate Amoebae (Rhizopoda : Testacealobosea : Testaceafilosea) in Natural Populations. *Acta Protozool.* 43 (2): 133-46.
- Booth, Robert. K. 2002. Testate Amoebae as Paleoindicators of Surface-Moisture Changes on Michigan Peatlands: Modern Ecology and Hydrological Calibration. *J. Paleolimnol.* 28 (3): 329-48. doi:10.1023/A:1021675225099.
- Booth, Robert K. 2008. Testate Amoebae as Proxies for Mean Annual Water-Table Depth in Sphagnum-Dominated Peatlands of North America. *J. Quaternary Sci.* 23 (1): 43-57. doi:10.1002/jqs.1114.

- Booth, Robert K & Blaze Meyers. 2010. Environmental Controls on Pore Number in *Hyalosphenia Papilio*: Implications for Paleoenvironmental Reconstruction. *Acta Protozool.* 49 (1): 29-35.
- Borcard, Daniel & Pierre Legendre. 2002. All-Scale Spatial Analysis of Ecological Data by Means of Principal Coordinates of Neighbour Matrices. *Ecol. Modell.* 153 (1-2): 51-68. doi:10.1016/S0304-3800(01)00501-4.
- Calcagno, Vincent & Claire de Mazancourt. 2010. Glmulti: An R Package for Easy Automated Model Selection with (Generalized) Linear Models. *J Stat Softw.* 34 (12): 1-29.
- Chambers, John. M. & Trevor. J. Hastie. 1991. *Statistical Models in S*. New Ed. Chapman and Hall/CRC.
- Charman, Dan J. 2001. Biostratigraphic and Palaeoenvironmental Applications of Testate Amoebae. *Quat. Sci. Rev.* 20 (16-17): 1753-1764. doi:10.1016/s0277-3791(01)00036-1.
- Charman, Dan J & Barry G. Warner. 1992. Relationship Between Testate Amebas (protozoa, Rhizopoda) and Microenvironmental Parameters on a Forested Peatland in Northeastern Ontario *Can. J. Zool.* 70 (12): 2474-82. doi:10.1139/z92-331.
- Charrière, Florian, Nicolas Pavillon, Tristan Colomb, Christian Depeursinge, Thierry J. Heger, Edward A D. Mitchell, Pierre Marquet & Benjamin Rappaz. 2006. Living Specimen Tomography by Digital Holographic Microscopy: Morphometry of Testate Amoeba. *Opt Express* 14 (16): 7005-13.
- Chatelain, Auriel P., Ralf Meisterfeld, Ludovic Roussel-Delif & Enrique Lara. 2013. Sphenoderiidae (fam. Nov.), a New Clade of Euglyphid Testate Amoebae Characterized by Small, Round Scales Surrounding the Aperture. *Protist* 164 (6): 782-92. doi:10.1016/j.protis.2013.08.001.
- Chomczynski, Piotr & Nicoletta Sacchi. 1987. Single-Step Method of RNA Isolation by Acid Guanidinium Thiocyanate-Phenol-Chloroform Extraction. *Anal. Biochem.* 162 (1): 156-59. doi:10.1006/abio.1987.9999.
- Corno, Gianluca & Klaus. Jurgens. 2006. Direct and Indirect Effects of Protist Predation on Population Size Structure of a Bacterial Strain with High Phenotypic Plasticity. *Appl. Environ. Microbiol.* 72 (1): 78-86. doi:10.1128/AEM.72.1.78-86.2006.
- Daufresne, Martin, Kathrin Lengfellner & Ulrich Sommer. 2009. Global Warming Benefits the Small in Aquatic Ecosystems. *Proc. Natl. Acad. Sci. U.S.A.* 106 (31): 12788-93. doi:10.1073/pnas.0902080106.
- Edgar, Robert C. 2004. MUSCLE: Multiple Sequence Alignment with High Accuracy and High Throughput. *Nucleic Acids Res.* 32 (5): 1792-97. doi:10.1093/nar/gkh340.
- Forster, Jack, Andrew G. Hirst & Genoveva F. Esteban. 2013. Achieving Temperature-Size Changes in a Unicellular Organism. *ISME J.* 7 (1): 28-36. doi:10.1038/ismej.2012.76.
- Gilbert, Daniel & Edward A. D. Mitchell. 2015. Microbial Diversity in Sphagnum Peatlands. *Peatlands: Evolution and Records of Environmental and Climatic Changes*, no. 9 (February).
- Gomaa, Fatma, Anush Kosakyan, Thierry J. Heger, Daniele Corsaro, Edward A D. Mitchell & Enrique Lara. 2014. One Alga to Rule Them All: Unrelated Mixotrophic Testate Amoebae

(Amoebozoa, Rhizaria and Stramenopiles) Share the Same Symbiont (Trebouxiophyceae). *Protist* 165 (2): 161-76. doi:10.1016/j.protis.2014.01.002.

Gomaa, Fatma, Milcho Todorov, Thierry J. Heger, Edward A D. Mitchell & Enrique Lara. 2012. SSU rRNA Phylogeny of Arcellinida (Amoebozoa) Reveals That the Largest Arcellinid Genus, *Diffugia* Leclerc 1815, Is Not Monophyletic. *Protist* 163 (3): 389-99. doi:10.1016/j.protis.2011.12.001.

Gomaa, Fatma, Jun Yang, Edward A. D. Mitchell, Wen-Jing Zhang, Zheng Yu, Milcho Todorov & Enrique Lara. 2015. Morphological and Molecular Diversification of Asian Endemic *Diffugia Tuberspinifera* (Amoebozoa, Arcellinida): A Case of Fast Morphological Evolution in Protists? *Protist* 166 (1): 122-30. doi:10.1016/j.protis.2014.11.004.

Grbic, Djordje, Suzanne V. Saenko, Toky M. Randriamoria, Adrien Debry, Achille P. Raselimanana & Michel C. Milinkovitch. 2015. Phylogeography and Support Vector Machine Classification of Colour Variation in Panther Chameleons. *Mol. Ecol.* doi:10.1111/mec.13241.

Grömping, Ulrike. 2006. Relative Importance for Linear Regression in R : The Package Relaimpo. *J Stat Softw* 17 (1). doi:10.18637/jss.v017.i01.

Hall, Thomas A. 1999. BioEdit: A User-Friendly Biological Sequence Alignment Editor and Analysis Program for Windows 95/98/NT. *Nucleic Acids Symp Ser (Oxf)* 41: 95-98.

Hebert, Paul D. N., Erin H. Penton, John M. Burns, Daniel H. Janzen & Winnie Hallwachs. 2004. Ten Species in One: DNA Barcoding Reveals Cryptic Species in the Neotropical Skipper Butterfly *Astraptes Fulgerator* *Proc. Natl. Acad. Sci. U.S.A.* 101 (41): 14812-17. doi:10.1073/pnas.0406166101.

Heger, Thierry J., Edward A. D. Mitchell & Brian S. Leander. 2013. Holarctic Phylogeography of the Testate Amoeba *Hyalosphenia Papilio* (Amoebozoa: Arcellinida) Reveals Extensive Genetic Diversity Explained More by Environment than Dispersal Limitation. *Mol. Ecol.*, September. doi:10.1111/mec.12449.

Heger, Thierry J., Jan Pawlowski, Enrique Lara, Brian S. Leander, Milcho Todorov, Vassil Golemansky & Edward A D. Mitchell. 2011. Comparing Potential COI and SSU rDNA Barcodes for Assessing the Diversity and Phylogenetic Relationships of Cyphoderiid Testate Amoebae (Rhizaria: Euglyphida). *Protist* 162 (1): 131-41. doi:10.1016/j.protis.2010.05.002.

Heger, Thierry. J., Edward . A. D. Mitchell, Pieter Ledeganck, Sofie Vincke, Bart Van de Vijver & Louis Beyens. 2009. The Curse of Taxonomic Uncertainty in Biogeographical Studies of Free-Living Terrestrial Protists: A Case Study of Testate Amoebae from Amsterdam Island. *J. Biogeogr.* 36 (8): 1551-60. doi:10.1111/j.1365-2699.2009.02094.x.

Hijmans, Robert. J., Susan. E. Cameron, Juan. L. Parra, Peter. G. Jones & Andy. Jarvis. 2005. Very High Resolution Interpolated Climate Surfaces for Global Land Areas. *Int. J. Climatol.* 25 (15): 1965-78. doi:10.1002/joc.1276.

Jarvis, Andy, Hannes Isaak Reuter, Andrew Nelson & Edward Guevara. 2008. Hole-Filled SRTM for the Globe Version 4. Available from the CGIAR-CSI SRTM 90m Database (<http://srtm.csi.cgiar.org>).

Jassey, Vincent E J., Daniel Gilbert, Philippe Binet, Marie-Laure Toussaint & Geneviève Chiapusio. 2011. Effect of a Temperature Gradient on Sphagnum Fallax and Its Associated Living Microbial Communities: A Study under Controlled Conditions. *Can J Microbiol* 57 (3): 226-35. doi:10.1139/W10-116.

Jassey, Vincent E J., Satoshi Shimano, Christine Dupuy, Marie-Laure Toussaint & Daniel Gilbert. 2012. Characterizing the Feeding Habits of the Testate Amoebae Hyalosphenia Papilio and Nebela Tincta along a Narrow 'Fen-Bog' Gradient Using Digestive Vacuole Content and 13C and 15N Isotopic Analyses. *Protist* 163 (3): 451-64. doi:10.1016/j.protis.2011.07.006.

Jassey, Vincent E. J., Constant Signarbieux, Stephan Hättenschwiler, Luca Bragazza, Alexandre Buttler, Frédéric Delarue, Bertrand Fournier, et al. 2015. An Unexpected Role for Mixotrophs in the Response of Peatland Carbon Cycling to Climate Warming. *Sci. Rep.* 5 (November): 16931. doi:10.1038/srep16931.

Kooistra, Wiebe H. C. F., Diana Sarno, David U. Hernández-Becerril, Philipp Assmy, Carmen Di Prisco & Marina Montesor. 2010. Comparative Molecular and Morphological Phylogenetic Analyses of Taxa in the Chaetocerotaceae (Bacillariophyta). *Phycologia* 49 (5): 471-500. doi:10.2216/09-59.1.

Kosakyan, Anush, Fatma Goma, Edward A D. Mitchell, Thierry J. Heger & Enrique Lara. 2013. Using DNA-Barcoding for Sorting out Protist Species Complexes: A Case Study of the Nebela Tincta-Collaris-Bohemica Group (Amoebozoa; Arcellinida, Hyalospheniidae). *Eur. J. Protistol.* 49 (2): 222-37. doi:10.1016/j.ejop.2012.08.006.

Kosakyan, Anush, Thierry J. Heger, Brian S. Leander, Milcho Todorov, Edward A D. Mitchell & Enrique Lara. 2012. COI Barcoding of Nebelid Testate Amoebae (Amoebozoa: Arcellinida): Extensive Cryptic Diversity and Redefinition of the Hyalospheniidae Schultze. *Protist* 163 (3): 415-34. doi:10.1016/j.protis.2011.10.003.

Lamarre, Alewandre, Gabriel Magnan, Michelle Garneau & Etienne Boucher. 2013. A Testate Amoeba-Based Transfer Function for Paleohydrological Reconstruction from Boreal and Subarctic Peatlands in Northeastern Canada. *Quat. Int.* 306 (September): 88-96. doi:10.1016/j.quaint.2013.05.054.

Leidy, Joseph. 1879. *Fresh-Water Rhizopods of North America* by Joseph Leidy. Washington : G.P.O.,. <http://www.biodiversitylibrary.org/bibliography/39676>.

Loeuille, Nicolas & Michel Loreau. 2005. Evolutionary Emergence of Size-Structured Food Webs. *Proc. Natl. Acad. Sci. U.S.A.* 102 (16): 5761-66. doi:10.1073/pnas.0408424102.

Mann, David G. 2010. Discovering Diatom Species: Is a Long History of Disagreements about Species-Level Taxonomy Now at an End? *Plant Ecol Evol.* 143 (3): 251-64. doi:10.5091/plecevo.2010.405.

Marcisz, Katarzyna, Bertrand Fournier, Daniel Gilbert, Mariusz Lamentowicz & Edward A D. Mitchell. 2014. Response of Sphagnum Peatland Testate Amoebae to a 1-Year Transplantation Experiment along an Artificial Hydrological Gradient. *Microb. Ecol.* 67 (4): 810-18. doi:10.1007/s00248-014-0367-8.

Marcisz, Katarzyna, Lukasz Lamentowicz, Sandra Slowinska, Michal Slowinski, Witold Muszak & Mariusz Lamentowicz. 2014. Seasonal Changes in Sphagnum Peatland Testate

- Amoeba Communities along a Hydrological Gradient. *Eur. J. Protistol.* 50 (5): 445-55. doi:10.1016/j.ejop.2014.07.001.
- Medioli, Franco. S., David. B. Scott & B. H. Abbott. 1987. A Case Study of Protozoan Intraclonal Variability; Taxonomic Implications. *J. Foraminiferal Res.* 17 (1): 28-47. doi:10.2113/gsjfr.17.1.28.
- Medlin, Linda & Adriana Zingone. 2007. A Taxonomic Review of the Genus *Phaeocystis*. *Biogeochemistry* 83 (1-3): 3-18. doi:10.1007/s10533-007-9087-1.
- Mitchell, Edward. A. D., Alexandre. J. Buttler, Barry. G. Warner & J. M. Gobat. 1999. Ecology of Testate Amoebae (Protozoa : Rhizopoda) in Sphagnum Peatlands in the Jura Mountains, Switzerland and France. *Ecoscience* 6 (4): 565-76.
- Mitchell, Edward A. D., Daniel J. Charman & Barry G. Warner. 2008. Testate Amoebae Analysis in Ecological and Paleoecological Studies of Wetlands: Past, Present and Future. *Biodivers. Conserv.* 17 (9): 2115-37. doi:10.1007/s10531-007-9221-3.
- Morard, Raphaël, Frédéric Quillévéré, Gilles Escarguel, Yurika Ujiie, Thibault de Garidel-Thoron, Richard D. Norris & Colomban de Vargas. 2009. Morphological Recognition of Cryptic Species in the Planktonic Foraminifer *Orbulina Universa*. *Mar. Micropaleontol.* 71 (3-4): 148-65. doi:10.1016/j.marmicro.2009.03.001.
- Mulot, Matthieu, André Villard, Daniel Varidel & Edward A D. Mitchell. 2015. A Mesocosm Approach to Study the Response of Sphagnum Peatlands to Hydrological Changes: Setup, Optimisation and Performance. *Mires Peat* 16 (April). <http://mires-and-peat.net/pages/volumes/map16/map1609.php>.
- Murtagh, Fionn, 1985. *Multidimensional Clustering Algorithms*. Würzburg: Springer.
- Nguyen-Viet, H., N. Bernard, E A D. Mitchell, P-M. Badot & D. Gilbert. 2008. Effect of Lead Pollution on Testate Amoebae Communities Living in Sphagnum Fallax: An Experimental Study. *Ecotoxicol. Environ. Saf.* 69 (1): 130-38. doi:10.1016/j.ecoenv.2007.02.007.
- Oliverio, Angela M., Daniel J G. Lahr, Truc Nguyen & Laura A. Katz. 2014. Cryptic Diversity within Morphospecies of Testate Amoebae (Amoebozoa: Arcellinida) in New England Bogs and Fens. *Protist* 165 (2): 196-207. doi:10.1016/j.protis.2014.02.001.
- Pawlowski, Jan & Fabien Burki. 2009. Untangling the Phylogeny of Amoeboid Protists. *The J. Eukaryot. Microbiol.* 56 (1): 16-25. doi:10.1111/j.1550-7408.2008.00379.x.
- Payne, Richard J., Mariusz Lamentowicz & Edward A. D. Mitchell. 2011. The Perils of Taxonomic Inconsistency in Quantitative Palaeoecology: Experiments with Testate Amoeba Data. *Boreas* 40 (1): 15-27.
- Payne, Richard. J. 2013. Seven Reasons Why Protists Make Useful Bioindicators. *Acta Protozool.* 3 (52).
- Poulickova, Aloisie, Petra Hajkova, Pavla Krenkova & Michal Hajek. 2004. Distribution of Diatoms and Bryophytes on Linear Transects through Spring Fens. *Nova Hedwigia* 78 (3-4): 411-24. doi:10.1127/0029-5035/2004/0078-0411.

Qin, Yangmin, Edward A. D. Mitchell, Mariusz Lamentowicz, Richard J. Payne, Enrique Lara, Yansheng Gu, Xianyu Huang & Hongmei Wang. 2013. Ecology of Testate Amoebae in Peatlands of Central China and Development of a Transfer Function for Paleohydrological Reconstruction. *J. Limnol.* 50 (3): 319-30. doi:10.1007/s10933-013-9726-6.

Ronquist, Fredrik & John. P. Huelsenbeck. 2003. MrBayes 3: Bayesian Phylogenetic Inference under Mixed Models. *Bioinformatics* 19 (12): 1572-74. doi:10.1093/bioinformatics/btg180.

Sáez, Alberto G., Ian Probert, Markus Geisen, Patrick Quinn, Jeremy R. Young & Linda K. Medlin. 2003. Pseudo-Cryptic Speciation in Coccolithophores. *Proc. Natl. Acad. Sci. U.S.A.* 100 (12): 7163-68. doi:10.1073/pnas.1132069100.

Schlegel, Martin & Ralf Meisterfeld. 2003. The Species Problem in Protozoa Revisited. *Eur. J. Protistol.* 39 (4): 349-55. doi:10.1078/S0932-4739(04)70109-1.

Schneider, Caroline A., Wayne S. Rasband & Kevin W. Eliceiri. 2012. NIH Image to ImageJ: 25 Years of Image Analysis. *Nat. Methods* 9 (7): 671-75. doi:10.1038/nmeth.2089.

Singer, David, Anush Kosakyan, Amandine Pillonel, Edward A. D. Mitchell & Enrique Lara. 2015. Eight Species in the Nebela Collaris Complex: Nebela Gimlii (Arcellinida, Hyalospheniidae), a New Species Described from a Swiss Raised Bog. *Eur. J. Protistol.* 51 (1): 79-85. doi:10.1016/j.ejop.2014.11.004.

Šlapeta, Jan, David Moreira & Purificación López-García. 2005. The Extent of Protist Diversity: Insights from Molecular Ecology of Freshwater Eukaryotes. *Proc. R. Soc. Lond. B* 272 (1576): 2073-81. doi:10.1098/rspb.2005.3195.

Slowinska, Sandra, Michal Slowinski & Mariusz Lamentowicz. 2010. Relationships between Local Climate and Hydrology in Sphagnum Mire: Implications for Palaeohydrological Studies and Ecosystem Management. *Pol. J. Environ. Stud.* 19 (4): 779-87.

Sommer, Ulrich & Kathrin Lengfellner. 2008. Climate Change and the Timing, Magnitude, and Composition of the Phytoplankton Spring Bloom. *Glob. Chang. Biol.* 14 (6): 1199-1208. doi:10.1111/j.1365-2486.2008.01571.x.

Swindles, Graeme T., David J. Charman, Helen M. Roe & Philip. A. Sansum. 2009. Environmental Controls on Peatland Testate Amoebae (Protozoa: Rhizopoda) in the North of Ireland: Implications for Holocene Palaeoclimate Studies. *J. Paleolimnol.* 42 (1): 123-40. doi:10.1007/s10933-008-9266-7.

Tamura, Koichiro, Glen Stecher, Daniel Peterson, Alan Filipinski & Sudhir Kumar. 2013. MEGA6: Molecular Evolutionary Genetics Analysis Version 6.0. *Mol. Biol. Evol.* 30 (12): 2725-29. doi:10.1093/molbev/mst197.

Trobajo, Rosa, Laia Rovira, David G. Mann & Eileen J. Cox. 2011. Effects of Salinity on Growth and on Valve Morphology of Five Estuarine Diatoms: Salinity Effects on Estuarine Diatoms. *Phycological Res.* 59 (2): 83-90. doi:10.1111/j.1440-1835.2010.00603.x.

Tuffrau, Michel, Ghislaine Fryd-Versavel, H el ene Tuffrau & Jean G enermont. 2000. Description of Euplotes Versatilis N. Sp., a Marine Tropical Ciliate Exhibiting an Unusually Extensive Phenotypic Plasticity. *Eur. J. Protistol.* 36 (4): 355-66. doi:10.1016/S0932-4739(00)80041-3.

Ujiié, Yurika & Takahiro Asami. 2014. Temperature Is Not Responsible for Left-Right Reversal in Pelagic Unicellular Zooplanktons: Intraspecific Reversals in Single-Cell Asymmetry. *J. Zool.* 293 (1): 16-24. doi:10.1111/jzo.12095.

Van den Brink, Paul J. & Capo J. F. Ter Braak. 1999. Principal Response Curves: Analysis of Time-Dependent Multivariate Responses of Biological Community to Stress. *Environ. Toxicol. Chem.* 18 (2): 138-48. DOI:10.1002/etc.5620180207

Wanner, Manfred. 1999. A Review on the Variability of Testate Amoebae: Methodological Approaches, Environmental Influences and Taxonomical Implications. *Acta Protozool.* 38 (1): 15-29.

Woodland, Wendy A., Dan J. Charman & Peter C. Sims. 1998. Quantitative Estimates of Water Tables and Soil Moisture in Holocene Peatlands from Testate Amoebae. *Holocene* 8 (3): 261-73. doi:10.1191/095968398667004497.

Wylezich, Claudia, Ralf Meisterfeld, Susanne Meisterfeld & Martin Schlegel. 2002. Phylogenetic Analyses of Small Subunit Ribosomal RNA Coding Regions Reveal a Monophyletic Lineage of Euglyphid Testate Amoebae (Order Euglyphida). *J. Eukaryot. Microbiol.* 49 (2): 108-18.

FIGURE LEGEND

Fig. 1 Morphological measurements *Hyalosphenia papilio* specimens. (a) maximum length, (b) maximum width, (c) pseudostome width, (d) orthogonal distance from the pseudostome to the maximum width axis, (e) orthogonal distance from the pseudostome side to height of the highest pore, (f) linear distance from the pseudostome side to the first encountered pore, (α) angle of the neck, (g) not measured, axis passing by the highest pores, orthogonal to (a) axis, to measure (e). The number of pores was also counted (purple arrows).

Fig. 2 Scatterplot of first against second shape Principal Component of morphometric data of 200 *Hyalosphenia papilio* individuals, from High (-4 cm) and Low (-25 cm) water table treatment at T0 and T4. The variance explained by each PC is given in parentheses. The treatments are morphologically segregated along the first axis of the PCA. }

Fig. 3 Conditional inference tree (CIT) of *Hyalosphenia papilio* specimen biovolume. The tree shows a reduction in shell length at T4 in the low water table treatment.

Fig. 4 Mean variation in pore number over time in the mesocosm experiment (left) and field study (right), respectively per habitat and treatment. Shading of points illustrates the degree of wetness (the darker the wetter).

Fig. 5 Principal Response Curve of Hellinger transformed morphotypes (pores number) abundance distribution in the mesocosm experiment by treatment (water level).

Fig. 6 Variance partitioning of *Hyalosphenia papilio* biovolume in 37 *Sphagnum* peatlands across Europe. Macroscale variables were PCNM axis 1-5, mesoscale variables were PCNM axis 7-9 and microscale variables were PCNM axis 12--16. Bioclimatic variables were altitude, annual precipitation (BIO12), mean diurnal temperature range (BIO2), isothermality (BIO3), mean temperature of the coldest month (BIO6), precipitation of the driest month

(BIO14), precipitation of the wettest month (BIO13), precipitation of the coldest quarter (BIO19), precipitation of the driest and wettest quarters (BIO17 and BIO16) and annual temperature range (BIO1). Bioclimatic variables are represented by the rectangles

Fig .7 Molecular phylogenetic analysis by Maximum Likelihood method based on the Tamura-Nei model. The tree is drawn to scale, with branch lengths measured in the number of substitutions per site. Blue numbers indicate the posterior probability of the bipartition, computed by Bayesian inference using MrBayes. Blue and red highlighting indicates the morphological cluster to which the cell belongs, computed using the MRA approach. The groups were computed based on morphological trait ratios using the Ward method on a previously obtained Euclidean dissimilarity matrix. Stars indicate the number of pores. **Top left corner:** Shape PCA of the ratios, with hull drawn over morphological clusters

Table 1 Best discriminating ratios obtained by Linear Discriminant Analysis. The best discriminating ratio between specimen of T0 and T4 are angle/L and l/pores. As angle and pores number are fairly constant between the two sampling dates, specimens are in fact discriminated by an isometric size reduction.

SUPPORTING INFORMATION

Fig. S1 Location of the Linje mire within the borders of Poland, showing the piezometers (p3, p5, p6, p7, p11) around which sampling plots in the seasonal observational study were located.

Table S2 Corresponding Bioclim variables

Table S3 ANOVA table of the effect of WTD and time (clustered as Treatment or habitat) on *Hyalopshenia papilio* individuals mean pore number. Formula : Mean pore \sim cluster + cluster/time

Table S4 Relative importance of each bioclimatic variables (+ altitude) on biovolume variations.

Table S5 Characteristics of the sequenced cells for the figure 7

Table 1 Best discriminating ratios obtained by Linear Discriminant Analysis. The best discriminating ratio between specimen of T0 and T4 are angle/L and l/pores. As angle and pores number are fairly constant between the two sampling dates, specimens are in fact discriminated by an isometric size reduction

Groups	best ratios	range T4	range T0	SD	delta
r1 T0-T4	angle/L	0.81-1.30	1.22-1.66	4.89	0.51
r2 T0-T4	l/pores	26.38-46.01	18.09-29.46	2.13	0.71

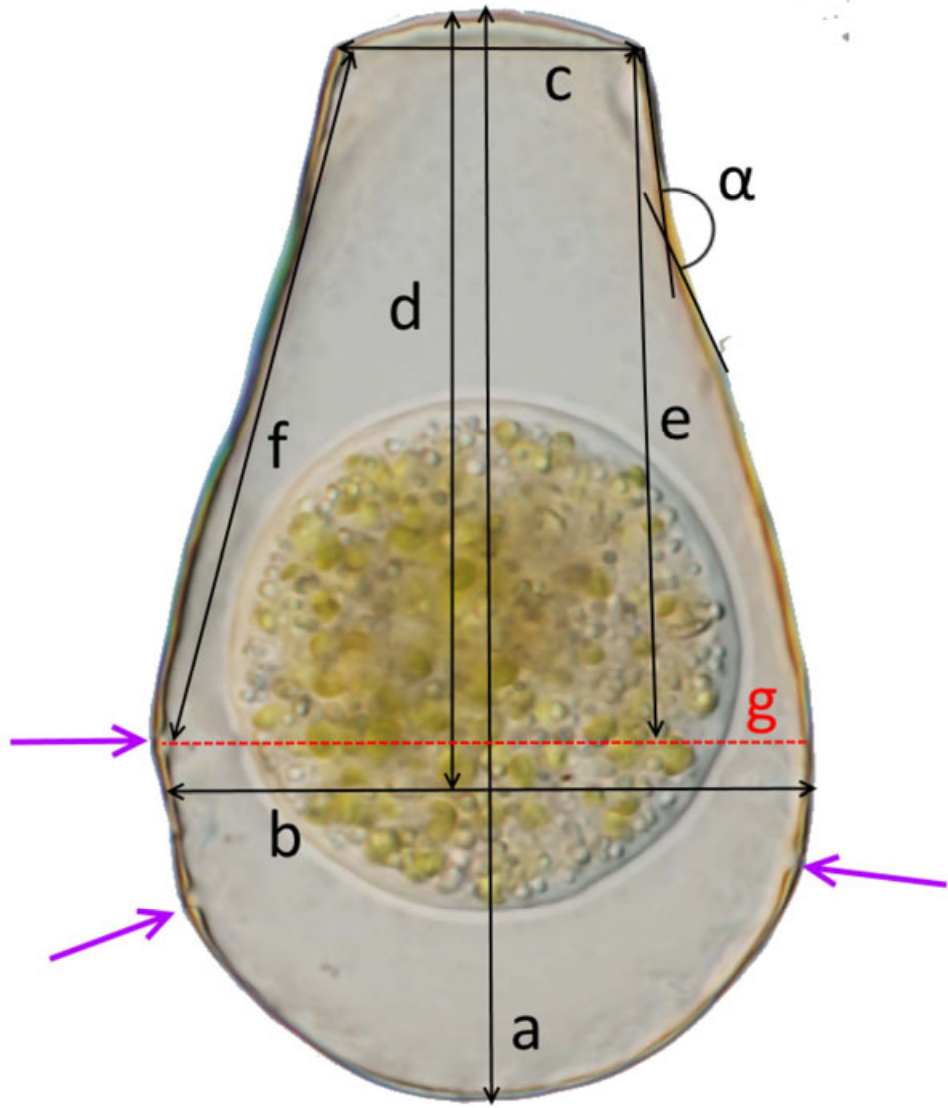

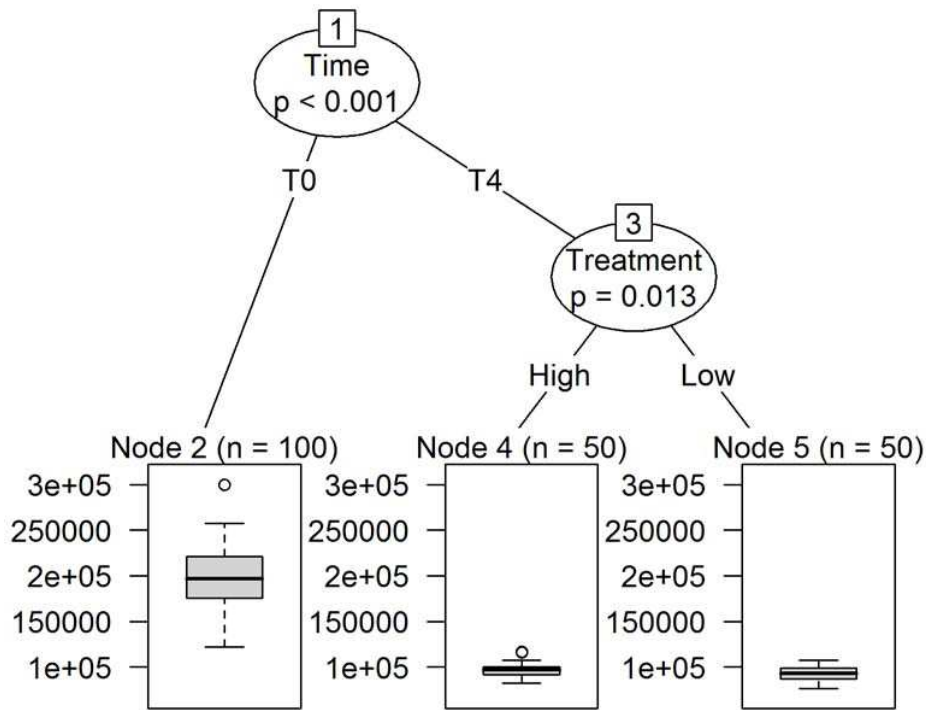
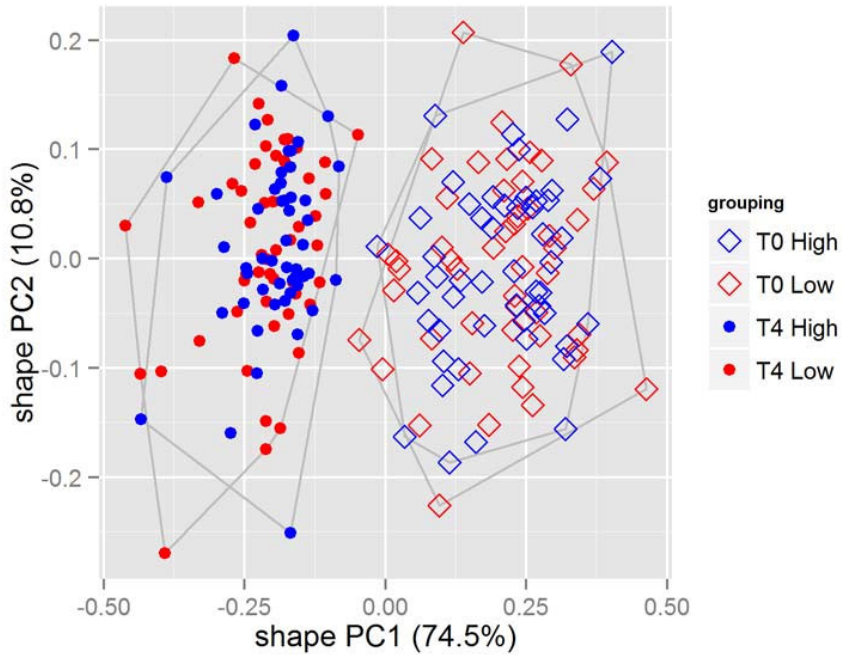

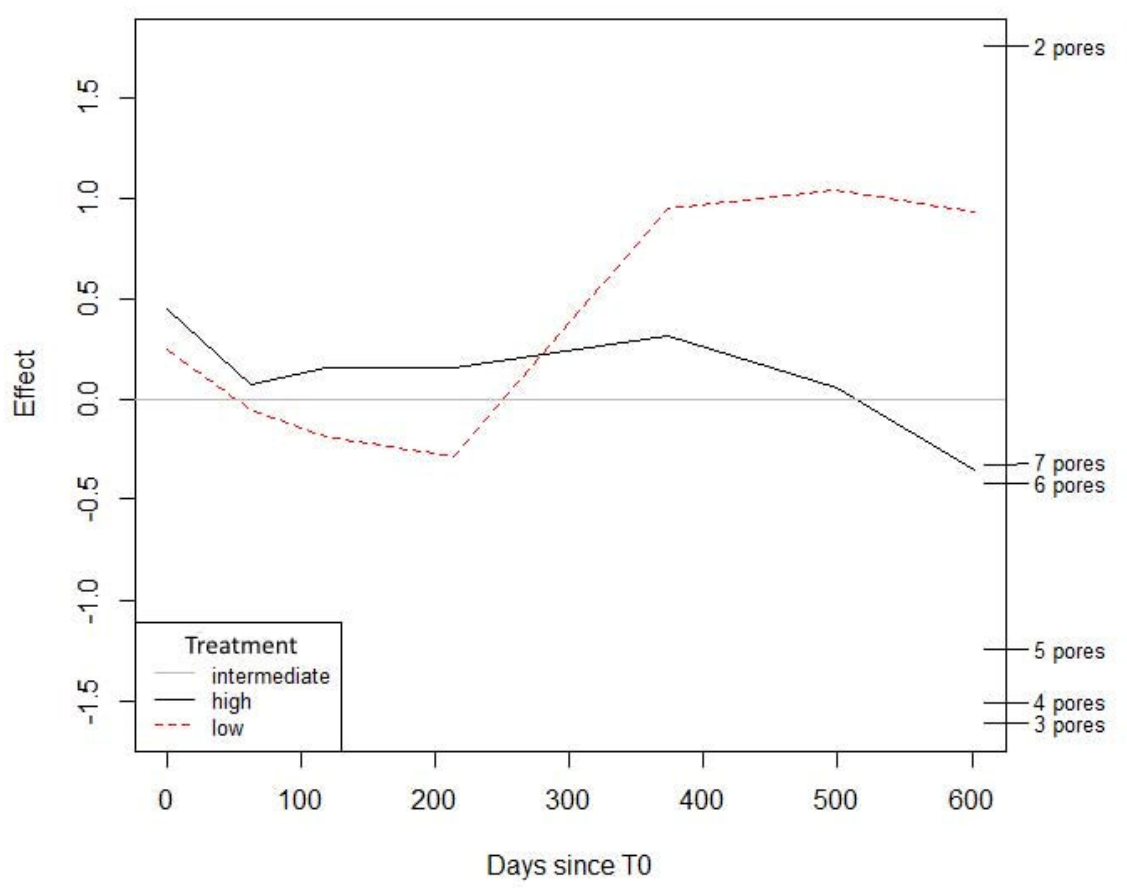
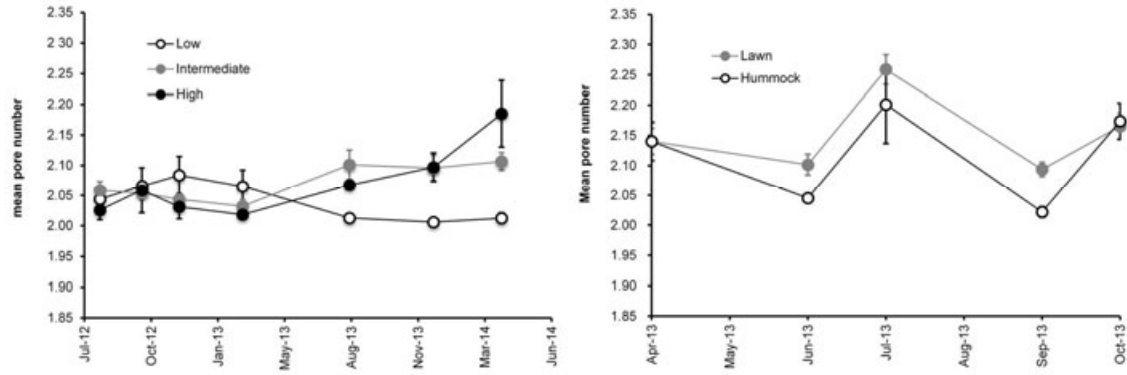

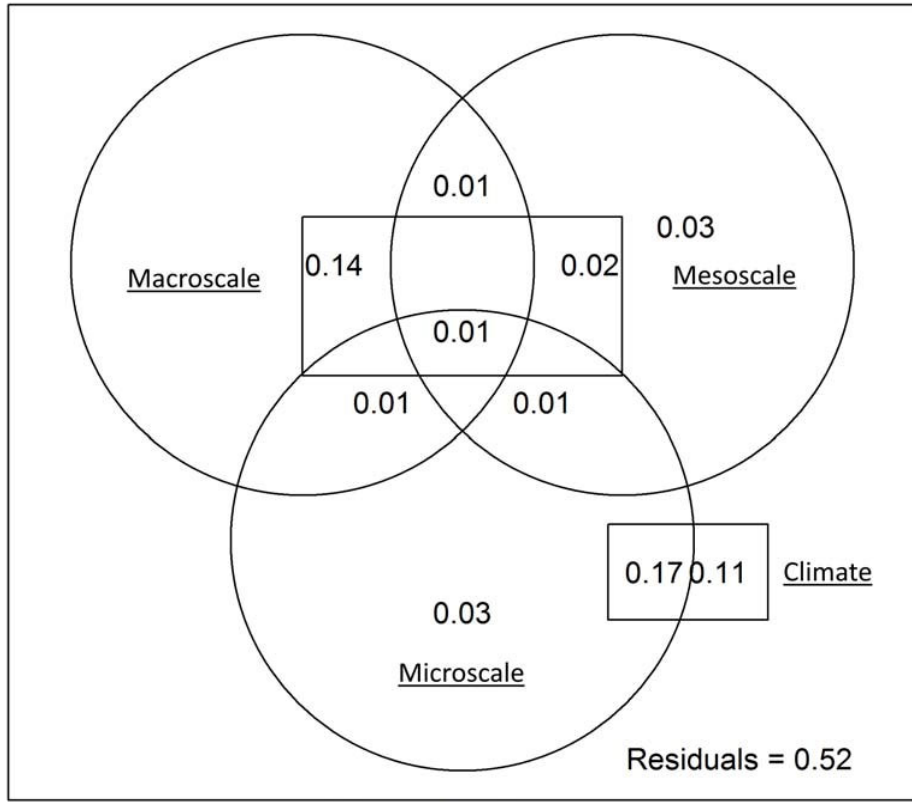

Values <0 not shown

