

Michael F. Kelly, Mark D. White, Ieuan Owen  
School of Engineering, University of Liverpool, Liverpool, UK

Steven J. Hodge  
Flight Simulation, BAE Systems, Warton Aerodrome, Preston, UK

# The Queen Elizabeth Class Aircraft Carriers: Airwake Modelling and Validation for ASTOVL Flight Simulation

## ABSTRACT

This paper outlines progress towards the development of a high-fidelity piloted flight simulation environment for the UK's Queen Elizabeth Class (QEC) aircraft carriers which are currently under construction. It is intended that flight simulation will be used to de-risk the clearance of the F-35B Lightning-II to the ship, helping to identify potential wind-speeds/directions requiring high pilot workload or control margin limitations prior to First of Class Flight Trials. Simulated helicopter launch & recovery trials are also planned for the future.

The paper details the work that has been undertaken at the University of Liverpool to support this activity, and which draws upon Liverpool's considerable research experience into simulated launch and recovery of maritime helicopters to single-spot combat ships. Predicting the unsteady air flow over and around the QEC is essential for the simulation environment; the very large and complex flow field has been modelled using Computational Fluid Dynamics (CFD) and will be incorporated into the flight simulators at the University of Liverpool and BAE Systems Warton for use in future piloted simulation trials. The challenges faced when developing airwake models for such a large ship are presented together with details of the experimental setup being prepared to validate the CFD predictions. Finally, the paper describes experimental results produced to date for CFD validation purposes and looks ahead to the piloted simulation trials of aircraft launch and recovery operations to the carrier.

## INTRODUCTION

The UK Ministry of Defence is currently embarked on the construction of the new HMS Queen Elizabeth (Fig. 1) and Prince of Wales aircraft carriers. At 65,000 tonnes each they are the largest warships ever built for the Royal Navy. The QEC carriers will be equipped with the highly augmented Advanced Short Take-Off and Vertical Landing (ASTOVL) variant of the Lockheed Martin F-35 Lightning II fighter aircraft [1]. Characteristic features of the QEC include the twin island layout, and the ramp, or "ski-jump", at the bow to facilitate short take-off. The concurrent development of the QEC and F-35 programmes presents a unique opportunity to deploy modelling & simulation to optimise the aircraft-ship interface and maximise the combined capabilities of these two assets [2].

The UK has significant legacy experience of shipborne STOVL operations, but since the retirement of the Harrier fleet from Royal Navy service its recent experience has been largely limited to rotary-wing operations, with the AgustaWestland Lynx and Merlin the primary aircraft now in use with the Surface Fleet. Landing such aircraft onto ships at sea is a task of considerable difficulty, particularly to single-spot combat ships, and modelling & simulation research at the University of Liverpool (UoL) has therefore been directed towards maximising operational capability and reducing pilot workload during helicopter launch and recovery.

Determining the safety margin and pilot workload for helicopter take-off and landing under different conditions takes place during First of Class Flight Trials (FOCFTs), allowing crews to perform a risk assessment

according to aircraft payload, sea-state, visibility, and wind speed/direction [3]. FOCFT are used to determine Ship-Helicopter Operating Limits (SHOL), which thereafter provides a guide for pilots and crew for identifying the maximum permissible limits for a given helicopter landing on a given ship deck for a range of wind speeds and directions.



Figure 1: HMS Queen Elizabeth aircraft carrier being prepared for fitting-out, as of July 2014

This paper will describe some of the current research that is taking place at UoL, working closely with BAE Systems, to create a QEC flight simulation capability for the F-35 Lightning II at Warton; QEC simulation research at UoL will concentrate on unrestricted generic ASTOVL fixed wing aircraft and maritime helicopters. The particular challenge addressed in this paper is the creation of the CFD-generated airwakes for the QEC. To set the scene and establish the importance of the airwake, the paper will first give some background into the development of simulated SHOLs for a maritime helicopter operating to a frigate, before moving on to the specific topic of the QEC airwake and its particular challenges.

SHOLs are currently determined by the Royal Navy by performing FOCFTs for each ship-helicopter combination, using test pilots to perform numerous landings in a wide range of conditions at sea. During SHOL testing, limits are determined using the Deck Interface Pilot Effort (DIPES) scale, with a rating being awarded by a test pilot for each attempted landing based on the workload experienced and an assessment of whether or not an average fleet pilot could consistently repeat the landings safely [4]. Test engineers also interpret aircraft power and control margins to inform the DIPES rating; a rating of 3 (on a scale of 1 to 5) is considered to be the limit of

safe operation for a given ship-aircraft combination, for an average fleet pilot.

Once the pilot ratings have been awarded for each wind speed, direction, and sea-state using a combination of flight testing and read-across, the completed wind envelope for a given ship-aircraft combination can be produced. The SHOL diagram illustrates the safe boundaries for each wind speed and direction at a specified Corrected All Up Mass (CAUM). Maximum permissible deck motion angles are also listed in the SHOL diagram [5].

In February 2012, flight trials were performed aboard the Type-23 frigate HMS Iron Duke to determine the SHOL for the new AgustaWestland AW159 Wildcat helicopter that was due to enter service with the Royal Navy in 2015. It was reported that test pilots performed 390 landings over two ten-day periods in a variety of conditions, which included night landings [6]. A similar set of tests will be performed for the F-35B FOCFT, to develop the equivalent of a SHOL for the Vertical Landing (VL) element of F-35B FOCFT.

The FOCFT process, while reliable, carries numerous practical difficulties and incurs considerable expense, with crews and equipment engaged for several weeks in the task of determining a SHOL for each new ship-aircraft combination. Even after several weeks at sea the desired environmental conditions might not be encountered, with crews relying upon the forecast of wind and sea-state conditions to be within reach of the ship to complete testing. Indeed, aircraft mass is often the only fully controllable variable during SHOL testing [3].

With increasing defence budget constraints facing many nations, a more cost-effective method of producing accurate SHOLs for future aircraft-ship combinations is desirable. Simulation of the aircraft-ship Dynamic Interface (DI) offers a cost-effective aid to real-world SHOL testing, with continuing improvements in simulation fidelity making this option increasingly feasible. In the US, the Joint Shipboard Helicopter Integration Process (JSHIP) Joint Test and Evaluation Force has made progress in the use of modelling and simulation to expand Wind Over Deck (WOD) flight envelopes for a range of ship/helicopter

combinations [7]. In the UK, UoL has been at the forefront of research aimed at developing high-fidelity ship-helicopter DI simulation [8]. Developments in affordable, powerful computing systems have resulted in continual improvement to the modelling of the dynamic interface. The research at UoL has also shown that a high-fidelity dynamic interface simulation can provide a better understanding of the ship-aircraft interaction, and can therefore be of benefit to future ship/aircraft design and operation [9].

Flight simulation facilities at UoL include the HELIFLIGHT-R flight simulator, which has six degrees of freedom, is driven by a Linux-based system, and has been successfully used in several previous simulation research projects [10]. External and internal views of the HELIFLIGHT-R flight simulator are shown in Fig. 2.



Figure 2: QEC visual environment in the HELIFLIGHT-R flight simulator

Simulation of the aircraft-ship dynamic interface requires effective modelling of an aircraft's flight dynamics, unsteady ship airwakes, and ship motion, with mutual dependency between these three key simulation areas. Realistic visual models are also required, including sea surface, ship geometry, deck markings, and visual landing aids.

In recent years, work has been carried out to improve the fidelity of unsteady ship airwakes in the flight simulation environment. Airwake perturbations can be applied to the aircraft flight model in the simulator using look-up tables populated by offline CFD computations of the airflow over different ship-types to produce realistic unsteady ship airwakes at a range of WOD conditions. Test pilot

comments have been “generally very good”, with pilots “report[ing] feeling the effects of turbulence in locations where it was expected” [4].

However, while the previous ship airwake research at UoL has been carried out for single-spot (i.e. frigate-size) ships, the QEC aircraft carriers are significantly larger, multi-spot platforms, with a requirement to operate both fixed-wing and rotary-wing aircraft. The increased size and complexity of the QEC airwakes necessitates a new approach to ensure the computed CFD has the required fidelity for flight simulation. This paper addresses the numerical challenges and the experimental validation required to ensure confidence in the CFD airwakes prior to their use in simulation trials.

## AIRWAKE MODELLING

### Computational fluid dynamics

To create a high fidelity simulation, a validated set of CFD airwakes will be incorporated into the flight simulators at UoL and BAE Systems Warton to re-create the effects of unsteady flow in the proximity of the landing areas and downwind of the ship. ANSYS Fluent was selected as the CFD solver, employing the DDES SST  $k-\omega$  based turbulence model with third order accuracy. This use of Large Eddy Simulation (LES) in the domain free-shear flow region offers the twin advantages of time-accurate resolution of Reynolds stresses, and reduced dissipation due to eddy viscosity when compared with a “pure” Reynolds-Averaged Navier-Stokes (RANS) approach [11].

The increased computational demands of the larger airwakes required by an aircraft carrier model have necessitated a different CFD approach to that used on smaller frigate-size ships [12]. The increased size of the QEC will immediately increase computational expense to maintain sufficient cell density in the region of the 280m×70m flight-deck. Additionally, and more significantly, the primary requirement for the aircraft carrier CFD airwake is to accurately maintain the airwake unsteadiness along the fixed-wing approach to the ship, where the aircraft will begin to experience the airwake of the carrier at up to

half a mile prior to landing [13]. The QEC CFD airwake will also be required to accommodate Vertical Landing (VL) approaches, further increasing the mesh cell count required. Previous work by the US Naval Air Systems Command (NAVAIR) has produced 7 million cell CFD grids for the 333 metre long Nimitz class USS George Washington (CVN-73), however initial efforts have found this grid density to be insufficient for a DES study on this scale [14].

## Boundary conditions

The ship CAD geometry was placed in a cylindrical domain of 4.5 ship lengths diameter, providing sufficient distance to prevent far field interference in the vicinity of the geometry or glideslope focus region. All surfaces of the aircraft carrier were modelled as zero-slip walls. The upper surface of the domain was set as a pressure-far-field, permitting flow to move vertically out of the domain, and thus minimising any potential for blockage. The sea surface was set as a wall with a slip condition, thereby allowing a prescribed inlet velocity profile to be maintained throughout the domain. The inlet velocity into the domain was modelled to reproduce the Earth's Atmospheric Boundary Layer (ABL) at sea using the logarithmic profile given in Equation 1.

$$V = V_{ref} \left( \frac{\ln\left(\frac{z}{z_0}\right)}{\ln\left(\frac{z_{ref}}{z_0}\right)} \right) \quad (1)$$

Where:  $V$  is velocity at any given height,  $z$ ,  $V_{ref}$  is the reference wind-speed measured at the ship's anemometers,  $z_{ref}$  is the ship's anemometer height, and  $z_0$  is the sea-surface roughness length scale. The reference wind speed will be the sum of the ship speed and true wind speed at anemometer height, with the ABL profile adjusted accordingly.

## Glideslope turbulence

Arguably the most significant challenge for CFD modelling of the aircraft carrier airwake is to accurately represent the turbulence in the velocity components along the fixed-wing glideslope, including in the unsteady wake of the ship through which pilots must pass during a landing. In aircraft carrier operations, this massively separated unsteady airwake region

off the stern and in the lee of the carrier is known as the "carrier burble" [15]. To accurately resolve the carrier burble, the mesh must be refined locally, resulting in a significant increase in cell count. The nominal QEC approach paths for SRVL and VL are illustrated in Fig. 3. Fixed-wing CV pilots report that the airwake can be felt up to 0.5 miles aft of the ship. Without a burble cell density region, the QEC mesh will be of the order of 30 million cells. With the burble density region included, the cell count increases to roughly 120 million cells to capture the flow detail 0.25 miles aft of the ship.

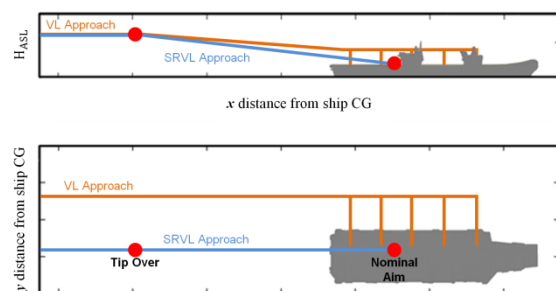

Figure 3: CFD export domain for QEC, also illustrating approaches for SRVL and VL

## Mesh generation

Preparing the ship geometry for CFD requires decisions to be made for the simplification of that geometry. The surface cell size that has been adopted is 30cm, with prism layers grown from this surface mesh. Geometry features are prepared accordingly, requiring user experience to determine where mesh problems are likely to occur. In the generation of a very large mesh, which must be carried out using High-Performance Computing (HPC), each step of mesh generation can be computationally intensive, with mesh problems difficult to rectify using a desktop computer.

For a bluff-bodied frigate or destroyer where the air flow separates from the sharp edges on the superstructure, accurately capturing wall boundary layers has little effect upon the airwake over the helicopter landing spot in the free shear region aft of the superstructure. As a result, studies have used insufficient numbers of prism layers to accurately capture boundary layer growth, with no discernible effect upon results over the flight deck [16]. However for an aircraft carrier, whose flight deck is

essentially a flat plate, the effect of boundary layer growth could have a greater impact upon the airwake over the landing spots. A requirement for a larger number of prism layers significantly increases the density of the mesh. For the QEC CFD, each additional prism layer was found to add approximately 5 million cells to the overall mesh cell-count.

### Simulation settling time

The flight simulation requires a 30 second airwake, which is then looped in the simulator; however, prior to reaching the desired 30 second sampling time, the CFD calculations must first be permitted to settle to ensure a repeatable solution. An increased ship length will result in an increased CFD simulation settling time. As an unsteady solution begins, the fluid should pass over the length of the ship several times for the flow to assume a fully unsteady state. For a 130m long frigate at a wind speed of 40kts, it will take approximately 15 seconds for the flow to pass over the ship 2.5 times. For a 280m long aircraft carrier at 25kts, it will take approximately 60 seconds for the flow to begin to achieve a settled transient solution, requiring several hours of CPU time per second of CFD simulation. The free-stream velocity can be increased to reduce settling time, provided flow remains incompressible; however it is important that the Courant-Friedrichs-Lewy (CFL) condition is obeyed across the ship, requiring a compromise between settling time and time-step in the simulation set-up [17].

Equation 2 was used to approximate the simulation settling period, where  $t_{set}$  is the settling time,  $L$  is the characteristic length over which the fluid will pass, and  $V$  is the true free-stream velocity.

$$t_{set} \approx \frac{2.5L}{V} \quad (2)$$

It should be noted that this settling time is used as a rule-of-thumb only, with actual settling time varying in practice due to a range of factors (e.g. time-step, iterations per time-step, mesh quality, boundary conditions). The total wall-clock time required per run was found to be approximately 30 days using 128 processors, depending upon settling behaviour for a given WOD.

### Post-processing data

Data size for the larger fixed-wing QEC CFD simulation should also be taken into consideration. Raw data files (containing full simulation data) are approximately 3.5TB per wind-direction. Manipulation of this data presents challenges and cannot be achieved using desktop computers. Instead, HPC must be used for data processing, placing increased demands upon shared resources. Data storage and transfer also presents challenges, with even the fastest Solid State Drives reading/writing at 550/520MB/s.

Upon completion of a CFD simulation for a given wind azimuth, the airwake velocity data must then be converted into a format which can be integrated into the flight simulator. The unstructured data is first interpolated onto a structured grid in the region of interest, before being output in ASCII format. An example structured grid can be seen in Fig. 4. The output ASCII airwake data can then be imported into the simulator's flight mechanics modelling software, where verification takes place to ensure that the airwake is correctly positioned relative to the ship's visual model in the flight simulator environment.

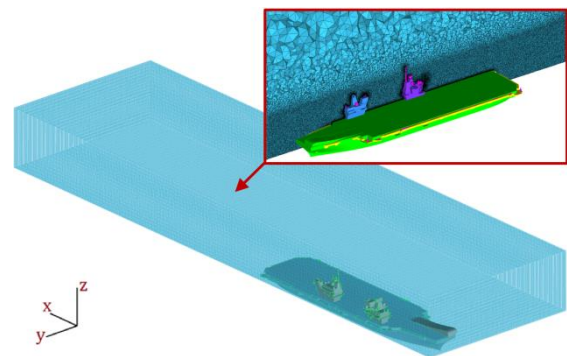

Figure 4: QEC unstructured CFD exported as a set of structured air-wake look-up tables

### QEC AIRWAKE ANALYSIS

Once the simulated airwakes have been computed for QEC, a large amount of data is output which can then be interrogated to gain a better understanding of the flow around the ship. This section gives a brief overview of some of the QEC airwake characteristics for a headwind WOD. Figure 5 shows the normalised mean of the unsteady flow over QEC at 5 metres height above deck; the figure also shows the six primary Vertical Landing

(VL) spots on the flight-deck. As can be seen, at this height the mean unsteadiness in the flow over the flight deck is dominated by the flow separating from the vertical edges of the ski-jump, and the islands. Shedding occurs from these edges, creating turbulence which

cascades along the flight deck, and through which fixed-wing and rotary-wing aircraft must pass during landing. The flow around these features is discussed in further detail below.

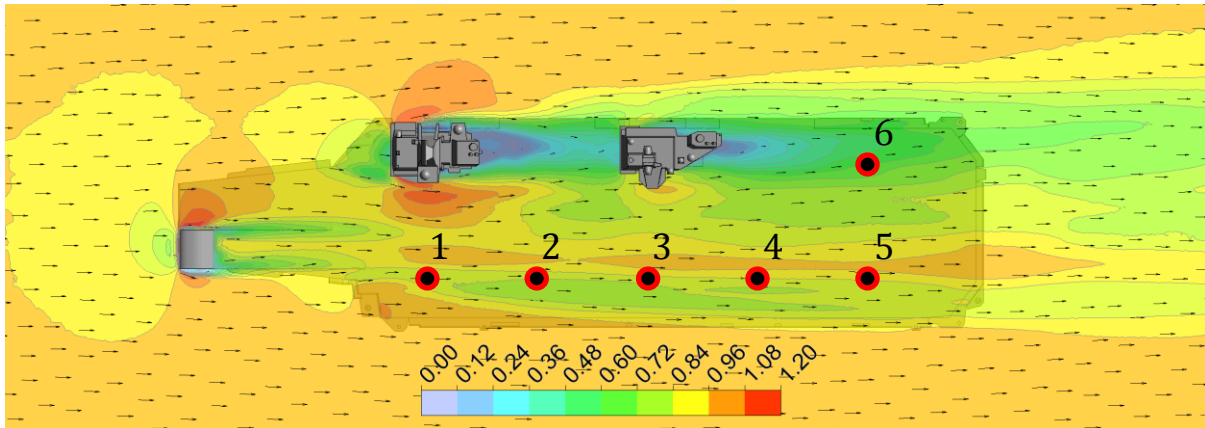

Figure 5: Mean CFD flow contours over QEC geometry, normalised by free-stream velocity. Landing spots 1-6 are indicated.

### Flow between islands

The QEC aircraft carriers are unique in that they possess twin islands, as was seen in Fig. 1. The forward island is tasked with the operation of the ship, while the aft island operates as flight control; however, each island can also perform the task of the other, providing redundancy in design and thereby increasing the survivability of the ship. Figure 6 shows the mean velocity contours and vectors over the QEC islands, normalised by free-stream velocity.

The contour plane is positioned at 24 metres towards starboard from the centreline of the ship ( $y=24m$ ). As can be seen, a reduced velocity region is present between the two

islands, resulting from combined effects of the low-pressure region immediately aft of the forward island, and the blockage of the forward face of the aft island. These effects combine to reduce mean flow velocity in this region, in addition to increased unsteadiness. Although it was outside the scope of this initial study, an aircraft lift is also positioned between the two islands, which could further complicate the airwake in this region when lowered down to hanger level. As well as having implications for aircraft operations in the wake of the islands, the gross flow disturbance could also have consequences for the accuracy of the ship's anemometers; the positions of the forward port anemometer and aft anemometer are labelled in Fig. 6.

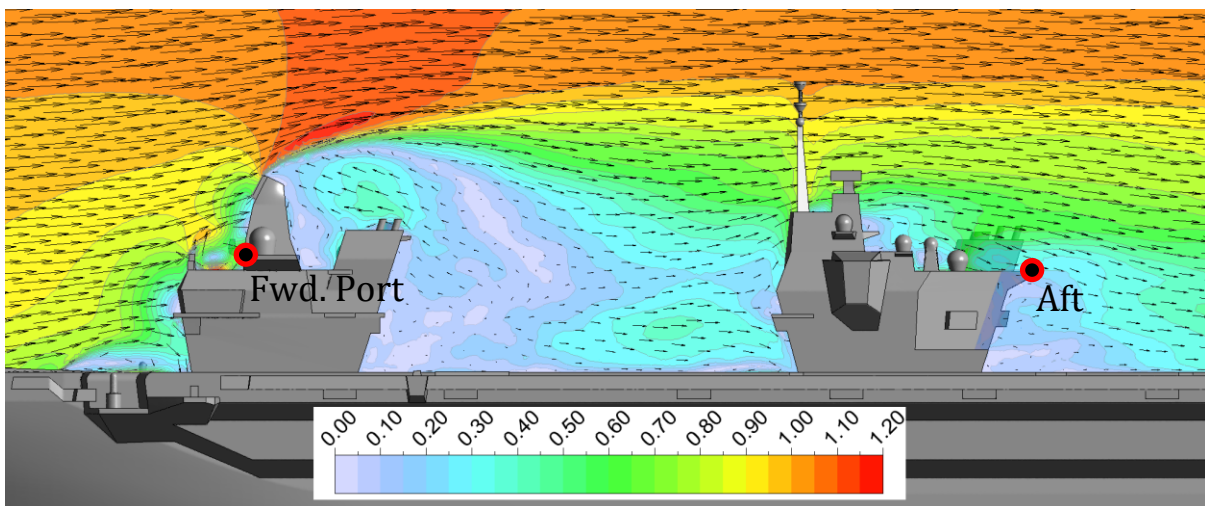

Figure 6: Mean CFD flow contours over QEC islands, normalised by free-stream velocity.

## Bow flow separation

Figure 7 shows the geometry of the QEC bow region with mean streamlines demonstrating flow behaviour over this part of the ship. As can be seen, the front face of the ship is bluff, blending into the forward face of the ski-jump, and blending into the deck starboard of the ski-jump with a rounded edge.

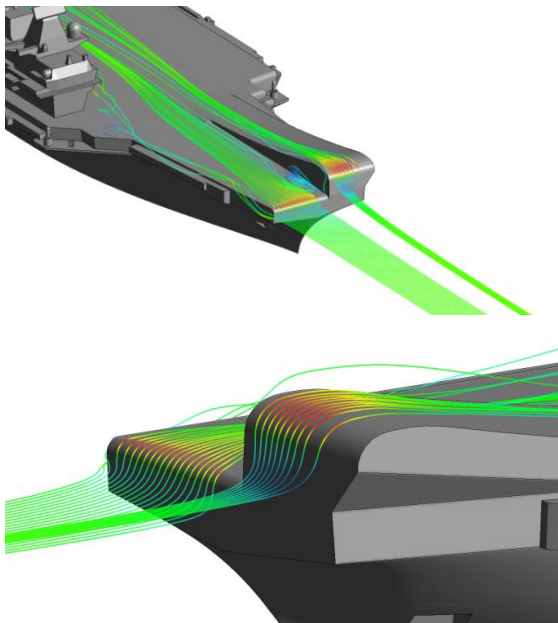

Figure 7: Views of mean streamlines over QEC rounded deck-edge

Inspection of the flow over this part of the ship shows there is minimal separation as it passes over the rounded forward deck-edge, particularly further to starboard away from the turbulence caused by the ski-jump sharp vertical edge; this initial observation is promising, as a previous study by Czerwiec and Polsky [18] outlined the importance of minimising unsteady characteristics over the bow of US Navy LHD and LHA-class ships to provide a more uniform flow-field in the vicinity of the flight deck. Czerwiec and Polsky retrofitted downward-deflected flaps over the bow of an LHA wind tunnel model in an attempt to improve flow over the sharp 90° corner found on LHA and earlier LHD-class ships.

The character of the QEC rounded deck-edge flow (i.e. whether detached or attached) is known to be dependent upon the radius of the rounded edge, and the Reynolds number [19]. As the Reynolds number decreases, the rounded edge radius must be increased to maintain attached flow [20]. For a road

vehicle, the experimental work of Cooper [19] can be used to determine that a Reynolds number (referenced to the square root of the body reference area),  $Re_A$ , of  $\sim 2.62 \times 10^6$  is required to ensure attached flow for a non-dimensionalised leading edge radius,  $r/H_{deck}$ , of 0.055, as found for the rounded forward edge of QEC (where deck height above sea level has been used as the local characteristic length). For QEC, in a 25kt headwind,  $Re_A \approx 15 \times 10^6$  in this region and so attached flow should be expected for the rounded leading radius of the QEC deck.

Another view of the smooth air flow over the rounded leading edges of the deck and the ski-jump is seen in the upper and lower images in Fig. 8. However, the centre image is in a plane that is affected by the flow separating from the vertical side of the ski jump. The flow in this region can be seen to have a recirculation zone that can also be seen in Fig. 7, and which is the cause of the turbulent region emanating from the starboard edge of the ski-jump in Fig. 5. The flow also separates from the port edge of the ski jump and passes under and around the ski-jump to be channelled along the forward port-side catwalk and onto the flight deck, as seen in Fig. 9. This turbulent flow then forms a three-dimensional vortex which "corkscrews" along the port edge of the ski-jump and along the port landing spots 1-5, shown earlier in Fig. 5.

In the analysis of this rounded forward deck-edge, it should be noted that the QEC computational grid for this work employed a non-dimensional first layer height of  $Y^+ \approx 30$ , and so the SST  $k-\omega$  turbulence model operating in the RANS region of the flow is essentially applying a  $k-\epsilon$  wall function approach in the viscous sub-layer. The  $k-\epsilon$  model is known to be robust and reliable in predicting separation from sharp-edges and free-shear flows with relatively small pressure gradients; however its accuracy has been shown to be reduced in regions of large adverse pressure gradients (e.g. in predicting separation and reattachment) [21]. To give a more accurate prediction of the separation over the QEC rounded deck-edge, it would be necessary to perform a study with a computational grid non-dimensional first layer height of  $1 < Y^+ > 2$ , thus ensuring resolution of the viscous sub-layer with the  $k-\omega$  low

Reynolds formulation of the SST turbulence model, and thereby providing a better prediction of these regions of adverse pressure gradients. However, the presence of a small 11cm gunwale lip at the top of the rounded deck-edge in addition to other features in this region which are below the minimum mesh size would require that a much finer grid be employed in addition to the further computational cost of resolving the viscous sub-layer resultant from setting a non-dimensional first layer height of  $Y^+ \leq 1$ .

The purpose of this study was to give an approximation of flow behaviour near to the ship geometry, with the primary objective of resolution of the LES resolved free shear region of the flow, far from the ship surfaces, and through which approaching aircraft will travel during flight simulation trials. For this reason, an acceptable approximation of flow very near to the QEC geometry was deemed to be sufficient for this study, with computational effort concentrated in the LES region of the grid, where the airwake was to be exported for flight simulation.

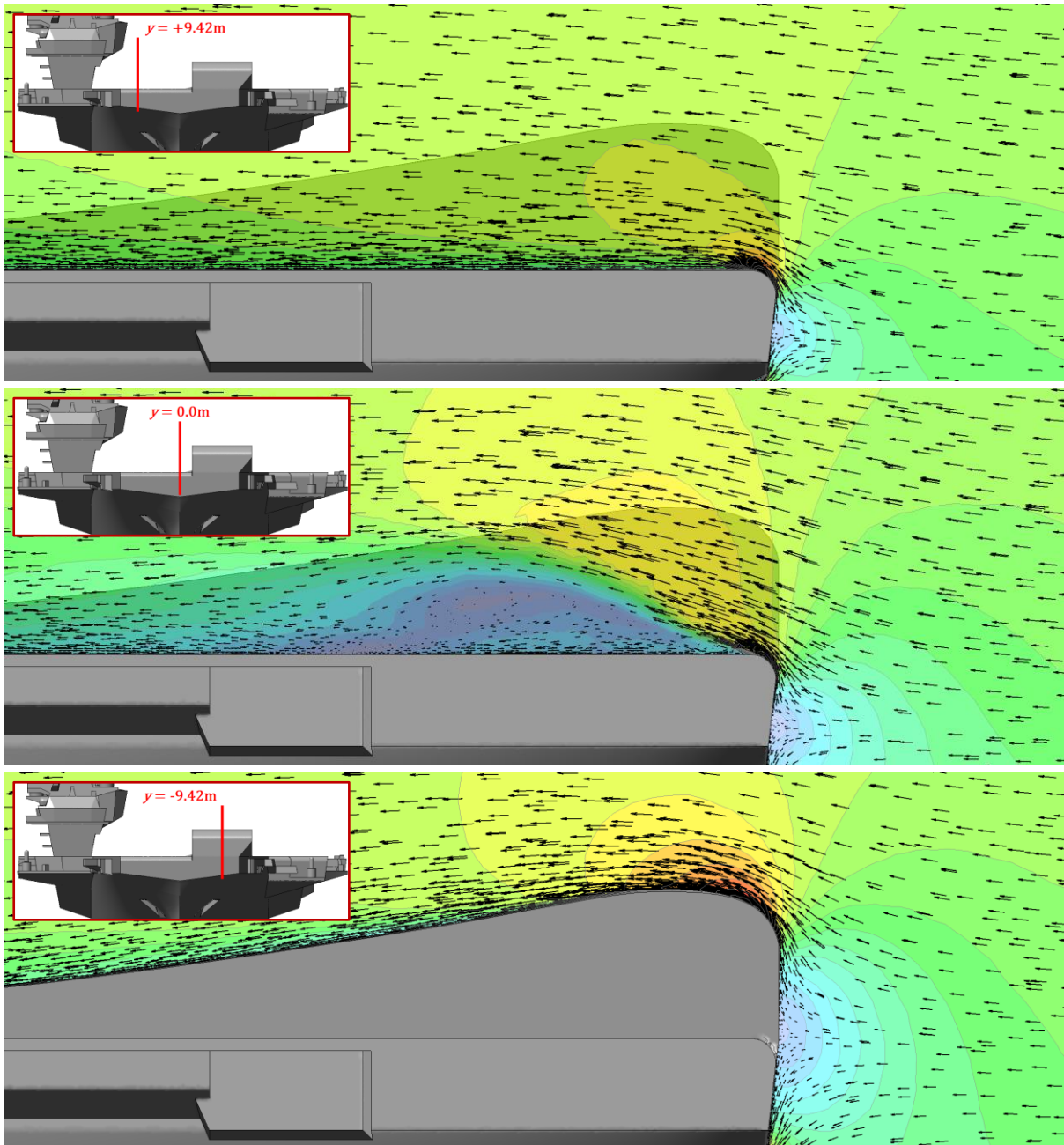

Figure 8: Normalised velocity, viewed from starboard.  $y=+9.42m$ ,  $y=0.0m$  (i.e. centreline), and  $y=-9.42m$ . Flow remains largely attached to the rounded leading edges of the deck and the ski-jump except at the sharp intersection of the two.



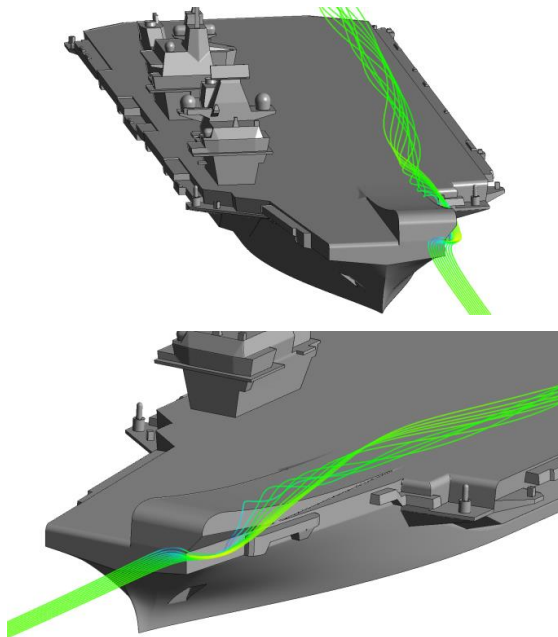

Figure 9: Views of mean streamlines over QEC rounded deck-edge

## EXPERIMENTAL STUDY OF QEC AIRWAKE

As described earlier, previous ship airwake research at UoL has been carried out for single-spot ships, where the CFD-generated airwakes were validated against available experimental data [12]. For the QEC it was necessary to design an experiment to provide validation data for this new class of problem. In particular, the requirement to accurately capture airwake features up to 400m (0.25 miles) aft of the ship pitch-centre places new requirements upon the CFD solution, with the implication that the current method requires new validation at this larger scale [22].

A validation experiment is currently being undertaken using the University's 90,000 litre re-circulating water channel, a schematic of which can be seen in Fig. 10. The channel has a  $1.176\text{m}^2$  working cross-section and a working length of 3.7m; flow speeds up to 6 m/s can be achieved and previous Laser Doppler Anemometer measurements have shown the free-stream turbulence through the working section to be approximately 3%, varying with flow speed [23]. When used in a free-surface configuration, the contraction guide vanes at the inlet ensure a largely uniform velocity across the working section, with small boundary layers forming in the immediate vicinity of walls (approximately

16mm thick at the centre of the working section). A thin water jet is added to the surface flow as it emerges from the contraction, preventing a velocity deficit at the free-surface. This jet is shown in Fig. 10, with the 1 mm high nozzle spanning the width of the channel [23].

A 1:202 scale (1.4m length) physical model of the QEC was produced, to be submerged and attached to the floor of the channel working section. The model was manufactured from ABS using Fused Deposition Modelling (FDM), produced in six interlocking sections due to model size constraints of the FDM facility (kindly provided by BAE Systems Warton). ABS was chosen due to its high impact resistance and dimensional stability in water, however it was found to have insufficient stiffness for the ship's mast, and so cobalt chrome was instead employed via Direct Metal Laser Sintering (DLMS) for this part. The assembled QEC experimental model is shown in Fig. 11.

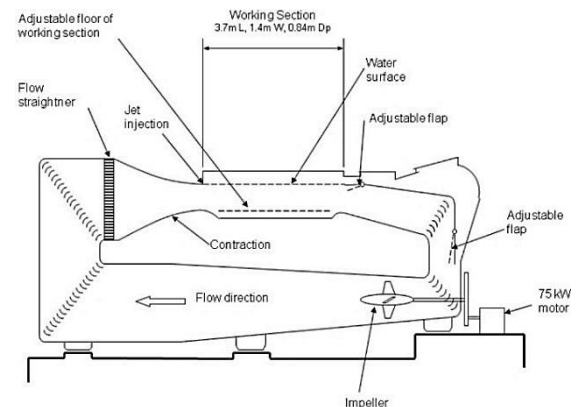

Figure 10: University of Liverpool re-circulating water channel

The model was centred to the floor of the water channel working section and fixed in position prior to flooding (i.e. the ship was "sunk" to the bottom of the channel), and can be rotated in yaw about its centre point to replicate  $0^\circ$ , and  $\pm 10^\circ$  wind over deck conditions. By using water instead of air as the test fluid, higher Reynolds numbers can be achieved due to the differences in density and viscosity between the two fluids. This increase in experimental Reynolds number is particularly useful when testing a very large structure such as an aircraft carrier, offsetting the comparatively small size of the scale test model.



Figure 11: Fully assembled QEC 1:202 scale (1.4m length) model

Measurements have been performed for water flow velocities up to 1.25m/s using an Acoustic Doppler Velocimeter (ADV), which is capable of measuring three components of the mean flow in addition to capturing unsteady turbulence statistics at 200Hz in one component depending upon probe orientation. To automatically and accurately position the ADV probe, a new three degree-of-freedom electronic, fully programmable traverse system has been fitted to the water channel working section. The ADV probe, when used with this traverse system, is able to measure the flow velocities at any point in the flow, and can be precisely located to sample data along a programmed matrix of test-points. The ADV unit can therefore be used to measure unsteady velocities at numerous points along the SRVL 7° glideslope and over the Vertical Take-Off & Landing (VTOL) landing spots, allowing a comparison to be made between CFD and experimentally derived velocities in the carrier airwake. Initial experimental results have been obtained, and are outlined in the next section.

### Preliminary ADV experimental results

A first experimental run was performed using ADV along the 7° SRVL approach path aft of the QEC physical model. A total of 103 individual test points were measured by the probe, with a spatial increment of 2.5cm in  $x$  along the ship centreline. The probe was programmed to sample at 200Hz, with at least 10,000 samples recorded to ensure convergence of turbulent statistics. The accuracy in the measurement of the mean flow velocity components is quoted by the ADV manufacturer to be  $\pm 0.5\%$ ; experience with the

probe suggests there is an additional uncertainty due to the size of the measurement volume so an estimate of the experimental uncertainty is  $\pm 1\%$  [23].

An initial comparison has been made between CFD and the ADV experiment results along the SRVL 7° centre-line parallel approach (i.e. the fixed-wing aircraft makes its approach parallel to the centre-line of the ship). This comparison can be seen in Fig. 12. It should be noted that due to the presence of the ABL profile (from Equation 1) in the CFD data, which causes variation in  $u$ -component velocity with height above sea level, unlike the uniform inlet velocity profile in the experiment, it was necessary to normalise each CFD data-point by ABL stream-wise velocity at each height above sea level. This normalisation allowed an initial comparison to be made between full-scale CFD and water-tunnel experimental data. It is intended that future work will include full CFD modelling of the water channel with a uniform inlet velocity profile to enable a direct comparison with the experimental data.

As can be seen from Fig. 12, the mean  $u$ -component velocity (WOD) offers reasonably good agreement between ADV and CFD along the SRVL glideslope immediately aft of the ship, with the peak velocity and its position accurately captured at approximately half a ship's length from the carrier pitch-centre. At two ship lengths from ship pitch centre, a slight ADV velocity peak can be seen, which is thought to be from the free-surface effects present in the water channel at this height. Very near to the ship, it can be seen that ADV and CFD data diverge; this could be due to differences in surface roughness between CFD and the experimental model, and possible interference between the model surface and ADV sampling volume. Further investigation is necessary to determine the cause of this behaviour. The  $w$ -component velocity (upwash) in Fig. 12 again shows good agreement in terms of position of the peak downwash, however the magnitudes of ADV data differs consistently across the SRVL glideslope; this may be caused by the ADV probe being orientated slightly off-vertical, resulting in a slight interference from  $u$ -component velocities in the smaller  $w$ -component velocities. The  $v$ -component

velocities (cross-wind, negative to starboard) in Fig. 12 are very small but nevertheless can be seen to show good agreement along the SRVL glideslope between ADV and CFD. In particular, turbulent effects caused by the aft island can be seen to be captured in both experimental and computational results for the  $v$ -component velocity.

While encouraging initial agreement has been demonstrated for mean velocities between experimental ADV and computational CFD results, further examination is ongoing to validate the unsteadiness along the SRVL glideslope to provide a robust validation of the CFD. Additionally, it is intended that further areas of the ship should be sampled using the ADV experimental set-up, in particular along the VTOL approach and hover points.

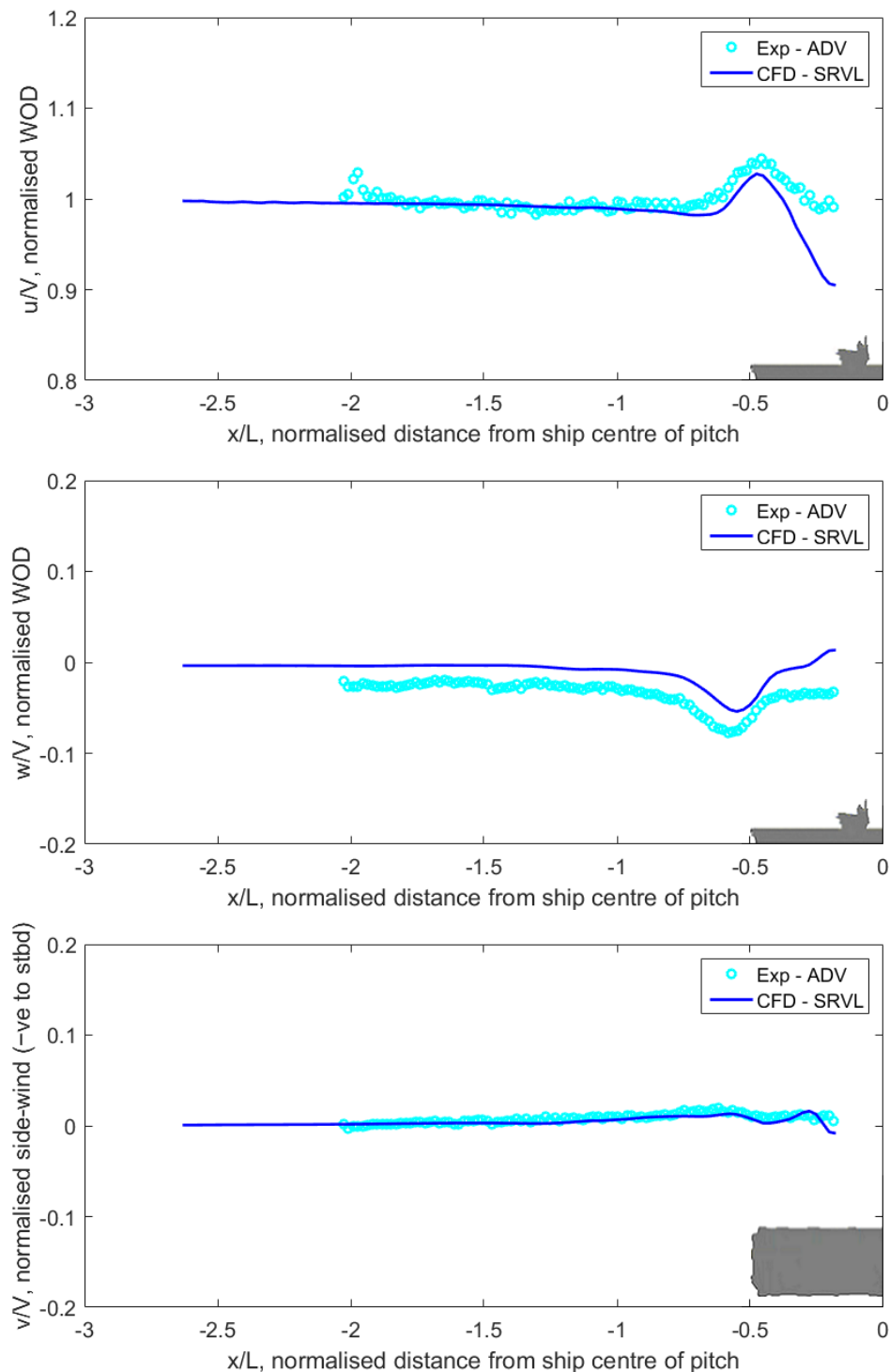

Figure 12: Mean velocity comparison along SRVL glideslope between CFD & ADV results

## CONCLUDING COMMENTS

The challenges faced in developing airwake models for an aircraft carrier simulation environment have been presented in this paper, together with details of an experiment being assembled to validate the CFD predictions. The paper has also outlined the progress made to date, in preparation for piloted simulation trials of fixed-wing aircraft launch and recovery operations to the QEC aircraft carriers. Initial CFD results have shown promise, indicating good agreement with ADV experimental data obtained to date. However, it has also been shown that the airwake simulation process for the large flight domain required for fixed-wing operations requires a modified approach from the previous simulations used for rotary-wing flight operations, where a more confined flight domain is used. Future work will refine the CFD method for operation of both fixed-wing and rotary-wing aircraft to the QEC carriers, with experimental methods developed and used to validate and optimise the solution. The validated CFD airwakes will then be implemented in the University of Liverpool and BAE Systems Warton flight simulators for simulated launch and recovery of both the rotary and fixed wing aircraft.

## ACKNOWLEDGEMENTS

The authors are grateful to Dr David Roper at ANSYS UK Ltd. for his continued support in the ongoing research at the University of Liverpool. The lead author would also like to acknowledge the Joseph Whitworth Trust and Whitworth Society for their continued support during his postgraduate studies. The first author is jointly funded by EPSRC and BAE Systems under an Industrial CASE Award (voucher 12220109).

## AUTHOR BIOGRAPHIES

**Michael Francis Kelly** is currently a PhD Candidate at the University of Liverpool. Prior to completing a BEng (Hons) Mechanical Engineering at the University of Liverpool in 2013, Michael began his career as a marine diesel engineer, before serving internships at Lloyd's Register, the classification society. *LinkedIn profile:* [uk.linkedin.com/in/mfkelly1](http://uk.linkedin.com/in/mfkelly1)

**Mark White** is a Senior Lecturer at the University of Liverpool. He has over 25 years of research experience including the last 15 years in the area of real-time piloted simulation. He received his bachelors and doctoral degrees from the University of Liverpool.

**Ieuan Owen** is emeritus professor of Mechanical Engineering and currently visiting professor at the University of Liverpool. He has some 40 years of experience in industrial fluid mechanics and has been working on ship superstructure aerodynamics and their effect on aircraft operations for the past fifteen years. He received his bachelor and doctoral degrees from the University of Wales, Cardiff.

**Steve Hodge** is Senior Flight Simulation Engineer with BAE Systems at Warton Aerodrome. He joined BAE in 1998 after gaining his Bachelor degree in Electronic Engineering from the University of Central Lancashire, and he obtained his PhD from the University of Liverpool in 2011.

## REFERENCES

1. P M Bevilaqua, "Inventing the F-35 Joint Strike Fighter", 47<sup>th</sup> AIAA Aerospace Sciences Meeting Including the New Horizons Forum and Aerospace Exposition, Orlando, Florida. AIAA 2009-1650 (January 2009)
2. A Lison, "Integrating the Joint Combat Aircraft into the Queen Elizabeth Class Aircraft Carriers – Design Challenge or Opportunity?", Warship 2009 – 'Airpower at Sea', London, UK (June 2009).
3. G D Carico, R Fang, R S Finch, W P Geyer Jr, H W Krijins, K Long, "Helicopter/Ship Qualification Testing". NATO SCI-055 Task Group, RTO-AG-300 Vol 22 (February 2003).
4. J S Forrest, I Owen, G D Padfield, and S J Hodge, "Ship-Helicopter Operating Limits Prediction Using Piloted Flight Simulation and Time-Accurate Airwakes". Jnl of Aircraft, Vol 49, pp. 1020-1031 (July 2012).
5. S J Hodge, "Dynamic Interface Modelling and Simulation Fidelity Criteria". Ph.D thesis, University of Liverpool (2011).
6. Navy News, "Wildcat impresses during its first trials aboard a warship". Retrieved

- October 6, 2012, from <https://navynews.co.uk/archive/news/item/3691> (February 2012).
7. M F Roscoe, and C H Wilkinson, "DIMSS – JSHIP's Modelling and Simulation Process for Ship/Helicopter Testing & Training". AIAA Modelling and Simulation Technologies Conference and Exhibit, Guidance, Navigation, and Control and Co-located Conferences (August 2002).
  8. S Hodge, J S Forrest, G D Padfield, and I Owen, "Simulating the environment at the aircraft-ship dynamic interface: research, development, & application". *The Aeronautical Journal*, Vol. 116, No. 1185, pp. 1155-1184 (November 2012).
  9. J S Forrest, C H Kaaria, I Owen, "Evaluating ship superstructure aerodynamics for maritime helicopter operations through CFD and flight simulation". *The Aeronautical Journal*, available on CJO 2016 doi:10.1017/aer.2016.76 (July 2016).
  10. M D White, P Perfect, G D Padfield, A W Gubbels, and A C Berryman, "Acceptance testing and commissioning of a flight simulator for rotorcraft simulation fidelity research". *Proceedings of the IMechE, Part G: Journal of Aerospace Engineering*, Volume 227 Issue 4, pp. 663–686 (April 2013).
  11. P R Spalart, S Deck, M L Shur, K D Squires, M Kh Strelets, A Travin, "A New Version of Detached-Eddy Simulation, Resistant to Ambiguous Grid Densities". *Theoretical and Computational Fluid Dynamics*, Vol. 20, Issue 3, pp. 181 (July 2006).
  12. J S Forrest, I Owen, "An investigation of ship airwakes using Detached-Eddy Simulation". *Computers & Fluids*, Volume 39, Issue 4, pp. 656-673 (April 2010).
  13. T Rudowsky, S Cook, M Hynes, R Heffley, M Luter, T Lawrence, et al., "Review of the Carrier Approach Criteria for Carrier-Based Aircraft – Phase I; Final". Patuxent River, MD: Naval Air Warfare Center Aircraft Division, Rept. NAWCADPAX/TR-2002/71 (October 2002).
  14. S Polsky, S Naylor, "CVN Airwake Modeling and Integration: Initial Steps in the Creation and Implementation of a Virtual Burble for F-18 Carrier Landing Simulations". AIAA Modeling and Simulation Technologies Conference and Exhibit, San Francisco, California (August 2005).
  15. M F Kelly, M D White, I Owen, S J Hodge, "Using airwake simulation to inform flight trials for the Queen Elizabeth Class Carrier", *IMarEST 13<sup>th</sup> International Naval Engineering Conference and Exhibition (INEC 2016)*, Bristol UK (April 2016).
  16. B Thornber, M Starr, D Drikakis, "Implicit large eddy simulation of ship airwakes". *The Aeronautical Journal*, Vol. 114, No. 1162 (December 2010).
  17. J D Anderson, "Computational fluid dynamics: the basics with applications". McGraw-Hill, Inc. (1995).
  18. R M Czerwiec, S A Polsky, "LHA Airwake Wind Tunnel and CFD Comparison with and without Bow Flap". *22nd Applied Aerodynamics Conference and Exhibit, Guidance, Navigation, and Control and Co-located Conferences* (August 2004).
  19. K R Cooper, "The Effect of Front-Edge Rounding and Rear-Edge Shaping on the Aerodynamic Drag of Bluff Vehicles in Ground Proximity". *SAE Technical Paper 850288* (February 1985).
  20. W H Hucho, L J Janssen and H J Emmelmann, "The Optimization of Body Details – A Method for Reducing the Aerodynamic Drag of Road Vehicles". *SAE Technical Paper 760185* (February 1976).
  21. J E Bardina, P G Huang, T J Coakley, "Turbulence Modeling Validation, Testing, and Development". *NASA Technical Memorandum 110446* (April 1997).
  22. "Guide for the Verification and Validation of Computational Fluid Dynamics Simulations (AIAA G-077-1998(2002))", AIAA Standards (2002).
  23. Tedds, S. C., "Scale Model Testing of Tidal Stream Turbines: Wake Characterisation in Realistic Flow Conditions". *University of Liverpool*. (February 2014).