

# Multi-Objective Demand Side Scheduling Considering the Operational Safety of Appliances

Y.F. Du<sup>a</sup>, L. Jiang<sup>a</sup>, Y.Z. Li<sup>a</sup>, J. Counsell<sup>a</sup>, J.S. Smith<sup>a</sup>

<sup>a</sup>*Department of Electrical Engineering and Electronics, University of Liverpool, Liverpool, L69 3GJ, U.K.*

---

## Abstract

The safe operation of appliances is of great concern to users. The safety risk increases when the appliances are in operation during periods when users are not at home or when they are asleep. In this paper, multi-objective demand side scheduling is investigated with consideration to the appliances' operational safety together with the electricity cost and the operational delay. The formulation of appliances' operational safety is proposed based on users' at-home status and awake status. Then the relationships between the operational safety and the other two objectives are investigated through the approach of finding the Pareto-optimal front. Moreover, this approach is compared with the Weigh and Constraint approaches. As the Pareto-optimal front consists of a set of optimal solutions, this paper proposes a method to make the final scheduling decision based on the relationships among the multiple objectives. Simulation results demonstrate that the operational safety is improved with the sacrifice of the electricity cost and the operational delay, and that the approach of finding the Pareto-optimal front is effective in presenting comprehensive optimal solutions of the multi-objective demand side scheduling.

*Keywords:* Operational safety of appliances, multiple objectives, Pareto-optimal front, demand side scheduling, energy usage optimization.

---

*Email address:* [ljiang@liverpool.ac.uk](mailto:ljiang@liverpool.ac.uk) (L. Jiang)

*Preprint submitted to*

*August 1, 2016*

## 1. Introduction

Demand side scheduling aims to schedule the energy consumption of appliances in response to varying electricity prices over time, or to incentive payments, or when system reliability is jeopardized [1, 2, 3]. Multiple objectives have been considered in the demand side scheduling, such as the minimization of the electricity cost [4, 5, 6, 7, 8], the reduction in the delay of the appliances' operations [6, 7], the improvement of the system reliability [9], the promotion of the renewable energy [10, 11], and the improvement of the users' convenience level [8]. However, to the best knowledge of the authors, improving the operational safety of appliances has not been considered in demand side scheduling, and it should be paid more attention. 1083 fires caused by washing machines and tumble driers, and 475 fires caused by dishwashers had happened in the United Kingdom in 2011/2012 [12]. 8500 fires caused by home appliances had resulted in a 265 million dollar loss in the United States in 2010 [13]. It is evident that the consequences in the cases of the appliances' faults will deteriorate if the appliances are in operation during periods when users are not at home or are asleep. As the safety risk is of great concern to users, the operational safety is worth considering in demand side scheduling to further optimize the energy usage. The relationships between the operational safety and other objectives need clarified with the operational safety taken into account as a new objective.

Multi-objective demand side scheduling (MODSS) takes into account several objectives simultaneously and is usually solved by converting multiple objectives to a single objective [4, 5, 6, 7]. [6, 7] weigh the importance of multiple objectives and sum the objectives with their corresponding importance factors as the final objective function. One objective is optimized with constraints that confine the deviations of other objectives from their corresponding optimal values within certain ranges as described in [4, 5]. However, the approach that weighs the importance of each objective in the final objective function makes the physical meaning of the final objective unclear, and its solution largely depends on the predefined weights of multiple objectives [6, 7]. The approach that sets constraints to objectives does not optimize the objectives in the constraints and it only requires them within certain ranges, and the solution of this approach depends on the predefined ranges in the constraints [4, 5]. An alternative approach to those that tackle multiple objectives through the conversion and then the optimization of the final objective function, is to simultaneously optimize multiple objectives directly

through finding the Pareto-optimal front. This approach does not depend on the predefined weights or ranges, and it simultaneously optimizes multiple objectives with clear physical meaning [14]. The approach of finding the Pareto-optimal front is presented in [14]. However, to the best knowledge of the authors, no previous work compares this approach with the other approaches in dealing with MODSS.

In this paper, the improvement of appliances' operational safety is proposed as a new objective of the MODSS, to further optimize the scheduling of energy consumption. The approach of finding the Pareto-optimal front is adopted to deal with the MODSS and to investigate the relationships between the operational safety and other objectives. This approach is compared with the approach that weighs the importance of multiple objectives and the approach that sets constraints to the deviations of objectives from their optimal values. For convenience, these three approaches are referred to as the Pareto approach, the Weigh approach and the Constraint approach, respectively. The operational safety is taken into account based on whether users are at home and awake to supervise the appliances' operations. Apart from the operational safety, the electricity cost and the operational delay are considered in the MODSS. Since the reduction of the electricity cost is the motivation for users to participate in demand side scheduling, it should be considered in the MODSS [1, 4, 5]. As the operational delay relates to the wish that the operations of the appliances are completed as soon as possible [7, 15, 16], the operational delay is more often given a higher weighting compared with other objectives [6, 7, 15, 16] and is taken into account in this paper. Three situations considering the operational safety together with one or both of the electricity cost and the operational delay are considered in the comparison between the Pareto approach and the other two approaches. Furthermore, a method considering the relationships among the three objectives is proposed to make the final scheduling decision of energy consumption among solutions of the Pareto-optimal front.

The rest of the paper is organized as follows. The system model is presented in Section 2. Section 3 introduces the multi-objective demand side scheduling and the three approaches dealing with multiple objectives are presented in Section 4. Section 5 introduces the method of decision making based on the Pareto approach and simulations are presented in Section 6. Finally, conclusions are presented in Section 7.

## 2. System model

The structure of the energy management system is shown in Fig. 1. Based on the day-ahead real-time electricity price, the users' demands for the appliances' operations and the users' at-home and awake status, the energy management controller (EMC) will automatically control the energy consumption of shiftable (time adjustable) appliances.

The EMC is the main part of the energy management system. The electricity price is transmitted to the EMC a day ahead with the real-time price for next day from the utility company [8, 17, 18]. The users' demands for the appliances' operations and their at-home and awake status are defined and input to the EMC by users as users have different demands for appliances' operations and their at-home status and awake status are different as well. Based on the day-ahead real-time electricity price, users' demands and status, the EMC works out the energy consumption schedules for home appliances based on the proposed method that will be introduced in the following sections. Then the appliances will be controlled automatically by the EMC according to the energy consumption schedules through the home area network [6, 7]. The home appliances are categorized into shiftable appliances and manually operated appliances. The energy consumption of shiftable appliances, such as water heaters and washing machines, is flexible and they can be scheduled in advance [18, 19, 20], and are assumed to be non-interruptible [5]. The manually operated appliances whose energy consumption is fixed and manually controlled based on users' real-time demands, such as TV and

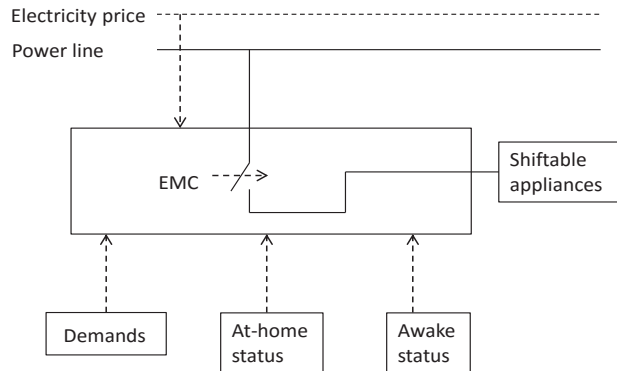

Fig. 1: Energy management system

lights, are not included in the energy management system [21].

The users' demands for appliances' operations include the length of operation time (LOT) and the operation time interval (OTI), which are represented by  $\gamma_a$  and  $[\alpha_a, \beta_a]$  for appliance  $a$ , respectively [6], where  $\alpha_a$  indicates the earliest start time of the operation and  $\beta_a$  indicates the deadline for finishing the operation. Considering the general operation time of appliances, 1 hour is divided into 5 time slots [6] and the LOT is mapped to time slots with one time slot representing 12 minutes. For example, the LOT is 2, i.e.,  $\gamma = 2$ , for an appliance whose operation length is 24 minutes. The LOT is approximated to be the greater and nearest integer when the operation length is not an integer multiple of 12 minutes [6]. One day is mapped to 120 time slots and the OTI is also mapped to the corresponding time slot. For instance, the OTI is from 1 to 60, i.e.,  $\alpha = 1, \beta = 60$ , for an appliance whose operation is predefined between 12 midnight and 12 noon.

### 3. Multi-objective demand side scheduling

The multiple objectives including the minimizations of the appliances' operational unsafety (i.e., the maximization of the appliances' operational safety), the electricity cost and the appliances' operational delay are considered in MODSS, and their formulations are presented as follows.

#### 3.1. Multiple objectives

- Objective 1: Minimization of appliances' operational unsafety

The operational unsafety of appliances is taken into account based on whether users are at home and awake to supervise the appliances' operations. The situation that the energy consumption of appliances is scheduled in periods when users are not at home or are asleep is to be reduced and this

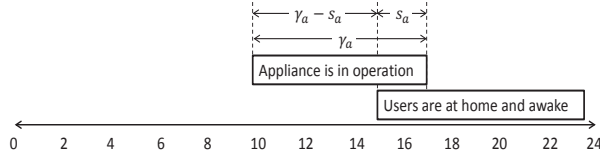

Fig. 2: The illustration of the concept of unsafety time rate

situation is quantified by introducing the unsafety time rate

$$\begin{aligned}
 UTR_a(x_a) &= \frac{\gamma_a - s_a(x_a)}{\gamma_a} \\
 s_a(x_a) &= \sum_{t=1}^T S_a(x_a, t) \cdot M(t) \cdot N(t) \\
 S_a(x_a, t) &= \begin{cases} 1, & t \in [x_a, x_a + \gamma_a - 1] \\ 0, & t \in H \setminus [x_a, x_a + \gamma_a - 1] \end{cases} \\
 M(t) &= \begin{cases} 1, & \text{users are at home} \\ 0, & \text{users are away} \end{cases} \\
 N(t) &= \begin{cases} 1, & \text{users are awake} \\ 0, & \text{users are asleep} \end{cases} \\
 H &= \{1, 2, \dots, T\}, \quad x_a \in [\alpha_a, \beta_a - \gamma_a + 1]
 \end{aligned} \tag{1}$$

where  $UTR_a$  denotes the unsafety time rate of appliance  $a$  and  $x_a$  is the start time slot of the appliance's operation.  $s_a$  denotes the number of time slots that users are at home and awake when appliance  $a$  is in operation and it is determined by the appliance's operation status  $S_a(x_a, t)$  with the knowledge of users' at-home status  $M(t)$  and awake status  $N(t)$  in a day. The expression  $t \in H \setminus [x_a, x_a + \gamma_a - 1]$  indicates that  $t$  belongs to  $H = \{1, 2, \dots, T\}$  excluding the range  $[x_a, x_a + \gamma_a - 1]$  and  $T = 120$  is the scheduling horizon that indicates the number of time slots ahead which the energy consumption schedule is made for shiftable appliances.  $x_a \in [\alpha_a, \beta_a - \gamma_a + 1]$  since the operation should start ahead the deadline by at least the length of the operation time. Fig. 2 shows the illustration of the concept of unsafety time rate.

For a home with  $n$  shiftable appliances, the minimization of the appli-

ances' operational unsafety is formulated as

$$\begin{aligned}
& \min_X f_1(X) \\
& f_1(X) = \sum_{a=1}^n \rho_a^{UTR_a(x_a)} \\
& UTR_a(x_a) = \frac{\gamma_a - s_a(x_a)}{\gamma_a} \\
& s_a(x_a) = \sum_{t=1}^T S_a(x_a, t) \cdot M(t) \cdot N(t) \\
& S_a(x_a, t) = \begin{cases} 1, & t \in [x_a, x_a + \gamma_a - 1] \\ 0, & t \in H \setminus [x_a, x_a + \gamma_a - 1] \end{cases} \\
& M(t) = \begin{cases} 1, & \text{users are at home} \\ 0, & \text{users are away} \end{cases} \\
& N(t) = \begin{cases} 1, & \text{users are awake} \\ 0, & \text{users are asleep} \end{cases} \\
& H = \{1, 2, \dots, T\} \\
& X = \{x_1, x_2, \dots, x_a, \dots, x_n\} \\
& \text{subject to} \\
& x_a \in [\alpha_a, \beta_a - \gamma_a + 1], \quad a = \{1, 2, \dots, n\}
\end{aligned} \tag{2}$$

where  $X = \{x_1, x_2, \dots, x_a, \dots, x_n\}$  denotes the set of appliances' start time slots, and  $\rho_a > 1$  denotes the unsafety parameter of appliance  $a$ , the higher the value of  $\rho_a$ , the higher will be the cost of the operational unsafety. When the start time slots of appliances are determined, the unsafety time rates (UTRs) of appliances are obtained based on (1) and the operational unsafety is obtained with  $\rho_a^{UTR_a}$ . With the higher value of the unsafety parameter  $\rho_a$ , the operational unsafety will be higher. The UTR is the ratio between the time slots of unsafe operation and the operation length, and the time slots of unsafe operation are the ones when the appliance is in operation but users are not at home or users are asleep. Note that different appliances may have the same UTR and  $\rho_a$  is introduced to differentiate the operational unsafety of appliances, and that the UTR and  $\rho_a$  jointly determine the appliance's operational unsafety with  $\rho_a^{UTR_a}$ .

It is noted that the users' at-home status  $M(t)$  and awake status  $N(t)$  are individually defined by users as different users have different at-home status and awake status. Based on the users' predefined at-home status and awake status, the appliances' operational unsafety is obtained by (2). For the same energy consumption schedule, the operational unsafety is different under different users' statuses. For example, when the washing machine is

scheduled to operate through 49 time slot to 53 time slot, for one user who is at home all day long except the period from 51 time slot to 60 time slot, and awake from 41 time slot to 115 time slot and asleep for other time slots, the UTR of the washing machine is 3/5 while the UTR is 0 for another user who is with the same awake status and at-home all day long. The corresponding operational unsafety of the washing machine are 1.52 and 1 for the two users with different at-home statuses, respectively, when the unsafety parameter of washing machine is assumed to be 2.

- Objective 2: Minimization of electricity cost

Let  $p_a$  denote the power of appliance  $a$ . Since 1 hour is divided into 5 time slots and it is assumed that the energy consumption is the same in all the time slots during the operation periods of an appliance [6], the energy consumption of appliance  $a$  in a time slot is  $\frac{p_a}{5}$  when it is in operation. The energy consumption schedule of appliance  $a$  is

$$\begin{aligned}
 E_a &= \left\{ \begin{array}{ll} e_a^t | e_a^t = \frac{p_a}{5}, & t \in [x_a, x_a + \gamma_a - 1], \\ e_a^t = 0, & t \in H \setminus [x_a, x_a + \gamma_a - 1], \end{array} \right. & (3) \\
 H &= \{1, 2, \dots, T\}, \quad x_a \in [\alpha_a, \beta_a - \gamma_a + 1]
 \end{aligned}$$

where  $e_a^t$  is the energy consumption of appliance  $a$  during time slot  $t$ . Based on the energy consumption of appliances and the day-ahead real-time electricity price, the minimization of electricity cost is formulated as

$$\begin{aligned}
 &\min_X f_2(X) \\
 f_2(X) &= \sum_{t=1}^T \text{prc}_t \cdot l_t(X) \\
 l_t(X) &= \sum_{a=1}^n e_a^t & (4) \\
 X &= \{x_1, x_2, \dots, x_a, \dots, x_n\} \\
 &\text{subject to} \\
 &x_a \in [\alpha_a, \beta_a - \gamma_a + 1], \quad a = \{1, 2, \dots, n\}
 \end{aligned}$$

where  $\text{prc}_t$  is the real-time electricity price at time slot  $t$ , and  $l_t$  is the total energy consumption of all the shiftable appliances during time slot  $t$ , and it can be obtained when the set of start time slots of all appliances  $X$  is determined and the energy consumption of each appliance is scheduled by (3).



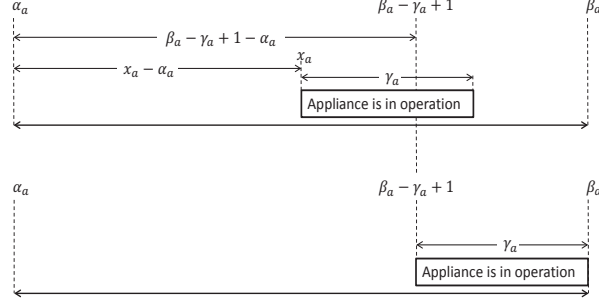

Fig. 3: The illustration of the concept of delay time rate

- Objective 3: Minimization of appliances' operational delay

As shown in Fig. 3, the appliance's operational delay is the delay time from  $\alpha_a$ , the earliest start time of the operation, and the longest delay occurs when the appliance just meets the deadline to finish its operation, i.e., the appliance starts at the time slot  $\beta_a - \gamma_a + 1$  [6]. The delay time rate is introduced to illustrate the appliance's operational delay

$$DTR_a(x_a) = \frac{x_a - \alpha_a}{\beta_a - \gamma_a + 1 - \alpha_a} \quad (5)$$

where  $DTR_a$  is the delay time rate of appliance  $a$ . For a home with  $n$  shiftable appliances, the minimization of operational delay is formulated as

$$\begin{aligned} & \min_X f_3(X) \\ & f_3(X) = \sum_{a=1}^n \sigma_a DTR_a(x_a) \\ & DTR_a(x_a) = \frac{x_a - \alpha_a}{\beta_a - \gamma_a + 1 - \alpha_a} \\ & X = \{x_1, x_2, \dots, x_a, \dots, x_n\} \\ & \text{subject to} \\ & x_a \in [\alpha_a, \beta_a - \gamma_a + 1], \quad a = \{1, 2, \dots, n\} \end{aligned} \quad (6)$$

where  $\sigma_a > 1$  denotes the delay parameter of appliance  $a$ , the higher the value of  $\sigma_a$ , the higher will be the cost of the operational delay [6].

### 3.2. Problem formulation

Considering minimizations of the appliances' operational unsafety, the electricity cost and the appliances' operational delay, the MODSS is formu-

lated as

$$\begin{aligned}
& \min_X F(X) \\
& F(X) = (f_1(X), f_2(X), f_3(X)) \\
& f_1(X) = \sum_{a=1}^n \rho_a^{UTR_a(x_a)}, \quad UTR_a(x_a) = \frac{\gamma_a - s_a(x_a)}{\gamma_a} \\
& f_2(X) = \sum_{t=1}^T prc_t \cdot l_t(X), \quad l_t(X) = \sum_{a=1}^n e_a^t \\
& f_3(X) = \sum_{a=1}^n \sigma_a^{DTR_a(x_a)}, \quad DTR_a(x_a) = \frac{x_a - \alpha_a}{\beta_a - \gamma_a + 1 - \alpha_a} \\
& X = \{x_1, x_2, \dots, x_a, \dots, x_n\} \\
& \text{subject to} \\
& x_a \in [\alpha_a, \beta_a - \gamma_a + 1], \quad a = \{1, 2, \dots, n\}
\end{aligned} \tag{7}$$

where  $F(X)$  is the set of multiple objective functions.

#### 4. Three approaches for dealing with multiple objectives

To solve the problem of demand side scheduling with consideration of the multiple objectives presented in the previous section, three approaches including the Pareto approach, the Weigh approach and the Constraint approach are presented in this section.

##### 4.1. Pareto approach

The Pareto approach aims to find a set of optimal solutions to the multi-objective optimization problem and these solutions are nondominated by other solutions in the feasible domain, which is defined as follows. Let  $\Omega$  denote the set of feasible solutions of (7)

$$\begin{aligned}
\Omega = \{X | X = \{x_1, x_2, \dots, x_a, \dots, x_n\}, \\
x_a \in [\alpha_a, \beta_a - \gamma_a + 1], \quad a = \{1, 2, \dots, n\}\}.
\end{aligned} \tag{8}$$

For the set of appliances' start time slots  $X_i, X_j \in \Omega$ , if

$$\begin{cases} f_1(X_i) < f_1(X_j) \\ f_2(X_i) < f_2(X_j) \\ f_3(X_i) < f_3(X_j) \end{cases} \tag{9}$$

it can be defined that  $F(X_i) < F(X_j)$  and  $X_i$  dominates  $X_j$  [14]. That  $X_i$  dominates  $X_j$  shows all the objectives of solution  $X_i$  are better than that of

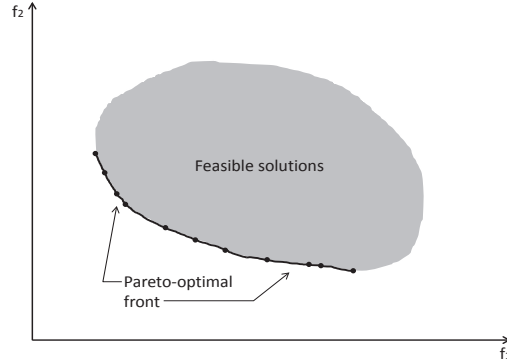

Fig. 4: The Pareto-optimal front

$X_j$ . If some objectives of  $X_i$  are better and some are worse than the corresponding objectives of  $X_j$ , it cannot be concluded that  $X_i$  dominates  $X_j$ . Let  $\mathbf{X} = \{X_1, X_2, \dots, X_k\}$  denote the set of nondominated solutions. For each  $X_j \in \mathbf{X}$ , it is not possible to find a  $X_i \in \Omega$  that satisfies  $F(X_i) < F(X_j)$ , i.e., there is no solution among the feasible solutions that satisfies all the objectives are better than the solutions in  $\mathbf{X}$ . The objective values of the solutions of the nondominated set constitute a front known as the Pareto-optimal front, i.e., the nondominated solutions are the ones corresponding to the Pareto-optimal front. Fig. 4 shows the concept of the Pareto-optimal front based on an optimization problem with consideration of the minimizations of two objectives [22]. It can be seen from Fig. 4 that no solutions among feasible solutions satisfy both  $f_1$  and  $f_2$  are smaller than the solutions of the Pareto-optimal front. To obtain the solutions of the Pareto-optimal front, the nondominated sorting genetic algorithm-II (NSGA-II) is usually adopted, and more details of this algorithm can be found in [22].

#### 4.2. Weigh approach

The Weigh approach attaches importance factors to the three objectives in (7). To make the three objectives commensurable, the problem of demand

side scheduling considering multiple objectives is formulated as

$$\begin{aligned}
& \min_X w_1 \frac{f_1(X)}{\underline{f}_1} + w_2 \frac{f_2(X)}{\underline{f}_2} + w_3 \frac{f_3(X)}{\underline{f}_3} \\
& w_1 + w_2 + w_3 = 1 \\
& f_1(X) = \sum_{a=1}^n \rho_a^{UTR_a(x_a)}, \quad UTR_a(x_a) = \frac{\gamma_a - s_a(x_a)}{\gamma_a} \\
& f_2(X) = \sum_{t=1}^T prc_t \cdot l_t(X), \quad l_t(X) = \sum_{a=1}^n e_a^t \\
& f_3(X) = \sum_{a=1}^n \sigma_a^{DTR_a(x_a)}, \quad DTR_a(x_a) = \frac{x_a - \alpha_a}{\beta_a - \gamma_a + 1 - \alpha_a} \quad (10) \\
& \underline{f}_1 = \min_{X \in \Omega} f_1(X) \\
& \underline{f}_2 = \min_{X \in \Omega} f_2(X) \\
& \underline{f}_3 = \min_{X \in \Omega} f_3(X) \\
& X = \{x_1, x_2, \dots, x_a, \dots, x_n\} \\
& \text{subject to} \\
& x_a \in [\alpha_a, \beta_a - \gamma_a + 1], \quad a = \{1, 2, \dots, n\}
\end{aligned}$$

where  $0 \leq w_1, w_2, w_3 \leq 1$  are the importance factors of the operational unsafety, the electricity cost and the operational delay, respectively, and  $\underline{f}_1$ ,  $\underline{f}_2$  and  $\underline{f}_3$  are the minimum values of  $f_1(X)$ ,  $f_2(X)$  and  $f_3(X)$ . Using the Weigh approach, the multi-objective optimization problem is converted to a problem with a single objective, which can be solved by genetic algorithm (GA), and only one optimal solution will be obtained [6, 7].

#### 4.3. Constraint approach

The Constraint approach optimizes one objective in (7) subject to the constraint that the deviations of the other two objectives from their corresponding optimal values are within certain ranges. Taking as an example that  $f_1(X)$  is minimized with the constraints of  $f_2(X)$  and  $f_3(X)$ , the problem of demand side scheduling considering multiple objectives through the

Constraint approach is formulated as

$$\begin{aligned}
& \min_X f_1(X) \\
& f_1(X) = \sum_{a=1}^n \rho_a^{UTR_a(x_a)}, \quad UTR_a(x_a) = \frac{\gamma_a - s_a(x_a)}{\gamma_a} \\
& X = \{x_1, x_2, \dots, x_a, \dots, x_n\} \\
& \text{subject to} \\
& \underline{f}_2(X) \leq (1 + \eta_2) \underline{f}_2 \\
& \underline{f}_3(X) \leq (1 + \eta_3) \underline{f}_3 \\
& f_2(X) = \sum_{t=1}^T prc_t \cdot l_t(X), \quad l_t(X) = \sum_{a=1}^n e_a^t \\
& f_3(X) = \sum_{a=1}^n \sigma_a^{DTR_a(x_a)}, \quad DTR_a(x_a) = \frac{x_a - \alpha_a}{\beta_a - \gamma_a + 1 - \alpha_a} \\
& \underline{f}_2 = \min_{X \in \Omega} f_2(X) \\
& \underline{f}_3 = \min_{X \in \Omega} f_3(X) \\
& x_a \in [\alpha_a, \beta_a - \gamma_a + 1], \quad a = \{1, 2, \dots, n\}
\end{aligned} \tag{11}$$

where  $\eta_2, \eta_3 \geq 0$  are the constraint factors of the electricity cost and the operational delay, respectively [5]. The problem (11) can also be solved through GA and only one optimal solution will be obtained [4, 5].

It can be seen from the formulations of approaches that the Weigh approach and the Constraint approach depend on the importance factors and the constraint factors, respectively. The physical meaning of the objective function of the Weigh approach is unclear and the objectives in the constraints are not optimized for the Constraint approach. By comparison, the Pareto approach does not depend on the predefined factors and it simultaneously optimizes multiple objectives with clear physical meaning. Therefore, the Pareto approach is adopted to solve the problem of MODSS.

## 5. Decision making of the Pareto approach

As the Pareto approach provides a set of optimal solutions, this paper proposes a method to make the final scheduling decision taking into account the importance factors  $w_1, w_2, w_3$  of the three objectives. The important factors can be defined by users, or users can just define the importance rank of the three objectives. It is quite common for users to only provide the importance rank when multiple objectives are taken into account [23]. Considering that the sum of the importance factors is 1 and that the more important

objective has a higher factor, the importance factors are determined by the EMC with  $w_m = (1/N) \sum_{j=\delta_m}^N (1/j)$ ,  $m = 1, 2, \dots, N$  [23, 24, 25, 26].  $N$  denotes the number of objectives and  $\delta_m$  denotes the importance rank of objective  $m$ . For example, if the importance rank of the three objectives is objective 1, objective 2, objective 3, i.e., the objective 1 is the most important, following objective 2 and objective 3, the importance factors are  $w_1 = 11/18$ ,  $w_2 = 5/18$  and  $w_3 = 1/9$ .

Let  $F^i = (f_1^i, f_2^i, f_3^i)$  denote the  $i$ th solution of the Pareto-optimal front, where  $f_1^i$ ,  $f_2^i$  and  $f_3^i$  represent the values of objective 1, objective 2 and objective 3, respectively,  $i \in I = \{1, 2, \dots, k\}$  and  $k$  is the number of solutions of the Pareto-optimal front. Firstly, the Pareto-optimal solutions are sorted based on the order that the value of the most important objective is increasing. If the values of the most important objective are equal, the solutions are sorted according to the order that the value of the sub-important objective is increasing, etc. For example, if  $w_1 \geq w_2 \geq w_3$ , the final rank of Pareto-optimal solutions satisfies

$$\begin{cases} f_1^j \leq f_1^{j+1} \\ f_2^j \leq f_2^{j+1} & \text{if } f_1^j = f_1^{j+1} \\ f_3^j \leq f_3^{j+1} & \text{if } f_1^j = f_1^{j+1} \text{ and } f_2^j = f_2^{j+1} \end{cases} \quad (12)$$

for any  $j \in \{1, 2, \dots, k-1\}$ . Then, the final decision  $F^* = (f_1^*, f_2^*, f_3^*)$  is made taking into account the rank of the Pareto-optimal solutions and the following rule. The solution with a smaller rank number, i.e., with a smaller value of the more important objective, is chosen to be the final optimal solution unless the sacrifice of this objective can bring sufficient improvement to the sub-important objective. For example, if two objectives are considered with  $w_1 = 0.8$  and  $w_2 = 0.2$ , i.e., objective 1 is four times more important than objective 2, the solution with a smaller value of objective 1 is preferred. However, if 1% of the sacrifice of objective 1 can bring greater than 4% of an improvement to objective 2, the sacrifice of objective 1 brings sufficient improvement to objective 2 and the solution with the bigger objective 1 and smaller objective 2 is chosen.

The procedure for the final decision making based on the obtained rank of the Pareto-optimal solutions is

**Step 1**  $F^* = F^1, i = 2$

**Step 2** if  $\{f_1^i > f_1^* \text{ and } (13)\}$

$$\begin{cases} \frac{(f_2^* - f_2^i)/(f_2^{\max} - f_2^{\min})}{(f_1^i - f_1^*)/(f_1^{\max} - f_1^{\min})} > \frac{w_1}{w_2} \\ f_3^* \geq f_3^i \end{cases} \quad (13)$$

then  $F^* = F^i$

**Step 3** if  $\{f_1^i = f_1^*$  and (14) $\}$

$$\frac{(f_3^* - f_3^i)/(f_3^{\max} - f_3^{\min})}{(f_2^i - f_2^*)/(f_2^{\max} - f_2^{\min})} > \frac{w_2}{w_3} \quad (14)$$

then  $F^* = F^i$

**Step 4**  $i = i + 1$  and go to **Step 2**

where  $f_1^{\min} = \min_{i \in I} f_1^i$ ,  $f_2^{\min} = \min_{i \in I} f_2^i$ ,  $f_3^{\min} = \min_{i \in I} f_3^i$ ,  $f_1^{\max} = \max_{i \in I} f_1^i$ ,  $f_2^{\max} = \max_{i \in I} f_2^i$  and  $f_3^{\max} = \max_{i \in I} f_3^i$ . Step 2 shows that when three objectives are considered, in addition to the requirement that any sacrifice of objective 1 brings sufficient improvement to objective 2, it is essential that objective 3 does not get worse, then the solution with bigger value of objective 1 is preferred. The start time slots of appliances corresponding to  $F^*$  will be adopted and the EMC will automatically control the home appliances according to the obtained start time slots.

It is noted that the Pareto approach does not depend on the importance factors and the importance factors are taken into account for the final decision making among the Pareto-optimal solutions. This is different from the Weigh approach which relates the importance factors to the values of the objectives, whilst the proposed method of decision making connects the importance factors with the variations of the objectives.

## 6. Simulation results

In this section, the Pareto approach is compared with the Weigh approach and the Constraint approach in the performance of solving the MODSS and the relationships between the operational safety and other objectives are investigated. Eight typical appliances are considered and some appliances are used more than once in a day, and the parameters of the appliances are shown in Table 1 [6, 27]. It is assumed that the users' at-home status and awake status are as shown in Fig. 5. The day-ahead real-time pricing data on August 3rd 2012 is adopted from the Ameren Illinois Power Company

Table 1: Parameters of appliances

Appliance	OTI	LOT	Power (kW)
Rice cooker <sup>1</sup>	1-40	2	0.5
Rice cooker <sup>2</sup>	56-65	2	0.5
Rice cooker <sup>3</sup>	71-90	2	0.5
Water heater	86-105	3	1.5
Dishwasher	101-120	2	0.6
Washing machine	1-60	5	0.38
Electric kettle <sup>1</sup>	1-40	1	1.5
Electric kettle <sup>2</sup>	81-90	1	1.5
Clothes dryer	71-90	5	0.8
Oven	71-90	3	1.9
Electric radiator <sup>1</sup>	56-65	5	1.8
Electric radiator <sup>2</sup>	81-110	20	1.8

\*<sup>1</sup>, \*<sup>2</sup> and \*<sup>3</sup> denote that appliance \* is used three times within different OTIs in one day.

[28]. Both the parameters  $\rho_a$  and  $\sigma_a$ ,  $a = \{1, 2, \dots, n\}$ , are assumed to be 2 [6, 7]. It is noted that the users' at-home status and awake status in Fig. 5 are illustrated to show how the users' statuses are taken into account in the appliances' operational safety, and the at-home status and the awake status are individually defined by users.

### 6.1. Comparison between the Pareto approach and the Weigh approach

The Pareto approach is compared with the Weigh approach under three situations: minimizations of operational unsafety and electricity cost, minimizations of operational unsafety and operational delay, and minimizations of all the three objectives. The maximum generation number was set to be 200 for the NSGA-II of the Pareto approach under the three situations, and the population sizes were set to be 100 and 1000 for the situation considering two objectives and the situation considering three objectives, respectively [24]. For the GA of the Weigh approach, the maximum generation number was 200 and the population size was set to be 2000 for all the situations [29].

#### 6.1.1. Considering operational unsafety and electricity cost

In this case,  $F(X) = (f_1(X), f_2(X))$  for the Pareto approach, and  $w_3 = 0$ ,  $w_1 + w_2 = 1$  for the Weigh approach. Fig. 6 shows the objective values of



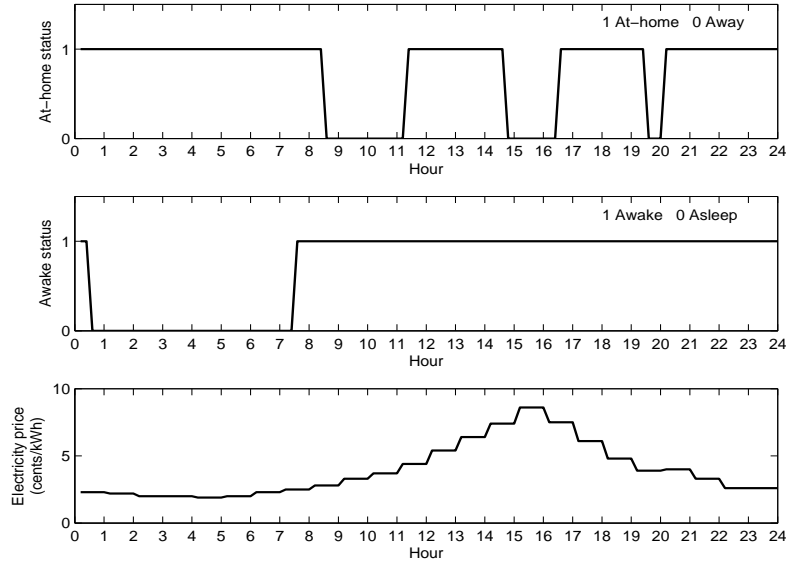

Fig. 5: Users' at-home status, awake status and electricity price during the day

optimal solutions obtained through the Pareto approach and the Weigh approach taking into account the operational unsafety and the electricity cost. The Pareto-optimal front shows that the operational unsafety is reduced with the sacrifice of the electricity cost. The Weigh approach proposes only an optimal solution based on a certain set of importance factors of multiple objectives provided by users while the Pareto approach provides a set of optimal solutions. The multiple solutions of the Weigh approach in Fig. 6 are obtained with different sets of importance factors, and the operational unsafety and the electricity cost of these solutions with respect to the importance factor  $w_1$  are shown in Fig. 7. The Pareto approach clearly shows the relationship between the sacrifice of one objective and the improvement of the other objective through the Pareto-optimal front, which is not presented by the Weigh approach with a single solution. For example, when the electricity cost increases from 58.29 cents to 58.37 cents, the operational unsafety drops from 15.52 to 14.85, and a 0.14% increase in the electricity cost results in a 4.32% reduction in the operational unsafety. The relationship between the sacrifice of one objective and the improvement of the other objective is clearly shown through the Pareto-optimal front, which

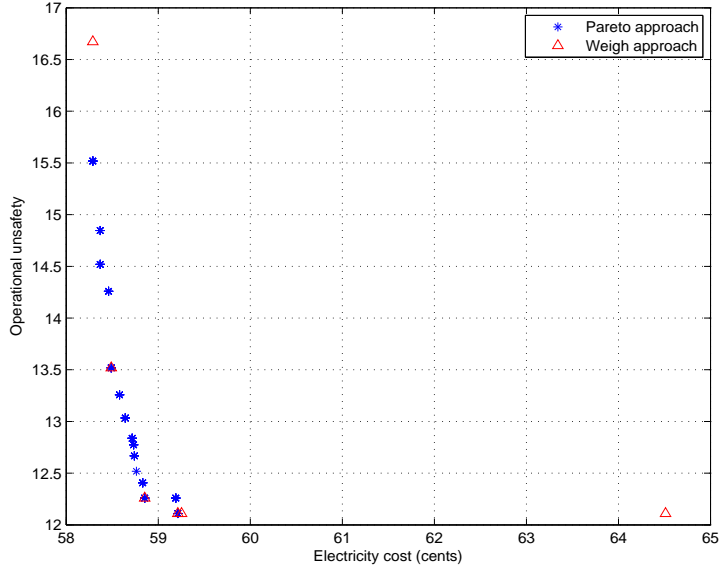

Fig. 6: Comparison between the Pareto approach and the Weigh approach considering the operational unsafety and the electricity cost

provides more information to make the decision of demand side scheduling.

It is noted that though the Weigh approach can provide a set of optimal solutions through multiple runs with different sets of importance factors, the Pareto approach provides the Pareto-optimal front with a single run. Moreover, the Pareto approach deals with noncommensurable objectives directly, and these objectives need transforming to be commensurable through the Weigh approach.

### 6.1.2. Considering operational unsafety and operational delay

In this case,  $F(X) = (f_1(X), f_3(X))$  for the Pareto approach, and  $w_2 = 0$ ,  $w_1 + w_3 = 1$  for the Weigh approach. Fig. 8 shows the objective values of optimal solutions obtained through the Pareto approach and the Weigh approach taking into account the operational unsafety and the operational delay. The Pareto-optimal front shows that the operational unsafety is reduced with the sacrifice of the operational delay, which is not presented by the Weigh approach with a single solution. The multiple solutions of the Weigh approach in Fig. 8 are obtained with different sets of importance factors. The op-

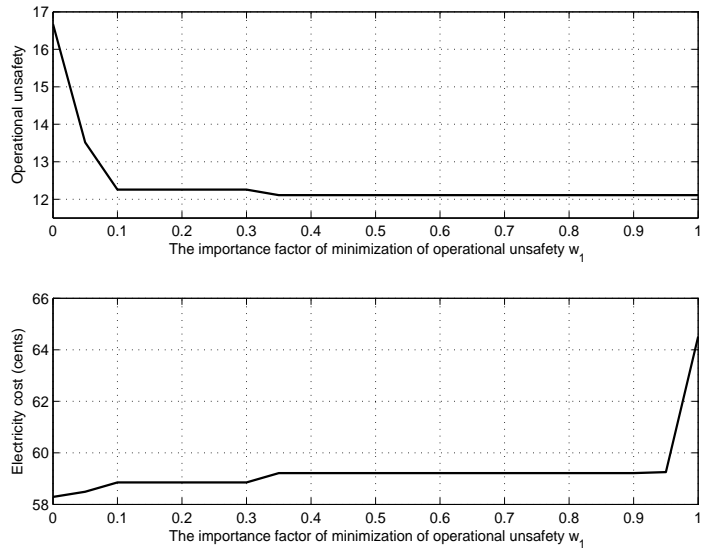

Fig. 7: Operational unsafety and electricity cost with respect to  $w_1$

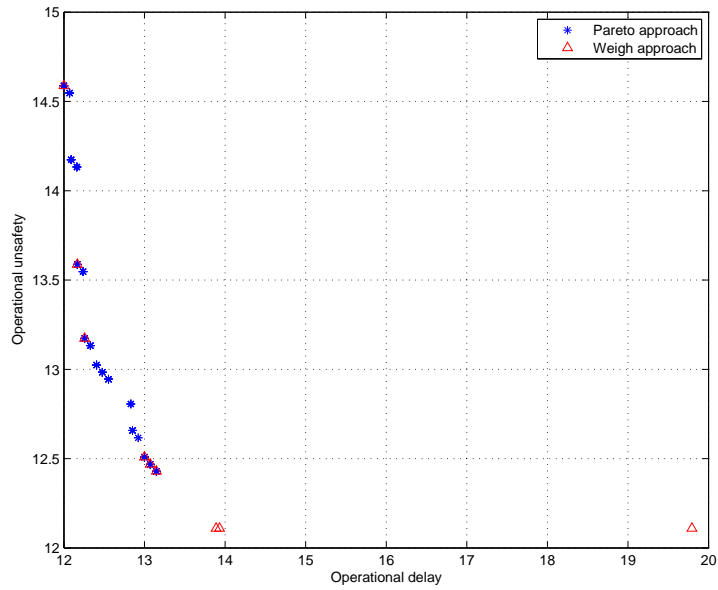

Fig. 8: Comparison between the Pareto approach and the Weigh approach considering the operational unsafety and the operational delay

erational unsafety and the operational delay of these solutions with respect to the importance factor  $w_1$  are similar as the operational unsafety and the electricity cost in Fig. 7, thus they are not presented.

### 6.1.3. Considering operational unsafety, electricity cost and operational delay

In this case,  $F(X) = (f_1(X), f_2(X), f_3(X))$  for the Pareto approach, and  $w_1 + w_2 + w_3 = 1$  for the Weigh approach. Fig. 9 and Fig. 10 show the objective values of solutions obtained through the Pareto approach and the Weigh approach taking into account the operational unsafety, the electricity cost and the operational delay. 100 cases of the Weigh approach are illustrated with the importance factors  $w_1, w_2, w_3$  randomly chosen satisfying  $w_1 + w_2 + w_3 = 1$ . Fig. 10 is the top view of Fig. 9, and the color gradients indicate different values of the electricity cost. The Pareto approach provides a set of optimal solutions with the relationships among the three objectives presented while the Weigh approach only obtains one solution. The multiple solutions of the Weigh approach in Fig. 9 and Fig. 10 are obtained with different sets of importance factors. It can be seen from Fig. 9 and Fig. 10 that the operational unsafety and the operational delay are reduced with the sacrifice of the electricity cost as the electricity cost increases in the decreasing directions of the operational unsafety and the operational delay. The relationship between the operational unsafety and the operational delay is shown in Fig. 9 and Fig. 10. With the electricity cost fixed, the operational unsafety decreases in the increasing direction of the operational delay, which indicates that the operational safety is improved with the sacrifice of the operational delay.

## 6.2. Comparison between the Pareto approach and the Constraint approach

In this section, the Pareto approach is compared with the Constraint approach with the consideration of the operational safety, together with one or both of the electricity cost and the operational delay. The maximum generation number and the population size of the NSGA-II for the Pareto approach and those of the GA for the Constraint approach are set as the same in the comparison between the Pareto approach and the Weigh approach.

### 6.2.1. Considering operational unsafety and electricity cost

In this case,  $F(X) = (f_1(X), f_2(X))$  for the Pareto approach, and the two situations, the minimization of the operational unsafety with the constraint of the electricity cost and the minimization of the electricity cost with

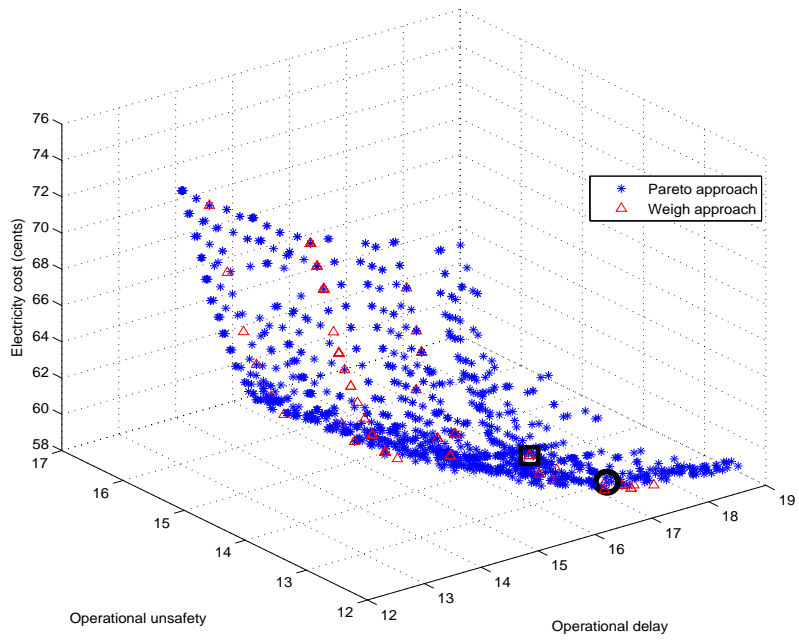

Fig. 9: Comparison between the Pareto approach and the Weigh approach considering the operational unsafety, the electricity cost and the operational delay

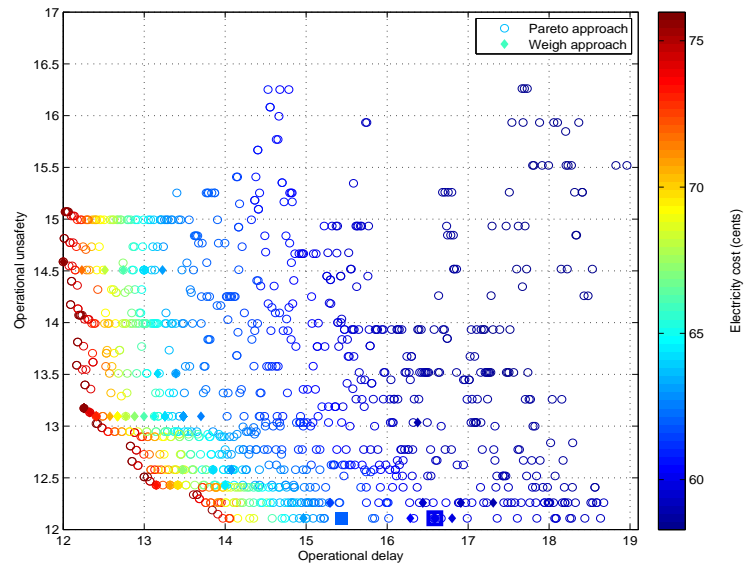

Fig. 10: Top view of comparison between the Pareto approach and the Weigh approach considering the operational unsafety, the electricity cost and the operational delay

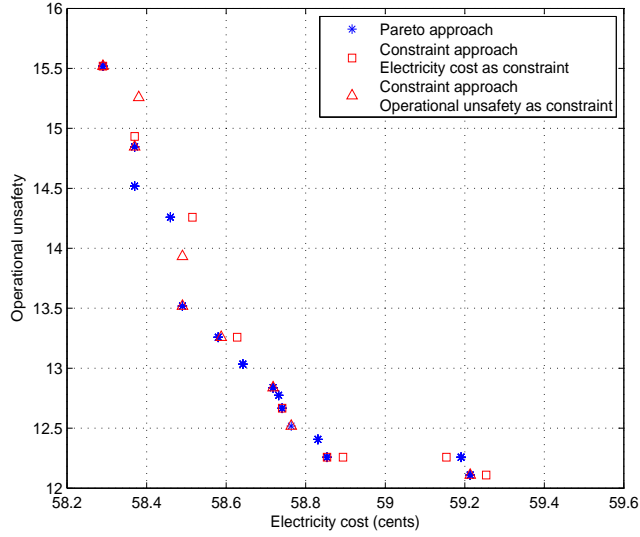

Fig. 11: Comparison between the Pareto approach and the Constraint approach considering the operational unsafety and the electricity cost

the constraint of the operational unsafety are considered for the Constraint approach. Fig. 11 shows the comparison between the Pareto approach and the Constraint approach taking into account the operational unsafety and the electricity cost. Blue stars denote the Pareto approach in Fig. 11, red squares represent the results of the Constraint approach where the operational unsafety is minimized under the condition that the deviation of the electricity cost from its optimal value is within a certain range, and red triangles denote the results of the Constraint approach where the electricity cost is minimized with the constraint of the operational unsafety. The operational unsafety and the electricity cost with respect to the constraint factor  $\eta_2$  in the first situation of the Constraint approach are shown in Fig. 12. The situation where the operational unsafety is minimized with the constraint of the electricity cost is similar to the situation where the electricity cost is minimized with the constraint of the operational unsafety, and the simulation results of the first situation are presented as an example.

The Pareto approach provides a set of optimal solutions while the Constraint approach proposes only an optimal solution and the relationship between the operational safety and the electricity cost is presented through

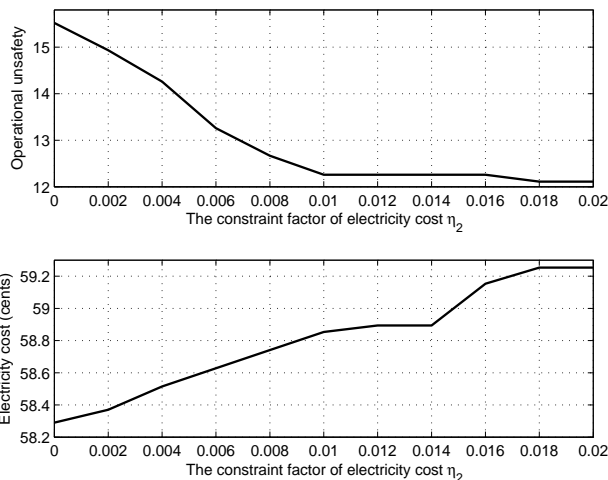

Fig. 12: Operational unsafety and electricity cost with respect to  $\eta_2$

the Pareto approach. The operational safety is improved with the sacrifice of the electricity cost. It is noted that multiple solutions of the Constraint approach shown in Fig. 11 are obtained with different constraints and constraint factors. Moreover, it can be seen from Fig. 11 that some solutions proposed via the Constraint approach are in the upper right of the Pareto-optimal front, i.e., these solutions can be dominated by solutions proposed via the Pareto approach since the Constraint approach does not optimize the objectives in the constraints as long as the deviations of these objectives from their corresponding optimal values are within certain ranges. For example, the operational unsafety is minimized with the constraint of the electricity cost, i.e.,  $\min_X f_1(X)$ , subject to  $f_2(X) \leq (1 + \eta_2)f_2$ . For the two sets of appliances' start time slots  $X_1$  and  $X_2$ , it is assumed that  $f_1(X_1) = f_1(X_2)$ ,  $f_2(X_1) \leq (1 + \eta_2)f_2$ ,  $f_2(X_2) \leq (1 + \eta_2)f_2$ , and  $f_2(X_1) < f_2(X_2)$ . The Constraint approach does not guarantee  $X_1$  is selected with priority even though  $f_1(X_1) = f_1(X_2)$  and  $f_2(X_1) < f_2(X_2)$ .

### 6.2.2. Considering operational unsafety and operational delay

In this case,  $F(X) = (f_1(X), f_3(X))$  for the Pareto approach, and the two situations, the minimization of the operational unsafety with the constraint of the operational delay and the minimization of the operational delay with the constraint of the operational unsafety are considered for the Constraint



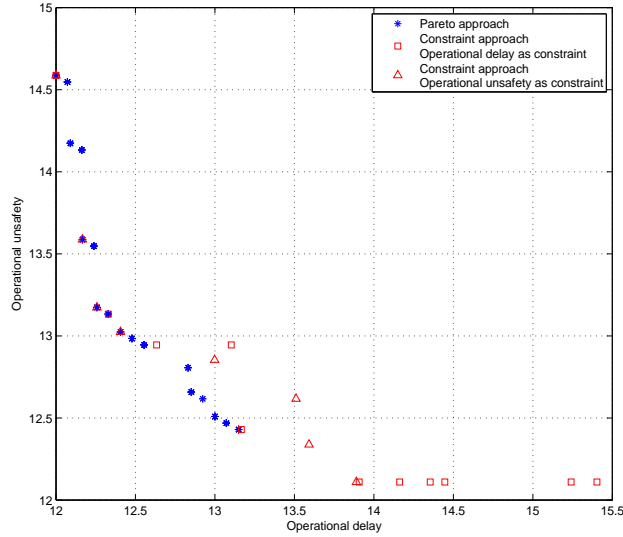

Fig. 13: Comparison between the Pareto approach and the Constraint approach considering the operational unsafety and the operational delay

approach. Fig. 13 shows the comparison between the Pareto approach and the Constraint approach taking into account the operational unsafety and the operational delay. Blue stars denote the Pareto approach in Fig. 13, red squares represent the results of the Constraint approach where the operational unsafety is minimized under the condition that the deviation of the operational delay from its optimal value is within a certain range, and red triangles denote the results of the Constraint approach where the operational delay is minimized with the constraint of the operational unsafety. It can be seen from Fig. 13 that the operational safety is improved with the sacrifice of the operational delay and that some solutions of the Constraint approach are dominated by solutions proposed via the Pareto approach. As the operational unsafety and the operational delay of the Constraint approach with respect to the constraint factor  $\eta_3$  are similar as the operational unsafety and the electricity cost shown in Fig. 12, thus they are not presented.

### 6.2.3. Considering operational unsafety, electricity cost and operational delay

In this case,  $F(X) = (f_1(X), f_2(X), f_3(X))$  for the Pareto approach, and three situations, where one of the three objectives is minimized with the con-

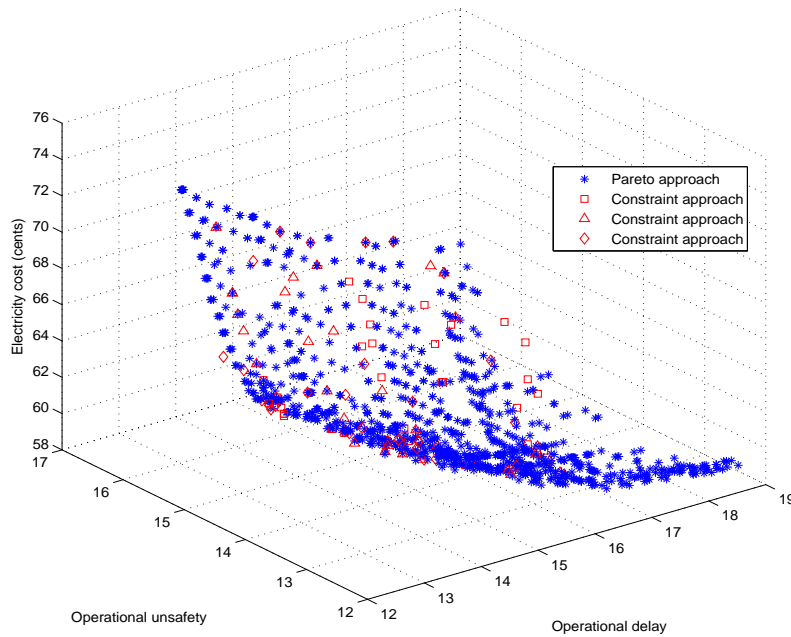

Fig. 14: Comparison between the Pareto approach and the Constraint approach considering the operational unsafety, the electricity cost and the operational delay

straints of the other two objectives, are taken into account for the Constraint approach. Fig. 14 and Fig. 15 show the objective values of optimal solutions obtained by the Pareto approach and the Constraint approach taking into account the operational unsafety, the electricity cost and the operational delay. Squares, triangles and diamonds denote the results of the Constraint approach where the operational unsafety, the operational delay and the electricity cost are minimized with the constraints of the other two objectives, respectively. For each situation of the Constraint approach, 33 cases are illustrated where the constraint factors are randomly chosen within  $[0, 0.3]$ . Fig. 15 is the top view of Fig. 14, where the color gradients indicate the different electricity costs.

The Pareto approach provides a set of optimal solutions while the Constraint approach proposes only an optimal solution, and the multiple solutions of the Constraint approach in Fig. 14 and Fig. 15 are obtained with different constraints and constraint factors. It can be seen from Fig. 14

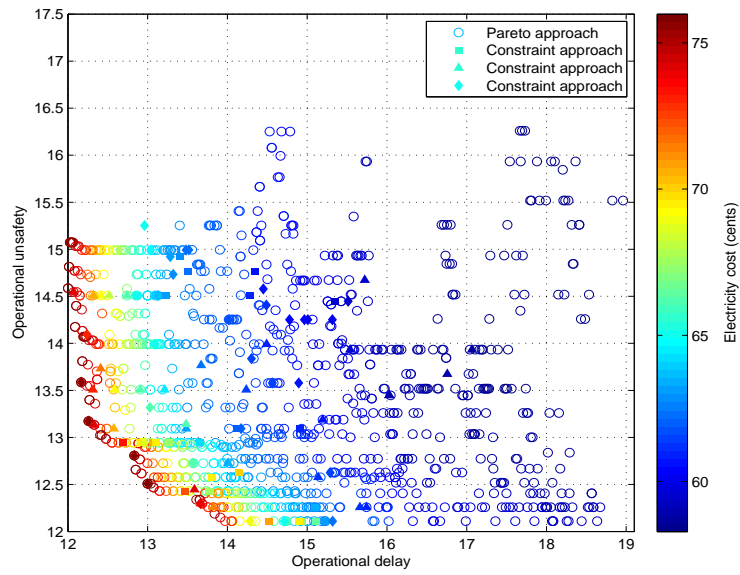

Fig. 15: Top view of comparison between the Pareto approach and the Constraint approach considering the operational unsafety, the electricity cost and the operational delay

and Fig. 15 that the operational unsafety and the operational delay are reduced with the sacrifice of the electricity cost and that the operational safety is improved with the sacrifice of the operational delay. Moreover, Fig. 15 shows that some solutions of the Constraint approach can be dominated by solutions proposed by the Pareto approach as the electricity cost of the Constraint approach is larger than that of the Pareto approach.

### 6.3. Final decision making of the Pareto approach

Through the proposed method of decision making of the Pareto approach, the final solution obtained is illustrated under the situation that the operational safety is considered as the most important objective, the electricity cost as the second important and the operational delay the last, i.e.,  $w_1 = 11/18, w_2 = 5/18$  and  $w_3 = 1/9$ , and this solution is compared with the solution proposed by the Weigh approach with the same importance factors. As shown in Table 2, the operational unsafety, the electricity cost and the operational delay of the Pareto approach are 12.11, 59.99 cents and 16.59, respectively, and this solution is the one highlighted with a black circle shown in Fig. 9, corresponding to the solution in the blue hollow square in Fig. 10, while the solution proposed by the Weigh approach is the one in the black square in Fig. 9 with operational unsafety 12.11, electricity cost 61.89 cents and operational delay 15.44, corresponding to the solution in the solid light blue square in Fig. 10. Compared with the solution based on the Pareto approach, the operational unsafety is the same, the electricity cost is greater and the operational delay is less for the solution of the Weigh approach. The relationship between the sacrifice of the electricity cost and the improvement of the operational delay is presented according to (14)

$$\begin{aligned}
& \frac{(f_3^P - f_3^W)/(f_3^{\max} - f_3^{\min})}{(f_2^W - f_2^P)/(f_2^{\max} - f_2^{\min})} \\
= & \frac{(16.59 - 15.44)/(18.96 - 12.00)}{(61.89 - 59.99)/(75.98 - 58.29)} \\
= & 1.54
\end{aligned} \tag{15}$$

where  $f_2^P$  and  $f_3^P$  are the electricity cost and the operational delay of the Pareto approach, respectively,  $f_2^W$  and  $f_3^W$  are the cost and the operational delay of the Weigh approach, and  $f_2^{\max} = 75.98, f_2^{\min} = 58.29, f_3^{\max} = 18.96, f_3^{\min} = 12.00$  are the bounds of electricity cost and operational delay. The electricity cost is 2.50 times more important than the operational delay and  $1.54 < 2.50$  shows that the sacrifice of the electricity cost does not

Table 2: Comparison of final solution between the Pareto approach and the Weigh approach

Approach	Operational unsafety	Electricity cost (cents)	Operational delay
Pareto approach	12.11	59.99	16.59
Weigh approach	12.11	61.89	15.44

bring sufficient improvement of the operational delay comparing the solution of the Weigh approach with that of the Pareto approach. Therefore, the solution based on the Pareto approach with the same operational unsafety and reduced electricity cost is preferred according to the proposed method of final decision making. The start time slots of the appliances in Table 1 are 1, 57, 71, 95, 101, 38, 1, 86, 86, 86, 57 and 91, respectively, corresponding to the solution based on the Pareto approach.

With the development of the information and communication technology, it will become more convenient for users to acquire the electricity price information from the utility company [7], and the cost of the energy management system including the EMC, the home area network and smart home appliances will be decreasing [30]. Moreover, the proposed approach is to improve an installed energy management system via upgrading scheduling programming of the EMC, thus no extra hardware cost is needed. After the EMC works out and updates the energy consumption schedules based on the electricity price and users' demands and status, the home appliances will be automatically controlled according to the obtained schedules through the home area network.

## 7. Conclusions

In this paper, the operational safety of appliances has been considered during the demand side scheduling along with the electricity cost and the operational delay. The Pareto approach is adopted to solve the problem of MODSS and to present the relationships between the operational safety and the other two objectives. Then this approach has been compared with the Weigh approach and the Constraint approach in the performance of multi-objective optimization. Simulation results have demonstrated that the Pareto approach clearly presents the relationships between the operational

safety and the other two objectives through the Pareto-optimal front compared with the Weigh approach. The operational safety is improved with the sacrifice of the electricity cost and the operational delay. Compared with the Constraint approach, the solutions proposed by the Pareto approach are better. Furthermore, a method of making scheduling decision has been proposed based on the Pareto approach with the consideration of the relationships among multiple objectives. Taking into account the appliances' operational safety, the Pareto approach has proved effective in presenting comprehensive optimal solutions to the multi-objective demand side scheduling.

## 8. Acknowledgment

This work is supported in part by Engineering Physical Science Research Council UK (EP/M507192/1) and in part by National Natural Science Foundation of China under Grant No. 51428702.

## References

- [1] U.S. Department of Energy, Benefits of demand response in electricity markets and recommendations for achieving them (2006). URL [http://www.hyperspeedplc.com/Documents/Report\\_on\\_Demand\\_Response\\_2006.pdf](http://www.hyperspeedplc.com/Documents/Report_on_Demand_Response_2006.pdf).
- [2] P. Siano, D. Sarno, Assessing the benefits of residential demand response in a real time distribution energy market, *Applied Energy* 161 (2016) 533 – 551. doi:<http://dx.doi.org/10.1016/j.apenergy.2015.10.017>.
- [3] Z. Bie, H. Xie, G. Hu, G. Li, Optimal scheduling of power systems considering demand response, *Journal of Modern Power Systems and Clean Energy* 4 (2) (2016) 180–187. doi:[10.1007/s40565-015-0136-9](https://doi.org/10.1007/s40565-015-0136-9).
- [4] C. Wang, Y. Zhou, J. Wu, J. Wang, Y. Zhang, D. Wang, Robust-index method for household load scheduling considering uncertainties of customer behavior, *IEEE Transactions on Smart Grid* 6 (4) (2015) 1806–1818. doi:[10.1109/TSG.2015.2403411](https://doi.org/10.1109/TSG.2015.2403411).
- [5] A. Giusti, M. Salani, G. Di Caro, A. Rizzoli, L. Gambardella, Restricted neighborhood communication improves decentralized demand-side load management, *IEEE Transactions on Smart Grid* 5 (1) (2014) 92–101. doi:[10.1109/TSG.2013.2267396](https://doi.org/10.1109/TSG.2013.2267396).

- [6] Z. Zhao, W. C. Lee, Y. Shin, K. B. Song, An optimal power scheduling method for demand response in home energy management system, *IEEE Transactions on Smart Grid* 4 (3) (2013) 1391–1400. doi:10.1109/TSG.2013.2251018.
- [7] A. H. Mohsenian-Rad, A. Leon-Garcia, Optimal residential load control with price prediction in real-time electricity pricing environments, *IEEE Transactions on Smart Grid* 1 (2) (2010) 120–133. doi:10.1109/TSG.2010.2055903.
- [8] A. Anvari-Moghaddam, H. Monsef, A. Rahimi-Kian, Optimal smart home energy management considering energy saving and a comfortable lifestyle, *IEEE Transactions on Smart Grid* 6 (1) (2015) 324–332. doi:10.1109/TSG.2014.2349352.
- [9] H. G. Kwag, J. O. Kim, Reliability modeling of demand response considering uncertainty of customer behavior, *Applied Energy* 122 (2014) 24 – 33. doi:http://dx.doi.org/10.1016/j.apenergy.2014.01.068.
- [10] S. Behboodi, D. P. Chassin, C. Crawford, N. Djilali, Renewable resources portfolio optimization in the presence of demand response, *Applied Energy* 162 (2016) 139 – 148. doi:http://dx.doi.org/10.1016/j.apenergy.2015.10.074.
- [11] R. Ma, K. Li, X. Li, Z. Qin, An economic and low-carbon day-ahead Pareto-optimal scheduling for wind farm integrated power systems with demand response, *Journal of Modern Power Systems and Clean Energy* 3 (3) (2015) 393–401. doi:10.1007/s40565-014-0094-7.
- [12] Wholesale Solar, Power for home appliances (2012). URL <http://www.electricalsafetyfirst.org.uk/news-and-campaigns/policies-and-research/statistics/>.
- [13] U.S. Fire Administration, Residential building fires, causes and dollar loss (2014). URL [http://www.usfa.fema.gov/downloads/xls/statistics/residential\\_nonresidential\\_fire\\_loss\\_estimates.xlsx](http://www.usfa.fema.gov/downloads/xls/statistics/residential_nonresidential_fire_loss_estimates.xlsx).
- [14] S. Salinas, M. Li, P. Li, Multi-objective optimal energy consumption scheduling in smart grids, *IEEE Transactions on Smart Grid* 4 (1) (2013) 341–348. doi:10.1109/TSG.2012.2214068.

- [15] Y. H. Lin, M. S. Tsai, An advanced home energy management system facilitated by nonintrusive load monitoring with automated multiobjective power scheduling, *IEEE Transactions on Smart Grid* 6 (4) (2015) 1839–1851. doi:10.1109/TSG.2015.2388492.
- [16] N. Yaagoubi, H. Mouftah, User-aware game theoretic approach for demand management, *IEEE Transactions on Smart Grid* 6 (2) (2015) 716–725. doi:10.1109/TSG.2014.2363098.
- [17] Ameren, Day ahead pricing used for billing RTP service (2016). URL <https://www2.ameren.com/RetailEnergy/RealTimePrices>.
- [18] O. Erdinc, Economic impacts of small-scale own generating and storage units, and electric vehicles under different demand response strategies for smart households, *Applied Energy* 126 (2014) 142 – 150. doi:http://dx.doi.org/10.1016/j.apenergy.2014.04.010.
- [19] C. B. Kobus, E. A. Klaassen, R. Mugge, J. P. Schoormans, A real-life assessment on the effect of smart appliances for shifting households electricity demand, *Applied Energy* 147 (2015) 335 – 343. doi:http://dx.doi.org/10.1016/j.apenergy.2015.01.073.
- [20] P. S. Kwon, P. stergaard, Assessment and evaluation of flexible demand in a Danish future energy scenario, *Applied Energy* 134 (2014) 309 – 320. doi:http://dx.doi.org/10.1016/j.apenergy.2014.08.044.
- [21] A. D. Giorgio, F. Liberati, Near real time load shifting control for residential electricity prosumers under designed and market indexed pricing models, *Applied Energy* 128 (2014) 119 – 132. doi:http://dx.doi.org/10.1016/j.apenergy.2014.04.032.
- [22] K. Deb, A. Pratap, S. Agarwal, T. Meyarivan, A fast and elitist multiobjective genetic algorithm: NSGA-II, *IEEE Transactions on Evolutionary Computation* 6 (2) (2002) 182–197. doi:10.1109/4235.996017.
- [23] H. S. Shih, A mixed-data evaluation in group TOPSIS with differentiated decision power, *Group Decision and Negotiation* (2015) 1–29.
- [24] C. Guo, J. Zhan, Q. Wu, Dynamic economic emission dispatch based on group search optimizer with multiple producers, *Electric Power Systems Research* 86 (2012) 8 – 16. doi:http://dx.doi.org/10.1016/j.epsr.2011.11.015.



- [25] D. Olson, Comparison of weights in TOPSIS models, *Mathematical and Computer Modelling* 40 (78) (2004) 721 – 727. doi:<http://dx.doi.org/10.1016/j.mcm.2004.10.003>.
- [26] B. S. Ahn, Compatible weighting method with rank order centroid: Maximum entropy ordered weighted averaging approach, *European Journal of Operational Research* 212 (3) (2011) 552 – 559. doi:<http://dx.doi.org/10.1016/j.ejor.2011.02.017>.
- [27] Wholesale Solar, Power for home appliances (2014). URL <http://www.wholesalesolar.com/StartHere/HowtoSaveEnergy/PowerTable.html>.
- [28] Ameren Illinois Power Company, Real-time pricing for residential customers (2012). URL <https://www.powersmartpricing.org/prices/>.
- [29] T. Logenthiran, D. Srinivasan, T. Z. Shun, Demand side management in smart grid using heuristic optimization, *IEEE Transactions on Smart Grid* 3 (3) (2012) 1244–1252. doi:10.1109/TSG.2012.2195686.
- [30] M. T. Vo, M. T. Nguyen, T. D. Nguyen, C. T. Le, H. T. Huynh, Towards residential smart grid: A practical design of wireless sensor network and mini-web server based low cost home energy monitoring system, in: *2013 International Conference on Advanced Technologies for Communications (ATC 2013)*, 2013, pp. 540–545. doi:10.1109/ATC.2013.6698174.