

Parameter Selection and Covariance Updating

Tiago AN Silva^{1,2}, Nuno MM Maia², Michael Link³ and John E Mottershead^{4,5}

¹*Instituto Superior de Engenharia de Lisboa, Lisbon, Portugal.*

²*LAETA, IDMEC, Instituto Superior Técnico, University of Lisbon, Portugal.*

³*Institute for Statics and Dynamics, University of Kassel, Germany.*

⁴*Centre for Engineering Dynamics, University of Liverpool, UK.*

⁵*Institute for Risk and Uncertainty, University of Liverpool, UK.*

j.e.mottershead@liverpool.ac.uk

ABSTRACT

A simple expression is developed for covariance-matrix correction in stochastic model updating. The need for expensive forward propagation of uncertainty through the model is obviated by application of a formula based only on the sensitivity of the outputs at the end of a deterministic updating process carried out on the means of the parameters. Two previously published techniques are shown to reduce to the same simple formula within the assumption of small perturbation about the mean. It is shown, using a simple numerical example, that deterministic updating of the parameter means can result in correct reconstruction of the output means even when the updating parameters are wrongly chosen. If the parameters are correctly chosen, then the covariance matrix of the outputs is correctly reconstructed, but when the parameters are wrongly chosen it is found that the output covariance is generally not reconstructed accurately. Therefore, the selection of updating parameters on the basis of reconstructing the output means is not sufficient to ensure that the output covariances will be well reconstructed. Further theory is then developed by assessing the contribution of each candidate parameter to the output covariance matrix, thereby enabling the selection of updating parameters to ensure that both the output means and covariances are reconstructed by the updated model. This latter theory is supported by further numerical examples.

Keywords: Stochastic model updating, covariance matrix, parameter selection.

1.0 Introduction

One of the first attempts to address the problem of updating or ‘correcting’ finite element models was the statistical approach proposed by Collins, Hart, Hasselman and Kennedy in 1974 [1]. Since that time much attention has been concentrated mainly on deterministic model updating methods, including particularly parameterisation of finite element models for updating and regularisation of the generally ill-posed model-updating problem. Details can be found in references [2-4]. Very recently, new research has addressed the problem of stochastic model updating, which we review briefly in the following paragraphs.

Jacquelin et al. [5] developed a model updating technique using random matrix theory resulting in a mean stiffness and covariance matrix representing the structural uncertainty in a global way from measured variability in natural frequencies and modes shapes. Adhikari and Friswell [6] used a sensitivity approach to update distributed parameters, typically the bending rigidity EI of a beam, represented as random fields using the Karhunen-Loève expansion. Goller et al. [7] addressed the problem of insufficient information by the application of multi-dimensional Gaussian kernel densities derived from sparse modal data. This allowed design insensitivity to be quantified, so that the proposed method could be said to be robust. Mthembu et al. [8] used Bayesian evidence for model selection.

Early examples of Bayesian model updating include the work of Beck and Katafygiotis [9, 10] whereby experimental data is used to progressively revise the updating parameters expressed by a posterior probability density function. One problem with the Bayesian approach has been the large computational effort associated with sampling using Markov chain Monte-Carlo (MCMC) algorithms. This has now been largely overcome as demonstrated by Goller et al. [11] using parallelisation of the updating code together with the transitional MCMC algorithm, which identifies parameter regions with the highest posterior probability mass. Zhang et al. [12] used the polynomial chaos expansion as a surrogate for the full FE model as well as an evolutionary MCMC algorithm where a population of chains is updated by mutation to avoid being trapped in local basins of attraction.

The problem of variability in the dynamics of nominally identical test pieces seems to have been addressed first by Mares et al. [13, 14] using a multivariate gradient-regression approach. This was combined with a minimum variance estimator so that the means of the resulting distributions represented the most likely parameters of a next-tested structure and the standard deviations could be interpreted as indicators of confidence in the means. Hua et al. [15] were the first to consider the uncertainty of multiple nominally-identical test pieces from the frequentist viewpoint, where the distribution is meaningful in terms of the ‘spread’ of updating parameters. They used a perturbation approach, as did Haddad Khodaparast et al. [16], the latter showing excellent results using first-order perturbation whereas the method described in [15] required the computation of second-order sensitivities. Govers and Link [17] extended the classical sensitivity model-updating method by a Taylor series expansion of the analytical output covariance matrix and obtained parameter mean values and covariances. This technique has since been demonstrated very effectively, and compared to an interval updating method [18], using data obtained by repeated disassembly and reassembly of the DRL AIRMOD structure [19, 20]. Fang et al. [21, 22] used a response-surface surrogate for the full FE model together with Monte-Carlo simulation (MCS). Hypothesis testing by analysis of variance (ANOVA) using the statistical F -test evaluation was applied to determine the contribution of each updating parameter (or a group of parameters) to the total variance of each measured output. If the F -test returned a value that exceeded a threshold, then the chosen parameter was deemed to contribute significantly to the variance of the output.

In this paper, a simple formula is developed for covariance updating that can be applied without the use of expensive forward propagation by MCS to determine the output covariance matrix. Two previous stochastic model updating methods are shown to be equivalent to the same formula with the assumption of small perturbations about the mean. It is demonstrated using a 3-degree of freedom model that the choice of updating parameters is critical to this process. If the correct parameters are chosen, then the output covariance matrix is reconstructed faithfully. However, this is generally not the case when wrongly chosen parameters are used, even though the output means may be accurately reconstructed. It is shown that the scaled output covariance matrix may be decomposed to allow the contributions of each candidate parameter to be assessed. Use of the classical linearised sensitivity

permits the assessment to be carried out efficiently. Numerical examples are used to illustrate the performance of the technique.

2.0 Updating the Covariance Matrix

The stochastic model updating problem may be expressed as,

$$(\mathbf{z}^e - \bar{\mathbf{z}}^e) = \bar{\mathbf{S}}_j (\boldsymbol{\theta} - \bar{\boldsymbol{\theta}})_{j+1} + \boldsymbol{\varepsilon}_{j+1} \quad (1)$$

by the assumption of small perturbation about the mean. In equation (1) the over-bar denotes the mean, $\mathbf{z}^e, \bar{\mathbf{z}}^e$ are experimentally measured outputs, typically natural frequencies and mode-shape terms, $\boldsymbol{\theta}_{j+1}$ is the $(j+1)^{th}$ estimate of parameter distribution to be determined, with mean $\bar{\boldsymbol{\theta}}_{j+1}$. The mean sensitivity matrix is denoted by $\bar{\mathbf{S}}_j = \mathbf{S}(\bar{\boldsymbol{\theta}}_j)$ and $\boldsymbol{\varepsilon}_{j+1}$ represents errors introduced from various sources including inaccuracy of the model and measurement imprecision.

Model updating of the means is a deterministic problem [16, 17] given by,

$$\bar{\boldsymbol{\theta}}_{j+1} = \bar{\boldsymbol{\theta}}_j + \bar{\mathbf{T}}_j (\bar{\mathbf{z}}^e - \bar{\mathbf{z}}_j^a(\bar{\boldsymbol{\theta}}_j)) \quad (2)$$

where $\bar{\mathbf{z}}_j^a(\bar{\boldsymbol{\theta}}_j)$ is the a predicted output of the model at the j^{th} iteration. The transformation matrix $\bar{\mathbf{T}}_j$ is the generalised pseudo inverse of the sensitivity matrix $\bar{\mathbf{S}}_j$,

$$\bar{\mathbf{T}}_j = (\bar{\mathbf{S}}_j^T \mathbf{W}_\varepsilon \bar{\mathbf{S}}_j + \mathbf{W}_\vartheta)^{-1} \bar{\mathbf{S}}_j^T \quad (3)$$

and \mathbf{W}_ε and \mathbf{W}_ϑ are weighting matrices, to allow for regularisation of ill-posed sensitivity equations [4].

It is seen from equation (1) that the matrix of output covariances is given by,

$$Cov(\Delta \mathbf{z}^e, \Delta \mathbf{z}^e) = \bar{\mathbf{S}}_j Cov(\Delta \boldsymbol{\theta}_{j+1}, \Delta \boldsymbol{\theta}_{j+1}) \bar{\mathbf{S}}_j^T + Cov(\boldsymbol{\varepsilon}_{j+1}, \boldsymbol{\varepsilon}_{j+1}) \quad (4)$$

$$\Delta \mathbf{z}^e = \mathbf{z}^e - \bar{\mathbf{z}}^e; \quad \Delta \boldsymbol{\theta} = \boldsymbol{\theta} - \bar{\boldsymbol{\theta}}_j \quad (5)$$

Then, if the error covariances are deemed to be small, an estimate of the parameter covariances may be obtained by inversion, using (3) to obtain,

$$Cov(\Delta \boldsymbol{\theta}_{j+1}, \Delta \boldsymbol{\theta}_{j+1}) = \bar{\mathbf{T}}_j Cov(\Delta \mathbf{z}^e, \Delta \mathbf{z}^e) \bar{\mathbf{T}}_j^T \quad (6)$$

Equation (6) allows for the computation of $Cov(\Delta \boldsymbol{\theta}_{j+1}, \Delta \boldsymbol{\theta}_{j+1})$ using only the transformation matrix, $\bar{\mathbf{T}}_j$, obtained at the final step of deterministic updating of the means and the measured output covariance. It avoids expensive forward propagation of uncertainty through the model required by alternative approaches. In Appendix 1 it is shown that equation (6) may be developed

straightforwardly from expressions given previously by Haddad Khodaparast *et al.* [16] and Govers and Link [17].

3.0 Numerical Examples – Covariance Updating

The example considered is the 3 degree of freedom mass-spring system shown in Figure 1 and used in references [13], [16] and [18].

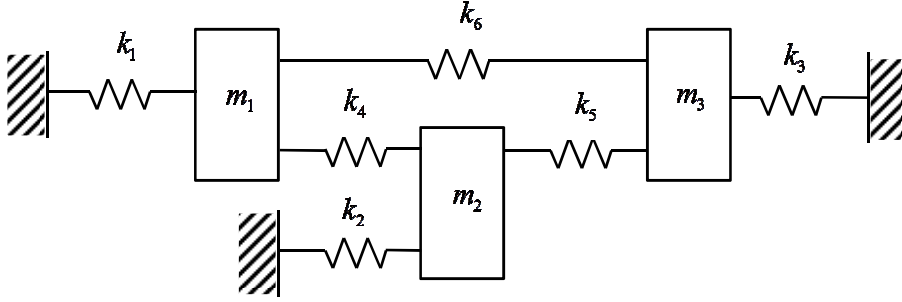

Figure 1. Three degree of freedom mass-spring example

The nominal values of the parameters of the ‘experimental’ system are: $m_i = 1.0 \text{ kg}$ ($i=1,2,3$), $k_i = 1.0 \text{ N/m}$ ($i=1,2,\dots,5$) and $k_6 = 3.0 \text{ N/m}$. The erroneous random parameters are assumed to have Gaussian distributions with mean values, $\mu_{k_1} = \mu_{k_2} = \mu_{k_5} = 2.0 \text{ N/m}$ and standard deviations $\sigma_{k_1} = \sigma_{k_2} = \sigma_{k_5} = 0.3 \text{ N/m}$. The true mean values are the nominal values with standard deviations $\sigma_{k_1} = \sigma_{k_2} = \sigma_{k_5} = 0.2 \text{ N/m}$ (20% of the true mean values). Parameters k_1, k_2 and k_5 are assumed to be independent.

Case 1 – Consistent set of updating parameters

This example comprises a consistent updating problem where three uncertain stiffnesses, k_1, k_2, k_5 , are deemed to be responsible for observed variability in the three natural frequencies of the system. Equations (6) and (20) (Appendix 1) above were applied and the initial cloud of predicted natural frequencies was made to converge upon the cloud of ‘measured’ natural frequencies as shown in Figure 2. The measured data consisted of 30 separate measurement points (30 points in the 3 dimensional space of the natural frequencies) and the predictions were represented by 1000 points, needed for forward propagation by Latin hypercube sampling (LHS) with imposed correlation from a normal distribution $\theta_j \in N_n(\bar{\theta}_j, Cov(\theta_j, \theta_j))$, in order to determine $\Delta \mathbf{z}_j$ from $\Delta \theta_j$.

Figure 2 shows the results produced by the two methods, where it is apparent that the updated covariance ellipses from the two solutions are almost indistinguishable from each other or from the covariance ellipse of the ‘measured’ data. Note that the covariance ellipses on the scatter plots encompass 95% of the data (2-sigma ellipses).

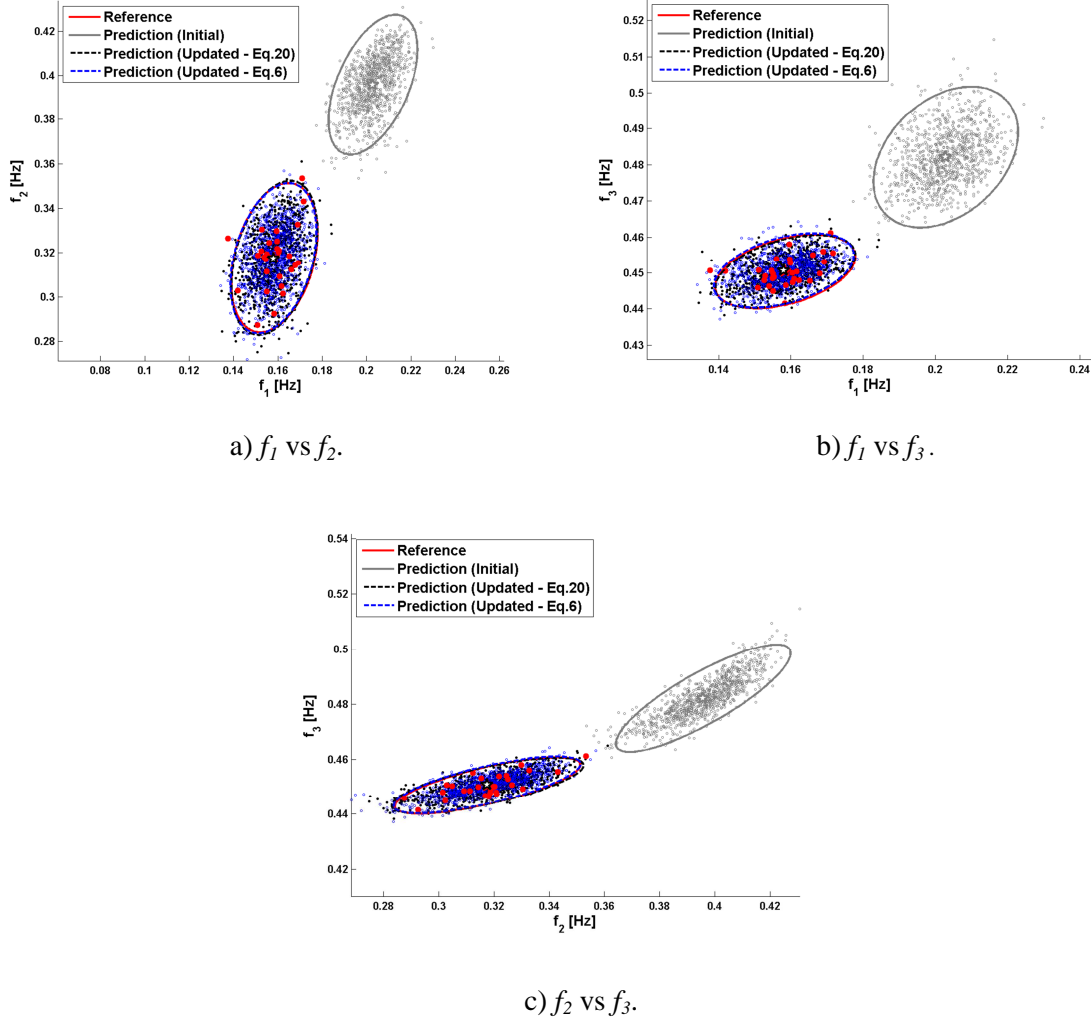

Figure 2. Frequency scatter plots (Case 1).

Typical convergence characteristics are shown in Figure 3 and the updated parameter values are given in Table 1. The adopted convergence criterion was that the deviation of the predicted eigenfrequencies with respect to the reference ones should be less than a specified tolerance.

The CPU times shown in Table 1 are determined with respect to the solution from equation (6). It is seen that for this particular 3 degree of freedom problem, calculation of the parameter covariance matrix is approximately 300 times faster by equation (6) than by equation (20) (Appendix 1).

Updating is carried out using equation (6) for (i) an extended set of updating parameters with noisy data, and (ii) an inconsistent set of wrongly chosen updating parameters in the following Cases 2 and 3.

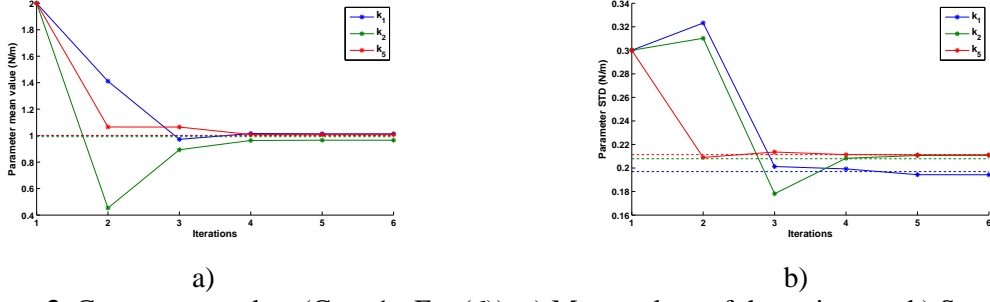

Figure 3. Convergence plots (Case 1 - Eq. (6)): a) Mean values of the estimates; b) Standard deviation of the estimates - (dash-dotted line: reference values).

Table 1. Parameters and eigenfrequencies values.

	Reference 30 obs.	Initial (error %)	Updated (error %) Eq(20) 1000 obs.	Updated (error %) Eq (6)
\bar{k}_1 [N/m]	1.001	2.0 (99.73)	1.001 (-0.03)	1.014 (1.26)
\bar{k}_2 [N/m]	0.992	2.0 (101.55)	0.993 (0.06)	0.966 (-2.68)
\bar{k}_5 [N/m]	1.001	2.0 (99.84)	1.001 (-0.02)	1.008 (0.69)
σ_{k_1} [N/m]	0.197	0.3 (52.59)	0.194 (-1.59)	0.194 (-1.36)
σ_{k_2} [N/m]	0.208	0.3 (44.58)	0.213 (2.35)	0.211 (1.40)
σ_{k_5} [N/m]	0.211	0.3 (41.94)	0.211 (-0.05)	0.211 (-0.11)
f_1 [Hz]	0.1586	0.2030 (28.02)	0.1586 (-0.00)	0.1586 (-0.00)
f_2 [Hz]	0.3180	0.3960 (24.54)	0.3180 (-0.00)	0.3180 (-0.00)
f_3 [Hz]	0.4505	0.4823 (7.06)	0.4505 (-0.00)	0.4505 (0.00)
# Iterations	-	-	9	6
CPU time ratio	-	-	~300	1

Case 2 – Noisy Data

In this case zero-mean Gaussian noise with coefficient of variation (CoV) $[5 \ 5 \ 3]\%$ is added to the measured eigenvalue data and the number of updating parameters is increased from 3 to 5, i.e. k_1, k_2, \dots, k_5 . Here, the erroneous random parameters are assumed to have Gaussian distributions with mean values, $\mu_{k_1} = \mu_{k_2} = \mu_{k_5} = 2.0 \text{ N/m}$ and $\mu_{k_3} = \mu_{k_4} = 0.5 \text{ N/m}$ and standard deviations $\sigma_{k_1} = \sigma_{k_2} = \sigma_{k_5} = 0.3 \text{ N/m}$ and $\sigma_{k_3} = \sigma_{k_4} = 0.1 \text{ N/m}$. It is necessary in this case to include the mode-shape sensitivities in order that the updating equation (1) is overdetermined.

Figure 4 shows good agreement between reference and updated scatter ellipses using a reference sample with 30 observations and an updated LHS of 1000 observations, generated with the updated mean values and covariance matrix.

Typical convergence characteristics are shown in Figure 5, where the standard deviation of the randomized stiffnesses ($\sigma_i = 0.2 \text{ N/m}$) is approximated, but not obtained perfectly. This is because the non-randomized stiffnesses k_3 and k_4 become random variables after updating, as the updated covariance matrix also has components related to these initially non-randomized parameters (Figure 5.b).

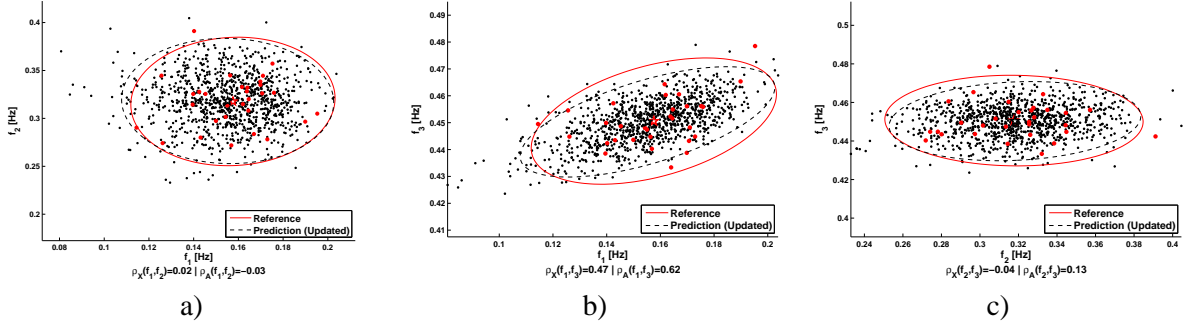

Figure 4. Frequency scatter plots (Case 2 - Eq. (6)).

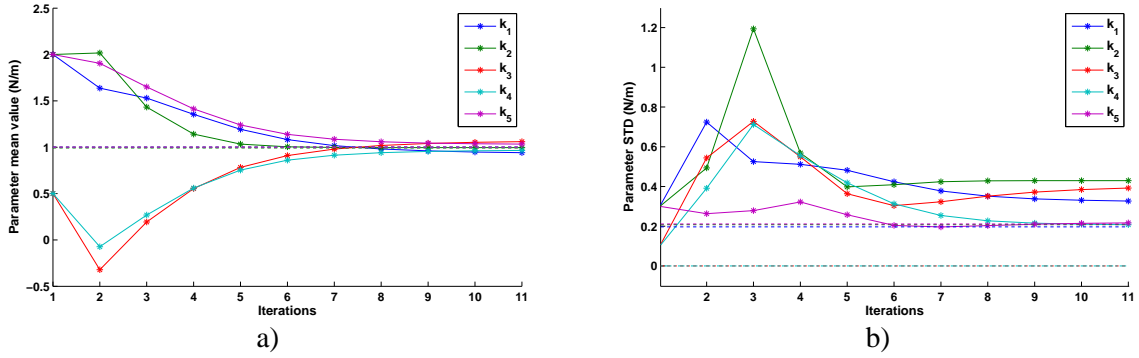

Figure 5. Convergence plots (Case 2 - Eq. (6)): a) Mean values of the estimates; b) Standard deviation of the estimates - (dash-dotted line: reference values).

Case 3 - Inconsistent updating parameter set

Case 3 presents an example of an inconsistent updating problem where the updating parameter set does not include all the uncertain parameters responsible for the observed variability in the reference responses. As in the previous cases, the reference data were produced with randomized k_1, k_2 and k_5 , while the updating parameter set is composed of k_1, k_2 and k_6 , i.e., the uncertain k_5 is not included in the updating parameter set. In this case regularisation was applied with $\mathbf{W}_\rho = \mathbf{I}$, $\mathbf{W}_\varepsilon = 0.1 \times \mathbf{I}$.

Figures 6 and 7 show the results of the updating process - the reference sample is that given in Case 2. The scatter plots of Figure 6 show that the output means are reconstructed faithfully but the choice of an inconsistent set of updating parameters has resulted in large errors in the reconstructed covariance ellipses. The updating parameters k_1, k_2, k_6 are fully converged after 30 iterations as shown in Figure 7. This result demonstrates that the selection of updating parameters on the basis of reconstructing the output means is not sufficient to ensure that the output covariances will be well reconstructed. The problem to be addressed in the following section is, therefore, to define a procedure for parameter selection prior to model updating that ensures that output covariances as well as mean values are reconstructed accurately.

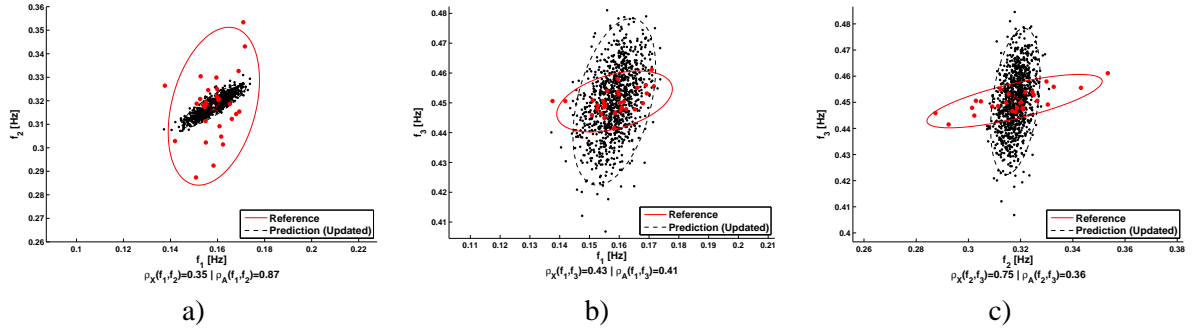

Figure 6. Frequency scatter plots (Case 3 - Eq. (6)).

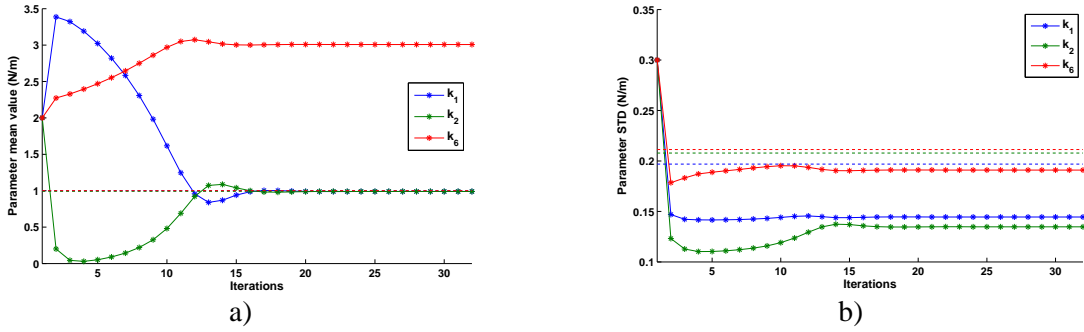

Figure 7. Convergence plots (Case 3 - Eq. (6)): a) Mean values of the estimates; b) Standard deviation of the estimates - (dash-dotted line: reference values).

4.0 Selection of Parameters for Stochastic Model Updating

Equation (1) may be cast in scaled form using the output and parameter standard deviations,

$$\begin{pmatrix} \left(\frac{z_1 - \bar{z}_1}{\sigma_{z_1}} \right) \\ \left(\frac{z_2 - \bar{z}_2}{\sigma_{z_2}} \right) \\ \vdots \\ \left(\frac{z_n - \bar{z}_n}{\sigma_{z_n}} \right) \end{pmatrix} = \begin{bmatrix} \sigma_{\theta_1} \frac{\partial \bar{z}_1}{\partial \theta_1} & \sigma_{\theta_2} \frac{\partial \bar{z}_1}{\partial \theta_2} & \dots & \sigma_{\theta_m} \frac{\partial \bar{z}_1}{\partial \theta_m} \\ \sigma_{z_1} \frac{\partial \bar{\theta}_1}{\partial \bar{z}_1} & \sigma_{z_1} \frac{\partial \bar{\theta}_2}{\partial \bar{z}_1} & \dots & \sigma_{z_1} \frac{\partial \bar{\theta}_m}{\partial \bar{z}_1} \\ \sigma_{\theta_1} \frac{\partial \bar{z}_2}{\partial \theta_1} & \sigma_{\theta_2} \frac{\partial \bar{z}_2}{\partial \theta_2} & \dots & \sigma_{\theta_m} \frac{\partial \bar{z}_2}{\partial \theta_m} \\ \sigma_{z_2} \frac{\partial \bar{\theta}_1}{\partial \bar{z}_2} & \sigma_{z_2} \frac{\partial \bar{\theta}_2}{\partial \bar{z}_2} & \dots & \sigma_{z_2} \frac{\partial \bar{\theta}_m}{\partial \bar{z}_2} \\ \vdots & \vdots & \ddots & \vdots \\ \sigma_{\theta_1} \frac{\partial \bar{z}_n}{\partial \theta_1} & \sigma_{\theta_2} \frac{\partial \bar{z}_n}{\partial \theta_2} & \dots & \sigma_{\theta_m} \frac{\partial \bar{z}_n}{\partial \theta_m} \\ \sigma_{z_n} \frac{\partial \bar{\theta}_1}{\partial \bar{z}_n} & \sigma_{z_n} \frac{\partial \bar{\theta}_2}{\partial \bar{z}_n} & \dots & \sigma_{z_n} \frac{\partial \bar{\theta}_m}{\partial \bar{z}_n} \end{bmatrix} \begin{pmatrix} \left(\frac{\theta_1 - \bar{\theta}_1}{\sigma_{\theta_1}} \right) \\ \left(\frac{\theta_2 - \bar{\theta}_2}{\sigma_{\theta_2}} \right) \\ \vdots \\ \left(\frac{\theta_m - \bar{\theta}_m}{\sigma_{\theta_m}} \right) \end{pmatrix} + \tilde{\epsilon} \quad (7)$$

where the subscript j is omitted for reasons of simplicity, although it should be understood that for parameter selection purposes $j=0$ to indicate an initial parameter estimate.

If the chosen parameters are independent, then the covariance matrix is given by the identity matrix,

$$\text{Cov} \left(\frac{\theta_i - \bar{\theta}_i}{\sigma_{\theta_i}}, \frac{\theta_\ell - \bar{\theta}_\ell}{\sigma_{\theta_\ell}} \right) = \mathbf{I} \quad (8)$$

Assuming the error $\tilde{\mathbf{e}}$ in equation (7) to be independent of the parameters, then the output covariance matrix may be expressed as,

$$\text{Cov}\left(\frac{z_p - \bar{z}_p}{\sigma_{z_p}}, \frac{z_q - \bar{z}_q}{\sigma_{z_q}}\right) = \tilde{\mathbf{S}}\tilde{\mathbf{S}}^T + \text{Cov}(\tilde{\mathbf{e}}, \tilde{\mathbf{e}}) \quad (9)$$

where $\tilde{\mathbf{S}}$ is the scaled matrix of sensitivities.

Equation (9) may be expanded so that,

$$\text{Cov}\left(\frac{z_p - \bar{z}_p}{\sigma_{z_p}}, \frac{z_q - \bar{z}_q}{\sigma_{z_q}}\right) = \mathbf{s}_{\theta_1}\mathbf{s}_{\theta_1}^T + \mathbf{s}_{\theta_2}\mathbf{s}_{\theta_2}^T + \dots + \mathbf{s}_{\theta_m}\mathbf{s}_{\theta_m}^T + \text{Cov}(\tilde{\mathbf{e}}, \tilde{\mathbf{e}}) \quad (10)$$

where \mathbf{s}_{θ_k} denotes the k^{th} column of the scaled sensitivity matrix $\tilde{\mathbf{S}}$. The term $\mathbf{s}_{\theta_k}\mathbf{s}_{\theta_k}^T$ on the right-hand-side of equation (10) therefore represents the contribution of the k^{th} parameter to the scaled output covariance matrix. We would like to select those parameters that make the most significant contributions.

The matrix of measured output covariances may be expressed by its singular value decomposition as,

$$\text{Cov}\left(\frac{z_p - \bar{z}_p}{\sigma_{z_p}}, \frac{z_q - \bar{z}_q}{\sigma_{z_q}}\right) = \mathbf{U}\mathbf{\Sigma}\mathbf{U}^T \quad (11)$$

From the right-hand-sides of equations (10) and (11) it is seen that the number of parameters that contribute to $\text{Cov}\left(\frac{z_p - \bar{z}_p}{\sigma_{z_p}}, \frac{z_q - \bar{z}_q}{\sigma_{z_q}}\right)$ must be equal to the number of non-zero singular values.

The range of $\text{Cov}\left(\frac{z_p - \bar{z}_p}{\sigma_{z_p}}, \frac{z_q - \bar{z}_q}{\sigma_{z_q}}\right)$ is spanned by the columns of \mathbf{U} corresponding to the non-zero singular values,

$$\text{range}\left[\text{Cov}\left(\frac{z_p - \bar{z}_p}{\sigma_{z_p}}, \frac{z_q - \bar{z}_q}{\sigma_{z_q}}\right)\right] = \text{span}(\mathbf{U}_{\Sigma \neq 0}) \quad (12)$$

The projection onto $\mathbf{U}_{\Sigma \neq 0}$ of the contribution of each parameter θ_k to $\text{Cov}\left(\frac{z_p - \bar{z}_p}{\sigma_{z_p}}, \frac{z_q - \bar{z}_q}{\sigma_{z_q}}\right)$, i.e. each term on the right-hand-side of equation (10), is then given by,

$$\mathbf{s}'_{\theta_k} = \mathbf{U}_{\Sigma \neq 0} \mathbf{U}_{\Sigma \neq 0}^T \mathbf{s}_{\theta_k} \quad (13)$$

Ideally, if a parameter θ_k makes a non-zero contribution, then \mathbf{s}'_{θ_k} must be given exactly by a linear combination of the columns of $\mathbf{U}_{\Sigma \neq 0}$, so that \mathbf{s}_{θ_k} and \mathbf{s}'_{θ_k} are identical. In practice they will be

different due to the presence of the error term $Cov(\tilde{\mathbf{x}}, \tilde{\mathbf{x}})$ in equation (10). The cosine distance may be used to assess the closeness of \mathbf{s}'_{θ_k} to \mathbf{s}_{θ_k} ,

$$1 - \cos \psi_k = 1 - \frac{|\mathbf{s}_{\theta_k}^T \mathbf{s}'_{\theta_k}|}{\|\mathbf{s}_{\theta_k}\| \|\mathbf{s}'_{\theta_k}\|} \quad (14)$$

where ψ_k denotes the angle between \mathbf{s}_{θ_k} and \mathbf{s}'_{θ_k} . The cosine distance takes a value between zero and unity and, in practice, if less than a chosen threshold,

$$1 - \cos \psi_k < \varepsilon_{\psi} \quad (15)$$

then θ_k may be deemed to be a contributing parameter.

The test for parameter selection (15) requires that $Cov\left(\frac{z_p - \bar{z}_p}{\sigma_{z_p}}, \frac{z_q - \bar{z}_q}{\sigma_{z_q}}\right)$ shall be less than full rank, so that there are columns of \mathbf{U} corresponding to small (theoretically zero) singular values. Otherwise it is not possible to recognise wrongly selected parameters. This means that there must be more outputs than parameters.

5.0 Numerical Examples – Parameter Selection

The 3 degree of freedom structure shown in Figure 1 is considered.

Case 4: Two Randomised Parameters

In each of the exercises shown in Figures 8-11 the data is produced using two randomised parameters. All six stiffness terms are tested for significance with initial mean estimates of twice the nominal values (100% errors) and standard deviations of half the mean values (50% error). The result of using both eigenvalue and eigenvector sensitivities is shown in Figures 8a-11a whereas the result of using only the eigenvalue sensitivities is shown in Figures 8b-11b.

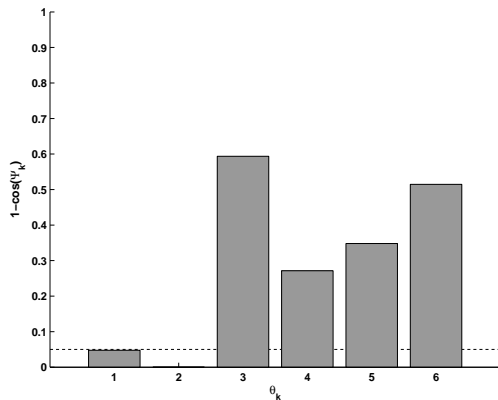

Figure 8a. Cosine distance – 3 eigenvalues, 3 eigenvectors. Randomised k_1, k_2 .

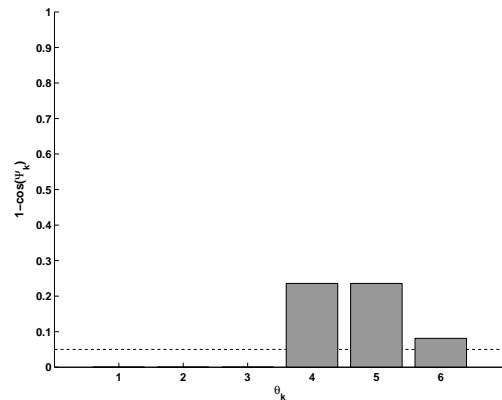

Figure 8b. Cosine distance – 3 eigenvalues only. Randomised k_1, k_2 .

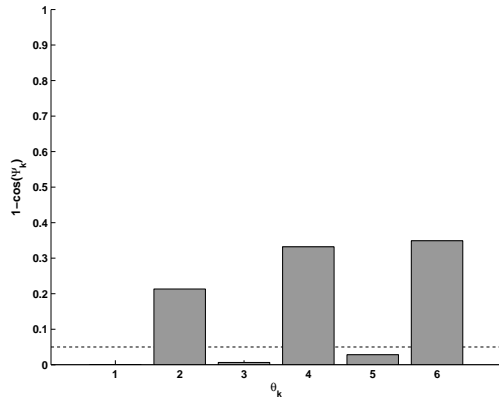

Figure 9a. Cosine distance – 3 eigenvalues, 3 eigenvectors. Randomised k_1, k_5 .

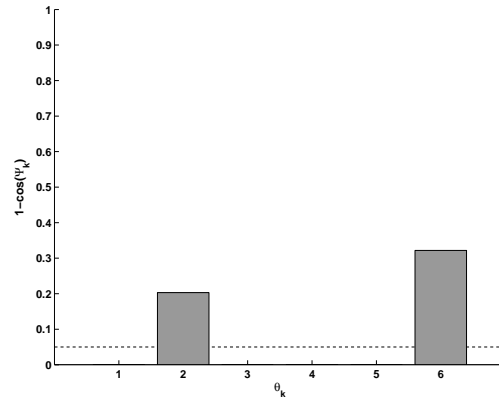

Figure 9b. Cosine distance – 3 eigenvalues only. Randomised k_1, k_5 .

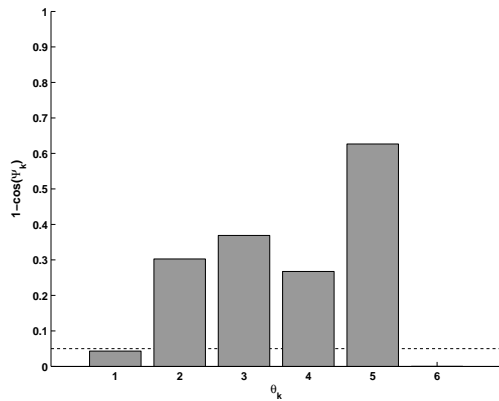

Figure 10a. Cosine distance – 3 eigenvalues, 3 eigenvectors. Randomised k_1, k_6 .

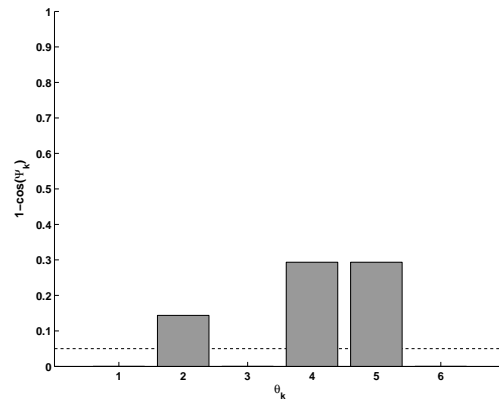

Figure 10b. Cosine distance – 3 eigenvalues only. Randomised k_1, k_6 .

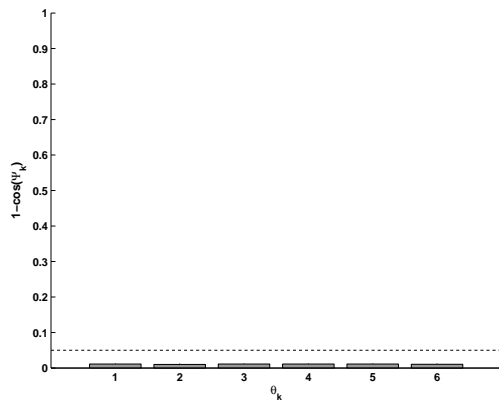

Figure 11a. Cosine distance – 3 eigenvalues, 3 eigenvectors. Randomised k_2, k_6 .

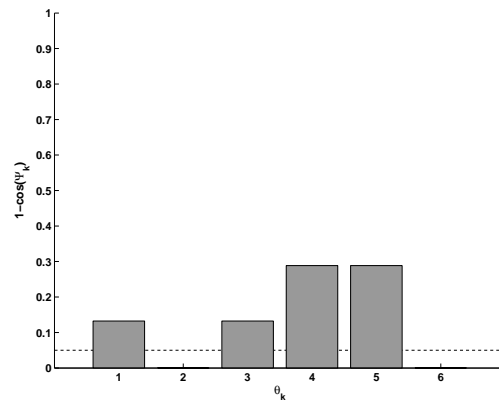

Figure 11b. Cosine distance – 3 eigenvalues only. Randomised k_2, k_6 .

It is clear that in every case the correct parameters responsible for variability in the outputs are identified. In Figures 8b, 9b and 10b not only are the correct parameters selected, but the incorrect ones are also found. This could be due in part to the symmetry of the model, where parameters k_1 and k_3 have the same effect on the eigenvalues, evident for example in Figures 8b, 9b and 10b. It is also

the case that the eigenvalue sensitivities to parameters k_4 and k_5 are the same. In the cases where these parameters are randomised, the inclusion of the eigenvectors sensitivities improves the parameter selection, allowing for the selection of only the correct parameters as shown on Figures 8a, 9a and 10a. Figure 11 shows results for randomised k_2 and k_6 . These parameters have distinct sensitivities and therefore they are correctly selected by using only the eigenvalue sensitivities as can be seen in Figure 11b.

Case 5: Three Randomised Parameters

In this case it is necessary to use both eigenvalue and eigenvector sensitivities, so that the number of outputs is greater than the number of parameters. Again, the correct parameters responsible for output variability are identified in Figures 12 and 13, although in both cases additional parameter-cosine-distances fall below the threshold marked by the dashed line. This is not a problem since it was shown in Case 2 above that stochastic updating performs well with more than the necessary number of parameters provided that the correct ones are included.

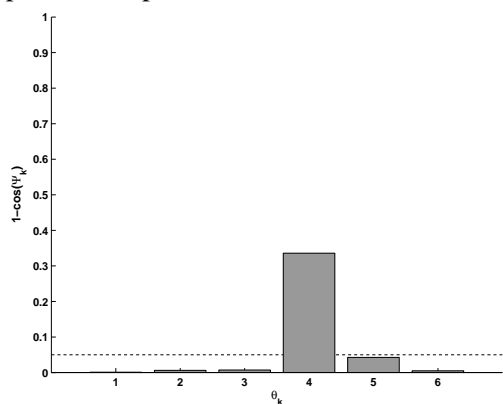

Figure 12. Cosine distance – 3 eigenvalues, 3 eigenvectors. Randomised k_1, k_2, k_5 .

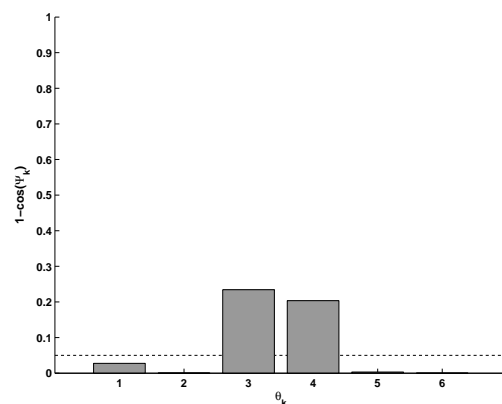

Figure 13. Cosine distance – 3 eigenvalues, 3 eigenvectors. Randomised k_1, k_2, k_6 .

6.0 Numerical Example – Pin-jointed Truss.

The pin-jointed truss shown in Figure 14 has overall dimensions 5m × 1m and is composed of 21 elements in total, each with a stiffness matrix given by,

$$\mathbf{K} = k_i \begin{bmatrix} 1 & -1 \\ -1 & 1 \end{bmatrix}; \quad i = 1, 2, \dots, 21$$

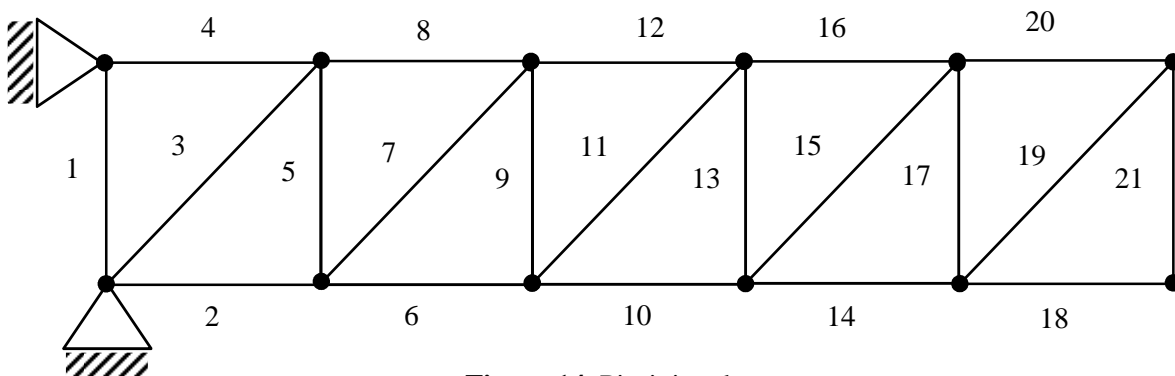

Figure 14. Pin-jointed truss.

The five diagonal bars of nominal stiffness $\frac{EA}{L} = 1.485 \times 10^8$ N/m are each randomised for updating.

The true mean value of each is equal to the nominal stiffness and the standard deviations are given by $\sigma_{k_j} = 0.135\mu_{k_j}$, $j = 3, 7, 11, 15, 19$. For the purposes of parameter selection, the initial estimates of all the mean stiffnesses, $k_i, i = 1, 2, \dots, 21$, are considered to be 70% of the reference values and the standard deviations are given by $\sigma_{k_j} = 0.27\mu_{k_3}$

Parameter selection results are shown in Figures 15-18. It is seen that the correct parameters for updating are recognised correctly in each case of different numbers of outputs.

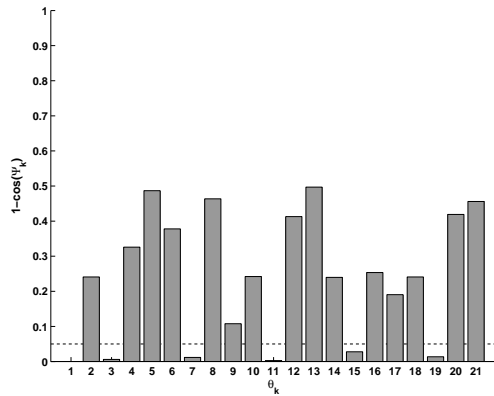

Figure 15. Cosine distance – 1st 10 eigenvalues.

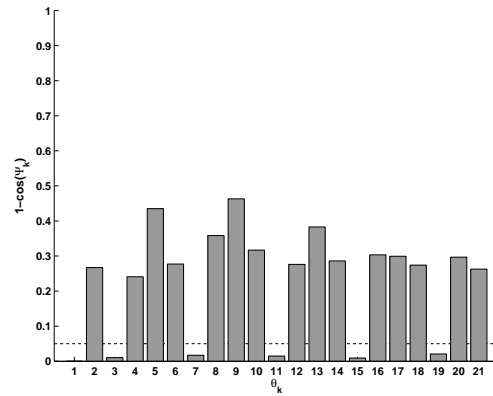

Figure 16. Cosine distance – 1st 15 eigenvalues.

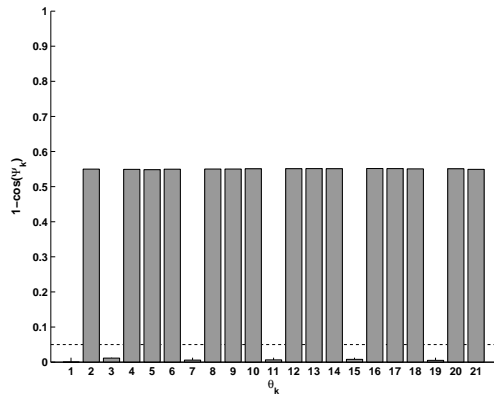

Figure 17. Cosine distance – All eigenvalues.

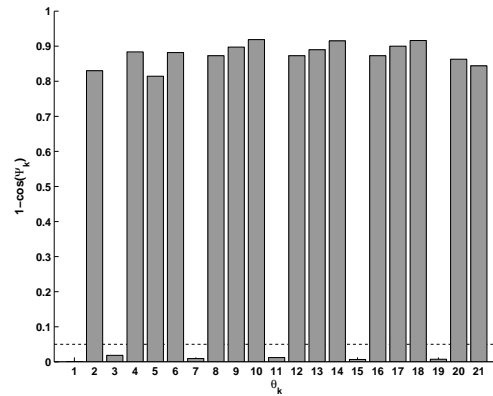

Figure 18. Cosine distance – All eigenvalues and eigenvectors.

It can be seen from the figures that the first bar element k_1 has zero cosine distance. This happens because the boundary condition prevents any extension or compression of k_1 , so that all the outputs are insensitive to it. When the constraints are removed, so the truss is in the free-free condition, the cosine distance corresponding to parameter k_1 becomes finite and exceeds the threshold as shown in Figures 19a and 19b – it is seen correctly that k_1 is not a randomised updating parameter.

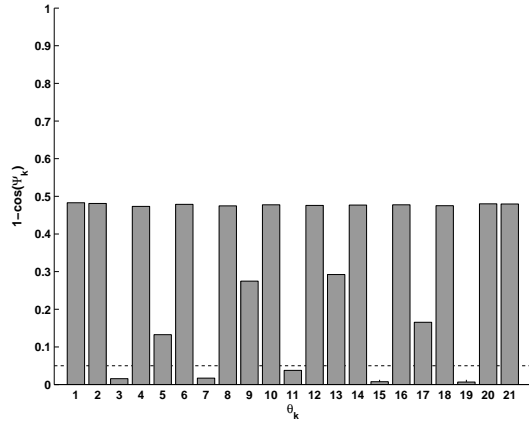

Figure 19a. Cosine distance – Free-free condition
1st 10 eigenvalues.

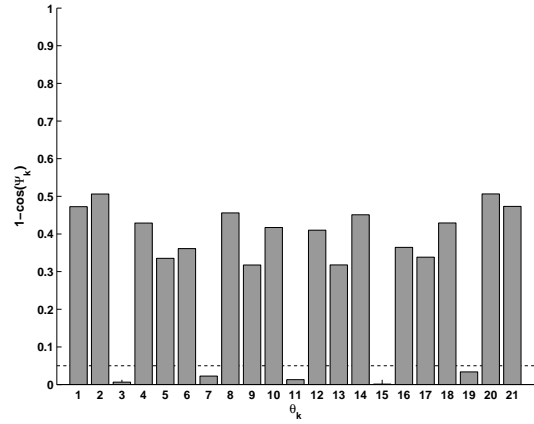

Figure 19b. Cosine distance – Free-free condition
1st 20 eigenvalues.

Having correctly identified the randomised updating parameters, it is necessary to carry out the stochastic model updating. The initial values of the updating parameters are set to:

$$k_3 = 0.70\mu_{k_3}; k_7 = 1.20\mu_{k_7}; k_{11} = 0.90\mu_{k_{11}}; k_{15} = 0.80\mu_{k_{15}}; k_{19} = 1.15\mu_{k_{19}}$$

and $\text{CoV}(k_j) = 2 \frac{\sigma_{k_j}}{\mu_{k_j}}$.

Updating results are shown in Figures 20-23. It can be observed in Figures 20 and 21 that when updating is carried out using the first 10 eigenvalues, then the exact mean values of the parameters and their covariances are closely approximated. The reconstructed output ellipses are in good but not quite perfect agreement with the measured data.

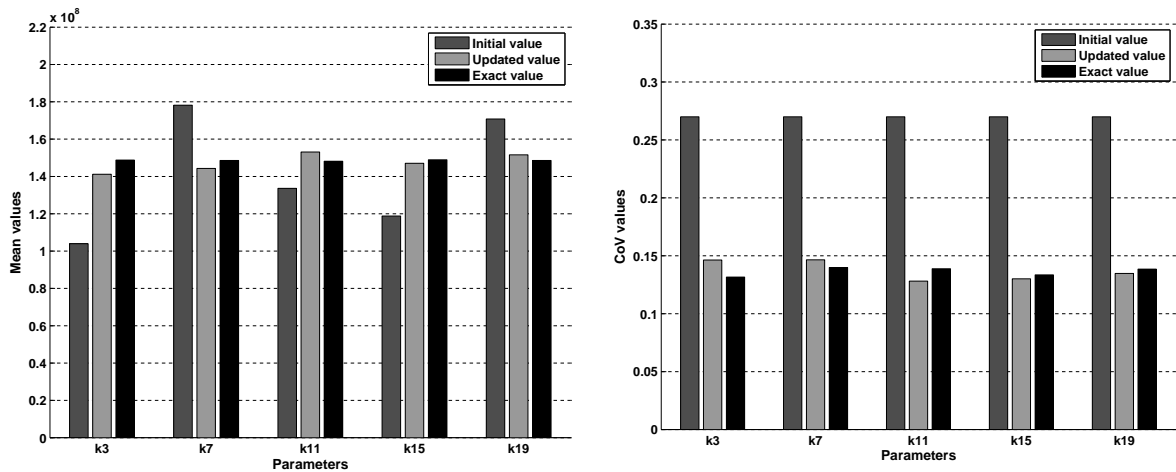

Figure 20. Identified parameters (Pin-jointed Truss - Eq. (6): using 1st 10 eigenvalues).

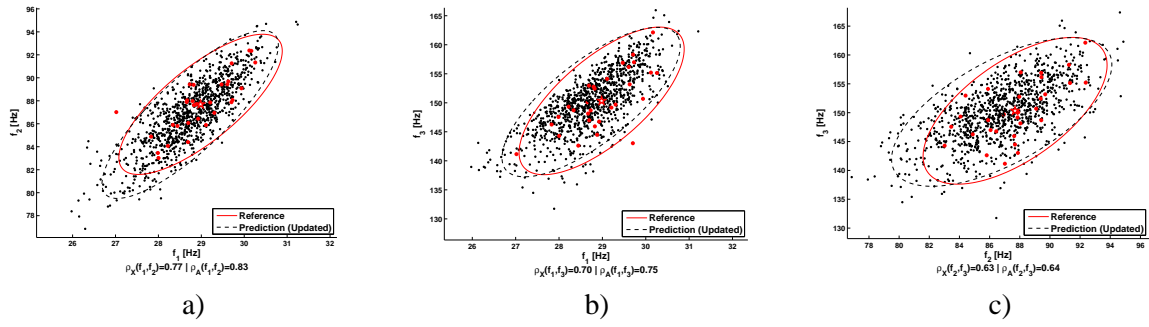

Figure 21. Frequency scatter plots (Pin-jointed Truss - Eq. (6): using 1st 10 eigenvalues).

It can be seen in Figures 22 and 23 that when all 20 eigenvalues are used in model updating the updated parameter means and covariances are in almost perfect agreement with the values used to generate the data. Also, the output covariances are reconstructed almost exactly.

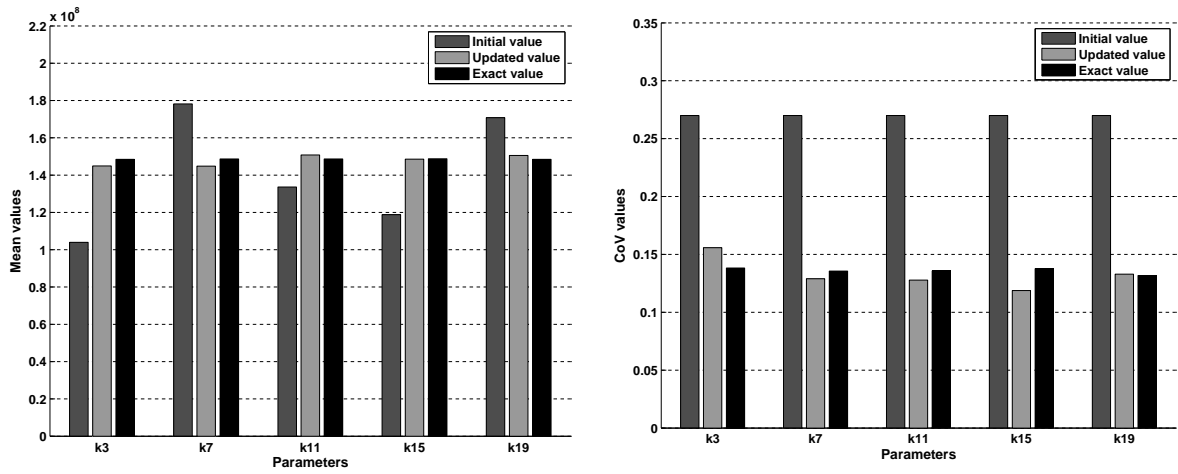

Figure 22. Identified parameters (Pin-jointed Truss - Eq. (6): using 20 eigenvalues).

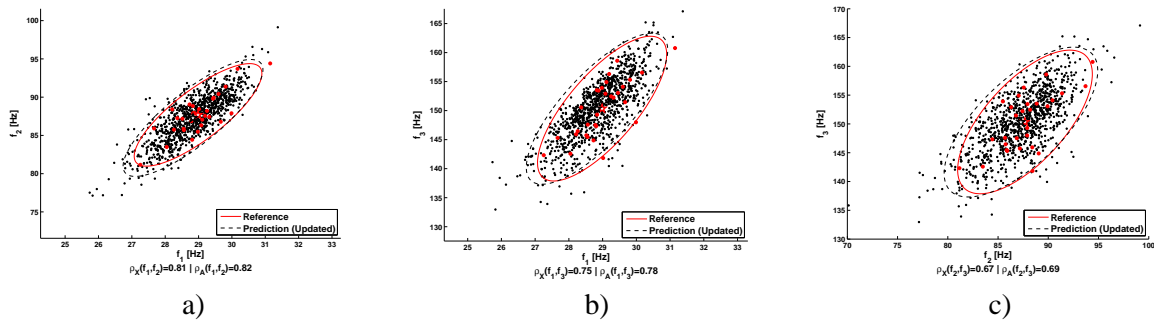

Figure 23. Frequency scatter plots (Pin-jointed Truss - Eq. (6): using 20 eigenvalues).

9.0 Conclusions.

A simple and efficient formula for updating the parameter covariance matrix is developed using only the measured output covariances and the transformation matrix obtained at the final deterministic step of updating the parameter mean values. Two previous stochastic model updating techniques are shown to be equivalent and to reduce to the same formula within the theory of small perturbations about the mean.

A simple numerical counter-example is used to demonstrate a problem: that the means may be updated correctly even when the updating parameters are wrongly chosen. This shows that parameter selection for covariance updating requires the use of techniques additional to those already used for deterministic updating.

It is shown that the measured output covariance matrix may be decomposed to reveal the contributions of each independent updating parameter. A vector is formed from a scaled column of the sensitivity matrix and the cosine distance corresponding to the angle between this vector and its projection on the space defined by the columns of the covariance matrix is used to distinguish the updating parameters from other candidate parameters that might be deemed responsible for the observed output variability.

Numerical examples are used to demonstrate the effective performance of the method in parameter selection and stochastic model updating.

Acknowledgement: The first and second authors acknowledge the support of the Portuguese Foundation for Science and Technology, FCT, under project PEst/OE/EME/LA0022/2011 and PhD grant SFRH/BD/44696/2008. The research described in this paper was partly carried out during an academic visit by the first author to the University of Liverpool.

Appendix 1:

Haddad Khodaparast et al. [16] gave the following expression for updating the parameter covariance matrix,

$$\begin{aligned} Cov(\Delta\theta_{j+1}, \Delta\theta_{j+1}) = & Cov(\Delta\theta_j, \Delta\theta_j) - Cov(\Delta\theta_j, \Delta\mathbf{z}_j) \bar{\mathbf{T}}_j^T - \bar{\mathbf{T}}_j Cov(\Delta\mathbf{z}_j, \Delta\theta_j) \\ & + \bar{\mathbf{T}}_j Cov(\Delta\mathbf{z}_j, \Delta\mathbf{z}_j) \bar{\mathbf{T}}_j^T + \bar{\mathbf{T}}_j Cov(\Delta\mathbf{z}^e, \Delta\mathbf{z}^e) \bar{\mathbf{T}}_j^T \end{aligned} \quad (16)$$

The covariances $Cov(\Delta\mathbf{z}^e, \Delta\mathbf{z}^e)$, $Cov(\Delta\mathbf{z}_j, \Delta\mathbf{z}_j)$ and $Cov(\Delta\theta_j, \Delta\mathbf{z}_j)$ are readily available from the data and from forward propagation using the distribution with mean $\bar{\theta}_j$ and $Cov(\Delta\theta_j, \Delta\theta_j)$.

Equation (16) may be simplified by further application of the small-perturbation assumption expressed as,

$$\Delta\theta_j = \bar{\mathbf{T}}_j (\mathbf{z}_j - \bar{\mathbf{z}}) = \bar{\mathbf{T}}_j \Delta\mathbf{z}_j \quad (17)$$

so that,

$$Cov(\Delta\theta_j, \Delta\mathbf{z}_j) \bar{\mathbf{T}}_j^T = \bar{\mathbf{T}}_j Cov(\Delta\mathbf{z}_j, \Delta\mathbf{z}_j) \bar{\mathbf{T}}_j^T \quad (18)$$

$$\bar{\mathbf{T}}_j \text{Cov}(\Delta \mathbf{z}_j, \Delta \boldsymbol{\theta}_j) = \bar{\mathbf{T}}_j \text{Cov}(\Delta \mathbf{z}_j, \Delta \mathbf{z}_j) \bar{\mathbf{T}}_j^T \quad (19)$$

Substitution of equations (18) and (19) into (16) leads immediately to,

$$\text{Cov}(\Delta \boldsymbol{\theta}_{j+1}, \Delta \boldsymbol{\theta}_{j+1}) = \text{Cov}(\Delta \boldsymbol{\theta}_j, \Delta \boldsymbol{\theta}_j) + \bar{\mathbf{T}}_j \text{Cov}(\Delta \mathbf{z}^e, \Delta \mathbf{z}^e) \bar{\mathbf{T}}_j^T - \bar{\mathbf{T}}_j \text{Cov}(\Delta \mathbf{z}_j, \Delta \mathbf{z}_j) \bar{\mathbf{T}}_j^T \quad (20)$$

which is identical to equation (24) given by Govers and Link [17] and implemented by forward propagation of $\Delta \boldsymbol{\theta}_j$ using a multivariate normal distribution.

Further application of (17) in the third right-hand-side term of (20) shows that,

$$\bar{\mathbf{T}}_j \text{Cov}(\Delta \mathbf{z}_j, \Delta \mathbf{z}_j) \bar{\mathbf{T}}_j^T = \text{Cov}(\Delta \boldsymbol{\theta}_j, \Delta \boldsymbol{\theta}_j) \quad (21)$$

finally resulting in

$$\text{Cov}(\Delta \boldsymbol{\theta}_{j+1}, \Delta \boldsymbol{\theta}_{j+1}) = \bar{\mathbf{T}}_j \text{Cov}(\Delta \mathbf{z}^e, \Delta \mathbf{z}^e) \bar{\mathbf{T}}_j^T \quad (22)$$

which is identical to equation (6).

References

1. J.D. Collins, G.C. Hart, T.K. Hasselman and B. Kennedy, Statistical identification of structures, *AIAA Journal*, 12(2), 1974, 185-190.
2. J.E. Mottershead and M.I. Friswell, Model updating in structural dynamics: a survey, *Journal of Sound and Vibration*, 167(2), 1993, 347-375.
3. M.I. Friswell and J.E. Mottershead, *Finite Element Model Updating in Structural Dynamics*, Kluwer Academic Publishers, Dordrecht, 1995.
4. J.E. Mottershead, M. Link and M.I. Friswell, The sensitivity method in finite element model updating: a tutorial, *Mechanical Systems and Signal Processing*, 25(7), 2011, 2275–2296.
5. E. Jacquelin, S. Adhikari and M.I. Friswell, A second-moment approach for direct probabilistic model updating in structural dynamics, *Mechanical Systems and Signal Processing*, 29, 2012, 262-283.
6. S. Adhikari and M.I. Friswell, Distributed parameter model updating using the Karhunen-Loève expansion, *Mechanical Systems and Signal Processing*, 24, 2010, 326-339.
7. B. Goller, H.J. Pradlwarter and G.I. Schuëller, Robust model updating with insufficient data, *Computer Methods in Applied Mechanical Engineering*, 198, 2009, 3096-3104.
8. L. Mthembu, T. Marwala, M.I. Friswell and S. Adhikari, Model selection in finite element model updating using the Bayesian evidence statistic, *Mechanical Systems and Signal Processing*, 25, 2011, 2399-2412.
9. J.L. Beck and L. Katafygiotis, Updating models and their uncertainties. I: Bayesian statistical framework, *Journal of Engineering Mechanics*, 124(4), 1998, 445-461.
10. L. Katafygiotis and J.L. Beck, Updating models and their uncertainties. II: model identifiability, *Journal of Engineering Mechanics*, 124(4), 1998, 463-467.
11. B. Goller, M. Broggi, A. Calvi and G.I. Schuëller, A stochastic model updating technique for complex aerospace structures, *Finite Elements in Analysis and Design*, 47, 2011, 739-752.
12. E.L. Zhang, P. Feissel and J. Antoni, A comprehensive Bayesian approach for model updating and quantification of modelling errors, *Probabilistic Engineering Mechanics*, 26, 2011, 550-560.

13. C. Mares, J.E. Mottershead and M.I. Friswell, Stochastic model updating: part 1- theory and simulated examples, *Mechanical Systems and Signal Processing*, 20(7), 2006, 1674-1695.
14. J.E. Mottershead, C. Mares, S. James and M.I. Friswell, Stochastic model updating: part 2- application to a set of physical structures, *Mechanical Systems and Signal Processing*, 20(8), 2006, 2171-2185.
15. Hua X.G, Ni Y.Q, Chen Z.Q, Ko J.M. An improved perturbation method for stochastic finite element model updating. *International Journal for Numerical Methods in Engineering*, 73, 2008, 1845-1864.
16. H. Haddad Khodaparast, J.E. Mottershead and M.I. Friswell, Perturbation methods for the estimation of parameter variability in stochastic model updating, *Mechanical Systems and Signal Processing*, 22(8), 2008, 1751-1773.
17. Y. Govers and M. Link, Stochastic model updating - covariance matrix adjustment from uncertain experimental modal data. *Mechanical Systems and Signal Processing*, 24(3):696–706, 2010.
18. H. Haddad Khodaparast, J.E. Mottershead and K.J. Badcock, Interval model updating with irreducible uncertainty using the Kriging predictor, *Mechanical Systems and Signal Processing*, 25(4), 2011, 1204-1226.
19. Y. Govers and M. Link, Using stochastic experimental modal data for identifying stochastic finite element parameters of the AIRMOD benchmark structure, *Proceedings of the International Conference on Noise and Vibration Engineering, USD2012*, Leuven, Belgium, 2012, 4697-4715.
20. Y. Govers, H. Haddad Khodaparast, M. Link and J.E. Mottershead, A comparison of two stochastic model updating methods using the DLR AIRMOD test structure, *Mechanical Systems and Signal Processing*, 52-53, 2015, 105-114.
21. S-E Fang and R. Perera, Damage identification by response surface based model updating using D-optimal design, *Mechanical Systems and Signal Processing*, 25(2), 2011, 717-733.
22. S-E. Fang, W-X. Ren and R. Perera, A stochastic model updating method for parameter variability quantification based on response surface models and Monte-Carlo simulation, *Mechanical Systems and Signal Processing*, 33, 2012, 83-96.