

Flows Between Aharony and Giveon-Kutasov Dualities in 3d Field Theories Derived from Type IIB String Theories

Thesis submitted in accordance with the requirements of
the University of Liverpool for the degree of Doctor in Philosophy

by
Siraj Khan

December 20, 2015



Abstract

Bosonic string theory and superstring theory are briefly overviewed. Three dimensional field theories are similarly discussed, with a focus on effective $N = 2$ supersymmetric theories. It is shown how to induced contributions to the Chern-Simons level of the low energy theory, by integrating out massive matter. Such effective field theories are then shown to arise from type IIB brane configurations based on the Hanany-Witten brane configuration. Strong-weak dualities are overviewed, leading to a discussion of the three dimensional strong-weak dualities: Aharony duality for theories with zero Chern-Simons level, and Giveon-Kutasov duality for theories with non-zero Chern-Simons level. In the results section, brane configurations corresponding to three-dimensional $N = 2$ $U(N_c)$ field theories with various numbers of flavour of massive matter are investigated. The resulting low energy field theories are explained, and the flows between Aharony and Giveon-Kutasov dualities are catalogued. Three dimensional $N = 2$ effective field theories obtained through the inclusion of massive adjoint matter are also examined, with the flows between Aharony and Giveon-Kutasov dualities, again, catalogued. Finally, the significance of the results and the possibilities for future research, are discussed.

Declaration

I hereby declare that all work described in this thesis is the result of my own research unless reference to others is given. None of this material has previously been submitted to this or any other university. All work was carried out in the Theoretical Physics Division of the Department of Mathematical Sciences, University of Liverpool, UK, during the period of October 2011 until April 2015.

Dedication

This work is dedicated to my parents Esin and Wahid, my aunt and uncle Dervişe and Feridun, my uncle Jeff, my sister Nevin, and my girlfriend Lizzi. Love the lot of you.

Acknowledgements

Many thanks to Radu Tatar for supporting and guiding me throughout my PhD, to Alon Faraggi for giving me the opportunity to undertake this PhD, to Paul Dempster and Thomas Mohaupt for the many times they helped me when I was stuck or confused, to John Gracey for regularly checking up on me, and to those who took the time to proof read this work (Panos Athanasopoulos, Paul Dempster, Dave Errington and my parents).

Thanks to Amihay Hanany for taking the time to explain to me how the displacement of D5-branes in a (p, q) -web, relative to a stack of D3-branes, gives rise to specific mass terms through contributions to the Fayet-Iliopoulos terms.

Publications List

This thesis contains material that has appeared in the following publications:

S. Khan and R. Tatar. Flows between Dualities for 3d Chern-Simons Theories. *Phys. Rev. D* 88, 066011 (2013).

Contents

I	Introduction	12
II	Background	16
1	The Bosonic String	17
1.1	The Nambu-Goto Action	18
1.1.1	The Canonical Momentum Densities of the String	19
1.1.2	The Equations of Motion of the Nambu-Goto Action	20
1.2	The Polyakov Action	21
1.2.1	The Equations of Motion from the Polyakov Action	21
1.3	The Polyakov Action in Conformal Gauge	22
1.3.1	The Equations of Motion from the Polyakov Action in Conformal Gauge	23
1.3.2	Momentum Densities from the Polyakov Action in Conformal Gauge	23
1.4	The Canonical Commutation Relations	23
1.5	Solutions to the Wave Equation	24
1.5.1	Open String	24
1.5.2	Closed String	25
1.6	The Energy-Momentum Tensor	26
1.6.1	The Conservation of the Energy-Momentum Tensor	26
1.6.2	The Vanishing of the Energy-Momentum Tensor	27
1.6.3	The Vanishing of the Trace of the Energy-Momentum Tensor	27
1.6.4	The Energy-Momentum Tensor in Lightcone Coordinates	28
1.6.5	Energy-Momentum Tensor Mode Expansions	28
1.7	The Classical Mass-shell Conditions	29
1.7.1	The Classical Open String Mass-Shell Condition	29
1.7.2	The Classical Closed String Mass-Shell Condition	31
1.8	Canonical Quantisation	32
1.8.1	The α_n Commutation Relations	32
1.8.2	The Redefinition of L_0	32
1.8.3	The Virasoro Algebra	33
1.9	Lightcone Gauge Quantisation	33
1.10	The Quantum Mass-Shell Condition	34
1.10.1	The Quantum Open String Mass-Shell Condition	34
1.10.2	The Quantum Closed String Mass-Shell Condition	36
1.11	The Critical Dimension $D = 26$ and the Normal Ordering Constant $a = 1$	36
1.12	The Conformal Anomaly	37

1.13	The Open String Spectrum	37
1.14	The Closed String Spectrum	39
2	The Supersymmetric String	42
2.1	The Locally Supersymmetric (Supergravity) String Action	42
2.2	The RNS Superstring Action	44
2.2.1	The RNS String Action from the Locally Supersymmetric World-sheet Action	44
2.2.2	The RNS Action as the Supersymmetric Generalisation of the Polyakov Action	46
2.2.3	The RNS Action in Lightcone Coordinates	46
2.2.4	Supersymmetry of the RNS Action	47
2.3	The Energy-Momentum Tensor of the RNS string	47
2.4	The Supercurrent of the RNS String	48
2.5	Solutions to the Wave Equation	49
2.5.1	Open String	49
2.5.2	Closed String	51
2.6	Canonical Quantisation	52
2.6.1	The Super-Virasoro Generators of the Open String	53
2.6.2	The Super-Virasoro Algebras of the Open String	54
2.7	The Quantum Mass-Shell Conditions	55
2.7.1	The Quantum Open String Mass-Shell Condition	55
2.7.2	The Quantum Closed String Mass-Shell Condition	56
2.8	The Open String Spectrum	57
2.9	The Closed String Spectrum	59
3	Branes in Type IIA and Type IIB String Theories	62
3.1	(1 + 3)d Maxwell Theory	62
3.2	Gauge Fields and Charges of Branes	63
3.3	The IIA Theory	64
3.3.1	The R-R Sector of the IIA Theory	64
3.3.2	The NS-NS Sector of the IIA Theory	66
3.4	The IIB Theory	66
3.4.1	The R-R Sector of the IIB Theory	66
3.4.2	The NS-NS Sector of the IIB Theory	68
4	3d Effective Field Theory	69
4.1	From 3d $N = 4$ (Eight Supercharge) Field Theory to 3d $N = 2$ (Four Supercharge) Field Theory	69
4.2	3d $N = 2$ $U(1)$ Theory with One Flavour of Matter and Without Antimatter	70

4.3	3d $N = 2$ $U(1)$ Theory with One Flavour of Matter and Antimatter . . .	72
4.4	3d $N = 2$ $U(1)$ Theory with N_f Flavours of Matter and Antimatter . . .	74
4.5	3d $N = 2$ $U(N_c)$ Theory with N_f Flavours of Matter and Antimatter . . .	76
4.6	Axial and Vector Masses	79
4.7	3d $N = 2$ with Ajoint Matter	80
5	Induced Chern-Simons Level from Integrating Out Massive Matter	82
5.1	Inducing Abelian Chern-Simons Terms	82
5.2	Inducing Non-abelian Chern-Simons Terms	90
5.3	Fractional Chern-Simons Level	92
6	3d Effective Field Theories from Branes	93
6.1	Strings on Dp -branes	93
6.2	Flavour Branes	96
6.3	A 3d Effective Field Theory from String Theory	98
6.3.1	An Infinite D3-brane	98
6.3.2	A D3-brane Between two NS5-branes	98
6.3.3	A D3-brane Between two D5-branes	101
6.3.4	A D3-brane between an NS5-brane and a D5-brane	103
6.3.5	A D3-brane between two NS5-branes and Intersected by a D5-Brane	104
6.3.6	Rotating the Left Hand NS5-brane	106
6.3.7	Introducing Massive matter by Introducing a D3-brane D5-brane Separation - The Naive Approach	108
6.3.8	Brane Deformations and the (p, q) -web	110
6.3.9	A D3-brane between the (p, q) -brane and the NS5-brane	113
7	Strong-Weak Dualities in 4d and 3d Field Theories	117
7.1	Electromagnetic Duality	117
7.1.1	Classical EM Duality	117
7.1.2	The Quantum Electromagnetic Duality as a Strong-Weak Duality	118
7.1.3	Dirac Monopole (Dirac String)	119
7.2	Montonen-Olive Duality	119
7.2.1	The Georgi-Glashow Theory	120
7.2.2	The $N = 2$ super-Yang-Mills Theory	121
7.2.3	The $N = 4$ super-Yang-Mills Theory	124
7.3	Seiberg Duality	125
7.3.1	S-Duality in the Conformal Window	125
7.4	Aharony Duality	131
7.4.1	Aharony Duality with Adjoint Matter	133
7.5	Giveon-Kutasov Duality	134
7.5.1	Giveon-Kutasov Duality with Adjoint Matter	135

III Results **137**

8 Theories with Massive Fundamental and Antifundamental Matter **138**

8.1	One Displaced Flavour Brane	138
8.1.1	No Displaced D3-branes	138
8.1.2	One D3-brane Displaced Upwards	142
8.1.3	One D3-brane Displaced Downwards	144
8.1.4	Two D3-branes Displaced Upwards	146
8.1.5	Two D3-branes Displaced Downwards	147
8.1.6	One D3-brane Displaced Upwards and One D3-brane Displaced Downwards	149
8.2	Two Displaced Flavour Branes	152
8.2.1	No Displaced D3-branes	152
8.2.2	One D3-brane Displaced Upwards	155
8.2.3	One D3-brane Displaced Downwards	157
8.2.4	Two D3-branes Displaced Upwards	159
8.2.5	Two D3-branes Displaced Downwards	161
8.2.6	One D3-brane Displaced Upwards and One D3-brane Displaced Downwards	163
8.2.7	Two D3-branes Displaced Upwards and One D3-brane Displaced Downwards	165
8.2.8	Two D3-branes Displaced Downwards and One D3-brane Dis- placed Upwards	167
8.2.9	Two D3-branes Displaced Upwards and Two D3-branes Displaced Downwards	169
8.3	Two Displaced Flavour Branes, Displaced by Different Amounts	172
8.3.1	No Displaced D3-branes	172
8.3.2	One D3-brane Dislaced Upwards to $x_3 = m_1$	173
8.3.3	One D3-brane Displaced Upwards to $x_3 = m_2$	175
8.3.4	One D3-brane Displaced Downwards to $x_3 = -m_2$	177
8.3.5	One D3-brane Displaced Downwards to $x_3 = -m_1$	179
8.3.6	One D3-brane Displaced Upwards to $x_3 = m_1$ and One D3-brane Displaced Upwards to $x_3 = m_2$	181
8.3.7	One D3-brane Displaced Downwards to $x_3 = -m_1$ and One D3- brane Displaced Downwards to $x_3 = -m_2$	184
8.3.8	One D3-brane Displaced Upwards to $x_3 = m_2$ and One D3-brane Displaced Downwards to $x_3 = -m_2$	186
8.3.9	One D3-brane Displaced Upwards to $x_3 = m_1$ and one D3-brane Displaced Downwards to $x_3 = -m_1$	188
8.3.10	One D3-brane Displaced Upwards to $x_3 = m_1$ and One D3-brane Displaced Downwards to $x_3 = -m_2$	191

8.3.11	One D3-brane Displaced Upwards to $x_3 = m_2$ and One D3-brane Displaced Downwards to $x_3 = -m_1$	193
9	Theories with Adjoint Matter	196
9.1	One Massive Flavour	197
9.1.1	All σ Equal Zero	198
9.1.2	Some σ Components are Positive	200
9.1.3	Some σ Components are Negative	202
9.1.4	Some σ_k^j Components are Positive and Some σ_k^j Components are Negative	204
9.2	Generalisations	208
IV	Discussion	209
V	Appendices	211
A	Lightcone Gauge	212
B	Three Dimensional $N = 2$ Superfield Conventions	213
C	Chern-Simons Field Theory	216
C.1	Integrating Over Momentum for the Induced Abelian Chern-Simons Term	216
C.2	Level Quantisation in Non-abelian Chern-Simons Gauge Theories	218
D	Angle of the (p, q)-brane and Preservation of Supersymmetry	220

Part I

Introduction

Despite being incredibly effective at describing many experimental results to a very high degree of accuracy, it has long been known that the standard model of particle physics leaves many mysteries unsolved ¹. One of the most significant (if not the most significant) unanswered question concerns how to obtain a quantum field theory description of gravity. Einstein's general relativity seems at odds with quantum field theory. For example, gravitons lead to ultraviolet divergences at two loops or higher. Another mystery is the matter-antimatter asymmetry of the universe. The standard model also fails to explain numerous physical parameters through theoretical means. Such parameters are observed experimentally, and inserted into equations with no further explanation. These mysteries lead to the conclusion that the standard model is incomplete.

Consequently, theoretical physicists are faced with the daunting challenge of formulating a theory that recreates all those experimental results the standard model succeeds in describing, whilst also explaining those mysteries the standard model fails to resolve. One famous theory that attempts to succeed the standard model is string theory. String theory has an number of features that contribute to its elegance [1]: String theory is a grand unified theory; all particles and their associated forces emerge from the string dynamics. String theory also provides a successful quantum theory of gravity. It is possible to show that the ultraviolet divergences that ail quantum field theories when gravitons are added do not occur in the loop diagrams of string theory. String theory necessitates the existence of more than four spacetime dimensions. Specifically, superstring theory predicts ten spacetime dimensions. Since only four of these are experimentally observable, the remainder are theorised to be compactified, either geometrically or non-geometrically. [1] The fact that string theory predicts the number of dimensions it inhabits is one of its intriguing features. This text will be primarily interested in those string theories that also incorporate Dp -branes and NS5-branes. Eventually, specific brane configurations of type IIB string theory will be considered, together with the low energy three dimensional $N = 2$ field theories they predict.

Three dimensional (one temporal, and two spatial dimensional) theories need little justification for study. Since spacetime is observed to be four dimensional at terrestrial energies, it is possible to consider 'planar' systems within the four dimensional spacetime, where one spatial dimension is sufficiently small to preclude excitations in that direction. For example an extremely thin sheet of material behaves as a three dimensional spacetime at sufficiently low energies. Unsurprisingly, three dimensional field theory is especially useful in the study of condensed matter systems. It therefore seems pertinent to see how such three dimensional field theories might arise as the low energy limits of string theory.

¹Although, the relatively recent discovery of the Higgs boson only bolsters admiration of the standard model!

Strong-weak dualities in three dimensional $N = 2$ field theories are of central importance to this text. One of the greatest obstacles faced by field theories is that of their strongly coupled, non-perturbative regimes. Since the methods of perturbation theory cannot be employed, such regimes are notoriously difficult to investigate. An interesting new method for investigating the strongly coupled regimes comes in the form of strong-weak duality. Certain classes of theory have been discovered whose strongly coupled regime is physically equivalent to the weakly coupled regime of another ‘dual’ theory. The theories give rise to the same observable phenomena. Importantly the two theories are also related by a ‘duality’ transformation. Such theories are interesting as the behaviour of the strongly coupled regime of one theory can be ascertained by perturbatively investigating the weakly coupled regime of its dual, and then making a duality transformation. Specifically, for effective three dimensional $N = 2$ theories with zero Chern-Simons level, Aharony duality was theorised [2], and for effective three dimensional $N = 2$ theories with non-zero Chern-Simons level, Giveon-Kutasov duality was theorised [3]. Such dualities only hold in the infrared regime. The Chern-Simons level of a theory can be altered by integrating out massive matter. Therefore, by including different flavours of massive matter in the ultraviolet regime, the type of duality exhibited at low energies can be altered.

The above concepts are combined together in this text. Type IIB string theories will be considered, and specific brane configurations will be discussed. The three dimensional $N = 2$ effective field theories that arise from such configurations are then investigated. Different massive matter contents of the high energy theories are considered, and their effects on the type of low energy dualities that arise are noted. Theories contained massive adjoint matter are also considered, with a similar discussion of the low energy dualities. In section 1 bosonic string theory is introduced. Bosonic string theory, as the name suggests, only gives rise to bosonic degrees of freedom. Despite the fact that this makes it phenomenologically unviable (observable physics demands the existence of fermions), many of the methods used for the bosonic string are useful in superstring theory. Furthermore many of the equations derived in bosonic string theory are used in the fermionic string theory (e.g. the expressions of the bosonic Virasoro generators). In section 2 superstring theory is described. The inclusion of supersymmetry gives rise to fermions as well as bosons. It is from these superstrings that the realistic field theories are obtained. The differences between type IIA and IIB string theories are also explained. In section 3 the types of branes that are theorised to exist in type IIA and IIB string theories are explained. The branes of both theories are discussed for completeness, although only type IIB theory (and its associated branes) are used in the results section. In section 4 a brief overview of the relevant concepts of three dimensional field theory are discussed. Many of the equations and action terms introduced in this section will be referred to

in the results section. In section 5 it is explained how integrating out massive matter results in contributions to the bare Chern-Simon level in the three dimensional effective field theory. In section 6 it is explained how three dimensional $N = 2$ effective field theories are obtained from type IIB brane configurations. Therefore, this section provides a direct correspondence between the string theory and field theory of interest. In section 7 a brief pedagogical introduction to strong-weak dualities is provided. The section concludes with explanations of Aharony and Giveon-Kutasov dualities. In part III the results of [4] are presented: In section 8 theories without adjoint matter (only fundamental and antifundamental matter) are discussed. Various brane configurations are presented corresponding to various numbers of massive flavours. The resulting three dimensional $N = 2$ effective field theories, and their dualities, are explained. In section 9 three dimensional $N = 2$ effective theories, obtained by integrating out massive adjoint matter, are discussed. Again, the resulting dualities are catalogued. Finally, in part IV the results are discussed, and future possibilities for research are explored.

Part II

Background

1 The Bosonic String

Whilst the research presented in this text primarily concerns $(1 + 2)d$ $N = 2$ field theories derived from superstring theories, it is useful to provide an overview of bosonic string theory. Bosonic string theory provides an introduction to the concepts used in superstring theory, and many of the equations derived from the bosonic string have analogous expressions in superstring theory.

During its passage in space and time a one-dimensional extended object (a string) traces out a two-dimensional worldsheet Σ [1]. This is analogous to the worldline traced out by a point particle. Classical string theory involves a map X from a two-dimensional string worldsheet, Σ with metric $h^{\alpha\beta}$, to a target manifold \mathcal{M} , with metric $\eta^{\mu\nu}$:

$$X : \Sigma \rightarrow \mathcal{M} \tag{1.1}$$

In bosonic string theory \mathcal{M} is often taken to be a $(1 + 25)$ -dimensional spacetime, whilst in superstring theory it is often a $(1 + 9)$ -dimensional spacetime. The exact shape of the spacetime compactification can vary. Consider the example of the open string. The string worldsheet Σ is parameterised by two coordinates $\sigma^\alpha = (\sigma^0, \sigma^1) = (\tau, \sigma)$ and has a metric $h^{\alpha\beta}$ [1]:

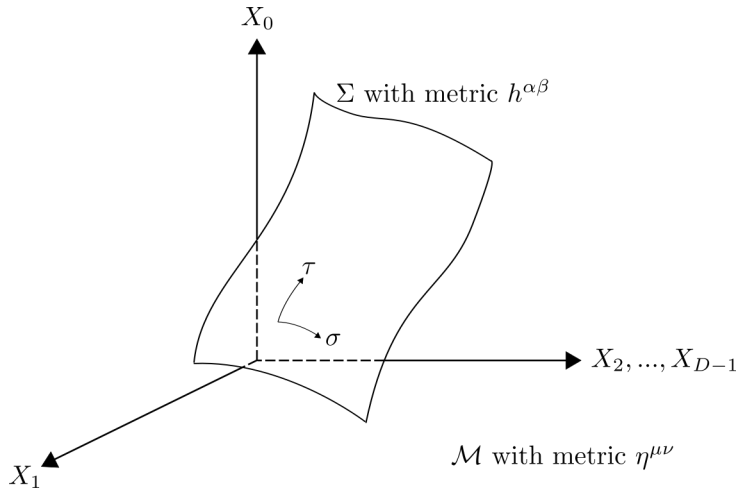

Figure 1: A worldsheet Σ in a target space \mathcal{M} .

The map X takes a worldsheet point (τ, σ) to a spacetime point $X_\mu(\tau, \sigma)$. For D -dimensional spacetime there are D coordinates $X_{0,1,\dots,D-1}(\tau, \sigma)$ which can be interpreted as D scalar fields on Σ .

1.1 The Nambu-Goto Action

In order to discuss dynamics an action must be formulated for the theory. To understand how this might be achieved, it helps to first look at the point particle as an example [5]. The worldline Σ_{point} of a point particle is parameterised by a single coordinate, τ , and a 1d metric h_{00} (note the metric only has a single component). When the worldline is embedded into D-dimensional spacetime with metric $\eta^{\mu\nu}$, the pullback is given as:

$$h_{00} = \frac{\partial X^\mu}{\partial \tau} \frac{\partial X^\nu}{\partial \tau} \eta_{\mu\nu} \quad (1.2)$$

The action for the point particle can then be written:

$$\begin{aligned} \frac{-S_{\text{point}}}{m} &= \int d\tau \sqrt{-h_{00}} \\ &= \int d\tau \sqrt{-\frac{\partial X^\mu}{\partial \tau} \frac{\partial X^\nu}{\partial \tau} \eta_{\mu\nu}} \\ &= \text{1d volume of worldline (length of trajectory)} \end{aligned} \quad (1.3)$$

Using the same formalism, the action emerging from the worldsheet traced out by a string moving through spacetime is given by [5]:

$$\frac{-S_{\text{NG}}}{T} = \text{2d volume of worldsheet (area of trajectory)} \quad (1.4)$$

Where T is the mass per unit length of the string, called the string tension. The subscript ‘NG’ is provided in anticipation of this action giving rise to the Nambu-Goto action. [1, 6] The spacetime positions $X = X(\tau, \sigma)$ are now functions of two (worldsheet) coordinates instead of one (worldline) coordinate. Therefore, instead of:

$$\frac{\partial X^\mu}{\partial \tau} \quad (1.5)$$

the worldsheet has:

$$\frac{\partial X^\mu}{\partial \sigma^\alpha} \quad (1.6)$$

The worldsheet pullback, analogous to Equation 1.2, is then written:

$$h_{\alpha\beta} = \frac{\partial X^\mu}{\partial \sigma^\alpha} \frac{\partial X^\nu}{\partial \sigma^\beta} \eta_{\mu\nu} \quad (1.7)$$

Writing equation 1.4 in the same form as equation 1.2 (with $-h = -\det(h_{\alpha\beta})$ instead of $-h_{00}$) gives [1, 6]:

$$\begin{aligned}
\frac{-S_{\text{NG}}}{T} &= \int d\tau d\sigma \sqrt{-h} \\
&= \int d\tau d\sigma \sqrt{-\det(h_{\alpha\beta})} \\
&= 2\text{d volume of worldsheet}
\end{aligned} \tag{1.8}$$

Writing equation 1.7 in matrix form gives:

$$\begin{aligned}
h_{\alpha\beta} &= \begin{pmatrix} \frac{\partial X^\mu}{\partial \sigma^0} \frac{\partial X_\mu}{\partial \sigma^0} & \frac{\partial X^\mu}{\partial \sigma^0} \frac{\partial X_\mu}{\partial \sigma^1} \\ \frac{\partial X^\mu}{\partial \sigma^1} \frac{\partial X_\mu}{\partial \sigma^0} & \frac{\partial X^\mu}{\partial \sigma^1} \frac{\partial X_\mu}{\partial \sigma^1} \end{pmatrix} \\
&= \begin{pmatrix} \frac{\partial X^\mu}{\partial \sigma} \frac{\partial X_\mu}{\partial \tau} & \frac{\partial X^\mu}{\partial \sigma} \frac{\partial X_\mu}{\partial \sigma} \\ \frac{\partial X^\mu}{\partial \tau} \frac{\partial X_\mu}{\partial \sigma} & \frac{\partial X^\mu}{\partial \tau} \frac{\partial X_\mu}{\partial \tau} \end{pmatrix} \\
&= \begin{pmatrix} \dot{X}^2 & \dot{X} \cdot X' \\ X' \cdot \dot{X} & X'^2 \end{pmatrix}
\end{aligned} \tag{1.9}$$

$$\Rightarrow \det(h_{\alpha\beta}) = \dot{X}^2 X'^2 - (\dot{X} \cdot X')^2 \tag{1.10}$$

Plugging equation 1.10 in to equation 1.8 gives:

$$\frac{-S_{\text{NG}}}{T} = \int d\tau d\sigma \sqrt{(\dot{X} \cdot X')^2 - \dot{X}^2 X'^2} \tag{1.11}$$

$$\boxed{S_{\text{NG}} = -T \int d\tau d\sigma \sqrt{(\dot{X} \cdot X')^2 - \dot{X}^2 X'^2}} \tag{1.12}$$

This is the Nambu-Goto action of the bosonic string.

1.1.1 The Canonical Momentum Densities of the String

The canonical momentum densities are defined as P_α^μ , $\alpha = 0, 1$:

$$P_0^\mu \equiv \Pi^\mu \equiv \frac{\partial \mathcal{L}}{\partial \dot{X}_\mu}, \quad P_1^\mu \equiv \frac{\partial \mathcal{L}}{\partial X'_\mu} \tag{1.13}$$

Written explicitly, these are given as:

$$P_0^\mu = \Pi^\mu = \frac{T \left((\dot{X}^\mu)(X')^2 - (\dot{X} \cdot X')(X'^\mu) \right)}{\sqrt{(\dot{X} \cdot X')^2 - \dot{X}^2 X'^2}} \quad (1.14)$$

$$P_1^\mu = \frac{T \left(\dot{X}^2 X'^\mu - (\dot{X} \cdot X')\dot{X}^\mu \right)}{\sqrt{(\dot{X} \cdot X')^2 - \dot{X}^2 X'^2}} \quad (1.15)$$

Constraints on the Canonical Momentum Densities

The constraints on the canonical momentum densities are:

$$\Pi^\mu X'_\mu = 0 \quad (1.16)$$

$$\Pi^2 + T^2(X')^2 = 0 \quad (1.17)$$

$$\mathcal{H}_{\text{can}} = \dot{X}\Pi - \mathcal{L}_{\text{NG}} = 0 \quad (1.18)$$

where \mathcal{H}_{can} is the canonical Hamiltonian.

1.1.2 The Equations of Motion of the Nambu-Goto Action

Consider variation of the spacetime position $X(\tau, \sigma)$ by a small amount $\epsilon(\tau, \sigma)$:

$$\tilde{X}(\tau, \sigma) = X(\tau, \sigma) + \epsilon(\tau, \sigma) \quad (1.19)$$

Infinitesimally, this is written:

$$\delta X = \epsilon(\tau, \sigma) \quad (1.20)$$

Setting the variation of the action to zero then gives the equations of motion:

$$\frac{\partial}{\partial \tau} P_0^\mu = 0 \quad \text{and} \quad \frac{\partial}{\partial \sigma} P_1^\mu = 0 \quad (1.21)$$

1.2 The Polyakov Action

Unfortunately the Nambu-Goto action (equation 1.12) is not easy to quantise due to the presence of the square root. Rather than attempting to quantise the Nambu-Goto action, it will prove useful to re-express it in a new form; as the Polyakov action.

The Polyakov action is given as [7]:

$$S_P = -\frac{T}{2} \int d^2\sigma \sqrt{-h} h^{\alpha\beta} \partial_\alpha X^\mu \partial_\beta X^\nu \eta_{\mu\nu} \quad (1.22)$$

where $h \equiv -\det(h_{\alpha\beta})$ and $h^{\alpha\beta}$ is defined in equation 1.7. Note that the string tension T is sometimes written as:

$$T = \frac{1}{2\pi\alpha'} = \frac{1}{2\pi l_s^2} \quad (1.23)$$

where α' is the ‘Regge slope’. This gives:

$$S_P = -\frac{1}{4\pi\alpha'} \int d^2\sigma \sqrt{-h} h^{\alpha\beta} \partial_\alpha X^\mu \partial_\beta X^\nu \eta_{\mu\nu} \quad (1.24)$$

Of course the expression for T can also be used to rewrite equation 1.12.

1.2.1 The Equations of Motion from the Polyakov Action

Variation of the Action with Respect to X^μ

Consider variation of the spacetime position $X(\tau, \sigma)$ by a small amount $\epsilon(\tau, \sigma)$:

$$\tilde{X}(\tau, \sigma) = X(\tau, \sigma) + \epsilon(\tau, \sigma) \quad (1.25)$$

Infinitesimally, this is written:

$$\delta X = \epsilon(\tau, \sigma) \quad (1.26)$$

Setting the variation of the action to zero then gives the equations of motion [8]:

$$\partial_\alpha \left(\sqrt{-h} h^{\alpha\beta} \partial_\beta X_\mu \right) = 0 \quad (1.27)$$

This is the equation of motion using the curved worldsheet metric $h_{\alpha\beta}$. Later, conformal gauge will be used and the curved worldsheet metric will be replaced by the flat one $\eta_{\alpha\beta}$. It is possible to show that [8]:

$$\partial_\alpha \left(\sqrt{h} h^{\alpha\beta} \partial_\beta X_\mu \right) = \sqrt{h} \nabla^\alpha \nabla_\alpha X_\mu = 0 \quad (1.28)$$

This gives:

$$\nabla^\alpha \nabla_\alpha X_\mu = 0 \quad (1.29)$$

where ∇_α is a covariant derivative called the ‘Levi-Civita connection’ on $(\Sigma, h_{\alpha\beta})$.

Variation with Respect to the Worldsheet Metric

Imposing invariance of the action under variation of the metric gives the equation of motion [1]:

$$\partial_\gamma X^\mu \partial_\delta X_\mu - \frac{1}{2} \partial_\alpha X^\mu \partial_\beta X_\mu h^{\alpha\beta} h_{\gamma\delta} = 0 \quad (1.30)$$

1.3 The Polyakov Action in Conformal Gauge

The Polyakov action is invariant under reparametrisation and Weyl transformation. Using reparametrisation and Weyl transformations, conformal gauge can be achieved. In this gauge the Polyakov action is given by:

$$S_P = -\frac{1}{4\pi\alpha'} \int d^2\sigma \eta^{\alpha\beta} \partial_\alpha X^\mu \partial_\beta X^\nu \eta_{\mu\nu} \quad (1.31)$$

Reparameterisation invariance corresponds to two local symmetries, since there are two coordinates that can be reparameterised independently. Weyl invariance corresponds to one more local symmetry. This gives a total of three local symmetries. It just so happens that the 2-dimensional worldsheet metric has three independent components, since it is a symmetric 2×2 matrix. The independent components are h_{00} , h_{11} and $h_{01} = h_{10}$. The upshot is that three symmetries (the two coordinate reparameterisation symmetries and Weyl symmetry) were used to fix the three independent components of $h_{\alpha\beta}$ [7, 9]:

$$h_{\alpha\beta} \rightarrow \eta_{\alpha,\beta} \quad (1.32)$$

1.3.1 The Equations of Motion from the Polyakov Action in Conformal Gauge

Variation of the Action with Respect to X^μ

Under variation with respect to X^μ , the Polyakov action in conformal gauge gives the equation of motion [1]:

$$\eta^{\alpha\beta} \partial_\alpha \partial_\beta X^\mu = 0 \quad (1.33)$$

which is a wave equation. In lightcone coordinates this becomes [1]:

$$\partial_+ \partial_- X^\mu = 0 \quad (1.34)$$

1.3.2 Momentum Densities from the Polyakov Action in Conformal Gauge

The momentum densities of the string are given by [1]:

$$\mathcal{P}_\mu^\alpha = \frac{\partial \mathcal{L}}{\partial(\partial_\alpha X^\mu)} \quad (1.35)$$

This gives the canonical momenta:

$$\mathcal{P}_\mu^0 = \frac{\partial \mathcal{L}}{\partial(\partial_0 X^\mu)} = T \partial_0 X_\mu \quad (1.36)$$

and:

$$\mathcal{P}_\mu^1 = \frac{\partial \mathcal{L}}{\partial(\partial_1 X^\mu)} = -T \partial_1 X_\mu \quad (1.37)$$

1.4 The Canonical Commutation Relations

The canonical commutation relations are given by [1, 10, 11]:

$$[X^\mu(\tau, \sigma), X^\nu(\tau, \sigma')] = [\mathcal{P}^{0\mu}(\tau, \sigma), \mathcal{P}^{0\nu}(\tau, \sigma')] = 0 \quad (1.38)$$

$$[X^\mu(\tau, \sigma), \mathcal{P}^\nu(\tau, \sigma')] = i\eta^{\mu\nu} \delta(\sigma - \sigma') \quad (1.39)$$

1.5 Solutions to the Wave Equation

It is now possible to obtain the solutions to the wave equation (equation 1.33). These solutions are needed to eventually quantise the bosonic string, and to obtain expressions for the creation and annihilation operators. Begin by writing the most general solution to the wave equation [1, 10, 11]:

$$\eta^{\alpha\beta}\partial_\alpha\partial_\beta X^\mu = 0 \quad (1.40)$$

before imposing boundary conditions.

1.5.1 Open String

Neumann and Dirichlet Boundary Conditions

An open string with worldsheet coordinates τ (ranging from $-\infty$ to ∞) and σ (ranging from 0 to π) can have either Neumann or Dirichlet boundary conditions at each end point, where the endpoints exist at $\sigma = 0$ and at $\sigma = \pi$. A string whose spacetime position is parametrised by $X^\mu(\tau, \sigma)$, has Dirichlet boundary conditions along the spatial dimensions a if [1]:

$$X^a(\tau, 0) = X^a(\tau, \pi) = 0 \quad (1.41)$$

This means that the endpoints of the string do not move in the spatial directions labelled by a . Alternatively, the string has Neumann boundary conditions along the spatial directions a if [1]:

$$\left. \frac{dX^a(\tau, \sigma)}{d\sigma} \right|_{\sigma=0} = \left. \frac{dX^a(\tau, \sigma)}{d\sigma} \right|_{\sigma=\pi} = 0 \quad (1.42)$$

In general the string has Neumann boundary conditions along the time dimension $\mu = 0$:

$$\left. \frac{dX^0(\tau, \sigma)}{d\sigma} \right|_{\sigma=0} = \left. \frac{dX^0(\tau, \sigma)}{d\sigma} \right|_{\sigma=\pi} = 0 \quad (1.43)$$

Dp-branes

Dirichlet and Neumann boundary conditions allow ‘Dp-branes’ to be defined, where the ‘D’ stands for ‘Dirichlet’ [1]. A Dp-brane is a dynamical object p -spatial-dimensional object that strings can end on. The end points of the string can move along those directions in which the Dp-brane extends, but they cannot move in the directions normal to the brane. So, for example, consider a D3-brane which

extends along x_1 , x_5 and x_6 . Strings ending on this brane have Neumann boundary conditions for X^0 , X^1 , X^5 and X^6 , and Dirichlet boundary conditions for all remaining $X(\tau, \sigma)$ components. In this text, configurations consisting of various Dp -branes will be used to formulate string theories that give rise to interesting low energy $(1+2)$ -dimensional field theories. Dp -branes are discussed further in sections 3 and 6.

Open Bosonic String with Neumann Boundary Conditions at Both Ends

If both ends of the string are free to move (i.e. They satisfy Neumann boundary conditions) the solution to the wave equation becomes [1, 10, 11]:

$$X^\mu(\tau, \sigma) = x^\mu + \sqrt{2\alpha'}\alpha_0^\mu\tau + i\sqrt{2\alpha'}\sum_{m\neq 0}\frac{\alpha_m^\mu}{m}e^{-im\tau}\cos(m\sigma) \quad (1.44)$$

where $([1])\alpha_0^\mu = \sqrt{2\alpha'}p^\mu$ and where $l_s = \sqrt{\alpha'}$. Using $\alpha' = l_s^2$ the X^μ mode expansion can be rewritten:

$$X^\mu(\tau, \sigma) = x^\mu + \sqrt{2}l_s\alpha_0^\mu\tau + i\sqrt{2}l_s\sum_{m\neq 0}\frac{\alpha_m^\mu}{m}e^{-im\tau}\cos(m\sigma) \quad (1.45)$$

Using $\alpha_0^\mu = \sqrt{2\alpha'}p^\mu = \sqrt{2}l_s p^\mu$:

$$X^\mu(\tau, \sigma) = x^\mu + 2l_s^2 p^\mu \tau + i\sqrt{2}l_s\sum_{m\neq 0}\frac{\alpha_m^\mu}{m}e^{-im\tau}\cos(m\sigma) \quad (1.46)$$

Open Bosonic String with Dirichlet Boundary Conditions at Both Ends

If both ends are fixed (i.e. they satisfy Dirichlet boundary conditions) the solution of the wave equation becomes [10]:

$$X^\mu(\tau, \sigma) = x^\mu + 2l_s^2 p^\mu \sigma - i\sqrt{2}l_s\sum_{m\neq 0}\frac{\alpha_m^\mu}{m}e^{-im\tau}\sin(m\sigma) \quad (1.47)$$

1.5.2 Closed String

Closed strings have a periodic boundary condition [1]:

$$X^\mu(\tau, \sigma) = X^\mu(\tau, \sigma + 2\pi) \quad (1.48)$$

With this condition in mind, the left and right moving X^μ modes of the closed string are given by [1, 10, 11]:

$$X_R^\mu = \frac{x_0^\mu}{2} + l_s^2 p^\mu (\tau - \sigma) + \frac{i}{\sqrt{2}} l_s \sum_{n \neq 0} \frac{\alpha_n^\mu}{n} e^{-in(\tau - \sigma)} \quad (1.49)$$

$$X_L^\mu = \frac{x_0^\mu}{2} + l_s^2 p^\mu (\tau + \sigma) + \frac{i}{\sqrt{2}} l_s \sum_{n \neq 0} \frac{\tilde{\alpha}_n^\mu}{n} e^{-in(\tau + \sigma)} \quad (1.50)$$

The left and right moving modes can be combined to give [1, 10, 11] :

$$\begin{aligned} X^\mu(\tau, \sigma) &= X_R^\mu + X_L^\mu \\ &= x_0^\mu + 2l_s^2 p^\mu \tau + \frac{i}{\sqrt{2}} l_s \sum_{n \neq 0} \frac{e^{-2in\tau}}{n} (\alpha_n^\mu e^{2in\sigma} + \tilde{\alpha}_n^\mu e^{-2in\sigma}) \end{aligned} \quad (1.51)$$

1.6 The Energy-Momentum Tensor

It can be shown that the energy-momentum tensor appears in the Noether current associated with conformal symmetry of the pre-gauge-fixed Polyakov action [12]. Specifically, it is the conserved current associated with translational symmetry, where translations are a specific type of conformal transformation. Consider a general translation:

$$\begin{aligned} \sigma^\alpha &\rightarrow \sigma^{\alpha'} = \sigma^\alpha + \delta\sigma^\alpha \\ &= \sigma^\alpha + \epsilon^\alpha \end{aligned} \quad (1.52)$$

where $\epsilon^\alpha \equiv \delta\sigma^\alpha$. It can be shown that, up to a constant, the conserved current contains a term of the form [12]:

$$T_{\alpha\beta} \equiv -\frac{1}{T} \frac{1}{\sqrt{h}} \frac{\delta S_P}{\delta h^{\alpha\beta}} \quad (1.53)$$

Which is called the energy-momentum tensor. Calculating the variation of the action with respect to $h^{\alpha\beta}$ explicitly gives the energy momentum tensor as:

$$T_{\alpha\beta} = \frac{1}{2} \partial_\alpha X^\mu \partial_\beta X_\mu - \frac{1}{4} h_{\alpha\beta} h^{\gamma\delta} \partial_\gamma X^\mu \partial_\delta X_\mu \quad (1.54)$$

1.6.1 The Conservation of the Energy-Momentum Tensor

The energy-momentum tensor is conserved [10]:

$$\nabla^\alpha T_{\alpha\beta} = 0 \quad (1.55)$$

In conformal gauge, where the metric is taken to be the flat space metric, the replacement $\nabla^\alpha \rightarrow \partial^\alpha$ is made, since the Christoffel symbols in ∇^α vanish. Therefore, on the flat worldsheet (in conformal gauge) [10]:

$$\partial^\alpha T_{\alpha\beta} = 0 \quad (1.56)$$

This result can also be achieved by demanding that current $J_\alpha = T_{\alpha\beta}\epsilon^\beta$ is conserved for constant ϵ^β [13]:

$$\begin{aligned} 0 &= \partial^\alpha J_\alpha \\ &= \partial^\alpha (T_{\alpha\beta}\epsilon^\beta) \\ &= (\partial^\alpha T_{\alpha\beta})\epsilon^\beta + T_{\alpha\beta} \left(\cancel{\partial^\alpha \epsilon^\beta} \right)^0 \end{aligned} \quad (1.57)$$

$$\Rightarrow \partial^\alpha T_{\alpha\beta} = 0$$

1.6.2 The Vanishing of the Energy-Momentum Tensor

One of the equations of motion stated above was:

$$\partial_\gamma X^\mu \partial_\delta X_\mu - \frac{1}{2} \partial_\alpha X^\mu \partial_\beta X_\mu h^{\alpha\beta} h_{\gamma\delta} = 0 \quad (1.58)$$

Which implies [7]:

$$T_{\alpha\beta} = 0 \text{ (On-Shell)} \quad (1.59)$$

Since a system is on-shell when it obeys the classical equations of motion, and since the vanishing of the energy-momentum tensor is obtained as a direct result of an equation of motion, the vanishing of the energy-momentum is only true on-shell [7].

1.6.3 The Vanishing of the Trace of the Energy-Momentum Tensor

Since the vanishing of the energy-momentum tensor has only been proven to be true on-shell, it is still worthwhile considering other properties of the tensor. For example the energy-momentum tensor has zero trace [10]:

$$\text{Tr}(T_{\alpha\beta}) = T^\alpha_\alpha = 0 \quad (1.60)$$

Since the equations of motion were not used to obtain the vanishing of the trace, it vanishes both on-shell and off-shell. It is also possible to show the vanishing of the trace of the energy-momentum tensor by demanding the invariance of the Polyakov action in conformal gauge under translations. Or it can be shown from invariance of the Polyakov action under scalings of the metric.

1.6.4 The Energy-Momentum Tensor in Lightcone Coordinates

In light-cone coordinates the energy-momentum tensor is given by [1]:

$$T_{++} = \partial_+ X^\mu \partial_+ X_\mu \quad (1.61)$$

$$T_{--} = \partial_- X^\mu \partial_- X_\mu \quad (1.62)$$

$$T_{-+} = T_{+-} = 0 \quad (1.63)$$

The energy-momentum tensor in canonical coordinates can be written in terms of these as [1]:

$$T_{00} = T_{11} = T_{++} + T_{--} \quad (1.64)$$

$$T_{01} = T_{10} = T_{++} - T_{--} \quad (1.65)$$

1.6.5 Energy-Momentum Tensor Mode Expansions

The energy-momentum tensors for the open string can be expressed in terms of their mode expansions as [1, 11]:

$$T_{++} = l_s^2 \sum_{m=-\infty}^{\infty} L_m e^{-im(\tau+\sigma)} \quad (1.66)$$

$$T_{--} = l_s^2 \sum_{m=-\infty}^{\infty} L_m e^{-im(\tau-\sigma)} \quad (1.67)$$

$$\text{where } L_m = \frac{1}{2} \sum_{n=-\infty}^{\infty} \alpha_{m-n} \cdot \alpha_n \quad (1.68)$$

The energy-momentum tensors for the closed string can be expressed in terms of their mode expansions as [1, 11]:

$$T_{++} = l_s^2 \sum_{m=-\infty}^{\infty} \tilde{L}_m e^{-im(\tau+\sigma)} \quad (1.69)$$

$$T_{--} = l_s^2 \sum_{m=-\infty}^{\infty} L_m e^{-im(\tau-\sigma)} \quad (1.70)$$

$$\text{where } \tilde{L}_m = \frac{1}{2} \sum_{n=-\infty}^{\infty} \tilde{\alpha}_{m-n} \cdot \tilde{\alpha}_n \quad (1.71)$$

$$\text{and } L_m = \frac{1}{2} \sum_{n=-\infty}^{\infty} \alpha_{m-n} \cdot \alpha_n \quad (1.72)$$

1.7 The Classical Mass-shell Conditions

Recall that, in the on-shell classical theory, the energy-momentum tensor vanishes. As a result, classically and on-shell, the Fourier modes of the energy-momentum tensor are also expected to vanish. Equations 1.64 and 1.65 show that T_{++} and T_{--} must vanish identically in order for all components of the energy-momentum tensor to vanish.

1.7.1 The Classical Open String Mass-Shell Condition

For the open string, equations 1.66 and 1.67 show that T_{++} and T_{--} vanish when [1, 10, 11]:

$$L_m = 0 \quad m \in \mathbb{Z} \quad (1.73)$$

The zero modes are then given by:

$$L_0 = 0 \quad (1.74)$$

In the classical theory, L_m and the oscillators α_n are not operators. This means that α_{-n} and α_n commute. As such L_0 can be written [1, 10, 11]:

$$\begin{aligned}
L_0 &= \frac{1}{2} \sum_{n=-\infty}^{\infty} \alpha_{-n} \cdot \alpha_n \\
&= \frac{1}{2} \alpha_0 \alpha_0 + \frac{1}{2} \sum_{n=1}^{\infty} \alpha_{-n} \cdot \alpha_n + \frac{1}{2} \sum_{n=-\infty}^{-1} \alpha_{-n} \cdot \alpha_n \\
&= \frac{1}{2} \alpha_0 \alpha_0 + \frac{1}{2} \sum_{n=1}^{\infty} \alpha_{-n} \cdot \alpha_n + \frac{1}{2} \sum_{n=1}^{\infty} \alpha_n \cdot \alpha_{-n} \\
&= \frac{1}{2} \alpha_0 \alpha_0 + \frac{1}{2} \sum_{n=1}^{\infty} \alpha_{-n} \cdot \alpha_n + \frac{1}{2} \sum_{n=1}^{\infty} \alpha_{-n} \cdot \alpha_n \\
&= \frac{1}{2} \alpha_0 \alpha_0 + \sum_{n=1}^{\infty} \alpha_{-n} \cdot \alpha_n
\end{aligned} \tag{1.75}$$

Setting this to zero, to give the vanishing of T_{++} and T_{--} , gives:

$$L_0 = \frac{1}{2} \alpha_0 \alpha_0 + \sum_{n=1}^{\infty} \alpha_{-n} \cdot \alpha_n = 0 \tag{1.76}$$

Here $\alpha_0^\mu = \sqrt{2\alpha'} p^\mu$ and $l_s = \sqrt{\alpha'}$ [1].

$$a_0^\mu = \sqrt{2} l_s p^\mu \tag{1.77}$$

$$\Rightarrow \frac{1}{2} \alpha_0 \alpha_0 = l_s^2 p^2 \tag{1.78}$$

So that:

$$L_0 \equiv l_s^2 p^2 + \sum_{n=1}^{\infty} \alpha_{-n} \cdot \alpha_n = 0 \tag{1.79}$$

$$\Rightarrow p^2 = -\frac{1}{l_s^2} \sum_{n=1}^{\infty} \alpha_{-n} \cdot \alpha_n \tag{1.80}$$

Classically, the mass-shell condition is given by the energy-momentum equation from relativity [11]:

$$M^2 = -p_\mu p^\mu = -p^2 \tag{1.81}$$

Using the above result for the momentum, this becomes [11]:

$$M^2 = \frac{1}{l_s^2} \sum_{n=1}^{\infty} \alpha_{-n} \cdot \alpha_n \tag{1.82}$$

This is the mass-shell condition for the open string.

1.7.2 The Classical Closed String Mass-Shell Condition

For the closed string, equations 1.69 and 1.70 show that T_{++} and T_{--} vanish when [1, 10, 11]:

$$L_m = \tilde{L}_m = 0 \quad m \in \mathbb{Z} \quad (1.83)$$

The zero modes are then given by:

$$L_0 = \tilde{L}_0 = 0 \quad (1.84)$$

Using the classical expressions for L_0 and \tilde{L}_0 :

$$L_0 \equiv \frac{1}{2}\alpha_0\alpha_0 + \sum_{n=1}^{\infty} \alpha_{-n} \cdot \alpha_n = 0 \quad (1.85)$$

$$\tilde{L}_0 \equiv \frac{1}{2}\tilde{\alpha}_0\tilde{\alpha}_0 + \sum_{n=1}^{\infty} \tilde{\alpha}_{-n} \cdot \tilde{\alpha}_n = 0 \quad (1.86)$$

gives:

$$p^2 = -\frac{1}{l_s^2} \sum_{n=1}^{\infty} \alpha_{-n} \cdot \alpha_n \quad (1.87)$$

$$p^2 = -\frac{1}{l_s^2} \sum_{n=1}^{\infty} \tilde{\alpha}_{-n} \cdot \tilde{\alpha}_n \quad (1.88)$$

The momentum can be written as an average of these two expressions [1]:

$$p^2 = -\frac{1}{2l_s^2} \sum_{n=1}^{\infty} (\alpha_{-n} \cdot \alpha_n + \tilde{\alpha}_{-n} \cdot \tilde{\alpha}_n) \quad (1.89)$$

Considering the zero modes, then normal ordering and redefining as in section 1.8.2, gives:

$$M^2 = \frac{1}{2l_s^2} \sum_{n=1}^{\infty} (\alpha_{-n} \cdot \alpha_n + \tilde{\alpha}_{-n} \cdot \tilde{\alpha}_n) \quad (1.90)$$

This is the mass-shell condition for the closed string.

1.8 Canonical Quantisation

Canonical quantisation is not the only method for quantising the string. It is also possible to use lightcone quantisation (which will be used later) and modern covariant quantisation (which will not). The latter is useful for describing string interactions and is analogous to the path integral formulation of quantum mechanics [14].

1.8.1 The α_n Commutation Relations

Using the canonical commutation relations (the commutators of X^μ and $\mathcal{P}^{0\mu}$), the commutators of the string oscillators α_m^μ and $\tilde{\alpha}_m^\mu$ can be proven to be [1, 10, 11]:

$$[\alpha_m^\mu, \alpha_n^\nu] = [\tilde{\alpha}_m^\mu, \tilde{\alpha}_n^\nu] = \eta^{\mu\nu} m \delta_{m+n,0} \quad (1.91)$$

$$[\alpha_m^\mu, \tilde{\alpha}_n^\nu] = [\tilde{\alpha}_m^\mu, \alpha_n^\nu] = 0 \quad (1.92)$$

1.8.2 The Redefinition of L_0

In the quantum theory L_m are promoted to operators. This introduces a normal ordering ambiguity. The convention chosen keeps α_n with negative modes n to the left of those with positive modes. In the case of L_m with $m \neq 0$ the normal ordering is easy. The normal ordered Virasoro operator is written [1, 10, 11]:

$$L_m = \frac{1}{2} \sum_{n=-\infty}^{\infty} : \alpha_{m-n} \cdot \alpha_n : \quad (1.93)$$

Equation 1.91 shows that the commutator of two α operators is only non-zero when their modes are equal and opposite in sign. This means that non-zero m guarantees that the α operators in the above expression commute. Therefore, for non-zero m , the normal ordering is a simple case of rearranging. For $m = 0$ the normal ordering is more involved. Before normal ordering, L_0 is given by:

$$\begin{aligned} L_0 &= \frac{1}{2} \sum_{n=-\infty}^{\infty} \alpha_{-n} \cdot \alpha_n \\ &= \frac{1}{2} \alpha_0 \alpha_0 + \frac{1}{2} \sum_{n=1}^{\infty} \alpha_{-n} \cdot \alpha_n + \frac{1}{2} \sum_{n=1}^{\infty} \alpha_n \cdot \alpha_{-n} \end{aligned} \quad (1.94)$$

This can be put in normal ordered form:

$$L_0 = \frac{1}{2} \alpha_0 \alpha_0 + \sum_{n=1}^{\infty} \alpha_{-n} \cdot \alpha_n + \frac{D}{2} \sum_{n=1}^{\infty} n \quad (1.95)$$

The last term is called a ‘normal ordering constant’. L_0 is now redefined such that it does not contain this constant:

$$L_0 \equiv \frac{1}{2}\alpha_0\alpha_0 + \sum_{n=1}^{\infty} \alpha_{-n} \cdot \alpha_n \quad (1.96)$$

Care must be taken when writing L_0 . The old definition of L_0 can be written in terms of the new definition, however the normal ordering constant cannot be forgotten:

$$L_0 \text{ (Old definition)} = L_0 \text{ (New definition)} + \frac{D}{2} \sum_{n=1}^{\infty} n \quad (1.97)$$

Similarly, \tilde{L}_0 can be redefined to give [1, 10, 11]:

$$\tilde{L}_0 \equiv \frac{1}{2}\tilde{\alpha}_0\tilde{\alpha}_0 + \sum_{n=1}^{\infty} \tilde{\alpha}_{-n} \cdot \tilde{\alpha}_n \quad (1.98)$$

From this point forth, the notation L_0 and \tilde{L}_0 will be reserved for the new definitions, unless stated otherwise.

1.8.3 The Virasoro Algebra

It can be shown that the modes L_m of the energy momentum-tensor, satisfy [1, 10, 11]:

$$[L_m, \alpha_n^\mu] = -n\alpha_{m+n}^\mu \quad (1.99)$$

Where L_0 is the redefined zero mode, which does not contain the normal ordering constant. This commutation relation is instrumental in proving that:

$$[L_m, L_n] = (m-n)L_{m+n} + \frac{D}{12} (m^3 - m) \delta_{m+n,0} \quad (1.100)$$

This is called the ‘Virasoro Algebra’.

1.9 Lightcone Gauge Quantisation

Lightcone gauge is described in Appendix A. The Virasoro generators and oscillators obtained in that section are used here.

The Commutation Relations

Using the same methods as for Canonical quantisation, the oscillator mode commutation relations can be derived [1, 10, 11]:

$$[\alpha_m^I, \alpha_n^J] = [\tilde{\alpha}_m^I, \tilde{\alpha}_n^J] = \eta^{IJ} m \delta_{m+n,0} \quad (1.101)$$

$$[\alpha_m^I, \tilde{\alpha}_n^J] = [\tilde{\alpha}_m^I, \alpha_n^J] = 0 \quad (1.102)$$

Also [1, 10, 11]:

$$[L_m^\perp, \alpha_n^J] = -n \alpha_{m+n}^J \quad (1.103)$$

which is instrumental in proving that [1]:

$$[L_m^\perp, L_n^\perp] = (m+n)L_{m+n}^\perp + \frac{D-2}{12} (m^3 - m) \delta_{m+n,0} \quad (1.104)$$

1.10 The Quantum Mass-Shell Condition

1.10.1 The Quantum Open String Mass-Shell Condition

It is important to find out what form the mass-shell conditions take in the quantum string theory. Particles that obey the mass-shell condition are on-shell also (they obey the classical equation of motion), and such particles are considered to be physical or ‘real’. Those that fail to satisfy the mass-shell condition are off-shell and unphysical, and play the role of virtual particles. Since the mass-shell condition tells apart physical and virtual particles it is important that it is carefully chosen for the quantum theory.

It was explained that, in the classical theory, the energy-momentum tensor vanishes on-shell. As a result $L_m = \tilde{L}_m = 0$. Since, in the quantum theory, L_m and \tilde{L}_m are promoted to operators, the naive conclusion would be that [1]:

$$L_m |\psi\rangle = \tilde{L}_m |\psi\rangle = 0 \quad (m \neq 0) \quad (1.105)$$

$$(L_0 - a) |\psi\rangle = (\tilde{L}_0 - a) |\psi\rangle = 0 \quad (1.106)$$

Recall that the redefined L_0 does not include the normal ordering constant. There is actually some ambiguity as to exactly what normal ordering constant should be used, so for now simply call it a .²

²The normal ordering constant can be chosen arbitrarily, and is fixed later by requiring the absence of negative norms states [11].

Unfortunately, the above equations together with the Virasoro algebra only permit trivial states ($|\psi\rangle = 0$). A weaker set of constraints on the modes are required. It is possible to choose that either all L_m, \tilde{L}_m with $m > 0$ annihilate the physical states or that all L_m, \tilde{L}_m with $m < 0$ annihilate the physical states. For the open string, only L_m is used. The constraints that are kept are [1]:

$$L_m |\psi\rangle = 0 \quad (m > 0) \quad (1.107)$$

$$(L_0 - a) |\psi\rangle = 0 \quad (1.108)$$

for on-shell states. This also gives [1]:

$$\langle \psi_1 | L_m | \psi_2 \rangle = 0 \quad (m > 0) \quad (1.109)$$

for on-shell states. It would have also been acceptable to choose all L_m with $m < 0$ to annihilate the physical states instead. Hermiticity of L_m ($L_m = L_m^\dagger$), together with the fact that $L_m |\psi_2\rangle = 0$, means that [1]:

$$\langle \psi_1 | L_m | \psi_2 \rangle = \langle \psi_1 | L_m^\dagger | \psi_2 \rangle = 0 \quad (1.110)$$

which means that $\langle \psi_1 | L_m^\dagger = 0$, since L_m^\dagger acts to the left.

Recall that the energy-momentum tensor was only required to vanish on-shell. Since equations 1.107 and 1.106 were obtained using the vanishing of the energy-momentum tensor, they are only true for quantum, on-shell states. Such states are referred to as ‘physical’ or ‘real’ states. For the open string only L_m is used.

Using the definition $M^2 = -p^2$, and writing the momentum in terms of the Virasoro generators, the mass-shell condition becomes [1, 10, 11]:

$$M^2 |\psi\rangle = \frac{1}{l_s^2} (N - a) |\psi\rangle \quad (1.111)$$

where

$$N \equiv \sum_{n=1}^{\infty} \alpha_{-n} \cdot \alpha_n \quad (1.112)$$

The operators are related as [1, 10, 11]:

$$M^2 = \frac{1}{l_s^2} (N - a) \quad (1.113)$$

This is the mass-shell condition for the quantum open string. Later a will be determined to equal one.

1.10.2 The Quantum Closed String Mass-Shell Condition

For the closed string both L_m and \tilde{L}_m are used, with conditions [1, 10, 11]:

$$L_m |\psi\rangle = \tilde{L}_m |\psi\rangle = 0 \quad (m \neq 0) \quad (1.114)$$

$$(L_0 - a) |\psi\rangle = (\tilde{L}_0 - a) |\psi\rangle = 0 \quad (1.115)$$

for on-shell states. Also:

$$\langle \psi_1 | L_m | \psi_2 \rangle = 0 \quad (m > 0) \quad (1.116)$$

$$\langle \psi_1 | \tilde{L}_m | \psi_2 \rangle = 0 \quad (m > 0) \quad (1.117)$$

for on-shell states. Using the definition $M^2 = -p^2$, and writing the momentum in terms of the Virasoro generators, the mass-shell condition becomes [1, 10, 11]:

$$M^2 = \frac{1}{2l_s^2} (N + \tilde{N} - 2a) \quad (1.118)$$

where:

$$N \equiv \sum_{n=1}^{\infty} \alpha_{-n} \cdot \alpha_n \quad (1.119)$$

$$\tilde{N} \equiv \sum_{n=1}^{\infty} \tilde{\alpha}_{-n} \cdot \tilde{\alpha}_n \quad (1.120)$$

As for the open string a will be determined to equal 1.

1.11 The Critical Dimension $D = 26$ and the Normal Ordering Constant $a = 1$

Rigourously proving the critical dimension and normal ordering constant for strings using covariant quantisation is difficult. However there is quite an easy *non-rigorous* way of acquiring the values of these constants in covariant quantisation using the methods of [11]. The method uses the requirement that the theory should not have any negative norm states. Specifically, it assumes that there is a ‘boundary’ between negative norm states and positive norm states, and that this boundary is characterised by the largest number of zero norm states. To find the critical value of D - equal to or below which, no negative norm states appear - it will be necessary to find the dimension which gives rise to the most zero norm states. The specifics of the method are not outlined here, but the results are:

$$a = 1 \quad D = 26 \quad (1.121)$$

Obtaining a rigorous proof is more easily achieved using lightcone quantisation. This is one of the benefits of using lightcone quantisation over canonical quantisation. Again, a specific derivation will not be shown, but the results are the same.

1.12 The Conformal Anomaly

In the classical theory it was shown that the vanishing of the trace of the energy-momentum tensor was a direct result of the conformal symmetry of the Polyakov action. In the quantum theory it is possible to show that the trace is non-zero, and, as a result, conformal symmetry is absent from the quantum theory. This is called a ‘conformal anomaly’ or, sometimes, a ‘Weyl anomaly’³.

1.13 The Open String Spectrum

It is now possible to ascertain the open string spectrum of states. It will be easiest to use lightcone gauge to obtain the string spectrum. In lightcone coordinates there exist the position operators [1]:

$$x^-, x^I \quad (1.122)$$

and the momentum operators:

$$p^+, p^I \quad (1.123)$$

where:

$$I = 2, \dots, 25 \quad (1.124)$$

Therefore, relabelling $p^I \rightarrow \vec{p}_T$ in momentum space the ground state (or vacuum state) is denoted [1]:

$$|p^+, \vec{p}_T\rangle \quad (1.125)$$

By the definition of the vacuum state, all oscillators with positive mode number annihilate this state [1]:

³In some texts ‘Weyl’ and ‘conformal’ are used almost interchangeably, despite referring to two very different transformations.

$$a_n^I |p^+, \vec{p}_T\rangle = 0 \quad (n > 0) \quad (1.126)$$

The number operator is given by:

$$N^\perp \equiv \sum_{n=1}^{\infty} n a_n^{I\dagger} \cdot a_n^I \quad (1.127)$$

It gets its name because the commutator of the number operator and creation operators is [1]:

$$[N^\perp, a_n^{I\dagger}] = n a_n^{I\dagger} \quad (1.128)$$

$$[N^\perp, a_n^I] = -n a_n^I \quad (1.129)$$

The number operators act on the vacuum to give zero. This is because the number operator is normal ordered, and the annihilation operators appear on the right [1]:

$$N^\perp |p^+, \vec{p}_T\rangle = 0 \quad (1.130)$$

In general a state will have some creation operators acting on it. In this case it is less obvious how the number operator will act. It is easiest to see how it acts with examples [1]:

$$\begin{aligned} N^\perp a_2^{I\dagger} |p^+, \vec{p}_T\rangle &= [N^\perp, a_2^{I\dagger}] |p^+, \vec{p}_T\rangle + a_2^{I\dagger} N^\perp |p^+, \vec{p}_T\rangle \\ &= 2a_2^{I\dagger} |p^+, \vec{p}_T\rangle + 0 \end{aligned} \quad (1.131)$$

Also [1]:

$$\begin{aligned} N^\perp a_3^{J\dagger} a_2^{I\dagger} |p^+, \vec{p}_T\rangle &= [N^\perp, a_3^{J\dagger}] a_2^{I\dagger} |p^+, \vec{p}_T\rangle + a_3^{J\dagger} N^\perp a_2^{I\dagger} |p^+, \vec{p}_T\rangle \\ &= 3a_3^{J\dagger} a_2^{I\dagger} |p^+, \vec{p}_T\rangle + 2a_3^{J\dagger} a_2^{I\dagger} |p^+, \vec{p}_T\rangle \\ &= 5a_3^{J\dagger} a_2^{I\dagger} |p^+, \vec{p}_T\rangle \end{aligned} \quad (1.132)$$

This shows that the number operator acts on a state to give the sum of the modes of the creation operators acting on the vacuum. More generally, it returns the mode number of the creation operators minus the mode number of the annihilation operators.

Tachyons in the spectrum

Unfortunately, the groundstate $|p^+, \vec{p}_T\rangle$ of the bosonic open string is tachyonic, having negative squared mass. Since the ground state $|p^+, \vec{p}_T\rangle$ has no spacetime indices, it corresponds to a single scalar particle. Its mass is given by [1, 11]:

$$\begin{aligned}
 M^2 |p^+, \vec{p}_T\rangle &= \frac{1}{l_s^2} (N^\perp - 1) |p^+, \vec{p}_T\rangle \\
 &= \frac{1}{l_s^2} (N^\perp - 1) |p^+, \vec{p}_T\rangle \\
 &= -\frac{1}{l_s^2} |p^+, \vec{p}_T\rangle
 \end{aligned} \tag{1.133}$$

Since l_s is a positive constant, this means that the mass squared of this particle is negative.

The Bosonic Open String Spectrum

A sample of the spectrum is given below. The table is from [1]:

Table 1: A Sample of Open Bosonic String Spectrum

N^\perp	$ \psi\rangle$	$l_s^2 M^2$	Number of States	State Type
0	$ p^+, \vec{p}_T\rangle$	-1	1	Scalar
1	$\alpha_1^{I\dagger} p^+, \vec{p}_T\rangle$	0	$D - 2 = 24$	Vector
2	$\alpha_1^{I\dagger} \alpha_1^{J\dagger} p^+, \vec{p}_T\rangle$	1	$\frac{1}{2}(D - 2)(D - 1) = 300$	Two-tensor
2	$\alpha_2^{I\dagger} p^+, \vec{p}_T\rangle$	1	$(D - 2) = 24$	Vector

1.14 The Closed String Spectrum

As in the previous section, lightcone gauge will be used. Determining the spectrum of the closed string is analogous to determining the spectrum of the open string. In this case there are left and right moving creation and annihilation operators; left movers are denoted with a tilde, whilst right movers are tilde free.

Both left and right moving annihilation operators (a_n^I and \tilde{a}_n^I) annihilate the vacuum state:

$$a_n^I |p^+, \vec{p}_T\rangle = \tilde{a}_n^I |p^+, \vec{p}_T\rangle = 0 \tag{1.134}$$

The mass operator is given by [1]:

$$M^2 = \frac{2}{l_S^2} (N^\perp + \tilde{N}^\perp - 2) \quad (1.135)$$

where number operators are given by:

$$N^\perp \equiv \sum_{n=1}^{\infty} n a_n^{I\dagger} a_n^I \quad \tilde{N}^\perp \equiv \sum_{n=1}^{\infty} n \tilde{a}_n^{I\dagger} \tilde{a}_n^I \quad (1.136)$$

It can be expected that these number operators will act on states in complete analogy to the number operator in equation 1.127. N^\perp will act on a state by giving the sum of the creation operator modes minus the sum of the annihilation operator modes as the eigenvalue. For example:

$$N^\perp a_n^J \dagger a_m^{I\dagger} |p^+, \vec{p}_T\rangle = (n + m) |p^+, \vec{p}_T\rangle \quad (1.137)$$

Similarly:

$$\tilde{N}^\perp \tilde{a}_n^J \dagger \tilde{a}_m^{I\dagger} |p^+, \vec{p}_T\rangle = (n + m) |p^+, \vec{p}_T\rangle \quad (1.138)$$

How about when N^\perp acts on a state with $\tilde{a}_m^{I\dagger}$ or when \tilde{N}^\perp acts on a state with $a_m^{I\dagger}$? The commutation relations are:

$$[N^\perp, \tilde{a}_m^{I\dagger}] = 0 \quad (1.139)$$

$$[\tilde{N}^\perp, a_m^{I\dagger}] = 0 \quad (1.140)$$

As a result M^2 acts as:

$$\begin{aligned} M^2 a_n^J \dagger \tilde{a}_m^{I\dagger} |p^+, \vec{p}_T\rangle &= \frac{2}{l_S^2} (N^\perp + \tilde{N}^\perp - 2) a_n^J \dagger \tilde{a}_m^{I\dagger} |p^+, \vec{p}_T\rangle \\ &= \frac{2}{l_S^2} \left(N^\perp a_n^J \dagger \tilde{a}_m^{I\dagger} |p^+, \vec{p}_T\rangle + \tilde{N}^\perp a_n^J \dagger \tilde{a}_m^{I\dagger} |p^+, \vec{p}_T\rangle \right. \\ &\quad \left. - 2a_n^J \dagger \tilde{a}_m^{I\dagger} |p^+, \vec{p}_T\rangle \right) \\ &= \frac{2}{l_S^2} \left((N^\perp a_n^J \dagger) \tilde{a}_m^{I\dagger} |p^+, \vec{p}_T\rangle + a_n^J \dagger (\tilde{N}^\perp \tilde{a}_m^{I\dagger}) |p^+, \vec{p}_T\rangle \right. \\ &\quad \left. - 2a_n^J \dagger \tilde{a}_m^{I\dagger} |p^+, \vec{p}_T\rangle \right) \quad (1.141) \\ &= \frac{2}{l_S^2} \left(n a_n^J \dagger \tilde{a}_m^{I\dagger} |p^+, \vec{p}_T\rangle + m a_n^J \dagger \tilde{a}_m^{I\dagger} |p^+, \vec{p}_T\rangle \right. \\ &\quad \left. - 2a_n^J \dagger \tilde{a}_m^{I\dagger} |p^+, \vec{p}_T\rangle \right) \end{aligned}$$

There is one more important consideration before samples of the spectrum can be written. The level matching condition gives [1]:

$$N^\perp = \tilde{N}^\perp \quad (1.142)$$

Only those states that respect the level matching condition contribute to the spectrum [1]. In order for the level matching to be true N^\perp and \tilde{N}^\perp must give the same eigenvalue when acting on a state. The only way that can be true is if the state consists of a vacuum acted on by a^\dagger s and \tilde{a}^\dagger s, where the mode numbers of the a^\dagger s add to the same number as the sum of the \tilde{a}^\dagger s mode numbers. For example:

$$\begin{aligned} N^\perp a_2^{I\dagger} \tilde{a}_1^{J\dagger} \tilde{a}_1^{K\dagger} |p^+, \vec{p}_T\rangle &= \left(N a_2^{I\dagger} \right) \tilde{a}_1^{J\dagger} \tilde{a}_1^{K\dagger} |p^+, \vec{p}_T\rangle \\ &= 2a_2^{I\dagger} \tilde{a}_1^{J\dagger} \tilde{a}_1^{K\dagger} |p^+, \vec{p}_T\rangle \end{aligned} \quad (1.143)$$

$$\begin{aligned} \tilde{N}^\perp a_2^{I\dagger} \tilde{a}_1^{J\dagger} \tilde{a}_1^{K\dagger} |p^+, \vec{p}_T\rangle &= a_2^{I\dagger} \left(\tilde{N}^\perp \tilde{a}_1^{J\dagger} \tilde{a}_1^{K\dagger} \right) |p^+, \vec{p}_T\rangle \\ &= 2a_2^{I\dagger} \tilde{a}_1^{J\dagger} \tilde{a}_1^{K\dagger} |p^+, \vec{p}_T\rangle \end{aligned} \quad (1.144)$$

Since both N^\perp and \tilde{N}^\perp act on the state in the same way, this state respects the level matching condition and is allowed as part of the spectrum. Note that the level matching condition means that states made of just a s or just \tilde{a} s acting on a vacuum cannot be part of the physical spectrum. This means that the next lowest level state after $|p^+, \vec{p}_T\rangle$ is $a_1^{I\dagger} \tilde{a}_1^{J\dagger} |p^+, \vec{p}_T\rangle$. Using the table from [1] the two lowest level states are then given by:

Table 2: A Sample of Closed Bosonic String Spectrum

N^\perp, \tilde{N}^\perp	$ \psi, \tilde{\psi}\rangle$	$\frac{1}{2}l_s^2 M^2$	Number of States	State Type
0, 0	$ p^+, \vec{p}_T\rangle$	-2	1	Scalar
1, 1	$\alpha_1^{I\dagger} \alpha_1^{J\dagger} p^+, \vec{p}_T\rangle$	0	$(D-2)^2 = 576$	Two-tensor

Note the ground state consists of a tachyon (a negative mass squared scalar), just as for the open bosonic string.

2 The Supersymmetric String

2.1 The Locally Supersymmetric (Supergravity) String Action

In this section the ‘locally supersymmetric string action’ (also called the ‘supergravity string action’) will be introduced. It is a generalisation of the Polyakov action that includes supersymmetry (and, therefore, fermionic degrees of freedom) whilst also incorporating gravity.

In general the worldsheet is curved (non-Euclidean). In order to consider a supersymmetric gauge theory on a curved worldsheet, supersymmetry is required to be a local symmetry of the action [15]. This is because the supersymmetry algebra generates a translation and translations are only defined locally on a curved manifold [15, 16]. In order for local supersymmetry to be achieved a spin 3/2 Rarita-Schwinger gravitino is introduced. The Rarita-Schwinger gravitino χ_A^α and the zweibein e_α^a occupy the same supergravity multiplet [15, 17]. The gravitino is a ‘vector-spinor’ [15]. It transforms as a worldsheet vector in the α index and as a worldsheet Majorana spinor in the A index.

The curved worldsheet has the group $GL(2, \mathbb{R})$ associated with it [17, 18]. Since this does not provide finite dimensional spinor representations it is necessary to consider the tangent space which has an $SO(1, 1)$ symmetry. In general, an n -dimensional curved manifold gives the group $GL(n, \mathbb{R})$, whilst the tangent space to that manifold gives the group $SO(n - 1, 1)$ [17].

At each point on the curved 2d worldsheet, it is possible to define a flat 2d Minkowski space running tangentially to the worldsheet [15, 17, 18]. The zweibein e_α^a relates the worldsheet metric $h_{\alpha\beta}$ ($\alpha, \beta = 0, 1$) to the tangent Minkowski space metric η_{ab} ($a, b = 0, 1$):

$$h_{\alpha\beta} = e_\alpha^a e_\beta^b \eta_{ab} \tag{2.1}$$

where:

$$\eta = \text{diag}(-1, 1) \tag{2.2}$$

An n -dimensional manifold has an associated n -bein which has n^2 components [17]. For the 2d case it is called a zweibein.

The locally supersymmetric (LS) action can be written:

$$\begin{aligned}
S_{LS} = & -\frac{1}{4\pi\alpha'} \int d^2\sigma \sqrt{h} \left(h^{\alpha\beta} \partial_\alpha X^\mu \partial_\beta X_\mu + \bar{\psi}^\mu \rho^\alpha \nabla_\alpha \psi_\mu \right. \\
& \left. - 2\bar{\chi}_\alpha \rho^\beta \rho^\alpha \psi^\mu \partial_\beta X_\mu - \frac{1}{2} \bar{\psi}^\mu \psi_\mu \bar{\chi}_\alpha \rho^\beta \rho^\alpha \chi_\beta \right)
\end{aligned} \tag{2.3}$$

The Dirac conjugates are given by [11, 19]:

$$\bar{\psi} = i\psi^\dagger \rho^0 \tag{2.4}$$

The spinors are Majorana and are given by $\psi^\mu = \psi_A^\mu$, $A = -, +$ [11]:

$$\psi_A^\mu = \begin{pmatrix} \psi_-^\mu \\ \psi_+^\mu \end{pmatrix} \tag{2.5}$$

where [11]:

$$\psi_+^* = \psi_+, \quad \psi_-^* = \psi_- \tag{2.6}$$

That is, the components are real. Since the hermitian conjugate (denoted by \dagger) is the combined action of transposition and complex conjugation, and since ψ is real, it follows that:

$$\psi^\dagger = \psi^T \Rightarrow \bar{\psi} = \psi^T i\rho^0 \tag{2.7}$$

ρ^α are the 2d curved space (curved worldsheet) Dirac matrices given by the zweibeins times the flat space 2d Dirac matrices [15]:

$$\rho^\alpha = e_a^\alpha \rho^a \tag{2.8}$$

where ρ^a ($a = 0, 1$) are the flatspace 2d Dirac matrices. As before, Greek indices represent objects in curved spacetime, whilst Latin indices represent those in flat spacetime. The flat space 2d Dirac matrices are:

$$\rho^0 = \begin{pmatrix} 0 & -1 \\ 1 & 0 \end{pmatrix} \quad \text{and} \quad \rho^1 = \begin{pmatrix} 0 & 1 \\ 1 & 0 \end{pmatrix} \tag{2.9}$$

∇_α is the covariant spinor derivative given by [15, 19, 20, 21, 22]:

$$\nabla_\alpha \psi_\mu = \partial_\alpha \psi_\mu - \frac{1}{4} \omega_\alpha^{ab} \gamma_{ab} \psi_\mu \quad (2.10)$$

ω_α^{ab} is the spin connection. When one considers spinors as sections of a spinor bundle, the spin connection defines parallel transport on the fibre bundle. The spin connection is given by [20, 21, 22]:

$$\omega_\alpha^{ab} = e_\beta^a \partial_\alpha e^{\beta b} + e_\beta^a e^{\gamma b} \Gamma_{\gamma\alpha}^\beta \quad (2.11)$$

where $\Gamma_{\gamma\alpha}^\beta$ is the ‘affine connection’.

The covariant spinor derivative in the case of 2d Majorana spinors is given by $\rho^\alpha \nabla_\alpha \psi \equiv \rho^\alpha \partial_\alpha \psi$. The action can then be written [15]:

$$\begin{aligned} S_{LS} = -\frac{1}{2\pi} \int d^2\sigma \sqrt{h} & \left(h^{\alpha\beta} \partial_\alpha X^\mu \partial_\beta X_\mu + \bar{\psi}^\mu \rho^\alpha \partial_\alpha \psi_\mu \right. \\ & \left. - 2e\bar{\chi}_\alpha \rho^\beta \rho^\alpha \psi^\mu \partial_\beta X_\mu - \frac{1}{2} e \bar{\psi}_\mu \psi^\mu \bar{X}_\alpha \rho^\beta \rho^\alpha \chi_\beta \right) \end{aligned} \quad (2.12)$$

2.2 The RNS Superstring Action

2.2.1 The RNS String Action from the Locally Supersymmetric Worldsheet Action

Just as the Polyakov action could be put into conformal gauge, the locally supersymmetric action can be put into ‘superconformal gauge’ to obtain the RNS (Ramond-Neveu-Schwarz) superstring action [15].

Superconformal Gauge

The procedure is as follows:

1) The worldsheet metrics is made flat. This is achieved in the same way as for the Nambu-Goto and Polyakov actions [15]. First reparameterisation invariance means that the metric can be written in conformally flat form. Reparameterisation invariance allows the worldsheet invariant interval to be written as [7, 17]:

$$ds^2 = h_{\alpha\beta} \sigma^\alpha \sigma^\beta \rightarrow e^{-2\Lambda(\sigma)} (-(d\sigma^0)^2 + (d\sigma^1)^2) = e^{-2\Lambda(\sigma)} \eta_{\alpha\beta} \sigma^\alpha \sigma^\beta \quad (2.13)$$

Therefore reparameterisation gives:

$$h_{\alpha\beta} \rightarrow e^{-2\Lambda(\sigma)} \eta_{\alpha\beta} \quad (2.14)$$

In this form the metric is said to be ‘conformally flat’. This can be used in conjunction with the Weyl transformation $h_{\alpha\beta}(\sigma) \rightarrow e^{2\Lambda(\sigma)} h_{\alpha\beta}(\sigma)$ to give:

$$h_{\alpha\beta} \rightarrow \eta_{\alpha\beta} \quad (2.15)$$

For the Polyakov action this is sufficient to bring it to conformal gauge. To bring the locally supersymmetric action to superconformal gauge there are two more steps [15].

2) The zweibein can be brought to the form [15]:

$$e_{\alpha}^a = \delta_{\alpha}^a \quad (2.16)$$

This is achieved using the bosonic symmetries of the worldsheet, corresponding to two coordinate transformations, one local Lorentz transformation, and one Weyl transformation. These four symmetries are used to constrain the four components of the zweibein. This form of the zweibein means that [15]:

$$\rho^{\alpha} = \delta_a^{\alpha} \rho^a \quad (2.17)$$

Therefore the curved space Dirac matrices ρ^{α} can be written:

$$\rho^0 = \begin{pmatrix} 0 & -1 \\ 1 & 0 \end{pmatrix} \quad \text{and} \quad \rho^1 = \begin{pmatrix} 0 & 1 \\ 1 & 0 \end{pmatrix} \quad (2.18)$$

3) Since there are also four fermionic symmetries, corresponding to two supersymmetry transformations with parameter ϵ_A , and two superconformal transformations with parameter η , all four components of χ can be set to zero [15]. When all these steps are taken, the locally supersymmetric string action is put into superconformal gauge, and the RNS superstring action is obtained [15, 19]:

$$S_{RNS} = - \frac{1}{4\pi\alpha'} \int d^2\sigma \eta^{ab} (\partial_a X^{\mu} \partial_b X_{\mu} + \bar{\psi}^{\mu} \rho_a \partial_b \psi_{\mu}) \quad (2.19)$$

Alternatively, step (1) from above can be skipped, leading to the alternative form of the RNS action that appears in the literature:

$$S_{RNS} = - \frac{1}{4\pi\alpha'} \int d^2\sigma \sqrt{-h} h^{\alpha\beta} (\partial_{\alpha} X^{\mu} \partial_{\beta} X_{\mu} + \bar{\psi}^{\mu} \rho_{\alpha} \partial_{\beta} \psi_{\mu}) \quad (2.20)$$

2.2.2 The RNS Action as the Supersymmetric Generalisation of the Polyakov Action

The RNS action can be seen as the Polyakov action with the inclusion of worldsheet supersymmetry. Consider the Polyakov action:

$$S_P = -\frac{1}{4\pi\alpha'} \int d^2\sigma \sqrt{-h} h^{\alpha\beta} \partial_\alpha X^\mu \partial_\beta X^\nu \eta_{\mu\nu} \quad (2.21)$$

In conformal gauge $h_{\alpha\beta} = \eta_{\alpha\beta}$, giving [7]:

$$\begin{aligned} S_P &= -\frac{1}{4\pi\alpha'} \int d^2\sigma \eta^{\alpha\beta} \partial_\alpha X^\mu \partial_\beta X^\nu \eta_{\mu\nu} \\ &= -\frac{1}{4\pi\alpha'} \int d^2\sigma \partial_\alpha X^\mu \partial^\alpha X^\nu \eta_{\mu\nu} \\ &= -\frac{1}{4\pi\alpha'} \int d^2\sigma \partial_\alpha X_\mu \partial^\alpha X^\mu \end{aligned} \quad (2.22)$$

In order to include fermions into the action a term corresponding to the Dirac action of D free massless two-dimensional Majorana fermions are added [11, 19]. The form of the Dirac action is simply:

$$\bar{\psi}^\mu \not{\partial} \psi_\mu = \bar{\psi}^\mu \rho^\alpha \partial_\alpha \psi_\mu \quad (2.23)$$

where $\alpha = 0, 1$, $\mu = 0, \dots, D$ and $\bar{\psi} = \psi^\dagger i\rho^0$ [11]. The RNS superstring action can be seen as either the locally supersymmetric action in superconformal gauge, or as the Polyakov action (in conformal gauge) with the Dirac term added:

$$S_{RNS} = -\frac{1}{4\pi\alpha'} \int d^2\sigma (\partial_\alpha X_\mu \partial^\alpha X^\mu + \bar{\psi}^\mu \rho^\alpha \partial_\alpha \psi_\mu) \quad (2.24)$$

2.2.3 The RNS Action in Lightcone Coordinates

Calculations are often simplified by using lightcone coordinates. The RNS action in lightcone coordinates is given by:

$$S_{RNS} = \frac{1}{2\pi\alpha'} \int d^2\sigma (2\partial_+ X_\mu \partial_- X^\mu + i\psi_- \partial_+ \psi_- + i\psi_+ \partial_- \psi_+) \quad (2.25)$$

The Dirac equations are then written [11]:

$$\partial_+ \psi_- = \partial_- \psi_+ = 0 \quad (2.26)$$

2.2.4 Supersymmetry of the RNS Action

It is important to understand what sort of supersymmetry exists on the worldsheet of the superstring. The type of supersymmetry (e.g. $N = 1$, $N = 2$ etc.), the number of supercharges and the real dimension of the minimal spinor representation are related by:

$$\begin{aligned} \text{Number of supercharges} &= \text{Real dimension of minimal spinor} \\ &\times \text{Number of supersymmetries (N)} \end{aligned} \quad (2.27)$$

In (1,1)d (on the worldsheet) the minimal spinor representation is the one real dimensional Majorana-Weyl spinor representation of the Lorentz group $Spin(1,1)$ [11, 23], the number of supercharges is two (given by Q_A with spinor indices $A = 1, 2$) [11], and this all corresponds an $N = 2$ worldsheet supersymmetry [24, 25].

The RNS action is invariant under the supersymmetry transformations:

$$\begin{aligned} \delta X^\mu (\sigma^\alpha) &= \bar{\epsilon} \psi^\mu (\sigma^\alpha) \\ \delta \psi^\mu (\sigma^\alpha) &= \rho^\alpha (\partial_\alpha X^\mu (\sigma^\alpha)) \epsilon \end{aligned} \quad (2.28)$$

These can be written in lightcone coordinates as [11]:

$$\begin{aligned} \delta X^\mu &= \bar{\epsilon} \psi^\mu \\ &= i (\epsilon_+ \psi_-^\mu - \epsilon_- \psi_+^\mu) \end{aligned} \quad (2.29)$$

$$\begin{aligned} \delta \psi^\mu &= \rho^\alpha \partial_\alpha X^\mu \epsilon \\ \Rightarrow \delta \psi_-^\mu &= -2 \partial_- X^\mu \epsilon_+ \\ \Rightarrow \delta \psi_+^\mu &= 2 \partial_+ X^\mu \epsilon_- \end{aligned}$$

2.3 The Energy-Momentum Tensor of the RNS string

The energy-momentum tensor is the conserved current associated with the translational symmetry of the RNS action [11]. It is given by:

$$\begin{aligned} T_{\alpha\beta} &= \partial_\alpha X^\mu \partial_\beta X_\mu - \frac{1}{2} \eta_{\alpha\beta} \partial_\gamma X^\mu \partial^\gamma X_\mu \\ &\quad + \frac{1}{4} \bar{\psi}^\mu \rho_\alpha \partial_\beta \psi_\mu + \frac{1}{4} \bar{\psi}^\mu \rho_\beta \partial_\alpha \psi_\mu - \frac{1}{4} \eta_{\alpha\beta} \bar{\psi}^\mu \rho^\gamma \partial_\gamma \psi_\mu \end{aligned} \quad (2.30)$$

In lightcone coordinates this is written [11]:

$$\begin{aligned}
T_{++} &= \partial_+ X_\mu \partial_+ X^\mu + \frac{i}{2} \psi_+^\mu \partial_+ \psi_{+\mu} \\
T_{--} &= \partial_- X_\mu \partial_- X^\mu + \frac{i}{2} \psi_-^\mu \partial_- \psi_{-\mu}
\end{aligned}
\tag{2.31}$$

$$T_{+-} = T_{-+} = 0$$

In lightcone coordinates the energy-momentum tensor obeys the conservation law [11, 10]:

$$\partial_- T_{++} = \partial_- T_{--} = 0 \tag{2.32}$$

This is proven using the equations of motion:

$$\partial_+ \partial_- X^\mu = 0, \quad \partial_+ \psi_-^\mu = \partial_- \psi_+^\mu = 0 \tag{2.33}$$

2.4 The Supercurrent of the RNS String

The supercurrent is the conserved current associated with the global supersymmetry of the RNS action [11]. It is given by:

$$J^\alpha = -\frac{1}{2} \rho^\beta \rho^\alpha \psi_\mu \partial_\beta X^\mu \tag{2.34}$$

The supercurrent satisfies:

$$(\rho_\alpha)_{AB} J_B^\alpha = 0 \tag{2.35}$$

It also satisfies the conservation equation:

$$\partial_\alpha J_A^\alpha = 0 \tag{2.36}$$

The supercurrent has two independent components. In lightcone coordinates these are given by [11]:

$$J_+ = \psi_+^\mu \partial_+ X_\mu \tag{2.37}$$

$$J_- = \psi_-^\mu \partial_- X_\mu$$

These then satisfy the conservation equations:

$$\partial_- J_+ = \partial_+ J_- = 0 \tag{2.38}$$

The variation of the RNS action with respect to the metric gives the vanishing of the energy-momentum tensor, whilst the variation of the locally supersymmetric action with respect to the Rarita-Schwinger field (then choosing superconformal gauge) gives the vanishing of the supercurrent [11]. Alternatively the locally supersymmetric action can be varied with respect to the zweibein, then superconformal gauge can be chosen, leading to the vanishing of the energy-momentum tensor [15]. Together these give the super-Virasoro constraints:

$$T_{++} = T_{--} = J_+ = J_- = 0 \tag{2.39}$$

This is only a restriction of the on-shell theory.

2.5 Solutions to the Wave Equation

It is now possible to discuss the classical solutions of the wave equation. These solutions will be built upon to eventually lead to the quantum results and a particle spectrum.

2.5.1 Open String

Here the open string solutions to the wave equation are stated.

The Bosonic Fields

In the bosonic string theory section 1.5.1 it was shown that the open bosonic string gives the following conditions:

Open String with Neumann Boundary Conditions at Both Ends

$$X^\mu(\tau, \sigma) = x^\mu + 2l_s^2 p^\mu \tau + i\sqrt{2}l_s \sum_{m \neq 0} \frac{\alpha_m^\mu}{m} e^{-im\tau} \cos(m\sigma) \tag{2.40}$$

Open String with Dirichlet Boundary Conditions at Both Ends

$$X^\mu(\tau, \sigma) = x^\mu + 2l_s^2 p^\mu \sigma - i\sqrt{2}l_s \sum_{m \neq 0} \frac{\alpha_m^\mu}{m} e^{-im\tau} \sin(m\sigma) \quad (2.41)$$

The Fermionic Fields

It is easier to work in lightcone coordinates. The fermionic part of the RNS action is given by [10, 11]:

$$S_f = \frac{i}{2\pi\alpha'} \int d^2\sigma (\psi_- \partial_+ \psi_- + \psi_+ \partial_- \psi_+) \quad (2.42)$$

By varying the action with respect to the fermionic fields, the following condition is obtained [10, 11]:

$$[\psi_+ \delta\psi_+ - \psi_- \delta\psi_-]_{\sigma=0} = [\psi_+ \delta\psi_+ - \psi_- \delta\psi_-]_{\sigma=\pi} = 0 \quad (2.43)$$

This is satisfied if [10, 11]:

$$\psi_+^\mu(\tau, 0) = \psi_-^\mu(\tau, 0) \text{ or } \psi_+^\mu(\tau, 0) = -\psi_-^\mu(\tau, 0) \quad (2.44)$$

and if:

$$\psi_+^\mu(\tau, \pi) = \psi_-^\mu(\tau, \pi) \text{ or } \psi_+^\mu(\tau, \pi) = -\psi_-^\mu(\tau, \pi) \quad (2.45)$$

The relative sign of ψ_+^μ and ψ_-^μ is not physically important in and of itself. What is of physical importance is if the relative sign between ψ_+^μ and ψ_-^μ at $\sigma = 0$ is the same as the relative sign between ψ_+^μ and ψ_-^μ at $\sigma = \pi$ [10, 11]. Therefore, following common convention, the condition [10, 11]:

$$\psi_+^\mu(\tau, 0) = \psi_-^\mu(\tau, 0) \quad (2.46)$$

is chosen. Subsequently the choice of relative sign of ψ_+^μ and ψ_-^μ at $\sigma = \pi$ corresponds to two different physical outcomes:

Ramond Boundary Condition

In this case the $\sigma = \pi$ end of the string has [10, 11]:

$$\psi_+^{\mu(R)}(\tau, \pi) = \psi_-^{\mu(R)}(\tau, \pi) \quad (2.47)$$

This choice gives the so-called Ramond sector, or ‘R sector’, indicated by the superscript ‘(R)’. Writing the fermions as vectors in an infinite dimensional Hilbert space gives the mode expansions [10, 11]:

$$\begin{aligned}\psi_+^{\mu(R)}(\tau, \sigma) &= \frac{1}{\sqrt{2}} \sum_n d_n^\mu e^{-in(\tau+\sigma)} \\ \psi_-^{\mu(R)}(\tau, \sigma) &= \frac{1}{\sqrt{2}} \sum_n d_n^\mu e^{-in(\tau-\sigma)}\end{aligned}\tag{2.48}$$

where $n = 0, \pm 1, \pm 2, \dots$. It will be shown later that the R sector gives rise to spacetime fermions [10, 11].

Neveu-Schwarz Boundary Condition

In this case the $\sigma = \pi$ end of the string has [10, 11]:

$$\psi_+^{\mu(NS)}(\tau, \pi) = -\psi_-^{\mu(NS)}(\tau, \pi)\tag{2.49}$$

This choice gives the so-called Neveu-Schwarz sector, or ‘NS sector’, indicated by the superscript ‘(NS)’.

Writing the fermions as vectors in an infinite dimensional Hilbert space gives the mode expansions [10, 11]:

$$\begin{aligned}\psi_+^{\mu(NS)}(\tau, \sigma) &= \frac{1}{\sqrt{2}} \sum_r b_r^\mu e^{-ir(\tau+\sigma)} \\ \psi_-^{\mu(NS)}(\tau, \sigma) &= \frac{1}{\sqrt{2}} \sum_r b_r^\mu e^{-ir(\tau-\sigma)}\end{aligned}\tag{2.50}$$

where $r = \pm 1/2, \pm 3/2, \pm 5/2, \dots$. It will be shown later that the NS sector gives rise to spacetime bosons [10, 11].

2.5.2 Closed String

Here the closed string solutions to the wave equation are stated.

The Bosonic Fields

In the Bosonic String Theory section 1.5.2 it was shown that, for the closed string:

$$X_R^\mu = \frac{x_0^\mu}{2} + l_s^2 p^\mu (\tau - \sigma) + \frac{i}{\sqrt{2}} l_s \sum_{n \neq 0} \frac{\alpha_n^\mu}{n} e^{-in(\tau - \sigma)} \quad (2.51)$$

$$X_L^\mu = \frac{x_0^\mu}{2} + l_s^2 p^\mu (\tau + \sigma) + \frac{i}{\sqrt{2}} l_s \sum_{n \neq 0} \frac{\tilde{\alpha}_n^\mu}{n} e^{-in(\tau + \sigma)} \quad (2.52)$$

$$\begin{aligned} X^\mu(\tau, \sigma) &= X_R^\mu + X_L^\mu \\ &= x_0^\mu + 2l_s^2 p^\mu \tau + \frac{i}{\sqrt{2}} l_s \sum_{n \neq 0} \frac{e^{-2in\tau}}{n} (\alpha_n^\mu e^{2in\sigma} + \tilde{\alpha}_n^\mu e^{-2in\sigma}) \end{aligned} \quad (2.53)$$

The Fermionic Fields

Closed strings possess either periodic or anti-periodic boundary conditions. For a string of length π , the periodic boundary condition on the left movers is [10, 11]:

$$\psi_+^{(R)}(\tau, \sigma) = \psi_+^{(R)}(\tau, \sigma + \pi) \quad (2.54)$$

and the periodic boundary condition on right movers is:

$$\psi_-^{(R)}(\tau, \sigma) = \psi_-^{(R)}(\tau, \sigma + \pi) \quad (2.55)$$

Similarly, the anti-periodic boundary condition on the left movers is:

$$\psi_+^{(NS)}(\tau, \sigma) = -\psi_+^{(NS)}(\tau, \sigma + \pi) \quad (2.56)$$

and anti-periodic boundary condition on right movers is:

$$\psi_-^{(NS)}(\tau, \sigma) = -\psi_-^{(NS)}(\tau, \sigma + \pi) \quad (2.57)$$

The periodic boundary conditions correspond to the R sector, whilst anti-periodic boundary conditions correspond to the NS sector [11]. However, these can be chosen independently for right and for left movers. Therefore, the closed string has four sectors: R-R, NS-NS, R-NS, and, NS-R. States in R-R or NS-NS will give rise to spacetime bosons, whilst states in R-NS and NS-R will give rise to spacetime fermions.

2.6 Canonical Quantisation

So far the classical theory of the superstring has been considered. The next step will be to quantise. However, in order to do this, the super-Virasoro operators need to be ascertained.

2.6.1 The Super-Virasoro Generators of the Open String

The Super-Virasoro generators are given by $L_m^{(R)}$, $L_m^{(NS)}$, F_m and G_r [10, 11, 26].

These are explained below.

$L_m^{(R)}$ Generators of the Open String

The generators $L_m^{(R)}$ are the modes of the energy momentum tensor $T_{\alpha\beta}$ in the R-sector, given by [11]:

$$L_m^{(R)} = \frac{1}{\pi} \int_{-\pi}^{\pi} d\sigma e^{im\sigma} T_{++} = L_m^b + L_m^{f(R)} \quad (2.58)$$

where L_m^b are the contributions of bosonic modes and $L_m^{f(R)}$ are the contributions of fermionic modes belonging to the R sector [11, 10]. The bosonic contributions are given by [11]:

$$L_m^b = \frac{1}{2} \sum_n : \alpha_{-n} \cdot \alpha_{m+n} : \quad (2.59)$$

with $m, n \in \mathbb{Z}$.

The R sector fermionic mode contribution is given by [11]:

$$L_m^{f(R)} = \frac{1}{2} \sum_n \left(n + \frac{m}{2} \right) : d_{-n} \cdot d_{m+n} : \quad (2.60)$$

with $m, n \in \mathbb{Z}$.

$L_m^{(NS)}$ Generators of the Open String

The generators $L_m^{(NS)}$ are the modes of the energy momentum tensor $T_{\alpha\beta}$ in the NS sector, given by [11]:

$$L_m^{(NS)} = \frac{1}{\pi} \int_{-\pi}^{\pi} d\sigma e^{im\sigma} T_{++} = L_m^b + L_m^{f(NS)} \quad (2.61)$$

As before, the bosonic contribution is given by [11]:

$$L_m^b = \frac{1}{2} \sum_n : \alpha_{-n} \cdot \alpha_{m+n} : \quad (2.62)$$

with $m, n \in \mathbb{Z}$.

The NS sector fermionic mode contribution is given by [11]:

$$L_m^{f(\text{NS})} = \frac{1}{2} \sum_r \left(r + \frac{m}{2} \right) : b_{-r} \cdot b_{m+r} : \quad (2.63)$$

with $m \in \mathbb{Z}$ and $r \in \mathbb{Z} + 1/2$.

F_m Generators of the Open String

The generators F_m are the modes of the supercurrent J_α in the R sector, given by [11]:

$$F_m = \frac{\sqrt{2}}{\pi} \int_{-\pi}^{\pi} d\sigma e^{im\sigma} J_+ = \sum_n \alpha_{-n} \cdot d_{m+n} \quad (2.64)$$

with $m, n \in \mathbb{Z}$.

G_r Generators of the Open String

The generators G_r are the modes of the supercurrent J_α in the NS sector, given by [11]:

$$G_r = \frac{\sqrt{2}}{\pi} \int_{-\pi}^{\pi} d\sigma e^{ir\sigma} J_+ = \sum_n \alpha_{-n} \cdot b_{r+n} \quad (2.65)$$

with $m \in \mathbb{Z}$ and $r \in \mathbb{Z} + 1/2$.

2.6.2 The Super-Virasoro Algebras of the Open String

Using the expressions for $L_m^{(\text{R})}$, $L_m^{(\text{NS})}$, F_m and G_r , the algebras in the Ramond sector are written [10, 11, 26]:

$$[L_m^{(\text{R})}, L_n^{(\text{R})}] = (m - n)L_{m+n}^{(\text{R})} + \frac{D}{8} m^3 \delta_{m+n,0} \quad (2.66)$$

$$[L_m^{(\text{R})}, F_n] = \left(\frac{m}{2} - n \right) F_{m+n} \quad (2.67)$$

$$[F_m, F_n] = 2L_{m+n}^{(\text{R})} + \frac{D}{2} m^2 \delta_{m+n,0} \quad (2.68)$$

In the above three equations $m, n \in \mathbb{Z}$. Similarly, the algebras in the Neveu-Schwarz sector are written [10, 11, 26]:

$$[L_m^{(\text{NS})}, L_n^{(\text{NS})}] = (m - n)L_{m+n}^{(\text{NS})} + \frac{D}{8} m(m^2 - 1) \delta_{m+n,0} \quad (2.69)$$

$$[L_m^{(\text{NS})}, G_r] = \left(\frac{m}{2} - r \right) G_{m+r} \quad (2.70)$$

$$[G_r, G_s] = 2L_{r+s}^{(\text{NS})} + \frac{D}{2} \left(r^2 - \frac{1}{4} \right) \delta_{r+s,0} \quad (2.71)$$

In the above three equations $r, s \in \mathbb{Z} + 1/2$.

2.7 The Quantum Mass-Shell Conditions

2.7.1 The Quantum Open String Mass-Shell Condition

Following the procedures of canonical quantisation, positive modes annihilate the ground states $|\psi\rangle$ [11, 20].

R-Sector

$$a_m^\mu |\psi\rangle = 0 \quad (m > 0) \quad (2.72)$$

$$d_n^\mu |\psi\rangle = 0 \quad (n > 0) \quad (2.73)$$

This implies that [10, 11]:

$$L_m |\psi\rangle = 0 \quad (m > 0) \quad (2.74)$$

$$F_n |\psi\rangle = 0 \quad (n > 0) \quad (2.75)$$

$$(L_0 - a_R) |\psi\rangle = 0 \quad (2.76)$$

Using $M^2 = -p^2$, and writing the momentum in terms of the Virasoro generators, the R-sector mass-shell condition is given by [10, 11]:

$$\alpha' M^2 = \sum_{n=1}^{\infty} \alpha_{-n}^I \alpha_n^I + \sum_{n=1}^{\infty} n d_{-n}^I d_n^I - a_R \quad (2.77)$$

NS-Sector

$$a_m^\mu |\psi\rangle = 0 \quad (m > 0) \quad (2.78)$$

$$b_r^\mu |\psi\rangle = 0 \quad (r > 0) \quad (2.79)$$

This implies that [10, 11]:

$$L_m |\psi\rangle = 0 \quad (m > 0) \quad (2.80)$$

$$G_r |\psi\rangle = 0 \quad (r > 0) \quad (2.81)$$

$$(L_0 - a_{NS}) |\psi\rangle = 0 \quad (2.82)$$

Using $M^2 = -p^2$, and writing the momentum in terms of the Virasoro generators, the NS-sector mass-shell condition is given by [10, 11]:

$$\alpha' M^2 = \sum_{n=1}^{\infty} \alpha_{-n}^I \alpha_n^I + \sum_{r=1/2}^{\infty} r b_{-r}^I b_r^I - a_{NS} \quad (2.83)$$

2.7.2 The Quantum Closed String Mass-Shell Condition

As was the case with the bosonic string, the Virasoro constraints are identical for the open string and the closed string. The only difference is that, for the closed string, there are two (left and right moving) versions of each Virasoro operator.

Following the methods employed for the bosonic string, the mass-shell condition is taken as the average of the left and right moving mass-shell conditions, where each left and right moving condition is as written for the open string. However, there are two mass-shell conditions for the opens string, one for the R-sector and one for the NS-sector. Combinations of these gives four mass-shell conditions, one for each sector of the closed string [27]:

R-R Sector

$$a' M^2 = \frac{1}{2} \left(\sum_{n=1}^{\infty} \tilde{\alpha}_{-n}^I \tilde{\alpha}_n^I + \sum_{n=1}^{\infty} n \tilde{d}_{-n}^I \tilde{d}_n^I + \sum_{n=1}^{\infty} \alpha_{-n}^I \alpha_n^I + \sum_{n=1}^{\infty} n d_{-n}^I d_n^I - 2a_R \right) \quad (2.84)$$

R-NS Sector

$$a' M^2 = \frac{1}{2} \left(\sum_{n=1}^{\infty} \tilde{\alpha}_{-n}^I \tilde{\alpha}_n^I + \sum_{n=1}^{\infty} n \tilde{d}_{-n}^I \tilde{d}_n^I - a_R + \sum_{n=1}^{\infty} \alpha_{-n}^I \alpha_n^I + \sum_{r=1/2}^{\infty} r b_{-r}^I b_r^I - a_{NS} \right) \quad (2.85)$$

NS-R Sector

$$a'M^2 = \frac{1}{2} \left(\sum_{n=1}^{\infty} \tilde{\alpha}_{-n}^I \tilde{\alpha}_n^I + \sum_{r=1/2}^{\infty} r \tilde{b}_{-r}^I \tilde{b}_r^I - a_{NS} + \sum_{n=1}^{\infty} \alpha_{-n}^I \alpha_n^I + \sum_{n=1}^{\infty} n d_{-n}^I d_n^I - a_R \right) \quad (2.86)$$

NS-NS Sector

$$a'M^2 = \frac{1}{2} \left(\sum_{n=1}^{\infty} \tilde{\alpha}_{-n}^I \tilde{\alpha}_n^I + \sum_{r=1/2}^{\infty} r \tilde{b}_{-r}^I \tilde{b}_r^I + \sum_{n=1}^{\infty} \alpha_{-n}^I \alpha_n^I + \sum_{r=1/2}^{\infty} r b_{-r}^I b_r^I - 2a_{NS} \right) \quad (2.87)$$

2.8 The Open String Spectrum

It is now possible to determine the open superstring spectrum of states. These states belong to either the NS or R-sector.

The Neveu-Schwarz Sector

The mass-shell condition is [10, 11]:

$$\alpha' M^2 = \sum_{n=1}^{\infty} \alpha_{-n}^I \alpha_n^I + \sum_{r=1/2}^{\infty} r b_{-r}^I b_r^I - a_{NS} \quad (2.88)$$

where $I = 2, \dots, 10$ are the transverse coordinates. The ground state $|0; k\rangle_{NS}$ is defined as the state which gives zero when acted on by annihilation operators [10, 11]:

$$\alpha_n^I |0; k\rangle_{NS} = b_r^I |0; k\rangle_{NS} = 0 \quad n, r > 0 \quad (2.89)$$

$$\alpha_0^\mu |0; k\rangle_{NS} = \sqrt{2\alpha'} k^\mu |0; k\rangle_{NS} \quad (2.90)$$

As a result the groundstate $|0; k\rangle_{NS}$ gives:

$$\begin{aligned} \alpha' M^2 |0; k\rangle_{NS} &= \sum_{n=1}^{\infty} \alpha_{-n}^I \alpha_n^I |0; k\rangle_{NS} + \sum_{r=1/2}^{\infty} r b_{-r}^I b_r^I |0; k\rangle_{NS} - a_{NS} |0; k\rangle_{NS} \\ &= -a_{NS} |0; k\rangle_{NS} \end{aligned} \quad (2.91)$$

The first excited state is given by:

$$b_{-1/2}^I |0; k\rangle_{NS} \quad (2.92)$$

Since the state transforms under $SO(8)$ (it has $8 = D - 2$ components) it must be massless. This provides a means with which to verify that $a_{NS} = 1/2$. Acting on the vector state with $\alpha' M^2$ gives [10, 11]:

$$\alpha' M^2 b_{-1/2}^I |0; k\rangle_{NS} = \frac{1}{2} - a_{NS} \quad (2.93)$$

which is zero iff $a_{NS} = 1/2$. Using this result in equation 2.91 gives $\alpha' M^2 = -1/2$ for the groundstate. Therefore, as was the case for the bosonic string, the groundstate is a tachyon. GSO projection removes this state by removing all states with negative ‘G-parity’, where G-parity is given by [10, 11]:

$$G = (-1)^{F+1} = (-1)^{\sum_{r=1/2}^{\infty} b_{-r}^I b_r^{I+1}} \quad (2.94)$$

The Ramond Sector

The mass-shell condition is [10, 11]:

$$\alpha' M^2 = \sum_{n=1}^{\infty} \alpha_{-n}^I \alpha_n^I + \sum_{n=1}^{\infty} n d_{-n}^I d_n^I + a_R \quad (2.95)$$

where:

$$a_R = 0 \quad (2.96)$$

The groundstates satisfy [10, 11]:

$$\alpha_n^I |0; k\rangle_R = d_n^i |0; k\rangle_R = 0 \quad n > 0 \quad (2.97)$$

The groundstate is an irreducible Majorana-Weyl spinor of $Spin(8)$ (corresponding to the irreducible spinor of eight dimensional Euclidean space), with eight degrees of freedom ⁴ [11, 28, 29, 30]. Acting on the groundstate by $\alpha' M^2$ gives:

$$\begin{aligned} \alpha' M^2 &= \sum_{n=1}^{\infty} \alpha_{-n}^I \alpha_n^I |0; k\rangle_R + \sum_{n=1}^{\infty} n d_{-n}^I d_n^I |0; k\rangle_R + a_R |0; k\rangle_R \\ &= 0 |0; k\rangle_R + 0 |0; k\rangle_R + 0 |0; k\rangle_R \end{aligned} \quad (2.98)$$

So the groundstate spinor is massless.

The first excited state is a spacetime spinor obtained by acting on the groundstate spinor $|0; k\rangle_R$ with either the vector creation operator α_{-n}^I or d_{-n}^I [11].

⁴In the 10d spacetime, the irreducible spinor is Majorana-Weyl, giving it $((2^{D/2})/2)/2 = 8$ independent fermionic components [11]. The two divisions by two are from consecutive Majorana and Weyl conditions.

2.9 The Closed String Spectrum

As with the open string there are Neveu-Schwarz and Ramond sectors, however in this case the left moving and right moving degrees of freedom of the string are independent giving rise to four combinations, NS-NS, NS-R, R-NS and R-R [10, 11].

In contrast with the open string, which projected out the negative G-parity states, positive G-parity states are projected out of the NS-sector in order to remove the closed string tachyon [10, 11]. However, like the open string, there is a choice as to whether positive or negative G-parity states of the R-sector are projected out. Two types of theory result; ones in which the left and right moving R-sectors have the same G-parity states projected out, and ones in which left and right moving R-sectors have opposite G-parity states projected out. IIA theories have opposite chirality for the surviving left and right moving R-sector states, and opposite G-parity for left and right moving R-sector states. IIB theories have the same chirality for the surviving left and right moving R-sector states, and the same G-parity for left and right moving R-sector states. The R-sector ground states will be denoted $|0; k\rangle_{+R}$ and $|0; k\rangle_{-R}$ for positive chirality and negative chirality respectively.

IIA Closed String Spectrum

In the IIA theory the left and right moving R-sectors have opposite chirality. Using [11]: After GSO projection, the IIB R-R, NS-NS, NS-R and R-NS sectors contain the following massless groundstates (respectively):

$$|0; k\rangle_{-R} \otimes |0; k\rangle_{+R} \quad (2.99)$$

$$\tilde{b}_{-1/2}^I |0; k\rangle_{NS} \otimes b_{-1/2}^J |0; k\rangle_{NS} \quad (2.100)$$

$$\tilde{b}_{-1/2}^I |0; k\rangle_{NS} \otimes |0; k\rangle_{+R} \quad (2.101)$$

$$|0; k\rangle_{-R} \otimes b_{-1/2}^J |0; k\rangle_{NS} \quad (2.102)$$

Since the IIA and IIB theories each contain two Majorana-Weyl gravitinos the theories are 10d $N = 2$ supergravities.

The different sectors have the following field content:

The R-R Sector) The tensor product ('outer product') of two Majorana-Weyl spinors gives rise to bosonic states [10, 11]. In the IIA case these spinors have opposite chirality, giving rise to an eight component vector field, and a three-form

gauge field. k -forms in n -dimensions have their number of independent components given by the binomial coefficient:

$$\binom{n}{k} = \text{Number of independent components of a } k\text{-form in } n\text{-dimensions} \quad (2.103)$$

In this case $k = 3$ and $n = 8$ giving 56 independent components for the three-form gauge field.

The NS-NS Sector) Here there is a tensor product of two eight component vectors. This gives a 64 component rank-2 tensor (an 8×8 matrix) [10, 11]. Such a matrix decomposes into a symmetric matrix and an antisymmetric matrix. The symmetric matrix then further decomposes into a symmetric traceless matrix and a scalar (corresponding to the trace). The scalar is a dilaton and counts as one component. The antisymmetric 8×8 matrix is a 2-form gauge field with $(64 - 8)/2 = 28$ independent components. Finally, the symmetric traceless 8×8 matrix gives a rank-two tensor graviton. Because it is symmetric the 64 components are reduced to $(64 - 8)/2 + 8 = 36$. Then the traceless condition removes one more independent component leaving 35 independent components.

The NS-R Sector) The eight component vector and the Majorana-Weyl fermion tensor to give a spin $3/2$ gravitino with 56 independent components and a spin half dilatino with eight independent components [10, 11].

The R-NS Sector) This sector has the same field content as the NS-R sector. Since the theory is IIA the gravitino of this sector has the opposite chirality to the gravitino in the NS-R sector [10, 11].

IIB Closed String Spectrum

The convention for the IIB string theory is to choose the left and right moving R-sectors to have positive chirality. Using [11]: After GSO projection, the IIB R-R, NS-NS, NS-R and R-NS sectors contain the following massless groundstates (respectively):

$$|0; k\rangle_{+R} \otimes |0; k\rangle_{+R} \quad (2.104)$$

$$\tilde{b}_{-1/2}^I |0; k\rangle_{NS} \otimes b_{-1/2}^J |0; k\rangle_{NS} \quad (2.105)$$

$$\tilde{b}_{-1/2}^I |0; k\rangle_{NS} \otimes |0; k\rangle_{+R} \quad (2.106)$$

$$|0; k\rangle_{+R} \otimes b_{-1/2}^J |0; k\rangle_{+NS} \quad (2.107)$$

The different sectors have the following field content:

The R-R Sector) The tensor product of two Majorana-Weyl spinors gives rise to bosonic states [10, 11]. In the IIB case these spinors have the same chirality, giving rise to a scalar field that contributes one component, an antisymmetric two-form gauge field that has 28 independent components, and, finally, a four-form gauge field with self dual field strength that contributes 35 independent components. Referring to equation 2.103, in this case $k = 4$ and $n = 8$ giving 70 independent components for the four-form gauge field. Self duality then halves this number to 35 [31].

The NS-NS Sector) This sector is the same as the NS-NS sector of type IIA theory.

The NS-R Sector) The eight component vector and the Majorana-Weyl fermion tensor to give a spin 3/2 gravitino with 56 independent components and a spin half dilatino with eight independent components [10, 11].

The R-NS Sector) This sector has the same field content as the NS-R sector. Since the theory is IIB the gravitino of this sector has the same chirality as the gravitino in the NS-R sector [10, 11].

3 Branes in Type IIA and Type IIB String Theories

The gauge fields, charges and field strengths of (1 + 3)d Maxwell theory are briefly reviewed. This is followed by a discussion of the gauge fields, charges and field strengths of branes.

3.1 (1 + 3)d Maxwell Theory

In (1 + 3)d spacetime, Maxwell theory with electric and magnetic point sources gives [11]:

$$dF = \star J_m \tag{3.1}$$

$$d \star F = \star J_e \tag{3.2}$$

Where:

$$J_m = J_{m\mu} dx^\mu \quad J_e = J_{e\mu} dx^\mu \tag{3.3}$$

$J_{m\mu}$ and $J_{e\mu}$ are both functions of current and charge density. Both are one-forms. F is a two-form, which is related to the one-form gauge field A by [11]:

$$F = dA \tag{3.4}$$

$\star F$ is the ‘Hodge dual’ of F . An n -form field strength F on a D -dimensional manifold has a $(D-n)$ -form hodge dual [11]. Therefore, in four spacetime dimensions both F and $\star F$ are two-forms. When considering spacetimes of different dimensions the field strength and its Hodge dual will not always have the same rank.

The electric charge e and the magnetic charge m are related to the field strength by [11]:

$$e = \int_{S^2} \star F \quad g = \int_{S^2} F \tag{3.5}$$

Important Points to Note:

The electric and magnetic charges are point like (zero-dimensional).

In three spatial dimensions a 2d Gaussian surface (usually taken to be a sphere) is required to surround the point-like electric and magnetic charges. As a result, the surfaces that are integrated over are 2d in both the electric and magnetic cases. Correspondingly, the field strength F is a two-form, as is $\star F$.

For an n -form field strength, the corresponding gauge field is an $(n-1)$ -form. In this case the gauge field A is a one-form.

3.2 Gauge Fields and Charges of Branes

In a D -dimensional spacetime, an object with p spatial dimensions (e.g. a p -brane) requires an S^{D-p-2} sphere to surround it [11]. Consider a point on a two-spatial-dimensional surface. This corresponds to a point in a $D = 3$ spacetime. In this case the sphere required to surround the point is S^1 , which is simply a circle on the two-spatial-dimensional surface. Alternatively, consider a point in 4d spacetime (on a three-spatial-dimensional surface), this would require an S^2 to surround it.

Since a p -brane in D spacetime dimensions is enclosed by a sphere given by S^{D-p-2} , the electric charge of the p -brane is given by [11]:

$$e_p = \int_{S^{D-p-2}} \star F \quad (3.6)$$

Where $\star F$ is a $(D - p - 2)$ -form. For an n -form field strength F on a D -dimensional manifold, the hodge dual is a $(D - n)$ -form. This means that for a $(D - p - 2)$ -form hodge dual $(\star F)$:

$$\begin{aligned} D - n &= D - p - 2 \\ \Rightarrow n &= p + 2 \end{aligned} \quad (3.7)$$

The original field strength F is therefore a $p + 2$ -form. It follows that the gauge field is a $p + 1$ -form.

An electrically charged p -brane has a $(p + 1)$ -form gauge field associated with it.

Since F is a $(p + 2)$ -form, the integral for the magnetic charge will be over a sphere S^{p+2} [11].

$$g_p = \int_{S^{p+2}} F \quad (3.8)$$

Since a $(D - p - 2)$ -sphere surrounds a p -brane,

$$D - p - 2 \rightarrow p + 2 \tag{3.9}$$

corresponds to

$$p \rightarrow D - p - 4 \tag{3.10}$$

So the magnetic dual of the p -brane is a $(D - p - 4)$ -brane.

A magnetically charged $(D - p - 4)$ -brane has a $(p + 1)$ -form gauge field associated with it, and is the magnetic dual of the p -brane.

In superstring theory the critical spacetime dimension is $D = 10$. In this case the electrically charged p -brane has a magnetically charged ‘dual’ $(6 - p)$ -brane [11].

3.3 The IIA Theory

The fields in the spectrum of the closed superstrings can have a Dp -brane⁵ associated with them. The dimension of a ‘ Dp -brane’ is the same as for a ‘ p -brane’. In this section the types of electrically charged and magnetically charged Dp -branes associated with each field in the IIA closed string spectrum are reviewed.

3.3.1 The R-R Sector of the IIA Theory

Consider the R-R sector of the type IIA closed string theory. The spectrum gave rise to a one-form and a three-form gauge field [11].

Electrically Charged Dp -branes

An electrically charged Dp -brane has a $(p + 1)$ -gauge field associated with it [11]. Therefore, the one-form gauge field must be associated with an electrically charged D0-brane. Similarly, the three-form gauge field must be associated with an electrically charged D2-brane.

The one-form gauge field is associated with a two-form field strength. The hodge dual of this is an eight-form field strength, associated with a seven-form gauge field. Since an electrically charged Dp -brane has a $(p + 1)$ -form gauge field associated with it, the seven-form is associated with an electrically charge D6-brane [24]. Similarly, the three-form gauge field is associated with a four-form field strength, which is hodge dual to a six-form field strength associated with a five-form gauge field. This five-form gauge field is associated with an electrically charged D4-brane [24].

⁵‘D’ just stands for ‘Dirichlet’, as opposed to some constant value like the number of spacetime dimensions.

Magnetically Charged $D(D - p - 4)$ -branes

Above it was explained that the magnetically charged $D(D - p - 4)$ -brane (in $(1 + 9)$ d this is a $D(6 - p)$ -brane) has a $(p + 1)$ -gauge field associated with it, and that such a brane is the magnetic dual of the p -brane. Therefore, the one-form gauge field must be associated with a magnetically charged D6-brane [11]. This D6-brane is the magnetic dual of the electrically charged D0-brane. Similarly, a three-form gauge field must be associated with a magnetically charged D4-brane. This D4-brane is the magnetic dual of the electrically charged D2-brane.

The one-form gauge field is associated with a two-form field strength. The hodge dual of this is an eight-form field strength, associated with a seven-form gauge field. Since a magnetically charged $D(D - p - 4)$ -brane has a $(p + 1)$ -form gauge field associated with it, the seven-form is associated with a magnetically charge D0-brane [24]. Similarly, the three-form gauge field is associated with a four-form field strength, which is hodge dual to a six-form field strength associated with a five-form gauge field. This five-form gauge field is associated with a magnetically charged D2-brane [24].

The D8-brane

Given that IIA theory seems to only include branes of even spatial dimensions, a D8-brane can also be considered [11]. Electrically, such a brane would be associated with a nine-form gauge field and a ten-form field strength, which is not dynamical, and so does not arise in the physical spectrum. However, such a brane is considered in some special cases.

Summary of the R-R sector of the IIA Theory:

Associated with the one-form gauge field in the R-R sector of the IIA string theory is an electrically charged D0-brane, and its dual magnetically charged D6-brane.

Associated with the three-form gauge field in the R-R sector of the IIA string theory is an electrically charged D2-brane, and its dual magnetically charged D4-brane.

Associated with the five-form gauge field in the R-R sector of the IIA string theory is an electrically charged D4-brane, and its dual magnetically charged D2-brane.

Associated with the seven-form gauge field in the R-R sector of the IIA string theory is an electrically charged D6-brane, and its dual magnetically charged D0-brane.

There is also a D8-brane, which electrically couples to a nine-form gauge field.

3.3.2 The NS-NS Sector of the IIA Theory

Consider the NS-NS sector of the type IIA closed string theory [24]. This contains a rank three field strength associated with a two-form field. This two-form field is associated with an electrically charged 1-brane and a magnetically charged 5-brane. The hodge dual of the rank three field strength is a rank seven field strength associated with a six-form field. This six-form field is associated with an electrically charged 5-brane and a magnetically charged 1-brane. The 1-brane is identified as an ‘F1-brane’ (the ‘fundamental string’) and the 5-brane is identified as an ‘NS5-brane’ (Sometimes called a ‘solitonic 5-brane’. The F1-brane is indistinguishable from the very strings that the spectrum arose from. It should be distinguished from the D1-brane. Both the F1-brane and the NS5-brane behave like semi-classical solitons, and are comparable to ’t Hooft-Polyakov magnetic monopoles [32].

Summary of the NS-NS sector of the IIA Theory:

Associated with the two-form gauge field in the NS-NS sector of the IIA string theory is an electrically charged F1-brane, and its dual magnetically charged NS5-brane.

Associated with the six-form gauge field in the NS-NS sector of the IIA string theory is an electrically charged NS5-brane, and its dual magnetically charged F1-brane.

3.4 The IIB Theory

In this section the types of electrically charged and magnetically charged Dp -branes associated with each field in the IIB closed string spectrum are reviewed.

3.4.1 The R-R Sector of the IIB Theory

Consider the R-R sector of the type IIB closed string theory. The spectrum gave rise to a zero-form, a two-form and a four-form gauge field [11].

Electrically Charged Dp -branes

Since an electrically charged Dp -brane has a $(p + 1)$ -gauge field associated with it, the zero-form gauge field must be associated with an electrically charged $D(-1)$ -brane. A Dp -brane has p spatial dimensions. When embedded in a spacetime, these branes also have a time dimension. Including this time dimension means the brane is described by a $(1 + p)$ dimensional worldvolume. Therefore, $p = -1$ corresponds to a brane with

zero *spacetime* dimensions. It has a zero dimensional worldvolume, and corresponds to a single point (a single instant) in spacetime - it is an instanton [11, 29]. The two-form gauge field must be associated with an electrically charged D1-brane (D-string). The four-form gauge field must be associated with an electrically charged D3-brane.

The zero-form gauge field is associated with a one-form field strength. The hodge dual of this is a nine-form field strength, associated with an eight-form gauge field. Since an electrically charged Dp -brane has a $(p + 1)$ -form gauge field associated with it, the eight-form is associated with an electrically charge D7-brane [24]. Similarly, the two-form gauge field is associated with a three-form field strength, which is hodge dual to a seven-form field strength associated with a six-form gauge field. This six-form gauge field is associated with an electrically charged D5-brane. Lastly, the four-form gauge field is associated with a five-form field strength, which is self-dual [24].

Magnetically Charged $D(D - p - 4)$ -branes

The magnetically charged $D(D - p - 4)$ -brane (in 10d this is a $D(6 - p)$ -brane) has a $(p + 1)$ -gauge field associated with it. Such a brane is the magnetic dual of the p -brane. Therefore, a zero-form gauge field must be associated with a magnetically charged D7-brane [11]. This D7-brane is the magnetic dual of the electrically charged $D(-1)$ -brane. A two-form gauge field must be associated with a magnetically charged D5-brane. This D5-brane is the magnetic dual of the electrically charged D1-brane. A four-form gauge field must be associated with a magnetically charged D3-brane. This D3-brane is the magnetic dual of itself.

The zero-form gauge field is associated with a one-form field strength. The hodge dual of this is a nine-form field strength, associated with a eight-form gauge field. Since a magnetically charged $D(D - p - 4)$ -brane has a $(p + 1)$ -form gauge field associated with it, the eight-form is associated with a magnetically charge $D(-1)$ -brane [24]. Similarly, the two-form gauge field is associated with a three-form field strength, which is hodge dual to a seven-form field strength associated with a six-form gauge field. This six-form gauge field is associated with a magnetically charged D1-brane [24]. Lastly, the four-form gauge field is associated with a five-form field strength, which is self dual. This gives rise to a four-form gauge field strength, associated with a magnetically charged D3-brane. [24].

The D9-brane

Given that IIB theory seems to only include branes of odd spatial dimension, a D9-brane might be considered. Electrically, such a brane would be associated with a ten-form gauge field and a 11-form field strength [11]. Such branes can be used in special circumstances.

Summary of the R-R sector of the IIB Theory:

Associated with the zero-form gauge field in the R-R sector of the IIA string theory is an electrically charged $D(-1)$ -brane (instanton), and its dual magnetically charged D7-brane.

Associated with the two-form gauge field in the R-R sector of the IIA string theory is an electrically charged D1-brane, and its dual magnetically charged D5-brane.

Associated with the four-form gauge field in the R-R sector of the IIA string theory is an electrically and magnetically charged, self-dual, D3-brane.

Associated with the six-form gauge field in the R-R sector of the IIA string theory is a electrically charged D5-brane, and its dual magnetically charged D1-brane.

Associated with the eight-form gauge field in the R-R sector of the IIA string theory is a electrically charged D7-brane, and its dual magnetically charged $D(-1)$ -brane.

There is also a D9-brane, which electrically couples to a 10-form gauge field.

3.4.2 The NS-NS Sector of the IIB Theory

Consider the NS-NS sector of the type IIB closed string theory [24]. This contains a rank three field strength associated with a a two-form field. Taking the hodge dual of the field strength gives a rank seven field strength associated with a six-form gauge field. Subsequently, the branes, and the fields that they are coupled to, are exactly as in section 3.3.2.

Summary of the NS-NS sector of the IIB Theory:

Associated with the two-form gauge field in the NS-NS sector of the IIB string theory is an electrically charged F1-brane, and its dual magnetically charged NS5-brane.

Associated with the six-form gauge field in the NS-NS sector of the IIB string theory is an electrically charged NS5-brane, and its dual magnetically charged F1-brane.

4 3d Effective Field Theory

4.1 From 3d $N = 4$ (Eight Supercharge) Field Theory to 3d $N = 2$ (Four Supercharge) Field Theory

It will be useful, to discuss the relevant 3d field theory. Then, when the brane configurations are discussed in section 6, this section will provide some context for the field theory results that arise. Superfields are used in this section; see Appendix B for the conventions that are adopted.

Consider a 3d $N = 4$ theory. The 3d $N = 4$ on-shell vector multiplet consists of a 3d vector field, three real scalars and four majorana fermions. The 3d $N = 4$ on-shell hypermultiplet consists of four real scalars and four Majorana fermions. A 3d $N = 4$ vector multiplet contains a 3d $N = 2$ vector multiplet V and a 3d $N = 2$ (adjoint) chiral multiplet Φ . The $N = 4$ hypermultiplet, can also be written as an $N = 2$ chiral and anti-chiral superfield Q and \tilde{Q} , respectively. The on-shell 3d $N = 2$ vector multiplet V contains a vector field a_μ , a real scalar field and a Dirac fermion. The on-shell 3d $N = 2$ chiral multiplet Q contains two real scalar fields and two Majorana fermions. There is also another type of $N = 4$ supermultiplet called a linear multiplet, which contains the 3d $N = 2$ linear multiplet Σ [4, 33]:

$$\Sigma = \frac{i}{4} \bar{D}^\alpha D_\alpha V \quad (4.1)$$

The superfields expressions that were used are written explicitly in Appendix B. The 3d $N = 4$ action can be written in terms of the 3d $N = 2$ superfields. The $N = 4$ Lagrangian contains kinetic terms [4, 33, 34]:

$$L_{kin} = \int d^2\theta d^2\bar{\theta} \left(Q^\dagger e^{qV+2im\theta\bar{\theta}} Q + \tilde{Q}^\dagger e^{-qV+2i\bar{m}\theta\bar{\theta}} \tilde{Q} \right) + \left[\int d^2\theta \sqrt{2} \Phi Q \tilde{Q} + c.c. \right] \\ + \left[\int d^2\theta m_c Q \tilde{Q} + c.c. \right] \quad (4.2)$$

Here m is the real mass arising from the background vector multiplet [35]. The superpotential is turned off in this case, but this would usually contribute a complex mass term corresponding to the scalar of the background chiral multiplet.

There is a linear multiplet Lagrangian term:

$$- \frac{1}{2e^2} \int d^2\theta d^2\bar{\theta} \Sigma^2 \quad (4.3)$$

Fayet-Iliopoulos terms are contained in Lagrangian terms [4, 33]:

$$-\frac{\zeta}{4\pi} \int d^2\theta d^2\bar{\theta} V - \frac{\zeta_\Phi}{4\pi} \int d^2\theta \Phi \quad (4.4)$$

The abelian Chern-Simons terms are contained in [4, 33]:

$$-\frac{k}{4\pi} \int d^2\theta d^2\bar{\theta} \Sigma V \quad (4.5)$$

Whereas the non-abelian CS-terms are contained in [33]:

$$i \frac{k}{8\pi} \int d^2\theta d^2\bar{\theta} \int_0^1 dt \text{Tr}\{V \bar{D}^\alpha (e^{tV} D_\alpha e^{-tV})\} \quad (4.6)$$

A mass term can be introduced for the 3d $N = 2$ adjoint chiral multiplet Φ of the form:

$$\int d^2\theta \mu \Phi^2 \quad (4.7)$$

A mass $\mu \neq 0$ breaks SUSY from $N = 4$ to $N = 2$. This because the 3d $N = 4$ vector multiplet is formed of V and Φ and, in order for $N = 4$ SUSY to apply, V and Φ must both have the same mass. The low energy theory is typically considered. In this limit the Φ fields are integrated out, and the remaining action does not contain Φ terms.

4.2 3d $N = 2$ $U(1)$ Theory with One Flavour of Matter and Without Antimatter

In the results section, a variety of $(1+2)$ d low energy field theories are obtained. As a result it is important to know exactly how to write the most relevant terms that appear in the action. This section, and the following few sections, will explain what sort of terms appear in the actions of both abelian and non-abelian $(1+2)$ d field theories, with one or more flavour. Consider, first, a 3d $N = 2$ $U(1)$ matter theory, with a single massive matter flavour. For simplicity, consider only matter and neglect antimatter for now. Such a theory contains the following Lagrangian terms [33, 34]:

$$\begin{aligned} & \int d^2\theta d^2\bar{\theta} Q^\dagger e^{qV+2im\theta\bar{\theta}} Q \\ & - \frac{1}{e^2} \int d^2\theta d^2\bar{\theta} \Sigma^2 \\ & - \frac{\zeta}{2\pi} \int d^2\theta d^2\bar{\theta} V \\ & - \frac{k}{4\pi} \int d^2\theta d^2\bar{\theta} \Sigma V \end{aligned} \quad (4.8)$$

Much can be ascertained by analysing the scalars in the field theory. The superfields of the above terms can be expanded out into their constituent fields. The resulting terms which contain scalar fields and which do not contain derivatives form the classical scalar potential. These are given by [34]:

$$V_c = -\frac{1}{2e^2}D^2 + (m + q\sigma)^2 |\phi|^2 + qD|\phi|^2 - |F|^2 - \frac{\zeta}{4\pi}D - \frac{k}{4\pi}\sigma D \quad (4.9)$$

The first term comes from the second term in 4.8, the second, third and fourth terms come from the first term in 4.8, the fifth term comes from the third term in 4.8 and the sixth term comes from the fourth term in 4.8. σ and D are scalars belonging to the 3d $N = 2$ vector multiplet V , ϕ comes from the 3d $N = 2$ chiral multiplet Q and $\bar{\phi}$ comes from Q^\dagger , giving $\phi^2 = \phi\bar{\phi}$. F is contained in Q and \bar{F} is contained in Q^\dagger , giving $F^2 = F\bar{F}$.

The F-term equation of motion is:

$$F = 0 \quad (4.10)$$

The D-term equation of motion is:

$$D = \frac{e^2}{4\pi} (4\pi q|\phi|^2 - \zeta - k\sigma) \quad (4.11)$$

This can be seen by taking the derivative of 4.9 with respect to F and D respectively, then setting the result to zero. Plugging these equations for F and D back into 4.9 gives [34]:

$$\begin{aligned} V_c &= -\frac{1}{2e^2} \frac{e^4}{16\pi^2} (4\pi q|\phi|^2 - \zeta - k\sigma)^2 + D \left(q|\phi|^2 - \frac{\zeta}{4\pi} - \frac{k}{4\pi}\sigma \right) + (m + q\sigma)^2 |\phi|^2 \\ &= -\frac{e^2}{32\pi^2} (4\pi q|\phi|^2 - \zeta - k\sigma)^2 + \frac{e^2}{4\pi} (4\pi q|\phi|^2 - \zeta - k\sigma) \left(q|\phi|^2 - \frac{\zeta}{4\pi} - \frac{k}{4\pi}\sigma \right) \\ &\quad + (m + q\sigma)^2 |\phi|^2 \\ &= -\frac{e^2}{32\pi^2} (4\pi q|\phi|^2 - \zeta - k\sigma)^2 + \frac{e^2}{16\pi^2} (4\pi q|\phi|^2 - \zeta - k\sigma) (4\pi q|\phi|^2 - \zeta - k\sigma) \\ &\quad + (m + q\sigma)^2 |\phi|^2 \\ &= -\frac{e^2}{32\pi^2} (4\pi q|\phi|^2 - \zeta - k\sigma)^2 + \frac{e^2}{16\pi^2} (4\pi q|\phi|^2 - \zeta - k\sigma)^2 + (m + q\sigma)^2 |\phi|^2 \\ &= \frac{e^2}{32\pi^2} (4\pi q|\phi|^2 - \zeta - k\sigma)^2 + (m + q\sigma)^2 |\phi|^2 \end{aligned} \quad (4.12)$$

An effective action can be obtained by integrating out the massive fields from the theory. For a massive matter superfield Q , all of its constituent fields would be integrated out to obtain the effective action. These include a complex scalar ϕ , a $(1+2)d$ two complex component Dirac spinor, and a complex auxiliary scalar F (see Appendix B). As discussed in section 5, integrating out the massive fermions ψ gives contributions to the low energy values of k and ζ . Relabelling the adjusted k and ζ as k_{eff} and ζ_{eff} gives the effective semiclassical potential [34]:

$$V_{sc} = \frac{e^2}{32\pi^2} (4\pi q|\phi|^2 - \zeta_{eff} - k_{eff}\sigma)^2 + (m + q\sigma)^2 |\phi|^2 \quad (4.13)$$

Here ϕ is the renormalised field, containing a renormalisation factor [34]. The effective mass of ϕ is now given by $(m + q\sigma) \equiv m(\sigma)$. ζ_{eff} and k_{eff} are the effective Chern-Simons and Fayet-Iliopoulos terms, obtained from integrating out the massive matter ϕ .

The effective Chern-Simons term is given by:

$$k_{eff} = k + \frac{1}{2}q^2 \text{sign}(m(\sigma)) \quad (4.14)$$

Whilst the effective Fayet-Iliopoulos term is given by:

$$\zeta_{eff} = \zeta + \frac{1}{2}qm \text{sign}(m(\sigma)) \quad (4.15)$$

The effective Chern-Simons term is of central importance to this text, and is discussed in section 5.

Minimising the potential gives the equations:

$$4\pi q|\phi|^2 = \zeta_{eff} + k_{eff}\sigma \quad (4.16)$$

$$m(\sigma)\phi = (m + q\sigma)\phi = 0 \quad (4.17)$$

4.3 3d $N = 2$ $U(1)$ Theory with One Flavour of Matter and Antimatter

Consider adding the antimatter term to the action:

$$\int d^2\theta d^2\bar{\theta} \tilde{Q}^\dagger e^{-qV + 2i\tilde{m}\theta\bar{\theta}} \tilde{Q} \quad (4.18)$$

Expanding the superfields contributes the additional terms:

$$(\tilde{m} - q\sigma)^2 |\tilde{\phi}|^2 - qD|\tilde{\phi}|^2 - |\tilde{F}|^2 \quad (4.19)$$

The classical scalar potential then becomes:

$$\begin{aligned} V_c = & -\frac{1}{2e^2}D^2 + (m + q\sigma)^2 |\phi|^2 + (\tilde{m} - q\sigma)^2 |\tilde{\phi}|^2 + qD|\phi|^2 - qD|\tilde{\phi}|^2 - |F|^2 - |\tilde{F}|^2 \\ & - \frac{\zeta_V}{4\pi}D - \frac{k}{4\pi}\sigma D \end{aligned} \quad (4.20)$$

The F-term and D-term equations of motion become [34]:

$$F = \tilde{F} = 0 \quad (4.21)$$

$$D = e^2 \left(q|\phi|^2 - q|\tilde{\phi}|^2 - \frac{\zeta}{4\pi} - \frac{k}{4\pi}\sigma \right) \quad (4.22)$$

Plugging these back into equation 4.20 gives:

$$\begin{aligned} V_c = & -\frac{1}{2e^2}e^4 \left(q|\phi|^2 - q|\tilde{\phi}|^2 - \frac{\zeta}{4\pi} - \frac{k}{4\pi}\sigma \right)^2 + (m + q\sigma)^2 |\phi|^2 + (\tilde{m} - q\sigma)^2 |\tilde{\phi}|^2 \\ & + D \left(q|\phi|^2 - q|\tilde{\phi}|^2 - \frac{\zeta}{4\pi} - \frac{k}{4\pi}\sigma \right) \\ = & -\frac{1}{2e^2}e^4 \left(q|\phi|^2 - q|\tilde{\phi}|^2 - \frac{\zeta}{4\pi} - \frac{k}{4\pi}\sigma \right)^2 + (m + q\sigma)^2 |\phi|^2 + (\tilde{m} - q\sigma)^2 |\tilde{\phi}|^2 \\ & + e^2 \left(q|\phi|^2 - q|\tilde{\phi}|^2 - \frac{\zeta}{4\pi} - \frac{k}{4\pi}\sigma \right) \left(q|\phi|^2 - q|\tilde{\phi}|^2 - \frac{\zeta}{4\pi} - \frac{k}{4\pi}\sigma \right) \\ = & -\frac{1}{2e^2} \frac{e^4}{16\pi^2} \left(4\pi q|\phi|^2 - 4\pi q|\tilde{\phi}|^2 - \zeta - k\sigma \right)^2 + (m + q\sigma)^2 |\phi|^2 + (\tilde{m} - q\sigma)^2 |\tilde{\phi}|^2 \\ & + \frac{e^2}{16\pi^2} \left(4\pi q|\phi|^2 - 4\pi q|\tilde{\phi}|^2 - \zeta - k\sigma \right) \left(4\pi q|\phi|^2 - 4\pi q|\tilde{\phi}|^2 - \zeta - k\sigma \right) \\ = & -\frac{e^2}{32\pi^2} \left(4\pi q|\phi|^2 - 4\pi q|\tilde{\phi}|^2 - \zeta - k\sigma \right)^2 + (m + q\sigma)^2 |\phi|^2 + (\tilde{m} - q\sigma)^2 |\tilde{\phi}|^2 \\ & + \frac{e^2}{16\pi^2} \left(4\pi q|\phi|^2 - 4\pi q|\tilde{\phi}|^2 - \zeta - k\sigma \right)^2 \\ = & \frac{e^2}{32\pi^2} \left(4\pi q|\phi|^2 - 4\pi q|\tilde{\phi}|^2 - \zeta - k\sigma \right)^2 + (m + q\sigma)^2 |\phi|^2 + (\tilde{m} - q\sigma)^2 |\tilde{\phi}|^2 \end{aligned} \quad (4.23)$$

The effective semiclassical action then becomes:

$$V_{sc} = \frac{e^2}{32\pi^2} \left(4\pi q |\phi|^2 - 4\pi q |\tilde{\phi}|^2 - \zeta_{\text{eff}} - k_{\text{eff}} \sigma \right)^2 + (m + q\sigma)^2 |\phi|^2 + (\tilde{m} - q\sigma)^2 |\tilde{\phi}|^2 \quad (4.24)$$

where ϕ and $\tilde{\phi}$ contain renormalisation factors. The equations that minimise this potential are:

$$4\pi q |\phi|^2 - 4\pi q |\tilde{\phi}|^2 - \zeta_{\text{eff}} - k_{\text{eff}} \sigma = 0 \quad (4.25)$$

$$(m + q\sigma) \phi = 0 \quad (4.26)$$

$$(\tilde{m} - q\sigma) \tilde{\phi} = 0 \quad (4.27)$$

4.4 3d $N = 2$ $U(1)$ Theory with N_f Flavours of Matter and Antimatter

It is easy to introduce more than one flavour of matter. Consider N_f flavours labelled $i = 1, \dots, N_f$. This corresponds to N_f chiral multiplets Q_i and \tilde{Q}_i . The Lagrangian density matter and antimatter terms are written [34]:

$$\int d^2\theta d^2\bar{\theta} \sum_{i=1}^{N_f} \left(Q_i^\dagger e^{q_i V + 2im_i \theta\bar{\theta}} Q_i \right) + \int d^2\theta d^2\bar{\theta} \sum_{i=1}^{N_f} \left(\tilde{Q}_i^\dagger e^{-q_i V + 2i\tilde{m}_i \theta\bar{\theta}} \tilde{Q}_i \right) \quad (4.28)$$

The classical scalar potential is the straightforward generalisation [34]:

$$\begin{aligned} V_c = & -\frac{1}{2e^2} D^2 + \sum_{i=1}^{N_f} (m_i + q_i \sigma)^2 |\phi_i|^2 + \sum_{i=1}^{N_f} (\tilde{m}_i - q_i \sigma)^2 |\tilde{\phi}_i|^2 \\ & + \sum_{i=1}^{N_f} q_i D |\phi_i|^2 - \sum_{i=1}^{N_f} q_i D |\tilde{\phi}_i|^2 - |F_i|^2 - |\tilde{F}_i|^2 - \frac{\zeta_V}{4\pi} D - \frac{k}{4\pi} \sigma D \end{aligned} \quad (4.29)$$

This gives the F-term and D-term equations of motion [34]:

$$F_i = \tilde{F}_i = 0 \quad (4.30)$$

$$D = e^2 \left(\sum_{i=1}^{N_f} q_i |\phi_i|^2 - \sum_{i=1}^{N_f} q_i |\tilde{\phi}_i|^2 - \frac{\zeta}{4\pi} - \frac{k}{4\pi} \sigma \right) \quad (4.31)$$

Plugging these into equation 4.29 gives:

$$\begin{aligned}
V_c &= -\frac{1}{2e^2} e^4 \left(\sum_{i=1}^{N_f} q_i |\phi_i|^2 - \sum_{i=1}^{N_f} q_i |\tilde{\phi}_i|^2 - \frac{\zeta}{4\pi} - \frac{k}{4\pi} \sigma \right)^2 + \sum_{i=1}^{N_f} (m_i + q_i \sigma)^2 |\phi_i|^2 \\
&\quad + \sum_{i=1}^{N_f} (\tilde{m}_i - q_i \sigma)^2 |\tilde{\phi}_i|^2 + \sum_{i=1}^{N_f} q_i D |\phi_i|^2 - \sum_{i=1}^{N_f} q_i D |\tilde{\phi}_i|^2 - \frac{\zeta_V}{4\pi} D - \frac{k}{4\pi} \sigma D \\
&= -\frac{1}{2e^2} e^4 \left(\sum_{i=1}^{N_f} q_i |\phi_i|^2 - \sum_{i=1}^{N_f} q_i |\tilde{\phi}_i|^2 - \frac{\zeta}{4\pi} - \frac{k}{4\pi} \sigma \right)^2 + \sum_{i=1}^{N_f} (m_i + q_i \sigma)^2 |\phi_i|^2 \\
&\quad + \sum_{i=1}^{N_f} (\tilde{m}_i - q_i \sigma)^2 |\tilde{\phi}_i|^2 + D \left(\sum_{i=1}^{N_f} q_i |\phi_i|^2 - \sum_{i=1}^{N_f} q_i |\tilde{\phi}_i|^2 - \frac{\zeta_V}{4\pi} - \frac{k}{4\pi} \sigma \right) \\
&= -\frac{e^2}{2} \left(\sum_{i=1}^{N_f} q_i |\phi_i|^2 - \sum_{i=1}^{N_f} q_i |\tilde{\phi}_i|^2 - \frac{\zeta}{4\pi} - \frac{k}{4\pi} \sigma \right)^2 + \sum_{i=1}^{N_f} (m_i + q_i \sigma)^2 |\phi_i|^2 \\
&\quad + \sum_{i=1}^{N_f} (\tilde{m}_i - q_i \sigma)^2 |\tilde{\phi}_i|^2 + e^2 \left(\sum_{i=1}^{N_f} q_i |\phi_i|^2 - \sum_{i=1}^{N_f} q_i |\tilde{\phi}_i|^2 - \frac{\zeta_V}{4\pi} - \frac{k}{4\pi} \sigma \right)^2 \\
&= \frac{e^2}{2} \left(\sum_{i=1}^{N_f} q_i |\phi_i|^2 - \sum_{i=1}^{N_f} q_i |\tilde{\phi}_i|^2 - \frac{\zeta}{4\pi} - \frac{k}{4\pi} \sigma \right)^2 + \sum_{i=1}^{N_f} (m_i + q_i \sigma)^2 |\phi_i|^2 \\
&\quad + \sum_{i=1}^{N_f} (\tilde{m}_i - q_i \sigma)^2 |\tilde{\phi}_i|^2 \\
&= \frac{e^2}{32\pi^2} \left(4\pi \sum_{i=1}^{N_f} q_i |\phi_i|^2 - 4\pi \sum_{i=1}^{N_f} q_i |\tilde{\phi}_i|^2 - \zeta - k\sigma \right)^2 + \sum_{i=1}^{N_f} (m_i + q_i \sigma)^2 |\phi_i|^2 \\
&\quad + \sum_{i=1}^{N_f} (\tilde{m}_i - q_i \sigma)^2 |\tilde{\phi}_i|^2
\end{aligned} \tag{4.32}$$

The effective semiclassical potential is then:

$$\begin{aligned}
V_{\text{sc}} &= \frac{e^2}{32\pi^2} \left(4\pi \sum_{i=1}^{N_f} q_i |\phi_i|^2 - 4\pi \sum_{i=1}^{N_f} q_i |\tilde{\phi}_i|^2 - \zeta_{\text{eff}} - k_{\text{eff}} \sigma \right)^2 + \sum_{i=1}^{N_f} (m_i + q_i \sigma)^2 |\phi_i|^2 \\
&\quad + \sum_{i=1}^{N_f} (\tilde{m}_i - q_i \sigma)^2 |\tilde{\phi}_i|^2
\end{aligned} \tag{4.33}$$

Where ϕ and $\tilde{\phi}$ contain renormalisation factors. The equations that minimise the potential are:

$$4\pi \sum_{i=1}^{N_f} q_i |\phi_i|^2 - 4\pi \sum_{i=1}^{N_f} q_i |\tilde{\phi}_i|^2 - \zeta_{\text{eff}} - k_{\text{eff}} \sigma = 0 \quad (4.34)$$

$$(m_i + q_i \sigma) \phi_i = 0 \quad (4.35)$$

$$(\tilde{m}_i - q_i \sigma) \tilde{\phi}_i = 0 \quad (4.36)$$

4.5 3d $N = 2$ $U(N_c)$ Theory with N_f Flavours of Matter and Antimatter

In order to introduce a non-abelian gauge symmetry the superfield Lagrangian density term:

$$- \frac{k}{4\pi} \int d^2\theta d^2\bar{\theta} \Sigma V \quad (4.37)$$

is replaced with [33]:

$$+ i \frac{k}{8\pi} \int d^2\theta d^2\bar{\theta} \int_0^1 dt \text{Tr} \{ V \bar{D}^\alpha (e^{tV} D_\alpha e^{-tV}) \} \quad (4.38)$$

Where the vector multiplet is given by $V_{j'}^j = V^a (T_a)_{j'}^j$ ($a = 1, \dots, N_c^2$). The trace is always over the colour indices ($j, j', j'' = 1, \dots, N_c$). This term contributes a factor of [33]:

$$- \frac{k}{4\pi} \text{Tr} (\sigma D) \quad (4.39)$$

where $\sigma_{j''}^{j'} := \sigma^a (T_a)_{j''}^{j'}$ and $D_{j'}^j := D^a (T_a)_{j'}^j$. Also included are the terms [34, 36, 37]:

$$\begin{aligned} & \int d^2\theta d^2\bar{\theta} \sum_{i=1}^{N_f} Q_{i,j'}^\dagger \left(e^{q_i V + 2im_i \theta \bar{\theta}} \right)_j^{j'} Q_i^j \\ & + \int d^2\theta d^2\bar{\theta} \sum_{i=1}^{N_f} \tilde{Q}_{i,j'}^\dagger \left(e^{-q_i V + 2i\tilde{m}_i \theta \bar{\theta}} \right)_j^{j'} \tilde{Q}_i^j \end{aligned} \quad (4.40)$$

where:

$$\begin{aligned}
\left(e^{q_i V + 2im_i \theta \bar{\theta}}\right)_j^{j'} &:= 1 + \left(q_i V_j^{j'} + \delta_j^{j'} 2im_i \theta \bar{\theta}\right) \\
&+ \frac{1}{2} \left(q_i V_{j''}^{j'} + \delta_{j''}^{j'} 2im_i \theta \bar{\theta}\right) \left(q_i V_j^{j''} + \delta_j^{j''} 2im_i \theta \bar{\theta}\right)
\end{aligned} \tag{4.41}$$

and:

$$\begin{aligned}
\left(e^{-q_i V + 2im_i \theta \bar{\theta}}\right)_j^{j'} &:= 1 + \left(-q_i V_j^{j'} + \delta_j^{j'} 2im_i \theta \bar{\theta}\right) \\
&+ \frac{1}{2} \left(-q_i V_{j''}^{j'} + \delta_{j''}^{j'} 2im_i \theta \bar{\theta}\right) \left(-q_i V_j^{j''} + \delta_j^{j''} 2im_i \theta \bar{\theta}\right)
\end{aligned} \tag{4.42}$$

and where the trace is taken for the colour indices $j, j', j'' = 1, \dots, N_c$. The exponential expansion takes a similar form to B.11. Additionally, there are the terms [34]:

$$\begin{aligned}
&\int d^2\theta m_c \sum_{i=1}^{N_f} Q_{i,j} \tilde{Q}^{i,j} + c.c. \\
&- \frac{1}{2e^2} \int d^2\theta d^2\bar{\theta} \text{Tr}(\Sigma^2) \\
&- \frac{\zeta_V}{4\pi} \int d^2\theta d^2\bar{\theta} \text{Tr}(V)
\end{aligned} \tag{4.43}$$

The classical scalar potential is given as:

$$\begin{aligned}
V_c = & -\frac{1}{2e^2} \text{Tr}(D^2) + \sum_{i=1}^{N_f} \bar{\phi}_i (m_i + q_i \sigma)^2 \phi_i + \sum_{i=1}^{N_f} \bar{\tilde{\phi}}_i (\tilde{m}_i - q_i \sigma)^2 \tilde{\phi}_i \\
& + \sum_{i=1}^{N_f} q_i \bar{\phi}_i D \phi_i - \sum_{i=1}^{N_f} q_i \bar{\tilde{\phi}}_i D \tilde{\phi}_i - |F_i|^2 - |\tilde{F}_i|^2 - \frac{\zeta_V}{4\pi} \text{Tr}(D) - \frac{k}{4\pi} \text{Tr}(\sigma D)
\end{aligned} \tag{4.44}$$

Indicating the colour indices ($j, j', j'' = 1, \dots, N_c$) explicitly, using summation convention for the flavour indices ($i, i', i'' = 1, \dots, N_f$), and using the convention $q_i = +1$ for all i , this is written:

$$\begin{aligned}
V_c = & -\frac{1}{2e^2} \text{Tr}(D^2) + \bar{\phi}_{i'',j''} \left(\delta_{j'}^{j''} m_{i'}^{i''} + \sigma_{j'}^{j''} \delta_{i'}^{i''}\right) \left(\delta_j^{j'} m_i^{i'} + \sigma_j^{j'} \delta_i^{i'}\right) \phi^{i,j} \\
& + \bar{\tilde{\phi}}_{i'',j''} \left(\delta_{j'}^{j''} \tilde{m}_{i'}^{i''} - \sigma_{j'}^{j''} \delta_{i'}^{i''}\right) \left(\delta_j^{j'} \tilde{m}_i^{i'} - \sigma_j^{j'} \delta_i^{i'}\right) \tilde{\phi}^{i,j} + \bar{\phi}_{i,j'} D_j^{j'} \phi^{i,j} \\
& - \bar{\tilde{\phi}}_{i,j'} D_j^{j'} \tilde{\phi}^{i,j} - |\bar{F}_{i,j} F^{i,j}| - |\bar{\tilde{F}}_{i,j} \tilde{F}^{i,j}| - \frac{\zeta_V}{4\pi} \text{Tr}(D) - \frac{k}{4\pi} \text{Tr}(\sigma D)
\end{aligned} \tag{4.45}$$

where $m_i^{i'}$ and $\tilde{m}_i^{i'}$ are diagonal matrices (only non-zero for $i = i'$) and $\sigma_j^{j'}$ is diagonal via gauge rotation (only non-zero for $j = j'$) [34]. Note that all indices contract. The F-term and D-term equations of motion are:

$$F^{i,j} = \tilde{F}^{i,j} = 0 \quad (4.46)$$

$$D_{j'}^j = e^2 \left(\bar{\phi}_{i,j'} \phi^{i,j} - \bar{\phi}_{i,j'} \tilde{\phi}^{i,j} - \frac{\zeta_V}{4\pi} \delta_{j'}^j - \frac{k}{4\pi} \sigma_{j'}^j \right) \quad (4.47)$$

Which give:

$$\begin{aligned} V_c = & \frac{e^2}{32\pi^2} \left(4\pi \bar{\phi}_{i,j} \phi^{i,j'} - 4\pi \bar{\phi}_{i,j} \tilde{\phi}^{i,j'} - \zeta_V \delta_j^{j'} - k \sigma_j^{j'} \right) \\ & \times \left(4\pi \bar{\phi}_{i,j'} \phi^{i,j} - 4\pi \bar{\phi}_{i,j'} \tilde{\phi}^{i,j} - \zeta_V \delta_{j'}^j - k \sigma_{j'}^j \right) \\ & + \bar{\phi}_{i'',j''} \left(\delta_{j'}^{j''} m_{i'}^{i''} + \sigma_{j'}^{j''} \delta_{i'}^{i''} \right) \left(\delta_j^{j'} m_i^{i'} + \sigma_j^{j'} \delta_i^{i'} \right) \phi^{i,j} \\ & + \bar{\phi}_{i'',j''} \left(\delta_{j'}^{j''} \tilde{m}_{i'}^{i''} - \sigma_{j'}^{j''} \delta_{i'}^{i''} \right) \left(\delta_j^{j'} \tilde{m}_i^{i'} - \sigma_j^{j'} \delta_i^{i'} \right) \tilde{\phi}^{i,j} \end{aligned} \quad (4.48)$$

after a relabelling of the colour indices. The effective semiclassical action then becomes:

$$\begin{aligned} V_{sc} = & \frac{e^2}{32\pi^2} \left(4\pi \bar{\phi}_{i,j} \phi^{i,j'} - 4\pi \bar{\phi}_{i,j} \tilde{\phi}^{i,j'} - \zeta_{\text{eff}} \delta_j^{j'} - k_{\text{eff}} \sigma_j^{j'} \right) \\ & \times \left(4\pi \bar{\phi}_{i,j'} \phi^{i,j} - 4\pi \bar{\phi}_{i,j'} \tilde{\phi}^{i,j} - \zeta_{\text{eff}} \delta_{j'}^j - k_{\text{eff}} \sigma_{j'}^j \right) \\ & + \bar{\phi}_{i'',j''} \left(\delta_{j'}^{j''} m_{i'}^{i''} + \sigma_{j'}^{j''} \delta_{i'}^{i''} \right) \left(\delta_j^{j'} m_i^{i'} + \sigma_j^{j'} \delta_i^{i'} \right) \phi^{i,j} \\ & + \bar{\phi}_{i'',j''} \left(\delta_{j'}^{j''} \tilde{m}_{i'}^{i''} - \sigma_{j'}^{j''} \delta_{i'}^{i''} \right) \left(\delta_j^{j'} \tilde{m}_i^{i'} - \sigma_j^{j'} \delta_i^{i'} \right) \tilde{\phi}^{i,j} \end{aligned} \quad (4.49)$$

where ϕ and $\bar{\phi}$ contain renormalisation factors. With the results of [34] in mind, q_i are set to equal one for all i . Also, the scalars $\sigma_j^{j'}$ are gauge rotated to be diagonal.

The equations that minimise this potential are [34]:

$$D_{j'}^j \propto \left(4\pi \bar{\phi}_{i,j'} \phi^{i,j} - 4\pi \bar{\phi}_{i,j'} \tilde{\phi}^{i,j} - \zeta_{\text{eff}} \delta_{j'}^j - k_{\text{eff}} \sigma_{j'}^j \right) = 0 \quad (4.50)$$

and:

$$\left(\delta_j^{j'} m_i^{i'} + \sigma_j^{j'} \delta_i^{i'} \right) \phi^{i,j} = 0 \quad (4.51)$$

$$\left(\delta_j^{j'} \tilde{m}_i^{i'} - \sigma_j^{j'} \delta_i^{i'} \right) \tilde{\phi}^{i,j} = 0 \quad (4.52)$$

4.6 Axial and Vector Masses

Above it was shown that the effective mass term of a single flavour of 3d $U(1)$ matter is given by [34]:

$$(m + \sigma)^2 |\phi|^2 \quad (4.53)$$

where q is taken to equal one, and the effective mass is given by $m_{\text{eff}} = m + \sigma$.

Similarly, the effective mass term of the single flavour of antimatter is given by [34]:

$$(\tilde{m} - \sigma)^2 |\tilde{\phi}|^2 \quad (4.54)$$

Define the ‘axial’ and ‘vector’ masses as [37]:

$$m_A = \frac{1}{2}(m + \tilde{m}) \quad \text{and} \quad m_V = \frac{1}{2}(m - \tilde{m}) \quad (4.55)$$

respectively. m and \tilde{m} generally take different values. There is freedom to shift the scalar σ by an arbitrary value, allowing m and \tilde{m} to be set to the same value. The result of this is that $m = \tilde{m} = m_A$ and $m_V = 0$. To see this, consider an example of m and \tilde{m} with different values:

$$m = 2 \quad \tilde{m} = 4 \quad (4.56)$$

The corresponding mass terms are:

$$(2 + \sigma(x))^2 |\phi|^2 \quad (4.57)$$

$$(4 - \sigma(x))^2 |\tilde{\phi}|^2 \quad (4.58)$$

Since σ is added to m and taken away from \tilde{m} , a shift can always be introduced such that the overall number added to σ is the same in both of the terms above. In this case the shift is $\sigma(x) \rightarrow \sigma(x) + 1$, giving:

$$(2 + \sigma(x) + 1)^2 |\phi|^2 = (3 + \sigma(x))^2 |\phi|^2 \quad (4.59)$$

$$(4 - \sigma(x) - 1)^2 |\tilde{\phi}|^2 = (3 - \sigma(x))^2 |\tilde{\phi}|^2 \quad (4.60)$$

So setting $m = 2$, $\tilde{m} = 4$ and including a shift $\sigma(x) \rightarrow \sigma(x) + 1$ is equivalent to simply using $m = \tilde{m} = 3$. The upshot is that the freedom to shift $\sigma(x)$ can be used to set $m = \tilde{m} = (1/2)(m + \tilde{m}) = m_A$, and $m_V = 0$. In this case the mass terms become:

$$(m_A + \sigma(x))^2 |\phi|^2 \quad (4.61)$$

$$(m_A - \sigma(x))^2 |\tilde{\phi}|^2 \quad (4.62)$$

4.7 3d $N = 2$ with Adjoint Matter

It is possible to reduce supersymmetry from 3d $N = 4$ to 3d $N = 2$ without giving mass to the adjoint chiral superfield Φ . Instead it is possible to make the transition by giving Φ a superpotential [4, 38, 39, 40, 41]:

$$\int d^2\theta W(x) = \int d^2\theta \sum_{i=0}^n \frac{c_i}{n+1-i} \Phi^{n+1-i} \quad (4.63)$$

Taking the derivative with respect to Φ gives [41, 42]:

$$W'(x) = \sum_{i=0}^n c_i \Phi^{n-i} = c_0 \prod_{j=1}^n (\Phi - a_j) \quad (4.64)$$

For some constant a_j .

The second equality of equation 4.64 can be seen by choosing a value for n and writing the terms explicitly. Consider $n = 3$ as an example; the first equality becomes:

$$\begin{aligned} W'(x) &= \sum_{j=0}^n c_j x^{n-j} \\ &= c_0 x^{3-0} + c_1 x^{3-1} + c_2 x^{3-2} + c_3 x^{3-3} \\ &= c_0 x^3 + c_1 x^2 + c_2 x + c_3 \end{aligned} \quad (4.65)$$

For the second equality, $n = 3$ gives:

$$\begin{aligned}
W'(x) &= c_0 \prod_{i=1}^n (x - a_i) \\
&= c_0 (x - a_1) (x - a_2) (x - a_3) \\
&= (c_0 x - c_0 a_1) (x - a_2) (x - a_3) \\
&= (c_0 x^2 - c_0 x a_2 - c_0 a_1 x + c_0 a_1 a_2) (x - a_3) \\
&= c_0 x^3 - c_0 x^2 a_2 - c_0 a_1 x^2 + c_0 a_1 a_2 x \\
&\quad - c_0 x^2 a_3 + c_0 x a_2 a_3 + c_0 a_1 x a_3 - c_0 a_1 a_2 a_3
\end{aligned} \tag{4.66}$$

Now, a_1 , a_2 and a_3 are just constants that can be chosen to match accordingly with c_0 , c_1 , c_2 and c_3 . Taking $c_1 = -c_0 a_2 - c_0 a_1 - c_0 a_3$, $c_2 = c_0 a_1 a_2 + c_0 a_2 a_3 + a_1 a_3$ and $c_3 = -c_0 a_1 a_2 a_3$ gives:

$$W'(x) = c_0 x^3 + c_1 x^2 + c_2 x + c_3 \tag{4.67}$$

as required.

The benefit of writing the superpotential as in the second equality of equation 4.64 is that it shows that the superpotential equals zero (has minima) at the values $x = a_j$. The superpotential has up to n distinct minima corresponding to $x = a_j = a_1, \dots, a_n$. Each vacua is labelled by an integer r_i and the result of the superpotential is that the gauge group is Higgsed:

$$U(N_c) \rightarrow U(r_1) \times U(r_2) \times \dots \times U(r_n) \tag{4.68}$$

This corresponds to n different gauge groups of the 3d $N = 2$ theory.

Aharony and Giveon-Kutasov dualities are discussed in sections 7.4.1 and 7.5.1. In these sections generalisations of these dualities with the inclusion of adjoint matter are mentioned. In section 9, the results for flows between these dualities are explained.

5 Induced Chern-Simons Level from Integrating Out Massive Matter

An important feature of (1 + 2)d field theory is that massive matter can be integrated out, resulting in a contribution to the Chern-Simons level of the low energy effective field theory. This important mechanism is used repeatedly in the results section (section III) to adjust the Chern-Simons level of a variety of low energy theories. Since the type of strong-weak duality exhibited in the low energy theory is dependent on the Chern-Simons level, this in turn allows a ‘flow’ between dualities to be displayed. This section provides an explanation of why Chern-Simons levels are induced by integrating out massive matter.

5.1 Inducing Abelian Chern-Simons Terms

Both abelian and non-abelian Chern-Simons terms can be induced in a low energy effective field theory by integrating out matter or antimatter. A derivation of the induced abelian Chern-Simons term is discussed here.

Integrating Out Matter in an Abelian Gauge Theory

Contained in the Lagrangian density is the matter superfield term $Q^\dagger e^{qV} Q$. This is actually contained within $Q^\dagger e^{qV + im\theta\bar{\theta}} Q$, but expanding out the latter shows that it contains all the terms of the former. $Q^\dagger e^{qV} Q$ contains the term:

$$\begin{aligned} \mathcal{L} \ni \bar{\psi}(x) (i\cancel{D} + qA(x) - iq\sigma(x)) \psi(x) \\ = i\bar{\psi}(x) (\cancel{D} - iqA(x) - q\sigma(x)) \psi(x) \end{aligned} \quad (5.1)$$

Using $q = 1$, the covariant derivative is written [33]:

$$\begin{aligned} D_\mu &= \partial_\mu - iA_\mu \\ &= \partial_\mu - iqA_\mu \end{aligned} \quad (5.2)$$

This gives:

$$\begin{aligned} \mathcal{L} \ni i\bar{\psi}(x) (\cancel{D} - q\sigma(x)) \psi(x) \\ = -i\bar{\psi}(x) (-\cancel{D} + q\sigma(x)) \psi(x) \\ = -\psi^*(x) (i\gamma^0) (-\cancel{D} + q\sigma(x)) \psi(x) \end{aligned} \quad (5.3)$$

The effective action obtained by integrating out massive matter is defined [43]:

$$e^{-S_{\text{eff}}} = \int d\bar{\psi}d\psi e^{-\int \psi^*(x)(i\gamma^0)(-\not{D}+q\sigma(x))\psi(x)d^3x} \quad (5.4)$$

The right hand side can be rewritten [44]:

$$\begin{aligned} e^{-S_{\text{eff}}} &= \text{Det}((i\gamma^0)(-\not{D}+q\sigma(x))) \\ &= \text{Det}((-\gamma^0)(-i)(-\not{D}+q\sigma(x))) \\ &= \text{Det}(-\gamma^0) \text{Det}(i\not{D}-iq\sigma(x)) \\ &= \text{Det}\begin{pmatrix} 0 & -1 \\ 1 & 0 \end{pmatrix} \text{Det}(i\not{D}-iq\sigma(x)) \\ &= \text{Det}(i\not{D}-iq\sigma(x)) \end{aligned} \quad (5.5)$$

This gives:

$$\begin{aligned} \ln e^{-S_{\text{eff}}} &= \ln \text{Det}(i\not{D}-iq\sigma(x)) \\ \rightarrow -S_{\text{eff}} &= \ln \text{Det}(i\not{D}-iq\sigma(x)) \\ \rightarrow S_{\text{eff}} &= -\ln \text{Det}(i\not{D}-iq\sigma(x)) \\ &= -\ln \text{Det}(i\not{\partial}+q\not{A}-iq\sigma(x)) \end{aligned} \quad (5.6)$$

This can be rewritten [44]:

$$\begin{aligned} S_{\text{eff}} &= -\ln \text{Det} \left[(i\not{\partial}-iq\sigma(x)) \left(1 - \frac{i}{(i\not{\partial}-iq\sigma(x))} (+iq\not{A}) \right) \right] \\ &= -\ln \left[\text{Det}(i\not{\partial}-iq\sigma(x)) \text{Det} \left(1 - \frac{i}{(i\not{\partial}-iq\sigma(x))} (+iq\not{A}) \right) \right] \end{aligned} \quad (5.7)$$

Using [44]⁶:

$$\begin{aligned} &\text{Det} \left(1 - \frac{i}{(i\not{\partial}-iq\sigma(x))} (+iq\not{A}) \right) \\ &= \exp \left(\sum_{n=1}^{\infty} -\frac{1}{n} \text{Tr} \left[\left(\frac{i}{(i\not{\partial}-iq\sigma(x))} (+iq\not{A}) \right)^n \right] \right) \end{aligned} \quad (5.8)$$

⁶Here the relation $\text{Det}(1+y) = \exp(\text{Tr}(\ln(1+y)))$ is used, then $\ln(1+y)$ is expanded out. Thank you to Dr Sanjaye Ramgoolam and Dr Ian Jack for pointing this out.

this becomes:

$$\begin{aligned}
S_{\text{eff}} &= -\ln \text{Det} \left[(i\cancel{\partial} - iq\sigma(x)) \left(1 - \frac{i}{(i\cancel{\partial} - iq\sigma(x))} (+iqA) \right) \right] \\
&= -\ln \left[\text{Det} (i\cancel{\partial} - iq\sigma(x)) \exp \left(\sum_{n=1}^{\infty} -\frac{1}{n} \text{Tr} \left[\left(\frac{i}{(i\cancel{\partial} - iq\sigma(x))} (+iqA) \right)^n \right] \right) \right] \quad (5.9)
\end{aligned}$$

Using $\ln(\alpha A) = \ln(\alpha)I + \ln(A)$ for $\alpha \in \mathbb{R}$ and $I = \text{identity}$ ⁷:

$$\begin{aligned}
S_{\text{eff}} &= -\ln [\text{Det} (i\cancel{\partial} - iq\sigma(x))] + \sum_{n=1}^{\infty} \frac{1}{n} \text{Tr} \left[\left(\frac{i}{(i\cancel{\partial} - iq\sigma(x))} (+iqA) \right)^n \right] \\
&= -\ln [\text{Det} (i\cancel{\partial} - iq\sigma(x))] + \text{Tr} \left(\frac{i}{(i\cancel{\partial} - iq\sigma(x))} (+iqA) \right) \quad (5.10) \\
&\quad + \frac{1}{2} \text{Tr} \left[\left(\frac{i}{(i\cancel{\partial} - iq\sigma(x))} (+iqA) \right)^2 \right] + \dots
\end{aligned}$$

Since the aim is to prove that the abelian Chern-Simons term is induced, and since the Abelian Chern-Simons term is quadratic in the gauge field A , only the third term on the right hand side needs to be considered [45]. Denoting the part of S_{eff} that is quadratic in A as $S_{\text{eff} (A)}$ to emphasise that it contains the Abelian gauge term:

$$S_{\text{eff} (A)} = + \frac{1}{2} \text{Tr} \left[\left(\frac{i}{(i\cancel{\partial} - iq\sigma(x))} (+iqA) \right)^2 \right] \quad (5.11)$$

Write $-iq\sigma(x) := m$ for convenience [45]:

$$\begin{aligned}
S_{\text{eff} (A)} &= + \frac{1}{2} \text{Tr} \left[\left(\frac{i}{(i\cancel{\partial} + m)} (+iqA) \right)^2 \right] \\
&= + \frac{1}{2} \text{Tr} \left[\frac{i}{(i\cancel{\partial} + m)} (+iqA) \frac{i}{(i\cancel{\partial} + m)} (+iqA) \right] \quad (5.12)
\end{aligned}$$

The terms in the square bracketes correspond to the Feynman rules in position space. Switching to momentum space gives:

⁷Thanks to Panos Athanasopoulos.

$$\begin{aligned}
S_{\text{eff (A)}} &= \frac{1}{2} \text{Tr} \left[\frac{i}{(i\not{\partial} + m)} (iqA) \frac{i}{(i\not{\partial} + m)} (iqA) \right] \\
&= \frac{1}{2} \int \frac{d^3p}{(2\pi)^3} \int \frac{d^3k}{(2\pi)^3} \text{Tr} \left[(iq\gamma^\mu A_\mu(-p)) \underbrace{\left(\frac{i(\not{p} + \not{k} - m)}{(p+k)^2 + m^2} \right)}_{\text{propagator}} \underbrace{\left(\frac{i(\not{k} - m)}{k^2 + m^2} \right)}_{\text{propagator}} (iq\gamma^\nu A_\nu(p)) \right] \\
&\quad \left(\text{Diagram: } \otimes \xrightarrow{p} \text{circle} \xrightarrow{p} \otimes \right) = \left(\text{Diagram: } \otimes \xrightarrow{p} \text{triangle} \right) \left(\text{Diagram: } \xrightarrow{p+k} \text{line} \right) \left(\text{Diagram: } \xrightarrow{k} \text{line} \right) \left(\text{Diagram: } \text{triangle} \xrightarrow{p} \otimes \right)
\end{aligned} \tag{5.13}$$

Contained within the above expression is:

$$\begin{aligned}
&\gamma^\mu \frac{i(\not{p} + \not{k} - m)}{(p+k)^2 + m^2} \gamma^\nu \frac{i(\not{k} - m)}{k^2 + m^2} \\
&= \frac{(i\gamma^\mu \gamma^a p_a + i\gamma^\mu \gamma^b k_b - i\gamma^\mu m) (i\gamma^\nu \gamma^c k_c - i\gamma^\nu m)}{\left((p+k)^2 + m^2 \right) (k^2 + m^2)} \\
&= \frac{-\gamma^\mu \gamma^a p_a \gamma^\nu \gamma^c k_c - \gamma^\mu \gamma^b k_b \gamma^\nu \gamma^c k_c + \gamma^\mu m \gamma^\nu \gamma^c k_c}{\left((p+k)^2 + m^2 \right) (k^2 + m^2)} \\
&\quad + \frac{\gamma^\mu \gamma^a p_a \gamma^\nu m + \gamma^\mu \gamma^b k_b \gamma^\nu m - \gamma^\mu \gamma^\nu m^2}{\left((p+k)^2 + m^2 \right) (k^2 + m^2)}
\end{aligned} \tag{5.14}$$

The abelian Chern-Simons term contains $\epsilon^{\mu\nu\rho}$ which is related to the gamma matrices by:

$$\text{Tr} (\gamma^\mu \gamma^\nu \gamma^\rho) = -2\epsilon^{\mu\nu\rho} \tag{5.15}$$

Therefore, in order to find the induced Chern-Simons terms, only those terms in equation 5.14 with three γ s need to be considered [45]:

$$\begin{aligned}
& \frac{\gamma^\mu \gamma^a p_a \gamma^\nu m + \gamma^\mu \gamma^b k_b \gamma^\nu m + \gamma^\mu m \gamma^\nu \gamma^c k_c}{\left((p+k)^2 + m^2 \right) (k^2 + m^2)} \\
&= \frac{\gamma^\mu \gamma^a \gamma^\nu p_a m + \gamma^\mu \gamma^b \gamma^\nu k_b m + \gamma^\mu \gamma^\nu \gamma^c k_c m}{\left((p+k)^2 + m^2 \right) (k^2 + m^2)} \\
&= \frac{\gamma^\mu \gamma^\rho \gamma^\nu p_\rho m + \gamma^\mu \gamma^\rho \gamma^\nu k_\rho m + \gamma^\mu \gamma^\nu \gamma^\rho k_\rho m}{\left((p+k)^2 + m^2 \right) (k^2 + m^2)} \\
&= \frac{\gamma^\mu \gamma^\rho \gamma^\nu p_\rho m - \cancel{\gamma^\mu \gamma^\nu \gamma^\rho k_\rho m} + \cancel{\gamma^\mu \gamma^\nu \gamma^\rho k_\rho m}}{\left((p+k)^2 + m^2 \right) (k^2 + m^2)} \\
&= \frac{\gamma^\mu \gamma^\rho \gamma^\nu p_\rho m}{\left((p+k)^2 + m^2 \right) (k^2 + m^2)} \\
&= - \frac{\gamma^\mu \gamma^\nu \gamma^\rho p_\rho m}{\left((p+k)^2 + m^2 \right) (k^2 + m^2)}
\end{aligned} \tag{5.16}$$

As a result:

$$\begin{aligned}
& S_{\text{eff (A)}} \ni S_{\text{eff (A)(CS)}} \\
&= \frac{1}{2} \int \frac{d^3 p}{(2\pi)^3} \int \frac{d^3 k}{(2\pi)^3} \text{Tr} \left[(iq A_\mu(-p)) \left(\frac{-\gamma^\mu \gamma^\nu \gamma^\rho p_\rho m}{\left((p+k)^2 + m^2 \right) (k^2 + m^2)} \right) (iq A_\nu(p)) \right] \\
&= \frac{(iq)^2}{2} \int \frac{d^3 p}{(2\pi)^3} \int \frac{d^3 k}{(2\pi)^3} \text{Tr} \left[(A_\mu(-p)) \left(\frac{-\gamma^\mu \gamma^\nu \gamma^\rho p_\rho m}{\left((p+k)^2 + m^2 \right) (k^2 + m^2)} \right) (A_\nu(p)) \right]
\end{aligned} \tag{5.17}$$

Using the identity 5.15 this becomes [45]:

$$\begin{aligned}
& S_{\text{eff (A)(CS)}} \\
&= \frac{(iq)^2}{2} \int \frac{d^3 p}{(2\pi)^3} \int \frac{d^3 k}{(2\pi)^3} \left[(A_\mu(-p)) \left(\frac{2\epsilon^{\mu\nu\rho} p_\rho m}{((p+k)^2 + m^2)(k^2 + m^2)} \right) (A_\nu(p)) \right] \\
&= -\frac{q^2}{2} \int \frac{d^3 p}{(2\pi)^3} \left[(A_\mu(-p)) \left(\int \frac{d^3 k}{(2\pi)^3} \left(\frac{2\epsilon^{\mu\nu\rho} p_\rho m}{((p+k)^2 + m^2)(k^2 + m^2)} \right) \right) (A_\nu(p)) \right] \\
&= -\frac{q^2}{2} \int \frac{d^3 p}{(2\pi)^3} \left[(A_\mu(-p)) \left(2m\epsilon^{\mu\nu\rho} p_\rho \int \frac{d^3 k}{(2\pi)^3} \right. \right. \\
&\quad \left. \left. \left(\frac{1}{((p+k)^2 + m^2)(k^2 + m^2)} \right) \right) (A_\nu(p)) \right]
\end{aligned} \tag{5.18}$$

It is possible to show that [45]:

$$\begin{aligned}
& \int_{-\infty}^{\infty} \frac{d^3 k}{(2\pi)^3} \frac{1}{((p+k)^2 + m^2)(k^2 + m^2)} \\
&= \frac{1}{4\pi i} \frac{1}{|p|} \arcsin \left(\frac{|p|}{\sqrt{p^2 + 4m^2}} \right)
\end{aligned} \tag{5.19}$$

The proof is lengthy, and is written in appendix C.1. Using equation 5.19, equation 5.18 becomes:

$$\begin{aligned}
& S_{\text{eff (A)(CS)}} \\
&= -\frac{q^2}{2} \int \frac{d^3 p}{(2\pi)^3} \left[(A_\mu(-p)) \left(2m\epsilon^{\mu\nu\rho} p_\rho \frac{1}{4\pi i} \frac{1}{|p|} \arcsin \left(\frac{|p|}{\sqrt{p^2 + 4m^2}} \right) \right) (A_\nu(p)) \right] \\
&= -\frac{q^2}{2} \int \frac{d^3 p}{(2\pi)^3} \left[(A_\mu(-p)) \left(\epsilon^{\mu\nu\rho} p_\rho \frac{1}{2\pi i} \frac{m}{|p|} \arcsin \left(\frac{|p|}{\sqrt{p^2 + 4m^2}} \right) \right) (A_\nu(p)) \right]
\end{aligned} \tag{5.20}$$

The Taylor expansion of the arcsin term is taken:

$$\arcsin(x) = \int_0^x \frac{dx}{\sqrt{1-x^2}} = a + \frac{a^3}{6} + \frac{3a^5}{40} + \frac{5a^7}{112} + \dots \tag{5.21}$$

giving:

$$\begin{aligned}
& \epsilon^{\mu\nu\rho} p_\rho \frac{1}{2\pi i} \frac{m}{|p|} \arcsin\left(\frac{|p|}{\sqrt{p^2 + 4m^2}}\right) \\
&= \epsilon^{\mu\nu\rho} p_\rho \frac{1}{2\pi i} \frac{m}{|p|} \left(\frac{|p|}{\sqrt{p^2 + 4m^2}} + \frac{1}{6} \left(\frac{|p|}{\sqrt{p^2 + 4m^2}} \right)^3 + \dots \right) \\
&= \epsilon^{\mu\nu\rho} p_\rho \frac{1}{2\pi i} \frac{m}{\sqrt{p^2 + 4m^2}} + \epsilon^{\mu\nu\rho} p_\rho \frac{1}{2\pi i} \frac{m}{|p|} \frac{1}{6} \left(\frac{|p|}{\sqrt{p^2 + 4m^2}} \right)^3 + \dots
\end{aligned} \tag{5.22}$$

Taking the long wavelength ($p \rightarrow 0$) and large mass ($m \rightarrow \infty$) limit gives [45]:

$$\begin{aligned}
& \epsilon^{\mu\nu\rho} p_\rho \frac{1}{2\pi i} \frac{m}{|p|} \arcsin\left(\frac{|p|}{\sqrt{p^2 + 4m^2}}\right) \Big|_{p \rightarrow 0, m \rightarrow \infty} \\
&= \epsilon^{\mu\nu\rho} p_\rho \frac{1}{2\pi i} \frac{m}{\sqrt{4m^2}} + \epsilon^{\mu\nu\rho} p_\rho \frac{1}{2\pi i} \frac{m}{|p|} \frac{1}{6} \left(\frac{|p|}{\sqrt{4m^2}} \right)^3 + \dots \\
&= \epsilon^{\mu\nu\rho} p_\rho \frac{1}{2\pi i} \frac{m}{2|m|} + \epsilon^{\mu\nu\rho} p_\rho \frac{1}{2\pi i} \frac{1}{6} \frac{m|p|^2}{(\sqrt{4m^2})^3} + \dots \\
&= \epsilon^{\mu\nu\rho} p_\rho \frac{1}{4\pi i} \frac{m}{|m|} + \epsilon^{\mu\nu\rho} p_\rho \frac{1}{2\pi i} \frac{1}{6} \frac{m|p|^2}{2^3 m^3} + \dots \\
&= \epsilon^{\mu\nu\rho} p_\rho \frac{1}{4\pi i} \frac{m}{|m|} + \epsilon^{\mu\nu\rho} p_\rho \frac{1}{96\pi i} \frac{m|p|^2}{m^2} + \dots \\
&= \epsilon^{\mu\nu\rho} p_\rho \frac{1}{4\pi i} \frac{m}{|m|} + \mathcal{O}\left(\frac{|p|^2}{m^2}\right) \dots
\end{aligned} \tag{5.23}$$

The second term is vanishingly small, and so only the first term needs to be plugged back into equation 5.20:

$$\begin{aligned}
S_{\text{eff (A)(CS)}} &= -\frac{q^2}{2} \int \frac{d^3 p}{(2\pi)^3} \left[(A_\mu(-p)) \epsilon^{\mu\nu\rho} p_\rho \frac{1}{4\pi i} \frac{m}{|m|} (A_\nu(p)) \right] \\
&= -\frac{q^2}{2} \frac{1}{4\pi i} \frac{m}{|m|} \int \frac{d^3 p}{(2\pi)^3} [(A_\mu(-p)) \epsilon^{\mu\nu\rho} p_\rho (A_\nu(p))]
\end{aligned} \tag{5.24}$$

Switching back to coordinate space ($A_\mu(p) \rightarrow A_\nu(x)$, $p_\rho \rightarrow -i\partial_\rho$) gives:

$$\begin{aligned}
S_{\text{eff (A)(CS)}} &= -\frac{q^2}{2} \frac{1}{4\pi i} \frac{m}{|m|} (-i) \int d^3 x \epsilon^{\mu\nu\rho} A_\mu(x) \partial_\rho A_\nu(x) \\
&= \frac{q^2}{2} \frac{1}{4\pi} \frac{m}{|m|} \int d^3 x \epsilon^{\mu\nu\rho} A_\mu(x) \partial_\rho A_\nu(x)
\end{aligned} \tag{5.25}$$

Using $\epsilon^{\mu\nu\rho} = -\epsilon^{\mu\rho\nu}$:

$$S_{\text{eff (A)(CS)}} = -\frac{q^2}{2} \frac{1}{4\pi} \frac{m}{|m|} \int d^3x \epsilon^{\mu\nu\rho} A_\mu(x) \partial_\rho A_\nu(x) \quad (5.26)$$

Relabelling the dummy indices for aesthetics [45]:

$$S_{\text{eff (A)(CS)}} = -\frac{q^2}{2} \frac{1}{4\pi} \frac{m}{|m|} \int d^3x \epsilon^{\mu\nu\rho} A_\mu(x) \partial_\nu A_\rho(x) \quad (5.27)$$

Interpreting the result: Pauli-Villars regularisation gives the regularised action as [45]:

$$S_{\text{eff (A)(CS)}}^{\text{Reg}} [A, m = 0] = S_{\text{eff (A)(CS)}} [A, m = 0] - \lim_{m \rightarrow \infty} S_{\text{eff (A)(CS)}} [A, M] \quad (5.28)$$

The second term on the right hand side corresponds to equation 5.27. It is what is taken away from the low energy action to give the regularised low energy action. The result is that the low energy action has the following term added to it:

$$\text{Induced CS-term} = - \lim_{m \rightarrow \infty} S_{\text{eff (A)(CS)}} = \frac{q^2}{2} \frac{1}{4\pi} \frac{m}{|m|} \int d^3x \epsilon^{\mu\nu\rho} A_\mu(x) \partial_\nu A_\rho(x) \quad (5.29)$$

Integrating Out Antimatter in an Abelian Gauge Theory

The procedure for antimatter is very similar to that of matter. Where the matter contributed a Lagrangian density term:

$$Q^\dagger e^{qV} Q \quad (5.30)$$

antimatter contributes:

$$\bar{Q}^\dagger e^{-qV} \bar{Q} = Q e^{-qV} Q^\dagger \quad (5.31)$$

The only difference when figuring out the Chern-Simons contribution is that now the q has a minus in front. The Chern-Simons contribution is:

$$\text{Induced CS-term} = - \lim_{m \rightarrow \infty} S_{\text{eff (A)(CS)}} = \frac{(-q)^2}{2} \frac{1}{4\pi} \frac{m}{|m|} \int d^3x \epsilon^{\mu\nu\rho} A_\mu(x) \partial_\nu A_\rho(x) \quad (5.32)$$

Since $q = 1$ is used in both the matter and antimatter cases, and since $-q$ is squared in the above expression, the upshot is that the Chern-Simons term contribution is the same if matter is integrated out or if anti-matter is integrated out, provided the mass terms m of the matter and antimatter have the same sign.

5.2 Inducing Non-abelian Chern-Simons Terms

Integrating out matter or antimatter can induce non-abelian Chern-Simons terms in the low energy effective action.

Integrating out Matter in a Non-abelian Gauge Theory

In the non-abelian theory the matter term includes:

$$\text{Tr} \left(Q^\dagger e^{qV} Q \right) \quad (5.33)$$

With the trace over the gauge indices:

$$Q_{j'}^\dagger (e^{qV})_j^{j'} Q^j \quad (5.34)$$

where:

$$(e^{qV})_j^{j'} := 1 + (qV_j^{j'}) + \frac{1}{2} (qV_{j''}^{j'}) (qV_j^{j''}) \quad (5.35)$$

Here $V_j^{j'} := V^a (T_a)_j^{j'}$, with $a = 1, \dots, N_c$. Amongst the terms in the superfield expansion is:

$$\mathcal{L} \ni -\bar{\psi}_{j'}(x) \left(i\cancel{\partial} \delta_j^{j'} + qA_j^{j'}(x) - iq\sigma_j^{j'}(x) \right) \psi^j(x) \quad (5.36)$$

Following the same methods as in section 5.1 gives the induced Chern-Simons term:

$$\frac{q^2}{2} \frac{1}{4\pi} \frac{m}{|m|} \int d^3x \epsilon^{\mu\nu\rho} \text{Tr} (A_\mu(x) \partial_\nu A_\rho(x)) \quad (5.37)$$

where $A_j^{j'} = A^a (T_a)_j^{j'}$. However this is not the whole story. Recall that, for the abelian case, only terms that were quadratic in the gauge field were considered. The cubic gauge field terms could have been considered also, and would have given rise to the induced term:

$$\frac{q^2}{2} \frac{1}{4\pi} \frac{m}{|m|} \int d^3x \epsilon^{\mu\nu\rho} \text{Tr} \left(\frac{2}{3} A_\mu(x) A_\nu(x) A_\rho(x) \right) \quad (5.38)$$

However this term is ignored in the abelian case [45]. This is because the A_μ , A_ν and A_ρ commute with each other, and $\epsilon^{\mu\nu\rho}$ is antisymmetric, so the term disappears. In the non-abelian case (where $A_j^{j'} = A^a (T_a)_j^{j'}$) the gauge fields do not commute, and so both 5.37 and 5.38 are kept. This gives the induced term:

$$\boxed{\frac{q^2}{2} \frac{1}{4\pi} \frac{m}{|m|} \int d^3x \epsilon^{\mu\nu\rho} \text{Tr} \left(A_\mu(x) \partial_\nu A_\rho(x) + \frac{2}{3} A_\mu(x) A_\nu(x) A_\rho(x) \right)} \quad (5.39)$$

which is the non-abelian Chern-Simons term.

Integrating out Antimatter in a Non-abelian Gauge Theory

As for the abelian case, the only difference between integrating out matter and antimatter is that q acquires a negative sign in front for antimatter. Again, this is only written symbolically since $(-q)^2 = (-1)^2(q)^2 = q^2$:

$$\boxed{\frac{(-q)^2}{2} \frac{1}{4\pi} \frac{m}{|m|} \int d^3x \epsilon^{\mu\nu\rho} \text{Tr} \left(A_\mu(x) \partial_\nu A_\rho(x) + \frac{2}{3} A_\mu(x) A_\nu(x) A_\rho(x) \right)} \quad (5.40)$$

Integrating out Matter and Antimatter in a Non-abelian Gauge Theory with N_f Flavours

The generalisation to multiple flavours is very straightforward. The terms are simply summed over the N_f different flavours. For example, for N_f flavours in a non-abelian gauge theory, there are N_f matter terms:

$$Q_{1,j'}^\dagger (e^{q_1 V})_j^{j'} Q^{1,j} + Q_{2,j'}^\dagger (e^{q_2 V})_j^{j'} Q^{2,j} + \dots + Q_{N_f,j'}^\dagger (e^{q_{N_f} V})_j^{j'} Q^{N_f,j} \quad (5.41)$$

where:

$$(e^{q_i V})_j^{j'} := 1 + (q_i V_j^{j'}) + \frac{1}{2} (q_i V_j^{j'}) (q_i V_j^{j''}) \quad (5.42)$$

For each of these flavours of matter that are massive, there is a term 5.39. So in total there could be N_F such terms contributed. The generalisation is the same for antimatter; for each massive flavour, a corresponding induced Chern-Simons term 5.40 is added to the effective regularised Lagrangian density.

5.3 Fractional Chern-Simons Level

As will be seen in part III, depending on the particular brane configuration used, sometimes the induced level of a gauge group is fractional. It should be noted that a fractional Chern-Simons level is acceptable for abelian theories, however, for non-abelian theories, it is inconsistent with ‘level quantisation’ [41]. Level quantisation is explained further in appendix C.2. Note, there are some special cases where fractional Chern-Simons level is permitted in the non-abelian theory, but these cases are not important to this text.

6 3d Effective Field Theories from Branes

Having discussed the types of branes that exist in IIA and IIB string theories (section 3), as well as some of the relevant field theory (sections 4 and 5), it is important to determine how strings ending on the branes give rise to particular field theories. This section will explain the relationship between branes and field theory, eventually building up to brane configurations that give rise to low energy $(1 + 2)$ -dimensional field theories exhibiting Aharony or Giveon-Kutasov duality. Such brane configurations are then used throughout the results section.

6.1 Strings on Dp -branes

An open bosonic string with both ends on a single Dp -brane contributes a negative squared mass (imaginary mass) groundstate tachyon [10, 11, 38]. It also contributes $((p + 1) - 2)$ massless states corresponding to the independent transverse components of a photon. The gauge field of the string on the Dp -brane gives rise to a $(p + 1)$ -dimensional $U(1)$ gauge theory on that brane [38]. Finally, there are $D - 1 - p$ massless scalars [10, 11, 38]. All these fields exist in a $(p + 1)$ -dimensional spacetime. That is, they ‘live’ on the Dp -brane. Supersymmetry can be added to the this $(p + 1)$ -dimensional field theory to find the corresponding fermionic degrees of freedom. GSO projection is then used to remove the tachyons and ensure supersymmetry. When considering the low energy effective theories that arise on branes, only the massless degrees of freedom will be kept. In this case, the string begins and ends on the same brane, allowing the string to shrink to zero length. Consequently, all degrees of freedom are massless.

Multiple Dp -branes and Chan-Paton Factors

When considering theories with multiple branes it will be useful to introduce the concept of Chan-Paton factors. One endpoint of the string is labelled i , and the other is labelled j . Allow these labels to run over $i, j = 1, \dots, N_c$. An open string state can then be written [10]:

$$|p; a\rangle = \sum_{i,j=1}^N |p; ij\rangle \lambda_{ij}^a \quad (6.1)$$

The matrices λ_{ij}^a are called ‘Chan-Paton factors’ [10]. When amplitudes are calculated with these Chan-Paton factors included in the states, the resulting amplitudes are invariant under $U(N_c)$ transformations. This offers a clue as to how to interpret the Chan-Paton indices i and j . If there exist N_c coincident Dp -branes, that is, branes that extend along the same spacetime directions and which exist at the

same transverse coordinates ⁸, then one string endpoint can end on one of N_c different Dp -branes, as can the other string endpoint. Then i and j can be interpreted as a label for which brane the string endpoints end on. For example $i = 1$ and $j = 2$ would mean that one end of the string ends on the first Dp -brane, whilst the other end of the string ends on the second. To see this, recall that a $U(N_c)$ gauge symmetry corresponds to N_c^2 gauge bosons. Now imagine there is only one Dp -brane, corresponding to $N_c = 1$; then the only combination of i and j is $i = j = 1$, corresponding to both ends of string on that Dp -brane. This corresponds to only one kind of open string state, and, as mentioned above, this string state comes with a single massless vector boson. Therefore it gives rise to a $U(1)$ gauge theory.

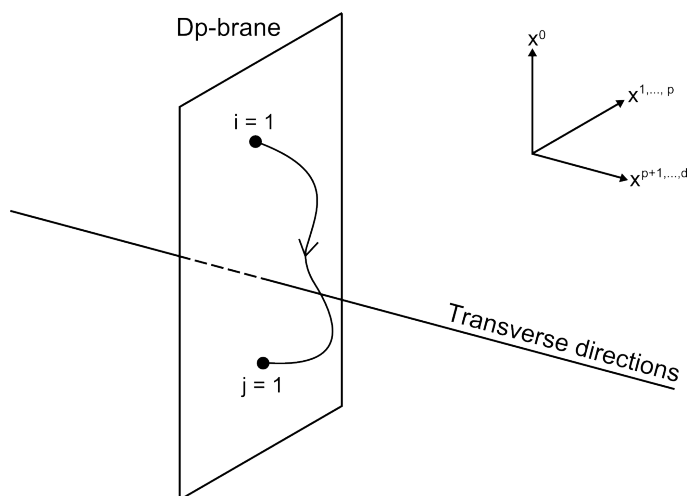

Figure 2: A single Dp -brane gives $N_c = 1$ and corresponds to a $U(1)$ gauge theory. The arrow on the string represents its intrinsic orientation.

Alternatively, consider a stack of two Dp -branes; then $i, j = 1, 2$. This results in four combinations of strings between the Dp -branes. $i, j = 1$ corresponds to a string with both ends on the first Dp -brane, $i, j = 2$ corresponds to a string with both ends on the second Dp -brane, $i = 1, j = 2$ corresponds to a string beginning on the first Dp -brane and ending on the second, and, finally, $i = 2, j = 1$ corresponds to a string beginning on the second Dp -brane and ending on the first. Note that the strings have an intrinsic orientation in this description, so a string from the first to the second is distinguishable from a string from the second to the first. Consequently, there are four different vector bosons from the four different string configurations between the branes, corresponding to a $U(2)$ gauge theory.

⁸Such branes are said to exist in a ‘stack’.

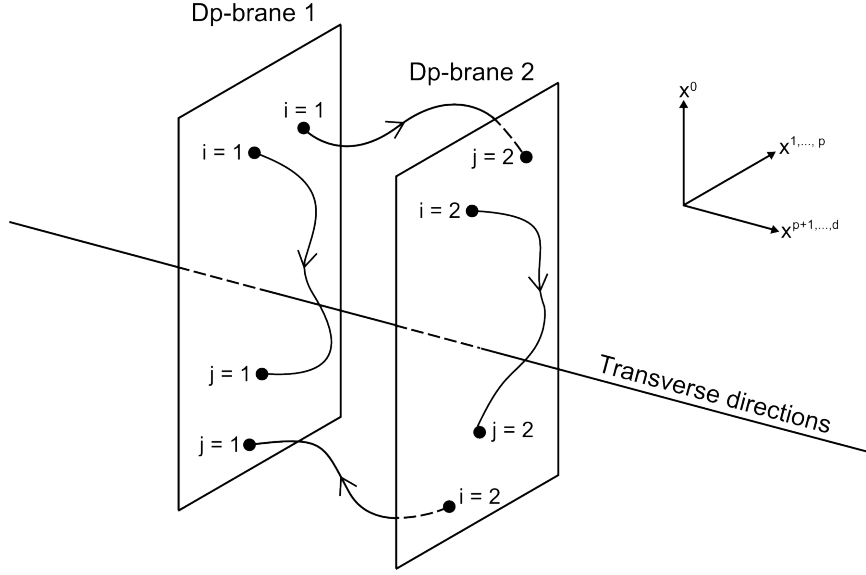

Figure 3: Two Dp -brane give $N_c = 2$ and correspond to a $U(2)$ gauge theory. The arrow on the strings represent their intrinsic orientation. The branes are drawn as separated in the transverse directions, this was just to show that they are distinct, and to clearly show the strings between them. In actuality, the left and right branes are coincident, with zero separation in the transverse directions.

By a similar analysis of the permutations of i and j values, it is clear that $N_c = 3$ corresponds to three Dp -branes, which give rise to nine different string configurations and nine gauge bosons. That is, a $U(3)$ gauge theory. In conclusion, a stack of N_c Dp -branes results in a $U(N_c)$ theory with N_c^2 vector bosons.

Note that two Dp -branes with a relative separation will have massive gauge bosons from the strings between them (such strings have non-zero tension, and give rise to massive vector bosons) [10]. This would correspond to two massive gauge bosons and two massless gauge bosons. Since, for phenomenological purposes, only low energy states are considered, massive states from separated branes are often ignored. As a result, a stack of $N_{c,1}$ Dp -branes and a stack of $N_{c,2}$ Dp -branes which are separated in the transverse directions correspond to a $U(N_{c,1}) \times U(N_{c,2})$ gauge theory at low energies.

The Chan-Paton factors of strings were originally used in describing quarks and anti-quarks that were joined by a flux tube. They were later applied to the strings in string theory. Remember that a quark transforms as a $\mathbf{3}$ under $SU(3)$, and an anti-quark transforms as a $\bar{\mathbf{3}}$ under $SU(3)$ [46]. Similarly, for a string beginning and ending on a stack of N_c D3-branes (for example), one end of the string transforms as an \mathbf{N}_c under $U(N_c)$, and the other end transforms as an $\bar{\mathbf{N}}_c$ under $U(N_c)$. Also, just as the quark and the anti-quark can take one of three different color, the ends of the string are attributed with one of N_c different charges. The different charges are

labelled by the Chan-Paton indices $i, j = 1, \dots, N_c$. As a matter of convention, for a string oriented from end point i to endpoint j , it is the i end that transforms as a an \mathbf{N}_c , and it is the j end that transforms as an $\bar{\mathbf{N}}_c$.

This text is primarily interested in $(1 + 2)$ -dimensional effective field theories. One way to obtain an effective $(1 + 2)$ d $U(N_c)$ gauge theory would be to consider a stack of N_c D2-branes. However the method that will be employed is to consider stacks of N_c D3-branes, giving rise to $U(N_c)$ in $(1 + 3)$ d. Then the D3s will be taken to be finite and small along one direction, thereby freezing out that dimension at low energies and giving rise to an effective $(1 + 2)$ d $U(N_c)$ gauge theory.

Summary:

N_c D p -branes in a stack correspond to Chan-Paton indices $i, j = 1, \dots, N_c$ and a $U(N_c)$ gauge theory with N_c^2 vector (gauge) bosons existing on their worldvolumes. These gauge bosons transform under the adjoint action of $U(N_c)$.

A stack of $N_{c,1}$ D p -branes and a stack of $N_{c,2}$ D p -branes which are separated in the transverse directions correspond to a $U(N_{c,1}) \times U(N_{c,2})$ gauge theory at low energy.

A string with both ends on a stack of N_c D p -branes has one end transform as an \mathbf{N}_c under $U(N_c)$, and the other end transforms as a $\bar{\mathbf{N}}_c$ under $U(N_c)$.

A stack of N_c D3-branes that are small along one direction give rise to a 3d $U(N_c)$ effective theory living on the worldvolume of the D3s.

6.2 Flavour Branes

It is important to understand how to add matter fields to the theory. Consider adding a stack of N_f D5-branes that intersect the stack of N_c D3-branes. Since the D3 and D5-branes meet, it is possible to have strings between them of zero length (zero tension). The D3-D3 strings (strings that begin on a D3-brane and end on a D3-brane) give rise to a $U(N_c)$ gauge theory, as discussed in the previous section. There are also D5-D5 strings which give rise to N_f^2 gauge bosons transforming under the adjoint action of $U(N_f)$ [47]. The coupling of a D5-D5-string has dimensions $(\text{length})^{p-3}$ and is proportional to energy E^{p-3} (where, in this case, $p = 5$). This means that, at low energies, the coupling is vanishingly small. As a result, in the low energy theory, the D5-D5-string interactions can be ignored.

The D3-D5 (or D5-D3) string states transform in the fundamental (antifundamental) of $U(N_c)$ and in the antifundamental (fundamental) of $U(N_f)$ [47]. That is they transform in the bifundamental of:

$$U(N_c) \times U(N_f) \tag{6.2}$$

The D3-D5-string transforms as $(\mathbf{N}_c, \bar{\mathbf{N}}_f)$, and the D5-D3-string transforms as $(\bar{\mathbf{N}}_c, \mathbf{N}_f)$. To see why the D3-D5 (D5-D3) strings transform like this, consider the charges at either end of the string. The end of the D3-D5 at the D3-brane (labelled i) transforms as an \mathbf{N}_c and the end at the D5-brane (labelled j) transforms as an $\bar{\mathbf{N}}_f$. The Chan-Paton indices are $i = 1, \dots, N_c$ and $j = 1, \dots, N_f$. This is completely analogous to the strings beginning and ending on the same Dp -brane stack mentioned above. Conversely, the D5-D3 has its end at the D5-brane (labelled i) transform as a $\bar{\mathbf{N}}_c$ and the end at the D3-brane (labelled j) transforms as a \mathbf{N}_f . The Chan-Paton indices are $i = 1, \dots, N_f$ and $j = 1, \dots, N_c$.

However, this description is only accurate at high energies. At low energies the D5-D5 string coupling vanishes and this changes the gauge dynamics. Since the D3-D5 (D5-D3) strings interact with the D5-D5-strings with a strength given by the D5-D5-brane coupling, at low energies, the interactions stop [47]. In this limit the $U(N_f)$ gauge symmetry becomes as global symmetry. The D3-D5-string spectra gives rise to spin 1/2 fermions transforming in the fundamental of $U(N_c)$ and with a global $U(N_f)$ symmetry. Recall from field theory that spin 1/2 fermions with the same mass are expected to have a global flavor symmetry. The $U(N_f)$ group is interpreted as the flavour symmetry group of the string fermions. The D3-D5-string fermions are said to have N_f different flavours. Similarly, the D5-D3-string spectra gives rise to spin 1/2 fermions transforming in the antifundamental of $U(N_c)$ and with a global $U(N_f)$ symmetry. It is no surprise then, that the D5-branes are referred to as a ‘flavour branes’.

Masses are introduced for these quarks by separating the stack of D5-branes from the stack of D3-branes. The strings between the two stacks are then forced to have non-zero length. They acquire a non-zero tension, and the quarks become massive.

Summary

In the high energy theory, a stack of N_f D5-branes intersecting a stack of N_c D3-branes gives a bifundamental quark transforming in the fundamental of $U(N_c)$ and the antifundamental of $U(N_f)$, and an anti-bifundamental quark transforming in the antifundamental of $U(N_c)$ and the fundamental of $U(N_f)$.

In the low energy theory, a stack of N_f D5-branes intersecting a stack of N_c D3-branes gives N_f massless quarks that transform in the fundamental rep of the $U(N_c)$ gauge group, and which have a $U(N_f)$ global flavour symmetry, as well as N_f massless anti-quarks that transform in the antifundamental rep of the $U(N_c)$ gauge group, and which also have a $U(N_f)$ global flavour symmetry.

To give the quarks non-zero mass, introduce a separation between the D3 and D5-branes, such that the D3-D5 (D5-D3) strings acquire non-zero tension.

6.3 A 3d Effective Field Theory from String Theory

The brane configurations of primary interest will be slight variations on the famous Hanany-Witten brane configurations introduced in [48]. It will prove instructive to build these brane configurations gradually, whilst explaining the physics at each stage.

6.3.1 An Infinite D3-brane

Consider a D3-brane extending to infinity in the (x_0, x_1, x_2, x_6) -directions [48]. The theory on its worldvolume is a $(1 + 3)$ d gauge theory. It can be shown that bosonic strings ending on the brane give rise to a groundstate tachyon, $(p + 1) - 2 = 3 + 1 - 2 = 2$ massless states corresponding to the independent transverse components of a vector boson, and $p + 1, \dots, D - 1$ scalars. When supersymmetry is added to this theory $D = 10$ becomes the critical dimension and there are six such scalar states. These scalars correspond to the fluctuations of the D3-brane in its transverse spatial directions $(x_3, x_4, x_5, x_7, x_8, x_9)$. The tachyon state is GSO projected out.

This bosonic spectrum is consistent with the bosons that appear in the on-shell vector multiplet of $(1 + 3)$ d $N = 4$ supersymmetry [49]. The vector multiplet contains a 4d gauge boson, three complex scalars, and four Majorana fermions [49]. The six real scalars of the string correspond to the three complex scalars of the multiplet. A single Dp -brane breaks supersymmetry from 32 supercharges to 16 supercharges by reducing the number of independent components of the supercharges. 16 supercharges correspond to $N = 4$ in 4d, so it is not surprising that the bosonic degrees of freedom match those of the 4d $N = 4$ vector multiplet. The fermionic superpartners of these bosons give the four Majorana fermions.

Summary:

An infinite D3-brane along (x_1, x_2, x_6) gives an on-shell 4d $N = 4$ (16 supercharge) on-shell vector multiplet, containing a 4d vector boson, three complex (six real) scalars, and four Majorana fermions.

6.3.2 A D3-brane Between two NS5-branes

Two NS5-branes are taken to extend in $(x_1, x_2, x_3, x_4, x_5)$ and are separated by a finite distance along x_6 . The D3-brane is taken to extend infinitely along (x_1, x_2) and finitely along x_6 . The D3 brane extends from one NS5-brane to the other, along the finite x_6 -separation.

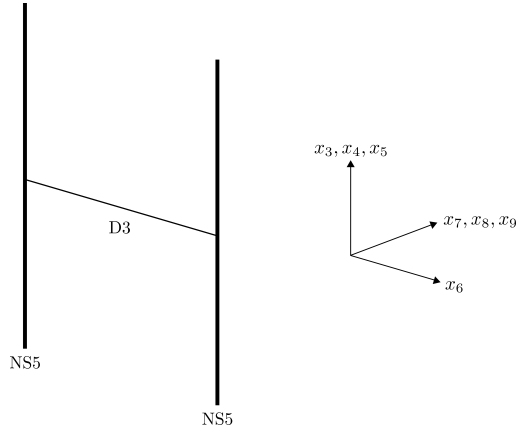

Figure 4: A D3-brane between two NS5-branes. The spatial directions x_3, x_4 and x_5 , that the D3 and NS5-branes have in common, could not be drawn, but they exist. As will be the case with later diagrams, only those dimensions that clearly indicate the relative orientations of the branes are drawn.

The x_6 part of the D3-brane can be taken to be small, such that there exists a $(1+2)$ d low energy field theory rather than a $(1+3)$ d one on the worldvolume. This can be treated as a dimensional reduction. The $(1+3)$ d vector boson becomes a scalar b , and a $(1+2)$ d vector boson a_μ , where $\mu = 0, 1, 2$ [48]. The scalar ‘ b ’ satisfies[48]:

$$\partial_\mu b = F_{\mu 6} \tag{6.3}$$

The boundary conditions at the D3-D5 boundary affect the spectrum of states [48]. For a D3-brane ending on an NS5-brane, the end of the D3-brane creates a boundary in (x_0, x_1, x_2) , the dimensions that the D3 and NS5-branes have in common. The x_6 -direction of the D3-brane is normal to this boundary.

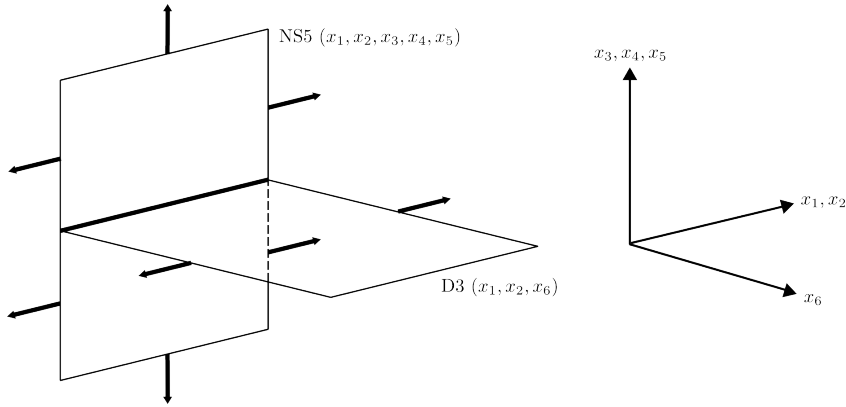

Figure 5: Only the relevant spatial dimensions are represented. The arrows represent those directions in which the branes extend to infinity. The D3-brane is finite in x_3 with both ends ending on NS5-branes. In the diagram above only one of these NS5-branes is drawn for clarity. The D3-D5 boundary is represented by the thick black line (which is actually infinite in (x_1, x_2)).

The D3-brane is restricted by Dirichlet boundary conditions in the directions (x_6, x_7, x_8, x_9) [48]. These are the directions, along which, the NS5-brane stops the D3-brane from fluctuating. Six scalars on the D3-brane correspond to fluctuations of the D3-brane in its transverse spatial directions $(x_3, x_4, x_5, x_7, x_8, x_9)$. The D3-brane ending on the NS5 results in three of these scalars, corresponding to (x_7, x_8, x_9) , being restricted by Dirichlet boundary conditions and disappearing. On the other hand, the scalars corresponding to (x_3, x_4, x_5) are subject to Neumann boundary conditions and survive.

How about the vector boson? Consider the 4d vector boson A_ξ (here $\xi = 0, 1, 2, 6$, is used in place of $\mu = 0, 1, 2$) [48]. The corresponding field strength is given by $F_{\xi\rho}$. The NS5-branes impose a Neumann boundary condition on $F_{\xi\rho}$. The effect of this is that those components of $F_{\xi\rho}$, where one index corresponds to one of the boundary directions, become zero. The boundary runs along (x_0, x_1, x_2) , so, the result is that $F_{\mu,6} = 0$, $\mu = 0, 1, 2$. Using equation 6.3 this means that Neumann boundary conditions give $b = 0$.

So, for the D3-brane between NS5-branes, the field b and the (x_7, x_8, x_9) scalars disappear.

Supercharge analysis shows that the D3-brane between two NS5-branes preserves eight supercharges, corresponding to $N = 2$ in $(1 + 3)d$, and to $N = 4$ in $(1 + 2)d$. So, to start with, a 16 supercharge $(1 + 3)d$ theory was considered on the infinite D3-brane worldvolume. Then, by having the D3-brane shortened in the x_6 and ending on NS5-branes, this supersymmetry was broken to eight supercharges and dimensional reduction occurred ($(1 + 3)d \rightarrow (1 + 2)d$). Now consider the $(1 + 3)d$ on-shell $N = 4$ (16 supercharge) vector multiplet which contains a $(1 + 3)d$ gauge boson, three complex scalars, and four Majorana fermions, which corresponded to the infinite D3-brane worldvolume theory $((1 + 3)d)$. Dimensional reduction to an $N = 8$ 3d (also 16 supercharge) theory would give an on-shell vector multiplet containing a 3d vector boson, seven real scalars and eight Majorana fermions. This corresponds to the spectrum of the finite D3-brane *before* the boundary conditions at the D3-NS5 intersections were considered; there was a gauge boson a_μ and a scalar b , as well as six scalars corresponding to fluctuations in $(x_3, x_4, x_5, x_7, x_8, x_9)$ (see above). Now this $N = 8$ on-shell vector multiplet decomposes into a vector multiplet and a hypermultiplet under the $N = 4$ subalgebra [48]. The $N = 4$ on-shell vector multiplet consists of a $(1 + 2)d$ vector field, three real scalars and four Majorana fermions. The hypermultiplet consists of four real scalars and four Majorana fermions. The $(1 + 2)d$ $N = 8$ theory can be broken to the $(1 + 2)d$ $N = 4$ theory by imposing that either the $N = 4$ vector multiplet or the $N = 4$ hypermultiplet disappears (it would be impossible to form the $N = 8$ multiplet with either missing). a_μ and the (x_3, x_4, x_5) scalars are assigned to the bosonic part of the $(1 + 2)d$ on-shell $N = 4$ vector multiplet,

whilst b and the (x_7, x_8, x_9) scalars are assigned to the bosonic part of the $(1+2)$ d on-shell $N = 4$ hypermultiplet. Above it was explained that b and the (x_7, x_8, x_9) scalars disappear when the D3-brane is made to end on NS5-branes. Therefore the hypermultiplet disappears, leaving a $(1+2)$ d on-shell $N = 4$ vector multiplet.

Gauge Coupling

The coupling of the ‘electric’⁹ $U(N_c)$ gauge group associated with N_c D3s between the two NS5s is given by [48, 50]:

$$g_e^2 = \frac{g_s}{|t_1 - t_2|} \quad (6.4)$$

where g_s is the string coupling and t_1 and t_2 are the positions of the NS5s along x_6 .

Summary:

A finite D3-brane along (x_1, x_2, x_6) between two NS5-branes (each along $(x_1, x_2, x_3, x_4, x_5)$) gives, in the low energy limit, an on-shell 3d $N = 4$ (eight supercharge) vector multiplet containing a vector a_μ , three real scalars corresponding to the fluctuations of the brane along (x_3, x_4, x_5) and four Majorana fermions.

The coupling of the gauge group associated with the D3s is:

$$g_e^2 = \frac{g_s}{|t_1 - t_2|} \quad (6.5)$$

where t_1 and t_2 are the positions of the NS5s in x_6 .

6.3.3 A D3-brane Between two D5-branes

Now consider two D5-branes extending in $(x_1, x_2, x_7, x_8, x_9)$ and separated by some finite distance in the x_6 -direction. Take a D3-brane to extend infinitely in (x_1, x_2) and finitely in x_6 , with each end on the separated D5s.

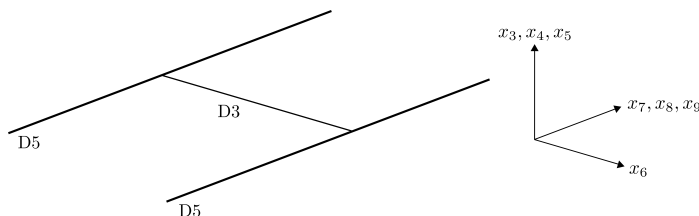

Figure 6: A D3-brane between two NS5-branes.

⁹Associated with this ‘electric’ theory is a ‘magnetic’ theory which is mentioned in the next section. The electric and magnetic theories are duals of each other, as discussed in [48].

As with the NS5-D3-brane configuration of the previous section, the x_6 part of the D3-brane can be taken to be small, such that there exists a $(1 + 2)$ d low energy theory. The $(1 + 3)$ d vector boson becomes a scalar b , and a 3d vector boson a_μ , where $\mu = 0, 1, 2$ [48]. The scalar ‘ b ’ satisfies equation 6.3.

As before, the boundary conditions affect the spectrum of states [48]. For a D3-brane ending on an D5-brane, the end of the D3-brane creates a boundary in (x_0, x_1, x_2) , the dimensions that the D3 and D5-branes have in common. The x_6 -direction of the D3-brane is normal to this boundary.

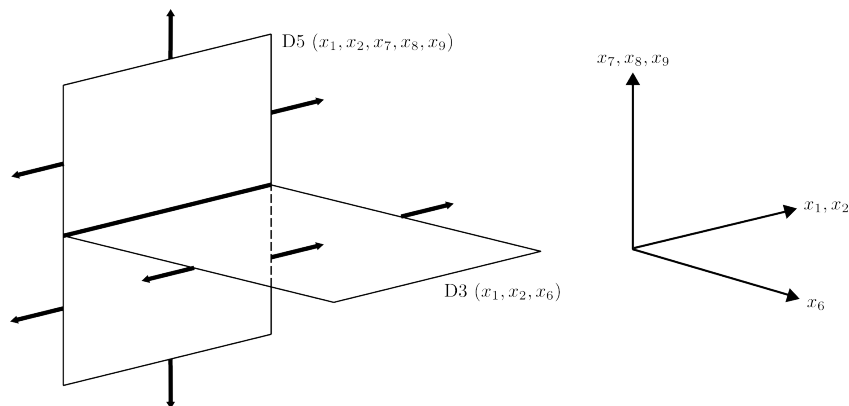

Figure 7: Only the relevant spatial dimensions are represented. The arrows represent those directions in which the branes extend to infinity. The D3-brane is finite in x_3 with both ends ending on NS5-branes. In the diagram above only one of these NS5-branes is drawn for clarity. The D3-D5 boundary is represented by the thick black line (which is actually infinite in (x_1, x_2)).

This time the D5-brane stops the D3-brane from fluctuating in the (x_3, x_4, x_5) -directions, so, of the six scalars of the infinite D3-brane associated with $(x_3, x_4, x_5, x_7, x_8, x_9)$, those associated with fluctuations along (x_3, x_4, x_5) have Dirichlet boundary conditions and vanish. Those associated with fluctuations along (x_7, x_8, x_9) have Neumann boundary conditions and survive.

The D5-branes impose a Dirichlet boundary condition on the $(1 + 3)$ d gauge boson, where the components of $F_{\xi\rho}$ with both indices taking values in $\xi, \rho = 0, 1, 2$ become zero (e.g $F_{02} = 0$) [48]. The result is that:

$$F_{\mu\nu} = 0 \tag{6.6}$$

where $\mu, \nu = 0, 1, 2$. This field strength is associated with the 3d gauge boson a_μ mentioned above, so the result is that a_μ disappears.

Ending the D3-brane on two D5-branes causes the 3d gauge boson a_μ and the scalars associated with fluctuations along (x_3, x_4, x_5) to disappear [48]. These are the bosonic

degrees of freedom associated with the aforementioned $(1 + 2)$ d on-shell $N = 4$ (8 supercharge) vector multiplet. The surviving degrees of freedom are b and the scalars associated with fluctuations along (x_7, x_8, x_9) . These are the bosonic degrees of freedom of the aforementioned $(1 + 2)$ d on-shell $N = 4$ (8 supercharge) hypermultiplet.

Gauge Coupling

The coupling of the ‘magnetic’ $U(N_c)$ gauge group associated with N_c D3s between the two D5s is given by [48]:

$$g_m^2 = \frac{g_s}{|z_1 - z_2|} \quad (6.7)$$

where g_s is the string coupling and z_1 and z_2 are the positions of the NS5s along x_6 .

Summary:

A finite D3-brane along (x_1, x_2, x_6) between two D5-branes (each along $(x_1, x_2, x_7, x_8, x_9)$) gives, in the low energy limit, a 3d on-shell $N = 4$ (eight supercharge) hypermultiplet containing a scalar b , three scalars corresponding to the fluctuations of the brane along (x_7, x_8, x_9) and four Majorana fermions.

The coupling of the gauge group associated with the D3s is:

$$g_m^2 = \frac{g_s}{|z_1 - z_2|} \quad (6.8)$$

where z_1 and z_2 are the positions of the D5s in x_6 .

D3-branes ending on D5-branes are not considered in the remainder of this text, and were mentioned for completeness.

6.3.4 A D3-brane between an NS5-brane and a D5-brane

Consider a D5-brane extending in $(x_1, x_2, x_7, x_8, x_9)$ and an NS5-brane extending in $(x_1, x_2, x_3, x_4, x_5)$, separated by some finite distance in the x_6 -direction. Take a D3-brane to extend infinitely in (x_1, x_2) and finitely in x_6 , with each end on the separated five-branes.

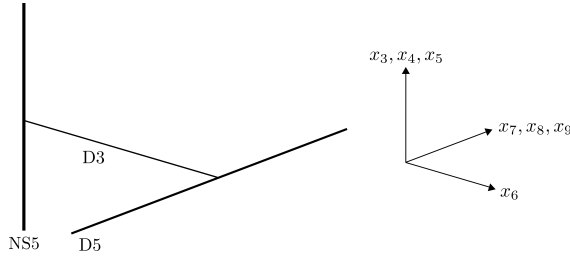

Figure 8: A D3-brane between an NS5-brane and a D5-brane.

By combining the conditions for D3-branes between NS5-branes and the conditions for D3-branes between D5-branes, it is clear that all the scalars corresponding to the fluctuations of the D3-brane in the $(x_3, x_4, x_5, x_7, x_8, x_9)$ -directions disappear [48]. The fields a_μ and b also vanish, so the low energy theory has no massless states.

The main purpose of mentioning this brane configuration is to make it clear that it does not give an interesting spectrum of states.

6.3.5 A D3-brane between two NS5-branes and Intersected by a D5-Brane

Now consider two NS5-branes extending in $(x_1, x_2, x_3, x_4, x_5)$ and separated by some finite distance in the x_6 -direction. A D3-brane is taken to extend infinitely in (x_1, x_2) and finitely in x_6 , with each end on each NS5-brane, respectively. In addition, consider a D5-brane extending along $(x_1, x_2, x_7, x_8, x_9)$ intersecting the D3-brane at some point along x_6 between the two NS5-branes. Note that this is not a configuration where a D3-brane *ends* on the D5-brane; the D3-D5 boundary conditions are not employed.

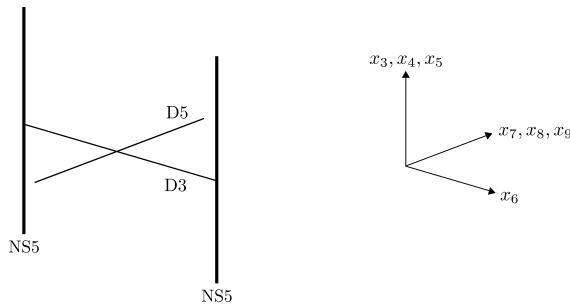

Figure 9: A D3-brane between two NS5-branes, with a D5-brane intersecting the D3-brane.

In section 6.3.2 it was shown, using boundary conditions, that the D3-brane between the two NS5-branes give rise to a $(1+2)d$ $N = 4$ vector multiplet containing a $(1+2)d$ vector a_μ ($\mu = 0, 1, 2$), three scalars corresponding to fluctuations of the brane along (x_3, x_4, x_5) and four Majorana fermions.

The inclusion of D5-branes does not break supersymmetry any further. D5-branes along $(x_1, x_2, x_7, x_8, x_9)$ and NS5-branes along $(x_1, x_2, x_3, x_4, x_5)$ give an eight

supercharge theory. The supercharge analysis shows that D3-branes extending in (x_1, x_2, x_6) can be added with no further supersymmetry breaking. That is, the supercharge relation for such a D3-brane arises automatically from a combination of the D5 and NS5 supercharge relations. This could be seen another way: the NS5-brane and D3-brane Killing spinor relations imply the D5-brane Killing spinor relation. Therefore the current configuration of a D3-brane between NS5-branes with a D5-brane intersecting the D3-brane preserves the same supersymmetry as the case of the D3-brane between two NS5-branes considered in section 6.3.2. Eight supercharges corresponds to $N = 4$ in $(1 + 2)d$.

In section 6.2 analysis of the Chan-Paton factors revealed that massless quark flavours arise from D5-branes intersecting D3-branes. Therefore, with supersymmetry included, the D3-D5 intersection should give rise to hypermultiplets. Note that, in the cases above, brane boundary conditions were considered because D3-branes were considered that were *ending* on either NS5-branes or D5-branes. However, in this case, the D3-brane is *intersecting* the D5-brane, so there are no Dirichlet conditions imposed on the D3 from the D5. Since the brane configuration preserves 8 supercharges corresponding to $N = 4$ in 3d, the on-shell hypermultiplet arising from the D3-D5 string is the 3d on-shell $N = 4$ hypermultiplet consisting of four real scalars and four Majorana spinors.

As well as this, due to the D3-brane ending on two NS5-branes, the D3-D3 strings give rise to the vector multiplet of section 6.3.2.

Summary:

The configuration contains two NS5-branes extending in $(x_1, x_2, x_3, x_4, x_5)$ and separated by some finite distance in the x_6 -direction. A D3-brane is taken to extend infinitely in (x_1, x_2) and finitely in x_6 , with each end on each NS5-brane, respectively. In addition, a D5-brane extending along $(x_1, x_2, x_7, x_8, x_9)$ intersects the D3-brane at some point along x_6 between the two NS5-branes.

The D3-D3 strings give rise to a low energy $(1 + 2)d$ on-shell $N = 4$ (eight supercharge) vector multiplet containing a vector a_μ ($\mu = 0, 1, 2$), three scalars corresponding to fluctuations of the D3-brane along (x_3, x_4, x_5) , and four Majorana fermions.

The D3-D5 strings give rise to a low energy $(1 + 2)d$ on-shell $N = 4$ (eight supercharge) hypermultiplet containing four real scalars, and four Majorana fermions.

6.3.6 Rotating the Left Hand NS5-brane

Consider starting from the brane configuration of the previous section. Then rotate one of the NS5-branes (say the left hand one) from its original orientation along $(x_1, x_2, x_3, x_4, x_5)$ to $(x_1, x_2, x_3, x_8, x_9)$. The rotated brane is written with a dash (NS5'-brane) to distinguish it from the non-rotated NS5-brane. Supercharge analysis shows that this breaks SUSY from eight supercharges to four.

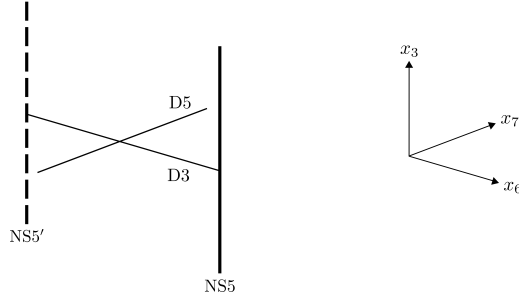

Figure 10: A D3-brane between an NS5-brane and an NS5'-brane, with a D5-brane intersecting the D3-brane.

Before the NS5-brane was rotated, the configuration was shown to contain a $(1+2)$ d on-shell $N = 4$ (eight supercharge) vector multiplet (see the previous section). Under $(1+2)$ d $N = 2$ (four supercharges) supersymmetry this vector multiplet decomposes into a vector multiplet and an adjoint chiral multiplet. The on-shell $(1+2)$ d $N = 2$ vector multiplet contains a vector field a_μ , a real scalar field and a Dirac fermion. The on-shell $(1+2)$ d $N = 2$ chiral multiplet contains two real scalar fields and two Majorana fermions. The off-shell $(1+2)$ d $N = 2$ supermultiplets can also be considered. The off-shell vector multiplet contains a $(1+2)$ d vector, a real scalar, a Dirac fermion (two complex components), and an auxiliary real scalar D-field [51, 52, 53]. The off-shell chiral multiplet contains a complex scalar, a Dirac fermion (two complex components), and an auxiliary complex scalar F-field [51, 52, 53].

When SUSY is broken, by rotating the left hand NS5-brane, one of these 3d $N = 2$ supermultiplets disappears from the low energy theory. Specifically the adjoint chiral multiplet becomes massive. The $(1+2)$ d $N = 2$ vector and adjoint multiplets that make up the $(1+2)$ d $N = 4$ vector multiplet are required to have the same mass in order for $N = 4$ SUSY to be preserved. By making the $N = 2$ adjoint chiral multiplet massive, and leaving the $N = 2$ vector multiplet massless, the $N = 4$ SUSY is broken to $N = 2$.

Define the complex planes [38, 54]:

$$v = x_4 + ix_5 \tag{6.9}$$

$$w = x_8 + ix_9 \tag{6.10}$$

Using this description the NS5-brane extends along v and exists at $w = 0$, whilst the NS5'-brane extends along w and exists at $v = 0$. A rotation of the left NS5-brane, from its original $(x_1, x_2, x_3, x_4, x_5)$ position, corresponds to [38, 54]:

$$(v, w) \rightarrow (v_\theta, w_\theta) \tag{6.11}$$

where:

$$\begin{aligned} v_\theta &= v\cos(\theta) + w\sin(\theta) \\ w_\theta &= -v\sin(\theta) + w\cos(\theta) \end{aligned} \tag{6.12}$$

The angle θ determines whether SUSY is broken or not. θ equal to multiples of 2π radians (including 0 radians) corresponds to unbroken SUSY (8 supercharges), whilst other angles correspond to broken SUSY (to 4 supercharges).

The pre-rotation NS5-brane is chosen to be located at $w = 0$. The NS5-brane rotated through an angle θ , exists at $w_\theta = 0$. Using equation 6.12, the rotated NS5-brane gives [38, 54]:

$$\begin{aligned} -v\sin(\theta) + w\cos(\theta) &= 0 \\ \Rightarrow w &= \tan(\theta)v \end{aligned} \tag{6.13}$$

The rotation of the brane is continuous, so it should not be surprising that the brane angle corresponds to the some sort of continuous physical parameter [38, 54]. Since the pre-rotated NS5-brane preserves the scalars of the $(1 + 2)d$ $N = 2$ (4 supercharge) adjoint chiral multiplet, and since the NS5'-brane eliminates these scalars, it is fitting to write the adjoint chiral multiplet mass as:

$$\mu = \tan(\theta) \tag{6.14}$$

When $\theta = 0$ the NS5-brane extends along $(x_1, x_2, x_3, x_4, x_5)$ and the adjoint chiral multiplet, and its scalars, are massless. This preserves the 3d $N = 4$ (8 supercharge) theory. On the other hand, $\theta = \pi/2$ corresponds to the NS5'-brane running along $(x_1, x_2, x_3, x_8, x_9)$. The adjoint chiral multiplet, and its scalars, have infinite mass, and SUSY is broken to $(1 + 2)d$ $N = 2$ (4 supercharges) [38, 54]. The adjoint chiral multiplets are integrated out when considering the low energy $(1 + 2)d$ theory.

With SUSY now reduced to $(1+2)d$ $N=2$ the D3-D5 strings give rise to a low energy $(1+2)d$ on-shell $N=2$ chiral multiplet containing two real scalars, and two Majorana fermions.

The configuration consisting of NS5-branes along $(x_1, x_2, x_3, x_4, x_5)$ and D3-branes along (x_1, x_2, x_6) gives a $(1+2)d$ $N=4$ (eight supercharges) vector multiplet.

Rotating one of the NS5-branes by an angle θ in the $(x_4, x_5) - (x_8, x_9)$ plane gives a mass of $\mu = \tan(\theta)$ to the $(1+2)d$ $N=2$ adjoint chiral multiplet, thereby reducing SUSY to $(1+2)d$ $N=2$ (four supercharges).

The D3-D5 strings give rise to a low energy $(1+2)d$ on-shell $N=2$ chiral containing two real scalars, and two Majorana fermions.

6.3.7 Introducing Massive matter by Introducing a D3-brane D5-brane Separation - The Naive Approach

The configuration considered in the last section was that of a D3-brane between an NS5-brane and an NS5'-brane, with a D5-brane intersecting the D3-brane. Consider the same configuration with N_c D3-branes and N_f D5-branes:

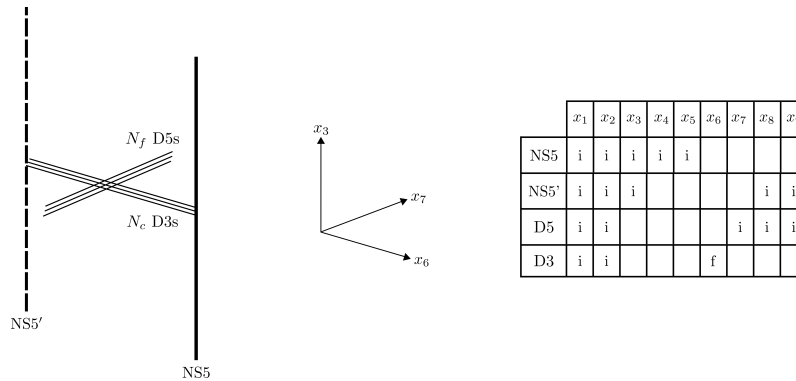

Figure 11: The brane configuration that gives rise to a $(1+2)d$ four supercharge $U(N_c)$ effective field theory containing N_f massless flavours. In the table the i's correspond to those directions in which a brane extends infinitely. The f in the table indicates that the D3-branes extend finitely in the x_6 -direction.

In order to introduce massive matter, a gap needs to be introduced between D3 and D5-branes, such that they no longer intersect. The result of this is that the D3-D5 (D5-D3) strings become stretched and acquire non-zero tension, thereby giving mass to the groundstates in their spectrum. The most obvious way to introduce a D3-brane D5-brane gap would be to simply move the D5-branes away from the D3-branes in

either the x_3 , x_4 or x_5 -directions [55]. The displacement in the x_3 -direction corresponds to a real mass for the quarks, whilst a displacement in the x_4 and x_5 -directions corresponds to a complex mass for the quarks. The real mass is given by the ‘vector mass’ m_V mentioned in section 4.6 [37]. The complex mass corresponds to Lagrangian density term:

$$\int d^2\theta m_c Q \tilde{Q} \quad (6.15)$$

mentioned in equation 4.2.

How about the axial mass m_A that was mentioned in section 4.6? This can be understood by considering the D5-branes moving to the left along x_6 until they intersect the NS5'-brane [37]. They can then split into two halves, with one half displaced upwards in the x_3 -direction, and the other displaced the same distance in the opposite direction. Consider the (naive) picture below:

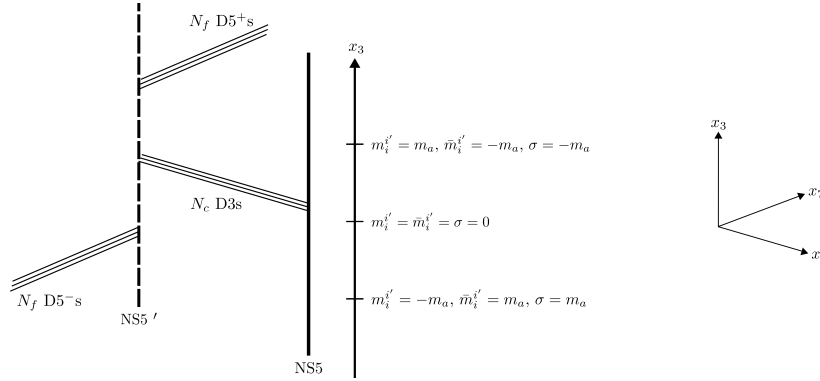

Figure 12: A naive method for splitting the D5-brane in two on the NS5'-brane.

Recall that, for general N_c and general N_f , the semiclassical scalar potential is minimised by imposing:

$$\left(\delta_j^{j'} m_i^{i'} + \sigma_j^{j'} \delta_i^{i'} \right) \phi^{i,j} = 0 \quad (6.16)$$

$$\left(\delta_j^{j'} \tilde{m}_i^{i'} - \sigma_j^{j'} \delta_i^{i'} \right) \tilde{\phi}^{i,j} = 0 \quad (6.17)$$

The N_c D3-brane positions determine the N_c values of the diagonal of $\sigma_j^{j'}$. The above diagram gives $\sigma_1^1 = \sigma_2^2 = \dots = \sigma_{N_c}^{N_c} = 0$. The positions of the D5⁺-branes correspond to the values of the diagonal matrix $m_i^{i'}$. In this case those values are $m_1^1 = m_2^2 = \dots = m_{N_f}^{N_f} = m_a$. The positions of the D5⁻-branes correspond to the values of the diagonal matrix $\tilde{m}_i^{i'}$. In this case those values are

$\tilde{m}_1^1 = \tilde{m}_2^2 = \dots = \tilde{m}_{N_f}^{N_f} = m_a$. The result is N_f flavours of quark with mass m and N_f flavours of anti-quark with mass m_a . Note that, in order for the above equations to be satisfied, all components of ϕ and $\tilde{\phi}$ must be zero.

6.3.8 Brane Deformations and the (p, q) -web

Unfortunately, the brane configuration in figure 12 considered above is not correct. The reason for this is that, when one fivebrane ends on another fivebrane, the branes are deformed; they do not meet at convenient right angles [56].

The D5-brane ending on the NS5-brane

The D5-brane extends in the $(x_1, x_2, x_7, x_8, x_9)$ -directions, and the NS5'-brane that it ends on extends in the $(x_1, x_2, x_3, x_8, x_9)$ -directions [55]. The D5 and NS5'-branes can be imagined as deforming one another at the point of intersection. Before including this deformation the picture looks like:

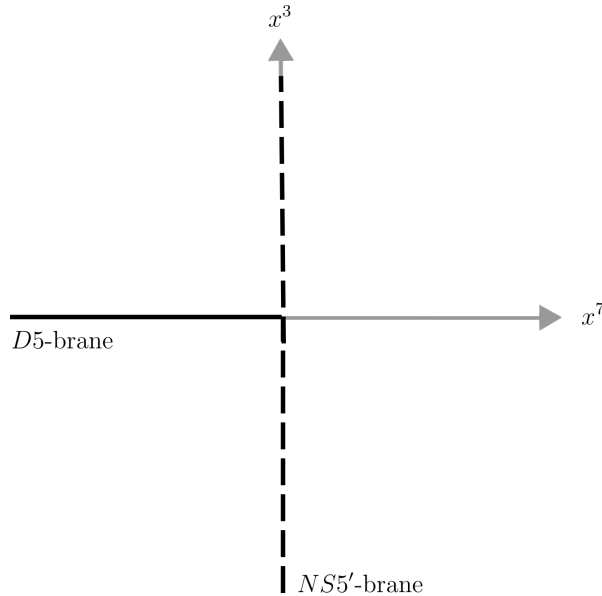

Figure 13: The NS5'-brane and D5-brane intersection before deformations are accounted for.

The NS5'-brane has four transverse directions (x_4, x_5, x_6, x_7) . The x_7 -direction is the only transverse direction of the NS5'-brane that the D5-brane extends along. Similarly the D5-brane has the transverse directions (x_3, x_4, x_5, x_6) , out of which the NS5-brane extends along x_3 . As a result, it is expected that the x_3 position of the NS5'-brane depends on the x_7 position of the D5-brane. x_7 can be written as a function of x_3 , where the function is required to minimize the worldvolume of the NS5'-brane. For large x_3 the two positions of the branes are related by the one-dimensional Laplace equation [55]:

$$\nabla^2 x_7 = \delta(x_3) \quad (6.18)$$

The solution to this equation is [55]:

$$x_7 = \frac{1}{2}|x_3| + cx_3 + d \quad (6.19)$$

where c and d are constants. At large and negative x_3 the solution is expected to correspond to a the NS5'-brane located at $x_7 = 0$. With this in mind the constants are chosen to take the values $c = 1/2$ and $d = 0$. This gives:

$$x_7 = \frac{1}{2}|x_3| + \frac{1}{2}x_3 \quad (6.20)$$

Therefore, for a D5-brane ending on an NS5'-brane at $x_3 = x_7 = 0$, the configuration is drawn [55]:

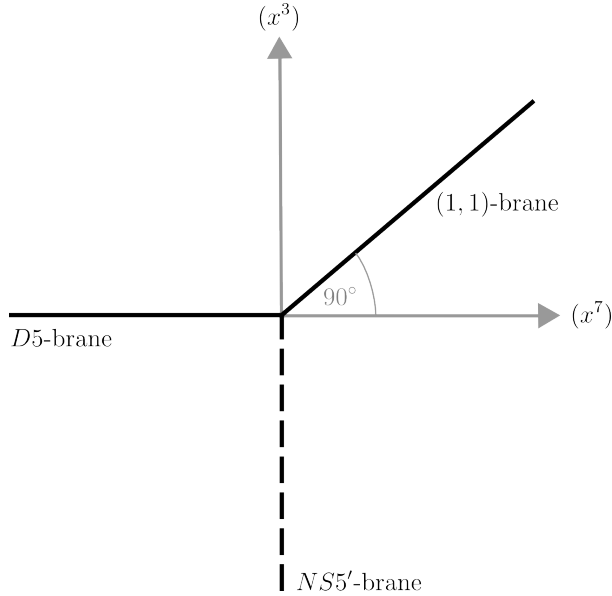

Figure 14: The NS5'-brane and D5-brane intersection results in a (1,1)-brane bound-state.

The diagonal brane is interpreted as a (1,1)-brane. A (1,1)-brane is a (p,q) -brane with $p = q = 1$, and a (p,q) -brane is a bound state of p NS5-branes and q D5-branes [55]. The (1,1)-brane is required to extend at 90° in the (x_3, x_7) plane in order for supersymmetry not to be broken. It also extends along (x_1, x_2, x_8, x_9) . In general a (p,q) -brane must be oriented at an angle θ where [55]:

$$\tan(\theta) = p/q \quad (6.21)$$

in order to preserve supersymmetry.

It is clear that the brane configuration in figure 12 is not drawn accurately. The D5-branes should actually split along the NS5-brane as in the diagram below [37]:

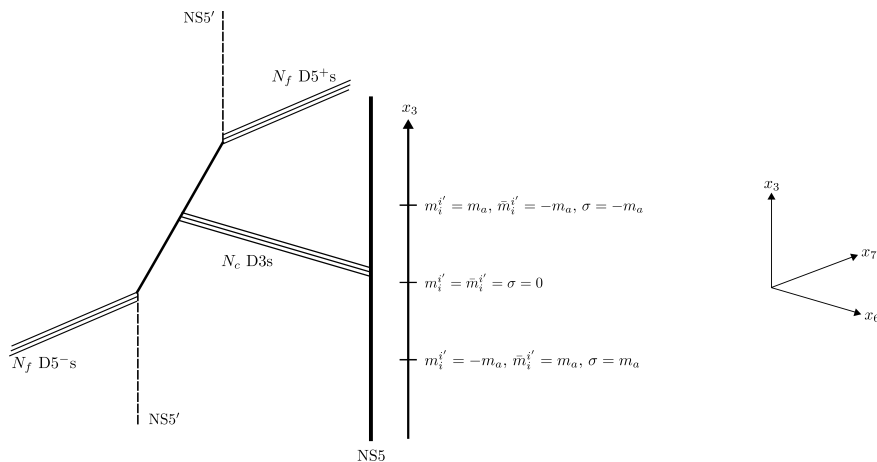

Figure 15: The correct splitting of D5-branes on the NS5'-brane.

The (p, q) -brane extends at an angle $\theta = \tan^{-1}(1/N_f)$ in the (x_3, x_7) plane, and also extends along (x_1, x_2, x_8, x_9) .

Note that not all of the D5-branes need be split as above. An arbitrary number of the N_f D5-branes can be formed in to the NS5'-D5- (p, q) 'web', whilst the remaining can be left in their original position intersecting the D3-branes.

The Bare FI-term from NS5-brane Separations in (x_7, x_8, x_9)

The Fayet-Iliopoulos D-term coefficient ζ is given by the separation of the NS5-branes in the (x_7, x_8, x_9) -directions [48]:

$$\vec{\zeta} = \vec{w}_1 - \vec{w}_2 \quad (6.22)$$

Here w_1 and w_2 are the (x_7, x_8, x_9) positions of the two NS5-branes. The FI-term is associated with the center of the $U(1) \in U(N_c)$ of the gauge group $U(N_c)$ that arises from D3-D3 strings. In this case the (p, q) -web introduces a displacement of the two halves of the NS5'-branes in the x_7 -direction. The top NS5'-brane moves to positive x_7 whilst the bottom one moves to negative x_7 . The result is that the bare value of ζ associated with the $U(N_c)$ group is given by the difference in x_7 positions of the two NS5'-branes. This is the same ζ that appears in equation 4.4, and in subsequent equations in section 4. The value of this coupling in the effective theory is then adjusted by integrating out massive matter, according to equation 4.15.

This FI-term ζ is actually mirror dual to the mass term that corresponds to the D5-brane position in x_3 . The mirror dual of an NS5-brane extending along $(x_1, x_2, x_3, x_4, x_5)$ and at position $(x_7, x_8, x_9) = (a, b, c)$ is a D5-brane extending along $(x_1, x_2, x_7, x_8, x_9)$ and at position $(x_3, x_4, x_5) = (a, b, c)$. As well as exchanging NS5-branes with D5-branes, the duality exchanges the (x_3, x_4, x_5) positions with (x_7, x_8, x_9) . The D5-brane position in (x_3, x_4, x_5) corresponds to mass terms for the fundamental hypermultiplet associated with NS5-D3 strings. Therefore mirror symmetry also corresponds to $\vec{m} \leftrightarrow \vec{\zeta}$ [34, 57]. The (p, q) -web gives rise to D5s displaced in x_3 . This displacement corresponds to the real mass m found in the background vector multiplet (see equation 4.2). The mirror dual is an NS5-brane displaced in x_7 , corresponding to a real FI parameter ζ [35].

D3-branes ending on Fivebranes

When considering brane deformations, the situation is different for a D3-brane ending on a fivebrane [56]. Consider the D3-brane ending on the NS5'-brane: The D3-brane extends along (x_1, x_2, x_6) whilst the NS5'-brane extends along $(x_1, x_2, x_3, x_8, x_9)$. The NS5'-brane has one transverse direction x_6 that the D3-brane extends in, whilst the D3-brane has three transverse directions (x_3, x_8, x_9) which the NS5'-brane extends in. As a result the x_6 position of the NS5'-brane is dependent on (x_3, x_8, x_9) , and the resulting Laplacian is 3d. Such a solution to the Laplacian gives a constant as $x_3, x_8, x_9 \rightarrow \infty$. This constant just corresponds to the NS5'-brane position and the brane is not drawn any differently. The same reasoning applies to the NS5-brane. The NS5-brane extends along the $(x_1, x_2, x_3, x_4, x_5)$. This has a transverse direction x_6 that the D3-brane extends along, whilst the D3-brane has the transverse directions (x_3, x_4, x_5) that the NS5-brane extends along. Again, this results in a 3d Laplacian and the position of the NS5-brane is just a constant at large (x_3, x_4, x_5) . Finally, the D5-brane extends along $(x_1, x_2, x_7, x_8, x_9)$. This has a transverse direction x_6 that the D3-brane extends along, whilst the D3-brane has the transverse directions (x_7, x_8, x_9) that the D5-brane extends along. So, again, the D5-brane position is just a constant at large (x_7, x_8, x_9) and the brane is not drawn any differently.

6.3.9 A D3-brane between the (p, q) -brane and the NS5-brane

Consider D3-branes with one end at any point along the (p, q) -brane and one end on the NS5-brane, as in figure 15.

Mass Term for the Vector Multiplet from (p, q) -brane Angle

In section 6.3.6 it was explained that rotating the NS5-brane to give the NS5'-brane means suppressing the x_4 and x_5 fluctuations of the D3-brane. This corresponds to making the $(1 + 2)d$ $N = 2$ adjoint chiral multiplet infinitely massive (the two real scalars in this multiplet correspond to the x_4 and x_5 positions of the D3-brane). A

similar process occurs when the (p, q) -brane is introduced. Before the creation of the (p, q) -brane, the D3-brane was free to fluctuate in the x_3 -direction. The (p, q) -brane restricts fluctuation in this direction, in the same way that an NS5-brane at an angle in the (x_4x_5, x_8x_9) plane restricts fluctuation in the x_4 and x_5 -directions [41]. x_3 fluctuations correspond to the real scalar of the 3d $N = 2$ vector multiplet, and so the D3-branes between the (p, q) -brane and the NS5-brane results in this scalar becoming massive. However, the configuration preserves SUSY, and so all the fields in the 3d $N = 2$ vector multiplet must acquire the same mass [41]. Take the angle of the (p, q) -brane to be that between the (p, q) -brane and the x_3 axis:

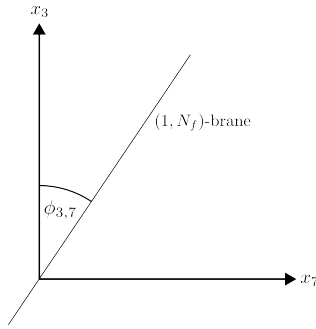

Figure 16: The angle of the $(1, N_f)$ -brane in the x_3, x_7 plane.

The vector multiplet mass μ_V is proportional to the angle, $\phi_{3,7}$ of a (p, q) -brane as:

$$\mu_V = \tan(\phi_{3,7}) \quad (6.23)$$

Above it was mentioned that, in order to preserve SUSY, the angle of the (p, q) -brane in the (x_3, x_7) plane is related to the number of NS5-branes, p , and the number of D5-branes, q , by [55]:

$$\tan(\phi_{3,7}) = \frac{p}{q} \quad (6.24)$$

Hence:

$$\mu_V = \frac{p}{q} \quad (6.25)$$

Making the vector multiplet massive would usually result in a breaking of the gauge symmetry in the effective theory. However in $(1 + 2)$ d the gauge symmetry can be preserved by using Chern-Simons terms in the Lagrangian [41, 58].

The Bare Chern-Simons Level from (p, q) -brane Angle

The angle $\phi_{3,7}$ of the (p, q) -brane also determines the bare Chern-Simons level k associated with the gauge group of D3s ending on it [37, 41, 58, 59]:

$$k = \frac{p}{q} = \tan(\phi_{3,7}) \quad (6.26)$$

The second equality is required to preserve supersymmetry. Comparing with equations 6.24 and 6.25 shows that k is equal to the mass of the $(1 + 2)d$ $N = 2$ vector multiplet associated with gauge groups of D3s between the (p, q) -brane and the NS5-brane. As stated in equation 4.14 and explained in section 5, the bare CS-level is subject to adjustment from further factors that are obtained by integrating out massive matter.

Displaced D3-branes

It is not only the D5-branes that can be displaced, the D3-branes can be moved up or down along the (p, q) -brane. However, since the ends of the (p, q) -branes are displaced in the x_7 -direction, the D3-branes cannot end further up or further down the (p, q) -brane *and* end on the NS5-brane without existing at an angle in the (x_6, x_7) plane. This is shown in the configuration on the left in the figure below:

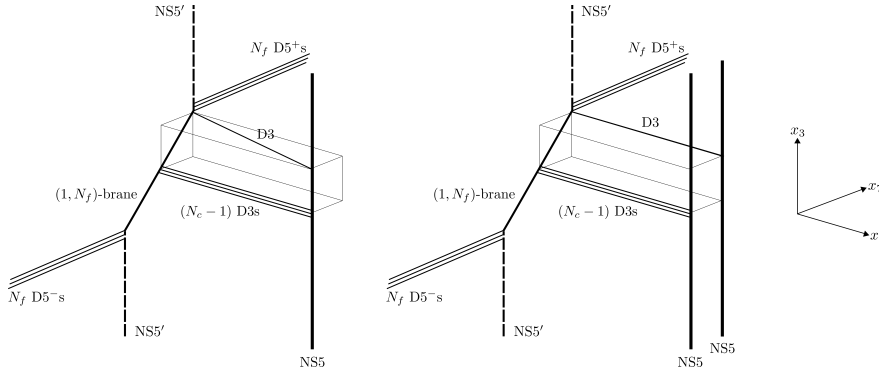

Figure 17: On the left is the configuration for a displaced D3-brane ending on the NS5', D5⁺, $(1, N_f)$ intersection, and on the NS5-brane. This D3 is at an angle in the (x_6, x_7) plane and breaks supersymmetry. Note that the hexahedron drawn with thin lines which extend in the (x_3, x_6, x_7) -directions does not represent a configuration of branes, but is simply there to make the orientation of the D3-brane in the (x_6, x_7) plane easier to see. On the right hand side is the configuration which preserves supersymmetry. A new NS5-brane is introduced so that the displaced D3-brane extends along the x_6 -direction, as required.

The D3-brane is required to extend along the (x_1, x_2, x_6) -directions in order for $(1 + 2)d$ $N = 2$ supersymmetry to be preserved; an orientation along any other direction breaks supersymmetry. As a result, in order to preserve SUSY, the D3-brane still needs to extend along (x_1, x_2, x_6) even in its displaced position. To

solve this a second NS5-brane (extending along $(x_1, x_2, x_3, x_4, x_5)$) is introduced, which is displaced in x_7 as far as the left-most end of the D3-brane, and which allows the D3-brane to extend along (x_1, x_2, x_6) , as on the right hand diagram in the above figure.

7 Strong-Weak Dualities in 4d and 3d Field Theories

Strong-weak duality (or ‘S-duality’) initially arose in the form of the electromagnetic duality of classical electrodynamics together with quantum considerations (the Dirac quantisation condition). It was then shown that S-duality could be generalised to a variety of non-abelian and/or supersymmetric theories. Two generalisations which are of central importance to this text are the Aharony and Giveon-Kutasov dualities of $(1 + 2)d$ $N = 2$ field theory. In this section a (very) brief overview of the different dualities will be presented, along with a description of the Aharony and Giveon-Kutasov dualities.

7.1 Electromagnetic Duality

7.1.1 Classical EM Duality

For a region with no electric or magnetic charges, Maxwell’s equations are given by [60]:

$$\vec{\partial} \cdot \vec{E} = 0 \tag{7.1}$$

$$\vec{\partial} \times \vec{E} = -\frac{\partial \vec{B}}{\partial t} \tag{7.2}$$

$$\vec{\partial} \cdot \vec{B} = 0 \tag{7.3}$$

$$\vec{\partial} \times \vec{B} = \frac{\partial \vec{E}}{\partial t} \tag{7.4}$$

where natural units are used. It is clear that these equations are invariant under the electromagnetic duality transformations [60]:

$$\vec{E} \rightarrow -\vec{B} \quad \vec{B} \rightarrow \vec{E} \tag{7.5}$$

The above Maxwell’s equations can be written in manifestly Lorentz invariant form as [60]:

$$\partial_\nu F^{\mu\nu} = 0 \tag{7.6}$$

$$\partial_\nu \star F^{\mu\nu} = 0 \tag{7.7}$$

Here $\star F^{\mu\nu}$ denotes the Hodge dual of $F^{\mu\nu}$. In this case the electromagnetic duality transformation is given by:

$$F^{\mu\nu} \rightarrow \star F^{\mu\nu} \quad \star F^{\mu\nu} \rightarrow -F^{\mu\nu} \quad (7.8)$$

In order for electromagnetic duality to exist for the case with sources, both electric and magnetic charges are required [60]:

$$\partial_\nu F^{\mu\nu} = j^\mu \quad (7.9)$$

$$\partial_\nu \star F^{\mu\nu} = k^\mu \quad (7.10)$$

Now the electromagnetic duality transformations are given by [60]:

$$F^{\mu\nu} \rightarrow \star F^{\mu\nu} \quad \star F^{\mu\nu} \rightarrow -F^{\mu\nu} \quad (7.11)$$

$$j^\mu \rightarrow k^\mu \quad k^\mu \rightarrow -j^\mu \quad (7.12)$$

The magnetic monopole is said to be the electromagnetic dual of the electric monopole.

7.1.2 The Quantum Electromagnetic Duality as a Strong-Weak Duality

Note that, so far, electromagnetic duality is not a strong-weak duality (S-duality). Such dualities refer to the equivalence of the strongly coupled limit of one theory to the weakly coupled limit of another. However, it is possible to show that electromagnetic duality, supplemented with the Dirac quantisation condition gives rise to a strong-weak duality [61]. The Dirac quantisation condition relates the electric charge q with the magnetic charge g by [23, 24, 60, 61]:

$$g = \frac{4\pi\hbar n}{q} \quad n \in \mathbb{Z} \quad (7.13)$$

In natural units $\hbar = 1$. Under electromagnetic duality the electric and magnetic charges are exchanged; what ever value q was becomes the new value of g and visa versa [62]:

$$q \rightarrow g \quad g \rightarrow -q \quad (7.14)$$

The Dirac quantisation condition means that a theory with large q has small g . Under the duality transformation this gives a theory with large g and small q . This is interesting as the large q in the former theory cannot be studied perturbatively.

However, information about the former electric theory can be garnered by performing the duality transformation, and then investigating the dual electric theory (with small g) perturbatively.

As will be discussed, strong-weak dualities can be strange. Sometimes individual electric quanta (which are fundamental) are dual to composite (non-fundamental) magnetic charges [61].

7.1.3 Dirac Monopole (Dirac String)

Now there is a problem. The introduction of a magnetic charge means that the magnetic field has a non-zero divergence. This would mean that a magnetic field can no longer be described as the curl of A (as $B = \nabla \times A$). Undesirable results occur when this relation is abandoned.

To preserve the curl of magnetic field, Dirac proposed the ‘Dirac monopole’, also called the ‘Dirac String’. Classically, the Dirac monopole is indistinguishable from a semi-infinite and infinitesimally thin solenoid, hence the latter name [60, 63]. The end of the solenoid resembles the source of the magnetic field. Quantum mechanically such a solenoid generally exhibits an interference pattern, which would distinguish it from the magnetic monopole. The special case in which the interference pattern disappears corresponds to the Dirac quantisation condition (equation 7.13) being satisfied [60, 63]. Everywhere in space, except at points along the Dirac string, $B = \nabla \times A$ is satisfied. Since this is not the case along the solenoid (at the points corresponding to the solenoid, the potential A blows up [64]) the position of the Dirac string is subtracted from the spacetime manifold. This is sometimes called a ‘defect’.

7.2 Montonen-Olive Duality

Remarkably, electromagnetic duality can be generalised to Yang-Mills theories. An early attempt at generalising the electromagnetic duality to non-abelian gauge theories was made by Montonen and Olive, when they tried to argue that S-duality was a feature of the non-supersymmetric Georgi-Glashow model [60]. Whilst there were many promising features of this theory that suggested a duality, it eventually became clear that duality did not apply after all. To remedy the issues that were faced, the $N = 2$ supersymmetric Yang-Mills theory was considered next.

Unfortunately, the supermultiplet of the magnetic monopole did not contain a spin-1 state necessary for Montonen-Olive duality. Thus $N = 2$ supersymmetric Yang-Mills theory was also deemed unsuitable. Next Montonen-Olive duality was considered in the framework of $N = 4$ super-Yang-Mills. This theory successfully fulfills the criteria for Montonen-Olive duality. These models are described briefly below.

7.2.1 The Georgi-Glashow Theory

This duality was conjectured by Montonen and Olive in their paper [65]. The semiclassical Georgi-Glashow theory, saturating the BPS bound ¹⁰, contains the following spectrum [60, 66] (table copied from [60]):

Table 3: Particle Properties in the Georgi-Glashow Model

Particle	Mass	Electric Charge	Magnetic Charge	Spin
Photon	0	0	0	± 1
Higgs boson	0	0	0	0
W_{\pm} boson	aq	$\pm q$	0	1
M_{\pm} monopole	ag	0	$\pm g$	0

q is an electric charge, g is a magnetic charge and a is a complex parameter. The theory can also contain dyons - particles with both electric and magnetic charge. All particles in the spectrum have mass $a\sqrt{q^2 + g^2}$. It is clear that the theory is left invariant by the duality transformation [66]:

$$q \rightarrow g \quad g \rightarrow -q \tag{7.15}$$

provided that the W-boson is exchanged with the magnetic monopole. In the above ‘electric theory’ the W boson is a single elementary point particle, whilst the magnetic monopole is a topological soliton, made out of a collection of excitations [60, 66, 67, 68]. In the dual ‘magnetic’ theory, the W-boson becomes a soliton made of numerous excitations, whilst the magnetic monopole becomes a single elementary point particle. The single point particles have ‘Noetherian charge’ whilst the solitons have ‘topological charge’ [68]. Since the states saturate the BPS bound, the magnetic monopole is sometimes called a BPS monopole [69]. In fact the magnetic monopole is an example of a ’t Hooft-Polyakov magnetic monopole [60]. Since the Dirac quantisation condition still applies, the duality relates a theory with strong coupling to one with weak coupling (it is an S-duality).

Evidence for Duality:

1) The duality exchanges magnetic monopoles with W-bosons, so it is expected that the dual theories have similar interactions [66]. This is indeed the case: The monopole is not self-interacting, but a monopole and an anti-monopole do interact. Similarly,

¹⁰All particles in the spectrum have mass equal to the modulus of the central charge.

equal charge W-bosons don't interact whilst those with different charges do. The interactions have been shown to be identical [60].

2) The mass formula for all the particles (including the dyons) is given by [66]:

$$M = a\sqrt{q^2 + g^2} \tag{7.16}$$

This is clearly invariant under the duality transformation (equation 7.15).

3) The electromagnetic duality of the spectrum comes as no surprise since the BPS bound is left invariant under the duality, and since the above spectrum saturates this bound [60].

Unfortunately, there are features of the duality that bring into question its validity.

Evidence Against Duality

1) Generally BPS bounds and the mass formula change under renormalisation due to loop corrections [60, 66]. This can result in the BPS equation and the mass formula no longer being invariant under the duality transformation. Therefore, the spectrum, which saturates the bound, will no longer be left invariant under duality.

2) In the dual (magnetic) theory the magnetic monopoles play the role of gauge particles [60, 66]. They would then be expected to have spin 1, as opposed to spin 0. They need spin 1 in order to be dual to the W-bosons.

A better understanding of strongly coupled physics is required to investigate the loop corrections and determine the validity of the duality. In order to avoid the problems mentioned above, the duality can be reformulated in a supersymmetric theory [60]. The bosonic and fermionic renormalisation contributions cancel, avoiding renormalisation of the mass formula [66]. Also, the correct supersymmetric theory provides a spin-1 't Hooft Polyakov monopole that could potentially play the role of a gauge particle in the magnetic theory.

7.2.2 The $N = 2$ super-Yang-Mills Theory

An attempt to realise a consistent strong-weak duality in a non-abelian gauge theory was made in [70]. The authors proposed a generalisation of the Montonen-Olive duality to $(1 + 3)d$ $N = 2$ super-Yang-Mills theory. Unfortunately the attempt was not successful.

The $N = 2$ super-Yang-Mills action is given by [66]:

$$\mathcal{L} = \frac{1}{e^2} \int d^2\theta d^2\bar{\theta} \bar{\Phi} e^{2V} \Phi - \text{Re} \left[\frac{i}{16\pi} \int d^2\theta \tau W^\alpha W_\alpha + \text{h.c.} \right] \quad (7.17)$$

This can be rewritten [66, 70]:

$$\mathcal{L} = \frac{1}{8\pi} \text{Im} \left[\tau \left(2 \int d^2\theta d^2\bar{\theta} \bar{\Phi} e^{2V} \Phi + \int d^2\theta W^\alpha W_\alpha \right) \right] \quad (7.18)$$

where [66, 70]:

$$\tau = \frac{\theta}{2\pi} + i \frac{4\pi}{e^2} \quad (7.19)$$

W^α is the superfield strength related to the $N = 2$ vector superfield V by [66, 71]:

$$W_\alpha = -\frac{1}{4} \bar{D}^2 D_\alpha V \quad (7.20)$$

Φ is the $N = 2$ adjoint chiral superfield [66].

The on-shell $N = 2$ vector superfield has the combined field content of the on-shell $(1 + 3)\text{d}$ $N = 1$ vector multiplet and the on-shell $(1 + 3)\text{d}$ $N = 1$ adjoint chiral multiplet [49, 71]. The former contains a gauge boson and a Majorana fermion, the latter contains a complex scalar and a Majorana fermion. The on-shell $N = 2$ adjoint chiral superfield contains the combined field content of a $(1 + 3)\text{d}$ $N = 1$ adjoint chiral multiplet (a complex scalar and a Majorana fermion) and a $(1 + 3)\text{d}$ $N = 1$ adjoint chiral multiplet in the conjugate representation (a complex scalar and a Majorana fermion, both in the conjugate representation) [49, 71].

The theory contains solitons that are dyons as well as 't Hooft-Polyakov magnetic monopoles, just like in the Georgi-Glashow model.

Semiclassical Results

The complex scalar ϕ of the adjoint chiral superfield Φ can be written in terms of real scalars A_4 and A_5 as [66]:

$$\phi = \frac{1}{\sqrt{2}} (A_5 + iA_4) \quad (7.21)$$

Take a_4 and a_5 to be the asymptotic values of A_4 and A_5 respectively [66]. Then define a to be the asymptotic value of ϕ :

$$a = \frac{1}{\sqrt{2}} (a_5 + ia_4) \quad (7.22)$$

The BPS bound is given by [66]:

$$M \geq \frac{a'}{e} \sqrt{q^2 + g^2} = \sqrt{2} \frac{|a|}{e} |q + ig| \quad (7.23)$$

where a' is simply related to a by [66]:

$$a' = \sqrt{2}|a| = |a_5 + ia_4| \quad (7.24)$$

Here, the relation $|q + ig|^2 = (q + ig)(q - ig) = q^2 + g^2 \rightarrow |q + ig| = \sqrt{q^2 + g^2}$ is used. Therefore BPS states saturating the bound have mass [66]:

$$M = \frac{a'}{e} \sqrt{q^2 + g^2} = \sqrt{2} \frac{|a|}{e} |q + ig| \quad (7.25)$$

The first equality shows that the mass is left invariant under the duality transformation of the charges. The electric charge is given by [66]:

$$q = n_e e \quad (7.26)$$

and the magnetic charge is given by:

$$g = \frac{4\pi}{e} n_m \quad (7.27)$$

where n_e and n_m are integers [66]. Introducing a θ angle via τ (see equation 7.19), the mass is then written:

$$M = \sqrt{2}|a||n_e + \tau n_m| \quad (7.28)$$

The BPS condition (the mass formula) of this theory can be derived as a result of the supersymmetry algebra [66]. Since the supersymmetry algebra is valid in both classical and quantum regimes, states that saturate the bound do not experience quantum correction to their mass. Naively, this would suggest that the mass formula is not subject to any change. Actually the parameter a , corresponding to the moduli space, is only accurate in the weakly coupled regime. In the strongly coupled regime the mass formula must be modified. Consequently, $N = 2$ SYM theory fails to keep a consistent mass formula in the strong regime and the strong-weak duality cannot apply.

In addition, the 't Hooft-Polyakov monopole is part of an $N = 2$ ‘BPS multiplet’ containing two spin-0 states and two spin- $\frac{1}{2}$ states [66]. The $(1 + 3)d$ $N = 2$ chiral multiplet contains four spin-0 states and four spin- $\frac{1}{2}$ states, and so it is made of two BPS multiplets. At most the monopole can have spin- $\frac{1}{2}$, where as spin-1 is required for duality with the gauge boson.

In summary, whilst the mass formula is free of quantum corrections, the a parameter found in the mass formula changes upon transition from the weak to the strong coupling regime. Furthermore, whilst the magnetic monopole has non-zero spin, the spin- $\frac{1}{2}$ it does have is insufficient to make it a magnetic dual of the gauge particle. The $N = 4$ super-Yang-Mills theory of the next section succeeds where the $N = 2$ theory fails.

7.2.3 The $N = 4$ super-Yang-Mills Theory

It was shown in the previous section that $N = 2$ SYM contains a mass formula that changes in transition between weak and strong coupling regimes. It was also shown that the magnetic monopoles didn’t have the same spin as the gauge fields. This prompted Osborn (see [72]) to consider $(1 + 3)d$ $N = 4$ super-Yang-Mills theory [66]. It was hoped that the greater amount of supersymmetry would give rise to spin-1 monopoles and that changes in the mass formula would not occur.

The $N = 4$ super-Yang-Mills Lagrangian density is given by [66]:

$$\begin{aligned} \mathcal{L} = & \frac{1}{e^2} \int d^2\theta d^2\bar{\theta} \sum_{i=1}^3 \bar{\Phi}_i e^{2V} \Phi_i + \frac{1}{8\pi} \text{Im} \left(\int d^2\theta \tau W^\alpha W_\alpha \right) \\ & - \left(\int d^2\theta \sqrt{2} \Phi_1 \Phi_2 \Phi_3 + h.c. \right) \end{aligned} \quad (7.29)$$

The above Lagrangian density is written in terms of the $(1 + 3)d$ $N = 2$ vector multiplet V and the $(1 + 3)d$ $N = 2$ chiral multiplet Φ . See the previous section for their field content.

As in the $N = 2$ SYM theory, for BPS saturated states, the SUSY algebra of the $N = 4$ SYM theory gives rise to the mass formula [66]:

$$\begin{aligned} M &= \frac{a'}{e} \sqrt{q^2 + g^2} \\ &= \sqrt{2} \frac{|a|}{e} |q + ig| \\ &= \sqrt{2} |a| |n_e + \tau n_m| \end{aligned} \quad (7.30)$$

As in the $N = 2$ SYM theory, this mass formula is not subject to renormalisation from loop contributions as the supersymmetry algebra holds true in both the classical and the quantum theories [66]. The parameter a is not subject to adjustment.

Furthermore, the W-bosons and the magnetic monopoles belong to supermultiplets with the same field content, and can therefore have the same spin [66]. The $N = 4$ supermultiplet containing the monopole consists of one spin-1 state, four spin- $\frac{1}{2}$ and five spin-0 states [66, 72]. The vector boson belongs in a short supermultiplet with the same fields. The supermultiplet of the monopole and the short supermultiplet of the gauge boson are isomorphic [60].

The evidence suggests the existence of an S-duality in $(1 + 3)d$ $N = 4$ SYM theory.

7.3 Seiberg Duality

In 1994 Seiberg proposed ([73]) a new type of S-duality in which the non-abelian S-duality is applied to $N = 1$ theories. The idea is that, at high energies, the electric and magnetic theories do not exhibit a duality. Instead the two theories flow to a common infra-red fixed point, exhibiting S-duality at low energies.

Consider a supersymmetric QCD theory, called SQCD. SQCD extends the concept of QCD with an $SU(3)$ gauge group, to include supersymmetry and a more general $SU(N_c)$ gauge group. The name ‘quark’ will refer to a field transforming in the fundamental of $SU(N_c)$ [73, 74].

7.3.1 S-Duality in the Conformal Window

The bound $\frac{3}{2}N_c < N_f < 3N_c$ is known as the ‘conformal window’ [74]. Call the SQCD with gauge group $SU(N_c)$ and flavour group $U(N_f)$ in the conformal window the electric theory. The conjectured magnetic dual of this theory is $SU(n_c)$ gauge theory with N_f flavours satisfying $n_c = N_f - N_c$. This duality was originally proposed by Seiberg in 1994 [73].

For the electric SQCD, denote the quarks as Q , the anti-quarks as \bar{Q} , and the meson ($Q\bar{Q}$ boundstate) as M [74]. Denote the quarks of the magnetic SQCD q , and denote the anti-quarks \bar{q} . The electric SQCD does not have a superpotential, whilst the magnetic SQCD has a superpotential [74]:

$$W_m \sim Mq\bar{q} \tag{7.31}$$

Here the subscript ‘ m ’ simply stands for ‘magnetic’. Note that the magnetic theory superpotential is written in terms of magnetic SQCD quarks and an electric SQCD meson. The electric and magnetic theories are only dual to each other at low energies,

where they flow to a common ‘Banks-Zaks fixed point’ [74]. Importantly the electric SQCD is asymptotically free, whilst the magnetic SQCD is IR free. The gauge groups of two dual theories need not match, but the global symmetries of one theory in the UV should match the global symmetry of the other theory in the IR. The global symmetries of the electric theory in the UV are (table copied from [74]):

Table 4: Global Symmetries of the Electric SQCD in the UV

Particle	$SU(N_c)$	$SU(N_f)$	$SU(N_f)$	$U(1)_B$	$U(1)_R$
Q	\square	\square	1	1	$\frac{N_f - N_c}{N_f}$
\bar{Q}	$\bar{\square}$	1	\square	-1	$\frac{N_f - N_c}{N_f}$

The global symmetries of the magnetic theory in the IR are (table copied from [74]):

Table 5: Global Symmetries of the Magnetic SQCD in the IR

Particle	$SU(N_c)$	$SU(N_f)$	$SU(N_f)$	$U(1)_B$	$U(1)_R$
q	\square	$\bar{\square}$	1	$\frac{N_c}{N_f - N_c}$	$\frac{N_c}{N_f}$
\bar{q}	$\bar{\square}$	1	$\bar{\square}$	$\frac{-N_c}{N_f - N_c}$	$\frac{N_c}{N_f}$
M	1	\square	\square	0	$2\frac{N_f - N_c}{N_f}$

The meson M is identified with the $Q\bar{Q}$ bound state, but only in the IR where the duality holds [74]. This can be seen from the canonical dimensions of the fields. In the UV the canonical dimension of the meson is 1 whilst that of the $Q\bar{Q}$ boundstate is 2. However, when a RG flow is made to the Bank-Zaks fixed point, these particles pick up anomolous dimensions which adjust both their canonical dimensions to $(3N_f - 3N_c)/N_f$. The UV meson M_m and the IR meson M are related by [74]:

$$M = Q\bar{Q} = \mu M_m \quad (7.32)$$

The superpotential of the magnetic SQCD can be rewritten [74]:

$$W_m = \frac{1}{\mu} M q \bar{q} \quad (7.33)$$

Just as in the $N = 2$ SYM theory, the holomorphic gauge coupling can be written [74]:

$$\tau = \frac{\theta}{2\pi} + i \frac{4\pi}{e^2} \quad (7.34)$$

where e is the electric coupling. This allows the ‘holomorphic dynamical scale’ to be defined as [74]:

$$\Lambda = \mu e^{i2\pi b/\tau} \quad (7.35)$$

The holomorphic scale of the electric theory is denoted Λ whilst that of the magnetic theory is denoted $\tilde{\Lambda}$. UV consideration of the electric theory and IR consideration of the magnetic theory relates these scales as [74]:

$$\Lambda^{3N_c - N_f} \tilde{\Lambda}^{3N_c - 2N_f} = (-1)^{N_f - N_c} \mu^{N_f} \quad (7.36)$$

The RHS of the above equation is a constant. Subsequently, as one holomorphic scale increases the other decreases. Then, as one theory becomes strongly coupled the other becomes weakly coupled [74].

Quantum Anomalies

An anomaly is a symmetry of a classical theory (for example a gauge symmetry) that does not extend to the corresponding quantum theory [75]. Mathematically, symmetries of the classical theory are those symmetries that leave the action invariant. Subsequently, the classical equations of motion are unchanged by the symmetry transformation. To say that the quantum theory is not invariant under the symmetry transformation is to say that the path integral is changed by the transformation. Since the action is left invariant under the transformation, the exponential of the action is also left invariant. This means that, in order for a quantum anomaly to exist, the only part of the path integral that can be left unchanged by the transformation is the integration measure. Therefore, the integration measure is the source of the quantum anomaly.

There are different types of quantum anomaly depending on the symmetry in question. Anomalies can occur for both global or local symmetries (e.g. gauge symmetries) of the theory. Anomalies can often be cancelled, such that the symmetry in question applies to both the classical and the quantum theory [76]. This is achieved by imposing extra constraints on the quantum theory. The exact constraints are theory and symmetry dependent, and need to be considered on a case by case basis.

’t Hooft Anomaly Matching

The 't Hooft anomaly matching condition claims that the anomaly of a given theory should be independent of energy scale. Subsequently, for theories with couplings that change with energy scale, the anomaly should be the same for all couplings. The idea was originally proposed by 't Hooft in 1980 (see [77]).

't Hooft's original reasoning went as follows [77, 78, 79]: Consider an SQCD with gauge group $SU(N_c)$ and with a large global symmetry group G_F . This global symmetry can be gauged (made to be a local symmetry) and, just like for global symmetries, there can be an associated anomaly. The anomaly is cancelled by adding matter fields (quarks), called 'spectators', that are not coupled to the $SU(N_c)$ boson (not charged under $SU(N_c)$) and which are arbitrarily weakly coupled to the vector boson associated with the now local G_F . Since the spectators do not transform under the $SU(N_c)$ group, they are unaffected by RG flows of the $SU(N_c)$ coupling associated with changes in scale (changes in energy). The spectators can also be taken to be weakly coupled to the G_F group at all energies. As such the spectators are unaffected by RG flow, and cancel the anomaly in the same way at all energies and at all couplings of the $SU(N_c)$ group. The conclusion drawn is that the anomaly is unchanged also; if it did change the behaviour of the spectators would need to change in order to compensate, but the spectators are known to have the same interactions at all scales.

't Hooft anomaly matching has become a useful criterion for assessing whether a given theory is a candidate for the low energy limit (high energy limit) of another high energy (low energy) theory [79]. If the anomalies of the two theories do not match then such a theory is not a candidate. This criterion, as evidence for such theories being different energy limits of the same overall theory, carries different weight depending on the theory. In many cases there are numerous candidates, all with the same anomalies and in this case 't Hooft anomaly matching does not single out one above the other. For the case of the SQCD with $SU(N_c)$ gauge group, 't Hooft anomaly matching is a particularly strong indicator of a link between the high and low energy limits [79].

Global Anomalies of the Electric and Magnetic Theories

Evidence for S-duality is given by the fact that the global anomalies of the electric and the magnetic theories are the same [74]. The global anomalies are gauged (made to be local symmetries) before the anomalies are calculated.

The anomalies are characterised by their 'anomaly coefficient' [80]. For a symmetry with generator T_a the coefficient is defined as:

$$A_{abc} = \text{Tr}(T_a\{T_b, T_c\}) \tag{7.37}$$

where $\{T_b, T_c\}$ is an anticommutator. The trace is over all colours and all flavours [80]. The current associated with the symmetry is related to A_{abc} by [80]:

$$\partial_\lambda J_a^\lambda = \frac{A_{abc}}{64\pi^2} \epsilon^{\mu\nu\alpha\beta} g F_{\mu\nu}^b g F_{\alpha\beta}^c \quad (7.38)$$

For a symmetry of the theory, the current is conserved and the right hand side equals zero. Subsequently, $A_{abc} \neq 0$ corresponds to a breaking of the symmetry [80]. Each of the three generators T_a , T_b and T_c can correspond to a different global symmetry. So, for example T_a can correspond to one of the $SU(N_f)$ symmetries, whilst T_b and T_c both correspond to $U(1)_B$. In this case one could say that A_{abc} is labelled by $SU(N_f) \times U(1)_B^2$. Note that there is only one $U(1)_B$ symmetry (see tables 4 and 5), but the associated generator emerges twice in this particular A_{abc} . A different anomaly coefficient A_{abc} can be written for all combinations of the symmetries.

The global anomalies of the electric and the magnetic theory are (table copied from [81]):

Table 6: Global Anomalies of the Electric and Magnetic $N = 1$ $U(N_c)$ SQCDs

Global Symmetry	Electric Anomaly	Magnetic Anomaly
$SU(N_f)^3$	$-(N_f - N_c) + N_f$	N_c
$U(1)_B \times SU(N_f)^2$	$\frac{N_c}{N_f - N_c}(N_f - N_c)\frac{1}{2}$	$\frac{N_c}{2}$
$U(1)_R \times SU(N_f)^2$	$\frac{N_c - N_f}{N_f}(N_f - N_c)\frac{1}{2}$ $+\frac{N_f - 2N_c}{N_f}N_f\frac{1}{2}$	$-\frac{N_c^2}{2N_f}$
$U(1)_B^3$	0	0
$U(1)_B$	0	0
$U(1)_B \times U(1)_R^2$	0	0
$U(1)_R$	$\frac{N_c - N_f}{N_f}2(N_f - N_c)N_f$ $+\frac{N_f - 2N_c}{N_f}N_f^2$ $+(N_f - N_c)^2 - 1$	$-N_c^2 - 1$
$U(1)_R^3$	$\left(\frac{N_c - N_f}{N_f}\right)^3 2(N_f - N_c)N_f$ $+\left(\frac{N_f - 2N_c}{N_f}\right)^3 N_f^2$ $+(N_f - N_c)^2 - 1$	$-2\frac{N_c^4}{N_f^2} + N_c^2 - 1$
$U(1)^2 \times U(1)_R$	$\left(\frac{N_c}{N_f - N_c}\right)^2 \frac{N_c - N_f}{N_f}$ $\times 2N_f(N_f - N_c)$	$-2N_c^2$

In the table above, a quick simplification of the expressions in the ‘Electric Anomaly’ column will show that each ‘Electric Anomaly’ entry matches the corresponding ‘Magnetic Anomaly’ entry along the same row. Therefore the anomalies associated with global symmetries of the electric and magnetic theories match.

Matching of the Moduli Spaces

Further evidence for duality is provided by the matching of the moduli spaces of the electric and magnetic theories [74]. This can be seen by examining the baryons and mesons of the electric theory as well as those of the magnetic theory.

Square of the Duality Transformation

Another check for the duality is to see if the duality transformations applied twice returns the original theory [74]. For example, beginning with the electric theory, the duality transformation gives the magnetic theory, then a further application of the duality transformation should return the original electric theory. It can be shown that taking the dual of the dual of the electric theory returns the original scaling of the electric theory as well as the original particle content. For example taking the dual gives the superpotential that appears in the magnetic theory, then taking the dual again allows this superpotential to be set to zero.

7.4 Aharony Duality

Seiberg duality can be generalised to $(1 + 2)$ -dimensional field theories. The type of duality that is obtained depends on whether Chern-Simons terms are included or not. For theories without such terms, the duality obtained is called ‘Aharony duality’ (see [2] for the original paper).

The electric theory is a $(1 + 2)$ d $N = 2$ $U(N_c)$ gauge theory with N_f chiral multiplets Q_i in the \mathbf{N}_c representation and N_f anti-chiral multiplets $\bar{Q}_{\bar{i}}$ in the $\overline{\mathbf{N}}_c$ representation, where $i, \bar{i} = 1, \dots, N_f$ [2]. The Higgs branch is parameterised by mesons:

$$M_i^{\bar{i}} = Q_i \bar{Q}_{\bar{i}} \tag{7.39}$$

which are gauge singlets (gauge invariant) under $U(N_c)$ [34, 2, 82]. The Coulomb branch is parameterised by the chiral superfield monopole operators [2, 82, 83]:

$$V_+ \sim e^{\Sigma/g^2} \tag{7.40}$$

$$V_- \sim e^{-\Sigma/g^2} \tag{7.41}$$

where $\Sigma = \sigma + i\gamma$. σ is the real scalar belonging to the $(1 + 2)$ d $N = 2$ vector multiplet, γ is the scalar dual of the gauge boson that exists in the $(1 + 2)$ d $N = 2$ vector multiplet [82]. Such a duality between the scalar and the vector field is unique to $(1 + 2)$ -dimensions, and is not part of the S-duality currently being explained. Finally, g is the coupling of the gauge group [82].

The global symmetries, after quantum corrections, are given by (table copied from [2]):

Table 7: Global Symmetries of Electric SQCD

Particle	$U(1)_J$	$SU(N_f)$	$SU(N_f)$	$U(1)_A$	$U(1)_R$
Q	0	N_f	1	1	0
\bar{Q}	0	1	\bar{N}_f	1	0
M	0	N_f	\bar{N}_f	2	0
V_+	+1	1	1	$-N_f$	$N_f - N_c + 1$
V_-	-1	1	1	$-N_f$	$N_f - N_c + 1$

The magnetic dual theory is $(1 + 2)$ -dimensional $N = 2 U(N_f - N_c)$ with N_f flavours of quark q_i in the $\mathbf{N}_f - \mathbf{N}_c$ representation of $U(N_f - N_c)$ and N_f flavours of anti-quark \bar{q}^i in the $\overline{\mathbf{N}_f - \mathbf{N}_c}$ representation. Note that the magnetic gauge group is $U(N_f - N_c)$, the same as in the $(1 + 3)$ d Seiberg duality described in the previous section.

The global symmetries after quantum corrections are given by (table copied from [2]):

Table 8: Global Symmetries of Magnetic SQCD

Particle	$U(1)_J$	$SU(N_f)$	$SU(N_f)$	$U(1)_A$	$U(1)_R$
q	0	\bar{N}_f	1	-1	1
\bar{q}	0	1	N_f	-1	1
M	0	N_f	\bar{N}_f	2	0
\tilde{V}_+	+1	1	1	N_f	$N_f - N_c + 1$
\tilde{V}_-	-1	1	1	N_f	$N_f - N_c + 1$

Here \tilde{V}_+ and \tilde{V}_- are the Coulomb branch parameters of the dual theory (the monopole operators of the magnetic theory) [2, 83]. The M , V_+ and V_- field of the electric theory are gauge singlets under the $U(N_f - N_c)$ group of the magnetic theory [2]. In the magnetic theory M is interpreted as a fundamental field, whilst, in the electric theory, it is a composite of Q and \bar{Q} . A magnetic theory meson ($q\bar{q}$) can be considered as well, however it does not appear in the electric theory.

As was the case for S-duality in $(1 + 3)$ -dimensions, the magnetic theory contains a superpotential. In this case it is given by [2]:

$$W = M_i^{\bar{j}} q^i \bar{q}_{\bar{j}} + V_+ \tilde{V}_- + V_- \tilde{V}_+ \quad (7.42)$$

The presence of the monopole operators in the superpotential (and so, in the Lagrangian) is a weird feature of the magnetic dual theory.

Tests of Aharony Duality:

The dual of the dual gives the original theory [2].

The moduli spaces of the electric and magnetic theories match [2].

Matching of the global symmetries [2].

Matching of the partition functions of electric and magnetic theories with non-zero real masses and non-zero FI-terms [83, 84].

Matching of the superconformal index [83, 85].

7.4.1 Aharony Duality with Adjoint Matter

Aharony duality was also formulated for the case of $(1 + 2)\text{d } N = 2$ field theory containing adjoint matter [86].

As before, the electric theory is a $(1 + 2)\text{d } N = 2$ $U(N_c)$ gauge theory with N_f chiral multiplets Q_i in the \mathbf{N}_c representation and N_f anti-chiral multiplets $\bar{Q}_{\bar{i}}$ in the $\overline{\mathbf{N}}_c$ representation, where $i, \bar{i} = 1, \dots, N_f$ [86]. There are also the monopole operators V_+ and V_- , and M is composite field (meson). In addition there is the adjoint chiral multiplet Φ .

The electric theory contains the superpotential [86]:

$$W_e = \sum_{i=0}^n \frac{c_i}{n+1-i} \text{Tr} (\Phi^{n+1-i}) \quad (7.43)$$

With the inclusion of adjoint matter, the magnetic dual theory is a $(1 + 2)\text{d } N = 2$ theory with a $U(nN_f - N_c)$ gauge group [86]. The magnetic theory contains chiral multiplets q_i in the $\mathbf{nN}_f - \mathbf{N}_c$ representation and anti-chiral multiplets \bar{q}_i in the $\overline{\mathbf{nN}_f - \mathbf{N}_c}$ representation. There are also the monopole operators \bar{V}_+ and \bar{V}_- , and M is a fundamental field. In addition, there is an adjoint multiplet $\bar{\Phi}$. The magnetic theory includes a superpotential [86]:

$$W_m = \text{Tr} \bar{\Phi}^{n+1} + \sum_{j=0}^{n-1} M_j \bar{q} \bar{\Phi}^{n-1-j} q + \sum_{i=0}^{n-1} (V_{+,i} \bar{V}_{-,n+1-i} + V_{-,i} \bar{V}_{+,n-1-i}) \quad (7.44)$$

As before, this is an IR duality for zero Chern-Simons level ($k = 0$).

7.5 Giveon-Kutasov Duality

For theories with non-zero Chern-Simons level the S-duality is called a ‘Giveon-Kutasov duality (see [3] for the original paper). The electric theory is a $(1+2)\text{d } N=2$ $U(N_c)_k$ gauge theory with N_f chiral multiplets Q_i in the \mathbf{N}_c representation and N_f anti-chiral multiplets $\bar{Q}_{\bar{i}}$ in the $\overline{\mathbf{N}}_c$ representation, where $i, \bar{i} = 1, \dots, N_f$. Here the subscript k denotes the Chern-Simons level.

The global symmetries are $SU(N_f) \times SU(N_f) \times U(1)_A \times U(1)_R \times U(1)_J$ [3]. As was the case in the discussion of Aharony duality, the Higgs branch of the Giveon-Kutasov duality is parameterised by the meson:

$$M_{\bar{i}}^i = Q_i \bar{Q}_{\bar{i}} \quad (7.45)$$

and the Coulomb branch is parameterised by the chiral superfield monopole operators [83]:

$$V_+ \sim e^{\Sigma/g^2} \quad (7.46)$$

$$V_- \sim e^{-\Sigma/g^2} \quad (7.47)$$

where, again, $\Sigma = \sigma + i\gamma$.

The fields of the electric theory transform under the same global symmetries as the electric theory of Aharony duality (table copied from [87]):

Table 9: Global Symmetries of Electric SQCD

Particle	$U(1)_J$	$SU(N_f)$	$SU(N_f)$	$U(1)_A$	$U(1)_R$
Q	0	N_f	1	1	0
\bar{Q}	0	1	\overline{N}_f	1	0
M	0	N_f	\overline{N}_f	2	0
V_+	+1	1	1	$-N_f$	$N_f - N_c + 1$
V_-	-1	1	1	$-N_f$	$N_f - N_c + 1$

The magnetic dual theory is $(1+2)$ -dimensional $N=2$ $U(N_f + |k| - N_c)_{-k}$ with N_f flavours of quark q_i in the $\mathbf{N}_f + \mathbf{k} - \mathbf{N}_c$ representation of $U(N_f + |k| - N_c)$ and N_f flavours of anti-quark $\bar{q}^{\bar{i}}$ in the $\overline{\mathbf{N}}_f + |\mathbf{k}| - \overline{\mathbf{N}}_c$ representation [3]. The Coulomb

branch is parameterised by \tilde{V}_+ and \tilde{V}_- , which are singlets under $U(N_f + |k| - N_c)_{-k}$. In the magnetic theory M is interpreted as a fundamental field, whilst in the electric theory it is a composite of Q and \bar{Q} .

The fields of the magnetic theory transform under the same global symmetries as the magnetic theory of Aharony duality (table copied from [87] and using [2]):

Table 10: Global Symmetries of Magnetic SQCD

Particle	$U(1)_J$	$SU(N_f)$	$SU(N_f)$	$U(1)_A$	$U(1)_R$
q	0	\bar{N}_f	1	-1	1
\bar{q}	0	1	N_f	-1	1
M	0	N_f	\bar{N}_f	2	0
\tilde{V}_+	+1	1	1	N_f	$N_f - N_c + 1$
\tilde{V}_-	-1	1	1	N_f	$N_f - N_c + 1$

Unlike Aharony duality, Giveon-Kutasov duality does not contain monopole operators in the superpotential of the magnetic theory:

$$W = Mq\bar{q} \tag{7.48}$$

Tests of Giveon-Kutasov Duality:

The dual of the dual gives the original theory.

The moduli spaces of the electric and magnetic theories match [3].

Matching of the global symmetries.

Matching of the partition functions of electric and magnetic theories with non-zero real masses and non-zero FI-terms [84].

7.5.1 Giveon-Kutasov Duality with Adjoint Matter

Aharony duality was also formulated for the case of $(1+2)d$ $N=2$ field theory containing adjoint matter [41, 42].

As before, the electric theory is a $(1+2)d$ $N=2$ $U(N_c)$ gauge theory with N_f chiral multiplets Q_i in the \mathbf{N}_c representation and N_f anti-chiral multiplets $\bar{Q}_{\bar{i}}$ in the $\bar{\mathbf{N}}_c$ representation, where $i, \bar{i} = 1, \dots, N_f$. There are also the monopole operators V_+ and V_- , and M is composite field (meson). In addition there is the adjoint chiral multiplet Φ [41, 42].

The electric theory contains the superpotential [41, 42]:

$$W_e = \sum_{i=0}^n \frac{c_i}{n+1-i} \Phi^{n+1-i} \quad (7.49)$$

With the inclusion of adjoint matter, the magnetic dual theory is a $(1+2)\text{d } N=2$ theory with a $U(nN_f + n|k| - N_c)$ gauge group [41, 42]. Here n is the integer that appeared in section 4.7. The magnetic theory contains chiral multiplets q_i in the $\mathbf{nN_f} + \mathbf{n|k|} - \mathbf{N_c}$ representation and anti-chiral multiplets \bar{q}_i in the $\overline{\mathbf{nN_f} + \mathbf{n|k|} - \mathbf{N_c}}$ representation. There are also the monopole operators \bar{V}_+ and \bar{V}_- , and M is a fundamental field. In addition, there is an adjoint multiplet $\bar{\Phi}$.

The magnetic theory contains a superpotential which is absent of monopole operators [41, 42]:

$$W_m = - \sum_{i=0}^n \frac{\bar{c}_i}{n+1-i} \text{Tr} \bar{\Phi}^{n+1-i} + \sum_{i=1}^n \bar{c}_i M_i \bar{q}_i \bar{\Phi}^{n-i} q \quad (7.50)$$

\bar{c}_i and $\bar{\bar{c}}_i$ are functions of c_i . Alternatively this can be written [41, 42]:

$$W_m = - \frac{c_0}{n+1} \text{Tr} \bar{\Phi}^{n+1} + \sum_{i=1}^n M_i \bar{q}_i \bar{\Phi}^{n-i} q \quad (7.51)$$

As before, this is an IR duality for $k \neq 0$.

Part III

Results

8 Theories with Massive Fundamental and Antifundamental Matter

In [4], configurations of the form of the right hand diagram in 17 are considered, with various numbers of D5-branes and D3-branes displaced along the x_3 -direction. When a D5-brane is displaced, it becomes part of a (p, q) -NS5-D5-web; one half of the brane is displaced in the positive x_3 -direction and labelled as $D5^+$, whilst the other half is displaced in the negative x_3 -direction and labelled as $D5^-$. When a D3-brane is displaced, the whole brane is moved either in the positive x_3 -direction or in the negative x_3 -direction. In this section a variety of such configurations are considered. The massive and massless states that arise from these configurations are found. The induced Chern-Simons terms that arise in the low energy theory are determined, and the resulting flows between Aharony and Giveon-Kutasov dualities are stated.

Notation: Throughout this section all i indices (including those with dashes) are flavour indices. All j, k, l, m, n, p, q indices (including those with dashes) are colour indices.

8.1 One Displaced Flavour Brane

Consider the simplest non-trivial case first: Out of the N_f D5-branes, take the N_f^{th} D5-brane to be displaced along the x_3 -direction. The D5-brane splits into two parts, with a $D5^+$ at $x_3 = m$ and a $D5^-$ at $x_3 = -m$. These positions correspond to $m_{N_f}^{N_f} = m$ and $\tilde{m}_{N_f}^{N_f} = m$ respectively. It is then possible to look at a number of cases, corresponding to different numbers of D3-branes displaced along the x_3 in either the positive or negative direction.

8.1.1 No Displaced D3-branes

For the case of one displaced D5-brane, the simplest possibility for the D3-branes is to have none displaced in the x_3 -direction. This case will be explained in detail, then, for brevity, future sections will only display the results: The D5-branes labelled by the flavour indices $1, \dots, N_f - 1$ are at $x_3 = 0$, corresponding to $m_1^1, m_2^2, \dots, m_{N_f-1}^{N_f-1} = \tilde{m}_1^1, \tilde{m}_2^2, \dots, \tilde{m}_{N_f-1}^{N_f-1} = 0$. The N_f^{th} D5-brane is displaced and split into a $D5^+$ at $x_3 = m$ and a $D5^-$ at $x_3 = -m$, corresponding to $m_{N_f}^{N_f} = \tilde{m}_{N_f}^{N_f} = m$. The D3-branes labelled by the colour indices $1, \dots, N_c$ are at $x_3 = 0$, corresponding to $\sigma_1^1, \sigma_2^2, \dots, \sigma_{N_c}^{N_c} = 0$. The configuration is given by:

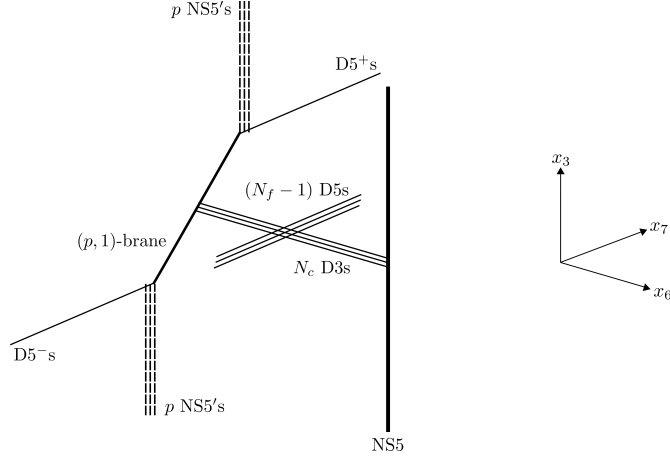

Recall that the following equations (4.51 and 4.52) need to be satisfied:

$$\left(\delta_j^{j'} m_i^{i'} + \sigma_j^{j'} \delta_i^{i'} \right) \phi^{i,j} = 0 \quad (8.1)$$

$$\left(\delta_j^{j'} \tilde{m}_i^{i'} - \sigma_j^{j'} \delta_i^{i'} \right) \tilde{\phi}^{i,j} = 0 \quad (8.2)$$

where q_i are chosen to equal one for all $i = 1, \dots, N_f$, where m , \tilde{m} and σ are diagonal matrices (they are only non-zero when their lower and upper indices match), and where $j, j' = 1, \dots, N_c$. The scalars of the chiral and anti-chiral multiplet are set to zero ($\phi^{i,j} = \tilde{\phi}^{i,j} = 0$). Subsequently, $\sigma_j^{j'}$, $m_i^{i'}$ and $\tilde{m}_i^{i'}$ can take any value, and the positions of the D3-branes and D5-branes are unrestricted. In this case all $\sigma_j^{j'}$ equal zero, m_i^i and \tilde{m}_i^i equal zero for $i = 1, \dots, N_f - 1$, and m_i^i and \tilde{m}_i^i equal m for $i = N_f$.

The mass terms of the chiral (matter) multiplets are given by:

$$\begin{aligned} V_{sc} \ni & \sum_{i=1}^{N_f} \bar{\phi}_i (m_i + \sigma \delta_i)^2 \phi_i + \sum_{i=1}^{N_f} \bar{\tilde{\phi}}_i (\tilde{m}_i - \sigma \delta_i)^2 \tilde{\phi}_i \\ & = \bar{\phi}_{i'',j''} \left(\delta_{j'}^{j''} m_{i'}^{i''} + \sigma_{j'}^{j''} \delta_{i'}^{i''} \right) \left(\delta_j^{j'} m_i^{i'} + \sigma_j^{j'} \delta_i^{i'} \right) \phi^{i,j} \\ & + \bar{\tilde{\phi}}_{i'',j''} \left(\delta_{j'}^{j''} \tilde{m}_{i'}^{i''} - \sigma_{j'}^{j''} \delta_{i'}^{i''} \right) \left(\delta_j^{j'} \tilde{m}_i^{i'} - \sigma_j^{j'} \delta_i^{i'} \right) \tilde{\phi}^{i,j} \end{aligned} \quad (8.3)$$

where $i, i', i'' = 1, \dots, N_f$ and where $j, j', j'' = 1, \dots, N_c$. Consider, first, the $N_f - 1$ D5-branes. It is expected that the zero length strings between them and the D3-brane stack will give rise to $N_f - 1$ flavours of massless matter. Indeed, $m = \tilde{m} = 0$ and $\sigma = 0$ for the flavours $1, \dots, N_f - 1$. Subsequently, there are $N_f - 1$ flavours of massless matter and antimatter transforming in the fundamental and antifundamental of $U(N_c)$.

The N_f^{th} flavour corresponds to the $D5^+$ and the $D5^-$ branes in the above diagram. The $D5^+$ position corresponds to $m_{N_f}^{N_f} = m$ and the $D5^-$ position corresponds to $\tilde{m}_{N_f}^{N_f} = m$. These give the mass terms:

$$V_{sc} \ni \bar{\phi}_{N_f, j''} \left(\delta_{j'}^{j''} m + (0) \delta_{j'}^{j''} \right) \left(\delta_j^{j'} m + (0) \delta_j^{j'} \right) \phi^{N_f, j} \quad (8.4)$$

$$V_{sc} \ni \bar{\tilde{\phi}}_{N_f, j''} \left(\delta_{j'}^{j''} m - (0) \delta_{j'}^{j''} \right) \left(\delta_j^{j'} m - (0) \delta_j^{j'} \right) \tilde{\phi}^{N_f, j} \quad (8.5)$$

This corresponds to a flavour of matter and antimatter with mass m each.

All the matter (antimatter) transforms under the fundamental (antifundamental) of the $U(N_c)$ gauge group, due to the stack of N D3-branes.

Matter Content:

$N_f - 1$ flavours of massless matter transforming in the fundamental of $U(N_c)$.

$N_f - 1$ flavours of massless antimatter transforming in the antifundamental of $U(N_c)$.

One flavour of massive matter, with mass m , transforming in the fundamental of $U(N_c)$.

One flavour of massive antimatter, with mass m , transforming in the antifundamental of $U(N_c)$.

Aharony and Giveon-Kutasov Duality:

In the above brane configuration, the number of NS5'-branes in the web is left unspecified as p . This is because the Chern-Simons level is determined by:

$$k = \frac{p}{q} \quad (8.6)$$

where q is the number of D5-branes in the (p, q) -web. Since the brane configuration above corresponds to $q = 1$, in order for k to be left as general and unfixed, any number of NS5'-branes is permitted.

As was explained in section 5.2, integrating out the massive matter field gives rise to the term:

$$\frac{q^2}{2} \frac{1}{4\pi} \frac{m}{|m|} \int d^3x \epsilon^{\mu\nu\rho} \text{Tr} \left(A_\mu(x) \partial_\nu A_\rho(x) + \frac{2}{3} A_\mu(x) A_\nu(x) A_\rho(x) \right) \quad (8.7)$$

in the low energy effective action. $m/|m|$ corresponds to the sign of the mass ($m/|m| = \text{sign}(m)$), which in this case is $+1$. Also, $q = +1$. Subsequently, the above expression corresponds to half of a non-abelian Chern-Simons term, which is just a contribution $k \rightarrow k + \frac{1}{2}$. There is also a massive antimatter field which, when integrated out, contributes:

$$\frac{(-q)^2}{2} \frac{1}{4\pi} \frac{m}{|m|} \int d^3x \epsilon^{\mu\nu\rho} \text{Tr} \left(A_\mu(x) \partial_\nu A_\rho(x) + \frac{2}{3} A_\mu(x) A_\nu(x) A_\rho(x) \right) \quad (8.8)$$

Again $m/|m| = +1$ and $q = +1$, so the contribution is another half Chern-Simons term.

In total $k \rightarrow k + 1$. Integrating out the massive matter means the transition from a high energy $U(N_c)_k$ theory, with $N_f - 1$ massless flavours and one massive flavour, to a low energy $U(N_c)_{k+1}$ theory, with $N_f - 1$ massless flavours.

Consider the high energy theory with $k = 0$. Without the inclusion of massive flavours, this would give rise to a low energy $k = 0$ theory which would exhibit Aharony duality. With the inclusion of one flavour of massive matter, this transitions from a high energy $U(N_c)_0$ theory to a low energy $U(N_c)_1$ theory. The electric $U(N_c)_1$ theory is Giveon-Kutasov dual to a $U((N_f - 1) + 1 - N_c)_{-1} = U(N_f - N_c)_{-1}$ magnetic theory. In this case the theory is said to flow from an Aharony to a Giveon-Kutasov duality. For a high energy theory with $U(N_c)_{-1}$, the low energy theory becomes $U(N_c)_0$ which is Aharony dual to $U(N_f - 1 - N_c)_0$. In this case the flow is from a Giveon-Kutasov duality to an Aharony Duality. For $U(N_c)_k$ with $k \neq 0, -1$ the low energy theory has Chern-Simons level that is neither 1 or 0 and there is no flow between dualities, although the low energy theories do exhibit Giveon-Kutasov duality.

High energy theory is $U(N_c)_k$ with $N_f - 1$ massless flavours of matter and antimatter and one massive flavour of matter and antimatter. Low energy theory is $U(N_c)_{k+1}$ with $N_f - 1$ flavours of massless matter and antimatter.

$k = 0$ results in a flow from Aharony duality to Giveon-Kutasov duality, where the electric theory is $U(N_c)_1$ and the magnetic theory is $U(N_f - N_c)_{-1}$.

$k = -1$ results in a flow from Giveon-Kutasov duality to Aharony duality, where

the electric theory is $U(N_c)_0$ and the magnetic theory is $U(N_f - 1 - N_c)_0$.

$k \neq 0, -1$ results in no flows between dualities. The low energy theory exhibits Giveon-Kutasov duality, where the electric theory is $U(N_c)_{k+1}$ and the magnetic theory is $U(N_f - 1 + |k + 1| - N_c)_{-k-1}$.

8.1.2 One D3-brane Displaced Upwards

Now consider a slightly more complicated case. As well as the single displaced (N_f^{th}) NS5-brane, out of the N_c D3-branes, take the N_c^{th} D3-brane to be displaced in the positive x_3 -direction: The D5-branes labelled by the flavour indices $1, \dots, N_f - 1$ are at $x_3 = 0$, corresponding to $m_1^1, m_2^2, \dots, m_{N_f-1}^{N_f-1} = \tilde{m}_1^1, \tilde{m}_2^2, \dots, \tilde{m}_{N_f-1}^{N_f-1} = 0$. The N_f^{th} D5-brane is displaced and split into a $D5^+$ at $x_3 = m$ and a $D5^-$ at $x_3 = -m$, corresponding to $m_{N_f}^{N_f} = \tilde{m}_{N_f}^{N_f} = m$. The D3-branes labelled by the colour indices $1, \dots, N_c - 1$ are at $x_3 = 0$, corresponding to $\sigma_1^1, \sigma_2^2, \dots, \sigma_{N_c-1}^{N_c-1} = 0$. Lastly, the N_c^{th} D3-brane is at $x_3 = m$, corresponding to $\sigma_{N_c}^{N_c} = -m$. The configuration is given by:

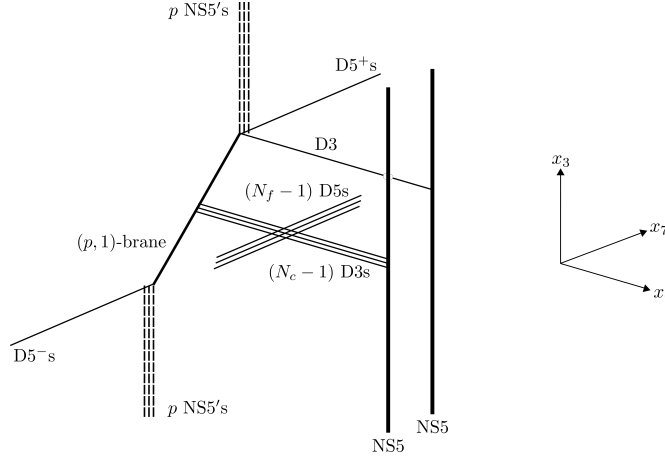

Matter Content:

$N_f - 1$ flavours of massless matter transforming in the fundamental of $U(N_c - 1)$.

$N_f - 1$ flavours of massless antimatter transforming in the antifundamental of $U(N_c - 1)$.

One flavour of massive matter, with mass m , transforming in the fundamental of $U(N_c - 1)$.

One flavour of massive antimatter, with mass m , transforming in the antifundamental of $U(N_c - 1)$.

$N_f - 1$ flavours of massive matter, with mass $-m$, transforming in the fundamental of $U(1)$.

$N_f - 1$ flavours of massive antimatter, with mass m , transforming in the antifundamental of $U(1)$.

One flavour of massless matter transforming in the fundamental of $U(1)$.

One flavour of massive antimatter, with mass $2m$ transforming in the antifundamental of $U(1)$.

Aharony and Giveon-Kutasov Duality:

The high energy theory is:

$$U(N_c - 1)_k \times U(1)_k \tag{8.9}$$

with the matter content as listed in the box above. The low energy theory is:

$$U(N_c - 1)_{k+1} \times U(1)_{k+1/2} \tag{8.10}$$

with only the massless content of the box above.

Dualities:

$k = -1$) The high energy theory is $U(N_c - 1)_{-1} \times U(1)_{-1}$, the low energy theory is $U(N_c - 1)_0 \times U(1)_{-1/2}$. The $U(N_c - 1)$ gauge theory exhibits a flow from Giveon-Kutasov to Aharony Duality. The $U(1)$ gauge theory exhibits no flows between dualities, and is Giveon-Kutasov dual at low energies.

$k = -1/2$) The high energy theory is $U(N_c - 1)_{-1/2} \times U(1)_{-1/2}$, the low energy theory is $U(N_c - 1)_{1/2} \times U(1)_0$. The $U(N_c - 1)$ gauge theory exhibits no flow in dualities, and is Giveon-Kutasov dual at low energies. The $U(1)$ gauge theory exhibits a flow from Giveon-Kutasov to Aharony duality.

$k = 0$) The high energy theory is $U(N_c - 1)_0 \times U(1)_0$. The low energy theory is $U(N_c - 1)_1 \times U(1)_{1/2}$. Both gauge groups exhibit a flow from Aharony to Giveon-Kutasov Duality.

$k \neq -1, -1/2, 0$) In this case there is no flow between dualities, and both gauge groups exhibit Giveon-Kutasov duality at low energies.

8.1.3 One D3-brane Displaced Downwards

In the previous section, one D3-brane was displaced in the positive x_3 -direction. Alternatively, it is possible to displace a single D3-brane in the negative x_3 -direction: The D5-branes labelled by the flavour indices $1, \dots, N_f - 1$ are at $x_3 = 0$, corresponding to $m_1^1, m_2^2, \dots, m_{N_f-1}^{N_f-1} = \tilde{m}_1^1, \tilde{m}_2^2, \dots, \tilde{m}_{N_f-1}^{N_f-1} = 0$. The N_f^{th} D5-brane is displaced and split into a $D5^+$ at $x_3 = m$ and a $D5^-$ at $x_3 = -m$, corresponding to $m_{N_f}^{N_f} = \tilde{m}_{N_f}^{N_f} = m$. The D3-branes labelled by the colour indices $1, \dots, N_c - 1$ are at $x_3 = 0$, corresponding to $\sigma_1^1, \sigma_2^2, \dots, \sigma_{N_c-1}^{N_c-1} = 0$. Lastly, the N_c^{th} D3-brane is at $x_3 = -m$, corresponding to $\sigma_{N_c}^{N_c} = m$. The configuration is given by:

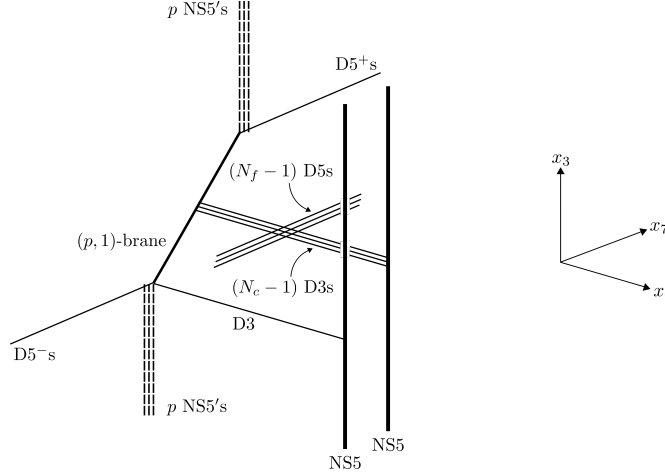

Matter Content:

$N_f - 1$ flavours of massless matter transforming in the fundamental of $U(N_c - 1)$.

$N_f - 1$ flavours of massless antimatter transforming in the antifundamental of $U(N_c - 1)$.

One flavour of massive matter, with mass m , transforming in the fundamental of $U(N_c - 1)$.

One flavour of massive antimatter, with mass m , transforming in the antifundamental of $U(N_c - 1)$.

$N_f - 1$ flavours of massive matter, with mass m , transforming in the fundamental of $U(1)$.

$N_f - 1$ flavours of massive antimatter, with mass $-m$, transforming in the antifundamental of $U(1)$.

One flavour of massive matter, with mass $2m$, transforming in the fundamental of $U(1)$.

One flavour of massless antimatter transforming in the antifundamental of $U(1)$.

Aharony and Giveon-Kutasov Duality:

The high energy theory is:

$$U(N_c - 1)_k \times U(1)_k \tag{8.11}$$

with the matter content as listed in the box above. The low energy theory is:

$$U(N_c - 1)_{k+1} \times U(1)_{k+1/2} \tag{8.12}$$

with only the massless content of the box above.

Dualities:

$k = -1$) The high energy theory is $U(N_c - 1)_{-1} \times U(1)_{-1}$, the low energy theory is $U(N_c - 1)_0 \times U(1)_{-1/2}$. The $U(N_c - 1)$ gauge theory exhibits a flow from Giveon-Kutasov to Aharony Duality. The $U(1)$ gauge theory exhibits no flows between dualities, and is Giveon-Kutasov dual at low energies.

$k = -1/2$) The high energy theory is $U(N_c - 1)_{-1/2} \times U(1)_{-1/2}$, the low energy theory is $U(N_c - 1)_{1/2} \times U(1)_0$. The $U(N_c - 1)$ gauge theory exhibits no flow in dualities, and is Giveon-Kutasov dual at low energies. The $U(1)$ gauge theory exhibits a flow from Giveon-Kutasov to Aharony duality.

$k = 0$) The high energy theory is $U(N_c - 1)_0 \times U(1)_0$. The low energy theory is $U(N_c - 1)_1 \times U(1)_{1/2}$. Both gauge groups exhibit a flow from Aharony to Giveon-Kutasov Duality.

$k \neq -1, -1/2, 0$) In this case there is no flow between dualities, and both gauge groups exhibit Giveon-Kutasov duality at low energies.

8.1.4 Two D3-branes Displaced Upwards

As a further generalisation, consider displacing two D3-branes in the positive x_3 -direction: The D5-branes labelled by the flavour indices $1, \dots, N_f - 1$ are at $x_3 = 0$, corresponding to $m_1^1, m_2^2, \dots, m_{N_f-1}^{N_f-1} = \tilde{m}_1^1, \tilde{m}_2^2, \dots, \tilde{m}_{N_f-1}^{N_f-1} = 0$. The N_f^{th} D5-brane is displaced and split into a $D5^+$ at $x_3 = m$ and a $D5^-$ at $x_3 = -m$, corresponding to $m_{N_f}^{N_f} = \tilde{m}_{N_f}^{N_f} = m$. The D3-branes labelled by the colour indices $1, \dots, N_c - 2$ are at $x_3 = 0$, corresponding to $\sigma_1^1, \sigma_2^2, \dots, \sigma_{N_c-2}^{N_c-2} = 0$. Lastly, the $(N_c - 1)^{\text{th}}$ and N_c^{th} D3-branes are at $x_3 = m$, corresponding to $\sigma_{N_c-1}^{N_c-1} = \sigma_{N_c}^{N_c} = -m$. The configuration is given by:

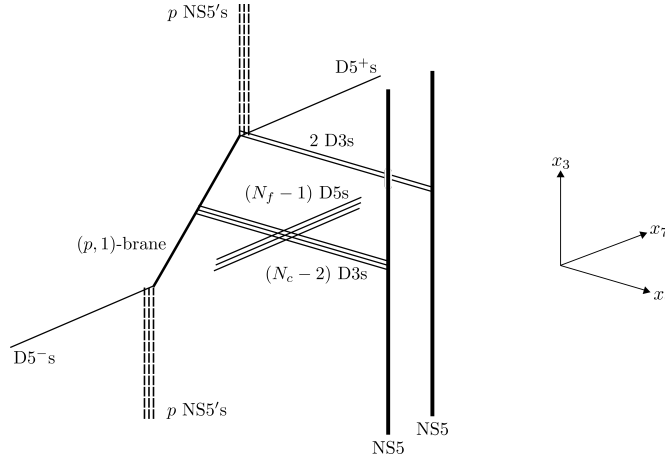

Matter Content:

$N_f - 1$ flavours of massless matter transforming in the fundamental of $U(N_c - 2)$.

$N_f - 1$ flavours of massless antimatter transforming in the antifundamental of $U(N_c - 2)$.

One flavour of massive matter, with mass m , transforming in the fundamental of $U(N_c - 2)$.

One flavour of massive antimatter, with mass m , transforming in the antifundamental of $U(N_c - 2)$.

$N_f - 1$ flavours of massive matter, with mass $-m$, transforming in the fundamental of $U(2)$.

$N_f - 1$ flavours of massive antimatter, with mass m , transforming in the antifundamental of $U(2)$.

One flavour of massless matter transforming in the fundamental of $U(2)$.

One flavour of massive antimatter, with mass $2m$ transforming in the antifundamental of $U(2)$.

Aharony and Giveon-Kutasov Duality:

The high energy theory is:

$$U(N_c - 2)_k \times U(2)_k \quad (8.13)$$

with the matter content as listed in the box above. The low energy theory is:

$$U(N_c - 2)_{k+1} \times U(2)_{k+1/2} \quad (8.14)$$

with only the massless content of the box above.

Dualities:

$k = -1$) The high energy theory is $U(N_c - 2)_{-1} \times U(2)_{-1}$, the low energy theory is $U(N_c - 2)_0 \times U(2)_{-1/2}$. The $U(N_c - 2)$ gauge theory exhibits a flow from Giveon-Kutasov to Aharony Duality. The $U(2)$ gauge theory exhibits no flows between dualities, and is Giveon-Kutasov dual at low energies.

$k = -1/2$) The high energy theory is $U(N_c - 2)_{-1/2} \times U(2)_{-1/2}$, the low energy theory is $U(N_c - 2)_{1/2} \times U(2)_0$. The $U(N_c - 2)$ gauge theory exhibits no flow in dualities, and is Giveon-Kutasov dual at low energies. The $U(2)$ gauge theory exhibits a flow from Giveon-Kutasov to Aharony duality.

$k = 0$) The high energy theory is $U(N_c - 2)_0 \times U(2)_0$. The low energy theory is $U(N_c - 2)_1 \times U(2)_{1/2}$. Both gauge groups exhibit a flow from Aharony to Giveon-Kutasov Duality.

$k \neq -1, -1/2, 0$) In this case there is no flow between dualities, and both gauge groups exhibit Giveon-Kutasov duality at low energies.

8.1.5 Two D3-branes Displaced Downwards

Consider displacing two D3-branes in the negative x_3 -direction: The D5-branes labelled by the flavour indices $1, \dots, N_f - 1$ are at $x_3 = 0$, corresponding to $m_1^1, m_2^2, \dots, m_{N_f-1}^{N_f-1} = \tilde{m}_1^1, \tilde{m}_2^2, \dots, \tilde{m}_{N_f-1}^{N_f-1} = 0$. The N_f^{th} D5-brane is displaced and split into a $D5^+$ at $x_3 = m$ and a $D5^-$ at $x_3 = -m$, corresponding to $m_{N_f}^{N_f} = \tilde{m}_{N_f}^{N_f} = m$. The D3-branes labelled by the colour indices $1, \dots, N_c - 2$ are at $x_3 = 0$, corresponding to $\sigma_1^1, \sigma_2^2, \dots, \sigma_{N_c-2}^{N_c-2} = 0$. Lastly, the $(N_c - 1)^{\text{th}}$ and N_c^{th} D3-branes are at $x_3 = -m$, corresponding to $\sigma_{N_c-1}^{N_c-1} = \sigma_{N_c}^{N_c} = m$. The configuration is given by:

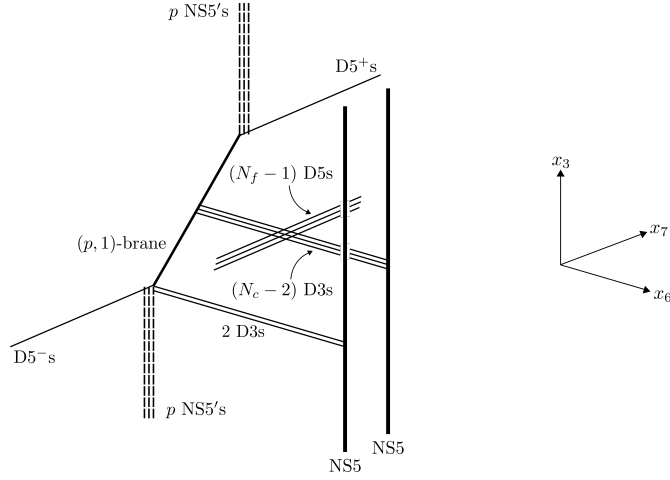

Matter Content:

$N_f - 1$ flavours of massless matter transforming in the fundamental of $U(N_c - 2)$.

$N_f - 1$ flavours of massless antimatter transforming in the antifundamental of $U(N_c - 2)$.

One flavour of massive matter, with mass m , transforming in the fundamental of $U(N_c - 2)$.

One flavour of massive antimatter, with mass m , transforming in the antifundamental of $U(N_c - 2)$.

$N_f - 1$ flavours of massive matter, with mass m , transforming in the fundamental of $U(2)$.

$N_f - 1$ flavours of massive antimatter, with mass $-m$, transforming in the antifundamental of $U(2)$.

One flavour of massive matter, with mass $2m$, transforming in the fundamental of $U(2)$.

One flavour of massless antimatter transforming in the antifundamental of $U(2)$.

Aharony and Giveon-Kutasov Duality:

The high energy theory is:

$$U(N_c - 2)_k \times U(2)_k \tag{8.15}$$

with the matter content as listed in the box above. The low energy theory is:

$$U(N_c - 2)_{k+1} \times U(2)_{k+1/2} \tag{8.16}$$

with only the massless content of the box above.

Dualities:

$k = -1$) The high energy theory is $U(N_c - 2)_{-1} \times U(2)_{-1}$, the low energy theory is $U(N_c - 2)_0 \times U(2)_{-1/2}$. The $U(N_c - 2)$ gauge theory exhibits a flow from Giveon-Kutasov to Aharony Duality. The $U(2)$ gauge theory exhibits no flows between dualities, and is Giveon-Kutasov dual at low energies.

$k = -1/2$) The high energy theory is $U(N_c - 2)_{-1/2} \times U(2)_{-1/2}$, the low energy theory is $U(N_c - 2)_{1/2} \times U(2)_0$. The $U(N_c - 2)$ gauge theory exhibits no flow in dualities, and is Giveon-Kutasov dual at low energies. The $U(2)$ gauge theory exhibits a flow from Giveon-Kutasov to Aharony duality.

$k = 0$) The high energy theory is $U(N_c - 2)_0 \times U(2)_0$. The low energy theory is $U(N_c - 2)_1 \times U(2)_{1/2}$. Both gauge groups exhibit a flow from Aharony to Giveon-Kutasov Duality.

$k \neq -1, -1/2, 0$) In this case there is no flow between dualities, and both gauge groups exhibit Giveon-Kutasov duality at low energies.

8.1.6 One D3-brane Displaced Upwards and One D3-brane Displaced Downwards

Consider displacing one D3-brane in the positive x_3 -direction and one D3-brane in the negative x_3 -direction: The D5-branes labelled by the flavour indices $1, \dots, N_f - 1$ are at $x_3 = 0$, corresponding to $m_1^1, m_2^2, \dots, m_{N_f-1}^{N_f-1} = \tilde{m}_1^1, \tilde{m}_2^2, \dots, \tilde{m}_{N_f-1}^{N_f-1} = 0$. The N_f^{th} D5-brane is displaced and split into a $D5^+$ at $x_3 = m$ and a $D5^-$ at $x_3 = -m$, corresponding to $m_{N_f}^{N_f} = \tilde{m}_{N_f}^{N_f} = m$. The D3-branes labelled by the colour indices $1, \dots, N_c - 2$ are at $x_3 = 0$, corresponding to $\sigma_1^1, \sigma_2^2, \dots, \sigma_{N_c-2}^{N_c-2} = 0$. Lastly, the $(N_c - 1)^{\text{th}}$ D3-brane is at $x_3 = -m$ corresponding to $\sigma_{N_c-1}^{N_c-1} = m$ and the N_c^{th} D3-brane is at $x_3 = m$ corresponding to $\sigma_{N_c}^{N_c} = -m$. The configuration is given by:

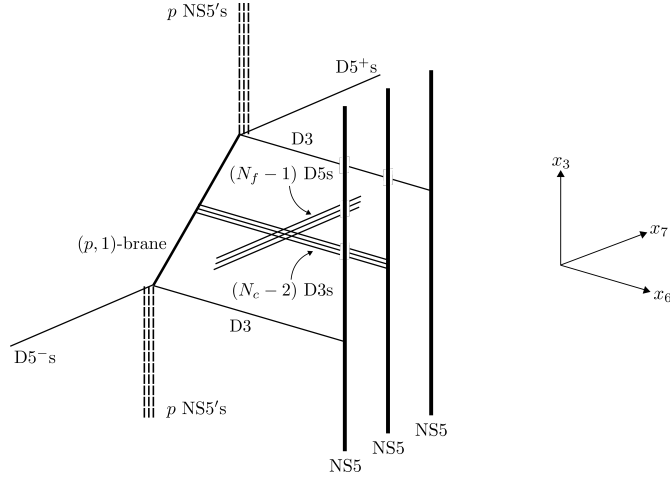

Matter Content:

$N_f - 1$ flavours of massless matter transforming in the fundamental of $U(N_c - 2)$.

$N_f - 1$ flavours of massless antimatter transforming in the antifundamental of $U(N_c - 2)$.

One flavour of massive matter, with mass m , transforming in the fundamental of $U(N_c - 2)$.

One flavour of massive antimatter, with mass m , transforming in the antifundamental of $U(N_c - 2)$.

$N_f - 1$ flavours of massive matter, with mass m , transforming in the fundamental of $U(1)$.

$N_f - 1$ flavours of massive antimatter, with mass $-m$, transforming in the antifundamental of $U(1)$.

One flavour of massive matter, with mass $2m$, transforming in the fundamental of $U(1)$.

One flavour of massless antimatter transforming in the antifundamental of $U(1)$.

$N_f - 1$ flavours of massive matter, with mass $-m$, transforming in the fundamental of $U(1)$.

$N_f - 1$ flavours of massive antimatter, with mass m , transforming in the antifundamental of $U(1)$.

One flavour of massless matter transforming in the fundamental of $U(1)$.

One flavour of massive antimatter, with mass $2m$ transforming in the antifundamental of $U(1)$.

Aharony and Giveon-Kutasov Duality:

The high energy theory is:

$$U(N_c - 2)_k \times U(1)_k \times U(1)_k \tag{8.17}$$

with the matter content as listed in the box above. The low energy theory is:

$$U(N_c - 2)_{k+1} \times U(1)_{k+1/2} \times U(1)_{k+1/2} \tag{8.18}$$

with only the massless content of the box above.

Dualities:

$k = -1$) The high energy theory is $U(N_c - 2)_{-1} \times U(1)_{-1} \times U(1)_{-1}$, the low energy theory is $U(N_c - 2)_0 \times U(1)_{-1/2} \times U(1)_{-1/2}$. The $U(N_c - 2)$ gauge theory exhibits a flow from Giveon-Kutasov to Aharony Duality. The $U(1)$ gauge theories exhibit no flows between dualities, and is Giveon-Kutasov dual at low energies.

$k = -1/2$) The high energy theory is $U(N_c - 2)_{-1/2} \times U(1)_{-1/2} \times U(1)_{-1/2}$, the low energy theory is $U(N_c - 2)_{1/2} \times U(1)_0 \times U(1)_0$. The $U(N_c - 2)$ gauge theory exhibits no flow in dualities, and is Giveon-Kutasov dual at low energies. The $U(1)$ gauge theories exhibit a flow from Giveon-Kutasov to Aharony duality.

$k = 0$) The high energy theory is $U(N_c - 2)_0 \times U(1)_0 \times U(1)_0$. The low energy theory is $U(N_c - 2)_1 \times U(1)_{1/2} \times U(1)_{1/2}$. All gauge groups exhibit a flow from Aharony to Giveon-Kutasov Duality.

$k \neq -1, -1/2, 0$) In this case there is no flow between dualities, and both gauge groups exhibit Giveon-Kutasov duality at low energies.

8.2 Two Displaced Flavour Branes

Consider a further generalisation, where, of the N_f D5-branes, the $(N_f - 1)^{\text{th}}$ and the N_f^{th} both split to form a web consisting of a $(p, 2)$ -brane with p NS5'-branes and two D5⁺-branes on one end, and p NS5'-branes and two D5⁻-branes on the other end. The D5⁺ branes are placed at $x_3 = m$ whilst the D5⁻ branes are placed at $x_3 = -m$. As in the previous section, it is possible to look at a number of cases, corresponding to different numbers of D3-branes displaced along the x_3 in either the positive or negative direction.

8.2.1 No Displaced D3-branes

For the case of two displaced D5-branes, the simplest possibility for the D3-branes is to have none displaced in the x_3 -direction. This case will be explained in detail, then, for brevity, future sections will only display the results: The D5-branes labelled by the flavour indices $1, \dots, N_f - 2$ are at $x_3 = 0$, corresponding to $m_1^1, m_2^2, \dots, m_{N_f-2}^{N_f-2} = \tilde{m}_1^1, \tilde{m}_2^2, \dots, \tilde{m}_{N_f-2}^{N_f-2} = 0$. The $(N_f - 1)^{\text{th}}$ and N_f^{th} D5-branes are displaced and split into two D5⁺s at $x_3 = m$ and two D5⁻s at $x_3 = -m$, corresponding to $m_{N_f-1}^{N_f-1} = m_{N_f}^{N_f} = \tilde{m}_{N_f-1}^{N_f-1} = \tilde{m}_{N_f}^{N_f} = m$. The D3-branes labelled by the colour indices $1, \dots, N_c$ are at $x_3 = 0$, corresponding to $\sigma_1^1, \sigma_2^2, \dots, \sigma_{N_c}^{N_c} = 0$. The configuration is given by:

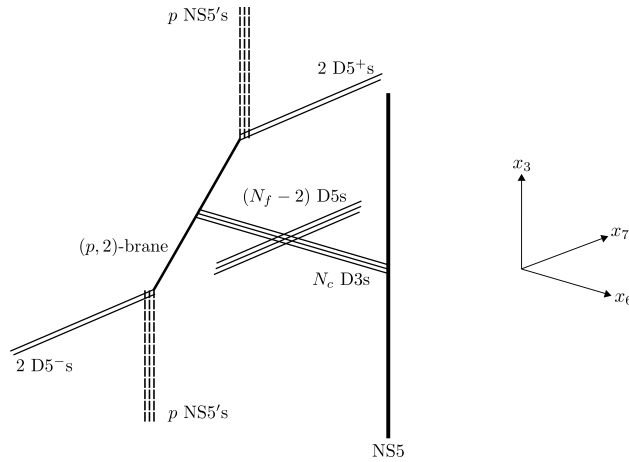

Recall that the following equations (4.51 and 4.52) need to be satisfied:

$$\left(\delta_j^{j'} m_i^{i'} + \sigma_j^{j'} \delta_i^{i'} \right) \phi^{i,j} = 0 \quad (8.19)$$

$$\left(\delta_j^{j'} \tilde{m}_i^{i'} - \sigma_j^{j'} \delta_i^{i'} \right) \tilde{\phi}^{i,j} = 0 \quad (8.20)$$

Note that, since the scalars of the chiral multiplet are set to zero ($\phi^{i,j} = \tilde{\phi}^{i,j} = 0$), $\sigma_j^{j'}$, $m_i^{i'}$ and $\tilde{m}_i^{i'}$ can take any value. As a result the positions of the D3-branes and D5-branes are unrestricted. In this case all $\sigma_j^{j'}$ equal zero.

The mass terms of the chiral (matter) multiplets are given by:

$$\begin{aligned}
V_{sc} \ni & \sum_{i=1}^{N_f} \bar{\phi}_{i'',j''} \left(\delta_{j'}^{j''} m_{i'}^{i''} + \sigma_{j'}^{j''} \delta_{i'}^{i''} \right) \left(\delta_j^{j'} m_i^{i'} + \sigma_j^{j'} \delta_i^{i'} \right) \phi^{i,j} \\
& + \sum_{i=1}^{N_f} \tilde{\phi}_{i'',j''} \left(\delta_{j'}^{j''} \tilde{m}_{i'}^{i''} - \sigma_{j'}^{j''} \delta_{i'}^{i''} \right) \left(\delta_j^{j'} \tilde{m}_i^{i'} - \sigma_j^{j'} \delta_i^{i'} \right) \tilde{\phi}^{i,j}
\end{aligned} \tag{8.21}$$

Consider, first, the $N_f - 2$ D5-branes. It is expected that the zero length strings between them and the D3-brane stack will give rise to $N_f - 2$ flavours of massless matter. This is evident from the mass terms

$$\begin{aligned}
V_{sc} \ni & \bar{\phi}_{1,j''} \left(\delta_{j'}^{j''}(0) + (0)\delta_{j'}^{j''} \right) \left(\delta_j^{j'}(0) + (0)\delta_j^{j'} \right) \phi^{1,j} \\
& + \bar{\phi}_{2,j''} \left(\delta_{j'}^{j''}(0) + (0)\delta_{j'}^{j''} \right) \left(\delta_j^{j'}(0) + (0)\delta_j^{j'} \right) \phi^{2,j} \\
& + \dots + \bar{\phi}_{N_f-2,j''} \left(\delta_{j'}^{j''}(0) + (0)\delta_{j'}^{j''} \right) \left(\delta_j^{j'}(0) + (0)\delta_j^{j'} \right) \phi^{N_f-2,j}
\end{aligned} \tag{8.22}$$

All the N_c values of the diagonal matrix $\sigma_j^{j'}$ are zero since all the D3-branes are placed at $x_3 = 0$. On the other hand only those diagonal entries of $m_i^{i'}$ corresponding to $i, i' = 1, \dots, N_f - 2$ take the value zero, due to $N_f - 2$ of the D5-branes being placed at $x_3 = 0$. This corresponds to $N_f - 2$ massless flavours of matter. Similarly:

$$\begin{aligned}
V_{sc} \ni & \tilde{\phi}_{1,j''} \left(\delta_{j'}^{j''}(0) - (0)\delta_{j'}^{j''} \right) \left(\delta_j^{j'}(0) - (0)\delta_j^{j'} \right) \tilde{\phi}^{1,j} \\
& + \tilde{\phi}_{2,j''} \left(\delta_{j'}^{j''}(0) - (0)\delta_{j'}^{j''} \right) \left(\delta_j^{j'}(0) - (0)\delta_j^{j'} \right) \tilde{\phi}^{2,j} \\
& + \dots + \tilde{\phi}_{N_f-2,j''} \left(\delta_{j'}^{j''}(0) - (0)\delta_{j'}^{j''} \right) \left(\delta_j^{j'}(0) - (0)\delta_j^{j'} \right) \tilde{\phi}^{N_f-2,j}
\end{aligned} \tag{8.23}$$

This gives rise to $N_f - 2$ massless flavours of antimatter.

The two D5⁺-branes and two D5⁻-branes are expected to contribute two flavours of massive matter and antimatter to the theory. The matter has mass terms:

$$\begin{aligned}
V_{sc} \ni & \bar{\phi}_{N_f-1,j''} \left(\delta_{j'}^{j''} m + (0)\delta_{j'}^{j''} \right) \left(\delta_j^{j'} m + (0)\delta_j^{j'} \right) \phi^{N_f-1,j} \\
& + \bar{\phi}_{N_f,j''} \left(\delta_{j'}^{j''} m + (0)\delta_{j'}^{j''} \right) \left(\delta_j^{j'} m + (0)\delta_j^{j'} \right) \phi^{N_f,j}
\end{aligned} \tag{8.24}$$

where $m_{N_f-1}^{N_f-1} = m_{N_f}^{N_f} = m$ due to the two D5⁺-branes displaced upwards in the x_3 -direction. This corresponds to two flavours of matter with mass m . Similarly:

$$V_{sc} \ni \bar{\phi}_{N_f-1,j''} \left(\delta_{j'}^{j''} m - (0) \delta_{j'}^{j''} \right) \left(\delta_j^{j'} m - (0) \delta_j^{j'} \right) \tilde{\phi}^{N_f-1,j} \\ + \bar{\phi}_{N_f,j''} \left(\delta_{j'}^{j''} m - (0) \delta_{j'}^{j''} \right) \left(\delta_j^{j'} m - (0) \delta_j^{j'} \right) \tilde{\phi}^{N_f,j} \quad (8.25)$$

where $\tilde{m}_{N_f-1}^{N_f-1} = \tilde{m}_{N_f}^{N_f} = m$ due to the two D5⁻-branes displaced downwards in the x_3 -direction. This corresponds to two flavours of antimatter with mass m .

All the matter (antimatter) transforms under the fundamental (antifundamental) of the $U(N_c)$ gauge group, due to the stack of N_c D3-branes.

Matter Content:

$N_f - 2$ flavours of massless matter transforming in the fundamental of $U(N_c)$.

$N_f - 2$ flavours of massless antimatter transforming in the antifundamental of $U(N_c)$.

Two flavours of massive matter, with mass m , transforming in the fundamental of $U(N_c)$.

Two flavours of massive antimatter, with mass m , transforming in the antifundamental of $U(N_c)$.

Aharony and Giveon-Kutasov Duality:

A $U(N_c)_k$ theory with N_f massless flavours of matter corresponds to an NS5'-brane in place of the web of branes, and all N_f D5-branes at $x_3 = 0$. Mass is introduced to two flavours by changing to the brane configuration above. Integrating out the two massive matter fields gives rise to:

$$2 \times \frac{q^2}{2} \frac{1}{4\pi} \frac{m}{|m|} \int d^3x \epsilon^{\mu\nu\rho} \text{Tr} \left(A_\mu(x) \partial_\nu A_\rho(x) + \frac{2}{3} A_\mu(x) A_\nu(x) A_\rho(x) \right) \quad (8.26)$$

$m/|m|$ corresponds to the sign of the mass ($m/|m| = \text{sign}(m)$), which in this case is $+1$. Also, $q = +1$. Therefore the above corresponds to two times a half of a non-abelian Chern-Simons term, which is just a contribution of an extra Chern-Simons term $k \rightarrow k + 1$. There are also two massive antimatter fields which, when integrated out, contribute:

$$2 \times \frac{(-q)^2}{2} \frac{1}{4\pi} \frac{m}{|m|} \int d^3x \epsilon^{\mu\nu\rho} \text{Tr} \left(A_\mu(x) \partial_\nu A_\rho(x) + \frac{2}{3} A_\mu(x) A_\nu(x) A_\rho(x) \right) \quad (8.27)$$

Again $m/|m| = +1$ and $q = +1$, so the contribution is another Chern-Simons term.

In total $k \rightarrow k + 2$. Integrating out the massive matter means the transition from a high energy $U(N_c)_k$ theory, with $N_f - 2$ massless flavours and 2 massive flavours, to a low energy $U(N_c)_{k+2}$ theory, with $N_f - 2$ massless flavours.

Consider the high energy theory with $k = 0$. Without the inclusion of massive flavours, this would give rise to a low energy $k = 0$ theory which would exhibit Aharony duality. With the inclusion of two flavours of massive matter this transition is from a high energy $U(N_c)_0$ theory to a low energy $U(N_c)_2$ theory. The electric $U(N_c)_2$ theory is Giveon-Kutasov dual to a $U((N_f - 2) + 2 - N_c)_{-2} = U(N_f - N_c)_{-2}$ magnetic theory. In this case the theory is said to flow from an Aharony to a Giveon-Kutasov duality. For a high energy theory with $U(N_c)_{-2}$ the high energy theory becomes $U(N_c)_0$ which is Aharony dual to $U(N_f - 2 - N_c)_0$. In this case the flow is from a Giveon-Kutasov duality to an Aharony Duality. For $U(N_c)_k$ with $k \neq 0, -2$ the low energy theory has Chern-Simons level that is neither 2 nor 0 and there is no flow between dualities, although the low energy theories do exhibit Giveon-Kutasov duality.

High energy theory is $U(N_c)_k$ with $N_f - 2$ massless flavours of matter and antimatter and 2 massive flavours of matter and antimatter. Low energy theory is $U(N_c)_{k+2}$ with $N_f - 2$ flavours of massless matter and antimatter.

$k = 0$ results in a flow from Aharony duality to Giveon-Kutasov duality, where the electric theory is $U(N_c)_2$ and the magnetic theory is $U(N_f - N_c)_{-2}$.

$k = -2$ results in a flow from Giveon-Kutasov duality to Aharony duality, where the electric theory is $U(N_c)_0$ and the magnetic theory is $U(N_f - 2 - N_c)_0$.

$k \neq 0, -2$ results in no flows between dualities. The low energy theory exhibits Giveon-Kutasov duality, where the electric theory is $U(N_c)_{k+2}$ and the magnetic theory is $U(N_f - 2 + |k + 2| - N_c)_{k+2}$.

8.2.2 One D3-brane Displaced Upwards

As well as the displaced $(N_f - 1)^{\text{th}}$ and N_f^{th} NS5-branes, out of the N_c D3-branes, take the N_c^{th} D3-brane to be displaced in the positive x_3 -direction: The D5-branes labelled by the flavour indices $1, \dots, N_f - 2$ are at $x_3 = 0$, corresponding to

$m_1^1, m_2^2, \dots, m_{N_f-2}^{N_f-2} = \tilde{m}_1^1, \tilde{m}_2^2, \dots, \tilde{m}_{N_f-2}^{N_f-2} = 0$. The $(N_f - 1)^{\text{th}}$ and N_f^{th} D5-branes are displaced and split into two D5⁺s at $x_3 = m$ and two D5⁻s at $x_3 = -m$, corresponding to $m_{N_f-1}^{N_f-1} = m_{N_f}^{N_f} = \tilde{m}_{N_f-1}^{N_f-1} = \tilde{m}_{N_f}^{N_f} = m$. The D3-branes labelled by the colour indices $1, \dots, N_c - 1$ are at $x_3 = 0$, corresponding to $\sigma_1^1, \sigma_2^2, \dots, \sigma_{N_c-1}^{N_c-1} = 0$. Lastly, the N_c^{th} D3-brane is at $x_3 = m$, corresponding to $\sigma_{N_c}^{N_c} = -m$. The configuration is given by:

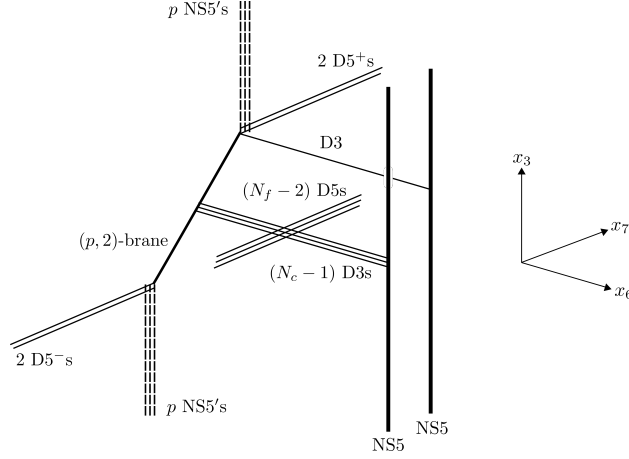

Matter Content:

$N_f - 2$ flavours of massless matter transforming in the fundamental of $U(N_c - 1)$.

$N_f - 2$ flavours of massless antimatter transforming in the antifundamental of $U(N_c - 1)$.

Two flavours of massive matter, with mass m , transforming in the fundamental of $U(N_c - 1)$.

Two flavours of massive antimatter, with mass m , transforming in the antifundamental of $U(N_c - 1)$.

$N_f - 2$ flavours of massive matter, with mass $-m$, transforming in the fundamental of $U(1)$.

$N_f - 2$ flavours of massive antimatter, with mass m , transforming in the antifundamental of $U(1)$.

Two flavours of massless matter transforming in the fundamental of $U(1)$.

Two flavours of massive antimatter, with mass $2m$ transforming in the antifundamental of $U(1)$.

Aharony and Giveon-Kutasov Duality:

The high energy theory is:

$$U(N_c - 1)_k \times U(1)_k \quad (8.28)$$

with the matter content as listed in the box above. The low energy theory is:

$$U(N_c - 1)_{k+2} \times U(1)_{k+1} \quad (8.29)$$

with only the massless content of the box above.

Dualities:

$k = -2$) The high energy theory is $U(N_c - 1)_{-2} \times U(1)_{-2}$, the low energy theory is $U(N_c - 1)_0 \times U(1)_{-1}$. The $U(N_c - 1)$ gauge theory exhibits a flow from Giveon-Kutasov to Aharony Duality. The $U(1)$ gauge theory exhibits no flows between dualities, and is Giveon-Kutasov dual at low energies.

$k = -1$) The high energy theory is $U(N_c - 1)_{-1} \times U(1)_{-1}$, the low energy theory is $U(N_c - 1)_1 \times U(1)_0$. The $U(N_c - 1)$ gauge theory exhibits no flow in dualities, and is Giveon-Kutasov dual at low energies. The $U(1)$ gauge theory exhibits a flow from Giveon-Kutasov to Aharony duality.

$k = 0$) The high energy theory is $U(N_c - 1)_0 \times U(1)_0$. The low energy theory is $U(N_c - 1)_2 \times U(1)_1$. Both gauge groups exhibit a flow from Aharony to Giveon-Kutasov Duality.

$k \neq -2, -1, 0$) In this case there is no flow between dualities, and both gauge groups exhibit Giveon-Kutasov duality at low energies.

8.2.3 One D3-brane Displaced Downwards

Take the N_c^{th} D3-brane to be displaced in the negative x_3 -direction: The D5-branes labelled by the flavour indices $1, \dots, N_f - 2$ are at $x_3 = 0$, corresponding to $m_1^1, m_2^2, \dots, m_{N_f-2}^{N_f-2} = \tilde{m}_1^1, \tilde{m}_2^2, \dots, \tilde{m}_{N_f-2}^{N_f-2} = 0$. The $(N_f - 1)^{\text{th}}$ and N_f^{th} D5-branes are displaced and split into two D5⁺s at $x_3 = m$ and two D5⁻s at $x_3 = -m$, corresponding to $m_{N_f-1}^{N_f-1} = m_{N_f}^{N_f} = \tilde{m}_{N_f-1}^{N_f-1} = \tilde{m}_{N_f}^{N_f} = m$. The D3-branes labelled by the colour indices $1, \dots, N_c - 1$ are at $x_3 = 0$, corresponding to $\sigma_1^1, \sigma_2^2, \dots, \sigma_{N_c-1}^{N_c-1} = 0$. Lastly, the N_c^{th} D3-brane is at $x_3 = -m$, corresponding to $\sigma_{N_c}^{N_c} = m$. The configuration is given by:

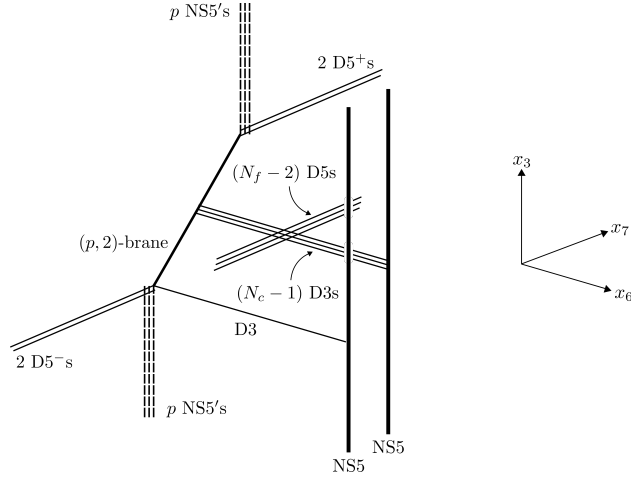

Matter Content:

$N_f - 2$ flavours of massless matter transforming in the fundamental of $U(N_c - 1)$.

$N_f - 2$ flavours of massless antimatter transforming in the antifundamental of $U(N_c - 1)$.

Two flavours of massive matter, with mass m , transforming in the fundamental of $U(N_c - 1)$.

Two flavours of massive antimatter, with mass m , transforming in the antifundamental of $U(N_c - 1)$.

$N_f - 2$ flavours of massive matter, with mass m , transforming in the fundamental of $U(1)$.

$N_f - 2$ flavours of massive antimatter, with mass $-m$, transforming in the antifundamental of $U(1)$.

Two flavours of massive matter, with mass $2m$, transforming in the fundamental of $U(1)$.

Two flavours of massless antimatter transforming in the antifundamental of $U(1)$.

Aharony and Giveon-Kutasov Duality:

The high energy theory is:

$$U(N_c - 1)_k \times U(1)_k \tag{8.30}$$

with the matter content as listed in the box above. The low energy theory is:

$$U(N_c - 1)_{k+2} \times U(1)_{k+1} \tag{8.31}$$

with only the massless content of the box above.

Dualities:

$k = -2$) The high energy theory is $U(N_c - 1)_{-2} \times U(1)_{-2}$, the low energy theory is $U(N_c - 1)_0 \times U(1)_{-1}$. The $U(N_c - 1)$ gauge theory exhibits a flow from Giveon-Kutasov to Aharony Duality. The $U(1)$ gauge theory exhibits no flows between dualities, and is Giveon-Kutasov dual at low energies.

$k = -1$) The high energy theory is $U(N_c - 1)_{-1} \times U(1)_{-1}$, the low energy theory is $U(N_c - 1)_1 \times U(1)_0$. The $U(N_c - 1)$ gauge theory exhibits no flow in dualities, and is Giveon-Kutasov dual at low energies. The $U(1)$ gauge theory exhibits a flow from Giveon-Kutasov to Aharony duality.

$k = 0$) The high energy theory is $U(N_c - 1)_0 \times U(1)_0$. The low energy theory is $U(N_c - 1)_2 \times U(1)_1$. Both gauge groups exhibit a flow from Aharony to Giveon-Kutasov Duality.

$k \neq -2, -1, 0$) In this case there is no flow between dualities, and both gauge groups exhibit Giveon-Kutasov duality at low energies.

8.2.4 Two D3-branes Displaced Upwards

Take the $(N_c - 1)^{\text{th}}$ and N_c^{th} D3-branes to be displaced in the positive x_3 -direction: The D5-branes labelled by the flavour indices $1, \dots, N_f - 2$ are at $x_3 = 0$, corresponding to $m_1^1, m_2^2, \dots, m_{N_f-2}^{N_f-2} = \tilde{m}_1^1, \tilde{m}_2^2, \dots, \tilde{m}_{N_f-2}^{N_f-2} = 0$. The $(N_f - 1)^{\text{th}}$ and N_f^{th} D5-branes are displaced and split into two $D5^+$ s at $x_3 = m$ and two $D5^-$ s at $x_3 = -m$, corresponding to $m_{N_f-1}^{N_f-1} = m_{N_f}^{N_f} = \tilde{m}_{N_f-1}^{N_f-1} = \tilde{m}_{N_f}^{N_f} = m$. The D3-branes labelled by the colour indices $1, \dots, N_c - 2$ are at $x_3 = 0$, corresponding to $\sigma_1^1, \sigma_2^2, \dots, \sigma_{N_c-2}^{N_c-2} = 0$. Lastly, the $(N_c - 1)^{\text{th}}$ and N_c^{th} D3-branes are at $x_3 = m$, corresponding to $\sigma_{N_c-1}^{N_c-1} = \sigma_{N_c}^{N_c} = -m$. The configuration is given by:

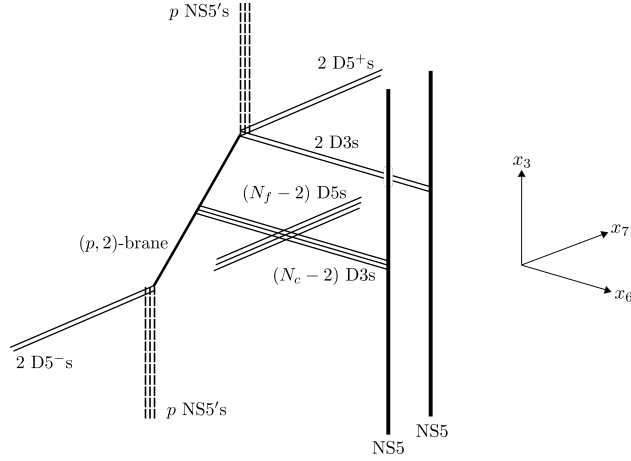

$N_f - 2$ flavours of massless matter transforming in the fundamental of $U(N_c - 2)$.

$N_f - 2$ flavours of massless antimatter transforming in the antifundamental of $U(N_c - 2)$.

Two flavours of massive matter, with mass m , transforming in the fundamental of $U(N_c - 2)$.

Two flavours of massive antimatter, with mass m , transforming in the antifundamental of $U(N_c - 2)$.

$N_f - 2$ flavours of massive matter, with mass $-m$, transforming in the fundamental of $U(2)$.

$N_f - 2$ flavours of massive antimatter, with mass m , transforming in the antifundamental of $U(2)$.

Two flavours of massless matter transforming in the fundamental of $U(2)$.

Two flavours of massive antimatter, with mass $2m$ transforming in the antifundamental of $U(2)$.

Aharony and Giveon-Kutasov Duality:

The high energy theory is:

$$U(N_c - 2)_k \times U(2)_k \tag{8.32}$$

with the matter content as listed in the box above. The low energy theory is:

$$U(N_c - 2)_{k+2} \times U(2)_{k+1} \tag{8.33}$$

with only the massless content of the box above.

Dualities:

$k = -2$) The high energy theory is $U(N_c - 2)_{-2} \times U(2)_{-2}$, the low energy theory is $U(N_c - 2)_0 \times U(2)_{-1}$. The $U(N_c - 2)$ gauge theory exhibits a flow from Giveon-Kutasov to Aharony Duality. The $U(2)$ gauge theory exhibits no flows between dualities, and is Giveon-Kutasov dual at low energies.

$k = -1$) The high energy theory is $U(N_c - 2)_{-1} \times U(2)_{-1}$, the low energy theory is $U(N_c - 2)_1 \times U(2)_0$. The $U(N_c - 2)$ gauge theory exhibits no flow in dualities, and is Giveon-Kutasov dual at low energies. The $U(2)$ gauge theory exhibits a flow from Giveon-Kutasov to Aharony duality.

$k = 0$) The high energy theory is $U(N_c - 2)_0 \times U(2)_0$. The low energy theory is $U(N_c - 2)_2 \times U(2)_1$. Both gauge groups exhibit a flow from Aharony to Giveon-Kutasov Duality.

$k \neq -2, -1, 0$) In this case there is no flow between dualities, and both gauge groups exhibit Giveon-Kutasov duality at low energies.

8.2.5 Two D3-branes Displaced Downwards

Take the $(N_c - 1)^{\text{th}}$ and N_c^{th} D3-branes to be displaced in the negative x_3 -direction: The D5-branes labelled by the flavour indices $1, \dots, N_f - 2$ are at $x_3 = 0$, corresponding to $m_1^1, m_2^2, \dots, m_{N_f-2}^{N_f-2} = \tilde{m}_1^1, \tilde{m}_2^2, \dots, \tilde{m}_{N_f-2}^{N_f-2} = 0$. The $(N_f - 1)^{\text{th}}$ and N_f^{th} D5-branes are displaced and split into two D5⁺s at $x_3 = m$ and two D5⁻s at $x_3 = -m$, corresponding to $m_{N_f-1}^{N_f-1} = m_{N_f}^{N_f} = \tilde{m}_{N_f-1}^{N_f-1} = \tilde{m}_{N_f}^{N_f} = m$. The D3-branes labelled by the colour indices $1, \dots, N_c - 2$ are at $x_3 = 0$, corresponding to $\sigma_1^1, \sigma_2^2, \dots, \sigma_{N_c-2}^{N_c-2} = 0$. Lastly, the $(N_c - 1)^{\text{th}}$ and N_c^{th} D3-branes are at $x_3 = -m$, corresponding to $\sigma_{N_c-1}^{N_c-1} = \sigma_{N_c}^{N_c} = m$. The configuration is given by:

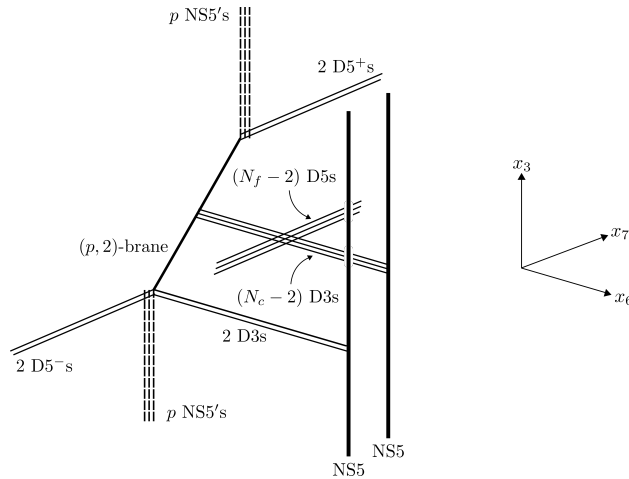

Matter Content:

$N_f - 2$ flavours of massless matter transforming in the fundamental of $U(N_c - 2)$.

$N_f - 2$ flavours of massless antimatter transforming in the antifundamental of $U(N_c - 2)$.

Two flavours of massive matter, with mass m , transforming in the fundamental of $U(N_c - 2)$.

Two flavours of massive antimatter, with mass m , transforming in the antifundamental of $U(N_c - 2)$.

$N_f - 2$ flavours of massive matter, with mass m , transforming in the fundamental of $U(2)$.

$N_f - 2$ flavours of massive antimatter, with mass $-m$, transforming in the antifundamental of $U(2)$.

Two flavours of massive matter, with mass $2m$, transforming in the fundamental of $U(2)$.

Two flavours of massless antimatter transforming in the antifundamental of $U(2)$.

Aharony and Giveon-Kutasov Duality:

The high energy theory is:

$$U(N_c - 2)_k \times U(2)_k \tag{8.34}$$

with the matter content as listed in the box above. The low energy theory is:

$$U(N_c - 2)_{k+2} \times U(2)_{k+1} \tag{8.35}$$

with only the massless content of the box above.

Dualities:

$k = -2$) The high energy theory is $U(N_c - 2)_{-2} \times U(2)_{-2}$, the low energy theory is $U(N_c - 2)_0 \times U(2)_{-1}$. The $U(N_c - 2)$ gauge theory exhibits a flow from Giveon-Kutasov to Aharony Duality. The $U(2)$ gauge theory exhibits no flows between dualities, and is Giveon-Kutasov dual at low energies.

$k = -1$) The high energy theory is $U(N_c - 2)_{-1} \times U(2)_{-1}$, the low energy theory is $U(N_c - 2)_1 \times U(2)_0$. The $U(N_c - 2)$ gauge theory exhibits no flow in dualities, and is Giveon-Kutasov dual at low energies. The $U(2)$ gauge theory exhibits a flow from Giveon-Kutasov to Aharony duality.

$k = 0$) The high energy theory is $U(N_c - 2)_0 \times U(2)_0$. The low energy theory is $U(N_c - 2)_2 \times U(2)_1$. Both gauge groups exhibit a flow from Aharony to Giveon-Kutasov Duality.

$k \neq -2, -1, 0$) In this case there is no flow between dualities, and both gauge groups exhibit Giveon-Kutasov duality at low energies.

8.2.6 One D3-brane Displaced Upwards and One D3-brane Displaced Downwards

Take the $(N_c - 1)^{\text{th}}$ brane to be displaced in the negative x_3 -direction and the N_c^{th} D3-brane to be displaced in the positive x_3 -direction: The D5-branes labelled by the flavour indices $1, \dots, N_f - 2$ are at $x_3 = 0$, corresponding to $m_1, m_2, \dots, m_{N_f - 2}^{N_f - 2} = \tilde{m}_1, \tilde{m}_2, \dots, \tilde{m}_{N_f - 2}^{N_f - 2} = 0$. The $(N_f - 1)^{\text{th}}$ and N_f^{th} D5-branes are displaced and split into two $D5^+$ s at $x_3 = m$ and two $D5^-$ s at $x_3 = -m$, corresponding to $m_{N_f - 1}^{N_f - 1} = m_{N_f}^{N_f} = \tilde{m}_{N_f - 1}^{N_f - 1} = \tilde{m}_{N_f}^{N_f} = m$. The D3-branes labelled by the colour indices $1, \dots, N_c - 2$ are at $x_3 = 0$, corresponding to $\sigma_1^1, \sigma_2^2, \dots, \sigma_{N_c - 2}^{N_c - 2} = 0$. Lastly, the $(N_c - 1)^{\text{th}}$ D3-brane is at $x_3 = -m$ corresponding to $\sigma_{N_c - 1}^{N_c - 1} = m$ and the N_c^{th} D3-brane is at $x_3 = m$ corresponding to $\sigma_{N_c}^{N_c} = -m$. The configuration is given by:

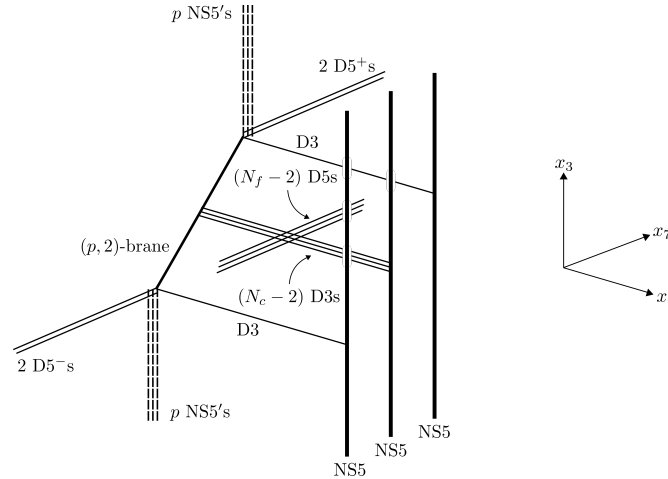

Matter Content:

$N_f - 2$ flavours of massless matter transforming in the fundamental of $U(N_c - 2)$.

$N_f - 2$ flavours of massless antimatter transforming in the antifundamental of $U(N_c - 2)$.

Two flavours of massive matter, with mass m , transforming in the fundamental of $U(N_c - 2)$.

Two flavours of massive antimatter, with mass m , transforming in the antifundamental of $U(N_c - 2)$.

$N_f - 2$ flavours of massive matter, with mass m , transforming in the fundamental of $U(1)$.

$N_f - 2$ flavours of massive antimatter, with mass $-m$, transforming in the antifundamental of $U(1)$.

Two flavours of massive matter, with mass $2m$, transforming in the fundamental of $U(1)$.

Two flavours of massless antimatter transforming in the antifundamental of $U(1)$.

$N_f - 2$ flavours of massive matter, with mass $-m$, transforming in the fundamental of $U(1)$.

$N_f - 2$ flavours of massive antimatter, with mass m , transforming in the antifundamental of $U(1)$.

Two flavours of massless matter transforming in the fundamental of $U(1)$.

Two flavours of massive antimatter, with mass $2m$ transforming in the antifundamental of $U(1)$.

Aharony and Giveon-Kutasov Duality:

The high energy theory is:

$$U(N_c - 2)_k \times U(1)_k \times U(1)_k \tag{8.36}$$

with the matter content as listed in the box above. The low energy theory is:

$$U(N_c - 2)_{k+2} \times U(1)_{k+1} \times U(1)_{k+1} \tag{8.37}$$

with only the massless content of the box above.

Dualities:

$k = -2$) The high energy theory is $U(N_c - 2)_{-2} \times U(1)_{-2} \times U(1)_{-2}$, the low energy theory is $U(N_c - 2)_0 \times U(1)_{-1} \times U(1)_{-1}$. The $U(N_c - 2)$ gauge theory exhibits a flow from Giveon-Kutasov to Aharony Duality. The $U(1)$ gauge theories exhibit no flows between dualities, and is Giveon-Kutasov dual at low energies.

$k = -1$) The high energy theory is $U(N_c - 2)_{-1} \times U(1)_{-1} \times U(1)_{-1}$, the low energy theory is $U(N_c - 2)_1 \times U(1)_0 \times U(1)_0$. The $U(N_c - 2)$ gauge theory exhibits no flow in dualities, and is Giveon-Kutasov dual at low energies. The $U(1)$ gauge theories exhibit a flow from Giveon-Kutasov to Aharony duality.

$k = 0$) The high energy theory is $U(N_c - 2)_0 \times U(1)_0 \times U(1)_0$. The low energy theory is $U(N_c - 2)_2 \times U(1)_1 \times U(1)_1$. All gauge groups exhibit a flow from Aharony to Giveon-Kutasov Duality.

$k \neq -2, -1, 0$) In this case there is no flow between dualities, and both gauge groups exhibit Giveon-Kutasov duality at low energies.

8.2.7 Two D3-branes Displaced Upwards and One D3-brane Displaced Downwards

Take the $(N_c - 2)^{\text{th}}$ brane to be displaced in the negative x_3 -direction and the $(N_c - 1)^{\text{th}}$ and the N_c^{th} D3-branes to be displaced in the positive x_3 -direction: The D5-branes labelled by the flavour indices $1, \dots, N_f - 2$ are at $x_3 = 0$, corresponding to $m_1^1, m_2^2, \dots, m_{N_f-2}^{N_f-2} = \tilde{m}_1^1, \tilde{m}_2^2, \dots, \tilde{m}_{N_f-2}^{N_f-2} = 0$. The $(N_f - 1)^{\text{th}}$ and N_f^{th} D5-branes are displaced and split into two D5⁺s at $x_3 = m$ and two D5⁻s at $x_3 = -m$, corresponding to $m_{N_f-1}^{N_f-1} = m_{N_f}^{N_f} = \tilde{m}_{N_f-1}^{N_f-1} = \tilde{m}_{N_f}^{N_f} = m$. The D3-branes labelled by the colour indices $1, \dots, N_c - 3$ are at $x_3 = 0$, corresponding to $\sigma_1^1, \sigma_2^2, \dots, \sigma_{N_c-3}^{N_c-3} = 0$. The $(N_c - 2)^{\text{th}}$ D3-brane is at $x_3 = -m$ corresponding to $\sigma_{N_c-2}^{N_c-2} = m$. Lastly, the $(N_c - 1)^{\text{th}}$ and the N_c^{th} D3-branes are at $x_3 = m$ corresponding to $\sigma_{N_c-1}^{N_c-1} = \sigma_{N_c}^{N_c} = -m$. The configuration is given by:

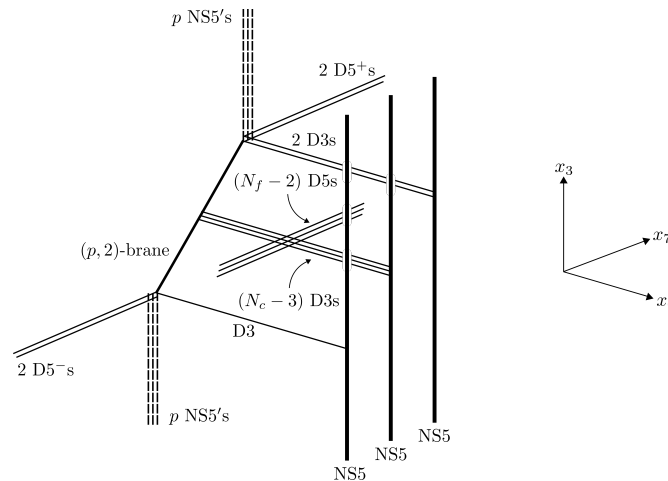

Matter Content:

$N_f - 2$ flavours of massless matter transforming in the fundamental of $U(N_c - 3)$.

$N_f - 2$ flavours of massless antimatter transforming in the antifundamental of $U(N_c - 3)$.

Two flavours of massive matter, with mass m , transforming in the fundamental of $U(N_c - 3)$.

Two flavours of massive antimatter, with mass m , transforming in the antifundamental of $U(N_c - 3)$.

$N_f - 2$ flavours of massive matter, with mass m , transforming in the fundamental of $U(1)$.

$N_f - 2$ flavours of massive antimatter, with mass $-m$, transforming in the antifundamental of $U(1)$.

Two flavours of massive matter, with mass $2m$, transforming in the fundamental of $U(1)$.

Two flavours of massless antimatter transforming in the antifundamental of $U(1)$.

$N_f - 2$ flavours of massive matter, with mass $-m$, transforming in the fundamental of $U(2)$.

$N_f - 2$ flavours of massive antimatter, with mass m , transforming in the antifundamental of $U(2)$.

Two flavours of massless matter transforming in the fundamental of $U(2)$.

Two flavours of massive antimatter, with mass $2m$ transforming in the antifundamental of $U(2)$.

Aharony and Giveon-Kutasov Duality:

The high energy theory is:

$$U(N_c - 3)_k \times U(1)_k \times U(2)_k \tag{8.38}$$

with the matter content as listed in the box above. The low energy theory is:

$$U(N_c - 3)_{k+2} \times U(1)_{k+1} \times U(2)_{k+1} \tag{8.39}$$

with only the massless content of the box above.

Dualities:

$k = -2$) The high energy theory is $U(N_c - 3)_{-2} \times U(1)_{-2} \times U(2)_{-2}$, the low energy theory is $U(N_c - 3)_0 \times U(1)_{-1} \times U(2)_{-1}$. The $U(N_c - 3)$ gauge theory exhibits a flow from Giveon-Kutasov to Aharony Duality. The $U(1)$ and $U(2)$ gauge theories exhibit no flows between dualities, and are Giveon-Kutasov dual at low energies.

$k = -1$) The high energy theory is $U(N_c - 3)_{-1} \times U(1)_{-1} \times U(2)_{-1}$, the low energy theory is $U(N_c - 3)_1 \times U(1)_0 \times U(2)_0$. The $U(N_c - 3)$ gauge theory exhibits no flow in dualities, and is Giveon-Kutasov dual at low energies. The $U(1)$ and $U(2)$ gauge theories exhibit a flow from Giveon-Kutasov to Aharony duality.

$k = 0$) The high energy theory is $U(N_c - 3)_0 \times U(1)_0 \times U(2)_0$. The low energy theory is $U(N_c - 3)_2 \times U(1)_1 \times U(2)_1$. All gauge groups exhibit a flow from Aharony to Giveon-Kutasov Duality.

$k \neq -2, -1, 0$) In this case there is no flow between dualities, and both gauge groups exhibit Giveon-Kutasov duality at low energies.

8.2.8 Two D3-branes Displaced Downwards and One D3-brane Displaced Upwards

Take the $(N_c - 2)^{\text{th}}$ brane to be displaced in the positive x_3 -direction and the $(N_c - 1)^{\text{th}}$ and the N_c^{th} D3-branes to be displaced in the negative x_3 -direction: The D5-branes labelled by the flavour indices $1, \dots, N_f - 2$ are at $x_3 = 0$, corresponding to $m_1, m_2, \dots, m_{N_f-2}^{N_f-2} = \tilde{m}_1, \tilde{m}_2, \dots, \tilde{m}_{N_f-2}^{N_f-2} = 0$. The $(N_f - 1)^{\text{th}}$ and N_f^{th} D5-branes are displaced and split into two D5⁺s at $x_3 = m$ and two D5⁻s at $x_3 = -m$, corresponding to $m_{N_f-1}^{N_f-1} = m_{N_f}^{N_f} = \tilde{m}_{N_f-1}^{N_f-1} = \tilde{m}_{N_f}^{N_f} = m$. The D3-branes labelled by the colour indices $1, \dots, N_c - 3$ are at $x_3 = 0$, corresponding to $\sigma_1^1, \sigma_2^2, \dots, \sigma_{N_c-3}^{N_c-3} = 0$. The $(N_c - 2)^{\text{th}}$ D3-brane is at $x_3 = m$ corresponding to $\sigma_{N_c-2}^{N_c-2} = -m$. Lastly, the $(N_c - 1)^{\text{th}}$ and the N_c^{th} D3-branes are at $x_3 = -m$ corresponding to $\sigma_{N_c-1}^{N_c-1} = \sigma_{N_c}^{N_c} = m$. The configuration is given by:

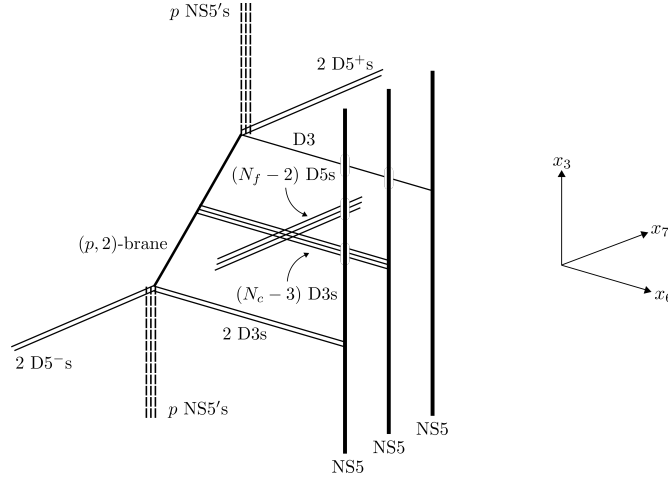

Matter Content:

$N_f - 2$ flavours of massless matter transforming in the fundamental of $U(N_c - 3)$.

$N_f - 2$ flavours of massless antimatter transforming in the antifundamental of $U(N_c - 3)$.

Two flavours of massive matter, with mass m , transforming in the fundamental of $U(N_c - 3)$.

Two flavours of massive antimatter, with mass m , transforming in the antifundamental of $U(N_c - 3)$.

$N_f - 2$ flavours of massive matter, with mass m , transforming in the fundamental of $U(2)$.

$N_f - 2$ flavours of massive antimatter, with mass $-m$, transforming in the antifundamental of $U(2)$.

Two flavours of massive matter, with mass $2m$, transforming in the fundamental of $U(2)$.

Two flavours of massless antimatter transforming in the antifundamental of $U(2)$.

$N_f - 2$ flavours of massive matter, with mass $-m$, transforming in the fundamental of $U(1)$.

$N_f - 2$ flavours of massive antimatter, with mass m , transforming in the antifundamental of $U(1)$.

Two flavours of massless matter transforming in the fundamental of $U(1)$.

Two flavours of massive antimatter, with mass $2m$ transforming in the antifundamental of $U(1)$.

Aharony and Giveon-Kutasov Duality:

The high energy theory is:

$$U(N_c - 3)_k \times U(2)_k \times U(1)_k \tag{8.40}$$

with the matter content as listed in the box above. The low energy theory is:

$$U(N_c - 3)_{k+2} \times U(2)_{k+1} \times U(1)_{k+1} \tag{8.41}$$

with only the massless content of the box above.

Dualities:

$k = -2$) The high energy theory is $U(N_c - 3)_{-2} \times U(2)_{-2} \times U(1)_{-2}$, the low energy theory is $U(N_c - 3)_0 \times U(2)_{-1} \times U(1)_{-1}$. The $U(N_c - 3)$ gauge theory exhibits a flow from Giveon-Kutasov to Aharony Duality. The $U(1)$ and $U(2)$ gauge theories exhibit no flows between dualities, and are Giveon-Kutasov dual at low energies.

$k = -1$) The high energy theory is $U(N_c - 3)_{-1} \times U(2)_{-1} \times U(1)_{-1}$, the low energy theory is $U(N_c - 3)_1 \times U(2)_0 \times U(1)_0$. The $U(N_c - 3)$ gauge theory exhibits no flow in dualities, and is Giveon-Kutasov dual at low energies. The $U(1)$ and $U(2)$ gauge theories exhibit a flow from Giveon-Kutasov to Aharony duality.

$k = 0$) The high energy theory is $U(N_c - 3)_0 \times U(2)_0 \times U(1)_0$. The low energy theory is $U(N_c - 3)_2 \times U(2)_1 \times U(1)_1$. All gauge groups exhibit a flow from Aharony to Giveon-Kutasov Duality.

$k \neq -2, -1, 0$) In this case there is no flow between dualities, and both gauge groups exhibit Giveon-Kutasov duality at low energies.

8.2.9 Two D3-branes Displaced Upwards and Two D3-branes Displaced Downwards

Take the $(N_c - 3)^{\text{th}}$ D3-brane and the $(N_c - 2)^{\text{th}}$ D3-brane to be displaced in the positive x_3 -direction, and take the $(N_c - 1)^{\text{th}}$ D3-brane and the N_c^{th} D3-brane to be displaced in the negative x_3 -direction: The D5-branes labelled by the flavour indices $1, \dots, N_f - 2$ are at $x_3 = 0$, corresponding to $m_1^1, m_2^2, \dots, m_{N_f-2}^{N_f-2} = \tilde{m}_1^1, \tilde{m}_2^2, \dots, \tilde{m}_{N_f-2}^{N_f-2} = 0$. The $(N_f - 1)^{\text{th}}$ and N_f^{th} D5-branes are

displaced and split into two $D5^+$ s at $x_3 = m$ and two $D5^-$ s at $x_3 = -m$, corresponding to $m_{N_f-1}^{N_f-1} = m_{N_f}^{N_f} = \tilde{m}_{N_f-1}^{N_f-1} = \tilde{m}_{N_f}^{N_f} = m$. The D3-branes labelled by the colour indices $1, \dots, N_c - 4$ are at $x_3 = 0$, corresponding to $\sigma_1^1, \sigma_2^2, \dots, \sigma_{N_c-4}^{N_c-4} = 0$. The $(N_c - 3)^{\text{th}}$ and the $(N_c - 2)^{\text{th}}$ D3-branes are at $x_3 = m$ corresponding to $\sigma_{N_c-3}^{N_c-3} = \sigma_{N_c-2}^{N_c-2} = -m$. Lastly, the $(N_c - 1)^{\text{th}}$ and the N_c^{th} D3-branes are at $x_3 = -m$ corresponding to $\sigma_{N_c-1}^{N_c-1} = \sigma_{N_c}^{N_c} = m$. The configuration is given by:

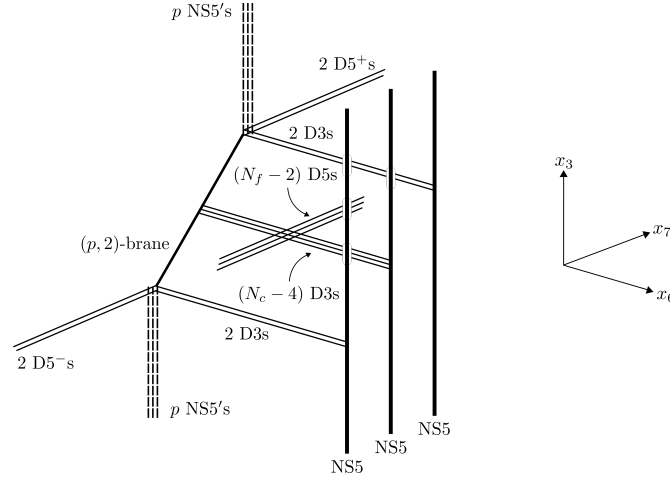

Matter Content:

$N_f - 2$ flavours of massless matter transforming in the fundamental of $U(N_c - 4)$.

$N_f - 2$ flavours of massless antimatter transforming in the antifundamental of $U(N_c - 4)$.

Two flavours of massive matter, with mass m , transforming in the fundamental of $U(N_c - 4)$.

Two flavours of massive antimatter, with mass m , transforming in the antifundamental of $U(N_c - 4)$.

$N_f - 2$ flavours of massive matter, with mass m , transforming in the fundamental of $U(2)$.

$N_f - 2$ flavours of massive antimatter, with mass $-m$, transforming in the antifundamental of $U(2)$.

Two flavours of massive matter, with mass $2m$, transforming in the fundamental of $U(2)$.

Two flavours of massless antimatter transforming in the antifundamental of $U(2)$.

$N_f - 2$ flavours of massive matter, with mass $-m$, transforming in the fundamental of $U(2)$.

$N_f - 2$ flavours of massive antimatter, with mass m , transforming in the antifundamental of $U(2)$.

Two flavours of massless matter transforming in the fundamental of $U(2)$.

Two flavours of massive antimatter, with mass $2m$ transforming in the antifundamental of $U(2)$.

Aharony and Giveon-Kutasov Duality:

The high energy theory is:

$$U(N_c - 4)_k \times U(2)_k \times U(2)_k \tag{8.42}$$

with the matter content as listed in the box above. The low energy theory is:

$$U(N_c - 4)_{k+2} \times U(2)_{k+1} \times U(2)_{k+1} \tag{8.43}$$

with only the massless content of the box above.

Dualities:

$k = -2$) The high energy theory is $U(N_c - 4)_{-2} \times U(2)_{-2} \times U(2)_{-2}$, the low energy theory is $U(N - 4)_0 \times U(2)_{-1} \times U(2)_{-1}$. The $U(N_c - 3)$ gauge theory exhibits a flow from Giveon-Kutasov to Aharony Duality. The $U(2)$ gauge theories exhibit no flows between dualities, and are Giveon-Kutasov dual at low energies.

$k = -1$) The high energy theory is $U(N_c - 4)_{-1} \times U(2)_{-1} \times U(2)_{-1}$, the low energy theory is $U(N - 4)_1 \times U(2)_0 \times U(2)_0$. The $U(N_c - 4)$ gauge theory exhibits no flow in dualities, and is Giveon-Kutasov dual at low energies. The $U(2)$ gauge theories exhibit a flow from Giveon-Kutasov to Aharony duality.

$k = 0$) The high energy theory is $U(N_c - 4)_0 \times U(2)_0 \times U(2)_0$. The low energy theory is $U(N_c - 4)_2 \times U(2)_1 \times U(2)_1$. All gauge groups exhibit a flow from Aharony to Giveon-Kutasov Duality.

$k \neq -2, -1, 0$) In this case there is no flow between dualities, and both gauge groups exhibit Giveon-Kutasov duality at low energies.

8.3 Two Displaced Flavour Branes, Displaced by Different Amounts

As a generalisation of the previous section, the two displaced D5-branes can be displaced by different amounts in the x_3 -direction. This is achieved by using an extended web of branes. One D5⁺ is displaced in the positive x_3 -direction by m_2 , and the second D5⁺ brane is displaced in the positive x_3 -direction by m_1 , where $m_1 > m_2$. Similarly, one D5⁻ is displaced in the negative x_3 -direction by m_2 , and the second D5⁻ brane is displaced in the negative x_3 -direction by m_1 . In this context, the subscripts 1 and 2 are not flavour or colour indices, they are simply there to show that the displacements are of different size. For brevity, only the results will be stated.

8.3.1 No Displaced D3-branes

The D5-branes labelled by the flavour indices $1, \dots, N_f - 2$ are at $x_3 = 0$, corresponding to $m_1^1, m_2^2, \dots, m_{N_f-2}^{N_f-2} = \tilde{m}_1^1, \tilde{m}_2^2, \dots, \tilde{m}_{N_f-2}^{N_f-2} = 0$. The $(N_f - 1)^{\text{th}}$ D5-brane is displaced and split into a D5⁺ at $x_3 = m_2$ and a D5⁻ at $x_3 = -m_2$, corresponding to $m_{N_f-1}^{N_f-1} = \tilde{m}_{N_f-1}^{N_f-1} = m_2$. The N_f^{th} D5-brane is displaced and split into a D5⁺ at $x_3 = m_1$ and a D5⁻ at $x_3 = -m_1$, corresponding to $m_{N_f}^{N_f} = \tilde{m}_{N_f}^{N_f} = m_1$, where $m_1 > m_2$. The D3-branes labelled by the colour indices $1, \dots, N_c$ are at $x_3 = 0$, corresponding to $\sigma_1^1, \sigma_2^2, \dots, \sigma_{N_c}^{N_c} = 0$. The configuration is given by:

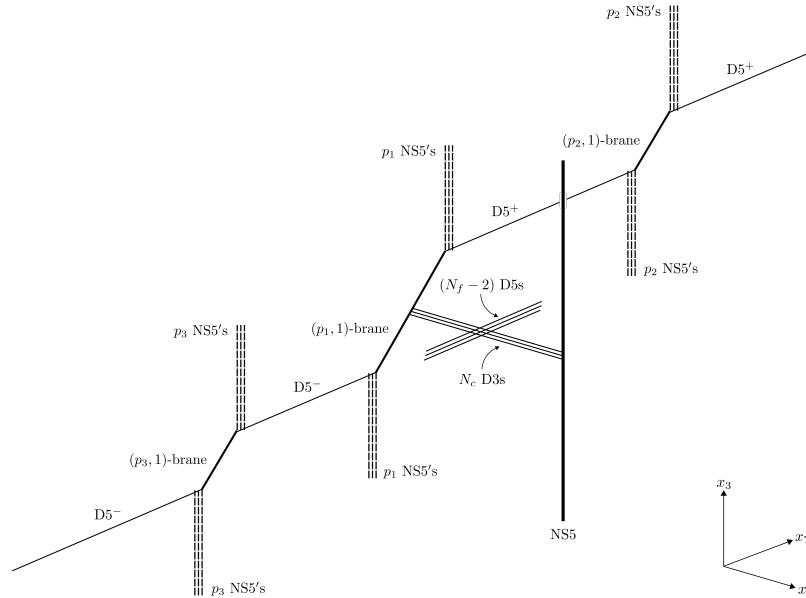

Matter Content:

One flavour of massive matter, with mass m_1 , in the fundamental of $U(N_c)$.

One flavour of massive matter, with mass m_2 , in the fundamental of $U(N_c)$.

$N_f - 2$ flavours of massless matter in the fundamental of $U(N_c)$.

$N_f - 2$ flavours of massless antimatter in the antifundamental of $U(N_c)$.

One flavour of massive antimatter, with mass m_2 , in the antifundamental of $U(N_c)$.

One flavour of massive antimatter, with mass m_1 , in the antifundamental of $U(N_c)$.

Aharony and Giveon-Kutasov Duality:

The high energy theory contains the massive and massless matter and antimatter listed above, transforming in the gauge group:

$$U(N_c)_k \tag{8.44}$$

The low energy theory contains the massless matter and antimatter listed above, transforming in the gauge group:

$$U(N_c)_{k+2} \tag{8.45}$$

$k = -2$) The $U(N_c)$ group exhibits a flow from Giveon-Kutasov to Aharony duality.

$k = 0$) The $U(N_c)$ group exhibits a flow from Aharony duality to Giveon-Kutasov.

$k \neq -2, 0$) The $U(N_c)$ group exhibits no flow between dualities, and Giveon-Kutasov duality at low energies.

8.3.2 One D3-brane Dislaced Upwards to $x_3 = m_1$

The D5-branes labelled by the flavour indices $1, \dots, N_f - 2$ are at $x_3 = 0$, corresponding to $m_1^1, m_2^2, \dots, m_{N_f-2}^{N_f-2} = \tilde{m}_1^1, \tilde{m}_2^2, \dots, \tilde{m}_{N_f-2}^{N_f-2} = 0$. The $(N_f - 1)^{\text{th}}$ D5-brane is displaced and split into a $D5^+$ at $x_3 = m_2$ and a $D5^-$ at $x_3 = -m_2$, corresponding to $m_{N_f-1}^{N_f-1} = \tilde{m}_{N_f-1}^{N_f-1} = m_2$. The N_f^{th} D5-brane is displaced and split into a $D5^+$ at $x_3 = m_1$ and a $D5^-$ at $x_3 = -m_1$, corresponding to $m_{N_f}^{N_f} = \tilde{m}_{N_f}^{N_f} = m_1$, where $m_1 > m_2$. The D3-branes labelled by the colour indices $1, \dots, N_c - 1$ are at $x_3 = 0$, corresponding to $\sigma_1^1, \sigma_2^2, \dots, \sigma_{N_c-1}^{N_c-1} = 0$. Lastly, the N_c^{th} D3-brane is at $x_3 = m_1$, corresponding to $\sigma_{N_c}^{N_c} = -m_1$. The configuration is given by:

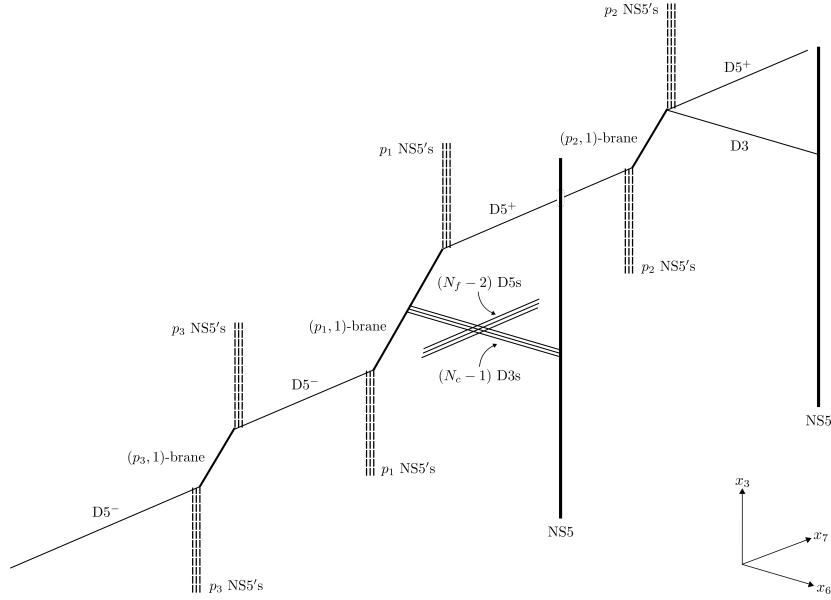

Matter Content:

One flavour of massless matter in the fundamental of $U(1)_{N_c}$.

One flavour of massive matter, with mass $m_2 - m_1 < 0$, in the fundamental of $U(1)_{N_c}$.

$N_f - 2$ flavours of massive matter, with mass $-m_1$, in the fundamental of $U(1)_{N_c}$.

$N_f - 2$ flavours of massive antimatter, with mass m_1 , in the antifundamental of $U(1)_{N_c}$.

One flavour of massive antimatter, with mass $m_1 + m_2$, in the antifundamental of $U(1)_{N_c}$.

One flavour of massive antimatter, with mass $2m_1$, in the antifundamental of $U(1)_{N_c}$.

One flavour of massive matter, with mass m_1 , in the fundamental of $U(N_c - 1)$.

One flavour of massive matter, with mass m_2 , in the fundamental of $U(N_c - 1)$.

$N_f - 2$ flavours of massless matter in the fundamental of $U(N_c - 1)$.

$N_f - 2$ flavours of massless antimatter in the antifundamental of $U(N_c - 1)$.

One flavour of massive antimatter, with mass m_2 , in the antifundamental of $U(N_c - 1)$.

One flavour of massive antimatter, with mass m_1 in the antifundamental of $U(N_c - 1)$.

Aharony and Gaiotto-Dvali Duality:

The high energy theory contains the massive and massless matter and antimatter listed above, transforming in the gauge group:

$$U(N_c - 1)_k \times U(1)_{N_c, k} \quad (8.46)$$

The low energy theory contains the massless matter and antimatter listed above, transforming in the gauge group:

$$U(N_c - 1)_{k+2} \times U(1)_{N_c, k + \frac{1}{2}} \quad (8.47)$$

$k = -2$) The $U(N_c - 1)$ group exhibits a flow from Giveon-Kutasov to Aharony duality. The $U(1)_{N_c}$ group exhibits no flow between dualities, and Giveon-Kutasov duality at low energies.

$k = -\frac{1}{2}$) The $U(N_c - 1)$ group exhibits no flow between dualities, and Giveon-Kutasov duality at low energies. The $U(1)_{N_c}$ group exhibits a flow from Giveon-Kutasov to Aharony duality.

$k = 0$) The $U(N_c)$ group and the $U(1)_{N_c}$ group exhibit a flow from Aharony duality to Giveon-Kutasov.

$k \neq -2, -\frac{1}{2}, 0$) The $U(N_c - 1)$ group and $U(1)_{N_c}$ groups exhibit no flow between dualities, and Giveon-Kutasov duality at low energies.

8.3.3 One D3-brane Displaced Upwards to $x_3 = m_2$

The D5-branes labelled by the flavour indices $1, \dots, N_f - 2$ are at $x_3 = 0$, corresponding to $m_1^1, m_2^2, \dots, m_{N_f-2}^{N_f-2} = \tilde{m}_1^1, \tilde{m}_2^2, \dots, \tilde{m}_{N_f-2}^{N_f-2} = 0$. The $(N_f - 1)^{\text{th}}$ D5-brane is displaced and split into a $D5^+$ at $x_3 = m_2$ and a $D5^-$ at $x_3 = -m_2$, corresponding to $m_{N_f-1}^{N_f-1} = \tilde{m}_{N_f-1}^{N_f-1} = m_2$. The N_f^{th} D5-brane is displaced and split into a $D5^+$ at $x_3 = m_1$ and a $D5^-$ at $x_3 = -m_1$, corresponding to $m_{N_f}^{N_f} = \tilde{m}_{N_f}^{N_f} = m_1$, where $m_1 > m_2$. The D3-branes labelled by the colour indices $1, \dots, N_c - 1$ are at $x_3 = 0$, corresponding to $\sigma_1^1, \sigma_2^2, \dots, \sigma_{N_c-1}^{N_c-1} = 0$. Lastly, the N_c^{th} D3-brane is at $x_3 = m_2$, corresponding to $\sigma_{N_c}^{N_c} = -m_2$. The configuration is given by:

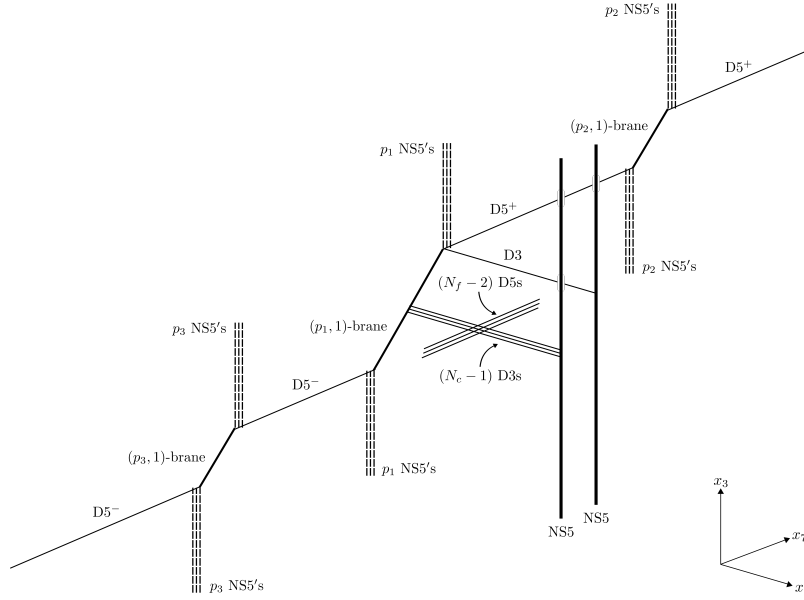

Matter Content:

One flavour of massless matter in the fundamental of $U(1)_{N_c}$.

One flavour of massive matter, with mass $m_1 - m_2 > 0$, in the fundamental of $U(1)_{N_c}$.

$N_f - 2$ flavours of massive matter, with mass $-m_2$, in the fundamental of $U(1)_{N_c}$.

$N_f - 2$ flavours of massive antimatter, with mass m_2 , in the antifundamental of $U(1)_{N_c}$.

One flavour of massive antimatter, with mass $m_1 + m_2$, in the antifundamental of $U(1)_{N_c}$.

One flavour of massive antimatter, with mass $2m_2$, in the antifundamental of $U(1)_{N_c}$.

One flavour of massive matter, with mass m_1 , in the fundamental of $U(N_c - 1)$.

One flavour of massive matter, with mass m_2 , in the fundamental of $U(N_c - 1)$.

$N_f - 2$ flavours of massless matter in the fundamental of $U(N_c - 1)$.

$N_f - 2$ flavours of massless antimatter in the antifundamental of $U(N_c - 1)$.

One flavour of massive antimatter, with mass m_2 , in the antifundamental of $U(N_c - 1)$.

One flavour of massive antimatter, with mass m_1 in the antifundamental of $U(N_c - 1)$.

Aharony and Giveon-Kutasov Duality:

The high energy theory contains the massive and massless matter and antimatter listed above, transforming in the gauge group:

$$U(N_c - 1)_k \times U(1)_{N_c, k} \quad (8.48)$$

The low energy theory contains the massless matter and antimatter listed above, transforming in the gauge group:

$$U(N_c - 1)_{k+2} \times U(1)_{N_c, k+\frac{3}{2}} \quad (8.49)$$

$k = -2$) The $U(N_c - 1)$ group exhibits a flow from Giveon-Kutasov to Aharony duality. The $U(1)_{N_c}$ group exhibits no flow between dualities, and Giveon-Kutasov duality at low energies.

$k = -\frac{3}{2}$) The $U(N_c - 1)$ group exhibits no flow between dualities, and Giveon-Kutasov duality at low energies. The $U(1)_{N_c}$ group exhibits a flow from Giveon-Kutasov to Aharony duality.

$k = 0$) The $U(N_c)$ group and the $U(1)_{N_c}$ group exhibit a flow from Aharony duality to Giveon-Kutasov.

$k \neq -2, -\frac{3}{2}, 0$) The $U(N_c - 1)$ group and $U(1)_{N_c}$ groups exhibit no flow between dualities, and Giveon-Kutasov duality at low energies.

8.3.4 One D3-brane Displaced Downwards to $x_3 = -m_2$

The D5-branes labelled by the flavour indices $1, \dots, N_f - 2$ are at $x_3 = 0$, corresponding to $m_1^1, m_2^2, \dots, m_{N_f-2}^{N_f-2} = \tilde{m}_1^1, \tilde{m}_2^2, \dots, \tilde{m}_{N_f-2}^{N_f-2} = 0$. The $(N_f - 1)^{\text{th}}$ D5-brane is displaced and split into a $D5^+$ at $x_3 = m_2$ and a $D5^-$ at $x_3 = -m_2$, corresponding to $m_{N_f-1}^{N_f-1} = \tilde{m}_{N_f-1}^{N_f-1} = m_2$. The N_f^{th} D5-brane is displaced and split into a $D5^+$ at $x_3 = m_1$ and a $D5^-$ at $x_3 = -m_1$, corresponding to $m_{N_f}^{N_f} = \tilde{m}_{N_f}^{N_f} = m_1$, where $m_1 > m_2$. The D3-branes labelled by the colour indices $1, \dots, N_c - 1$ are at $x_3 = 0$, corresponding to $\sigma_1^1, \sigma_2^2, \dots, \sigma_{N_c-1}^{N_c-1} = 0$. Lastly, the N_c^{th} D3-brane is at $x_3 = -m_2$, corresponding to $\sigma_{N_c}^{N_c} = m_2$. The configuration is given by:

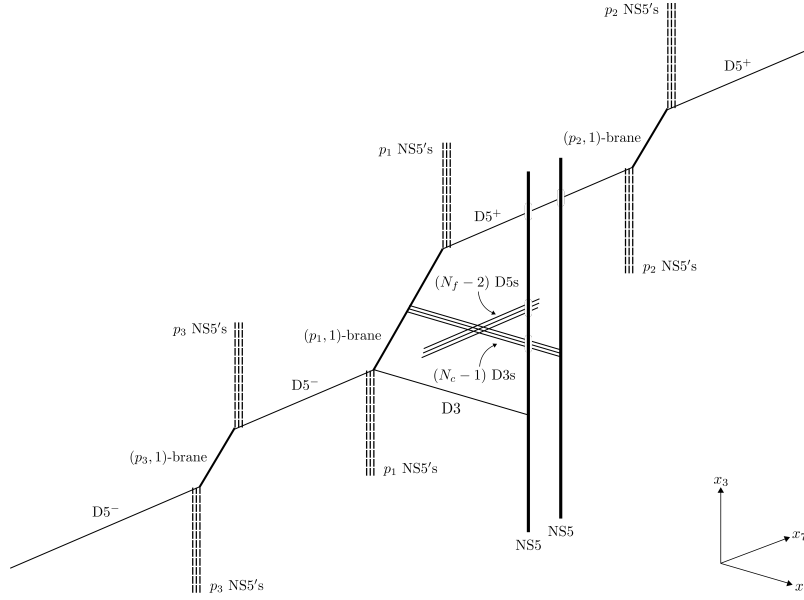

Matter Content:

One flavour of massive matter, with mass $m_1 + m_2$, in the fundamental of $U(1)_{N_c}$.

One flavour of massive matter, with mass $2m_2$, in the fundamental of $U(1)_{N_c}$.

$N_f - 2$ flavours of massive matter, with mass m_2 , in the fundamental of $U(1)_{N_c}$.

$N_f - 2$ flavours of massive antimatter, with mass $-m_2$, in the antifundamental of $U(1)_{N_c}$.

One flavour of massless antimatter in the antifundamental of $U(1)_{N_c}$.

One flavour of massive antimatter, with mass $m_1 - m_2 > 0$, in the antifundamental of $U(1)_{N_c}$.

One flavour of massive matter, with mass m_1 , in the fundamental of $U(N_c - 1)$.

One flavour of massive matter, with mass m_2 in the fundamental of $U(N_c - 1)$.

$N_f - 2$ flavours of massless matter in the fundamental of $U(N_c - 1)$.

$N_f - 2$ flavours of massless antimatter in the antifundamental of $U(N_c - 1)$.

One flavour of massive antimatter, with mass m_2 , in the antifundamental of $U(N_c - 1)$.

One flavour of massive antimatter, with mass m_1 , in the antifundamental of $U(N_c - 1)$.

Aharony and Giveon-Kutasov Duality:

The high energy theory contains the massive and massless matter and antimatter listed above, transforming in the gauge group:

$$U(N_c - 1)_k \times U(1)_{N_c, k} \quad (8.50)$$

The low energy theory contains the massless matter and antimatter listed above, transforming in the gauge group:

$$U(N_c - 1)_{k+2} \times U(1)_{N_c, k + \frac{3}{2}} \quad (8.51)$$

$k = -2$) The $U(N_c - 1)$ group exhibits a flow from Giveon-Kutasov to Aharony duality. The $U(1)_{N_c}$ group exhibits no flow between dualities, and Giveon-Kutasov duality at low energies.

$k = -\frac{3}{2}$) The $U(N_c - 1)$ group exhibits no flow between dualities, and Giveon-Kutasov duality at low energies. The $U(1)_{N_c}$ group exhibits a flow from Giveon-Kutasov to Aharony duality.

$k = 0$) The $U(N_c)$ group and the $U(1)_{N_c}$ group exhibit a flow from Aharony duality to Giveon-Kutasov.

$k \neq -2, -\frac{3}{2}, 0$) The $U(N_c - 1)$ group and $U(1)_{N_c}$ groups exhibit no flow between dualities, and Giveon-Kutasov duality at low energies.

8.3.5 One D3-brane Displaced Downwards to $x_3 = -m_1$

The D5-branes labelled by the flavour indices $1, \dots, N_f - 2$ are at $x_3 = 0$, corresponding to $m_1^1, m_2^2, \dots, m_{N_f-2}^{N_f-2} = \tilde{m}_1^1, \tilde{m}_2^2, \dots, \tilde{m}_{N_f-2}^{N_f-2} = 0$. The $(N_f - 1)^{\text{th}}$ D5-brane is displaced and split into a $D5^+$ at $x_3 = m_2$ and a $D5^-$ at $x_3 = -m_2$, corresponding to $m_{N_f-1}^{N_f-1} = \tilde{m}_{N_f-1}^{N_f-1} = m_2$. The N_f^{th} D5-brane is displaced and split into a $D5^+$ at $x_3 = m_1$ and a $D5^-$ at $x_3 = -m_1$, corresponding to $m_{N_f}^{N_f} = \tilde{m}_{N_f}^{N_f} = m_1$, where $m_1 > m_2$. The D3-branes labelled by the colour indices $1, \dots, N_c - 1$ are at $x_3 = 0$, corresponding to $\sigma_1^1, \sigma_2^2, \dots, \sigma_{N_c-1}^{N_c-1} = 0$. Lastly, the N_c^{th} D3-brane is at $x_3 = -m_1$, corresponding to $\sigma_{N_c}^{N_c} = m_1$. The configuration is given by:

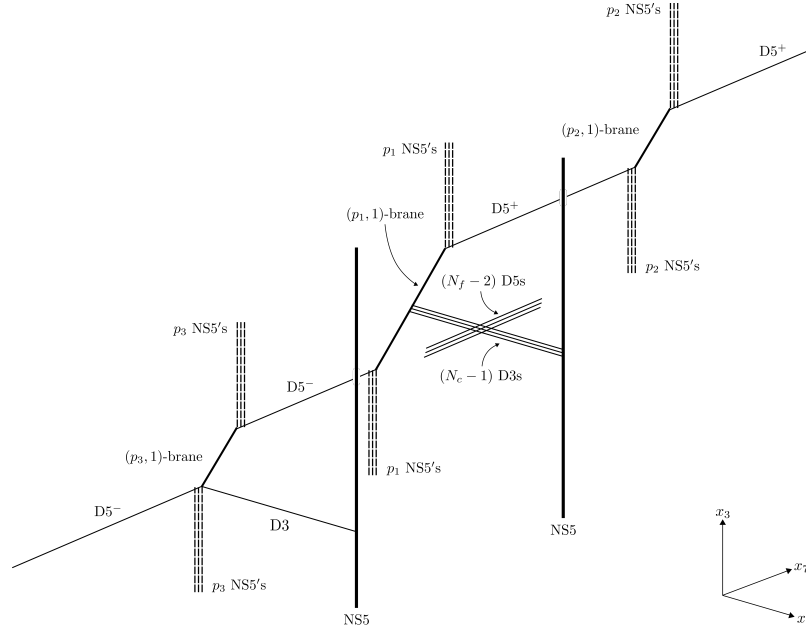

Matter Content:

- One flavour of massive matter, with mass $m_1 + m_2$, in the fundamental of $U(1)_{N_c}$.
- One flavour of massive matter, with mass $2m_1$, in the fundamental of $U(1)_{N_c}$.
- $N_f - 2$ flavours of massive matter, with mass m_1 , in the fundamental of $U(1)_{N_c}$.
- $N_f - 2$ flavours of massive antimatter, with mass $-m_1$, in the antifundamental of $U(1)_{N_c}$.
- One flavour of massless antimatter in the antifundamental of $U(1)_{N_c}$.
- One flavour of massive antimatter, with mass $m_2 - m_1 < 0$, in the anti-fundamental of $U(1)_{N_c}$.
- One flavour of massive matter, with mass m_1 , in the fundamental of $U(N_c - 1)$.
- One flavour of massive matter, with mass m_2 in the fundamental of $U(N_c - 1)$.
- $N_f - 2$ flavours of massless matter in the fundamental of $U(N_c - 1)$.
- $N_f - 2$ flavours of massless antimatter in the antifundamental of $U(N_c - 1)$.
- One flavour of massive antimatter, with mass m_2 , in the antifundamental of $U(N_c - 1)$.
- One flavour of massive antimatter, with mass m_1 , in the antifundamental of $U(N_c - 1)$.

Aharony and Giveon-Kutasov Duality:

The high energy theory contains the massive and massless matter and antimatter listed above, transforming in the gauge group:

$$U(N_c - 1)_k \times U(1)_{N_c, k} \quad (8.52)$$

The low energy theory contains the massless matter and antimatter listed above, transforming in the gauge group:

$$U(N_c - 1)_{k+2} \times U(1)_{N_c, k+\frac{1}{2}} \quad (8.53)$$

$k = -2$) The $U(N_c - 1)$ group exhibits a flow from Giveon-Kutasov to Aharony duality. The $U(1)_{N_c}$ group exhibits no flow between dualities, and Giveon-Kutasov duality at low energies.

$k = -\frac{1}{2}$) The $U(N_c - 1)$ group exhibits no flow between dualities, and Giveon-Kutasov duality at low energies. The $U(1)_{N_c}$ group exhibits a flow from Giveon-Kutasov to Aharony duality.

$k = 0$) The $U(N_c)$ group and the $U(1)_{N_c}$ group exhibit a flow from Aharony duality to Giveon-Kutasov.

$k \neq -2, -\frac{1}{2}, 0$) The $U(N_c - 1)$ group and $U(1)_{N_c}$ groups exhibit no flow between dualities, and Giveon-Kutasov duality at low energies.

8.3.6 One D3-brane Displaced Upwards to $x_3 = m_1$ and One D3-brane Displaced Upwards to $x_3 = m_2$

The D5-branes labelled by the flavour indices $1, \dots, N_f - 2$ are at $x_3 = 0$, corresponding to $m_1^1, m_2^2, \dots, m_{N_f-2}^{N_f-2} = \tilde{m}_1^1, \tilde{m}_2^2, \dots, \tilde{m}_{N_f-2}^{N_f-2} = 0$. The $(N_f - 1)^{\text{th}}$ D5-brane is displaced and split into a $D5^+$ at $x_3 = m_2$ and a $D5^-$ at $x_3 = -m_2$, corresponding to $m_{N_f-1}^{N_f-1} = \tilde{m}_{N_f-1}^{N_f-1} = m_2$. The N_f^{th} D5-brane is displaced and split into a $D5^+$ at $x_3 = m_1$ and a $D5^-$ at $x_3 = -m_1$, corresponding to $m_{N_f}^{N_f} = \tilde{m}_{N_f}^{N_f} = m_1$, where $m_1 > m_2$. The D3-branes labelled by the colour indices $1, \dots, N_c - 2$ are at $x_3 = 0$, corresponding to $\sigma_1^1, \sigma_2^2, \dots, \sigma_{N_c-2}^{N_c-2} = 0$. The $(N_c - 1)^{\text{th}}$ D3-brane is at $x_3 = m_2$, corresponding to $\sigma_{N_c-1}^{N_c-1} = -m_2$. Lastly, the N_c^{th} D3-brane is at $x_3 = m_1$, corresponding to $\sigma_{N_c}^{N_c} = -m_1$. The configuration is given by:

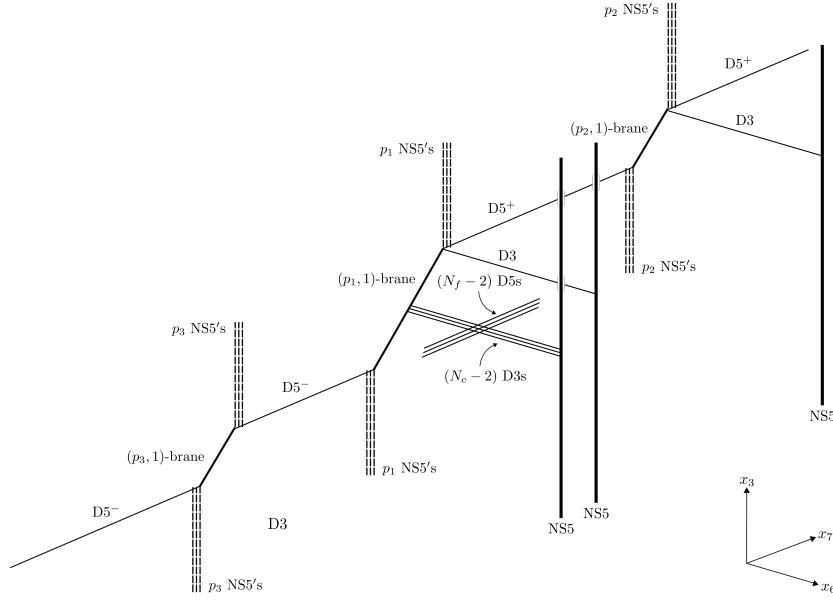

Matter Content:

One flavour of massless matter in the fundamental of $U(1)_{N_c}$.

One flavour of massive matter, with mass $m_2 - m_1 < 0$, in the fundamental of $U(1)_{N_c}$.

$N_f - 2$ flavours of massive matter, with mass $-m_1$, in the fundamental of $U(1)_{N_c}$.

$N_f - 2$ flavours of massive antimatter, with mass m_1 , in the antifundamental of $U(1)_{N_c}$.

One flavour of massive antimatter, with mass $m_1 + m_2$, in the antifundamental of $U(1)_{N_c}$.

One flavour of massive antimatter, with mass $2m_1$, in the antifundamental of $U(1)_{N_c}$.

One flavour of massive matter, with mass $m_1 - m_2 > 0$, in the fundamental of $U(1)_{N_c-1}$.

One flavour of massless matter in fundamental of $U(1)^{N_c-1}$.

$N_f - 2$ flavours of massive matter, with mass $-m_2$, in the fundamental of $U(1)_{N_c-1}$.

$N_f - 2$ flavours of massive antimatter, with mass m_2 , in the antifundamental of $U(1)_{N_c-1}$.

One flavour of massive antimatter, with mass $2m_2$, in the antifundamental of $U(1)_{N_c-1}$.

One flavour of massive antimatter, with mass $m_1 + m_2$, in the antifundamental of $U(1)_{N_c-1}$.

One flavour of massive matter, with mass m_1 , in the fundamental of $U(N_c - 2)$.

One flavour of massive matter, with mass m_2 , in the fundamental of $U(N_c - 2)$.

$N_f - 2$ flavours of massless matter in the fundamental of $U(N_c - 2)$.

$N_f - 2$ flavours of massless antimatter in the antifundamental of $U(N_c - 2)$.

One flavour of massive antimatter, with mass m_2 , in the antifundamental of $U(N_c - 2)$.

One flavour of massive antimatter, with mass m_1 , in the antifundamental of $U(N_c - 2)$.

Aharony and Giveon-Kutasov Duality:

The high energy theory contains the massive and massless matter and antimatter listed above, transforming in the gauge group:

$$U(N_c - 2)_k \times U(1)_{N_c-1,k} \times U(1)_{N_c,k} \quad (8.54)$$

The low energy theory contains the massless matter and antimatter listed above, transforming in the gauge group:

$$U(N_c - 2)_{k+2} \times U(1)_{N_c-1,k+\frac{3}{2}} \times U(1)_{N_c,k+\frac{1}{2}} \quad (8.55)$$

$k = -2$) The $U(N_c - 2)$ group exhibits a flow from Giveon-Kutasov to Aharony duality. The two $U(1)$ groups exhibit no flow between dualities, and Giveon-Kutasov duality at low energies.

$k = -\frac{3}{2}$) The $U(1)_{N_c-1}$ gauge group exhibits a flow from Giveon-Kutasov to Aharony duality. The other gauge groups exhibit no flow between dualities, and Giveon-Kutasov duality at low energies.

$k = -\frac{1}{2}$) The $U(1)_{N_c}$ gauge group exhibits a flow from Giveon-Kutasov to Aharony duality. The other gauge groups exhibit no flow between dualities, and Giveon-Kutasov duality at low energies.

$k = 0$) All gauge groups exhibit a flow from Aharony duality to Giveon-Kutasov.

$k \neq -2, -\frac{3}{2}, -\frac{1}{2}, 0$) All gauge groups exhibit no flow between dualities, and Giveon-Kutasov duality at low energies.

8.3.7 One D3-brane Displaced Downwards to $x_3 = -m_1$ and One D3-brane Displaced Downwards to $x_3 = -m_2$

The D5-branes labelled by the flavour indices $1, \dots, N_f - 2$ are at $x_3 = 0$, corresponding to $m_1^1, m_2^2, \dots, m_{N_f-2}^{N_f-2} = \tilde{m}_1^1, \tilde{m}_2^2, \dots, \tilde{m}_{N_f-2}^{N_f-2} = 0$. The $(N_f - 1)^{\text{th}}$ D5-brane is displaced and split into a $D5^+$ at $x_3 = m_2$ and a $D5^-$ at $x_3 = -m_2$, corresponding to $m_{N_f-1}^{N_f-1} = \tilde{m}_{N_f-1}^{N_f-1} = m_2$. The N_f^{th} D5-brane is displaced and split into a $D5^+$ at $x_3 = m_1$ and a $D5^-$ at $x_3 = -m_1$, corresponding to $m_{N_f}^{N_f} = \tilde{m}_{N_f}^{N_f} = m_1$, where $m_1 > m_2$. The D3-branes labelled by the colour indices $1, \dots, N_c - 2$ are at $x_3 = 0$, corresponding to $\sigma_1^1, \sigma_2^2, \dots, \sigma_{N_c-2}^{N_c-2} = 0$. The $(N_c - 1)^{\text{th}}$ D3-brane is at $x_3 = -m_2$, corresponding to $\sigma_{N_c-1}^{N_c-1} = m_2$. Lastly, the N_c^{th} D3-brane is at $x_3 = -m_1$, corresponding to $\sigma_{N_c}^{N_c} = m_1$. The configuration is given by:

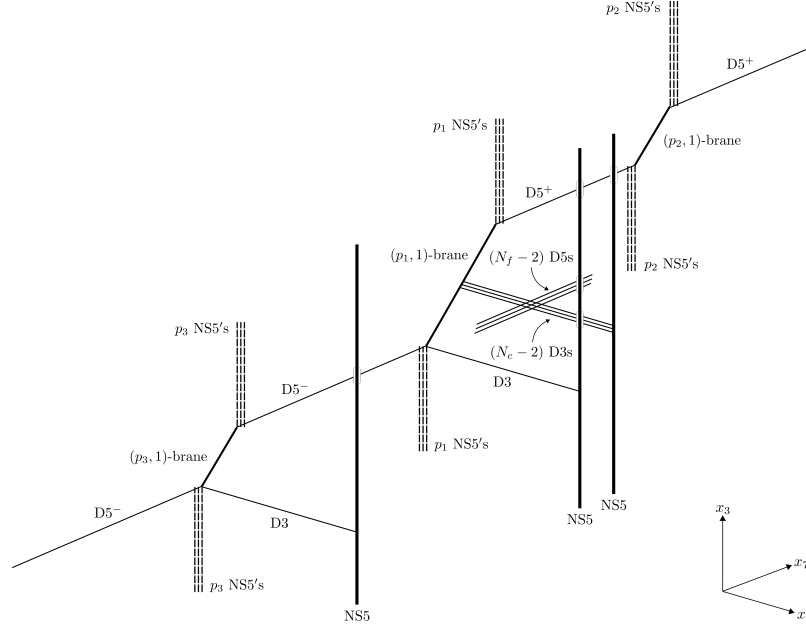

Matter Content:

One flavour of massive matter, with mass $m_1 + m_2$, in fundamental of $U(1)_{N_c}$.

One flavour of massive matter, with mass $2m_1$, in fundamental of $U(1)_{N_c}$.

$N_f - 2$ flavours of massive matter, with mass m_1 , in fundamental of $U(1)_{N_c}$.

$N_f - 2$ flavours of massive antimatter, with mass $-m_1$, in antifundamental of $U(1)_{N_c}$.

One flavour of massive antimatter, with mass $m_2 - m_1 < 0$, in antifundamental of $U(1)_{N_c}$.

One flavour of massless antimatter in antifundamental of $U(1)_{N_c}$.

- One flavour of massive matter, with mass $2m_2$, in fundamental of $U(1)_{N_c-1}$.
- One flavour of massive matter, with mass $m_1 + m_2$, in fundamental of $U(1)_{N_c-1}$.
- $N_f - 2$ flavours of massive matter, with mass m_2 , in fundamental of $U(1)_{N_c-1}$.
- $N_f - 2$ flavours of massive antimatter, with mass $-m_2$, in antifundamental of $U(1)_{N_c-1}$.
- One flavour of massive antimatter, with mass $m_1 - m_2 > 0$, in antifundamental of $U(1)_{N_c-1}$.
- One flavour of massless antimatter in antifundamental of $U(1)_{N_c-1}$.
- One flavour of massive matter, with mass m_1 , in the fundamental of $U(N_c - 2)$.
- One flavour of massive matter, with mass m_2 , in the fundamental of $U(N_c - 2)$.
- $N_f - 2$ flavours of massless matter in the fundamental of $U(N_c - 2)$.
- $N_f - 2$ flavours of massless antimatter in the antifundamental of $U(N_c - 2)$.
- One flavour of massive antimatter, with mass m_2 , in the antifundamental of $U(N_c - 2)$.
- One flavour of massive antimatter, with mass m_1 , in the antifundamental of $U(N_c - 2)$.

Aharony and Giveon-Kutasov Duality:

The high energy theory contains the massive and massless matter and antimatter listed above, transforming in the gauge group:

$$U(N_c - 2)_k \times U(1)_{N_c-1,k} \times U(1)_{N_c,k} \tag{8.56}$$

The low energy theory contains the massless matter and antimatter listed above, transforming in the gauge group:

$$U(N_c - 2)_{k+2} \times U(1)_{N_c-1,k+\frac{3}{2}} \times U(1)_{N_c,k+\frac{1}{2}} \tag{8.57}$$

$k = -2$) The $U(N_c - 2)$ group exhibits a flow from Giveon-Kutasov to Aharony duality. The two $U(1)$ groups exhibit no flow between dualities, and Giveon-Kutasov duality at low energies.

$k = -\frac{3}{2}$) The $U(1)_{N_c-1}$ gauge group exhibits a flow from Giveon-Kutasov to Aharony duality. The other gauge groups exhibit no flow between dualities, and Giveon-Kutasov duality at low energies.

$k = -\frac{1}{2}$) The $U(1)_{N_c}$ gauge group exhibits a flow from Giveon-Kutasov to Aharony duality. The other gauge groups exhibit no flow between dualities, and Giveon-Kutasov duality at low energies.

$k = 0$) All gauge groups exhibit a flow from Aharony duality to Giveon-Kutasov.

$k \neq -2, -\frac{3}{2}, -\frac{1}{2}, 0$) All gauge groups exhibit no flow between dualities, and Giveon-Kutasov duality at low energies.

8.3.8 One D3-brane Displaced Upwards to $x_3 = m_2$ and One D3-brane Displaced Downwards to $x_3 = -m_2$

The D5-branes labelled by the flavour indices $1, \dots, N_f - 2$ are at $x_3 = 0$, corresponding to $m_1^1, m_2^2, \dots, m_{N_f-2}^{N_f-2} = \tilde{m}_1^1, \tilde{m}_2^2, \dots, \tilde{m}_{N_f-2}^{N_f-2} = 0$. The $(N_f - 1)^{\text{th}}$ D5-brane is displaced and split into a $D5^+$ at $x_3 = m_2$ and a $D5^-$ at $x_3 = -m_2$, corresponding to $m_{N_f-1}^{N_f-1} = \tilde{m}_{N_f-1}^{N_f-1} = m_2$. The N_f^{th} D5-brane is displaced and split into a $D5^+$ at $x_3 = m_1$ and a $D5^-$ at $x_3 = -m_1$, corresponding to $m_{N_f}^{N_f} = \tilde{m}_{N_f}^{N_f} = m_1$, where $m_1 > m_2$. The D3-branes labelled by the colour indices $1, \dots, N_c - 2$ are at $x_3 = 0$, corresponding to $\sigma_1^1, \sigma_2^2, \dots, \sigma_{N_c-2}^{N_c-2} = 0$. The $(N_c - 1)^{\text{th}}$ D3-brane is at $x_3 = -m_2$, corresponding to $\sigma_{N_c-1}^{N_c-1} = m_2$. Lastly, the N_c^{th} D3-brane is at $x_3 = m_2$, corresponding to $\sigma_{N_c}^{N_c} = -m_2$. The configuration is given by:

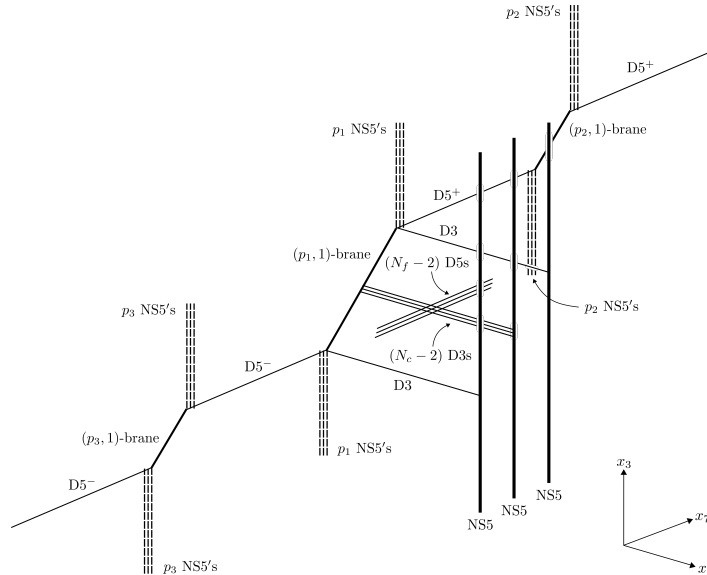

Matter Content:

One flavour of massive matter, with mass $m_1 - m_2 > 0$, in fundamental of $U(1)_{N_c}$.

One flavour of massless matter in fundamental of $U(1)_{N_c}$.

$N_f - 2$ flavours of massive matter, with mass $-m_2$, in fundamental of $U(1)_{N_c}$.

$N_f - 2$ flavours of massive antimatter, with mass m_2 , in antifundamental of $U(1)_{N_c}$.

One flavour of massive antimatter, with mass $2m_2$, in antifundamental of $U(1)_{N_c}$.

One flavour of massive antimatter, with mass $m_1 + m_2$, in antifundamental of $U(1)_{N_c}$.

One flavour of massive matter, with mass $m_1 + m_2$, in fundamental of $U(1)_{N_c-1}$.

One flavour of massive matter, with mass $2m_2$, in fundamental of $U(1)_{N_c-1}$.

$N_f - 2$ flavours of massive matter, with mass m_2 , in fundamental of $U(1)_{N_c-1}$.

$N_f - 2$ flavours of massive antimatter, with mass $-m_2$, in antifundamental of $U(1)_{N_c-1}$.

One flavour of massive antimatter, with mass $m_1 - m_2 > 0$, in antifundamental of $U(1)_{N_c-1}$.

One flavour of massless antimatter in antifundamental of $U(1)_{N_c-1}$.

One flavour of massive matter, with mass m_1 , in the fundamental of $U(N_c - 2)$.

One flavour of massive matter, with mass m_2 , in the fundamental of $U(N_c - 2)$.

$N_f - 2$ flavours of massless matter in the fundamental of $U(N_c - 2)$.

$N_f - 2$ flavours of massless antimatter in the antifundamental of $U(N_c - 2)$.

One flavour of massive antimatter, with mass m_2 , in the antifundamental of $U(N_c - 2)$.

One flavour of massive antimatter, with mass m_1 , in the antifundamental of $U(N_c - 2)$.

Aharony and Giveon-Kutasov Duality:

The high energy theory contains the massive and massless matter and antimatter listed above, transforming in the gauge group:

$$U(N_c - 2)_k \times U(1)_{N_c-1,k} \times U(1)_{N_c,k} \tag{8.58}$$

The low energy theory contains the massless matter and antimatter listed above, transforming in the gauge group:

$$U(N_c - 2)_{k+2} \times U(1)_{N_c-1, k+\frac{3}{2}} \times U(1)_{N_c, k+\frac{3}{2}} \quad (8.59)$$

$k = -2$) The $U(N_c - 2)$ group exhibits a flow from Giveon-Kutasov to Aharony duality. The two $U(1)$ groups exhibit no flow between dualities, and Giveon-Kutasov duality at low energies.

$k = -\frac{3}{2}$) The $U(1)_{N_c-1}$ and $U(1)_{N_c}$ gauge groups exhibit a flow from Giveon-Kutasov to Aharony duality. The $U(N_c - 2)$ gauge group exhibits no flow between dualities, and Giveon-Kutasov duality at low energies.

$k = 0$) All gauge groups exhibit a flow from Aharony duality to Giveon-Kutasov.

$k \neq -2, -\frac{3}{2}, 0$) All gauge groups exhibit no flow between dualities, and Giveon-Kutasov duality at low energies.

8.3.9 One D3-brane Displaced Upwards to $x_3 = m_1$ and one D3-brane Displaced Downwards to $x_3 = -m_1$

The D5-branes labelled by the flavour indices $1, \dots, N_f - 2$ are at $x_3 = 0$, corresponding to $m_1^1, m_2^2, \dots, m_{N_f-2}^{N_f-2} = \tilde{m}_1^1, \tilde{m}_2^2, \dots, \tilde{m}_{N_f-2}^{N_f-2} = 0$. The $(N_f - 1)^{\text{th}}$ D5-brane is displaced and split into a $D5^+$ at $x_3 = m_2$ and a $D5^-$ at $x_3 = -m_2$, corresponding to $m_{N_f-1}^{N_f-1} = \tilde{m}_{N_f-1}^{N_f-1} = m_2$. The N_f^{th} D5-brane is displaced and split into a $D5^+$ at $x_3 = m_1$ and a $D5^-$ at $x_3 = -m_1$, corresponding to $m_{N_f}^{N_f} = \tilde{m}_{N_f}^{N_f} = m_1$, where $m_1 > m_2$. The D3-branes labelled by the colour indices $1, \dots, N_c - 2$ are at $x_3 = 0$, corresponding to $\sigma_1^1, \sigma_2^2, \dots, \sigma_{N_c-2}^{N_c-2} = 0$. The $(N_c - 1)^{\text{th}}$ D3-brane is at $x_3 = -m_1$, corresponding to $\sigma_{N_c-1}^{N_c-1} = m_1$. Lastly, the N_c^{th} D3-brane is at $x_3 = m_1$, corresponding to $\sigma_{N_c}^{N_c} = -m_1$. The configuration is given by:

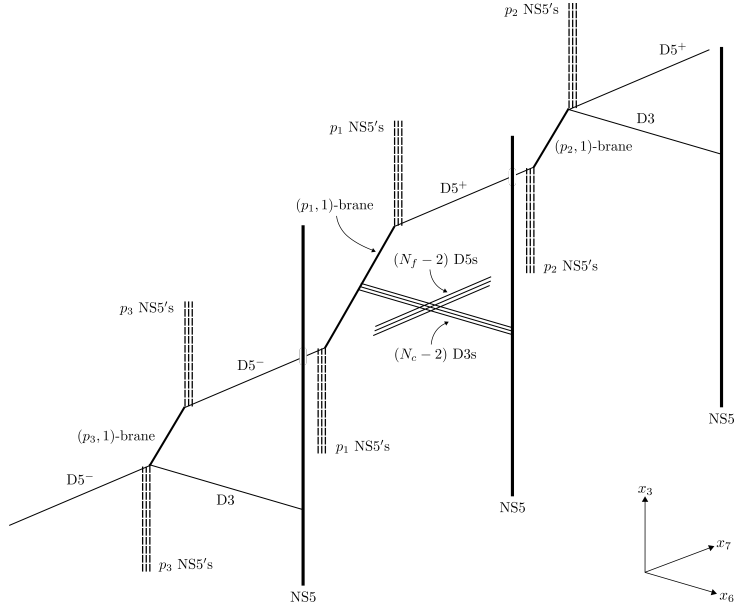

Matter Content:

One flavour of massive matter, with mass $m_2 - m_1 < 0$, in fundamental of $U(1)_{N_c}$.

One flavour of massless matter in fundamental of $U(1)_{N_c}$.

$N_f - 2$ flavours of massive matter, with mass $-m_1$, in fundamental of $U(1)_{N_c}$.

$N_f - 2$ flavours of massive antimatter, with mass m_1 , in antifundamental of $U(1)_{N_c}$.

One flavour of massive antimatter, with mass $2m_1$, in antifundamental of $U(1)_{N_c}$.

One flavour of massive antimatter, with mass $m_1 + m_2$, in antifundamental of $U(1)_{N_c}$.

One flavour of massive matter, with mass $m_1 + m_2$, in fundamental of $U(1)_{N_c-1}$.

One flavour of massive matter, with mass $2m_1$, in fundamental of $U(1)_{N_c-1}$.

$N_f - 2$ flavours of massive matter, with mass m_1 , in fundamental of $U(1)_{N_c-1}$.

$N_f - 2$ flavours of massive antimatter, with mass $-m_1$, in antifundamental of $U(1)_{N_c-1}$.

One flavour of massive antimatter, with mass $m_2 - m_1 > 0$, in antifundamental of $U(1)_{N_c-1}$.

One flavour of massless antimatter in antifundamental of $U(1)_{N_c-1}$.

One flavour of massive matter, with mass m_1 , in the fundamental of $U(N_c - 2)$.

One flavour of massive matter, with mass m_2 , in the fundamental of $U(N_c - 2)$.

$N_f - 2$ flavours of massless matter in the fundamental of $U(N_c - 2)$.

$N_f - 2$ flavours of massless antimatter in the antifundamental of $U(N_c - 2)$.

One flavour of massive antimatter, with mass m_2 , in the antifundamental of $U(N_c - 2)$.

One flavour of massive antimatter, with mass m_1 , in the antifundamental of $U(N_c - 2)$.

Aharony and Giveon-Kutasov Duality:

The high energy theory contains the massive and massless matter and antimatter listed above, transforming in the gauge group:

$$U(N_c - 2)_k \times U(1)_{N_c - 1, k} \times U(1)_{N_c, k} \tag{8.60}$$

The low energy theory contains the massless matter and antimatter listed above, transforming in the gauge group:

$$U(N_c - 2)_{k+2} \times U(1)_{N_c - 1, k + \frac{1}{2}} \times U(1)_{N_c, k + \frac{1}{2}} \tag{8.61}$$

$k = -2$) The $U(N_c - 2)$ group exhibits a flow from Giveon-Kutasov to Aharony duality. The two $U(1)$ groups exhibit no flow between dualities, and Giveon-Kutasov duality at low energies.

$k = -\frac{1}{2}$) The $U(1)_{N_c - 1}$ and $U(1)_{N_c}$ gauge groups exhibit a flow from Giveon-Kutasov to Aharony duality. The $U(N_c - 2)$ gauge group exhibits no flow between dualities, and Giveon-Kutasov duality at low energies.

$k = 0$) All gauge groups exhibit a flow from Aharony duality to Giveon-Kutasov.

$k \neq -2, -\frac{1}{2}, 0$) All gauge groups exhibit no flow between dualities, and Giveon-Kutasov duality at low energies.

8.3.10 One D3-brane Displaced Upwards to $x_3 = m_1$ and One D3-brane Displaced Downwards to $x_3 = -m_2$

The D5-branes labelled by the flavour indices $1, \dots, N_f - 2$ are at $x_3 = 0$, corresponding to $m_1^1, m_2^2, \dots, m_{N_f-2}^{N_f-2} = \tilde{m}_1^1, \tilde{m}_2^2, \dots, \tilde{m}_{N_f-2}^{N_f-2} = 0$. The $(N_f - 1)^{\text{th}}$ D5-brane is displaced and split into a $D5^+$ at $x_3 = m_2$ and a $D5^-$ at $x_3 = -m_2$, corresponding to $m_{N_f-1}^{N_f-1} = \tilde{m}_{N_f-1}^{N_f-1} = m_2$. The N_f^{th} D5-brane is displaced and split into a $D5^+$ at $x_3 = m_1$ and a $D5^-$ at $x_3 = -m_1$, corresponding to $m_{N_f}^{N_f} = \tilde{m}_{N_f}^{N_f} = m_1$, where $m_1 > m_2$. The D3-branes labelled by the colour indices $1, \dots, N_c - 2$ are at $x_3 = 0$, corresponding to $\sigma_1^1, \sigma_2^2, \dots, \sigma_{N_c-2}^{N_c-2} = 0$. The $(N_c - 1)^{\text{th}}$ D3-brane is at $x_3 = -m_2$, corresponding to $\sigma_{N_c-1}^{N_c-1} = m_2$. Lastly, the N_c^{th} D3-brane is at $x_3 = m_1$, corresponding to $\sigma_{N_c}^{N_c} = -m_1$. The configuration is given by:

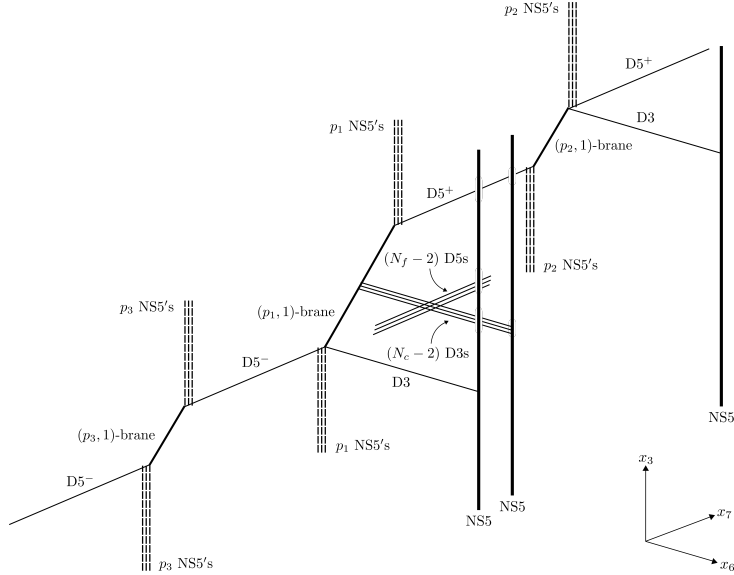

Matter Content:

One flavour of massive matter, with mass $m_2 - m_1 < 0$, in fundamental of $U(1)_{N_c}$.

One flavour of massless matter in fundamental of $U(1)_{N_c}$.

$N_f - 2$ flavours of massive matter, with mass $-m_1$, in fundamental of $U(1)_{N_c}$.

$N_f - 2$ flavours of massive antimatter, with mass m_1 , in antifundamental of $U(1)_{N_c}$.

One flavour of massive antimatter, with mass $2m_1$, in antifundamental of $U(1)_{N_c}$.

One flavour of massive antimatter, with mass $m_1 + m_2$, in antifundamental of $U(1)_{N_c}$.

One flavour of massive matter, with mass $m_1 + m_2$, in fundamental of $U(1)_{N_c-1}$.

One flavour of massive matter, with mass $2m_2$, in fundamental of $U(1)_{N_c-1}$.

$N_f - 2$ flavours of massive matter, with mass m_2 , in fundamental of $U(1)_{N_c-1}$.

$N_f - 2$ flavours of massive antimatter, with mass $-m_2$, in antifundamental of $U(1)_{N_c-1}$.

One flavour of massive antimatter, with mass $m_1 - m_2 > 0$, in antifundamental of $U(1)_{N_c-1}$.

One flavour of massless antimatter in antifundamental of $U(1)_{N_c-1}$.

One flavour of massive matter, with mass m_1 , in the fundamental of $U(N_c - 2)$.

One flavour of massive matter, with mass m_2 , in the fundamental of $U(N_c - 2)$.

$N_f - 2$ flavours of massless matter in the fundamental of $U(N_c - 2)$.

$N_f - 2$ flavours of massless antimatter in the antifundamental of $U(N_c - 2)$.

One flavour of massive antimatter, with mass m_2 , in the antifundamental of $U(N_c - 2)$.

One flavour of massive antimatter, with mass m_1 , in the antifundamental of $U(N_c - 2)$.

Aharony and Giveon-Kutasov Duality:

The high energy theory contains the massive and massless matter and antimatter listed above, transforming in the gauge group:

$$U(N_c - 2)_k \times U(1)_{N_c-1,k} \times U(1)_{N_c,k} \quad (8.62)$$

The low energy theory contains the massless matter and antimatter listed above, transforming in the gauge group:

$$U(N_c - 2)_{k+2} \times U(1)_{N_c-1,k+\frac{3}{2}} \times U(1)_{N_c,k+\frac{1}{2}} \quad (8.63)$$

$k = -2$) The $U(N_c - 2)$ group exhibits a flow from Giveon-Kutasov to Aharony duality. The two $U(1)$ groups exhibit no flow between dualities, and Giveon-Kutasov duality at low energies.

$k = -\frac{1}{2}$) The $U(1)_{N_c}$ gauge group exhibits a flow from Giveon-Kutasov to Aharony duality. The other gauge groups exhibit no flow between dualities, and Giveon-Kutasov duality at low energies.

$k = -\frac{3}{2}$) The $U(1)_{N_c-1}$ gauge group exhibits a flow from Giveon-Kutasov to Aharony duality. The other gauge groups exhibit no flow between dualities, and Giveon-Kutasov duality at low energies.

$k = 0$) All gauge groups exhibit a flow from Aharony duality to Giveon-Kutasov.

$k \neq -2, -\frac{3}{2}, -\frac{1}{2}, 0$) All gauge groups exhibit no flow between dualities, and Giveon-Kutasov duality at low energies.

8.3.11 One D3-brane Displaced Upwards to $x_3 = m_2$ and One D3-brane Displaced Downwards to $x_3 = -m_1$

The D5-branes labelled by the flavour indices $1, \dots, N_f - 2$ are at $x_3 = 0$, corresponding to $m_1^1, m_2^2, \dots, m_{N_f-2}^{N_f-2} = \tilde{m}_1^1, \tilde{m}_2^2, \dots, \tilde{m}_{N_f-2}^{N_f-2} = 0$. The $(N_f - 1)^{\text{th}}$ D5-brane is displaced and split into a $D5^+$ at $x_3 = m_2$ and a $D5^-$ at $x_3 = -m_2$, corresponding to $m_{N_f-1}^{N_f-1} = \tilde{m}_{N_f-1}^{N_f-1} = m_2$. The N_f^{th} D5-brane is displaced and split into a $D5^+$ at $x_3 = m_1$ and a $D5^-$ at $x_3 = -m_1$, corresponding to $m_{N_f}^{N_f} = \tilde{m}_{N_f}^{N_f} = m_1$, where $m_1 > m_2$. The D3-branes labelled by the colour indices $1, \dots, N_c - 2$ are at $x_3 = 0$, corresponding to $\sigma_1^1, \sigma_2^2, \dots, \sigma_{N_c-2}^{N_c-2} = 0$. The $(N_c - 1)^{\text{th}}$ D3-brane is at $x_3 = -m_1$, corresponding to $\sigma_{N_c-1}^{N_c-1} = m_1$. Lastly, the N_c^{th} D3-brane is at $x_3 = m_2$, corresponding to $\sigma_{N_c}^{N_c} = -m_2$. The configuration is given by:

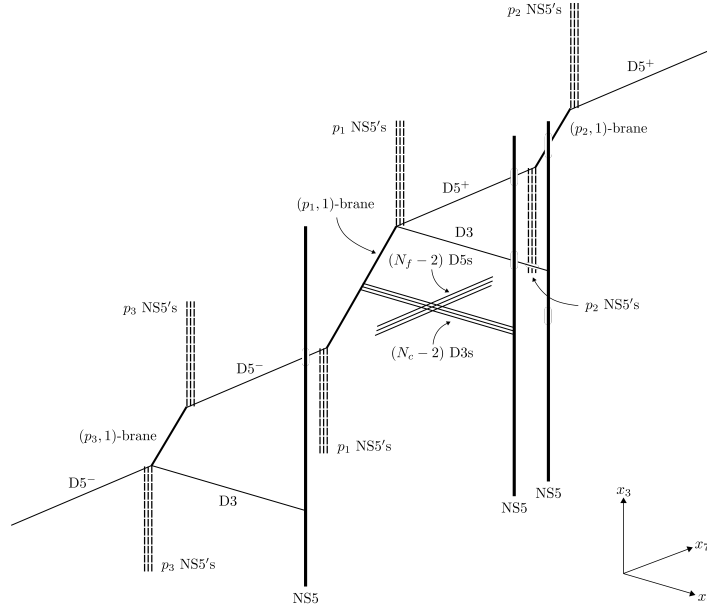

Matter Content:

One flavour of massive matter, with mass $m_1 - m_2 > 0$, in fundamental of $U(1)_{N_c}$.

One flavour of massless matter in fundamental of $U(1)_{N_c}$.

$N_f - 2$ flavours of massive matter, with mass $-m_2$, in fundamental of $U(1)_{N_c}$.

$N_f - 2$ flavours of massive antimatter, with mass m_2 , in antifundamental of $U(1)_{N_c}$.

One flavour of massive antimatter, with mass $2m_2$, in antifundamental of $U(1)_{N_c}$.

One flavour of massive antimatter, with mass $m_1 + m_2$, in antifundamental of $U(1)_{N_c}$.

One flavour of massive matter, with mass $m_1 + m_2$, in fundamental of $U(1)_{N_c-1}$.

One flavour of massive matter, with mass $2m_1$, in fundamental of $U(1)_{N_c-1}$.

$N_f - 2$ flavours of massive matter, with mass m_1 , in fundamental of $U(1)_{N_c-1}$.

$N_f - 2$ flavours of massive antimatter, with mass $-m_1$, in antifundamental of $U(1)_{N_c-1}$.

One flavour of massive antimatter, with mass $m_2 - m_1 < 0$, in antifundamental of $U(1)_{N_c-1}$.

One flavour of massless antimatter in antifundamental of $U(1)_{N_c-1}$.

One flavour of massive matter, with mass m_1 , in the fundamental of $U(N_c - 2)$.

One flavour of massive matter, with mass m_2 , in the fundamental of $U(N_c - 2)$.

$N_f - 2$ flavours of massless matter in the fundamental of $U(N_c - 2)$.

$N_f - 2$ flavours of massless antimatter in the antifundamental of $U(N_c - 2)$.

One flavour of massive antimatter, with mass m_2 , in the antifundamental of $U(N_c - 2)$.

One flavour of massive antimatter, with mass m_1 , in the antifundamental of $U(N_c - 2)$.

Aharony and Giveon-Kutasov Duality:

The high energy theory contains the massive and massless matter and antimatter listed above, transforming in the gauge group:

$$U(N_c - 2)_k \times U(1)_{N_c-1,k} \times U(1)_{N_c,k} \tag{8.64}$$

The low energy theory contains the massless matter and antimatter listed above, transforming in the gauge group:

$$U(N_c - 2)_{k+2} \times U(1)_{N_c-1, k+\frac{1}{2}} \times U(1)_{N_c, k+\frac{3}{2}} \quad (8.65)$$

$k = -2$) The $U(N_c - 2)$ group exhibits a flow from Giveon-Kutasov to Aharony duality. The two $U(1)$ groups exhibit no flow between dualities, and Giveon-Kutasov duality at low energies.

$k = -\frac{1}{2}$) The $U(1)_{N_c-1}$ gauge group exhibits a flow from Giveon-Kutasov to Aharony duality. The other gauge groups exhibit no flow between dualities, and Giveon-Kutasov duality at low energies.

$k = -\frac{3}{2}$) The $U(1)_{N_c}$ gauge group exhibits a flow from Giveon-Kutasov to Aharony duality. The other gauge groups exhibit no flow between dualities, and Giveon-Kutasov duality at low energies.

$k = 0$) All gauge groups exhibit a flow from Aharony duality to Giveon-Kutasov.

$k \neq -2, -\frac{3}{2}, -\frac{1}{2}, 0$) All gauge groups exhibit no flow between dualities, and Giveon-Kutasov duality at low energies.

9 Theories with Adjoint Matter

In section 4.7 it was mentioned that adjoint matter can be included in the 3d $N = 2$ theory. In sections 7.4.1 and 7.5.1 the Aharony and Giveon-Kutasov dualities (respectively) of 3d $N = 2$ theories was discussed. In this section, the consequences of including adjoint matter as well as making some of the fundamental and antifundamental matter massive is discussed, with a focus on the resulting IR dualities.

Notation: Throughout this section all i indices (including those with dashes) are flavour indices. All j indices (including those with dashes) are colour indices. All j_t , k_t , l_t , m_t and n_t indices (including those with dashes) are colour indices associated with gauge groups $U(r_t)$.

An ‘electric’ $U(N_c)_k$ theory ¹¹ with N_f flavours, has a semiclassical potential given by equation 4.49:

$$\begin{aligned}
V_{sc} = & \frac{e^2}{32\pi^2} \text{Tr} \left(\left(4\pi \bar{\phi}_{i,j''} \phi^{i,j'} - 4\pi \bar{\tilde{\phi}}_{i,j''} \tilde{\phi}^{i,j'} - \zeta_{\text{eff}} \delta_{j''}^{j'} - k_{\text{eff}} \sigma_{j''}^{j'} \right) \right. \\
& \times \left. \left(4\pi \bar{\phi}_{i,j'} \phi^{i,j} - 4\pi \bar{\tilde{\phi}}_{i,j'} \tilde{\phi}^{i,j} - \zeta_{\text{eff}} \delta_{j'}^j - k_{\text{eff}} \sigma_{j'}^j \right) \right) \\
& + \bar{\phi}_{i'',j''} \left(\delta_{j'}^{j''} m_{i'}^{i''} + \sigma_{j'}^{j''} \delta_{i'}^{i''} \right) \left(\delta_j^{j'} m_i^{i'} + \sigma_j^{j'} \delta_i^{i'} \right) \phi^{i,j} \\
& + \bar{\tilde{\phi}}_{i'',j''} \left(\delta_{j'}^{j''} \tilde{m}_{i'}^{i''} - \sigma_{j'}^{j''} \delta_{i'}^{i''} \right) \left(\delta_j^{j'} \tilde{m}_i^{i'} - \sigma_j^{j'} \delta_i^{i'} \right) \tilde{\phi}^{i,j}
\end{aligned} \tag{9.1}$$

where $i, i', i'' = 1, \dots, N_f$ are flavour indices, whilst $j, j', j'' = 1, \dots, N_c$ are colour indices. Note that the charges q_i are set to one. The results that will be obtained will minimise this potential.

Theories with adjoint matter have a superpotential which, when minimized, breaks the $U(N_c)$ gauge group into n subgroups:

$$U(N_c) \rightarrow U(r_1) \times U(r_2) \times \dots \times U(r_n) \tag{9.2}$$

where:

$$\sum_{t=1}^n r_t = N_c \tag{9.3}$$

and where $n \leq N_c$.

¹¹Recall that the subscript k of the gauge group is the Chern-Simons level associated with it.

The result of this is that there is a separate semiclassical potential of the form of equation 9.1 for each of the n gauge groups. In general the potentials are given by:

$$\begin{aligned}
V_{sc,t} = & \frac{e^2}{32\pi^2} \text{Tr} \left(\left(4\pi \bar{\phi}_{i,j_t} \phi^{i,j_t} - 4\pi \bar{\tilde{\phi}}_{i,j_t} \tilde{\phi}^{i,j_t} - \zeta_{\text{eff}} \delta_{j_t}^{j_t'} - k_{\text{eff}} \sigma_{j_t}^{j_t'} \right) \right. \\
& \times \left. \left(4\pi \bar{\phi}_{i,j_t} \phi^{i,j_t} - 4\pi \bar{\tilde{\phi}}_{i,j_t} \tilde{\phi}^{i,j_t} - \zeta_{\text{eff}} \delta_{j_t}^{j_t'} - k_{\text{eff}} \sigma_{j_t}^{j_t'} \right) \right) \\
& + \bar{\phi}_{i'',j_t} \left(\delta_{j_t}^{j_t''} m_{i'}^{i''} + \sigma_{j_t}^{j_t''} \delta_{i'}^{i''} \right) \left(\delta_{j_t}^{j_t'} m_i^{i'} + \sigma_{j_t}^{j_t'} \delta_i^{i'} \right) \phi^{i,j_t} \\
& + \bar{\tilde{\phi}}_{i'',j_t} \left(\delta_{j_t}^{j_t''} \tilde{m}_{i'}^{i''} - \sigma_{j_t}^{j_t''} \delta_{i'}^{i''} \right) \left(\delta_{j_t}^{j_t'} \tilde{m}_i^{i'} - \sigma_{j_t}^{j_t'} \delta_i^{i'} \right) \tilde{\phi}^{i,j_t}
\end{aligned} \tag{9.4}$$

This requires the use of the index t to clarify which gauge group the potential refers to. So, for example, $V_{sc,2}$ would refer to the semiclassical potential of the group $U(r_2)$. Note that the colour indices j, j', j'' are now labelled by t . This is because the range of the numbers that the j_t, j_t', j_t'' indices run over depends on the gauge group $U(r_t)$ that the particular potential is associated with. In general $j_t, j_t', j_t'' = 1, \dots, r_t$.

Once the gauge group is broken with the inclusion of adjoint matter, the flows between dualities caused by the inclusion of massive fundamental and antifundamental matter are investigated.

9.1 One Massive Flavour

Consider the case where the N_f^{th} flavour of matter $\phi^{N_f,j}$ and the N_f^{th} flavour of antimatter $\tilde{\phi}^{N_f,j}$ have the same mass m_a . The subscript a is simply to identify this as a particular value of the mass, and to avoid confusion with the mass parameters $m_i^{i'}$ or $\tilde{m}_i^{i'}$. This means that:

$$\begin{aligned}
& \bar{\phi}_{N_f,j_t} \left(\delta_{j_t}^{j_t''} m_{N_f}^{N_f} + \sigma_{j_t}^{j_t''} \delta_{N_f}^{N_f} \right) \left(\delta_{j_t}^{j_t'} m_{N_f}^{N_f} + \sigma_{j_t}^{j_t'} \delta_{N_f}^{N_f} \right) \phi^{N_f,j_t} \\
= & \bar{\phi}_{N_f,j_t} \left(\delta_{j_t}^{j_t''} m_a \right) \left(\delta_{j_t}^{j_t'} m_a \right) \phi^{N_f,j_t}
\end{aligned} \tag{9.5}$$

for the matter, and:

$$\begin{aligned}
& \bar{\tilde{\phi}}_{N_f,j_t} \left(\delta_{j_t}^{j_t''} \tilde{m}_{N_f}^{N_f} - \sigma_{j_t}^{j_t''} \delta_{N_f}^{N_f} \right) \left(\delta_{j_t}^{j_t'} \tilde{m}_{N_f}^{N_f} - \sigma_{j_t}^{j_t'} \delta_{N_f}^{N_f} \right) \tilde{\phi}^{N_f,j_t} \\
= & \bar{\tilde{\phi}}_{N_f,j_t} \left(\delta_{j_t}^{j_t''} m_a \right) \left(\delta_{j_t}^{j_t'} m_a \right) \tilde{\phi}^{N_f,j_t}
\end{aligned} \tag{9.6}$$

for the antimatter.

9.1.1 All σ Equal Zero

The N_f^{th} flavour of matter is massive, and the indices $\bar{i}, \bar{i}', \bar{i}'' = 1, \dots, N_f - 1$ are used to denote the massless flavours. The semiclassical scalar potentials, labelled by $t = 1, \dots, n$, contain the mass terms:

$$\begin{aligned}
V_{sc,t} \ni & + \bar{\phi}_{N_f, j_t''} \left(\delta_{j_t}^{j_t''} m_{N_f}^{N_f} + \sigma_{j_t}^{j_t''} \delta_{N_f}^{N_f} \right) \left(\delta_{j_t}^{j_t'} m_{N_f}^{N_f} + \sigma_{j_t}^{j_t'} \delta_{N_f}^{N_f} \right) \phi^{N_f, j_t} \\
& + \bar{\phi}_{N_f, j_t''} \left(\delta_{j_t}^{j_t''} \tilde{m}_{N_f}^{N_f} - \sigma_{j_t}^{j_t''} \delta_{N_f}^{N_f} \right) \left(\delta_{j_t}^{j_t'} \tilde{m}_{N_f}^{N_f} - \sigma_{j_t}^{j_t'} \delta_{N_f}^{N_f} \right) \tilde{\phi}^{N_f, j_t} \\
& + \bar{\phi}_{\bar{i}'', j_t''} \left(\delta_{j_t}^{j_t''} m_{\bar{i}''}^{\bar{i}''} + \sigma_{j_t}^{j_t''} \delta_{\bar{i}''}^{\bar{i}''} \right) \left(\delta_{j_t}^{j_t'} m_{\bar{i}'}^{\bar{i}'} + \sigma_{j_t}^{j_t'} \delta_{\bar{i}'}^{\bar{i}'} \right) \phi^{\bar{i}, j_t} \\
& + \bar{\phi}_{\bar{i}'', j_t''} \left(\delta_{j_t}^{j_t''} \tilde{m}_{\bar{i}''}^{\bar{i}''} - \sigma_{j_t}^{j_t''} \delta_{\bar{i}''}^{\bar{i}''} \right) \left(\delta_{j_t}^{j_t'} \tilde{m}_{\bar{i}'}^{\bar{i}'} - \sigma_{j_t}^{j_t'} \delta_{\bar{i}'}^{\bar{i}'} \right) \tilde{\phi}^{\bar{i}, j_t}
\end{aligned} \tag{9.7}$$

where $j_t, j_t', j_t'' = 1, \dots, r_t$. In order for the N_f^{th} flavours of matter and antimatter to have a mass, $m_{N_f}^{N_f} + \sigma_{j_t}^{j_t'}$ and $\tilde{m}_{N_f}^{N_f} + \sigma_{j_t}^{j_t''}$ must be non-zero. It follows that the only way that the potentials can be set to zero, and have the N_f^{th} flavour as massive, is if $\phi^{N_f, j_t} = \tilde{\phi}^{N_f, j_t} = 0$ for all t . This section considers the case where $\sigma_{j_t}^{j_t'} = \sigma_{j_t}^{j_t''} = 0$ for all values of t . For the massive flavour, with mass m_a , this sets $m_{N_f}^{N_f} = \tilde{m}_{N_f}^{N_f} = m_a$ for all t . For the massless flavours, $\sigma_{j_t}^{j_t'} = \sigma_{j_t}^{j_t''} = 0$ means $m_{\bar{i}''}^{\bar{i}''} = m_{\bar{i}'}^{\bar{i}'} = \tilde{m}_{\bar{i}''}^{\bar{i}''} = \tilde{m}_{\bar{i}'}^{\bar{i}'} = 0$, for all t .

Consider the derivative of the superpotential with respect to Φ in equation 4.64:

$$W'(x) = \sum_{s=0}^n c_s \Phi^{n-s} = c_0 \prod_{t=1}^n (\Phi - a_t) \tag{9.8}$$

To avoid confusion with the flavour index and the colour index, the indices in the above equation has been changed from i to s and from j to t . For c_s ($s = 0, \dots, n$) all non-zero, the gauge group of the high energy theory is given by a product of n gauge groups:

$$U(r_1)_k \times U(r_2)_k \times \dots \times U(r_n)_k \tag{9.9}$$

Since the N_f^{th} flavour of matter and antimatter both have mass m_a , integrating them out leads to two contributions to CS-level of $+1/2$. The low energy theory becomes:

$$U(r_1)_{k+1} \times U(r_2)_{k+1} \times \dots \times U(r_n)_{k+1} \tag{9.10}$$

with $N_f - 1$ flavours of massless matter. As a side note, consider the case when all c_s with the exception of c_0 equal zero. Then the superpotential in equation 4.63 becomes:

$$W(x) = \frac{c_0}{n+1} \Phi^{n+1} \quad (9.11)$$

$$\Rightarrow W'(x) = c_0 \Phi^n \quad (9.12)$$

In this case the low energy theory is:

$$U(N_c)_{k+1} \quad (9.13)$$

with $N_f - 1$ massless flavours.

Aharony and Giveon-Kutasov Duality:

$k = -1$) The high energy theory is:

$$U(r_1)_{-1} \times U(r_2)_{-1} \times \dots \times U(r_n)_{-1} \quad (9.14)$$

with $N_f - 1$ flavours of massless matter and one flavour of massive matter. The low energy theory is

$$U(r_1)_0 \times U(r_2)_0 \times \dots \times U(r_n)_0 \quad (9.15)$$

with $N_f - 1$ flavours of massless matter. There is a flow from Giveon-Kutasov to Aharony duality.

$k = 0$) The high energy theory is:

$$U(r_1)_0 \times U(r_2)_0 \times \dots \times U(r_n)_0 \quad (9.16)$$

with $N_f - 1$ flavours of massless matter and one flavour of massive matter. The low energy theory is

$$U(r_1)_1 \times U(r_2)_1 \times \dots \times U(r_n)_1 \quad (9.17)$$

with $N_f - 1$ flavours of massless matter. There is a flow from Aharony to Giveon-Kutasov duality.

$k \neq -1, 0$) There is no flow between dualities. The low energy theory exhibits Giveon-Kutasov duality.

9.1.2 Some σ Components are Positive

The N_f^{th} flavour of matter is massive, and the indices $\bar{i}, \bar{i}', \bar{i}'' = 1, \dots, N_f - 1$ are used to denote the massless flavours. Consider the case where $\sigma_{k_t'}^{k_t''} = \sigma_{k_t}^{k_t'} = 0$ for $k_t, k_t', k_t'' = 1, \dots, r_t - A$ (corresponding to a $U(r_t - A)$ gauge group), and where $\sigma_{l_t'}^{l_t''} = \sigma_{l_t}^{l_t'} = m_a$ for $l_t, l_t', l_t'' = r_t - A + 1, \dots, r_t$ (corresponding to a $U(A)$ gauge group). The potentials contain the mass terms:

$$\begin{aligned}
V_{sc,t} \ni & + \bar{\phi}_{N_f, k_t''} \left(\delta_{k_t'}^{k_t''} m_{N_f}^{N_f} + \sigma_{k_t'}^{k_t''} \delta_{N_f}^{N_f} \right) \left(\delta_{k_t}^{k_t'} m_{N_f}^{N_f} + \sigma_{k_t}^{k_t'} \delta_{N_f}^{N_f} \right) \phi^{N_f, k_t} \\
& + \bar{\tilde{\phi}}_{N_f, k_t''} \left(\delta_{k_t'}^{k_t''} \tilde{m}_{N_f}^{N_f} - \sigma_{k_t'}^{k_t''} \delta_{N_f}^{N_f} \right) \left(\delta_{k_t}^{k_t'} \tilde{m}_{N_f}^{N_f} - \sigma_{k_t}^{k_t'} \delta_{N_f}^{N_f} \right) \tilde{\phi}^{N_f, k_t} \\
& + \bar{\phi}_{N_f, l_t''} \left(\delta_{l_t'}^{l_t''} m_{N_f}^{N_f} + \sigma_{l_t'}^{l_t''} \delta_{N_f}^{N_f} \right) \left(\delta_{l_t}^{l_t'} m_{N_f}^{N_f} + \sigma_{l_t}^{l_t'} \delta_{N_f}^{N_f} \right) \phi^{N_f, l_t} \\
& + \bar{\tilde{\phi}}_{N_f, l_t''} \left(\delta_{l_t'}^{l_t''} \tilde{m}_{N_f}^{N_f} - \sigma_{l_t'}^{l_t''} \delta_{N_f}^{N_f} \right) \left(\delta_{l_t}^{l_t'} \tilde{m}_{N_f}^{N_f} - \sigma_{l_t}^{l_t'} \delta_{N_f}^{N_f} \right) \tilde{\phi}^{N_f, l_t} \\
& + \bar{\phi}_{\bar{i}'', k_t'} \left(\delta_{k_t}^{k_t'} m_{\bar{i}''}^{\bar{i}''} + \sigma_{k_t}^{k_t'} \delta_{\bar{i}''}^{\bar{i}''} \right) \left(\delta_{k_t}^{k_t'} m_{\bar{i}}^{\bar{i}} + \sigma_{k_t}^{k_t'} \delta_{\bar{i}}^{\bar{i}} \right) \phi^{\bar{i}, k_t} \\
& + \bar{\tilde{\phi}}_{\bar{i}'', k_t'} \left(\delta_{k_t}^{k_t'} \tilde{m}_{\bar{i}''}^{\bar{i}''} - \sigma_{k_t}^{k_t'} \delta_{\bar{i}''}^{\bar{i}''} \right) \left(\delta_{k_t}^{k_t'} \tilde{m}_{\bar{i}}^{\bar{i}} - \sigma_{k_t}^{k_t'} \delta_{\bar{i}}^{\bar{i}} \right) \tilde{\phi}^{\bar{i}, k_t} \\
& + \bar{\phi}_{\bar{i}'', l_t'} \left(\delta_{l_t}^{l_t'} m_{\bar{i}''}^{\bar{i}''} + \sigma_{l_t}^{l_t'} \delta_{\bar{i}''}^{\bar{i}''} \right) \left(\delta_{l_t}^{l_t'} m_{\bar{i}}^{\bar{i}} + \sigma_{l_t}^{l_t'} \delta_{\bar{i}}^{\bar{i}} \right) \phi^{\bar{i}, l_t} \\
& + \bar{\tilde{\phi}}_{\bar{i}'', l_t'} \left(\delta_{l_t}^{l_t'} \tilde{m}_{\bar{i}''}^{\bar{i}''} - \sigma_{l_t}^{l_t'} \delta_{\bar{i}''}^{\bar{i}''} \right) \left(\delta_{l_t}^{l_t'} \tilde{m}_{\bar{i}}^{\bar{i}} - \sigma_{l_t}^{l_t'} \delta_{\bar{i}}^{\bar{i}} \right) \tilde{\phi}^{\bar{i}, l_t}
\end{aligned} \tag{9.18}$$

Since the N_f^{th} flavour is massive, the brackets of the first four terms are nonzero. In order for the potentials to be minimised, this leads to the constraint $\phi^{N_f, k_t}, \tilde{\phi}^{N_f, k_t}, \phi^{N_f, l_t}, \tilde{\phi}^{N_f, l_t} = 0$. In the first two terms, $\sigma_{k_t'}^{k_t''} = \sigma_{k_t}^{k_t'} = 0$. Subsequently, the fields $\phi^{N_f, k_t}, \tilde{\phi}^{N_f, k_t}$ are made to have the same mass m_a by imposing $m_{N_f}^{N_f} = \tilde{m}_{N_f}^{N_f} = m_a$. This corresponds to one flavour of matter and antimatter, with mass m_a , transforming in the fundamental and antifundamental of $U(r_t - A)$ respectively. Since $m_{N_f}^{N_f} = \tilde{m}_{N_f}^{N_f} = m_a$ and $\sigma_{l_t'}^{l_t''} = \sigma_{l_t}^{l_t'} = m_a$, the third and fourth terms give rise to one flavour of massive matter with mass $2m_a$ and antimatter with mass 0 in the fundamental and antifundamental of $U(A)$ respectively. Since $m_{\bar{i}''}^{\bar{i}''} = m_{\bar{i}}^{\bar{i}} = \tilde{m}_{\bar{i}''}^{\bar{i}''} = \tilde{m}_{\bar{i}}^{\bar{i}} = 0$ and $\sigma_{k_t}^{k_t'} = \sigma_{k_t}^{k_t'} = 0$, the fifth and sixth terms give rise to $N_f - 1$ flavours of massless matter and antimatter in the fundamental and antifundamental of $U(r_t - A)$ respectively. Since $m_{\bar{i}''}^{\bar{i}''} = m_{\bar{i}}^{\bar{i}} = \tilde{m}_{\bar{i}''}^{\bar{i}''} = \tilde{m}_{\bar{i}}^{\bar{i}} = 0$ and $\sigma_{l_t}^{l_t'} = \sigma_{l_t}^{l_t'} = m_a$, the seventh and eighth terms give rise to $N_f - 1$ flavours matter with mass m_a and antimatter with mass $-m_a$ in the fundamental and antifundamental of $U(A)$ respectively.

With the inclusion of adjoint matter, the higher energy theory contains the gauge groups:

$$U(r_1 - A)_k \times U(r_2 - A)_k \times \dots \times U(r_n - A)_k \times U(A)_k^n \quad (9.19)$$

where, for the $U(A)$ the superscript n is a power. The $U(r_t - A)$ groups have one flavour of massive matter and antimatter with mass m_a and $N_f - 1$ flavours of massless matter and antimatter. The $U(A)^n$ groups have one flavour of matter with mass $2m_a$ and one flavour of antimatter with mass 0. The $U(A)^n$ groups also have $N_f - 1$ flavours of matter with mass m_a and $N_f - 1$ flavours of antimatter with mass $-m_a$. Integrating out the massive matter and antimatter gives a low energy theory with gauge groups:

$$U(r_1 - A)_{k+1} \times U(r_2 - A)_{k+1} \times \dots \times U(r_n - A)_{k+1} \times U(A)_{k+\frac{1}{2}}^n \quad (9.20)$$

Only the massless matter and antimatter remains in the resulting theory.

Aharony and Giveon-Kutasov Duality:

$k = -1$) The high energy theory is:

$$U(r_1 - A)_{-1} \times U(r_2 - A)_{-1} \times \dots \times U(r_n - A)_{-1} \times U(A)_{-1}^n \quad (9.21)$$

The low energy theory is:

$$U(r_1 - A)_0 \times U(r_2 - A)_0 \times \dots \times U(r_n - A)_0 \times U(A)_{-\frac{1}{2}}^n \quad (9.22)$$

The $U(r_t - A)$ groups experience a flow from Giveon-Kutasov to Aharony duality. The $U(A)^n$ groups experience no such flow and exhibit Giveon-Kutasov duality at low energies.

$k = -\frac{1}{2}$) The high energy theory is:

$$U(r_1 - A)_{-\frac{1}{2}} \times U(r_2 - A)_{-\frac{1}{2}} \times \dots \times U(r_n - A)_{-\frac{1}{2}} \times U(A)_{-\frac{1}{2}}^n \quad (9.23)$$

The low energy theory is:

$$U(r_1 - A)_{\frac{1}{2}} \times U(r_2 - A)_{\frac{1}{2}} \times \dots \times U(r_n - A)_{\frac{1}{2}} \times U(A)_{\frac{1}{2}}^n \quad (9.24)$$

The $U(r_t - A)$ groups experience no flow between dualities and exhibit Giveon-Kutasov duality at low energies. The $U(A)^n$ groups experience a flow from Giveon-Kutasov to Aharony duality.

$k = 0$) The high energy theory is:

$$U(r_1 - A)_0 \times U(r_2 - A)_0 \times \dots \times U(r_n - A)_0 \times U(A)_0^n \quad (9.25)$$

The low energy theory is:

$$U(r_1 - A)_1 \times U(r_2 - A)_1 \times \dots \times U(r_n - A)_1 \times U(A)_{\frac{1}{2}}^n \quad (9.26)$$

The $U(r_t - A)$ and the $U(A)^n$ groups experience a flow from Aharony to Giveon-Kutasov duality.

$k \neq -1, -\frac{1}{2}, 0$) There is no flow between dualities. The low energy theory exhibits Giveon-Kutasov duality.

9.1.3 Some σ Components are Negative

The N_f^{th} flavour of matter is massive, and the indices $\bar{i}, \bar{i}', \bar{i}'' = 1, \dots, N_f - 1$ are used to denote the massless flavours. Consider the case where $\sigma_{k_t}^{k_t''} = \sigma_{k_t}^{k_t'} = 0$ for $k_t, k_t', k_t'' = 1, \dots, r_t - A$ (corresponding to a $U(r_t - A)$ gauge group), and where $\sigma_{l_t}^{l_t''} = \sigma_{l_t}^{l_t'} = -m_a$ for $l_t, l_t', l_t'' = r_t - A + 1, \dots, r_t$ (corresponding to a $U(A)$ gauge group). The potentials contain the mass terms:

$$\begin{aligned} V_{sc,t} = & \bar{\phi}_{N_f, k_t''} \left(\delta_{k_t}^{k_t''} m_{N_f}^{N_f} + \sigma_{k_t}^{k_t''} \delta_{N_f}^{N_f} \right) \left(\delta_{k_t}^{k_t'} m_{N_f}^{N_f} + \sigma_{k_t}^{k_t'} \delta_{N_f}^{N_f} \right) \phi_{N_f, k_t} \\ & + \bar{\phi}_{N_f, k_t''} \left(\delta_{k_t}^{k_t''} \tilde{m}_{N_f}^{N_f} - \sigma_{k_t}^{k_t''} \delta_{N_f}^{N_f} \right) \left(\delta_{k_t}^{k_t'} \tilde{m}_{N_f}^{N_f} - \sigma_{k_t}^{k_t'} \delta_{N_f}^{N_f} \right) \tilde{\phi}_{N_f, k_t} \\ & + \bar{\phi}_{N_f, l_t''} \left(\delta_{l_t}^{l_t''} m_{N_f}^{N_f} + \sigma_{l_t}^{l_t''} \delta_{N_f}^{N_f} \right) \left(\delta_{l_t}^{l_t'} m_{N_f}^{N_f} + \sigma_{l_t}^{l_t'} \delta_{N_f}^{N_f} \right) \phi_{N_f, l_t} \\ & + \bar{\phi}_{N_f, l_t''} \left(\delta_{l_t}^{l_t''} \tilde{m}_{N_f}^{N_f} - \sigma_{l_t}^{l_t''} \delta_{N_f}^{N_f} \right) \left(\delta_{l_t}^{l_t'} \tilde{m}_{N_f}^{N_f} - \sigma_{l_t}^{l_t'} \delta_{N_f}^{N_f} \right) \tilde{\phi}_{N_f, l_t} \\ & + \bar{\phi}_{\bar{i}'', k_t} \left(\delta_{k_t}^{k_t'} m_{\bar{i}''}^{\bar{i}''} + \sigma_{k_t}^{k_t'} \delta_{\bar{i}''}^{\bar{i}''} \right) \left(\delta_{k_t}^{k_t'} m_{\bar{i}'}^{\bar{i}'} + \sigma_{k_t}^{k_t'} \delta_{\bar{i}'}^{\bar{i}'} \right) \phi^{\bar{i}, k_t} \\ & + \bar{\phi}_{\bar{i}'', k_t} \left(\delta_{k_t}^{k_t'} \tilde{m}_{\bar{i}''}^{\bar{i}''} - \sigma_{k_t}^{k_t'} \delta_{\bar{i}''}^{\bar{i}''} \right) \left(\delta_{k_t}^{k_t'} \tilde{m}_{\bar{i}'}^{\bar{i}'} - \sigma_{k_t}^{k_t'} \delta_{\bar{i}'}^{\bar{i}'} \right) \tilde{\phi}^{\bar{i}, k_t} \\ & + \bar{\phi}_{\bar{i}'', l_t} \left(\delta_{l_t}^{l_t'} m_{\bar{i}''}^{\bar{i}''} + \sigma_{l_t}^{l_t'} \delta_{\bar{i}''}^{\bar{i}''} \right) \left(\delta_{l_t}^{l_t'} m_{\bar{i}'}^{\bar{i}'} + \sigma_{l_t}^{l_t'} \delta_{\bar{i}'}^{\bar{i}'} \right) \phi^{\bar{i}, l_t} \\ & + \bar{\phi}_{\bar{i}'', l_t} \left(\delta_{l_t}^{l_t'} \tilde{m}_{\bar{i}''}^{\bar{i}''} - \sigma_{l_t}^{l_t'} \delta_{\bar{i}''}^{\bar{i}''} \right) \left(\delta_{l_t}^{l_t'} \tilde{m}_{\bar{i}'}^{\bar{i}'} - \sigma_{l_t}^{l_t'} \delta_{\bar{i}'}^{\bar{i}'} \right) \tilde{\phi}^{\bar{i}, l_t} \end{aligned} \quad (9.27)$$

Since the N_f^{th} flavour is massive, the brackets of the first four terms are non-zero. In order for the potentials to be minimised, this leads to the constraint ϕ^{N_f, k_t} ,

$\tilde{\phi}^{N_f, k_t}, \phi^{N_f, l_t}, \tilde{\phi}^{N_f, l_t} = 0$. In the first two terms, $\sigma_{k_t}^{k_t''} = \sigma_{k_t}^{k_t'} = 0$. Subsequently, the fields $\phi^{N_f, k_t}, \tilde{\phi}^{N_f, k_t}$ are made to have the same mass m_a by imposing $m_{N_f}^{N_f} = \tilde{m}_{N_f}^{N_f} = m_a$. This corresponds to one flavour of matter and antimatter, with mass m_a , transforming in the fundamental and antifundamental of $U(r_t - A)$ respectively. Since $m_{N_f}^{N_f} = \tilde{m}_{N_f}^{N_f} = m_a$ and $\sigma_{l_t}^{l_t''} = \sigma_{l_t}^{l_t'} = -m_a$, the third and fourth terms give rise to one flavour of matter with mass 0 and antimatter with mass $2m_a$ in the fundamental and antifundamental of $U(A)$ respectively. Since $m_{\bar{i}'}^{i''} = m_{\bar{i}'}^{i'} = \tilde{m}_{\bar{i}'}^{i''} = \tilde{m}_{\bar{i}'}^{i'} = 0$ and $\sigma_{k_t}^{k_t''} = \sigma_{k_t}^{k_t'} = 0$, the fifth and sixth terms give rise to $N_f - 1$ flavours of massless matter and antimatter in the fundamental and antifundamental of $U(r_t - A)$ respectively. Since $m_{\bar{i}'}^{i''} = m_{\bar{i}'}^{i'} = \tilde{m}_{\bar{i}'}^{i''} = \tilde{m}_{\bar{i}'}^{i'} = 0$ and $\sigma_{l_t}^{l_t''} = \sigma_{l_t}^{l_t'} = -m_a$, the seventh and eighth terms give rise to $N_f - 1$ flavours matter with mass $-m_a$ and antimatter with mass m_a in the fundamental and antifundamental of $U(A)$ respectively.

With the inclusion of adjoint matter, the higher energy theory contains the gauge groups:

$$U(r_1 - A)_k \times U(r_2 - A)_k \times \dots \times U(r_n - A)_k \times U(A)_k^n \quad (9.28)$$

where, for the $U(A)$ the superscript n is a power. The $U(r_t - A)$ groups have one flavour of massive matter and antimatter with mass m_a and $N_f - 1$ flavours of massless matter and antimatter. The $U(A)_k^n$ groups have one flavour of matter with mass 0 and one flavour of antimatter with mass $2m_a$. The $U(A)_k^n$ groups also have $N_f - 1$ flavours of matter with mass $-m_a$ and $N_f - 1$ flavours of antimatter with mass m_a . Integrating out the massive matter and antimatter gives a low energy theory with gauge groups:

$$U(r_1 - A)_{k+1} \times U(r_2 - A)_{k+1} \times \dots \times U(r_n - A)_{k+1} \times U(A)_{k+\frac{1}{2}}^n \quad (9.29)$$

Only the massless matter remains in the resulting theory.

Aharony and Giveon-Kutasov Duality:

The flow between dualities are the same as in the previous section.

$k = -1$) The high energy theory is:

$$U(r_1 - A)_{-1} \times U(r_2 - A)_{-1} \times \dots \times U(r_n - A)_{-1} \times U(A)_{-1}^n \quad (9.30)$$

The low energy theory is:

$$U(r_1 - A)_0 \times U(r_2 - A)_0 \times \dots \times U(r_n - A)_0 \times U(A)_{-\frac{1}{2}}^n \quad (9.31)$$

The $U(r_t - A)$ groups experience a flow from Giveon-Kutasov to Aharony duality. The $U(A)^n$ groups experience no such flow and exhibit Giveon-Kutasov duality at low energies.

$k = -\frac{1}{2}$) The high energy theory is:

$$U(r_1 - A)_{-\frac{1}{2}} \times U(r_2 - A)_{-\frac{1}{2}} \times \dots \times U(r_n - A)_{-\frac{1}{2}} \times U(A)_{-\frac{1}{2}}^n \quad (9.32)$$

The low energy theory is:

$$U(r_1 - A)_{\frac{1}{2}} \times U(r_2 - A)_{\frac{1}{2}} \times \dots \times U(r_n - A)_{\frac{1}{2}} \times U(A)_0^n \quad (9.33)$$

The $U(r_t - A)$ groups experience no flow between dualities and exhibit Giveon-Kutasov duality at low energies. The $U(A)^n$ groups experience a flow from Giveon-Kutasov to Aharony duality.

$k = 0$) The high energy theory is:

$$U(r_1 - A)_0 \times U(r_2 - A)_0 \times \dots \times U(r_n - A)_0 \times U(A)_0^n \quad (9.34)$$

The low energy theory is:

$$U(r_1 - A)_1 \times U(r_2 - A)_1 \times \dots \times U(r_n - A)_1 \times U(A)_{\frac{1}{2}}^n \quad (9.35)$$

The $U(r_t - A)$ and the $U(A)^n$ groups experience a flow from Aharony to Giveon-Kutasov duality.

$k \neq -1, -\frac{1}{2}, 0$) There is no flow between dualities. The low energy theory exhibits Giveon-Kutasov duality for all gauge groups.

9.1.4 Some σ_k^j Components are Positive and Some σ_k^j Components are Negative

The N_f^{th} flavour of matter is massive, and the indices $\bar{i}, \bar{i}', \bar{i}'' = 1, \dots, N_f - 1$ are used to denote the massless flavours. Consider the case where $\sigma_{k_t'}^{k_t''} = \sigma_{k_t}^{k_t'} = 0$ for $k_t, k_t', k_t'' = 1, \dots, r_t - A$ (corresponding to a $U(r_t - A)$ gauge group), where

$\sigma_{m_t}^{m_t''} = \sigma_{m_t}^{m_t'} = m_a$ for $m_t, m_t', m_t'' = r_t - A + 1, \dots, r_t - B$ ($A > B$) (corresponding to a $U(A - B)$ gauge group), and where $\sigma_{n_t}^{n_t''} = \sigma_{n_t}^{n_t'} = m_a$ for $n_t, n_t', n_t'' = r_t - B + 1, \dots, r_t$ (corresponding to a $U(B)$ gauge group). The potentials contain the mass terms:

$$\begin{aligned}
V_{sc,t} \ni & + \bar{\phi}_{N_f, k_t}'' \left(\delta_{k_t}^{k_t''} m_{N_f}^{N_f} + \sigma_{k_t}^{k_t''} \delta_{N_f}^{N_f} \right) \left(\delta_{k_t}^{k_t'} m_{N_f}^{N_f} + \sigma_{k_t}^{k_t'} \delta_{N_f}^{N_f} \right) \phi^{N_f, k_t} \\
& + \bar{\phi}_{N_f, k_t}'' \left(\delta_{k_t}^{k_t''} \tilde{m}_{N_f}^{N_f} - \sigma_{k_t}^{k_t''} \delta_{N_f}^{N_f} \right) \left(\delta_{k_t}^{k_t'} \tilde{m}_{N_f}^{N_f} - \sigma_{k_t}^{k_t'} \delta_{N_f}^{N_f} \right) \tilde{\phi}^{N_f, k_t} \\
& + \bar{\phi}_{N_f, m_t}'' \left(\delta_{m_t}^{m_t''} m_{N_f}^{N_f} + \sigma_{m_t}^{m_t''} \delta_{N_f}^{N_f} \right) \left(\delta_{m_t}^{m_t'} m_{N_f}^{N_f} + \sigma_{m_t}^{m_t'} \delta_{N_f}^{N_f} \right) \phi^{N_f, m_t} \\
& + \bar{\phi}_{N_f, m_t}'' \left(\delta_{m_t}^{m_t''} \tilde{m}_{N_f}^{N_f} - \sigma_{m_t}^{m_t''} \delta_{N_f}^{N_f} \right) \left(\delta_{m_t}^{m_t'} \tilde{m}_{N_f}^{N_f} - \sigma_{m_t}^{m_t'} \delta_{N_f}^{N_f} \right) \tilde{\phi}^{N_f, m_t} \\
& + \bar{\phi}_{N_f, n_t}'' \left(\delta_{n_t}^{n_t''} m_{N_f}^{N_f} + \sigma_{n_t}^{n_t''} \delta_{N_f}^{N_f} \right) \left(\delta_{n_t}^{n_t'} m_{N_f}^{N_f} + \sigma_{n_t}^{n_t'} \delta_{N_f}^{N_f} \right) \phi^{N_f, n_t} \\
& + \bar{\phi}_{N_f, n_t}'' \left(\delta_{n_t}^{n_t''} \tilde{m}_{N_f}^{N_f} - \sigma_{n_t}^{n_t''} \delta_{N_f}^{N_f} \right) \left(\delta_{n_t}^{n_t'} \tilde{m}_{N_f}^{N_f} - \sigma_{n_t}^{n_t'} \delta_{N_f}^{N_f} \right) \tilde{\phi}^{N_f, n_t} \\
& + \bar{\phi}_{\bar{i}', k_t}'' \left(\delta_{k_t}^{k_t''} m_{\bar{i}'}^{\bar{i}'} + \sigma_{k_t}^{k_t''} \delta_{\bar{i}'}^{\bar{i}'} \right) \left(\delta_{k_t}^{k_t'} m_{\bar{i}'}^{\bar{i}'} + \sigma_{k_t}^{k_t'} \delta_{\bar{i}'}^{\bar{i}'} \right) \phi^{\bar{i}, k_t} \\
& + \bar{\phi}_{\bar{i}', k_t}'' \left(\delta_{k_t}^{k_t''} \tilde{m}_{\bar{i}'}^{\bar{i}'} - \sigma_{k_t}^{k_t''} \delta_{\bar{i}'}^{\bar{i}'} \right) \left(\delta_{k_t}^{k_t'} \tilde{m}_{\bar{i}'}^{\bar{i}'} - \sigma_{k_t}^{k_t'} \delta_{\bar{i}'}^{\bar{i}'} \right) \tilde{\phi}^{\bar{i}, k_t} \\
& + \bar{\phi}_{\bar{i}', m_t}'' \left(\delta_{m_t}^{m_t''} m_{\bar{i}'}^{\bar{i}'} + \sigma_{m_t}^{m_t''} \delta_{\bar{i}'}^{\bar{i}'} \right) \left(\delta_{m_t}^{m_t'} m_{\bar{i}'}^{\bar{i}'} + \sigma_{m_t}^{m_t'} \delta_{\bar{i}'}^{\bar{i}'} \right) \phi^{\bar{i}, m_t} \\
& + \bar{\phi}_{\bar{i}', m_t}'' \left(\delta_{m_t}^{m_t''} \tilde{m}_{\bar{i}'}^{\bar{i}'} - \sigma_{m_t}^{m_t''} \delta_{\bar{i}'}^{\bar{i}'} \right) \left(\delta_{m_t}^{m_t'} \tilde{m}_{\bar{i}'}^{\bar{i}'} - \sigma_{m_t}^{m_t'} \delta_{\bar{i}'}^{\bar{i}'} \right) \tilde{\phi}^{\bar{i}, m_t} \\
& + \bar{\phi}_{\bar{i}', n_t}'' \left(\delta_{n_t}^{n_t''} m_{\bar{i}'}^{\bar{i}'} + \sigma_{n_t}^{n_t''} \delta_{\bar{i}'}^{\bar{i}'} \right) \left(\delta_{n_t}^{n_t'} m_{\bar{i}'}^{\bar{i}'} + \sigma_{n_t}^{n_t'} \delta_{\bar{i}'}^{\bar{i}'} \right) \phi^{\bar{i}, n_t} \\
& + \bar{\phi}_{\bar{i}', n_t}'' \left(\delta_{n_t}^{n_t''} \tilde{m}_{\bar{i}'}^{\bar{i}'} - \sigma_{n_t}^{n_t''} \delta_{\bar{i}'}^{\bar{i}'} \right) \left(\delta_{n_t}^{n_t'} \tilde{m}_{\bar{i}'}^{\bar{i}'} - \sigma_{n_t}^{n_t'} \delta_{\bar{i}'}^{\bar{i}'} \right) \tilde{\phi}^{\bar{i}, n_t}
\end{aligned} \tag{9.36}$$

The N_f^{th} flavour is massive, which means that the brackets of the first six terms are non-zero. In order for the potentials to be minimised, this leads to the constraint $\phi^{N_f, k_t}, \tilde{\phi}^{N_f, k_t}, \phi^{N_f, m_t}, \tilde{\phi}^{N_f, m_t}, \phi^{N_f, n_t}, \tilde{\phi}^{N_f, n_t} = 0$. In the first two terms, $\sigma_{k_t}^{k_t''} = \sigma_{k_t}^{k_t'} = 0$. Subsequently, the fields $\phi^{N_f, k_t}, \tilde{\phi}^{N_f, k_t}$ are made to have the same mass m_a by imposing $m_{N_f}^{N_f} = \tilde{m}_{N_f}^{N_f} = m_a$. This corresponds to one flavour of matter and antimatter, with mass m_a , transforming in the fundamental and antifundamental of $U(r_t - A)$ respectively. Since $m_{N_f}^{N_f} = \tilde{m}_{N_f}^{N_f} = m_a$ and $\sigma_{m_t}^{m_t''} = \sigma_{m_t}^{m_t'} = m_a$, the third and fourth terms give rise to one flavour of matter with mass $2m_a$ and antimatter with mass 0 in the fundamental and antifundamental of $U(A - B)$ respectively. Since $m_{N_f}^{N_f} = \tilde{m}_{N_f}^{N_f} = m_a$ and $\sigma_{n_t}^{n_t''} = \sigma_{n_t}^{n_t'} = -m_a$, the fifth and sixth terms give rise to one flavour of matter with mass 0 and antimatter with mass $2m_a$ in the fundamental and antifundamental of $U(B)$ respectively. The seventh and eighth terms out of the trace give rise to $N_f - 1$ flavours of massless matter and antimatter in the fundamental and antifundamental of $U(r_t - A)$ respectively. The ninth and tenth terms out of the trace give rise to $N_f - 1$ flavours matter with mass m_a and antimatter with mass $-m_a$ in the fundamental and antifundamental of $U(A - B)$ respectively. The eleventh and twelfth terms out of the trace give rise to $N_f - 1$ flavours matter with mass $-m_a$ and

antimatter with mass m_a in the fundamental and antifundamental of $U(B)$ respectively.

With the inclusion of adjoint matter, the high energy theory contains the gauge groups:

$$U(r_1 - A)_k \times U(r_2 - A)_k \times \dots \times U(r_n - A)_k \times U(A - B)_k^n \times U(B)_k^n \quad (9.37)$$

where the superscript n is a power. The $U(r_t - A)$ groups have one flavour of massive matter and antimatter with mass m_a and $N_f - 1$ flavours of massless matter and antimatter. The $U(A - B)^n$ groups have one flavour of matter with mass $2m_a$ and one flavour of antimatter with mass 0. The $U(A - B)^n$ groups also have $N_f - 1$ flavours of matter with mass m_a and $N_f - 1$ flavours of antimatter with mass $-m_a$. The $U(B)^n$ groups have one flavour of matter with mass 0 and one flavour of antimatter with mass $2m_a$. The $U(B)^n$ groups also have $N_f - 1$ flavours of matter with mass $-m_a$ and $N_f - 1$ flavours of antimatter with mass m_a . Integrating out the massive matter and antimatter gives a low energy theory with gauge groups:

$$U(r_1 - A)_{k+1} \times U(r_2 - A)_{k+1} \times \dots \times U(r_n - A)_{k+1} \times U(A - B)_{k+\frac{1}{2}}^n \times U(B)_{k+\frac{1}{2}}^n \quad (9.38)$$

Only the massless matter remains in the resulting theory.

Aharony and Giveon-Kutasov Duality:

The flow between dualities are the same as in the previous section.

$k = -1$) The high energy theory is:

$$U(r_1 - A)_{-1} \times U(r_2 - A)_{-1} \times \dots \times U(r_n - A)_{-1} \times U(A - B)_{-1}^n \times U(B)_{-1}^n \quad (9.39)$$

The low energy theory is:

$$U(r_1 - A)_0 \times U(r_2 - A)_0 \times \dots \times U(r_n - A)_0 \times U(A - B)_{-\frac{1}{2}}^n \times U(B)_{-\frac{1}{2}}^n \quad (9.40)$$

The $U(r_t - A)$ groups experience a flow from Giveon-Kutasov to Aharony duality.

The $U(A - B)^n$ and $U(B)^n$ groups experience no such flow and exhibit Giveon-Kutasov duality at low energies.

$k = -\frac{1}{2}$) The high energy theory is:

$$U(r_1 - A)_{-\frac{1}{2}} \times U(r_2 - A)_{-\frac{1}{2}} \times \dots \times U(r_n - A)_{-\frac{1}{2}} \times U(A - B)_{-\frac{1}{2}}^n \times U(B)_{-\frac{1}{2}}^n \quad (9.41)$$

The low energy theory is:

$$U(r_1 - A)_{\frac{1}{2}} \times U(r_2 - A)_{\frac{1}{2}} \times \dots \times U(r_n - A)_{\frac{1}{2}} \times U(A - B)_0^n \times U(B)_0^n \quad (9.42)$$

The $U(r_t - A)$ groups experience no flow between dualities and exhibit Giveon-Kutasov duality at low energies. The $U(A - B)^n$ and $U(B)^n$ groups experience a flow from Giveon-Kutasov to Aharony duality.

$k = 0$) The high energy theory is:

$$U(r_1 - A)_0 \times U(r_2 - A)_0 \times \dots \times U(r_n - A)_0 \times U(A)_0^n \times U(B)_0^n \quad (9.43)$$

The low energy theory is:

$$U(r_1 - A)_1 \times U(r_2 - A)_1 \times \dots \times U(r_n - A)_1 \times U(A - B)_{\frac{1}{2}}^n \times U(B)_{\frac{1}{2}}^n \quad (9.44)$$

The $U(r_t - A)$, $U(A - B)^n$, $U(B)^n$ groups experience a flow from Aharony to Giveon-Kutasov duality.

$k \neq -1, -\frac{1}{2}, 0$) There is no flow between dualities. The low energy theory exhibits Giveon-Kutasov duality for all gauge groups.

9.2 Generalisations

It is clear that such theories can be made arbitrarily complicated. For example, a different number of massive flavours could be considered for different values of t . Alternatively, the values of $m_i^{i'}$ components need not match the corresponding values of $\tilde{m}_i^{i'}$. In general this would lead to matter and antimatter with different absolute values of their masses. Another generalisation would be the addition of more massive flavours. This would be accompanied by an exponential increase in the possible combinations of parameter values. The previous section is only intended to provide a taste of the possible scenarios, and the flows between dualities that result.

Part IV

Discussion

Numerous examples of brane configurations have been considered, and the low energy theories analysed. The dualities present in the low energy theories have also been discussed. It is clear that there is considerable freedom to change the outcome of the low energy theories through choices made in the brane configurations. The brane configurations can be made arbitrarily complicated through the displacement of more D5-branes, the displacement of more D3-branes, and increasingly large webs of branes (to mention just a few methods). The results presented above provide some insight into the complicated theories that can arise.

One practical issue occurred when displacing the D3-branes. Their orientations had to remain along the (x_1, x_2, x_6) spatial directions in order to preserve supersymmetry. Furthermore, they were required to have finite length in the x_6 , so that their x_6 extent could be taken to be small and dimensional reduction from $(1 + 3)d$ to $(1 + 2)d$ could occur. The only way to achieve this was to have them end on entirely new branes, leading to the introduction of extra NS5-branes (see figure 17). These branes are introduced very artificially, but are nonetheless necessary.

For many of the gauge groups, integrating out massive matter led to fractional Chern-Simons levels. Whilst there are some special cases that permit the occurrence of fractional level, such theories are not discussed here. Therefore, the requirement for integer level imposes further restrictions on the brane configurations. Specifically, in section 8.1, only the case of no displaced D3-branes is permitted. This is because the other cases introduce fractional Chern-Simons level in the effective field theories. On the other hand, all cases discussed in section 8.2 are permitted, as Chern-Simons levels are only shifted by integer values for all gauge groups. For the results of section 8.3, again, it is only the case where no D3-branes are displaced that is permitted.

Additionally, flows between dualities for theories with adjoint matter were discussed in section 9, giving an idea of how theories with different dualities can be obtained.

There are many new direction in which the research can be taken. For example, Dr Radu Tatar and I are currently investigating flows between dualities for theories with bifundamental matter. Such theories are obtained from string theory by considering two stacks of D3-branes ending on either side of NS5-branes. It would also be interesting to draw the Aharony or the Giveon-Kutasov dual configurations of the brane configurations mentioned in the results section. Additionally, the brane configurations corresponding to the theories with adjoint matter could be investigated, together with their dual configurations.

Part V

Appendices

A Lightcone Gauge

Quantising the theory using lightcone gauge provides new and useful insights to the string theory. First lightcone gauge must be explained:

In string theory there exists a class of gauge choices obtained by imposing [1]:

$$\begin{aligned} n \cdot X(\sigma^0, \sigma^1) &= \frac{1}{\pi T} (n \cdot p) \sigma^0 \\ (n \cdot p) \sigma^1 &= \pi \int_0^\sigma d\sigma^1 n \cdot \mathcal{P}^0(\sigma^0, \sigma^1) \end{aligned} \tag{A.1}$$

for open strings, and:

$$\begin{aligned} n \cdot X(\sigma^0, \sigma^1) &= \frac{1}{2\pi T} (n \cdot p) \sigma^0 \\ (n \cdot p) \sigma^1 &= 2\pi \int_0^\sigma d\sigma^1 n \cdot \mathcal{P}^0(\sigma^0, \sigma^1) \end{aligned} \tag{A.2}$$

for closed strings.

Lightcone gauge is then obtained by imposing the above gauge choices and choosing [1]:

$$n^\mu = \left(\frac{1}{\sqrt{2}}, \frac{1}{\sqrt{2}}, 0, \dots, 0 \right) \tag{A.3}$$

This choice gives [1]:

$$n \cdot X = \frac{1}{\sqrt{2}} (X^0 + X^1) = X^+ \tag{A.4}$$

$$n \cdot p = \frac{1}{\sqrt{2}} (p^0 + p^1) = p^+ \tag{A.5}$$

Also:

$$X^- = \frac{1}{\sqrt{2}} (X^0 - X^1) \tag{A.6}$$

$$p^- = \frac{1}{\sqrt{2}} (p^0 - p^1) \tag{A.7}$$

The string coordinates in the bulk are then given by:

$$(X^+, X^-, X^I) \tag{A.8}$$

where

$$X^I = (X^2, \dots, X^D) \tag{A.9}$$

are called the ‘transverse coordinates’.

In these coordinates the X expansions are given by [1]:

$$X^+ (\sigma^0, \sigma^1) = 2\alpha' p^+ \sigma^0 = \sqrt{2\alpha'} \alpha_0^+ \sigma^0 \tag{A.10}$$

$$X^- (\sigma^0, \sigma^1) = x_0^- + \sqrt{2\alpha'} \alpha_0^- \sigma^0 + i\sqrt{2\alpha'} \sum_{n \neq 0} \frac{1}{n} \alpha_n^- e^{-in\sigma^0} \cos(n\sigma^1) \tag{A.11}$$

$$X^I (\sigma^0, \sigma^1) = x_0^I + \sqrt{2\alpha'} \alpha_0^I \sigma^0 + i\sqrt{2\alpha'} \sum_{n \neq 0} \frac{1}{n} \alpha_n^I e^{-in\sigma^0} \cos(n\sigma^1) \tag{A.12}$$

In lightcone gauge the transverse Virasoro operators are given by [1]:

$$L_n^\perp = \frac{1}{2} \sum_{p=-\infty}^{\infty} \alpha_{n-p}^I \alpha_p^I \quad (n, p \in \mathbb{Z}) \tag{A.13}$$

L_0^\perp is given in normal ordered form as [1]:

$$L_0^\perp = \frac{1}{2} \alpha_0^I \alpha_0^I + \sum_{p=1}^{\infty} \alpha_{-p}^I \alpha_p^I + \frac{1}{2} (D-2) \sum_{p=1}^{\infty} p \tag{A.14}$$

As in the canonical case, it is then redefined without the normal ordering constant:

$$L_0^\perp \equiv \frac{1}{2} \alpha_0^I \alpha_0^I + \sum_{p=1}^{\infty} \alpha_{-p}^I \alpha_p^I \quad (p \in \mathbb{Z}) \tag{A.15}$$

B Three Dimensional $N = 2$ Superfield Conventions

The superfield conventions used are those that appear in the 2008 paper of Benna, Klebanov, Klose and Smedbäck ([33]). The chiral and anti-chiral multiplets are given by:

$$Q = \phi(x_L) + \sqrt{2}\theta\psi(x_L) + \theta^2 F(x_L) \quad (\text{B.1})$$

and

$$\bar{Q} = \phi^\dagger(x_R) - \sqrt{2}\bar{\theta}\bar{\psi}(x_R) - \bar{\theta}^2 F^\dagger(x_R) \quad (\text{B.2})$$

respectively. In the above, $x_L^\mu = x^\mu + i\theta\gamma^\mu\bar{\theta}$ and $x_R^\mu = x^\mu - i\theta\gamma^\mu\bar{\theta}$. In equation B.2, the bar above Q is a symbol that simply means that the the hermitian conjugate of the components of equation B.1 have been taken [33]. $\phi(x_L)$ and $\phi^\dagger(x_R)$ are complex scalars, each having one complex component, or equivalently, two real components. θ , $\bar{\theta}$, $\psi(x_L)$ and $\bar{\psi}(x_R)$ are $(1+2)$ d Dirac spinors, each having two complex components, or equivalently, four real components. F and F^\dagger are complex auxiliary scalars, each have one complex component, or equivalently, two real components. In equation B.2:

$$\bar{\psi} = \psi^\dagger\gamma_0 \quad \text{and} \quad \bar{\theta} = \theta^\dagger\gamma_0 \quad (\text{B.3})$$

are Dirac conjugates of ψ and θ respectively. The dagger denotes the hermitian conjugate. In equations B.1 and B.2:

$$\theta\psi = \theta^\alpha\psi_\alpha, \quad \bar{\theta}\bar{\psi} = \bar{\theta}^\alpha\bar{\psi}_\alpha, \quad \theta^2 = \theta^\alpha\theta_\alpha, \quad \bar{\theta}^2 = \bar{\theta}^\alpha\bar{\theta}_\alpha \quad (\text{B.4})$$

where $\alpha = 1, 2$ is a spinor index. Using:

$$(\theta\psi)^\dagger = -\bar{\theta}\bar{\psi}, \quad (\theta\theta)^\dagger = -\bar{\theta}\bar{\theta} \quad (\text{B.5})$$

it is clear that $\bar{Q} = Q^\dagger$.

Performing a Taylor expansion of equation B.1 gives [36]:

$$\begin{aligned} Q(x_L) = & \phi(x) + i(\theta\gamma^\mu\bar{\theta})\partial_\mu\phi(x) - \frac{1}{4}\theta^2\bar{\theta}^2\Box\phi(x) \\ & + \sqrt{2}(\theta\psi(x)) - \frac{i}{\sqrt{2}}\theta^2((\partial_\mu\psi(x))\gamma^\mu\bar{\theta}) + \theta^2 F(x) \end{aligned} \quad (\text{B.6})$$

Performing a Taylor expansion of equation B.2 gives [36]:

$$\begin{aligned} Q(x_L) = & \phi^\dagger(x) - i(\theta\gamma^\mu\bar{\theta})\partial_\mu\phi^\dagger(x) - \frac{1}{4}\theta^2\bar{\theta}^2\Box\phi^\dagger(x) \\ & - \sqrt{2}(\bar{\theta}\bar{\psi}(x)) - \frac{i}{\sqrt{2}}\bar{\theta}^2(\theta\gamma^\mu(\partial_\mu\bar{\psi}(x))) - \bar{\theta}^2\bar{F}(x) \end{aligned} \quad (\text{B.7})$$

In Wess-Zumino gauge, the vector multiplet is given by [33]:

$$V = 2i (\theta\bar{\theta}) \sigma(x) + 2 (\theta\gamma^\mu\bar{\theta}) A_\mu(x) + \sqrt{2}i\theta^2 (\bar{\theta}\bar{\chi}(x)) - \sqrt{2}i\bar{\theta}^2 (\theta\chi(x)) + \theta^2\bar{\theta}^2 D(x) \quad (\text{B.8})$$

In the above σ is a real scalar, A_μ is a vector gauge field, χ and $\bar{\chi}$ are both two complex component (or equivalently, four real component) Dirac spinors, and D is a real auxiliary scalar. The linear multiplet Σ is defined in terms of V as:

$$\Sigma = \frac{i}{4} \bar{D}^\alpha D_\alpha V \quad (\text{B.9})$$

The vector multiplet also appears in an exponential (in terms of the form $Q^\dagger e^{qV} Q$) so it is important to know how to write the exponential expansion. It is possible to show that:

$$\frac{1}{2} V^2 = \theta^2 \bar{\theta}^2 (\sigma^2(x) + A_\mu(x) A^\mu(x)) \quad (\text{B.10})$$

which is needed to prove that:

$$\begin{aligned} e^{qV} &= 1 + qV + \frac{q^2}{2} V^2 \\ &= 1 + q \left(2i (\theta\bar{\theta}) \sigma(x) + 2 (\theta\gamma^\mu\bar{\theta}) A_\mu(x) + \sqrt{2}i\theta^2 (\bar{\theta}\bar{\chi}(x)) - \sqrt{2}i\bar{\theta}^2 (\theta\chi(x)) + \theta^2\bar{\theta}^2 D(x) \right) \\ &\quad + q^2 \theta^2 \bar{\theta}^2 (\sigma^2(x) + A_\mu(x) A^\mu(x)) \end{aligned} \quad (\text{B.11})$$

The superfield multiplications (e.g. $Q^\dagger e^{qV} Q$) become extremely involved and will not be derived here. The results of the relevant superfield multiplications are simply stated in section 4.

C Chern-Simons Field Theory

C.1 Integrating Over Momentum for the Induced Abelian Chern-Simons Term

The integral to solve is:

$$[\text{Int}] = \int_{-\infty}^{\infty} \frac{d^3 k}{(2\pi)^3} \frac{1}{\left((p+k)^2 + m^2\right) (k^2 + m^2)} \quad (\text{C.1})$$

Using Feynman parameters [44]:

$$\begin{aligned} & \frac{1}{\left((p+k)^2 + m^2\right) (k^2 + m^2)} \\ &= \int_0^1 dx dy \delta(x+y-1) \frac{1}{\left[x \left((p+k)^2 + m^2\right) + y (k^2 + m^2)\right]^2} \end{aligned} \quad (\text{C.2})$$

where:

$$D \equiv x \left((p+k)^2 + m^2\right) + y (k^2 + m^2) \quad (\text{C.3})$$

Setting $x + y = 1$ gives:

$$\begin{aligned} D &= xp^2 + xk^2 + 2xpk + xm^2 + yk^2 + ym^2 \\ &= k^2 + xp^2 + 2xpk + m^2 \end{aligned} \quad (\text{C.4})$$

Defining $l \equiv k + xp$ gives:

$$k = l - xp \quad (\text{C.5})$$

$$\Rightarrow k^2 = l^2 + x^2 p^2 - 2xpl \quad (\text{C.6})$$

Inserting equation C.6 into equation C.4 gives:

$$\begin{aligned} D &= l^2 + x^2 p^2 - \cancel{2xpl} + xp^2 + \cancel{2xpl} - 2x^2 p^2 + m^2 \\ &= l^2 - x^2 p^2 + xp^2 + m^2 \end{aligned} \quad (\text{C.7})$$

Now define $\Delta \equiv x^2 p^2 - xp^2 - m^2$. Using this equation C.7 can be written:

$$D = l^2 - \Delta \quad (\text{C.8})$$

Plugging equation C.8 into equation C.2 gives:

$$[\text{Int}] = \int_{-\infty}^{\infty} \frac{d^3 l}{(2\pi)^3} \int_0^1 dx dy \delta(x + y - 1) \frac{1}{(l^2 - \Delta)^2} \quad (\text{C.9})$$

Next the Wick rotation $l^0 \rightarrow il_{0,E}, l_1 \rightarrow l_{1,E}, l_2 \rightarrow l_{2,E}$ is performed. The integral becomes:

$$[\text{Int}] = \frac{i}{(2\pi)^3} \int_{-\infty}^{\infty} d^3 l_E \int_0^1 dx dy \delta(x + y - 1) \frac{1}{(l_E^2 - \Delta)^2} \quad (\text{C.10})$$

Treating l_E like the radius of a sphere gives [44]:

$$\begin{aligned} \int_{-\infty}^{\infty} d^3 l_E &= \int dV = \int_0^{\infty} l_E^2 dl_E \int_0^{\pi} d\theta \int_0^{2\pi} d\phi \sin\theta \\ &= \int_0^{\infty} l_E^2 dl_E \int_0^{2\pi} d\phi [-\cos\theta]_0^{\pi} \\ &= \int_0^{\infty} l_E^2 dl_E \int_0^{2\pi} d\phi 2 \\ &= \int_0^{\infty} l_E^2 dl_E [2\phi]_0^{2\pi} \\ &= \int_0^{\infty} l_E^2 dl_E 4\pi \end{aligned} \quad (\text{C.11})$$

Using equation C.11 in gives:

$$\begin{aligned} [\text{Int}] &= \frac{i}{(2\pi)^3} 4\pi \int_0^{\infty} l_E^2 dl_E \int_0^1 dx dy \delta(x + y - 1) \frac{1}{(l_E^2 - \Delta)^2} \\ &= \frac{2i}{(2\pi)^2} \int_0^{\infty} l_E^2 dl_E \int_0^1 dx dy \delta(x + y - 1) \frac{1}{(l_E^2 - \Delta)^2} \end{aligned} \quad (\text{C.12})$$

Now, it is possible to prove that:

$$\int_0^{\infty} \frac{l_E^2}{(l_E^2 - \Delta)^2} = \frac{\pi}{i4\sqrt{\Delta}} \quad (\text{C.13})$$

Plugging equation C.13 into equation C.12 gives:

$$[\text{Int}] = \frac{1}{8\pi} \int_0^1 dx dy \delta(x+y-1) \frac{1}{\sqrt{\Delta}} \quad (\text{C.14})$$

Using $\Delta \equiv x^2 p^2 - x p^2 - m^2$, this becomes:

$$[\text{Int}] = \frac{1}{8\pi} \int_0^1 dx dy \delta(x+y-1) \frac{1}{\sqrt{x^2 p^2 - x p^2 - m^2}} \quad (\text{C.15})$$

Evaluating this integral gives [45]:

$$[\text{Int}] = \frac{1}{4\pi i} \frac{1}{|p|} \arcsin \left(\frac{|p|}{\sqrt{p^2 + 4m^2}} \right) \quad (\text{C.16})$$

C.2 Level Quantisation in Non-abelian Chern-Simons Gauge Theories

Non-abelian Chern-Simons theories are required to have integer level [88]. This arises as a requirement for gauge invariance of the non-abelian CS term in the action, and due to the fact that the winding number of the gauge transformations are integer valued.

An abelian transformations of a gauge field is given by:

$$A_\mu \rightarrow A_\mu - iU^\dagger \partial_\mu U \quad (\text{C.17})$$

where $U = U(x) \in U(1)$. U takes the general form:

$$U(x) = \exp(i\lambda(x)T) \quad (\text{C.18})$$

where $T \in \mathfrak{u}(1)$.

The non-abelian $U(n)$ transformation is given by [88]:

$$A_\mu \rightarrow U^\dagger A_\mu U - iU^\dagger \partial_\mu U \quad (A_\mu(x) = A_\mu^a(x)T^a) \quad (\text{C.19})$$

where $U = U(x) \in U(n)$. U takes the general form:

$$U(x) = \exp(i\lambda^a(x)T^a) \quad (\text{C.20})$$

where $T^a \in \mathfrak{u}(n)$.

The non-abelian Chern-Simons term is given as:

$$\frac{k}{4\pi} \int d^3x \epsilon^{\mu\nu\rho} \text{Tr} \left(A_\mu \partial_\nu A_\rho + i \frac{2}{3} A_\mu A_\nu A_\rho \right) \quad (\text{C.21})$$

The non-abelian gauge transformations act on the non-abelian Chern-Simons term as [88]:

$$\begin{aligned} S_{CS} &\rightarrow S'_{CS} \\ &= S_{CS} + i \frac{k}{4\pi} \int d^3x \epsilon^{\mu\nu\rho} \partial_\mu \text{Tr} \left(\partial_\nu U U^\dagger A_\rho \right) \\ &\quad + \frac{k}{12\pi} \int d^3x \epsilon^{\mu\nu\rho} \text{Tr} \left(U^\dagger \partial_\mu U U^\dagger \partial_\nu U U^\dagger \partial_\rho U \right) \end{aligned} \quad (\text{C.22})$$

The second term disappears as it is a total derivative. It is clear that the third term is exclusive to the non-abelian Chern-Simons term; such a term would not appear in the gauge transformation of the abelian Chern-Simons term. This term is proportional to the ‘winding number’, ω , of the gauge transformation $U(x)$ [88]:

$$\omega = \frac{1}{24\pi^2} \int d^3x \epsilon^{\mu\nu\rho} \text{Tr} \left(U^\dagger \partial_\mu U U^\dagger \partial_\nu U U^\dagger \partial_\rho U \right) \quad (\text{C.23})$$

This quantity is an integer. Using C.23, C.22 becomes [88]:

$$\begin{aligned} S_{CS} &\rightarrow S'_{CS} \\ &= S_{CS} + k2\pi\omega \end{aligned} \quad (\text{C.24})$$

In order for path integrals to be left invariant by this gauge transformation the second term must be a multiple of 2π , which restricts k to integer values.

D Angle of the (p, q) -brane and Preservation of Supersymmetry

The preservation of supersymmetry by the (p, q) -brane is reliant on a BPS condition being satisfied [89].

The condition is satisfied only if the charges of the branes are conserved at the NS5-D5- (p, q) junction and if the tensions of the branes are balanced at the junction [89].

This was originally considered for the junction of three (p, q) -strings, but was generalised to a junction of three 5-branes [89].

A Junction of Three (p, q) -strings

Take the charge at the end point of a D1-brane ('D-string') to be given by 1; then q coincident D-strings have charge q at one end. Similarly, take the charge at the end of a fundamental string ('F-string') to be 1; then p F-strings have charge p . In general a string has charge (p, q) . When an F-string ends on a D-string, analysis of the charges associated with the ends of D-strings and F-strings show that one side of the D-string remains a D-string but the other side must become a boundstate of the F and D-string [90]. The 'sides' are those lengths of the D-string separated by the junction point with the F-string. Denoting the charges of the F-string as $(1, 0)$ and the D-string as $(0, 1)$, the third boundstate string at the junction has charge $(1, 1)$.

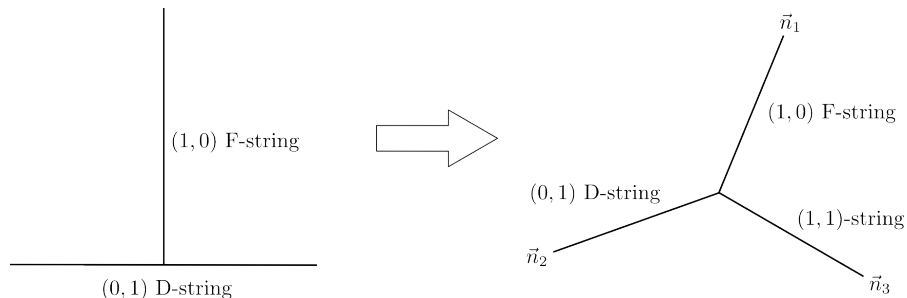

Figure 18: The Deformation at the Junction of an F-string and D-string

Imagine the D and F-strings as 'incoming' and the $(1, 1)$ -string as 'outgoing'. Therefore it makes sense that the $(1, 1)$ -string has charge equal to the sum of the charges of the other two strings. Assigning a sign of $+1$ to incoming charges and -1 for outgoing charges allows the conservation of charge to be written [90]:

$$\sum_i^3 p_i = \sum_i^3 q_i = 0 \quad (\text{D.1})$$

where $i = 1, 2, 3$ labels each of the three different strings. Such junctions (with conserved charges) saturate the BPS bound provided that the strings are oriented at specific angles [90, 91]. These angles ensure that the tensions of the strings are balanced [89, 90]. Assigning each string a tension T_i and a direction \vec{n}_i , the tensions must satisfy:

$$\sum_i^3 T_i \vec{n}_i = 0 \tag{D.2}$$

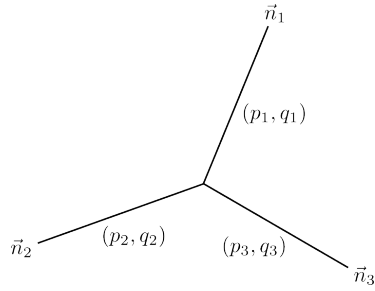

Figure 19: The Deformation at the Junction of (p, q) -branes.

References

- [1] B. Zwiebach. *A First Course in String Theory*. Cambridge University Press, 2004.
- [2] O. Aharony. Ir duality in $d=3$ $n=2$ supersymmetric $usp(2nc)$ and $u(nc)$ gauge theories. *Physics Letters B*, 404(1):71–76, 1997.
- [3] A. Giveon and D. Kutasov. Seiberg duality in chern-simons theory. *Nuclear physics B*, 812(1):1–11, 2009.
- [4] S. Khan and R. Tatar. Flows between dualities for 3d chern-simons theories. *arXiv preprint arXiv:1307.4640*, 2013.
- [5] L. McAllister and F. Tanedo. Lectures on string theory, March 2010.
- [6] T. Ortín. *Gravity and Strings (Cambridge Monographs on Mathematical Physics)*. Cambridge University Press, 2007.
- [7] T. Mohaupt. Liverpool lectures on string theory, the free bosonic string, 2008.
- [8] J. Polchinski. *String theory. Vol. 1: An Introduction to the Bosonic String. Vol. 2: Superstring Theory and Beyond*, volume 402. 1998.
- [9] S. Catterall and E. Mottola. The conformal mode in 2d simplicial gravity. *Physics Letters B*, 467(1):29–39, 1999.
- [10] D. McMahon. *String Theory Demystified*. McGraw-Hill Education, 2008.
- [11] Katrin Becker, Melanie Becker, and John H Schwarz. *String Theory and M-theory: A Modern Introduction*. Cambridge University Press, 2006.
- [12] D. Tong. String theory: University of cambridge part iii mathematical tripos. *arXiv preprint arXiv:0908.0333*, 2009.
- [13] R. Blumenhagen and E. Plauschinn. *Introduction to Conformal Field Theory: With Applications to String Theory*. Lecture Notes in Physics. Springer Berlin Heidelberg, 2009.
- [14] T. Weigand. Introduction to string theory, 2010.
- [15] M. Gasperini. *Elements of String Cosmology*. Cambridge University Press, 2007.
- [16] P. Van Nieuwenhuizen. Supergravity. *Physics Reports*, 68(4):189–398, 1981.
- [17] R. Blumenhagen, D. Lüüst, and S. Theisen. *Basic Concepts of String Theory*. Springer Science & Business Media, 2012.
- [18] L. Görlich. $N=1$ and non-supersymmetric open string theories in six and four space-time dimensions. *arXiv preprint hep-th/0401040*, 2004.

- [19] D.G. Moore. *The Landscape of Free Fermionic Gauge Models*. PhD thesis, 2014.
- [20] M. B. Green, J. H. Schwarz, and E. Witten. *Superstring Theory: Volume 2, Loop Amplitudes, Anomalies and Phenomenology*. Cambridge university press, 2012.
- [21] F. W. Hehl, P. von der Heyde, G. D. Kerlick, and J. M. Nester. General relativity with spin and torsion: Foundations and prospects. *Rev. Mod. Phys.*, 48:393–416, Jul 1976.
- [22] N. J. Poplawski. Spacetime and fields. *arXiv preprint arXiv:0911.0334*, 2009.
- [23] L. Baulieu, P. Di Francesco, M. Douglas, V. Kazakov, M. Picco, and P. Windey. *Strings, Branes and Dualities*, volume 520. Springer Science & Business Media, 2012.
- [24] P. West. *Introduction to Strings and Branes*. Cambridge University Press, 2012.
- [25] G. L. Kane. *Perspectives on Supersymmetry II*, volume 2. World Scientific, 2010.
- [26] K. Wray. An introduction to string theory. *Notes*, 2011.
- [27] K. S. Choi and J. E. Kim. *Quarks and Leptons from Orbifolded Superstring*, volume 696. Springer, 2006.
- [28] S. Gukov and J. Sparks. M-theory on spin (7) manifolds. *Nuclear Physics B*, 625(1):3–69, 2002.
- [29] E. M. Babalic and C. I. Lazaroiu. Foliated eight-manifolds for m-theory compactification. *Journal of High Energy Physics*, 2015(1):1–60, 2015.
- [30] B. S. Acharya, J. M. Figueroa-O’Farrill, B. Spence, and M. O’Loughlin. Euclidean d-branes and higher-dimensional gauge theory. *Nuclear Physics B*, 514(3):583–602, 1998.
- [31] L. S. Brown. *Quantum Field Theory*. Cambridge University Press, 1994.
- [32] S.S. Gubser and J.D. Lykken. *Strings, Branes and Extra Dimensions: TASI 2001, Boulder, Colorado, USA, 4-29 June 2001*. World Scientific, 2004.
- [33] M. Benna, I. Klebanov, T. Klose, and M. Smedbäck. Superconformal chern-simons theories and ads4/cft3 correspondence. *Journal of High Energy Physics*, 2008(09):072, 2008.
- [34] K. Intriligator and N. Seiberg. Aspects of 3d $\mathcal{N} = 2$ chern-simons-matter theories. *Journal of High Energy Physics*, 2013(7):1–64, 2013.
- [35] M. Aganagic and A. Karch. Calabi-yau mirror symmetry as a gauge theory duality. *Classical and Quantum Gravity*, 17(5):919, 2000.

- [36] H. J. W. Müller-Kirsten and A. Wiedemann. *Introduction to Supersymmetry*, volume 80. World Scientific, 2010.
- [37] O. Bergman, A. Hanany, A. Karch, and B. Kol. Branes and supersymmetry breaking in three dimensional gauge theories. *Journal of High Energy Physics*, 1999(10):036, 1999.
- [38] A. Giveon and D. Kutasov. Brane dynamics and gauge theory. *Reviews of Modern Physics*, 71(4):983, 1999.
- [39] D. Kutasov and A. Schwimmer. On duality in supersymmetric yang-mills theory. *Physics Letters B*, 354(3):315–321, 1995.
- [40] D. Kutasov, A. Schwimmer, and N. Seiberg. Chiral rings, singularity theory and electric-magnetic duality. *Nuclear Physics B*, 459(3):455–496, 1996.
- [41] V. Niarchos. Seiberg duality in chern-simons theories with fundamental and adjoint matter. *Journal of High Energy Physics*, 2008(11):001, 2008.
- [42] V. Niarchos. R-charges, chiral rings and rg flows in supersymmetric chern-simons-matter theories. *Journal of High Energy Physics*, 2009(05):054, 2009.
- [43] S. Ojima. Derivation of gauge and gravitational induced chern-simons terms in three dimensions. *Progress of theoretical physics*, 81(2):512–522, 1989.
- [44] M. E. Peskin and D. V. Schroeder. *An Introduction to Quantum Field Theory*. Westview, 1995.
- [45] G. V. Dunne. Aspects of chern-simons theory. In *Aspects topologiques de la physique en basse dimension. Topological aspects of low dimensional systems*, pages 177–263. Springer, 1999.
- [46] M. Haack, B. Kors, and D. Lust. Recent developments in string theory: From perturbative dualities to m-theory. *arXiv preprint hep-th/9904033*, 1999.
- [47] J. Casalderrey-Solana, H. Liu, D. Mateos, K. Rajagopal, and U. A. Wiedemann. Gauge/string duality, hot qcd and heavy ion collisions. *arXiv preprint arXiv:1101.0618*, 2011.
- [48] A. Hanany and E. Witten. Type iib superstrings, bps monopoles, and three-dimensional gauge dynamics. *Nuclear Physics B*, 492(1):152–190, 1997.
- [49] L. E. Ibáñez and A. M. Uranga. *String Theory and Particle Physics: An Introduction to String Phenomenology*. Cambridge University Press, 2012.
- [50] I. Brunner. On the interplay between string and field theory. Technical report, SIS-2000-392, 1998.

- [51] D. Z. Freedman and S. S. Pufu. The holography of f-maximization. *Journal of High Energy Physics*, 2014(3):1–41, 2014.
- [52] C. Closset and R. Argurio. Studies of fractional d-branes in the gauge/gravity correspondence & flavored chern-simons quivers for m2-branes. 2010.
- [53] M. Shifman. Advanced topics in quantum field theory: A lecture course. *Contemporary Physics*, 53(5):446–447, 2012.
- [54] José LF Barbón. Rotated branes and n= 1 duality. *Physics Letters B*, 402(1):59–63, 1997.
- [55] O. Aharony and A. Hanany. Branes, superpotentials and superconformal fixed points. *Nuclear Physics B*, 504(1):239–271, 1997.
- [56] E. Witten. Solutions of four-dimensional field theories via m-theory. *Nuclear Physics B*, 500(1):3–42, 1997.
- [57] K. Intriligator and N. Seiberg. Mirror symmetry in three dimensional gauge theories. *Physics Letters B*, 387(3):513–519, 1996.
- [58] T. Kitao, K. Ohta, and N. Ohta. Three-dimensional gauge dynamics from brane configurations with the (p, q)-fivebrane. *Nuclear Physics B*, 539(1):79–106, 1999.
- [59] S. A. Cherkis, C. O’Hara, and C. Sämann. Super yang-mills theory with impurity walls and instanton moduli spaces. *Physical Review D*, 83(12):126009, 2011.
- [60] J. M. Figueroa and O. Farrill. Electromagnetic duality for children, 1998.
- [61] E. Castellani. Dualities and intertheoretic relations. In *EPSA Philosophical Issues in the Sciences*, pages 9–19. Springer, 2010.
- [62] K. Hashimoto. *D-brane: Superstrings and New Perspective of Our World*. Springer Science & Business Media, 2012.
- [63] P. A. M. Dirac. Quantised singularities in the electromagnetic field. In *Proceedings of the Royal Society of London A: Mathematical, Physical and Engineering Sciences*, volume 133, pages 60–72. The Royal Society, 1931.
- [64] K. M. Ellis. Magnetic monopoles: Quantization and quasiparticles. 2013.
- [65] C. Montonen and D. Olive. Magnetic monopoles as gauge particles? *Physics Letters B*, 72(1):117–120, 1977.
- [66] P. Di Vecchia. Duality in n= 2, 4 supersymmetric gauge theories. *arXiv preprint hep-th/9803026*, 43:293, 1998.
- [67] E. Witten. Duality, spacetime and quantum mechanics. *Physics Today*, 50(5):28–33, 1997.

- [68] J. S. Song. Theory of magnetic monopoles and electric-magnetic duality: A prelude to s-duality. *J. Undergrad. Sci.*, 3:47–55, 1996.
- [69] P. M. Sutcliffe. Bps monopoles. *International Journal of Modern Physics A*, 12(26):4663–4705, 1997.
- [70] A. d’Adda, R. Horsley, and P. Di Vecchia. Supersymmetric magnetic monopoles and dyons. *Physics Letters B*, 76(3):298–302, 1978.
- [71] H. Dai. N= 2 supersymmetric yang-mills theory. 2005.
- [72] H. Osborn. Topological charges for n= 4 supersymmetric gauge theories and monopoles of spin 1. *Physics Letters B*, 83(3):321–326, 1979.
- [73] N. Seiberg. Electric-magnetic duality in supersymmetric non-abelian gauge theories. *Nuclear Physics B*, 435(1):129–146, 1995.
- [74] F. Tanedo. Notes on seibergology. 2013.
- [75] J. A. Harvey. Tasi 2003 lectures on anomalies. *arXiv preprint hep-th/0509097*, 2005.
- [76] T. P. Cheng and L. F. Li. *Gauge Theory of Elementary Particle Physics*. Clarendon press Oxford, 1984.
- [77] G. ’t Hooft. Naturalness, chiral symmetry, and spontaneous chiral symmetry breaking. *Recent developments in gauge theories. Proceedings of the NATO Advanced Study Institute on recent developments in gauge theories, held in Cargèse, Corsica, August 26-September 8, 1979*, pages 135–157, 1980.
- [78] C. Csáki and H. Murayama. ’t hooft anomaly matching for discrete symmetries. *arXiv preprint hep-th/9805053*, 1998.
- [79] S. Abel. Anomalies, 2014.
- [80] C. P. Burgess and G. D. Moore. *The Standard Model: A Primer*. Cambridge University Press, 2006.
- [81] J. Terning. *Modern Supersymmetry: Dynamics and Duality*. Oxford University Press, 2006.
- [82] O. Aharony, A. Hanany, K. Intriligator, N. Seiberg, and M. J. Strassler. Aspects of n= 2 supersymmetric gauge theories in three dimensions. *Nuclear Physics B*, 499(1):67–99, 1997.
- [83] F. Benini, C. Closset, and S. Cremonesi. Comments on 3d seiberg-like dualities. *Journal of High Energy Physics*, 2011(10):1–40, 2011.

- [84] B. Willett and I. Yaakov. N= 2 dualities and z extremization in three dimensions. *arXiv preprint arXiv:1104.0487*, 2011.
- [85] D. Bashkirov. Aharony duality and monopole operators in three dimensions. *arXiv preprint arXiv:1106.4110*, 2011.
- [86] H. Kim and J. Park. Aharony dualities for 3d theories with adjoint matter. *Journal of High Energy Physics*, 2013(6):1–30, 2013.
- [87] A. Amariti and C. Klare. Chern-simons and rg flows: Contact with dualities. *Journal of High Energy Physics*, 2014(8):1–26, 2014.
- [88] J. K. Pachos. *Introduction to Topological Quantum Computation*. Cambridge University Press, 2012.
- [89] Y. Matsuo and K. Okuyama. Bps condition of string junction from m theory. *Physics Letters B*, 426(3):294–296, 1998.
- [90] K. Dasgupta and S. Mukhi. Bps nature of 3-string junctions. *Physics Letters B*, 423(3):261–264, 1998.
- [91] J. H. Schwarz. Lectures on superstring and m theory dualities. *Nuclear Physics B-Proceedings Supplements*, 55(2):1–32, 1997.