

# OPTIMIZATION OF A SHORT FARADAY CUP FOR LOW-ENERGY IONS USING NUMERICAL SIMULATIONS\*

A. Sosa<sup>†</sup>, E. Bravin, E. D. Cantero, CERN, Geneva, Switzerland  
C. P. Welsch, Cockcroft Institute, Warrington, Cheshire,  
The University of Liverpool, Liverpool, United Kingdom

## Abstract

ISOLDE, the heavy-ion facility at CERN is undergoing a major upgrade with the installation of a superconducting LINAC that will allow post-acceleration of ion beams up to 10 MeV/u. In this framework, customized beam diagnostics are being developed in order to fulfil the design requirements as well as to fit in the compact diagnostic boxes foreseen. The main detector of this system is a compact Faraday cup that will measure beam intensities in the range of 1 pA to 1 nA. In this contribution, simulation results of electrostatic fields and particle tracking are detailed for different Faraday cup prototypes taking into account the energy spectrum and angle of emission of the ion-induced secondary electrons.

## INTRODUCTION

The High Intensity and Energy (HIE) upgrade of the Isotope On-Line DEvice (ISOLDE) facility at CERN aims to increase the energy and intensity of the radioactive ion beams currently available on site. From the beam energy standpoint, an increase from the present 3 MeV/u to 10 MeV/u is foreseen for ions with a mass-to-charge ratio of  $A/Q \leq 4.5$ . The present room-temperature LINAC (known as REX) will be replaced with a superconducting LINAC with up to six cryomodules containing a total of 32 Nb-sputtered quarter-wave resonators [1]. All beam diagnostic devices will be installed in purpose-built diagnostic boxes, located in every inter-cryomodule region and along designated points in the High Energy Beam Transfer lines (HEBTs). A total of 15 diagnostic boxes (seven in the LINAC and eight in the HEBT) are required for the complete upgrade. The number and type of diagnostic devices in each box is different depending on the location in the accelerator. Beam intensity, transverse beam profile and beam position can be measured at each diagnostic box location. Other devices available in some boxes include a silicon detector, sets of collimators, beam attenuators and stripping foils.

## COMPACT FARADAY CUP

Faraday cups are well known devices with a simple and reliable technique for measuring absolute beam intensities, but optimizing a Faraday cup for a specific set of beam parameters, especially with low-intensity ion

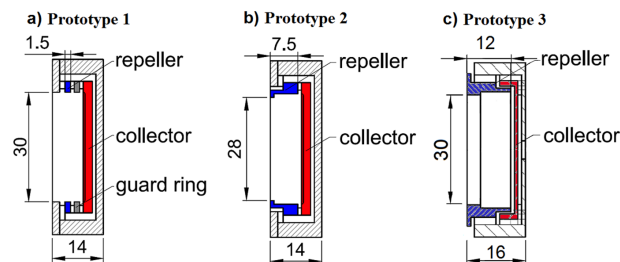

Figure 1: Schematic of the different Faraday cup prototypes developed for HIE-ISOLDE.

beams remains challenging [2]. The Faraday cup used in the current REX-ISOLDE LINAC has been redesigned into a much shorter version in order to fit in the short (58 mm long) diagnostic boxes of HIE-ISOLDE. The Faraday cup to be used in HIE-ISOLDE should be 30 mm in diameter to cover the full beam aperture (max. beam sizes in HIE-ISOLDE are  $1\sigma=5$  mm). The initial prototype (Prototype 1), shown in Fig. 1(a), is just a rescale of the original design and has a repeller ring and ground ring measuring 1.5 mm in length, and a 2.5 mm thick collector electrode, the whole enclosed in a metallic housing. The collector electrode and repeller ring of the first prototype are made of stainless steel (AISI 316L [3]), the body is made of aluminium (6082) and the insulators are made of VESPEL<sup>®</sup> SP-1 [4].

## ELECTROSTATIC SIMULATIONS

Numerical simulations have been done in order to assess the design of the cups, analysing the electrostatic potential distribution and the secondary electron emission. CST Particle Studio [5] was used to study the electrostatic fields and track secondary electrons in these cups. When the repeller ring is biased at a given voltage, the electrostatic potential in the central axis of the Faraday cup varies according to the length and inner diameter of the repeller ring. The electrostatic potential is a maximum on the surface of the repeller ring and has a minimum value in the centre of the cup, corresponding to the beam axis.

In Fig. 2 the potential distribution for the initial HIE-ISOLDE Faraday cup prototype biased at -60 V is shown. The compact geometry of the FC results in only -5 V in the centre when the repeller ring is biased to a voltage of -60 V. As this repeller voltage is insufficient to contain

\*This project has received funding from the European Union's Seventh Framework Programme for research, technological development and demonstration under grant agreement no 264330.

<sup>†</sup> alejandro.garcia.sosa@cern.ch

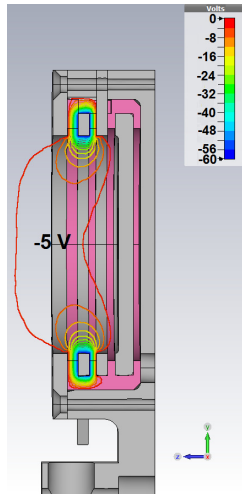

Figure 2: Electrostatic potential distribution for the Prototype 1 Faraday cup biased at -60 V.

secondary electron emission, a modification of the existing Faraday cup was done to test the effect of a longer repeller ring, resulting in Prototype 2.

Prototype 2 is composed of a 7.5 mm repeller ring, with the aim of increasing the potential in the centre of the cup, and a reduced aperture of 28 mm at the cost of measuring a smaller maximum beam size. Its potential distribution biased at -60 V (Fig. 3) shows an increased potential in the cup's centre of -22 V. In this cup the guard ring was removed because of the limited space available.

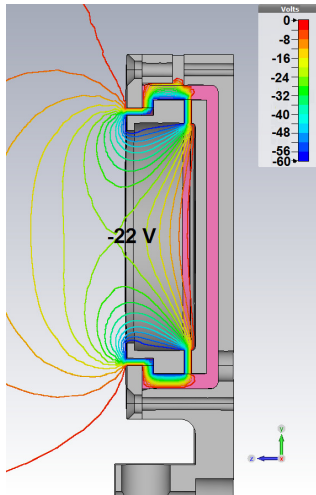

Figure 3: Electrostatic potential distribution for the Prototype 2 Faraday cup biased at -60V.

Taking advantage of the maximum length available for the Faraday cup inside the diagnostics box (16 mm) and going in the same direction of increasing the length of the repeller ring, as well as redesigning and optimizing all other parts, Prototype 3 was built.

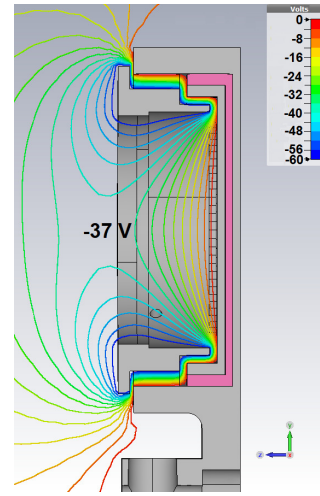

Figure 4: Electrostatic potential distribution for the Prototype 3 Faraday cup biased at -60 V.

Prototype 3 has a 12 mm repeller ring and covers the full 30 mm beam aperture. The thickness of the collector electrode, insulator and back of the FC body is 1 mm. As shown in Fig. 4, biasing the repeller ring at -60 V the potential barrier in this design is -37 V, well beyond the typical energy peak of secondary electron emission ( $<20$  eV) [6].

## PARTICLE TRACKING & LOSS PROBABILITY

Particle tracking simulations using CST were run to study the charge loss probability of the different Faraday cup prototypes when emitting electrons at different emission energies and angles from a beam-sized surface centred on the collector electrode. Loss probability was defined as the percentage of secondary electrons escaping the collector electrode over the total amount of secondary electrons emitted from the collector surface. In all simulations,  $10^4$  electrons were emitted simultaneously from a circular surface source of 3 mm in diameter facing the aperture of the Faraday cup, as the critical area for the escape of electrons is precisely the centre of the cup. It is not possible to simulate ion-induced electron emission, hence the use of the electron source in the cup.

The loss probability values for each Faraday cup prototype were obtained by counting the number of electrons that do not return to the collector electrode and dividing this by the total number of electrons emitted. This was performed for many different configurations, sweeping the electron emission energy (0 to 500 eV) and the repeller ring voltage (0 to -500 V) for several electron emission angle cones ( $0^\circ$ ,  $45^\circ$  and  $90^\circ$ ) relative to the beam axis. Electrons are emitted in random angles within that cone, but not necessarily isotropically. Very few previous studies exist about ion-induced electron emission for this particular projectile-target combination and energy range. However,

similar studies suggest that the angular distribution of the emitted electrons follows a cosine law [7].

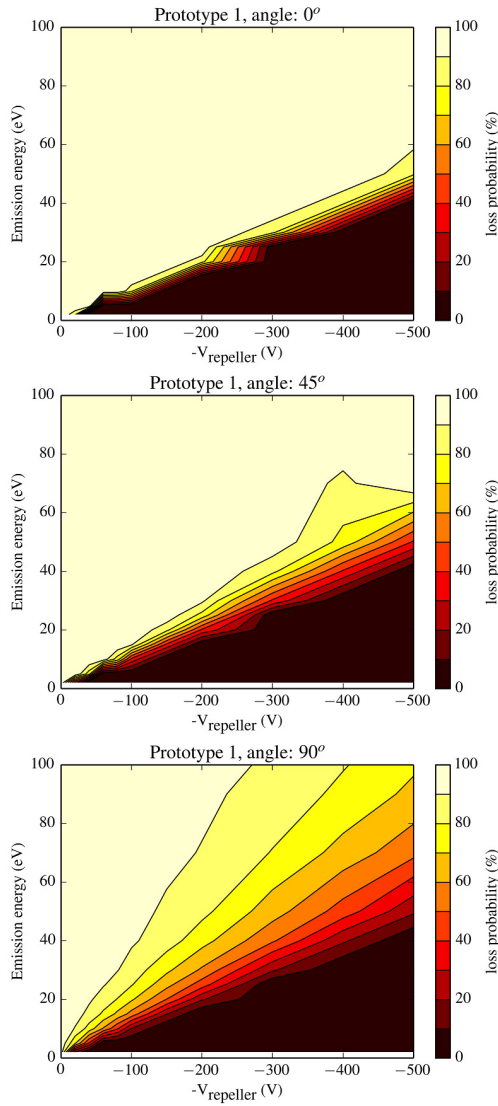

Figure 5: Loss probability of Prototype 1 at different emission energies, repeller ring voltages and maximum emission angle cones of 0°, 45° and 90°.

## SIMULATION RESULTS

### Prototype 1

In the case of Prototype 1 (see Fig. 5), the loss probability is 100% at an emission energy of 20 eV and 0° emission angle. Even biasing the repeller ring at voltages up to -100 V the loss probability only decreases to about 80% in the case of an emission angle cone of 90°. This would lead to false beam intensity measurements in the FC, making the device inaccurate.

### Prototype 2

The design of Prototype 2 greatly improves the retention of electrons in the collector. As shown in Fig. 6, all elec-

trons emitted at 20 eV would be retained by the cup at voltages beyond -100 V for all emission angles. In the case of a 90° emission angle, distortions in the general behaviour may be due to secondary electron emission in other metal parts of the FC such as the repeller ring.

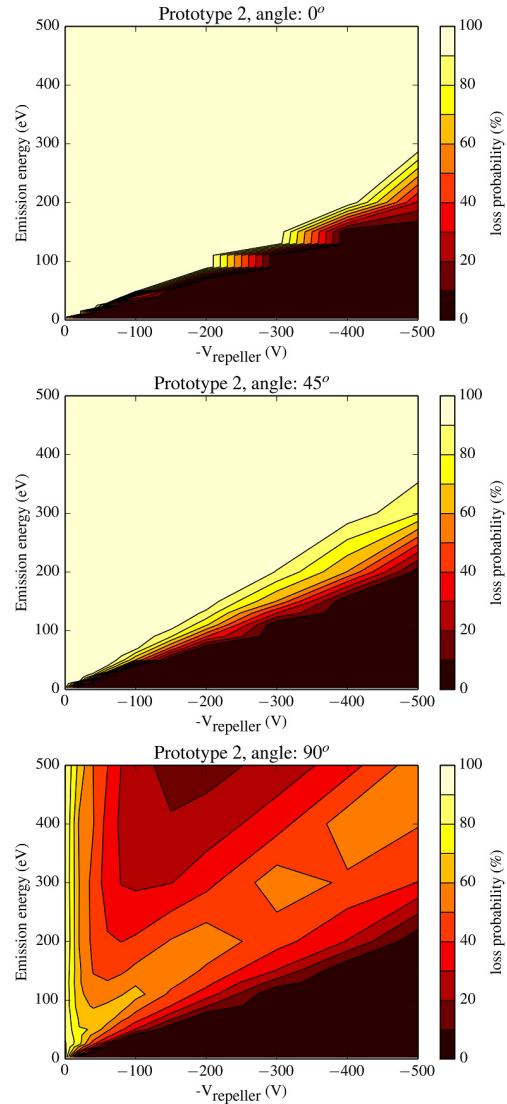

Figure 6: Loss probability of Prototype 2 at different emission energies, repeller ring voltages and maximum emission angles of 0°, 45° and 90°.

### Prototype 3

The simulation results for Prototype 3, shown in Fig. 7, indicate a 0% loss probability at lower voltages compared to Prototype 2. The geometry of Prototype 3 also shows 0% loss probability at -500 V in the case of electrons with an emission energy up to 300 eV.

## CONCLUSIONS & OUTLOOK

A short Faraday cup has been developed at CERN to measure low-energy ion beam intensities and, when used

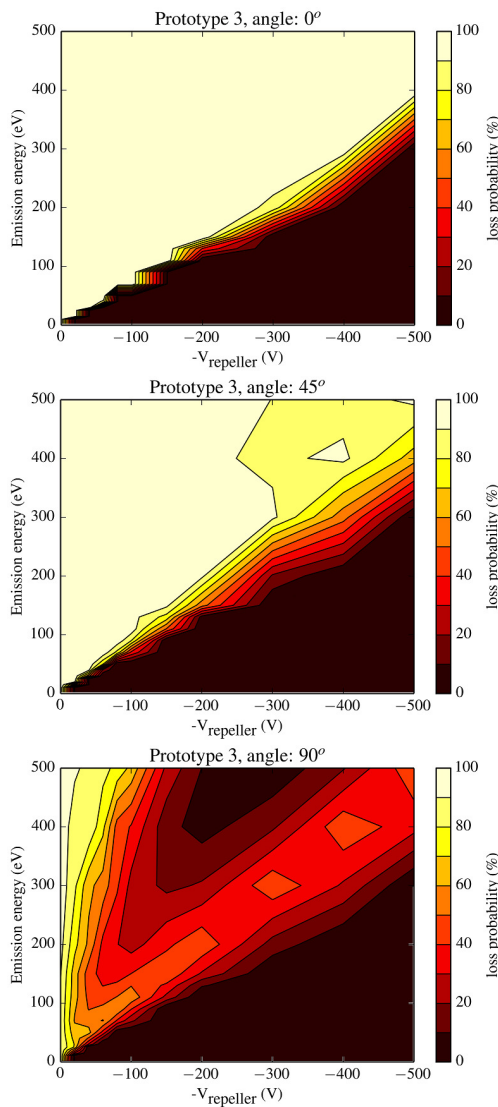

Figure 7: Loss probability of Prototype 3 at different emission energies, repeller ring voltages and maximum emission angles of  $0^\circ$ ,  $45^\circ$  and  $90^\circ$ .

together with the slit scanner, the transverse beam profile and position. This is the main beam instrumentation system for the HIE-ISOLDE project. An extension of the repeller ring in the longitudinal direction has been shown to eliminate the loss of secondary electrons from the Faraday cup even for relatively low bias voltages. All prototypes discussed in this contribution have been built and tested using ion beams with a mass-to-charge ratio  $A/q \leq 4.5$ . Further work on estimating the electron yield and their energy spectrum for this particular target-projectile combination is in progress.

## ACKNOWLEDGEMENTS

The authors would like to thank the technical staff from the beam instrumentation group at CERN for their support and help throughout this development project.

## REFERENCES

- [1] Sosa, A., Fraser, M. A., Kadi, Y., Welsch, C. P., Galipienzo, J., Bravin, E., ... & Larman, A. (2012, May). Beam instrumentation for the HIE Isolde linac at CERN. In Conf. Proc. (Vol. 1205201, No. CERN-ATS-2012-091, p. MOPPR048).
- [2] Harasimowicz, J., Welsch, C. P., Cosentino, L., Pappalardo, A., & Finocchiaro, P. (2012). Beam diagnostics for low energy beams. *Physical Review Special Topics-Accelerators and Beams*, 15(12), 122801.
- [3] American Iron and Steel Institute: <http://www.steel.org/>
- [4] Vespel parts and shapes, DUPONT: <http://www.dupont.com/products-and-services/plastics-polymers-resins/parts-shapes/brands/vespel-polyimide.html>
- [5] CST Particle Studio, <http://www.cst.com/Content/Products/PS/Overview.aspx>
- [6] Hasselkamp, D., Hippler, S., & Scharmann, A. (1986). Ion-induced secondary electron spectra from clean metal surfaces. *Nuclear Instruments and Methods in Physics Research Section B: Beam Interactions with Materials and Atoms*, 18(1), 561-565.
- [7] Hasselkamp, D. (1992). Kinetic electron emission from solid surfaces under ion bombardment. In *Particle Induced Electron Emission II* (pp. 1-95). Springer Berlin Heidelberg.