

**Armin Setayeshgar**

# **Principles of Mechanical Design in Overhead Transmission Lines**

**School of Electrical Engineering**

Master's Thesis submitted in partial fulfillment of the requirement for the degree of  
Master of Science and Technology.  
Espoo

**Thesis supervisor:**

Prof. Matti Lehtonen

**Thesis instructor:**

Prof. Matti Lehtonen



Aalto University School of Electrical Engineering Master's Programme in Electrical Engineering		ABSTRACT OF THE MASTER'S THESIS
Author: Armin Setayeshgar		
Title: Principles of Mechanical Design in Overhead Transmission Lines		
Number of pages: 8+64	Date: 03-10-2016	Language: English
Professorship: Power Systems		Code: S-18
Supervisor: Prof. Matti Lehtonen		
Instructors: Prof. Matti Lehtonen		
<p>Abstract:</p> <p>Technical infrastructures are of significant importance for a modern society to develop continuously, and dependence of society to electric power is ever-increasing. Power supply is also a must for economic growth and life convenience, and both industry and households have confidence in proper functionality of power network. Interruption in the power system due to technical faults, adverse weather and operational problems may result in irreparable consequences.</p> <p>Electricity, through Transformers and Transmission Lines, flows from Power Plants to Substations and Distribution System, and then to consumers .The Power and Distribution System is highly interconnected, which means that the Transmission Grid functions as one entity.</p> <p>This master thesis reviews the principles of mechanical design in Transmission Lines. Overhead Transmission Lines are expected to withstand climatic conditions and other outside disturbances. The applied forces must be tolerated mechanically by structural components of Transmission Line. Transmission Line must not fail in the hardest climatic situations. This fact obliges engineers to anticipate worst loading conditions, and select the best design in order to be confident of consistency and stability of operation in the Line.</p>		
Keywords: Transmission Lines, Load, Wind, Tension, Conductor, Steel Structure		

## Preface

This thesis is submitted to fulfill the requirements for Master's Degree in Power System and High Voltage Engineering in Aalto University, School of Electrical Engineering.

I would like to express my gratitude to Prof. Matti Lehtonen, for giving the opportunity to do this Master's thesis and his assistance, support, encouragement and guidance with regarding to the thesis.

I am also grateful to all my colleagues and friends, who provided me valuable information for my work and contributed to the friendly atmosphere in the office.

I am greatly indebted to my parents and my brother for their support and patience, may God bless my mother who always motivated me to pursue my educations. Last but certainly not the least, special thanks to Sassan Iraj, and Hamid Shariatmadari for their continuous support and never ending activation.

Otaniemi, Espoo October 2016

Armin Setayeshgar

# Contents

<b>ABSTRACT</b> .....	<b>ii</b>
<b>Preface</b> .....	<b>iii</b>
<b>Contents</b> .....	<b>iv</b>
<b>Symbols and Abbreviations</b> .....	<b>vi</b>
<b>List of figures</b> .....	<b>vii</b>
<b>1. Introduction</b> .....	<b>1</b>
1.1. Background.....	1
1.2. Purpose and Work scope.....	1
<b>2. Main Components of Overhead Transmission Line</b> .....	<b>3</b>
2.1. Conductor and Shieldwire .....	3
2.1.1 High Temperature - Low Sag Conductor.....	5
2.2. Steel Structure .....	6
2.3. Insulator.....	8
2.4. Hardware and Fittings.....	9
2.5. Foundation and Grounding System.....	9
<b>3. General Design Criteria</b> .....	<b>12</b>
3.1. Methodology.....	12
3.2. Reliability.....	12
3.3. Climatic Load – Strength Requirement.....	13
3.4. Considerations in Finland .....	15
<b>4. Mechanical Calculation Principles</b> .....	<b>18</b>
4.1. Conductor Sag and Tension.....	18
4.1.1 Thermal Elongation, Stress Behavior .....	21
4.1.2 Aging Effect, Behavior of Layered Conductor.....	23
4.1.3 Ruling Span, Sag-Tension Chart Determination.....	24
4.1.4 Wind and Ice Load on Conductor .....	34
4.2. Load on Support.....	38

4.2.1. Application, Configurations and Material of Structures.....	38
4.2.2. Types of Loading and Strength of Components.....	41
4.2.3. Transverse, Longitudinal and Vertical Forces .....	46
4.2.4. Plan and Profile, Sag-Template and Tower Spotting.....	50
4.2.5. Uplifting and Galloping.....	53
4.2.6 Unbalanced Longitudinal Load and Reasons of Failure .....	56
<b>5. Conclusion .....</b>	<b>61</b>
<b>References .....</b>	<b>62</b>

## Symbols and Abbreviations

AC	Alternating Current
ACCC	Aluminum Conductor Composite Core
ACSS	Aluminum Conductor, Steel Supported
ACSR	Aluminum Conductor Steel-Reinforced
ACSR/AW	Aluminum Conductor Steel Reinforced/Aluminum Clad Steel reinforced
ASTM	American Society for Testing and Materials
EN	European Standard
IEC	International Electro- technical Commission
OHGW	Overhead Ground Wires
PI	Point of Intersection
RS	Ruling span
RSL	Residual Static Load
$a_T$	Coefficient of Conductor Linear Thermal Expansion
$\sigma$	Conductor Stress
$\epsilon\sigma$	Conductor Strain
$\epsilon_C$	Conductor Plastic deformation
$\theta$	Transmission Line Angle
A	Conductor Cross-sectional area
E	Conductor Modulus of elasticity
H	Horizontal tension of Conductor
l	Length of Span
L	Conductor Length under no stress
$L\sigma$	Conductor Length under stress
$L_T$	Conductor Length at temperature T
$^{\circ}\text{C}$	Degrees Celsius
S	Conductor Sag
$V_w$	Vertical Load
$W_h$	Transverse load
W	Conductor unit Weight
$W_i$	Ice Unit Weight per Conductor unit length
$W_t$	Total Conduct unit Weight influenced by ice and wind
$W_w$	Wind Force per Conductor unit length

## List of figures

Figure 2.1	ACSR Conductor Type
Figure 2.2	ACCC and ACSS Conductor Types
Figure 2.3	Typical Lattice Steel Structures
Figure 2.4	Porcelain and Composite Insulators
Figure 2.5	Execution of Foundation - 1
Figure 2.6	Execution of Foundation - 2
Figure 4.1	Same Level Suspended Conductor
Figure 4.2	Parabolic Sag Curve
Figure 4.3	Leveled Span
Figure 4.4	Inclined Span
Figure 4.5	Sag in Inclined Span
Figure 4.6	Conductor Stress-Strain Relationship
Figure 4.7	Line Section for Ruling Span Example
Figure 4.8	Sag Comparison in Cold and Hot Conditions
Figure 4.9	Ice on Conductor
Figure 4.10	Effect of Wind and Ice on Conductor
Figure 4.11	Sag-Tension Envelope
Figure 4.12	Line Angel Bisected by Tension Tower
Figure 4.13	Dead end Structure - One sided stringing
Figure 4.14	Heavily Ice-Loaded Tower
Figure 4.15	Under Service Tower Failure
Figure 4.16	Weight Span Illustration

Figure 4.17	Weigh and Wind ( V and H ) Spans
Figure 4.18	Tower Spotting Sample
Figure 4.19	Cold-Curve Check for Uplift
Figure 4.20	Transmission Line Section Terminated by Tension Tower
Figure 4.21	Tower failure caused by unbalanced Load
Figure 4.22	Tower Failure caused by Harsh Weather Condition - 1
Figure 4.23	Tower Failure caused by Harsh Weather Condition - 2



*Page left intentionally*

# 1. Introduction

## 1.1. Background

Overhead Transmission Line transfers electrical energy from generating points to power substations located around demand centers. Transmission lines, while they are interconnected, create transmission networks and combination of power plants, substations and transmission and distribution network is defined as power grid.

The Network consists of two level infrastructures, Transmission and Distribution systems. Distribution and Transmission system were usually ruled by the same organization. Nowadays, many countries have separated the regulation of the electricity transmission from distribution business, which has the role of delivering the electricity to the homes.

Substations are Interfaces among Transmission and Distribution system. In Substations, there are different rates of transformers, which reduce voltages upper transmission to the lower distribution system voltages.

Three phase alternating current (AC) is generated by power plants, meaning that three conductor phases coming out from the power plant towards transmission lines. Conductors with large cross sectional area are installed on transmission structure and carry the electric power. On the peak of the structure, there is also a smaller wire, called a shield wire. The shield wire, which, might have fiber optic inside, is designed to protect the Transmission Line from lightning stroke.

## 1.2. Purpose and Work scope

Outages of Transmission Lines are similar to a dam, cause to force electricity rush into near Lines. In case that adjacent transmission lines are not able to transfer extra power flow, relay and protective devices might switch off the Lines, in order to prevent or limit the damage. Large overload may eventuate to cascading outages and even blackouts. Several failures in same location may rapidly affect the whole system and cause a wide scale

blackout. Though happening rarely, important areas need sufficient capacity backup Transmission Lines for reliability of Transmission System.

This master thesis reviews the principles of mechanical design in Transmission Lines. Transmission Lines are expected to withstand climatic conditions and other outside disturbances. The applied forces must be tolerated mechanically by structural components of Transmission Line. Transmission Line must not fail in the hardest climatic situations. This fact obliges engineers to anticipate worst loading conditions, and select the best design in order to be confident of consistency and stability of operation in the Line.

## **2. Main Components of Overhead Transmission Line**

An Overhead Transmission Line may be used to transfer electric power. The satisfactory performance of a Transmission Line greatly depends on its mechanical design. In establishment of a transmission line, it must be confident that mechanical strength of the line is such so as to provide adequate strength against the expected climatic conditions. Normally, the main components of a Transmission Line are:

- (i) Conductor and Shieldwire
- (ii) Steel Structure
- (iii) Insulator
- (iv) Hardware and Fittings
- (v) Foundation and Grounding System

### **2.1. Conductor and Shieldwire**

Of all the components that are making up a transmission system, nothing is more important than the conductors.

A large number of conductor constructions and compositions nowadays are in use to create variety of requirements. In the early years of the industry, because of its high electrical conductivity, copper was almost exclusively used, though having low ratio of strength to weight which resulted in shorter distance among towers. Later on, as an alternative to copper, aluminum was introduced because of higher ratio of strength to weight, allowing design with longer spans. Although aluminum has lesser conductivity than copper, it is more economical to use since it has more reasonable ratio of conductivity to weight.

There are a number of variables and factors that are to be considered when dealing with conductors. These may include:

- Conductor type
- Conductor size
- Conductor ampacity
- Conductor thermal capacity
- Conductor Tensile Strength

Among the available types of conductors, ACSR (Aluminum Conductor Steel-Reinforced) is the most common type of conductor being used today. These conductors have been given bird names. It is made of layers of stranded aluminum wire with core of high-strength galvanized steel. The number of strands in core depending on the size. Since different stranding combinations of aluminum and steel wires can be used, it is possible to vary the proportions steel to and aluminum to achieve a thorough range of current carrying capacities and mechanical rated tensile.

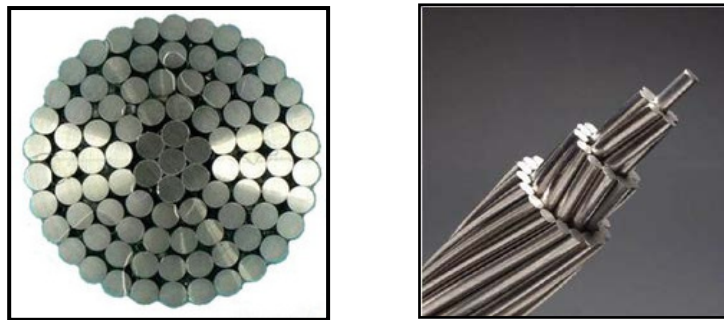

**Figure 2.1**  
**ACSR Conductor Type [24]**

Conductors are composed of conducting material that are affected by everyday stress tension, current that causes heat and natural wind and ice loading. Temperature of Conductor constantly changes influenced by of ambient temperature, ice, and wind. Changing temperature lead to conductor's tension changes. Mechanical design of the conductor must observe ice and wind loads that occur in the area of the Transmission Line

during the service time life. Because of winds blowing, Conductors are subject to constant Aeolian vibration.

### **2.1.1 High Temperature - Low Sag Conductor**

Since construction of new Transmission Lines is usually difficult and expensive, it is intended to increase the current carrying capacity of existing Lines, in order to minimize the number of new Transmission Lines that should be constructed. High current produce significant conductor heating, and this heating leads to conductor sag increase, which can limit spans length or increase structures height. There are newly developed conductors with better mechanical performance than conventional conductors. They are more expensive, and be used for upgrading existing line, as well as for new projects.

Aluminum Conductor, Steel Supported (ACSS) is a steel core low sag conductor. Unlike ACSR, in ACSS Conductor, the steel core provides almost all of the tensile strength, while the aluminum is fully annealed and carries little tension because of its more coefficient of expansion. ACSS Conductors may be constructed as compact conductors. In some cases, they are built of trapezoidal wires with similar cross-sectional but more conducting area which can replace conventional conductor with same diameter.

Aluminum Conductor, Composite Core (ACCC) is a composite core of carbon-fiber and epoxy strands, and completely annealed aluminum. The thermal operating range is lower than ACSS Conductor of similar size. While Sag performance of ACCC is much better than ACSS, and its thermal operating in comparison of ACSS in lower.

Overhead Ground Wires (OHGW) is usually made of High Strength or Extra High Strength Galvanized or Aluminum-Clad Steel Strand. Selecting an overhead ground wire size and type is depending upon how the sag of the OHGW coordinates with that of the phase conductors, as well as the resistance and conductivity of the Ground Wire. If a line is to be built in a coastal area or in location that there is a highly corrosive atmosphere, aluminum-clad steel wire is recommended.

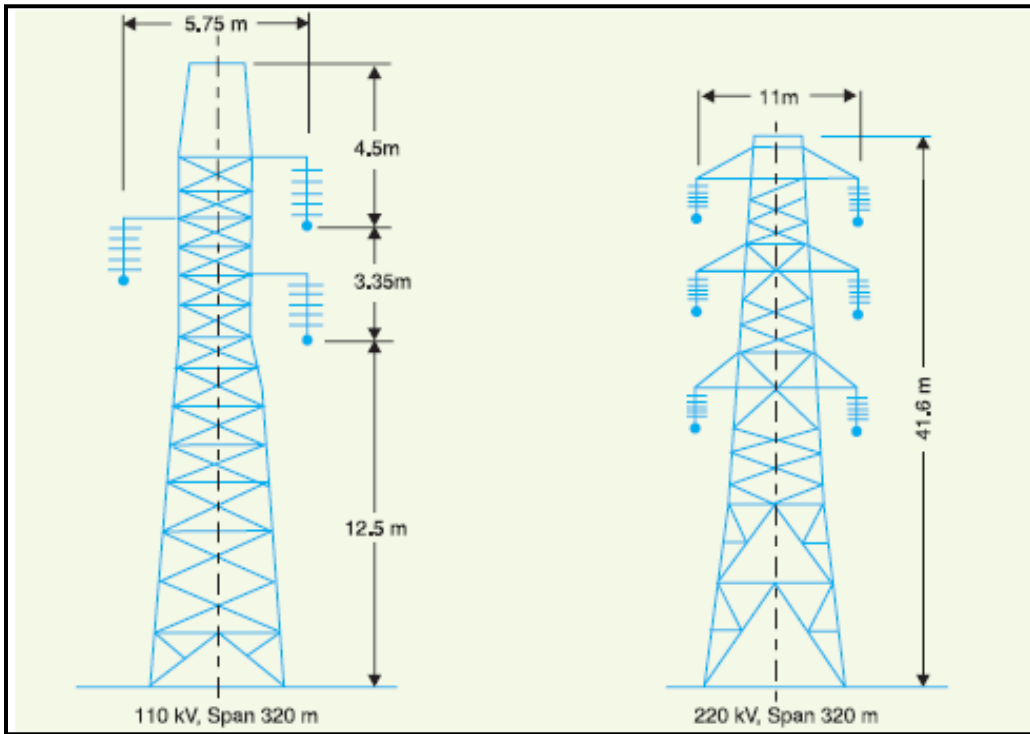

**Figure 2.2**  
**ACCC and ACSS Conductor Types [26, 29]**

## **2.2. Steel Structure**

Structures, in different types of Poles or Lattice Towers, are required to support the Conductors and Insulators, as well as support themselves (guys may be required) in different imposed weather condition, mainly caused by wind and ice. Loads emerging in maintenance and construction also should be supported. Structures, with best selected geometric configuration, must be able to isolate the high voltage from public activity and provide a safety to the utility workers. By providing shielding from strokes of lightning, they also enhance the electrical performance of the Line and maintain sufficient clearances in swinging of insulator string.

Materials which are used in tower manufacturing have normal variations and manufacturing processes, and usually fabricated according to standards such as ASTM. The standard clarifies testing procedure and strength to make sure that the material meets the required strength. Typically, in test process material will exhibit a range of strengths, and the standard, based the results of the test will specify the rated strength. Structural materials strength decrease over time due to decay or rot. The design criteria should consider these effects by applying a strength reduction factor applied to nominal strength of members of structure which are subject to deterioration.



**Figure 2.3**  
**Typical Lattice Steel Structure [7, 27]**



### 2.3. Insulator

Insulators are essential for electrical insulation of energized conductor and also for conductor support physically. From electrical point of view, the role of the insulators are to provide sufficient insulation against phase-structure flashover. Mechanically, insulator also withstand the wind and ice load, and the conductor tension and weight. Types of insulators that are being used are glass, composite and porcelain, and the configuration to be used can be “Vee” or “I” string. The electrical and mechanical properties of the insulators are matter of importance. The electrical specifications such as wet and dry flashover, power frequency, and impulse withstand voltage are important to the electrical performance of the line and should be tested before usage. The mechanical strength of the insulators is necessary for reliability and physical integrity of the line and must be carefully checked. Insulator material and physical configuration affect the mechanical and electrical properties. Selection of insulators should be based on strength requirements, pollution level resistance, impulse voltage requirements and power frequency. Insulator properties may vary by manufacturer and type. The reasons for type and configuration selection must be documented.



**Figure 2.4**  
**Porcelain and Composite Insulators [20, 21]**

## **2.4. Hardware and Fittings**

Hardware for transmission lines can be divided to conductor-related hardware and structure-related hardware. They are most exposed to danger and easily damaged. In the design of Transmission Line, special consideration should be given to mechanical and electrical requirements on the design of conductor-related hardware which are involved in support and join the overhead conductor and ground wire. Conductor motion hardware is used to decrease damage to the overhead conductors through vibration. Selection and proper installation of hardware will have considerable influence on the operation and maintenance of a transmission line. Electrical, mechanical, and material design considerations are generally involved in the design of conductor support hardware and conductor motion hardware. Selection of conductor-related and structure-related hardware should consider damage and degradation of strength of material. In addition to selecting hardware made of materials that are less likely to corrode, the materials selected should be compatible with one another and will not corrode when in contact with each other.

## **2.5. Foundation and Grounding System**

Foundations are usually designed either for maximum load or specific loads. The economical and best approach is to apply standardized and specific design together. There are different sorts of tower foundations such as direct embedment, steel grillages and pile foundation. Selection of type is based on design and availability.

Lateral forces are imposed to every structure standing above ground. Types of foundations to be used in different kinds of Transmission Line can vary from direct embedment in poles with backfill to pad and chimney foundations. Different foundations are used on different sections of the Line, for different soil conditions. Since foundations are difficult to repair or replacement, they are often designed with added load factors so that they are stronger than the structures they support which makes it easier for structure restoration in the event of damage to a structure. Soil properties like friction and unit weight, elevation of the water table and bearing and lateral pressures are important in the design and application of foundations. The soil properties used for foundation design may be based on a geotechnical

investigation of the soil or on the basis of geotechnical properties typical of the soils existing in the project area. The loads transmitted to the foundations in lattice towers, and similar structures are mainly compression/uplift loads.

Excavated foundations need of compaction, which must be carefully inspected. In the design of foundation, amount of compaction that might be obtained are taken into consideration.



**Figure 2.5**  
**Execution of Foundation -1 [19]**



**Figure 2.6**  
**Execution of Foundation -2 [19]**

### **3. General Design Criteria**

#### **3.1. Methodology**

Transmission Line must be engineered and then established in such a way that in all over its planned life time can fulfill its purpose within defined conditions. It should be designed to prevent cascading failure, and also must be designed to avoid human injuries or loss of life during construction and maintenance.

In design of a Transmission Line, special cares should be given to, environmental considerations and appearance, maintainability and durability. These requirements will be met by suitable design and selection of suitable materials and precise control procedures for and construction and manufacturing.

The methodology is based on the truth that a Transmission Line consists of different components like foundations, steel structure, conductors, shieldwire, insulator and hardware. This special looking causes the engineers to coordinate components strength and realize the fact that the failure of any component may eventuate to the power loss, since Transmission Line is made of a series of components. This approach will lead to a general economical engineering without any unwanted mismatching. As a result of this approach, it can be inferred that the least reliable component controls the reliability of Line.

#### **3.2. Reliability**

The goal of design criteria is a safe and reliable Transmission Line. Transmission Line is reliable if components strength requirements larger than the effects of weather load imposed. Reliability purpose is to be confident that Lines can withstand the ice, wind and ice with wind climatic limit loads in return period.

Determination of absolute reliability of Transmission Line is generally difficult. It is possible to design Transmission Lines for different reliability levels. Usually, 50 year return period climatic event is considered in Line design. With regard to continuation of service

and safety, this reference reliability is usually respected as an acceptable level. With increase of return period of climatic events, Line is designed for higher reliability level. Higher reliability is justifiable by the importance of Transmission Line in the network. In IEC 60826 standard, three reliability levels are suggested, and presumably cover all value ranges to be considered for most Transmission Lines. The levels of reliability are stated in terms of climatic limit return periods loads as shown in Table below. For Lines of less importance or some wooden poles, the accepted return periods may be 25 years.

<b>Levels of Reliability</b>	<b>1</b>	<b>2</b>	<b>3</b>
<b>Return period of climatic loads, in years</b>	<b>50</b>	<b>150</b>	<b>500</b>

### **Reliability Level for Transmission Line**

Hence, it should be noted that other conditions not related to Line design such as defects in material, might happen and lead to failure of Transmission Line.

### **3.3. Climatic Load – Strength Requirement**

Meteorological Organization usually maintains climatological data that can be helpful to characterize the weather conditions in Transmission Line area. It renders best resources for hardest weather condition that might be regarded in Line design. In this case, realistic information of weather conditions should be selected.

The strength to be designed for a Transmission Line depends greatly on iced and wind loads that possibly are imposed on steel structure and conductor. These loadings are mainly related to the location of the Line. While suitable design loads being selected, besides climatic conditions, experience of previous Line operation and the importance of the Line to the network should be considered. Special care should be taken to Transmission Line which is the only connection to important substation or load.

Loads due to climatic condition which rule the Transmission Line reliability for the expected life time are analyzed in the following sub-clauses:

- Wind Loads
- Ice without Wind
- Ice with Wind

Wind speed which corresponds to a return period may be defined by analyzing of related velocity of wind record at 10 m above ground considering average period of 10 minutes. Normally, velocity is recorded in the area with very few barriers, for instance fields with few buildings or trees or airport. Unless proven special correlation, it is usually presume that wind velocity at maximum level is not simultaneous with minimum temperature. Eventually, for design criteria, two combinations normally will be considered, reduced wind at lowest temperature and maximum wind velocity at daily temperature.

In Transmission Line designs, it is important to register the wind velocity applied for the design and the reasons for adopting such values. In addition to the selected values for design, the value of the different safety factors used to calculate the loads imposed to the structure types also must also documented.

In the components design calculation, the following condition has to be checked:

$$\mathbf{“(Design\ limit\ load)(Safety\ factor) < (Design\ Strength)”}$$

Loads and safety factors used in the design of the Line can be used to realize mechanical abilities of the Line, and used in future by design engineers who are involved in up-rating or tower replacement.

Meanwhile, broken-wire, maintenance and construction load should be considered. Information should be indicative of structure reaction to the broken wire, and each maintenance and construction load. Loads and safety factors for each types of construction may be helpful for site supervisors and workers during maintenance works and construction activities.

### 3.4. Considerations in Finland

The Finnish National Committee has prepared Part 3-7 of EN 50341, Overhead Electrical Lines Exceeding AC 45 kV, General requirements – Common specification, and has listed Finnish national normative aspects. The EN 50341-3-7 is regulating in Finland and informative for other countries.

#### Reliability Levels

A definition of reliability in transmission line was described before in section 3.2. The reliability levels practiced in Finland are as follows:

- Level 1, return period of 50 year climatic condition: Unimportant or temporary lines
- Level 2, return period of 150 year climatic condition: Normal lines
- Level 3, return period of 500 year climatic condition: Very important or special lines

#### Wind Speeds

As explained in section 3.3, determination of wind load imposed on transmission line component is usually based on meteorological information.

Following values for reference wind speed are given:

$$V_R (II) = 21 \text{ m/s for main land}$$

$$V_R (II) = 25 \text{ m/s for off-shore places}$$

The wind blowing in the elevation of 10 meter over the project area is called reference wind speed.

Having reference wind speed  $V_R (II)$  at the nearest site of measuring, and by using terrain factor and ground roughness parameter, reference wind speed exactly at site is calculable.



## Conductor Ice Load

Ice load defining for calculation of conductor sag and tension in ice condition depends on the relative altitude, and is summarized in table below:

<b>Relative Altitude (m)</b>	<b>Reference Ice Load (N/m)</b>	<b>Ice Density <math>\text{kg/m}^3</math></b>	<b>Ice Type</b>
0-50	10	500	rime
50-100	25	500	rime
100 -200	50	500	rime
more than 200	75	500	rime

## Minimum Temperature

The minimum temperatures with respect to reliability level return period and also different region in Finland are specified as follows:

<b>Temperature Region</b>	<b>Reliability Level 1 °C</b>	<b>Reliability Level 2 °C</b>	<b>Reliability Level 3 °C</b>	<b>3-year °C</b>
Southern Finland	-40	-45	-50	-30
Middle Finland	-45	-50	-55	-36
Northern Finland	-50	-55	-60	-42

Usually, return period of three year value as minimum design temperature is taken into account.

## Maximum design temperature

Maximum design temperature for conductor and groundwire are:

Conductor: 70 °C

Groundwire: 40 °C

Maximum temperature for conductor happens while there is maximum solar radiation, and at the same time, the conductor is carrying maximum current in full load condition.

## 4. Mechanical Calculation Principles

### 4.1. Conductor Sag and Tension

The difference in level between the lowest point on the conductor and points of supports is called sag. The sag of Conductor is a matter of importance in Overhead Lines mechanical design. The sag of conductor must be kept to lowest possible value to prevent unnecessary tower height for proper clearance and also decrease the required conductor material. At the same time, it is preferable that conductor tension to be kept low enough to prevent conductor mechanical failure and possible to use less strong steel structure. In Transmission Line design, it is tried to make compromise between these two parameter, Since low sag represents high tension and tight wire and, while low tension represents increased sag and loose wire.

Tension depends on unit weight of conductor, wind velocity, ice loading, variations of temperature, as well as conductor technical specifications. We try to adjust the sag properly so that the tension will be within safe limit. Tension of conductor in hardest condition is usually less than 50% of its ultimate tensile strength. Minimum safety factor of conductor is expected to be at least 2, or even higher.

Figure 4.1 demonstrates a suspended conductor between two equal level points  $A$  and  $B$ . The conductor is allowed to have a dip and not fully stretched. The lowest point of the conductor is point  $O$  and the sag is  $S$ .

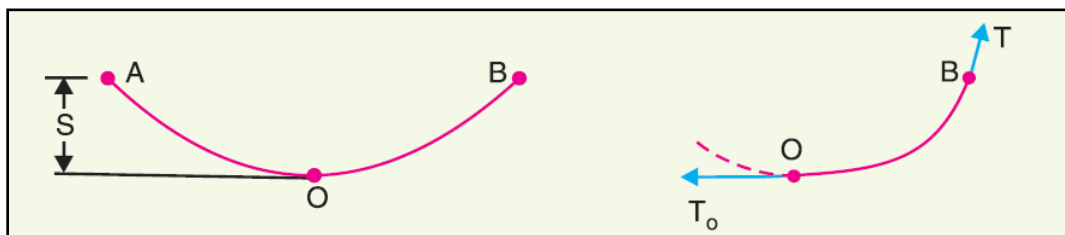

**Figure 4.1**  
**Same Level Suspended Conductor [7]**

Tension inside conductor at any point tangentially acts. Therefore tension  $T_o$  at point  $O$  which is the lowest acts horizontally as illustrated in Fig. 4.1. The horizontal component of tension in all over the conductor length is constant, and tension at attachment points is almost equal to horizontal tension at any place of the Conductor. Therefore, if  $T$  is the tension at the attachment point  $B$ , then  $T = T_o$ .

While conductor is placed in the same level attachment points, it takes the shape of catenary. Conductor weight is supposed to be distributed evenly in a span along the conductor sag curve. When the sag is insignificant compared to the span, then sag-span curve is similar to a parabola. The parabolic equation is mostly used for sag and tension calculations for distribution and transmission lines.

Distance between any two structures is named span .The easiest sag calculation is based on conductor with dead-end span which supported rigidly at same elevations. It is also assume that conductor length does not change with variation of temperature or stress. Figure below shows the parabolic conductor sag curve. When conductor is strung between two same level points, fundamental sag of a conductor will be calculated as follows.

$$S = \frac{H}{W} \left[ \text{Cosh} \left( \frac{wL^2}{2H} \right) - 1 \right] \quad (4.1)$$

This function is often simplified as:

$$S = \frac{wl^2}{8H} \quad (4.2)$$

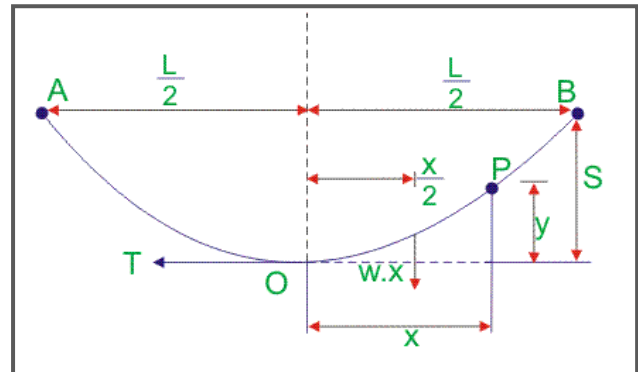

**Figure 4.2**  
**Parabolic Sag Curve [22]**

S = Conductor Sag (m)

L = Length of Span (m)

w= per unit Weight of Conductor (kg)

H= Horizontal Tension of Conductor (kg)

In flat terrain, towers which are used for transmission line construction are usually in similar height, and therefore leveled span are mostly observed. Inclined spans usually occur in hilly terrain, but observed in flat area, where two adjacent towers must have different heights to maintain certain clearance to ground. In below figures, difference between sag of leveled and inclined span is noticeable.

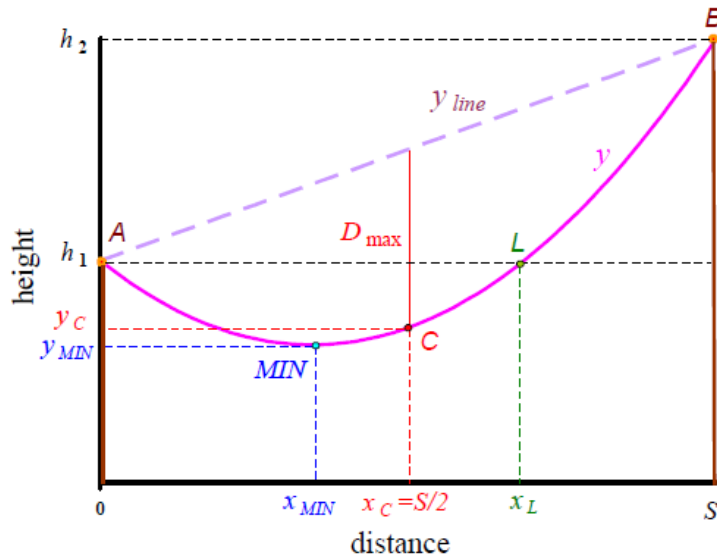

**Figure 4.3**  
**Leveled Span [10]**



**Figure 4.4**  
**Inclined span [10]**

Sag in equal level span is located in the middle of span, while lowest point in inclined spans can move to lower support.



**Figure 4.5**  
**Sag in Inclined Span [9]**

In inclined spans, maximum sag  $D_{max}$  is the vertical distance which is measured from the conductor to the straight line connecting the supports, as shown in figure above.

#### 4.1.1 Thermal Elongation, Stress Behavior

Generally, conductor elongates by everyday stress and permanent mechanical forces during its service duration. Meanwhile, conductor is subject to other elongation such as conductor temperature caused by climatic condition and current, as well as mechanical ice and wind load and long term creep. All kinds of elongations naturally increase the sag of conductor. They can be summarized as:

- Elastic elongation (reversible)
- Thermal elongation caused by environment temperature and current (reversible)
- Long - term creep elongation (permanent)

#### Thermal elongation

While a conductor is expanding because of heat, its total length and sag of the conductor increases.  $\alpha_T$  is coefficient of linear thermal expansion which can describe the elongation of

the conductor. The conductor length of a conductor, for temperatures  $T$  near initial of temperature  $T_0$  may be calculated as:

$$L_T = (1 + \alpha_T \times (T - T_0)) L_{T_0} \quad (4.3)$$

$L_T$  - Conductor Length at temperature  $T$ (°C)  
 $L_{T_0}$  - Conductor Length at initial temperature  $T_0$ (°C)  
 $\alpha_T$  - Thermal Expansion Coefficient ( $10^{-6}/^\circ\text{C}$ )

Each conductor has a specific linear thermal expansion coefficient. It mainly depends on the ratio of steel-to-aluminum area. The aluminum elongation rate is almost double as much as steel, therefore more percentage of aluminum in a conductor results in higher coefficient of thermal expansion. Thermal elongation is classified among elastic elongation, and so it is a reversible process.

### Stress behavior

Elongation also is appeared while conductor is under tension. At low stress, strain/elongation is almost linear and predictable. This linear behavior is called elastic. While tension is more than yielding stress, some part of elongation does not reverse and becomes permanent. Now, if tension/stress decreases, permanent deformation is noticeable, this is called plastic deformation.

Modulus of elasticity or Young's modulus is a parameter that measures resistance of conductor against elastic deformation while force is applied it. It is defined as the slope of stress-strain curve in the region of elastic deformation. Stiffer Conductor with more percentage of steel than aluminum has a higher modulus of elasticity.

Conductor length in the range of reversible behavior, with respect to stress  $\epsilon$  is described as:

$$L\sigma = L \times (1 + \epsilon_\sigma + \epsilon_C) \quad (4.4)$$

$$\epsilon_\sigma = \frac{\sigma}{E} = \frac{H}{E A}$$

$L\sigma$  – Length under stress  $\sigma$ , in m  
 $L$  – Length under no stress, in m  
 $\epsilon\sigma$  – Elastic strain, in m/m  
 $\sigma$  – Stress, in kg/mm<sup>2</sup>  
 $E$  – Conductor Modulus of elasticity, in kg/mm<sup>2</sup>  
 $A$  – Conductor Cross-sectional area, in mm<sup>2</sup>  
 $\epsilon_c$  – Conductor Plastic deformation caused by inelastic deformation and creep, in m/m

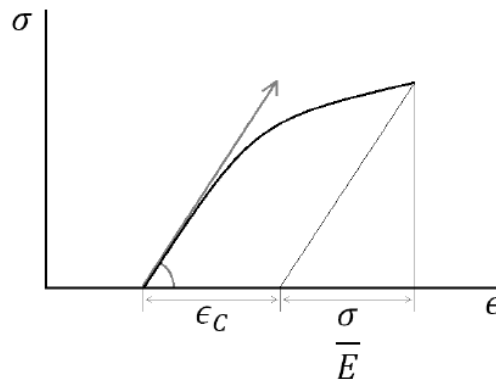

**Figure 4.6**  
**Conductor Stress-Strain relationship [4]**

#### 4.1.2 Aging Effect, Behavior of Layered Conductor

##### Aging Effect

Transmission line conductor is under permanent tension. During years of service, this tension tends to permanently stretch the Conductor. This conductor behavior is known as creep. On the other hands, creep is a gradual deformation of a conductor which is under stress and load. Plastic deformation usually happens when conductor is covered with a large amount of ice or is in storm condition, and high tension causes that conductor to be stretched beyond its yield stress.

Transmission lines are long-term investments. They are normally expected to be used for 40 years or even more, so it is very important to design a line that can operate safely for years in the future. Creep usually considered in design of a transmission line by considering 10-15 centigrade additional temperature in maximum temperature condition.



## Behavior of Layered Conductor

Conductors used in transmission lines are mainly combination of two materials. The most common conductor is Aluminum Conductor, Steel Reinforced (ACSR) | which has stranded steel core that is surrounded by aluminum layers.

Aluminum has conductive properties, while steel core provides a great amount of mechanical strength. Due to temperature and tension, steel and aluminum have expansion, but two materials used in ACSR conductor are expanding at different rates. At low temperatures, the whole conductor can be regarded as a combination of the properties of both steel and aluminum.

As temperature increases, majority of the tension is transferred to the steel core, and it will elongate similarly as regular steel conductor. High temperature cause slack is the conductor, therefore conductors operating at higher temperatures have lower tension. Steel core and aluminum conductor layers have different cross-sectional areas and different Modulus of elasticity, as well as different creep behavior and coefficient of thermal expansion.

As aluminum elongation is significantly more than steel, at higher temperature steel core tolerate almost the whole mechanical tension. This usually happens at knee-point of conductor.

### 4.1.3 Ruling Span, Sag-Tension Chart Determination

#### Ruling Span Definition

The equivalent or ruling span is defined as that span which acts identically to the tension in each span of a series of suspension towers located between two tension towers all under the same loading condition. In case that all spans in a line section among tension towers are of the same length and same wind loads, it will result in equal conductor tension in each and every span. But in practice, span lengths normally vary in a section, and temperature,

ice and wind loads changing result in tension of conductor to become greater in the longer spans and lesser in the shorter spans while compared to the tensions in equal spans.

Normally, the insulator strings have flexibility for movement. The insulator string begin to move when there is unequal forces at the attachment point to tower as there is tendency to reduce unequal tension. The unequal forces generate when tension among spans are not equal. This indicates that sagging of one span in a section is not isolated from the other spans. A ruling span is an assumption of uniform span which roughly represents the mechanical operation of a line section among its tension supports.

Ruling span is an equivalent span length that is based on average tension of the conductor and the total length in a series of spans which are pulled and sagged during construction works. Therefore, it is function of all the spans existing in the stringing section. This uniform span length permits clearances and sag of spans to be determined for conductor stringing, and cause equalization of tension in the conductor between two neighboring spans.

The ruling span can be calculated using:

$$RS = \sqrt{\frac{L_1^3 + L_2^3 + L_3^3 + \dots + L_n^3}{L_1 + L_2 + L_3 + \dots + L_n}} \quad (4.5)$$

RS - Ruling span in line section consisting of n spans

$L_1$  - Span length of first span

$L_n$  - Span length of last span

Ruling Span determination example:

Determine the ruling span for the line section given below using span as tower spotted.

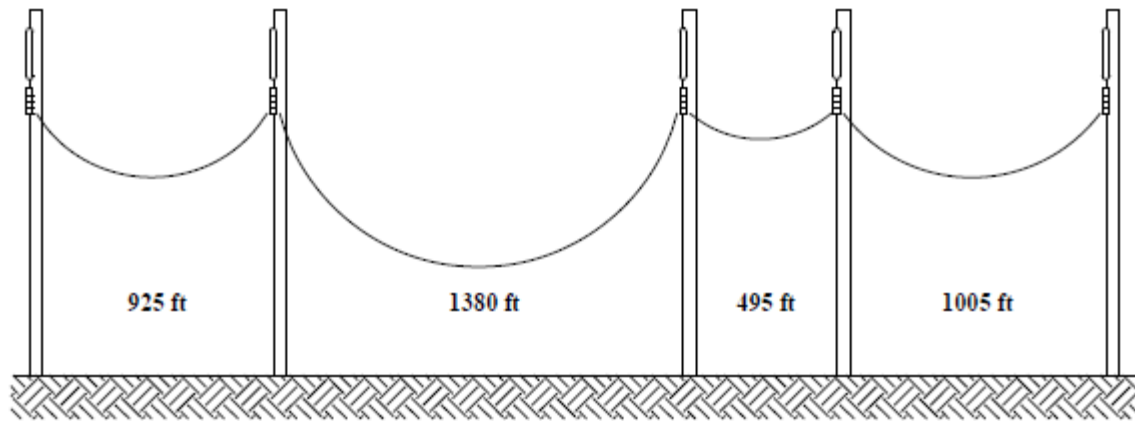

**Figure 4.7**  
**Line Section for Ruling Span Example [3]**

Solution:

$$RS = \sqrt{\frac{L_1^3 + L_2^3 + L_3^3 + \dots + L_n^3}{L_1 + L_2 + L_3 + \dots + L_n}}$$

$$RS = \sqrt{\frac{925^3 + 1380^3 + 495^3 + 1005^3}{925 + 1380 + 495 + 1005}}$$

$$RS = 1094 \text{ ft}$$

The ruling span “rules” the behavior of the sagged section of transmission line. The sag characteristics of the ruling span define the sag characteristics of each span in the section. If conductor is strung by a sag-tension table with the wrong ruling span, tensions and actual final sags would not be the same as expected. The error would be greater as the difference is greater.

### **Ruling Span Establishment**

As it can be inferred from Ruling Span Equation, the exact value of the ruling span only will be calculated after the tower spotting and when all lengths of spans exactly are determined. However, the ruling span should be considered in advance of tower spotting. Therefore,

the ruling span needs to be estimated before structure spotting on the plan and profile sheets. While pursuing any instruction for ruling span estimation, it should be regarded that ruling span estimation is an intuitive procedure based on trial and error and experience.

A good starting point for ruling span estimation is the base structure height. The base structure is the structure that is expected to use mostly in the transmission line. After assumption of a base structure height, the minimum ground clearance value must be subtracted from the height of the lowest phase conductor above ground on the tower. The founded sag which is limited by ground clearance is the result.

By applying this sag value and also tables for different ruling span, proper ruling span length can be chosen which its sag is approximately similar to the resulting sag for the base structure height. In fact, ruling span is selected to be same as the level ground span, and maximum span limited by ground conductor clearance for a particular height structure. This instruction of selecting a ruling span is useful either for flat or rolling terrain.

The ruling span value chosen initially must be checked to see if it coordinates properly with the span values as limited by factors such as ultimate tensile strength of conductor and structure strength. If the initial span selection to be found unsuitable, the value should be changed and the procedure repeated.

It is a common practice to allow long spans to double the average span without using termination towers, if conductor tension limits are in allowable range. Moreover, short spans must not be less than approximately half of the ruling span.

While plan and profile sheets are spotted, the estimated ruling span value will be checked by comparing it to the actual value calculated. It is not necessary that the estimated ruling span value be the same as actual value, in case that estimated ruling span results to be in satisfactory economical structure spotting and ground clearance, and without high conductor tensions. If the difference between the actual and estimated and ruling span is

more than almost 15 percent, the effects arising from the difference should be checked carefully.

### **Wrong Ruling Span effects**

It is so crucial that the actual ruling span be fairly near to the design ruling span value which is used for tower spotting. If not so, it might be noticeable differences between the expected tensions and clearances of the conductor and the actual values.

The amount by which actual sags and tensions differ from the expected values is a function of loading and conductor temperature. It should be noted that the sag change is dissimilar of variation of tension, meaning that increased sags lead to decreased tension and vice versa.

- If design Ruling Span is greater than actual Ruling span, actual sag is less than predicted, and it will lead to increased conductor tensions, which may be beyond the allowable loads of support and guying assemblies.
- If design Ruling Span is less than actual Ruling span, actual sag is greater than predicted, and it may result in inadequate ground clearances.

### **Conductor Sags -Tensions Chart Determination**

The sag and tension equation given at the beginning of this chapter is valid only when the length of conductor does not change significantly. In practice, Conductor lengths, and consequently the sags, change continuously

Sag, tension and Conductor lengths repeatedly change because of:

- Temperature fluctuations
- Wind and ice loads
- Elongation due to tension or stress

Given the fact that almost all conductor length changes are able to be estimated, sag-tension chart will be prepared accordingly. Prepared Tables will be able to predict the performance of the conductor sag and tension under expected upcoming service conditions. Conductor sags in different load cases and climatic conditions are needed to determine compliance with clearances required. Meanwhile, maximum conductor tension is needed to determine whether the transmission line is in compliance with strength requirements for towers and assemblies.

Future conductor behavior with respect to sags and tensions is greatly dependent on the tensions applied on the conductors while stringing. If sag or tension and temperature are known when the conductor is strung, sag and tension behavior for a dead-ended span is predictable for changing in loading, temperature, and creep. In other words, controlling the initial sag-tension controls future behavior of the conductor.

The required calculations to obtain the sag and tension behavior of a conductor are performed usually by software programs. Calculations consist of simultaneous consideration of equations for sag-tension relationships, conductor change length because of temperature and characteristics of conductor stress-strain. Following information is required as inputs to computer program:

- Design ruling span
- Length of Span
- Climatic Conditions and Loading Cases
- Limiting Tension Condition of Conductor
- Conductor Specific Characteristics

After the calculation, the program describes:

- Which limiting tension of controls the design
- Maximum sags is achieved by the maximum tension or by conductor temperature and creep
- Sags and tensions for all specified conditions

### Conductor design Tension Limits

Calculated sag and tension of a conductor is based on conductor size and type, design ruling span, loading conditions, and specified tension limit. Only one tension limit will control the design. Tension limits is specified for not exceeding the mechanical capability of conductor, support and assemblies. Usually conductor tension limit is specified in percent of the ultimate tensile strength of the conductor. Conductor tension should be designed so that it is always less than the allowable load on supporting structures, hardware and fittings, insulators and assemblies. It is required that all conductor tensions, wind, and ice loads to be multiplied by the appropriate safety factors.

The following list gives the characteristics of the conductor ACSR/HAWK/AW that is possibly selected for 132kV Transmission Lines. Aluminum conductor aluminum-clad steel reinforced (ACSR/AW) has an alum-clad core, which provides very effective protection against corrosion.

- Type: ACSR/HAWK/AW
- Stranding: Aluminum - 26/3.439
- AW wire: 7/2.675
- Diameter: 21.78 mm
- Area: 81.04 mm<sup>2</sup>
- Ultimate Tensile Strength: 8590 kg
- Weight: 0.929 kg/m
- Coefficient of expansion: 0.0000189/ °C
- Modulus of Elasticity: 7700 kg/mm<sup>2</sup>

In typical conductor calculation, tensions, which are applied to the selected conductor in different possible cases and based on climatic condition of Transmission Line area which is located in place with high wind but no ice, have been calculated. Input data and the results are shown in tables below.

No. Of conductor	No. of Loading Cases	Standard Span (m)	Step of Increase	Safety Factor	Span Iteration	Max. Permissible Tension EDS (%UTS)
1	6	310	10	2	2	.18

Conductor Name	Diameter (mm)	Area (mm <sup>2</sup> )	U.T.S. (kg)	Conductor weight (Kg/m)	E (kg/mm <sup>2</sup> )	ALFA (1/°c)
HAWK/AW	21.78	281.03	8590	.929	7700	.0000189

Shieldwire Name	Diameter (mm)	Area (mm <sup>2</sup> )	U.T.S. (Kg)	Sh/w Weight (kg/m)	E (Kg/mm <sup>2</sup> )	ALFA (1/o)
Core of HAWK/AW	8.02	39.42	4800	.308	16520	0.00001269

Loading Case	Temperature (°c)	Wind (m/s)	Ice (mm)
EDS	25	0	0
Max. Wind	10	45	0
Broken Wire	10	34.88	0
Max Temperature+Creep	100	0	0
Min Temp.	0	0	0
Normal Swing	10	13.9	0

### Conductor Mechanical Calculation

#### Input Data



**Note: All spans and sags are in meter and all tensions are in kilogram**

It can be inferred from the results that how wind and temperature affect the sag and tension. The safety factor of 2.0 has been considered in the whole calculation so that even in hardest condition, the tension does not exceed the 50% of ultimate tensile strength of the conductor. The output data later will be used in tower loading calculations and determination of the mechanical strength of insulators and hardware and fittings.

CONDUCTOR NAME is HAWK/AW

Span	EDS	Max wind	Broken wire	Max Temp+ creep	Min Temp.	Normal swing
310	1546.20 7.22	3685.34 8.80	2731.09 7.85	1136.86 9.82	1785.75 6.25	1722.65 6.69
<p>The hardest condition is Max Wind case with 3685.344 (kg) tension at span 310 (m)            Tension of hardest condition is %42.90* UTS            E.D.S tension is % 18.00* UTS            Shieldwire Tension at E.D.S is 640.78 kg            Sag Shieldwire at E.D.S is 5.77 m            Sag Shieldwire = 0.80* sag of conductor</p>						

SHIELDWIRE NAME is CORE OF HAWK/AW

Span	EDS	Max wind	Broken wire	Max temp.+ creep	Min Temp.	Normal swing
310	640.78 5.77	1418.31 8.33	1080.26 7.12	479.82 7.71	722.81 5.21	704.71 5.47
<p>The hardest condition is Max. Wind case with 1418.306 (kg) tension a t span 310 (m).            Tension of hardest condition. is %29.55* UTS</p>						

**Conductor and shieldwire Mechanical Calculations**

**Output Data**

As it can be inferred from the above tables, Conductor Sag in Maximum Temperature is 9.82 meter, while it is 6.25 meter in cold condition. Therefore the sag variation is 3.57 meter, as illustrated if figure below.

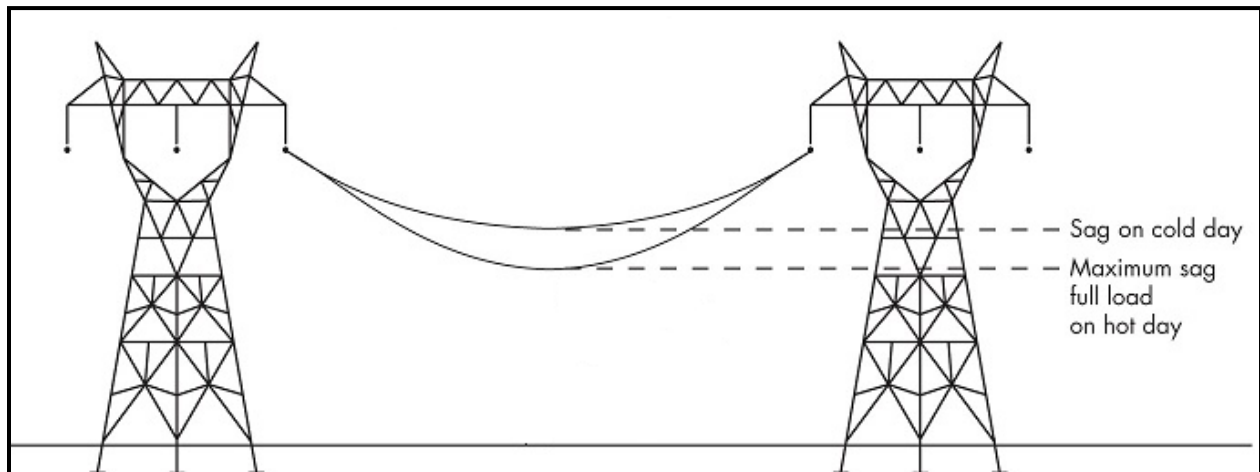

**Figure 4.8**  
**Sag Comparison in Cold and Hot Condition [23]**

### Stringing Conductors during Temperature Change

Conductor sag and tension chart normally indicate the changes that occur in different span lengths with a change of conditions. Spans with different lengths might have a tension rates varying with a change of loading or temperature.

The ruling span tension of an unloaded conductor matches the tension of any other span only at one temperature. Noticeable changes in temperature during stringing require attention in matching average tensions in any section. It is preferred to carry out stringing between dead-end supports at zero wind loads during periods of minimum temperature change. Where spans are consisting of suspension insulators, each span have an influence on adjacent spans meaning that no span can be considered independently of other spans in the same section between tension towers.

Long spans are affected more by loading, while temperature change has greater impact on short spans than loading does. In short spans, a little movement of supports lead to noticeable changes in tension, while in longer spans, greater movement is needed. Therefore, relation among adjacent span lengths determines the movement required to equalize tension. In conductor stringing operation, a series of spans is in same section normally sagged in one operation by pulling the conductors to proper tension while they are supported on free moving reel.

In order to achieve the accurate sags and to ensure that the suspension insulators vertically hang, the horizontal components of tension should be the same in all spans for a condition selected. In a series of spans of different length, bigger sags tend to form in the long spans.

#### **4.1.4 Wind and Ice Load on Conductor**

Load of ice on conductors is one of the most important parameter that may influence on the performance of transmission lines. Ice loading on the conductor of a transmission line usually occurs in snow or sleet condition, or even in ice melting in the forest.

It is extremely important to be able to calculate the maximum sag happening at such times. The reason for this is the necessity of calculating the height of the supporting structures and the vertical sag of the conductors, so that the conductor, even in the worse possible loading condition will not come in contact with the ground, and causing a phase-to-ground fault, or even come in contact with the other conductors in the same span, and causing a phase-to-phase fault.

In addition to these conditions, it is also necessary to be confident that conductor will not come close enough to the ground to endanger the lives of people in the vicinity.

Mechanical calculation of line conductor is made on the basis that curve of suspended conductor is a catenary. Effect of wind on conductors consists of loads due to wind pressure. The ice weight acts vertically in the same direction as the weight of conductor.

The force due to the wind is assumed to be perpendicular to the surface of the conductor. Therefore, the total force on the conductor is the vector sum of vertical and horizontal load.

Picture below clearly shows how ice load can greatly change the unit weight of conductor.



**Figure 4.9**  
**Ice on Conductor [28]**

Effect of wind on conductors consists of loads due to wind pressure. The ice weight acts vertically in the same direction as the weight of conductor. The force due to the wind is assumed to be perpendicular to the surface of the conductor. Therefore, the total force on the conductor is the vector sum of vertical and horizontal load.

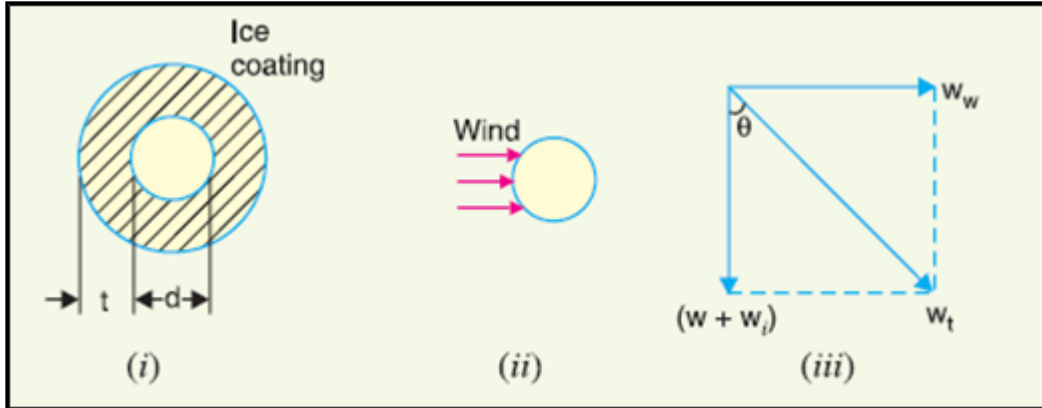

**Figure 4.10**  
**Effect of wind and ice on Conductor [7]**

Conductor unit weight influenced by wind and ice can be calculated as follows:

$$W_t = \sqrt{(W + W_i)^2 + (W_w)^2} \quad (4.6)$$

$W_t$  = Total Conductor Weight per unit length influenced by ice and wind

$W$  = Conductor Weight per unit length

$W_i$  = Ice Weight per unit length

= Ice Density  $\times$  volume of ice per unit length

= Ice Density  $\times \frac{\pi}{4} [(d + 2t)^2 - d^2]$

= Ice Density  $\times \pi t (d + t)$

$W_w$  = Wind Force per unit length

= Wind Pressure per unit area  $\times$  projected area per unit length

**Example.**

Transmission Line with the span of 275 m between level supports has a conductor with effective diameter of 1.96 cm and unit weights of 0.865 kg/m. Conductor ultimate strength is 8060 kg. If conductor has radial thickness ice coating of 1.27 cm and subject to wind pressure of 3.9 gm/cm<sup>2</sup> of projected area, calculate sag for a safety factor of 2

Weight of 1 c.c. of ice is 0.91 gm.

**Solution.**

Span length,	$l = 275 \text{ m}$
Conductor unit weight	$w = 0.865 \text{ kg/m}$
Conductor diameter	$d = 1.96 \text{ cm}$
Ice coating thickness	$t = 1.27 \text{ cm}$
Working tension	$T = 8060/2 = 4030 \text{ kg}$

$$\begin{aligned}\text{Ice Volume per Conductor meter Length} &= \pi t (d + t) \times 100 \\ &= \pi \times 1.27 (1.96 + 1.27) \times 100 \\ &= 1288 \text{ cm}^3\end{aligned}$$

$$\text{Ice Weight per Conductor meter length } W_i = 0.91 \times 0.1288 = 1.172 \text{ kg}$$

$$\begin{aligned}\text{Wind Force per Conductor meter length } W_w &= [\text{Pressure}] \times \text{projected area per unit length} \\ &= [\text{Pressure}] \times [(d + 2t) \times 100] \\ &= [3.9] \times [(1.96 + 2 \times 1.27) \times 100] \\ &= 1755 \text{ gm} = 1.755 \text{ kg}\end{aligned}$$

$$\begin{aligned}\text{Total Conductor Weight per meter length } W_t &= \sqrt{(W + W_i)^2 + (W_w)^2} \\ W_t &= \sqrt{(0.865 + 1.172)^2 + (1.755)^2} = 2.688 \text{ kg}\end{aligned}$$

$$\text{Sag} = \frac{W_t l^2}{8H} = \frac{2.688 \times 275^2}{8 \times 4030} = 6.3 \text{ m}$$

Wind imposed on conductors will increase the tension that can be calculated with standard sag-tension methods. Tension and safety factor must be observed in the hardest condition. Curves below how conductor sag varies in different conditions.

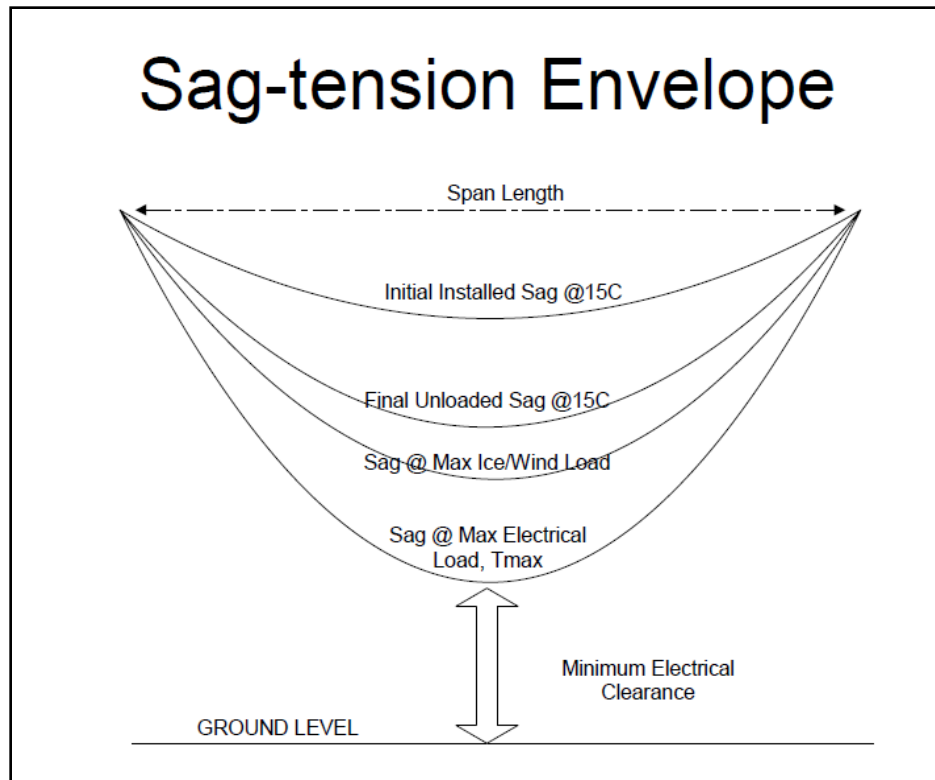

**Figure 4.11**  
**Sag-Tension Envelope [28]**

## 4.2. Load on Support

### 4.2.1. Application, Configurations and Material of Structures

Structures in Transmission Lines support the phase conductors and shield wires. Structures used commonly in Transmission Lines can be lattice type or pole type. Lattice structures are normally made of steel members. Poles may be steel, concrete or wood. Each structure sort may also be guyed or self-supporting. Structures have three main configurations: vertical, horizontal, or delta, depending on number of circuits and phase conductor arrangements.

Lattice steel structures usually are used for the transmission level voltages while wood pole structures are economical to be used for rather lower voltages and smaller spans. In regions with harsh climatic condition and for transmission lines with higher voltages and

multiple conductors per phase, concrete or wood structures to support large loads are not economical, and steel structures are more cost-effective option.

While evaluating types of structures to choose, construction accessibility of the line should be considered. Swampy conditions or mountainous terrain may cause the access difficult. Building access roads for construction of line and future maintenance is unavoidable, although in order to minimize environmental impact, sometimes line construction must be without establishing permanent access road.

Maintenance of structure is a function of material of structure. Lattice towers are usually made of galvanized steel, and it needs periodic inspection and paint. If Transmission line located in remote area, and does not have permanent access road, possibility of visit and maintenance of the line is a crucial consideration for structure material selection.

When selection of basic structure type is finished, a family of structures depending on the angle point, route of line and crossing terrain category should be designed. Designed structures include suspension, tension and dead-end towers.

Suspension towers are utilized when line direction is undeviating or has a negligible angle, commonly not more than three degree. Tension towers are suitable for deflection points of the line. Usually one tension structure is enough in flat terrain and in lines with almost equal span length. In hilly or mountainous area, where span lengths vary, and some long valley crossings are inevitable, second tension tower application and design is technically and economically justifiable.

The point where direction of line changes, is normally named as the point of intersection (P.I.) location. Tension supports are spotted at P.I. places, such that equalize the longitudinal conductor pulls in adjacent span, meaning that tower is executed in such a way that transverse axis of tower cross-arm, as shown in figure below bisects the line angle.



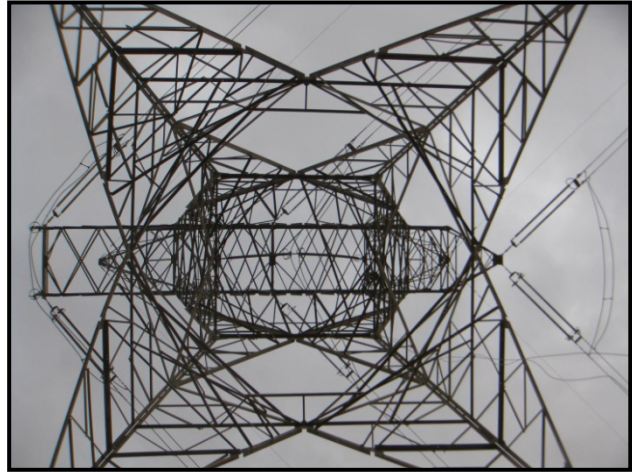

**Figure 4.12**  
**Line Angle bisected by Tension Tower [19]**

Dead-end structures have different applications. They can be used in points of intersections where line changes its direction with large angle. They are also designed to withstand tensioned conductor on only one side, meaning that they can mechanically resist against longitudinal forces. Due to this specification, dead-end structure may be used also for sectionalizing the line or used as terminal tower at the entry of the line to substations.

In mountainous area, dead-end support can also be used for withstanding uplift loads, exactly where there is large difference among tower location elevations.

Picture below illustrates the ability of one sided stringing in dead-end supports.



**Figure 4.13**  
**Dead end Structure - one sided stringing [19]**

#### **4.2.2. Types of Loading and Strength of Components**

Transmission lines should be designed to resist loadings of the four following types:

- Dead Load,
- Live Loads
- Failure Loads
- Safety Loads.

## Dead Loads

Dead loads are meant conductor weight and weight of insulators, hardware, fittings and assemblies. The amounts of dead loads are to be defined with reasonable certainty since the natures of such loads are deterministic. They can be added up and given a constant value for a certain configuration and structure.

## Live Loads

Live loads are randomly climatic loads which are produced by wind or ice. They can act separately or in combination. Because of the nature and origin of such loads, they can be statistically treated.

Usually in a certain return period, extreme values of ice and wind are to be used to calculate loading values. Data usage with longer return period lead to higher reliability since reliability of line varies using different return period for climatic loading design.

As mentioned in chapter 3.2, usually 50-year return period is taken into consideration for wind load calculation. This special wind is assumed to happen in moderate temperature of the place that line is being established. Correction factor usually are applied to consider wind speed in height of conductor and peak of support.

Statistical data for ice loadings may not be readily available. For ice loading, design values can be received from utilities based on the long term operating experience or might be achieved by use of ice modeling software. Wet snow will probably produce higher design loadings than glaze ice, and Hoar frost can also generate significant loading and should be taken into consideration in the region subject to this kind of loading.

As explained in section 4.1.4, assumed values of ice loading is applied vertically to the conductor. Density value of ice will be according to published information or based on the measurement by the utilities over the years with respect to the type of the deposit. Combination of wind and ice loading is usually determined by combining maximum ice in the return period and 40 percent of wind load value of past 50 years.

Picture below shows a heavily ice-loaded tower in an extremely cold area.



**Figure 4.14**  
**Heavily ice - loaded Tower [30]**

### **Failure Loads**

Failure load is a kind of load that is initiated by a single component or structure failure and has potential to progress beyond its initiation location.

This kind of failure can lead to a tower cascade failure, in which structure fail like dominoes, and it ends when the failure reach a dead-end structure, or reach another stronger structure.

In design of Transmission lines, failure containment capability is taken into account by considering the following two methods:

- Every structure should be designed so that to be able to resist the torsional load equal to the residual static load (RSL) caused by the reducing or releasing conductor or shield-wire tension in the adjacent span. Residual static load in suspension structures is calculated with consideration of load reduction originating from structure deflection and insulator swing.
- Every five to ten kilometers, strong structures named anti-cascading structures must be inserted. Typically, this kind of structure is designed to resist loads because of the tension release of conductors under heavy wind and ice conditions. Dead-end or conventional heavy angle structures usually meet these requirements, and therefore can be used for such purpose.

Picture bellow illustrates an under operation structure failure.



**Figure 4.15**  
**Under Service Tower Failure [19]**

## Safety Load

These loadings are emerging during construction of line or maintenance activities. They must be carefully taken into account to prevent structure or any component failure and also to ensure the safety of workers during construction works and maintenance operations. As construction works and operations are not usually implemented during storm conditions, it is not necessary to apply wind or ice to the safety loadings. It is recommended to practice safety precautions during operation as indicated:

- Stringing works and sagging – Towers should be designed to resist tension of conductor and shield-wire equal to 1.5 times the sagging or 2.0 times the pulling tension. For more safety, Tensions will be calculated for the coldest temperature probably might happen during the stringing operation and sagging.
- Maintenance – Conductor attachment points and insulator string should be capable of tolerating at least twice the conductor weight on the structure at sagging work.

## Strength of Components

In determination of strength of transmission line components, two different factors must be taken into account. The first is nominal component strength and the second is strength coordination among different components of the line. As far as possible, it is desired to predict failure sequence.

Transmission lines should be preferably engineered with respect of failure sequence to minimize failure damage of a component . In failure sequence establishment, following items are advisable:

- The first component to fail must have the least impact on the other components. This fact can prevent cascading failure.

- Inexpensive components which are in series with costly components must be mechanically as reliable and strong as costly ones. This precaution should be highly practiced when the consequences of the failure is severe.
- Repair expense and repair time should be minimum.

#### **4.2.3. Transverse, Longitudinal and Vertical Forces**

Structure loads consist of conductor tension loads and wind which transmitted by conductors, as well as the wind loads that are imposing on tower themselves.

Loads on structures are calculated in three directions: longitudinal, transverse, and vertical. Longitudinal load is in line direction, and transverse load is perpendicular to the line direction.

#### **Vertical Loads:**

The vertical load on towers includes the conductor weight plus weight of ice and insulator string. Vertical load is applied to the end of cross-arm at conductor attachment point.

The weight span is the horizontal distance between conductor lowest points in the back and ahead span, on two adjacent spans. Lowest point is the point at which sag curve tangent is horizontal. Weight span represents the vertical load imposed to the cross-arm, and therefore it is used for mechanical tower cross-arm design.

Figure bellow illustrates weight span for Tower No.2 and Tower No.3.

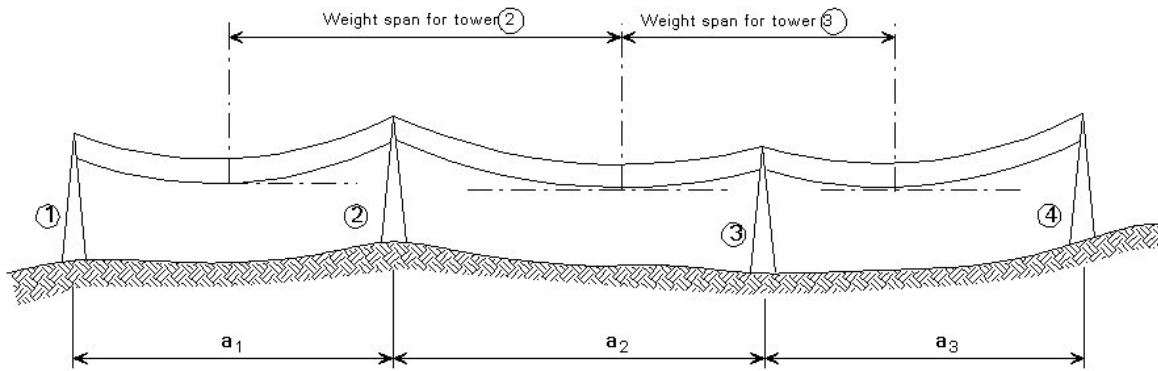

**Figure 4.16**  
**Weight Span Illustration [25]**

Vertical Load  $V_w$  is vertical load per conductor unit weight multiplied by weight span, which is horizontal conductor length between the low points in the right and left span.

Weight Span = Distance between low points of neighboring spans in (m)

$W$  = Conductor Weight per unit length in (kg/m)

$W_i$  = Ice Weight per unit length in (kg/m)

$V_w$  = Vertical Load

$$V_w = (W + W_i) \times (\text{Weight Span}) \text{ in (kg)} \quad (4.7)$$

### Transverse Loads:

Transverse loads are produced both by pressure of wind on structure and conductor, and also by the conductor tension transverse component. At the point of line direction change, the whole transverse load on the structure is adding up the transverse wind load and the conductor tension transverse component.

Wind span is the span in that, wind is presumed to act on conductors transversely and is equal to half of the sum of the two adjacent spans of support.



On the other hand, wind span, is simply half of ahead span plus half of back span length. The idea of wind span is that this value indicates the transverse wind load on tower, in which half the wind load is related to ahead and half the wind load is related to back span.

Picture below shows both weigh and wind span.

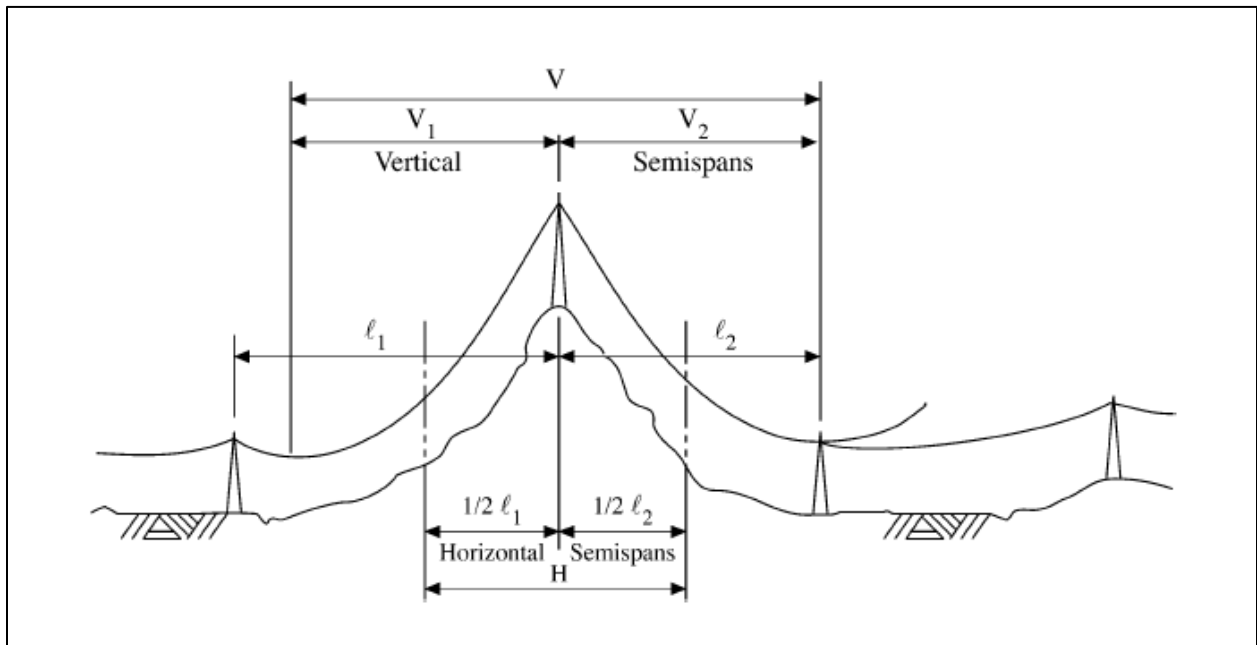

**Figure 4.17**  
**Weight and Wind (V and H) Spans [8]**

In order to calculate maximum transverse load, it is presumed that wind direction is perpendicular to the conductor.

Transverse load on the conductor produced by the wind can be given by the following equations:

$$\begin{aligned}
 W_h &= (\text{Wind pressure in kg/m}^2) \times (\text{Conductor projected area in m}^2) \text{ in kg} & (4.8) \\
 &= (\text{Wind pressure in kg/m}^2) \times (\text{Conductor diameter in m} \times \text{wind span in m}) \text{ in kg}
 \end{aligned}$$

There is another transverse load caused by line angle. The transverse component of the conductor tension might be noticeably large, for high degree direction change.

The transverse component of conductor tension applied on the cross-arm of support will be calculated by the bellow formula:

$$H = 2T \times \sin\theta / 2 \quad (4.9)$$

H = Transverse Component of Conductor Tension in kg

T = Conductor Tension in kg

$\theta$  = Line Angle in degrees

Besides the conductor load, towers are affected by wind load imposing on the exposed areas of the structure. The wind force rate on lattice towers depend on the member shapes and wind blowing angle.

### **Longitudinal Load:**

Longitudinal load usually appears in the direction of line, and happen when there is one-sided broken wire, or there is difference in tension in two adjacent spans of the line.

Longitudinal load can also emerge during stringing. In order to avoid any overstressing during stringing works, stringing tension should be restricted to the least value needed for maintain the conductor from contacting the ground. For this reason, stringing tension should be normally half of the sagging tension.

Suspension structures are not designed and expected to tolerate unbalanced longitudinal load. Only Dead-end Structures should be able of withstanding the conductor tension on one side of structure. For this ability, dead-end tower must be used as terminal tower at the entry of substations.

#### **4.2.4. Plan and Profile, Sag-Template and Tower Spotting**

##### **Plan and Profile**

Transmission line plan and profile drawings are prepared after and according to the route survey. Routing of transmission line needs a complete study and investigation and considering different alternate routes in order to ensure the most practical route is defined. In route survey, some crucial points such as construction cost, environmental criteria and impact, land acquisition, engineering and construction must be taken into account.

Once surveying of the route is completed, plan and profile will be drawn. Information on the plan and profile usually consists of roads, trees, swamps, forest, river and fences. Meanwhile, locations of other the transmission line and telecommunication system, which are crossing the line, must be shown in the plan.

The drawings also illustrate elevation and locations of all natural features and installations, railroads and river crossings existing on the route of line or are adjacent to the routes which probably affect line design and structure. Nowadays, special software is used to develop plan and profile once surveying data is imported.

Plan and profile will be used for tower spotting and completion of the design of the line. During supply of line material and also construction, the drawings are used to control procurement and volume of activities in foundation, tower erection and stringing. Final drawings will be considered as useful data for future repairmen and maintenance.

##### **Sag-Template**

Once plan and profile of the line is completely drawn, it is time to define the location of structures. For this purpose, sag template needs to be developed. Sag template is a scaling transparent plastic material manufactured according to conductor curve. First, on the paper and in correct scales, curves are plotted and then reproduced on the plastic material.

It is used for tower spotting and for illustrating vertical position of conductor, mainly in hot and cold condition, or in maximum and minimum sag. By using such template, it can be determined structure height and locations needed to satisfy design criteria for vertical clearances. Meanwhile, Uplift condition can also be checked by cold curve of the template.

Sag template of conductor must consist of the sag curves based on design ruling span as follows:

- Hot Curve: Corresponding maximum conductor temperature in operation with considering no wind and ice. It is used to check for minimum vertical clearances. Depending on the climatic condition, if maximum conductor sag occurs in ice condition, this sag curve must be regarded.
- Cold Curve: Corresponding minimum conductor temperature in operation with considering no wind. It is used to check uplift condition.
- Normal Curve: Corresponding everyday conductor temperature in operation with considering no wind and ice. It is used to check for normal vertical clearances.

The template must be manufactured to consist of spans almost three times as long as the design span for suitable structure spotting in steep terrain.

## **Tower Spotting**

Tower spotting is the design process in which type, height and location of tower on the plan and profile sheets are determined.

Tower spotting must greatly observe design criteria certified before, and transmission line safety and economy depends on how well structure spotting is fulfilled. However, encountered physical obstacles and other limitations can prevent to reach optimum location in the spotting.

Preferred targets of a well-established structure spotting are:

- Uniform span length, preferably similar to design ruling span or slightly less. Generally, if ratio rate of adjacent span length to be within 1.0 – 1.5, conductor tension differences are ignorable.
- Use of basic structure with similar type and height. Basis structure is the tower which is economical for design condition.

For line with limited constraints in location of structures, and in level and straight route, above-mentioned targets are easily achievable. More efforts and reviews are needed in mountainous area, where there are many high and low points on the profile, and are subject to crossing over other existing transmission and telecommunication lines, rivers railroad and highways.

The following design criteria should also be considered in spotting of structure:

- Horizontal Clearances  
Insulator swing, edge of right of way
- Vertical Clearances  
Ground level, crossing, under-built
- Weight and Wind Span Limitations  
Structure strength, cross-arm strength, galloping
- Uplift

Picture below shows part of a tower spotting of a transmission line. The yellow line is figuratively shifted-up ground level, tangential line to conductor hot cure should stand upper than that. It means that clearance between ground and conductor in maximum sag condition is at least equal to ground level shifting value that is minimum vertical phase-to-ground clearance.

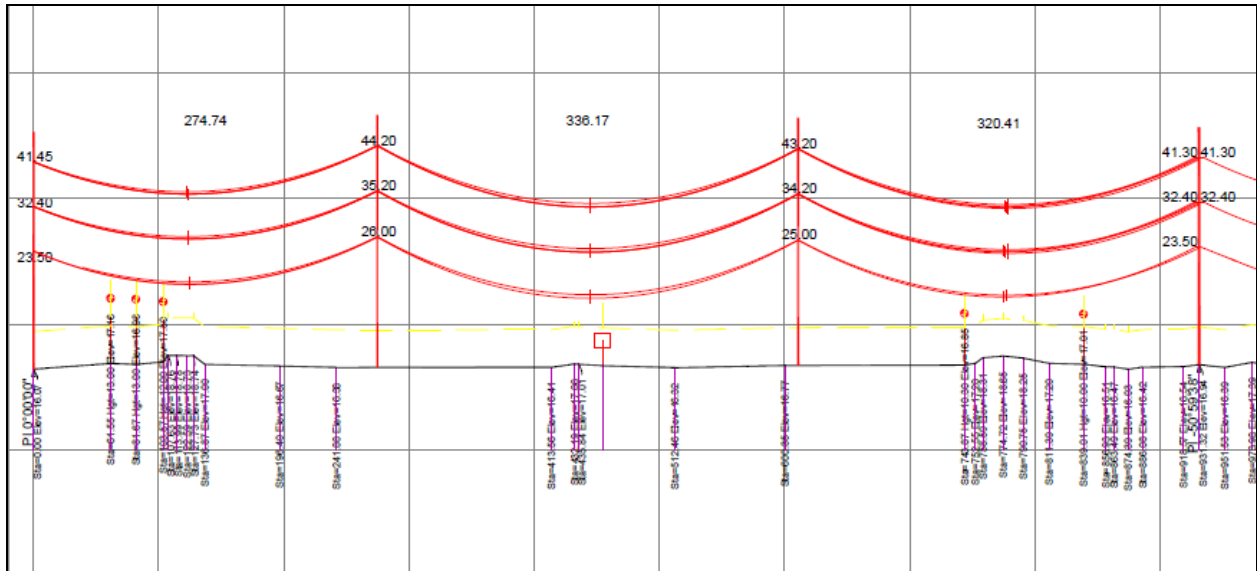

**Figure 4.18**  
**Tower Spotting Sample [19]**

In tower spotting, weight and wind span ratio must be taken into account. For suspension insulators which are hung from cross-arms, minimum weight span should be enough to prevent from excessive side swing. Considering this fact, wind span should not exceed maximum value.

#### 4.2.5. Uplifting and Galloping

##### Uplift

Uplift usually occurs in mountainous areas, and is described as negative weight span. When the lowest point of cold curve sag in mountainous area is situated above the lower tower, conductors in the upper spans apply upward forces on the lower support. On the other hand, if the upward load related to uphill span to be more than downward force of the neighboring span, uplift happens.

As shown in the upcoming picture, uplift emerges at a structure when the total weight span is negative.

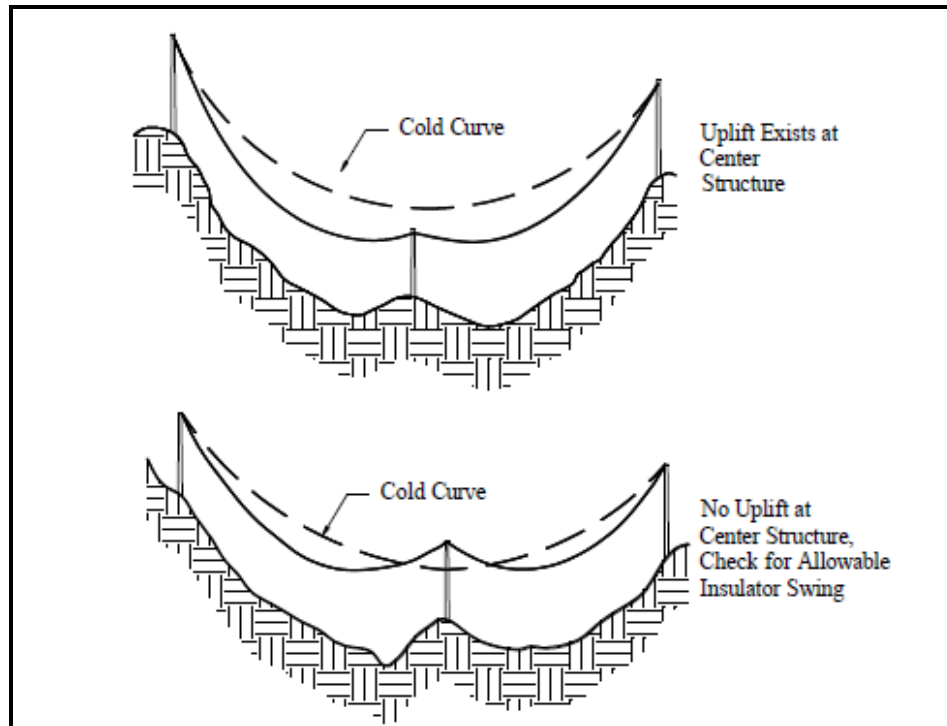

**Figure 4.19**  
**Cold-Curve check for uplift [3]**

Uplift has to be avoided for suspension towers. Also, poor soil foundation conditions should preferably be avoided for the structure locating at uplift.

In order to minimizing effects of uplift, and choose a suitable and safe design, dead-end or angle structure can be used in uplift condition. It is also recommended to increase to height of structure located at uplift condition to reduce uplift forces.

In some cases, it is preferred to use one long span between two dead-end supports with installation of phase spacer among conductors, instead of using to short span located in downhill. If so, it should be checked to ensure conductor tension remains within allowable limit.

### **Galloping**

Low frequency –very large amplitude vibration of transmission line conductor is galloping. This phenomenon is sometime call dancing. It is usually happens as the result of combination of conductor heavy ice and strong winds.

This large conductor movement might have following consequences:

- Conductor damage at insulator string point
- Phase-to-phase or phase-to-ground wire faults
- Increased sag because of conductor overstressing.
- Damage of structure in rare case

Galloping is emerged when a moderate or heavy but steady wind is blowing over an ice coated conductor. Ice deposit can be generated by sleet or freezing rain. Ice coating might have different thickness and can change the shape of conductor to elliptical or slightly out of completely round. When wind hits to this abnormal shape, it will lead to a lift and cause gallop in the conductor.

In galloping movement, the conductor at frequency of almost one Hertz elliptically vibrates and the vertical amplitudes reach to even one meter.

Conductor tension increasing can result in galloping movement reduction, however it is impossible to do so after the line is constructed.

Interphase spacer is considered as another solution to reduce or completely eliminate galloping impact.

Interphase spacers maintain conductors apart through mechanical coupling between phases, which are insulated by composite material. Two Composite insulator parts are linked together and the length is adjustable in manufacturing to fit the structure type and distance among conductors. Interphase spacer will be attached to the conductor by clamps which are existing at both ends.



Moreover, Interphases are designed based on electrical, mechanical and environmental characteristics of the line, and their application may reduce the number of towers needed when constructing new lines.

Besides proper performance against galloping, interphase spacers have some other benefits in usage and installation:

- Light and flexible
- High fatigue performance
- Resistant to deformation under compressive forces
- Easy and quick installation

#### **4.2.6 Unbalanced Longitudinal Load and Reasons of Failure**

##### **Unbalanced longitudinal load**

Several following reasons may cause unbalanced longitudinal loads in a Transmission Line:

- Broken wire
- Stringing loads
- Wrong ruling span selection
- Unequally differential ice load
- Maintenance and Construction works

Normally, suspension towers are not designed to withstand broken conductor longitudinal loads. Therefore, tension or dead-end structures with enough longitudinal strength are needed at locations where unequal tensions of conductor emerge.

In very long sections, especially in the line with high wind and heavy condition, it is recommended to use a structure with sufficient longitudinal capacity every five kilometers

to prevent progressive cascading failure. Normally, a section of the line is terminated by tension towers, as shown in picture below:

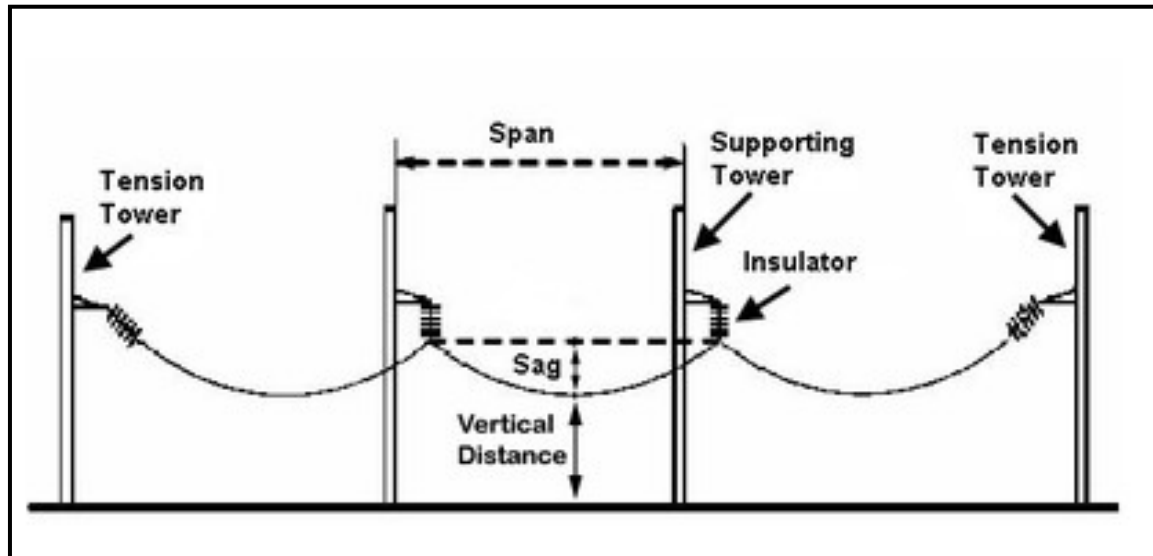

**Figure 4.20**  
**Transmission Line section terminated by Tension Towers [3]**

Summarization of methods to reduce the transmission line cascading failure because of broken conductor are:

- Using Stop Support: This method is application of a structure with adequate longitudinal resistance to minimize the number of cascading structures.
- Release Mechanisms: This method is using low-slip suspension clamp as a fuse during broken conductor condition to decrease unbalance load.

Unbalanced load is considered as a major reason for tower failure. Upcoming picture shows a failure in a suspension transmission line.



**Figure 4.21**  
**Tower Failure caused by unbalanced load [19]**

## Reasons of Failure

The following items summarize some general reasons related to failure of transmission line:

### A. Natural Causes (beyond expected condition):

- Extreme wind on both conductor and tower
- Extreme ice
- Combination of extreme wind and extreme ice
- Flooding which leads to damage to foundation or tower
- Landslides and snow slides

B. Unnatural Phenomena :

- damage caused by vehicles such as trucks and crane
- Tower member stealing or vandalism

C. Conductor or Hardware Defects

- Poor conductor quality
- Insufficient mechanical strength of fittings
- Conductor or fittings failure due to fatigue

D. Structure Defects (load condition less than design criteria):

- Structure wrong design
- Steel degradation or steel poor quality
- Structure missing bolts and members
- Structure misfabrication
- Foundation deficiencies

E. Maintenance and Construction Causes:

- Unexpected longitudinal load in stringing
- Unexpected vertical load in stringing

Following pictures illustrate tower failure caused by harsh climatic conditions.



**Figure 4.22**  
**Tower Failure caused by harsh weather condition -1 [19]**



**Figure 4.23**  
**Tower Failure caused by harsh weather condition -2 [19]**

## 5. Conclusion

Any failure to the electricity networks may lead to a vast blackout, and cause stop in economic activities and disruption in normal life. Therefore it should be possibly forecasted to prevent wide range effects of transmission line failure. The impacts can be local and national, and in some cases can be even international. The first practice in such incident is safety and then line repair power restoration.

Mostly, it is predicted that failures happen in unexpected or extreme climatic situations that exceed design conditions. At the same time, it should be taken into account that transmission line generally consists of conductor, ground wire, insulators, concrete foundation and galvanized steel structures, and degradation of material during the service condition can make the line vulnerable, and may be a factor, not a main cause, for failure. Periodical line inspections can detect the defects and renovation precautions reduce risk of failure.

Though having irreparable consequences, transmission line failure may give an opportunity to enlarge the understanding of transmission line performance and behavior. It also cause reviewing the design, weather conditions, safety factors and construction and maintenance procedures. Failure investigations must include both site observations and calculation reconsiderations. Collected data and findings must be transferred to storage area, and shared among utilities. The prepared reports will describe the reasons, actions and recommendation plans for failure prevention.

It is essential to be confident on failure causes, and then take the corrective measures to prevent recurrence of such incidents.

## References

- [1] IEC 60826 – Design Criteria of Overhead Transmission Lines  
Third edition 2003-10
- [2] IEEE Guide for the Preparation of a Transmission Line Design Criteria Document  
IEEE Std 1724™-2011
- [3] DESIGN MANUAL FOR HIGH VOLTAGE TRANSMISSION LINES  
BULLETIN 1724E-200 Revised May 2009
- [4] James Slegers, “ Transmission Line Loading, Sag Calculations and High-Temperature Conductor Technologies” 10/18/2011 [Online]. Available:  
<http://home.eng.iastate.edu/~jdm/wind/TransmissionLineLoadingDesignCriteriaAndHTS.pdf>
- [5] BS EN 50341 -1 Overhead Electrical Line exceeding AC 45kV  
Part 1: General requirements – Common Specifications
- [6] The Mechanics of Overhead Distribution Line Conductors  
UNITED STATES DEPARTMENT OF AGRICULTURE - Rural Utilities Service  
BULLETIN 1724E-152 July 30, 2003
- [7] Mechanical Design of Overhead Lines  
<http://www.nct-tech.edu.lk>
- [8] Fang, S.J.; Roy, S. and Kramer, J. “Transmission Structures”  
Structural Engineering Handbook  
Ed. Chen Wai-Fah  
Boca Raton: CRC Press LLC, 1999
- [9] Alen HATIBOVICS, “DETERMINATION OF THE LOWEST POINT OF THE CONDUCTOR IN INCLINED SPANS BASED ON A KNOWN MAXIMAL SAG OF THE PARABOLA”  
22nd International Conference on Electricity Distribution- Stockholm, June 2013
- [10] A.HATIBOVIC, “Derivation and Analysis of the Relation between Conductor Sags in Inclined and Leveled Spans Based on Known Data of the Latter”  
CIGRE 2014

- [11] Aluminum Conductor Composite Reinforced Technical Notebook (477 kcmil family) Conductor & Accessory Testing - November 2016 [Online]. Available: [http://www.3m.com/3MContentRetrievalAPI/BlobServlet?lmd=1162919024000&assetType=MMM\\_Image&locale=en\\_US&blobAttribute=ImageFile&fallback=true&univid=1114294275064&placeId=62603&version=current](http://www.3m.com/3MContentRetrievalAPI/BlobServlet?lmd=1162919024000&assetType=MMM_Image&locale=en_US&blobAttribute=ImageFile&fallback=true&univid=1114294275064&placeId=62603&version=current)
- [12] Stress Strain Creep Curves for Aluminum Overhead Electrical Conductor Technical Report of Aluminum Association's Electrical Technical Committee May 1997
- [13] Ch. Sudheer, K. Rajashekar, P. Padmanabha Reddy, Y. Bhargava Gopi Krishna "Analysis And Design Of 220kv Transmission Line Tower In Different Zones I & V With Different Base Widths" – A Comparative Study INTERNATIONAL JOURNAL OF TECHNOLOGY ENHANCEMENTS AND EMERGING ENGINEERING RESEARCH - 2013
- [14] Technical requirement for connecting to the Alberta Interconnected Electric System (IES) Transmission System Part 3 : Technical requirements for connecting Transmission Facilities - 1999
- [15] Gibson Peters, A. M. DiGioia, Jr., Chris Hendrickson, Jay Apt "Transmission Line Reliability: Climate Change and Extreme Weather" Carnegie Mellon Electricity Industry Center Working Paper CEIC-05-06 [www.cmu.edu/electricity](http://www.cmu.edu/electricity)
- [16] Transmission Line Design and Electrical Engineering hub [Online]. Available: [www.transmission-line.net/2011/06/uplift-insulator-swing-on-transmission.html](http://www.transmission-line.net/2011/06/uplift-insulator-swing-on-transmission.html)
- [17] Conductor Galloping Basics Part of a series of reference reports prepared by Preformed Line Products February 2016
- [18] Raghavendra Kulkarni, John McCormack "Forensic Engineering for a Transmission Line Failure" [Online]. Available: <http://www.asec2014.org.nz/Presentations/PDFs/Paper%20089%20Forensic%20engineering%20for%20a%20Transmission%20line%20Failure.pdf>
- [19] Projects Database of Transmission and Distribution Networks Department Ghods-Niroo Engineering Company [www.ghods-niroo.com](http://www.ghods-niroo.com)



- [20] [Online]. Available:  
[http://www.hivoltinsulators.com/Products/Composite\\_Insulator/index.html](http://www.hivoltinsulators.com/Products/Composite_Insulator/index.html)
- [21] [Online]. Available:  
<http://www.orientinsulators.com/technic/Features-of-Disc-Insulators.html>
- [22] [Online]. Available:  
<http://www.electrical4u.com/sag-in-overhead-conductor>
- [23] [Online]. Available:  
<http://www.hydroone.com/OurCommitment/Environment/Pages/Vegetation.aspx>
- [24] [Online]. Available:  
<http://www.stabiloy.com/CablePublic/en-US/Products/Energy+Cables/TransPowr+Bare+Overhead+Conductors/All+Aluminum+Alloy+Conductor.htm>
- [25] [Online]. Available:  
<http://fgg-web.fgg.uni-lj.si/~pmoze/esdep/master/wg15c/10300.htm>
- [26] [Online]. Available:  
[https://www.google.com/search?q=acc+conductor&biw=984&bih=636&tbm=isch&imgil=GO4MtOIyhvpxkM%253A%253B8\\_Lv2uYY-6oAmM%253Bhttp%25253A%25252F%25252Fsciencepole.com%25252Facc-conductor%25252F&source=iu&pf=m&fir=GO4MtOIyhvpxkM%253A%252C8\\_Lv2uYY-6oAmM%252C\\_&usg=\\_\\_xfUK0LEpNzo2KltZZ3j8p3i5Ilk%3D&dpr=1&ved=0ahUKEwj0mIPjl6rPAhVB5xoKHU54Cc8QyjclTw&ei=P5bnV7T9N8HOa87wpfgM#imgrc=GO4MtOIyhvpxkM%3A](https://www.google.com/search?q=acc+conductor&biw=984&bih=636&tbm=isch&imgil=GO4MtOIyhvpxkM%253A%253B8_Lv2uYY-6oAmM%253Bhttp%25253A%25252F%25252Fsciencepole.com%25252Facc-conductor%25252F&source=iu&pf=m&fir=GO4MtOIyhvpxkM%253A%252C8_Lv2uYY-6oAmM%252C_&usg=__xfUK0LEpNzo2KltZZ3j8p3i5Ilk%3D&dpr=1&ved=0ahUKEwj0mIPjl6rPAhVB5xoKHU54Cc8QyjclTw&ei=P5bnV7T9N8HOa87wpfgM#imgrc=GO4MtOIyhvpxkM%3A)
- [27] [Online]. Available:  
<http://www.panoramio.com/photo/63777760>
- [28] Sag-tension Calculations  
A Tutorial Developed for the IEEE TP&C Line Design Subcommittee  
Based on a CIGRE WG B2.12 - Technical Brochure, June 2005
- [29] ECN General Cable Company Catalogue - [www.ecn.es](http://www.ecn.es)
- [30] [Online]. Available:  
[http://www.oregon.gov/Energy/Siting/docs/Meeting\\_Materials/031513/ItemG\\_Idaho\\_Power\\_presentation\\_031513.pdf](http://www.oregon.gov/Energy/Siting/docs/Meeting_Materials/031513/ItemG_Idaho_Power_presentation_031513.pdf)