

Mobility Robustness in 5G Networks

Ashish Thapliyal

School of Electrical Engineering

Thesis submitted for examination for the degree of Master of
Science in Technology.

Espoo 12-08-2016

Thesis supervisor:

Olav Tirkkonen

Thesis advisor:

Tommi Jokela

Author: Ashish Thapliyal

Title: Mobility Robustness in 5G Networks

Date: 12-08-2016

Language: English

Number of pages: 9+49

Department of Communications and Networking

Professorship: S-72

Supervisor: Olav Tirkkonen

Advisor: Tommi Jokela

5G is the 5th Generation of Mobile telecommunication system. 5G networks will cater to the needs of very diverse user equipment, from millions of stationary sensors per square kilometer to bullet trains running at over 500 km/h. Presence of users with such varied mobility requirements entails us to build a robust mobility architecture for 5G.

Two of the important requirements for 5G networks are a lower latency and a higher reliability than in existing generations of mobile networks. To accomplish the above mentioned use cases and requirements of 5G networks, the mobility solutions and their robustness become a very critical part of 5G. In this thesis we have studied the existing LTE networks, and keeping them as a baseline, tried to find solutions for mobility robustness in 5G networks.

The thesis discusses Mobility State Estimation (MSE) enhancements for dual and multiconnectivity. Analysis of mobility problems in using only one instance of mobility state for a multi-link, multi-layer connected UE are quantitatively analysed and a solution, which uses a MSE instance for each link in multi-link connectivity, is proposed.

Other mobility robustness topic that the thesis focuses upon is improvements in handover failure recovery mechanism, which can also be used for radio link failure in general. The thesis proposes a solution for re-establishment of RRC connection in 5G by using the RRC Connection Suspend and RRC Connection Resume procedure of Narrow Band Inter of Things (NB-IoT).

Keywords: 5G, Mobility, Mobility State Estimation, Dual Connectivity, Handover Failure, Radio Link Failure

Acknowledgement

This thesis is done as a part of Nokia's 5G research project.

Foremost, I would like to express my sincere gratitude to my supervisor Prof. Olav Tirkonnen for his motivation, patience, immense knowledge and insightful comments which guided me throughout this work. I would also like to thank my instructor Mr. Tommi Jokela as well as Mikko Saily, who patiently, enthusiastically and smilingly clarified all my doubts. I would also like to thank my Handover Control team, Jari Sahinoja and Tarja Hiltunen from Nokia, who always supported and encouraged me during my thesis work.

I would also like to thank my parents, Mrs. Beena Thapliyal and Mr. U.S. Thapliyal, rest of my family and friends, for their love, understanding and inspiration. Last, but not the least, I owe a debt of gratitude to my wife Neha, for without her, I would not be able to make it.

Espoo, 12-08-2016

Ashish Thapliyal

Contents

Abstract	ii
Acknowledgement	iii
Contents	iv
Abbreviations	vi
List of Figures	viii
List of Tables	ix
1 Introduction	1
1.1 Motivation	1
1.2 Objective of the Thesis	3
1.3 Structure of the Thesis	3
2 Background	5
2.1 Cellular Network and its Evolution	5
2.2 Heterogenous Cellular Network	9
2.3 5G RAN Architecture	10
2.4 Dual Connectivity and Multi Connectivity	12
2.5 Mobility State Estimation	15
2.6 RRC Connection Re-establishment	19
2.7 RRC Connection Suspend and Resume Procedure	22
2.8 Basic Definitions	25
3 Mobility Robustness Problems in Current Cellular Networks	29
3.1 Handover region and Use of MSE	29
3.2 Dual and Multi Connectivity and MSE	32
3.3 Providing means to fulfill "Mobility on Demand"	35
3.4 Optimization needs for re-establishment of radio connection	35
4 Mobility Robustness Enhancements	37
4.1 Dual or Multi MSE	37
4.2 The need for a new MSE State	39
4.3 Re-establishing a RRC connection using RRC Resume Procedure	39
5 Conclusion	42
5.1 Summary	42
5.2 Future Work	43
References	44

A Appendix	48
A.1 Mobility Parameters for RRC Connected States	48
A.2 Speed Dependent reselection parameters in RRC_IDLE State	49

Abbreviations

2G	2nd Generation of Wireless Telephone Technology
3G	3rd Generation of Wireless Telephone Technology
3GPP	Third Generation Partnership Project
4G	4th Generation of Wireless Telephone Technology
5G	5th Generation of Wireless Telephone Technology
16-QAM	16-ary Quadrature Amplitude Modulation
64-QAM	64-ary Quadrature Amplitude Modulation
AIV	Air Interface Variant
BLER	Block Error Rate
BTS	Base Transceiver System
CCCH	Common Control Channel
CE	Control Element
CS	Circuit Switched
CN	Core Network
C-RNTI	Cell- Radio Network Temporary Identifier
DL	Downlink
DRB	Data Radio Bearer
EDGE	Enhanced Data Rates for GSM Evolution
eNB	e-UTRAN Node B
E-UTRA	Evolved Universal Terrestrial Radio Access Network
FDMA	Frequency Division Multiple Access
GERAN	GSM EDGE Radio Access Network
GSM	Global System for Mobile communications
HOF	Hand Over Failure
HSPA	High Speed Packet Access
IMT	International Mobile Telecommunications
ISD	Inter Site Distance
ITU	International Telecommunication Union
KASME	Local Master Key in EPS
KeNB	Key eNB, an intermediate Key at eNB Level
Krrcint	Key RRC Integrity Protection
LTE	Long Term Evolution
MAC	Medium Access Control
MAC-I	Message Authentication Code for Integrity
MeNB	Master eNB
METIS	Mobile and wireless communications Enablers for the 2020 Information Society
MIMO	Multiple Input Multiple Output
MME	Mobility Management Entity
mMTC	Massive Machine Type Communication
mmW	Millimetre Wave
MSE	Mobility State Estimation
NAS	Non Access Stratum
NB-IoT	Narrow Band Internet of Things

NCC	Next Hop Chaining Counter
NGMN	Next Generation Mobile Networks
NH	Next Hop parameter in E-UTRAN
OFDMA	Orthogonal Frequency Division Multiple Access
PDCCCH	Physical Downlink Control Channel
PDCP	Packet Data Convergence Protocol
PS	Packet Switched
RAN	Radio Access Network
RLC	Radio Link Control
RLF	Radio Link Failure
RNC	Radio Network Controller
RRC	Radio Resource Control
RSRP	Reference Signal Received Power
RTT	Round Trip Time
SCH	Shared Channel
SC-FDMA	Single Carrier Frequency Division Multiple Access
SeNB	Source eNB or Serving eNB or Secondary eNB
SINR	Signal to Interference Ratio
SRB	Signalling Radio Bearer
TDMA	Time Division Multiple Access
TeNB	Target eNB
TR	3GPP Technical Report
TS	3GPP Technical Specification
TTT	Time to Trigger
UE	User Equipment
UICC	Universal Integrated Circuit Card
UL	Uplink
UMTS	Universal Mobile Telecommunications System
UTRAN	Universal Terrestrial Radio Access Network
V2V	Vehicle to Vehicle communication
V2X	Vehicle to Infrastructure communication
VoLTE	Voice over LTE
WCDMA	Wideband Code Division Multiple Access
WLAN	Wireless Local Area Network

List of Figures

1	Cisco's estimate of mobile data traffic growth rate [2]	1
2	5G requirements [4]	2
3	Voice Vs Data [8]	7
4	LTE Architecture	8
5	Example of a Heterogeneous Network	9
6	5G use cases [27]	10
7	5G State Model [30]	11
8	UL DL Imbalance issues in HetNet [19]	12
9	Basic illustration of Dual Connectivity and Single connectivity UEs [19]	13
10	High level sketch of Dual connectivity showing how the data streams from CN might be divided at Macro and small cell [20]	14
11	Dual Connectivity User plane architecture of 1A [19]	14
12	Dual Connectivity User plane architecture of 3C [19]	15
13	Multiconnectivity Scope for 5G [21]	16
14	No scaling of parameters [26]	18
15	Scaling of parameters Treselection [26]	18
16	Scaling of parameters Treselection and Qhysteresis [26]	19
17	RRC Connection Re-establishment in LTE	21
18	RRC Connection Resume Procedure	23
19	Preparation of short MAC-I	24
20	Handover Region at cell border [35]	29
21	UE's handover or cell reselection with respect to Small cell and Macro cell	33

List of Tables

1	Handover region of different pairing of cells for pathloss exponent 3.76	31
2	Time to cover the handover region with different UE speed	31
3	Traffic Model	34
4	Radio Link Failure Interruption time and User Experience [32]	36
5	Comparison of legacy RRC Connection Re-establishment procedure of LTE with RRC Connection Resume procedure of 5G, when used for re-establishment of RRC connection	41

1 Introduction

The objective of this thesis is to find mobility robustness solutions for 5G networks. This introductory chapter first explains the motivation for this thesis and then briefly details about the objective of the thesis and concludes with outlining the structure of the thesis.

1.1 Motivation

Mobile technology has been growing with a rapid rate in the recent years. To put the numbers into perspective, mobile broadband connections will steadily increase in its global base from 40% in 2014 to 70% in 2020. It is estimated that from 2015 to 2020, 2.9 billion new smartphone connections will fuel the growth of mobile telephony. With the advent of new services and applications, the data traffic is going to see a tenfold increase from 2015 to 2019 [1]. In 2015, mobile data traffic globally increased by 73%. In the last decade mobile data traffic has grown 4000 times and in the last 15 years it has grown 400 million times [2]. In short, the need for more speed, ubiquitous coverage, and better quality is continuously growing. Figure 1 shows Cisco's estimate of mobile data traffic growth by 2020.

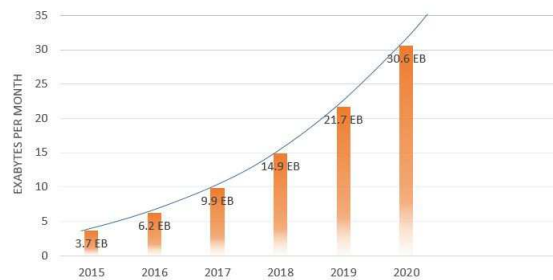

Figure 1: Cisco's estimate of mobile data traffic growth rate [2]

Mobile communication, as a technology, has also been evolving continuously to meet these demands. From analog signalling in 1st generation of mobile communication to the latest Long Term Evolution (LTE) or 4G technology, the telecommunication industry is trying to keep up the pace with the growing demand from the subscribers. So, Global System for Mobile communications (GSM), Universal Mobile Telecommunications System (UMTS), High Speed Packet Access (HSPA), and LTE are already in the field now. The development of LTE-Advanced, the evolution of 4G, is in the process of field trials and early rollouts [3].

Moreover, the definition of user equipment is not limited to traditional mobile phones anymore. A whole new set of devices are emerging on the horizon which will be connected to mobile networks. With the advent of massive machine type communication (mMTC) as well as Vehicle to infrastructure (V2X) and Vehicle to

vehicle (V2V) communication, the number of connected devices will increase manifold. Interestingly, these all devices come with very different sets of requirements.

For example, the main focus area for V2V communication is ultra-reliability and low latency, on the other hand for mMTC devices the focus is not so much on reliability or latency but on power efficiency. The requirement for mMTC devices is such that these devices should last for more than 10-15 years without their battery getting drained.

Figure 2 shows these diverse requirements and the devices that need them:

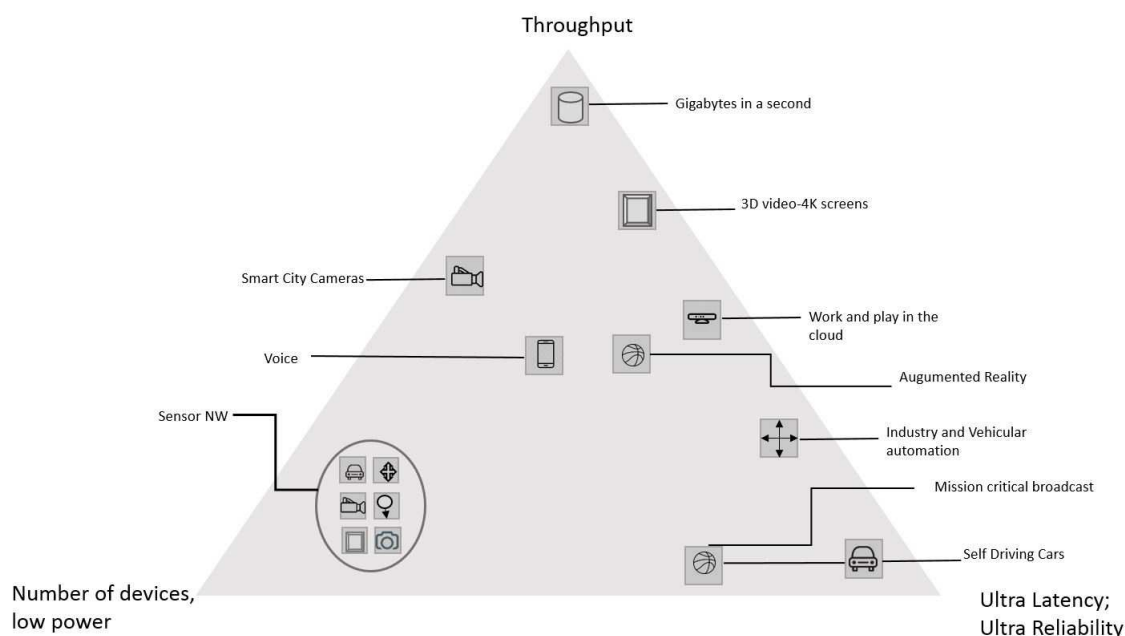

Figure 2: 5G requirements [4]

Such diverse requirements have increased the challenges for the future mobile communication. Hence the need for a new mobile communication system, with even more enhanced capabilities than existing systems seems pertinent [3]. The expectation is that this 5th Generation (5G) system should be able to fulfil the above mentioned three most important requirements, i.e., throughput in the the scale of Gbps, virtually zero milli-second latency, and millions of devices per square Kilometre.

Previous mobile communication generations were mainly driven by higher system capacity and better spectral efficiency. 5G in contrast will be driven by network densification. Network densification was considered part of earlier generations of mobile communication as well, not as a design concept but as an add on feature [5]. Densification of the network is needed to cater to the high throughput and extremely low latency demands of 5G. The main idea is to let the access points be closer to

the users. By doing so, the Round Trip Time (RTT) of the radio will reduce and the network throughput will increase as data can be handled locally by many sub networks created by these small cells. Small cells are expected to provide most of the data traffic by 2020 [6].

With these Ultra Dense Networks (UDN), one of the challenges will be to meet the above mentioned requirements such as ultra-reliability and low latency when the user is moving. A moving user's radio signals changes such that the user gets better signals from the cell it is about to enter (also called Target Cell) than the cell which it is about to leave (also called Serving Cell).

The user's radio resources should be moved from the source cell to the target cell in such a way that the user gets uninterrupted service or has the illusion of uninterrupted service. This process is called Handover in literature. Handovers become a problem when the user is moving fast, because the network gets very little time to execute the handover of the UE from source cell to target cell. When the cell sizes are small, like in ultra-dense networks in 5G, this problem will become very prominent. 3rd Generation Partnership Project (3GPP) has already acknowledged this problem with their study item on Mobility performance in Heterogeneous Network [7].

1.2 Objective of the Thesis

As discussed in the previous section, network densification will bring its own drawbacks in the 5G network. Not only the handovers will become more frequent, but also the time to execute them will be reduced. As a result, mobility in 5G is an important research topic. The research work in this thesis is aimed at studying mobility in 5G networks. The aim is to come up with methods and procedures which will make the mobility in 5G robust.

The two mobility topics, which this thesis concentrates on, are Mobility State Estimation Enhancement and Radio Link Failure Enhancement. The thesis first evaluates the problems in the current mobility state estimation method by performing a quantitative analysis. Based on the finding of this analysis a solution is provided that will enhance the current algorithm. Another topic that is the focus of this thesis is the latency and robustness in radio link failure. For this purpose, existing radio link failure procedure in LTE is examined and then a solution is proposed that aims to reduce the latency in radio link failure scenarios in 5G networks.

1.3 Structure of the Thesis

The thesis has been organized into five Chapters. Chapter 2 starts with a brief overview of cellular networks and their evolution. It is envisioned that 5G will be an amalgamation of different wireless technologies such as LTE and Wireless Local

Access Networks (WLAN), and it will also be a network having cells of various sizes. Accordingly, moving further in Chapter 2, there is a brief introduction to Heterogeneous Networks. Next, 5G Radio Access Network (RAN) architecture is discussed. This is followed by an introduction to Dual Connectivity and Multi Connectivity. Chapter 2 continues with a discussion of different proposed architectures for Dual connectivity in LTE. The discussion then moves to Mobility State Estimation and how it affects the mobility decisions in existing networks, with LTE as an example. Radio Resource Control (RRC) Connection Re-establishment procedure is explained briefly as the next subtopic. The discussion then moves to explanation of RRC Connection Suspend and Resume procedure. At the end of Chapter 2, a brief list of basic definitions, used extensively in this thesis, is provided.

Chapter 3 discusses the problem statements for which this thesis tries to find solutions. The first section discusses the problem of Mobility State Estimation with Dual Connectivity and Multi Connectivity architecture. The next section discusses the need of a new Mobility State Estimation parameter and the chapter concludes with the discussion on need for latency improvement for handover failure/radio link failure scenarios in 5G networks.

Chapter 4 discusses the solutions proposed for the problems discussed in the earlier chapter. The advantages of the dual mobility state estimation are discussed through an quantitative analysis and advantage of the use of the RRC Resume procedure in re-establishment of RRC connection is analysed considering latency improvements.

Chapter 5 concludes the thesis. It discusses the conclusions drawn from this thesis work and also discusses, in brief, the potential future works.

2 Background

This Chapter prepares the foundation for this thesis. It starts by giving a historical introduction of cellular networks and then goes on to explain the building blocks on which this thesis is based.

2.1 Cellular Network and its Evolution

A cellular network comprises of a Radio Access Network (RAN) and a Core Network (CN). The Radio Access Network is the part which implements the access technology. The multiple access technique in GSM is Frequency Division Multiple Access (FDMA), and Time Division Multiple Access (TDMA), in UMTS it is Wideband-Code Division Multiple Access (W-CDMA) and in LTE (4G) it is Orthogonal Frequency Division Multiple Access (OFDMA) and Single Carrier - Frequency Division Multiple Access (SC-FDMA). The Core Network is the switching centre, the link of RAN to the outside world like Internet and Public Switched Telephone Network.

The RAN comprises of User Equipment (UE), Base Transceiver Stations (BTSs) and also sometimes controller devices that control these BTSs, e.g., Base Station Controllers (BSCs) in GSM and Radio Network Controllers (RNCs) in UMTS. The BTS enables the wireless connection between the UE and the Radio Network. A Base Station is also the network entity that creates the "cell" in the cellular network. A typical base station has many transceivers so that the base station is able to serve varied frequencies in a cell.

A base station serves one or more cells. Because the base station is power limited, it can serve only a limited area, hence the frequency that the base station is using can be re-used in another base station. Since 3G, this re-use factor of frequency is 1 i.e. all the neighboring base station can use the same frequency.

As described above, the Core Network is a switching centre and it is the gateway for the RAN towards the outside network. The Core Network routes user sessions between RANs and other networks. Other important functions of Core Network are, billing, authentication and call control.

The first predecessors to mobile telephone systems were launched in 1946 by Bell Labs. These systems used transmitters which had very high power and analog FDMA techniques. The coverage was around 50 miles and there were only very few customers due to bandwidth constraints.

To overcome this bandwidth problem, Bell labs invented the cellular concept. The 1st Generation of mobile networks, which used this cellular concept, were introduced in Nordic countries around the late 1970s. These systems were analog in nature. Examples of 1G systems are Nordic Mobile Telephone (NMT), Advanced Mobile Phone System (AMPS) and Total Access Communication System (TACS).

This "cellular" concept was later shortened to "cell". The name was coined because of the way the signals are handed over between towers. The network itself is distributed into areas called cells.

The inefficiency of analog, non-global 1G system led the development of 2G mobile networks. 2G systems were launched in late 1980s and early 1990s. Data services with low bitrates were supported in conjunction with voice calls.

If we compare the second generation of mobile networks with the first generation of mobile networks, the main difference is that second generation systems were using digital multiple access technologies. 2G technologies are divided into Time Division Multiple Access (TDMA) and Code Division Multiple Access (CDMA) depending on the multiplexing used by the system.

Even with 2G telecommunication systems, multiple standards were used worldwide for mobile communications. Some standards were only used in one region or in one country and were incompatible with each other. GSM emerged as the most successful family of 2G mobile networks. It is estimated that more than 80% users of 2G are on GSM. GSM was first commercially launched in Finland in 1991.

The data handling capabilities for 2G mobile systems were limited. So the Third Generation systems were needed to provide high bit rate services that enable high quality images and videos to be transmitted and received and to provide the access to the web with high data rates [11].

With the meeting of World Administrative Radio Conference (WARC) in 1992, the development of 3rd Generation of cellular systems started. WARC was an International Telecommunication Union (ITU) technical conference and in 1993, its name was changed to World Radio Conference (WRC). It was decided that frequencies around 2000 MHz can be used for 3G systems.

The 3G systems were called International Mobile Telephony 2000 (IMT-2000) within ITU. Several technologies were defined within IMT-2000 for 3rd generation of mobile telephony, the most prominent of those were:

- IMT- DS, Direct Sequence. Also known as W-CDMA or UTRA-FDD, used in UMTS
- IMT-MC, Multi-carrier, Also known as CDMA 2000, the successor of 2G CDMA (IS-95)
- IMT-TD Time-Division TD-CDMA and TD-SCDMA

UMTS was the most prominent of all these technologies. UMTS was an evolution of GSM. The core network was not changed drastically but the main change was in the air interface.

UMTS air-interface used W-CDMA (Wideband Code Division Multiple Access). The 5MHz bandwidth was chosen because it was sufficient for providing 384Kbps speed, which was one of the requirement of IMT 2000. In addition, the wide carrier bandwidth of W-CDMA offered increased multipath diversity [11].

Commercially UMTS network was first opened in Japan in early 2000-2001 and in Europe it was launched around 2002. In 2004, more UEs that support W-CDMA were launched to market and that was the timeframe when we could say that UMTS was really operable.

As can be seen from the Figure 3, the trend in the traffic was skewed more heavily towards data traffic than towards voice traffic. So the work on a new technology started as early as in 2004 (even before the commercial release of HSPA services). This led to the discussions in 3GPP on the new radio technology or 4G.

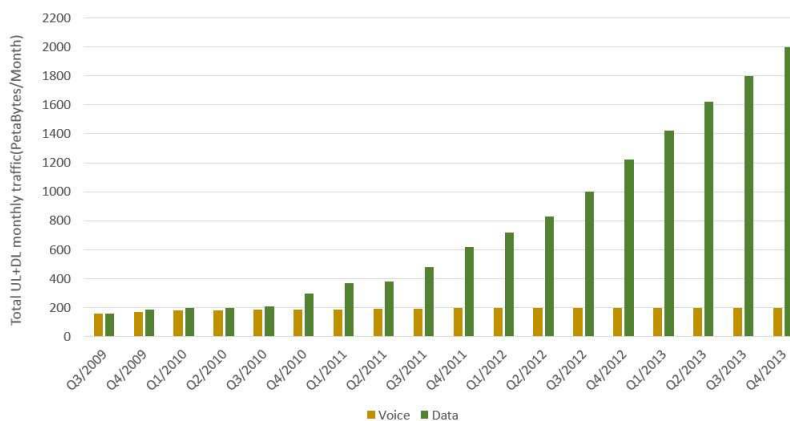

Figure 3: Voice Vs Data [8]

International Mobile Telecommunication - Advanced (IMT- Advanced) is a concept document for mobile technologies beyond IMT-2000. IMT-Advanced from ITU required the following from the 4G networks:

- An all IP based system
- A system which is interoperable with existing wireless standards.
- Data rate (peak) of 100 Mbps for users with high mobility and a peak data rate of 1Gbps for low mobile users.
- Scalable channel bandwidth requirements.
- Seamless connectivity and global roaming.

Only two candidates were submitted against these requirements for IMT-Advanced. Those were Worldwide Interoperability for Microwave Access (WiMAX) and LTE.

LTE specifications were developed by 3GPP and WiMAX specifications were developed by the WiMAX Forum. LTE is the more popular of the two standards and further discussion has its focus on LTE.

LTE uses OFDMA for downlink and SC-FDMA for uplink. There are few important aspects of OFDMA that makes it so important. They are following [13]:

- Robust against Inter Symbol Interference (ISI) effectively.
- Good spectral properties.
- Network capacity can be increased by increasing the carrier bandwidth.
- Low complexity receiver implementation.

With the evolution of the air interface, it became clear very soon that that the system architecture also needs to be evolved. The consensus towards optimizing the system for packet services was one of the strongest reasons for an evolution of the system architecture. As macro-diversity gains were not relevant for LTE, the centralized controller was not needed, which led to a flat architecture. All the functionality related to communication over air were moved to eNB, which is the transmitting and receiving network node [10]. The LTE architecture is depicted in Figure 4.

The main reason for moving to an all IP network was to provide the same platform for all new technologies and also to harmonize the experience of the user [12].

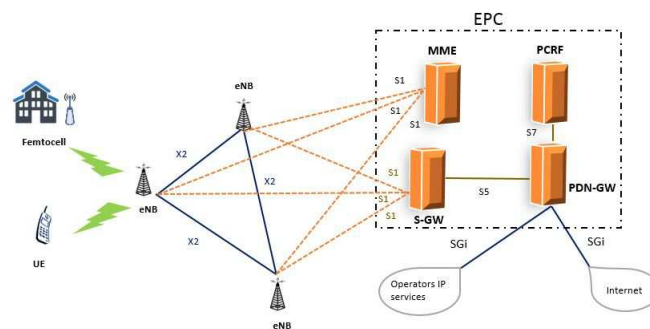

Figure 4: LTE Architecture

The first commercial launched LTE network was opened by TeliaSonera in Stockholm as well as in Oslo in late 2009. LTE release 8 reached a peak data rate of 150 Mbps

in DL and 50 Mbps in UL with 2*2 MIMO and 16QAM in UL. With 4*4 MIMO the speed in DL could go to theoretical maximum of 300 Mbps in DL and 75 Mbps in UL with 64 QAM [13]. LTE later evolved into LTE- advanced with release 10 onwards. The DL speed is predicted to be 1 Gbps and UL to be 500 Mbps.

2.2 Heterogenous Cellular Network

As discussed in Section 1.1, the data rate over cellular network is seeing an exponential growth. The number of mobile data subscribers is increasing and the services which need very high bandwidth are competing for the same radio resources.

Operators have been trying to keep pace with this steep growth of data by improving upon the radio access capability of current sites by the addition of new radio spectrum, multi antenna techniques and more efficient modulation techniques [14] [15].

However, at some point in future the capacity offered by above mentioned evolved radio access will not suffice the need of the users. One alternative path, to meet this demand of huge capacity, is the densification of the network [14].

Addition of various kind of small cells and integrating them tightly with the macro sites will help in maintaining performance, balance the load of the network and improve the quality of service while efficiently re-using the spectrum. The primary reason for adding small cells is to increase the capacity of the networking hot spots and also to improve the coverage, for example, at cell borders or at some blind spots. Such mix of small cells and macro cell is called Heterogeneous Network or HetNet. Figure 5 is an example of HetNet containing femto cells, remote radio heads, and pico cells within a macro cell site.

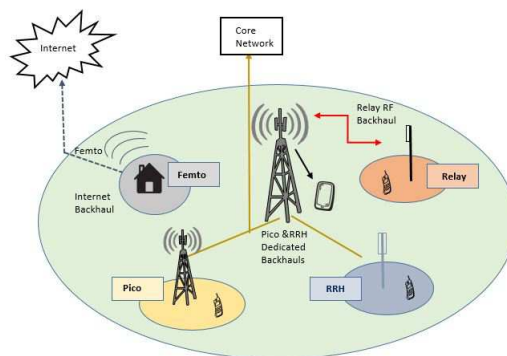

Figure 5: Example of a Heterogeneous Network

HetNets are considered one of the most promising approach to improve the capacity

of the telecommunication networks. Apart from the capacity of users in small cells, user performance in macro cell also improves when small cells are used to fill the coverage holes in macro cells [18].

2.3 5G RAN Architecture

The key service types for 5G as defined in [27], [28], [29] are:

- Extreme Mobile Broadband (xMBB): It is forecast that 3GPP would support user's experienced data rate up to Gpbs level and peak data rate up to tens of Gpbs. The traffic volume in an area could be around Tbps per square Kilometer.
- Massive Machine Type Communication (mMTC): It is forecast that billions of network enabled devices will require wireless connectivity. These devices will consist, among other things, such low power devices whose battery life is estimated to be 10-12 years.
- Ultra-reliable/Critical machine type Communication (uMTC): The use cases like e-health services or critical infrastructure communication require ultra-reliable communication. End to end latency for few of these services may be very low and reliability very high.

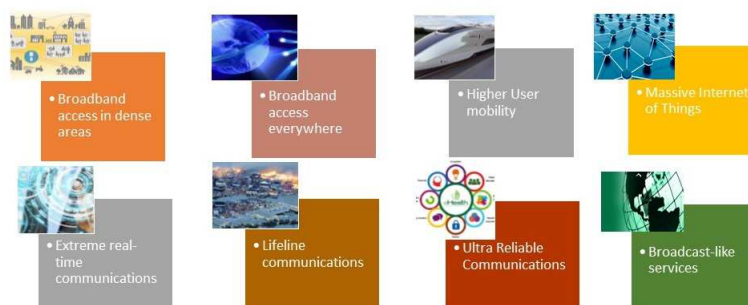

Figure 6: 5G use cases [27]

Based on these service types, METIS-II has derived requirements for 5G RAN. Some of those requirements are [29]:

- Scalability of 5G RAN: Scaling to extremes is one of the key 5G design requirements.
- Native support of multiconnectivity and device to device communication.
- Future proof: 5G RAN should be designed such that it is future proof which means that new features and requirements could be added to 5G efficiently.
- Energy Efficiency: RAN design of 5G should be energy efficient.
- 5G should be able to operate on a wide spectrum range.

5G use cases, as shown in Figure 6, are developed by NGMN, and are grouped into eight families [27].

To fulfil these diverse requirements of 5G, for example, data rates of the scale of Gbps, latency of the scale of few milliseconds, and battery power efficiency, it is proposed that 5G Radio Access Network will have one more state as compared to LTE, called “Connected Inactive” [29]. The proposed state model for 5G RAN is shown in Figure 7.

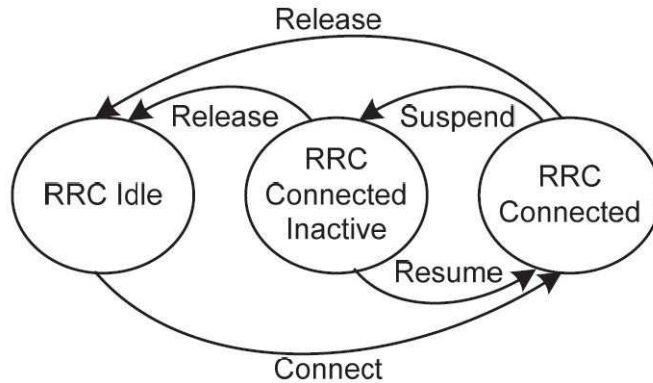

Figure 7: 5G State Model [30]

The most frequent state transition in this 5G RAN state model is foreseen to be from RRC_CONNECTED to RRC_CONNECTED_INACTIVE. It is predicted that state transition from RRC_IDLE to RRC_CONNECTED will happen only during the initial access or later only as a fall back case when the network could not keep the call in RRC_CONNECTED or RRC_CONNECTED_INACTIVE [29].

The RRC_CONNECTED to RRC_CONNECTED_INACTIVE state transition is predicted to be most frequent state transition in 5G, as mentioned above. Accordingly this state transition should be kept lightweight and fast [29]. To achieve this, the RAN will keep the UE context when the UE makes a transition to RRC_CONNECTED_INACTIVE. The S1 connection (see Figure 4) will be maintained. When the UE wants to resume the call in RRC_CONNECTED again, UE resumes with a "resume ID", which is provided when the connection is suspended. It is assumed that network will have the context of the UE. This makes the transition from UE's sleeping state (RRC_CONNECTED_INACTIVE) to RRC_CONNECTED fast as the network does not need to set up a S1 connection. As the network already has the UE's context, the RRC Resume procedure can be a very lightweight procedure.

2.4 Dual Connectivity and Multi Connectivity

Although HetNets, discussed in Section 2.2, promise several benefits, they come with their own problems. Increased number of cells will increase the number of cell boundaries, hence an increase in cell (re-)selection and handovers. This will lead to higher signalling overhead. There is a significant difference in transmit power of small cells and macro cells, which will cause Uplink/Downlink power imbalance for UEs. For example, a cell which is not the serving cell for a UE may be the best Uplink cell for the UE.

In Figure 8, macro eNB's DL received power at the UE is depicted in green. Pico eNB's DL received power at the UE is depicted in grey. UE's UL received power at the macro eNB is depicted in purple. UE's UL received power at the pico eNB is depicted in yellow. At UL cell border the received UL power from the UE is same at the two eNB, whereas at the DL cell border the DL signal power from the both the eNBs is the same at the UE. As can be seen from the figure that between UL cell border and DL cell border UE is in UL/DL imbalance i.e. the best UL and the best DL cell for the UE are different.

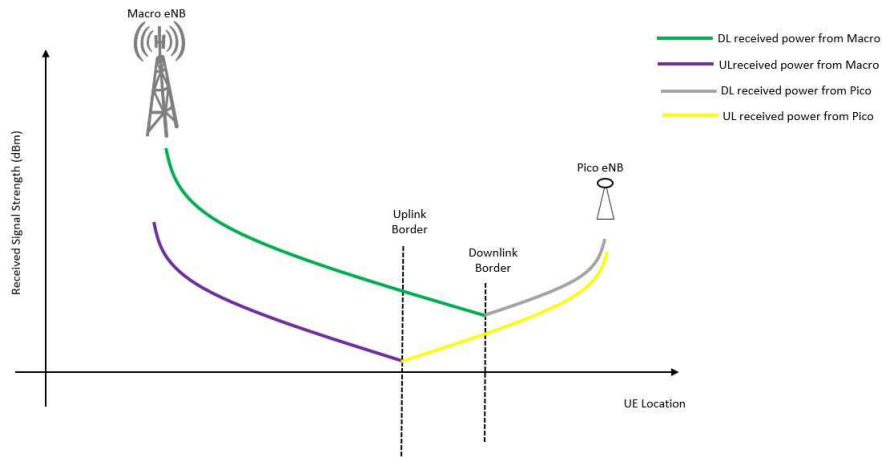

Figure 8: UL DL Imbalance issues in HetNet [19]

The high difference between the transmit power of small cells and macro cells may have a significant impact on performance of UEs near the cell edges. For example, it will impact the handover failure rates and also increase the ping-pong rates (rapid handover back and forth between two cells). So, a new architecture for HetNet scenarios which would mitigate these problems was envisioned [16].

Densification in co-channel deployment of small cells might cause much interference. One simpler approach used for densification of network is to deploy small cells at a

different frequency than macro cell. In 3GPP release 12, a new network architecture with split Control and User plane was introduced. In this architecture the Control Plane and User Plane are not necessarily handled by the same network node. So, small cells can be used to increase the capacity of users at hot-spots and macro cells are used to enhance the coverage. This kind of dual connectivity systems enhances the system performance as macro cells mostly handle the Control Plane messaging like mobility and paging and it may be possible for small cells to sleep for longer time, if there is no user which needs high capacity [16]. The macro eNB in a dual connectivity scenario is termed as Master eNB (MeNB) and the small cell's eNB is termed as Secondary eNB (SeNB).

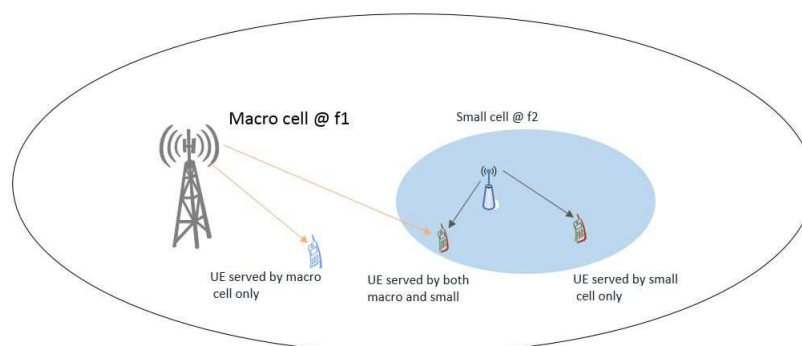

Figure 9: Basic illustration of Dual Connectivity and Single connectivity UEs [19]

This kind of architecture means that Control and User plane signalling might not be transmitted from the same network node [16]. Figure 9 illustrates UEs with single and dual connectivity.

Signalling bearer split, which is a concept that means that the Signalling Radio Bearer (SRB) can be split over multiple eNBs, instead of being transmitted from a single eNB, is not supported in LTE yet. In 3GPP several User plane bearer split architectures have been proposed. The agreement was to support two architecture 1A and 3C which are explained in the next paragraphs [17].

Both SeNB and MeNB can carry the same data bearer, split at RAN or they can carry separate bearers split at Core Network. The splitting of bearer can be performed both at downlink and uplink. So UE needs to maintain separate protocol stack for MeNB and for SeNB [17].

The architecture of 1A and 3C is shown in Figure 11 and 12. It can be seen from the figure that in architecture option 1A, bearers are split at S-GW. The MeNB and SeNB gets separate data bearers. In the option 3C of dual connectivity architecture, MeNB receives the S1-u bearer and then splits it between MeNB and SeNB. The UE, as mentioned above, maintains two separate protocol stacks.

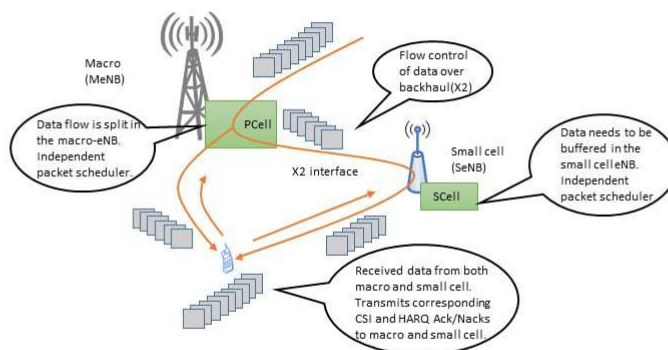

Figure 10: High level sketch of Dual connectivity showing how the data streams from CN might be divided at Macro and small cell [20]

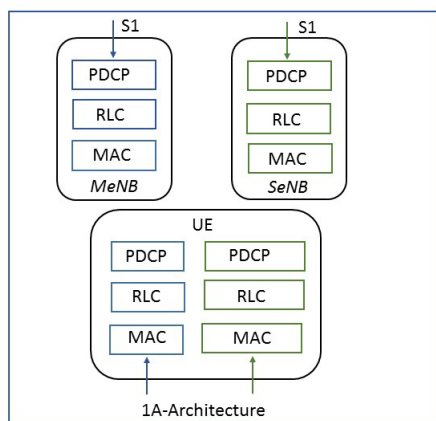

Figure 11: Dual Connectivity User plane architecture of 1A [19]

In 5G, this concept of dual connectivity is extended to multiconnectivity, such that a UE's radio resources might be configured from more than two network nodes. As shown in Figure 13, 5G multiconnectivity will not only focus on aggregating the radio resources from inter frequency cells, such as in Carrier Aggregation (CA) or in Dual Connectivity, but will also include the solutions that include aggregating

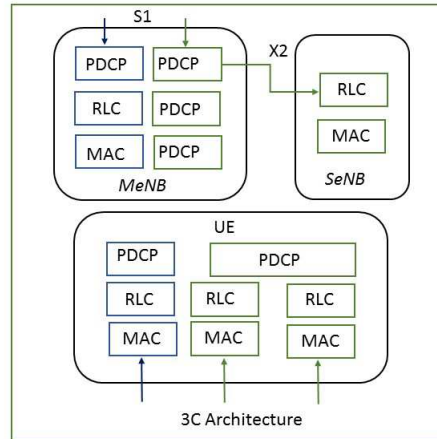

Figure 12: Dual Connectivity User plane architecture of 3C [19]

the radio resources from the cells operating on the same frequency, e.g., Joint Transmission/Dynamic Point Selection Co-ordinated Multipoint (JT/DPS CoMP) and multiflow. Multiconnectivity will inherit LTE dual connectivity specifications as well as develop new features and solutions to meet the very diverse requirements of different 5G use cases. For example, it is foreseen that because of requirements for ultra-reliability and ultra-low latency 5G multiconnectivity will also support Control Plane multiconnectivity [21].

It is envisioned that 5G multiconnectivity will have following capabilities [21]:

- Control Plane multiconnectivity.
- Data duplication support for Ultra-reliable UEs.
- Inter Radio interface optimization.
- Multiconnectivity support for high frequency bands.
- Enabling more multiconnectivity options.

2.5 Mobility State Estimation

LTE supports UE's moving with varying speeds. The UE can be anything from a pedestrian walking on sidewalks to a passenger in a bullet train which is moving at more than 300 km/h. Hence, the handover and cell change procedures also need to adapt to such varying UE speeds.

The RRC in LTE has two states `RRC_IDLE` and `RRC_CONNECTED`. The mobility is UE controlled in `RRC_IDLE` state and network controlled in `RRC_CONNECTED`

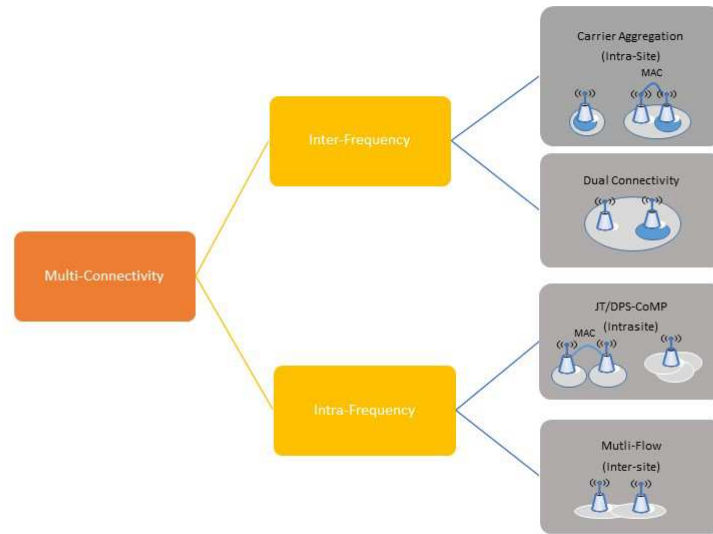

Figure 13: Multiconnectivity Scope for 5G [21]

state of LTE [22]. This means that in RRC_IDLE state UE makes the decision for cell selection or re-selection and updates the network. But in RRC_CONNECTED state the network makes the decision for handovers, based on UE's measurement reports and other criteria like admission control, cell load etc.

Mobility State Estimation (MSE) is a method specified for LTE where the number of handover or cell reselection events defines the UE mobility state for RRC Connected and RRC Idle modes respectively. According to 3GPP TS 36.304 [25], a UE can be in three mobility states based on the number of cell selections (in RRC_IDLE State) or number of Handovers (in RRC_CONNECTED state):

- Normal Mobility State
- Medium Mobility State
- Fast Mobility State

The algorithms to calculate MSE in RRC_CONNECTED are given below [21]. In these algorithms,

n-CellChangeHigh is the number of cell changes that is needed to enter the mobility state High.

n-CellChangeMedium is the number of cell changes that is needed to enter the mobility state Medium.

```

TimeInterval ← t-evaluation
if NumberOfHandover ≥ n-CellChangeHigh then
  UE'sMobilityState ← High
else
  if NumberOfHandover ≥ n-CellChangeMedium then
    UE'sMobilityState ← Medium
  else
    UE'sMobilityState ← Normal
  end if
end if

```

Based on the calculated mobility state of the UE, the parameter such as **TimeToTrigger** (TTT), time for reselection (**Treselection**) and hysteresis margin **Qhyst** are scaled. The basic idea is that to avoid ping-pong handover, the UE triggers handover only after the RSRP of the target cell is above the RSRP of the source cell by some offset and for some predefined time interval. This offset is called hysteresis margin and this predefined time interval is called **TimeToTrigger** (TTT). This point, where RSRP of target cell is above the RSRP of source cell by **Qhyst** for a predefined time interval TTT, is shown as point B in the Figure 14.

sf-High and **sf-Medium**, in the algorithm below, are the scaling factors which are multiplied with the mobility parameters to scale the value of these parameter. According to 3GPP TS 36.331 [24], the values that **sf-High** or **sf-Medium** can take are 0.25, 0.5, 0.75 or 1.0.

```

if UE'smobilitystate = n-CellChangeHigh then
  TimeToTrigger ← TimeToTrigger × sf-High
else
  if UE'smobilitystate = Medium then
    TimeToTrigger ← TimeToTrigger × sf-Medium
  else
    TimeToTrigger ← TimeToTrigger
  end if
end if

```

These mobility parameters, such as, *t*-evaluation, *t*-hystNormal, *n-CellChangeHigh*, *n-CellChangeMedium*, and **TimeToTrigger** are explained in the Appendix A.1 [23].

In RRC_IDLE state the logic is analogic with a different time window and different parameters that are scaled. The parameters related to RRC_IDLE state are explained in Appendix A.2

The figures 14, 15, 16 show how a change in mobility state of a UE can affect the scaling of certain handover parameters and how this scaling effects the cell reselection

procedure [26]. Cell re-selection in this scenario happens when the equation, $\text{RSRP of target cell} - \text{RSRP of source cell} \geq Q_{\text{hyst}}$, is satisfied for a predefined time period $T_{\text{reselection}}$.

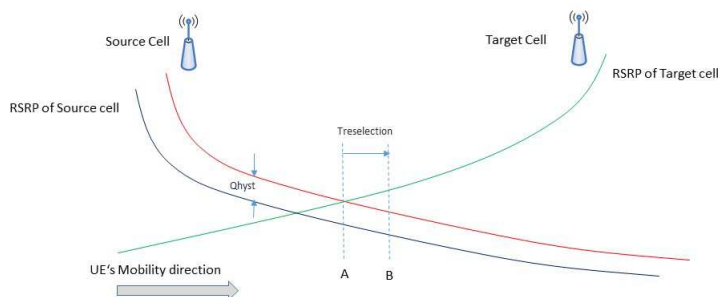

Figure 14: No scaling of parameters [26]

Figure 14 shows the scenario when no scaling is used. RSRP of target cell becomes better than RSRP of source cell by Q_{hyst} at point A. UE waits for a time period $T_{\text{reselection}}$ and after that at point B in the figure, the UE triggers cell re-selection.

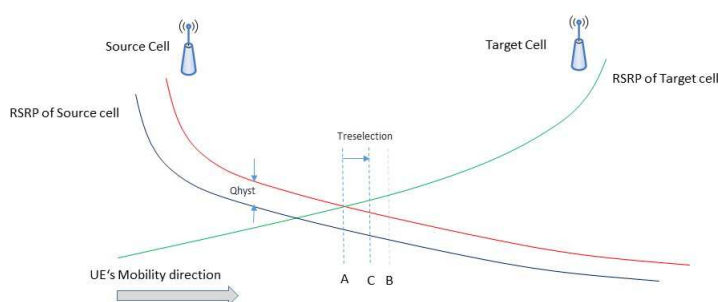

Figure 15: Scaling of parameters $T_{\text{reselection}}$ [26]

Figure 15 shows the scenario when the UE is either in High or Medium mobility state and scaling only for **Treselection** is used. RSRP of target cell becomes better than RSRP of source cell by **Qhyst** at point A. The value of the parameter **Treselection** is scaled, so instead of triggering cell reselection at point B, UE triggers cell re-selection earlier at point C in the figure.

Figure 16 shows the scenario when the UE is either in High or Medium mobility state and the value of the parameter **Qhyst** is scaled together with **Treselection**. The equation for triggering cell re-selection now becomes, $\text{RSRP of target cell} - \text{RSRP of source cell} \geq \text{Qhyst (scaled)}$. So, in Figure 16, reselection is triggered much earlier at point D.

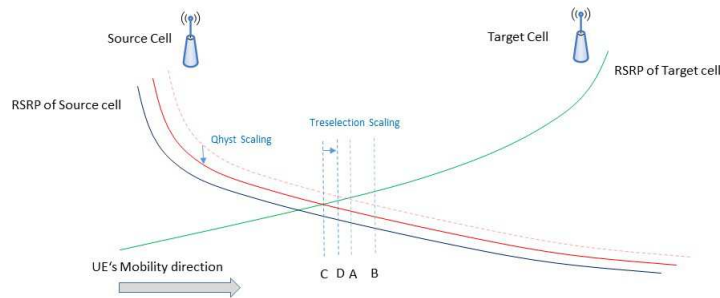

Figure 16: Scaling of parameters **Treselection** and **Qhysteresis** [26]

The main advantage of scaling the mobility related parameters, like **Treselection**, **Qhyst** or **TimeToTrigger**, is that it facilitates faster execution of mobility procedure for UEs that are moving with high speeds. A UE, which is fast moving, should be facilitated such that it can trigger handovers earlier than UEs which are slow moving, otherwise fast moving UE would have entered deep inside the boundaries of target cell before the handover signalling is completed. This would cause radio link failure or handover failure. There is a trade-off between handover failures and ping pong handovers.

2.6 RRC Connection Re-establishment

RRC Connection Re-establishment procedure, in a 3GPP cellular network, is performed because of radio connection failures, such as UE losing the radio connection with the network. It is used to re-configure Signalling Radio Bearers (SRBs) and to re-activate the security. SRBs are the bearers that are used to carry RRC and

Non Access Stratum (NAS) messages. Three SRBs are defined for LTE network. SRB0 is used to transfer messages which use the Common Control Channel (CCCH). SRB1 is used to transfer messages which use the Dedicated Control Channel (DCCH). SRB2 is used to transfer low priority RRC messages and Non Access Stratum (NAS) messages. Data in LTE is carried using Data Radio Bearers (DRBs).

Possible reasons for re-establishing a RRC connection are:

- Radio Link Failure
- RLC Unrecoverable Error
- Handover Failure
- RRC Connection Reconfiguration Failure

LTE uses RRC Connection Re-establishment procedure to re-configure SRB1 and re-activate security and RRC Connection Reconfiguration procedure to setup SRB2 and DRBs and hence, bring the UE back to the same state where it lost the RRC connection. The signalling is depicted in Figure 17.

After the RRC connection is lost in LTE, the UE initiates a RRC Connection Re-establishment procedure to set up SRB1. As shown in Figure 17, RRC Connection Re-establishment procedure consist of these 3 messages (message numbered 1,2,3):

- RRC connection re-establishment request
- RRC connection re-establishment
- RRC connection re-establishment complete

LTE security, which includes ciphering and integrity protection, is re-activated after RRC Connection Re-establishment procedure is complete. SRB2 and DRBs are set up only after the radio connection is secure i.e. once the ciphering and integrity protection are established over the radio connection. SRB2 and DRBs are set up by using the RRC Connection Reconfiguration procedure which consist of these two messages:

- RRC connection reconfiguration
- RRC connection reconfiguration complete

During RRC Connection Re-establishment procedure, either the last Serving eNB (last Serving eNB or SeNB is the eNB with which the UE had the last radio connection) prepares the Target eNB (Target eNB or TeNB is the eNB to whom UE's radio connection is being transferred) by sending the UE context or the TeNB may fetch the UE context from SeNB by sending UE ID to the SeNB.

To communicate with the RAN, UE needs four security keys: Krrcint, Kupenc, Kenb, and Kasme. These keys are not transferred over the air.

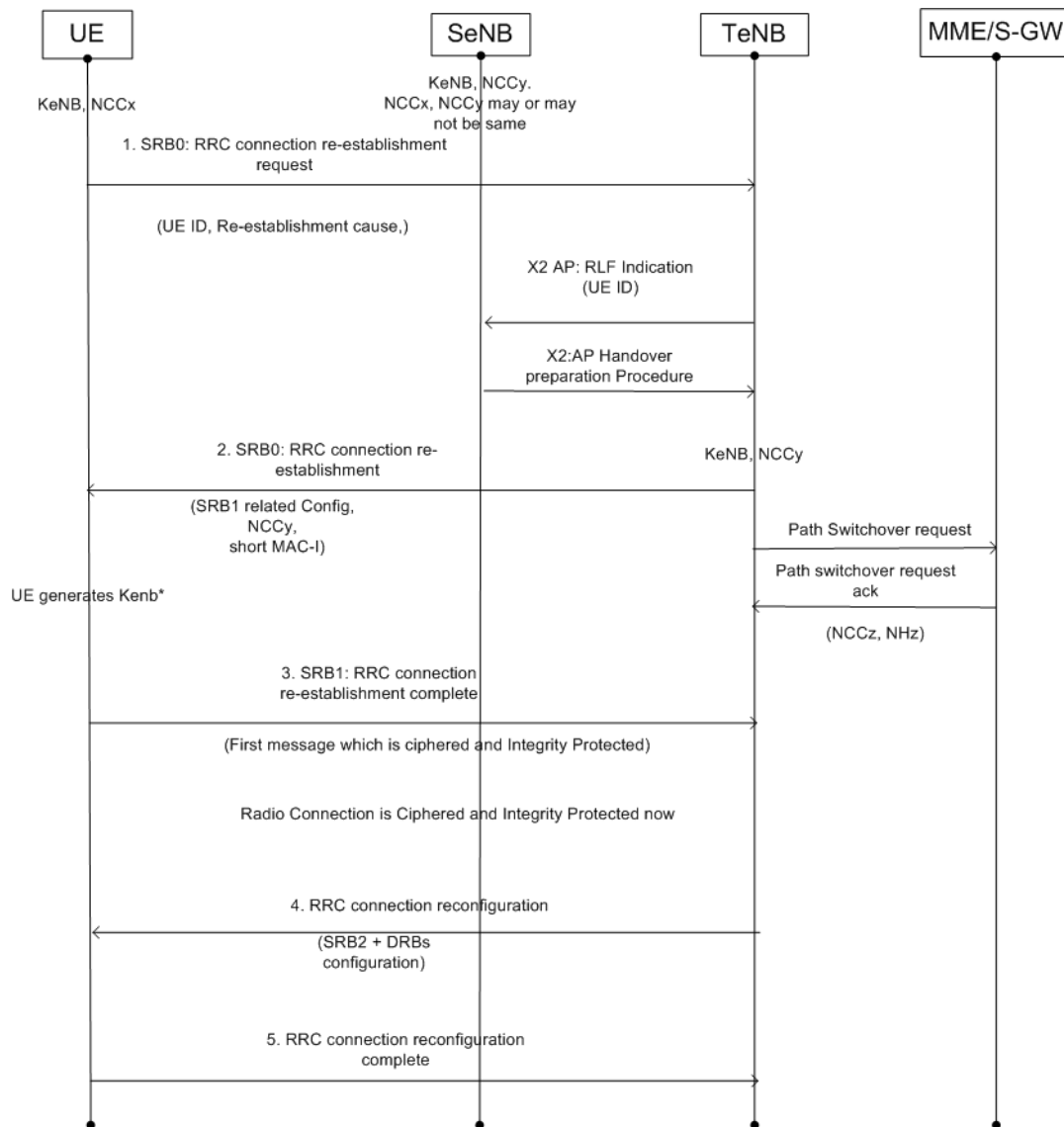

Figure 17: RRC Connection Re-establishment in LTE

- Krrcint is used for integrity protection.
- Kupenc is used for ciphering user plane data.
- Kenb is used to derive Kupenc and Krrcint.
- Ksme is used to derive Kenb and is present only in UE and Core Network.

At the time of radio link failure, the UE and the SeNB share the same keys. To re-establish the lost RRC connection, UE and Target eNB needs new set of keys to communicate with each other. The derivation and usage of these keys in RRC Connection Re-establishment procedure is the same as the usage of these keys in RRC Resume procedure (Section 2.7).

During the RRC Connection Re-establishment procedure, the UE will derive the new Kenb by using Next Hop Chaining Count (NCC) value, which is sent to UE in RRC connection re-establishment message, thereby deriving new keys for ciphering and integrity protection. The RRC Connection Re-establishment procedure and its security handling is explained in [24] and [37].

2.7 RRC Connection Suspend and Resume Procedure

RRC Connection Suspend and RRC Connection Resume procedure in 5G will be used for state transition from RRC_CONNECTED_INACTIVE to RRC_CONNECTED state and vice versa [29], [30]. In 3GPP specifications, these procedures are still not defined in detail for 5G. However, these procedures in 5G are inspired from RRC Connection Suspend and RRC Connection Resume Procedure that are being developed for NB-IoT [29], [30]. So, in this thesis when we refer to these procedures, we take the definition of the messages from NB-IoT's RRC Connection Resume procedure.

RRC Connection Suspend procedure is initiated by E-UTRAN. All the existing UE's radio bearers except SRB0 and SRB1 are suspended, when UE receives the message to suspend the RRC connection from RAN. UE context information, which contains the security keys of the RRC connection and the information related to bearers, is stored in the eNB. The resume ID is the index for this UE context information in the network. E-UTRAN provides the resume ID to the UE either during or before the suspension of the RRC connection.

The resumption of RRC connection is initiated by UE through RRC Connection Resume procedure. The resumption of the connection succeeds only if the UE context is found in the eNB. The RRC Connection Resume procedure contains these messages:

- RRC connection resume request
- RRC connection resume
- RRC connection resume complete

The RRC Connection Resume procedure, shown in Figure 18, is explained below.

1. At the time when UE receives the message from RAN to suspend the RRC connection, UE and last serving eNB have the same Kenb. UE suspends all RBs except SRB0 and SRB1.
2. UE makes a transition to RRC_CONNECTED_INACTIVE State.
3. When the UE has to resume the RRC connection, UE does a cell search and finds a suitable cell in TeNB. UE sends RRC connection resume request message to TeNB.

The RRC connection resume request message contains:

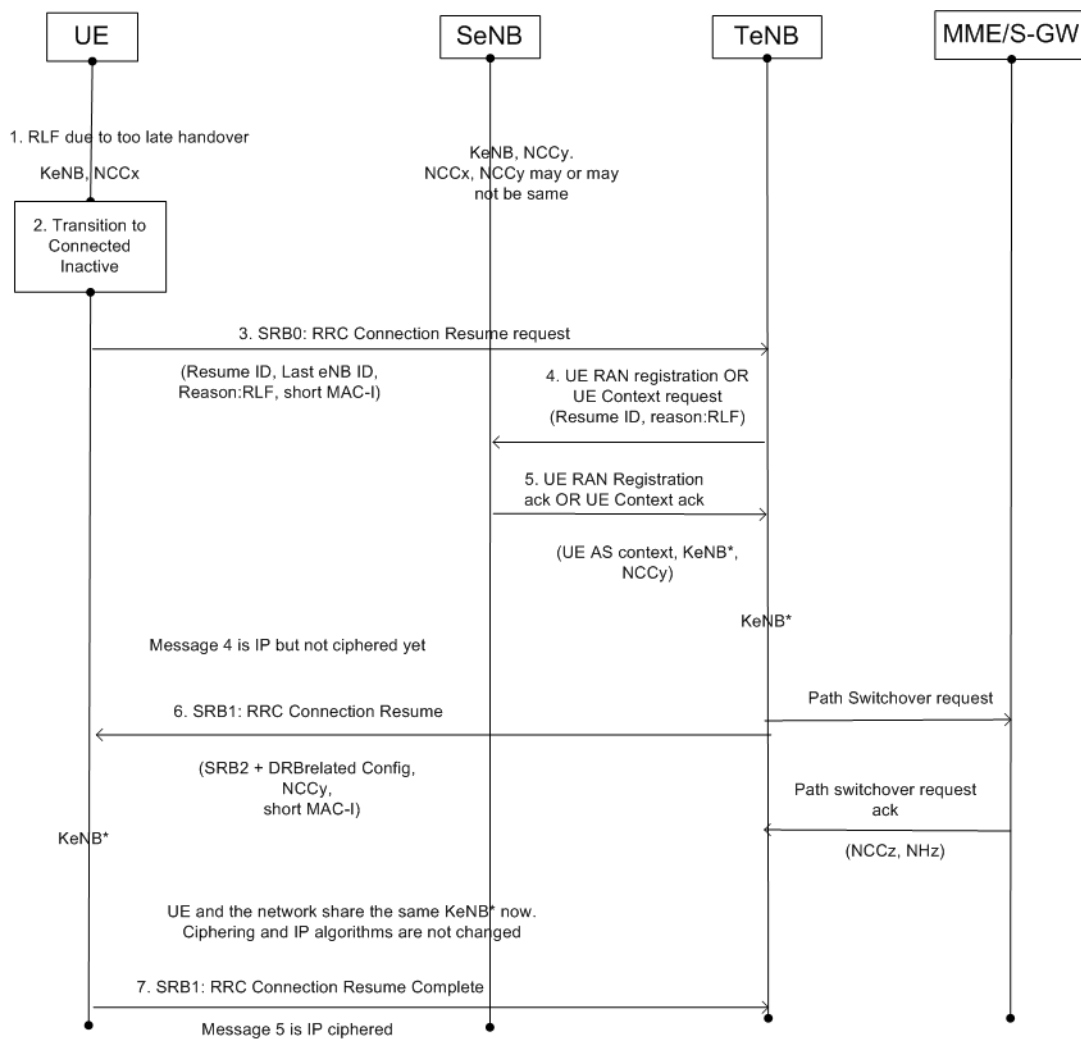

Figure 18: RRC Connection Resume Procedure

- Resume ID.
- RRC connection resume reason.
- Last serving eNB-ID (either as a part of Resume ID or as a separate entity).
- Short MAC-I (Message Authentication Code for Integrity Protection). This MAC-I is prepared using last $KeNB, KRRCint$.

Short MAC-I is calculated as shown in Figure 19:

The value of BEARER, COUNT and DIRECTION are always set to '1'. This means that with the same $KeNB$ and $KRRCint$, MAC-I will always have the same value.

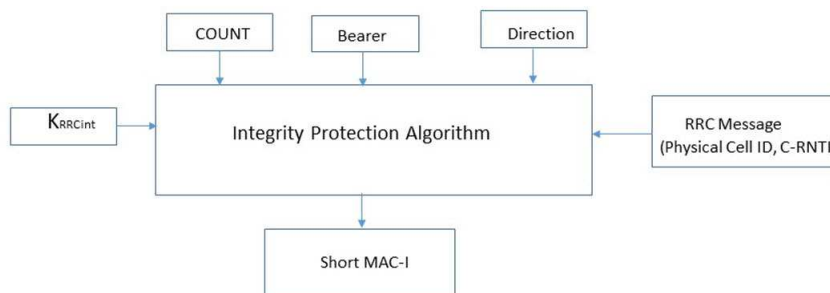

Figure 19: Preparation of short MAC-I

To make MAC-I more robust, for the same eNB and UE, the C-RNTI should change with every RRC Resume procedure [33].

The RRC resume request message will contain the last received C-RNTI as part of the resume-ID (or C-RNTI needs to come separately in the message) and this is the only freshness in the computation of MAC-I, in subsequent computations.

4. As the MAC-I in the RRC connection resume request message is prepared using last serving eNB's Keys (KeNB and Krrcint), only the last serving eNB can authenticate this message. So, either the TeNB, which receives the RRC resume request message, will forward this message to the last serving eNB or during context transfer, last serving eNB can transfer this short MAC-I information also to the TeNB.

TeNB recognises the last serving eNB from last serving eNB-ID (or from the resume ID, depending on how resume ID is prepared) and requests the UE context from the last serving eNB (and also will pass the short MAC-I) by X2 messaging.

5. The last serving eNB shall locate the UE context using the resume ID. It will compute the short MAC-I using KeNB and Krrcint from this UE's context and validate the received RRC connection resume request message comparing the short MAC-I received in X2 message from TeNB and the computed short MAC-I.

If the short MAC-I matches, last serving eNB sends the UE context to TeNB. Last serving eNB also prepares the KeNB* using horizontal key derivation [37], similar to X2 handover, and passes it to the TeNB.

6. From the received KeNB*, TeNB prepare new Krrcint and Krrcenc. TeNB sends RRC connection resume message on SRB1. This message is integrity protected

in PDCP layer using the new keys, but is not ciphered. Ciphering cannot be started at this point because the UE has not derived the new keys and hence will not be able to decipher the message.

The RRC connection resume message contains:

- short MAC-I prepared using new KeNB* and new Krrcint.
- NCCy – To help UE to calculate KeNB*
- SRB2 and DRB related configuration.

Due to admission control few of the radio bearers might even be dropped. The admission control in TeNB would select all or a subset of bearers that should be resumed at the UE. The UE shall remove any bearer that has not been resumed. The TeNB should also inform the CN or last serving eNB about bearers that are resumed and removed (in path switchover request or through signalling over X2 in case the last serving eNB remains the anchor for this connection).

7. When the UE receives the RRC connection resume message, the UE shall calculate a new KeNB* using NCCy, the target cell's Physical Cell Identity and its frequency EARFCN-DL in the target cell. The UE then performs further derivation of the keys (RRC integrity key, RRC encryption key and UP keys) from the new derived KeNB*.

The UE checks the integrity of the RRC connection resume message by verifying the short MAC-I. If the verification of the short MAC-I is successful, then it sends the RRC connection resume complete message, both integrity protected and ciphered, to the Target eNB on SRB1.

Small UL data on DRB(s) can also be sent in RRC connection resume complete message.

2.8 Basic Definitions

This list summarizes the most important concepts that are used in this thesis extensively.

3GPP system: A telecommunication system which adheres to 3GPP specifications. These systems consist of a core network, access networks which may be GERAN, UTRAN, E-UTRAN or some other access networks such as WLAN, and User Equipment.

Access Stratum: A functional grouping consisting of the parts in the infrastructure and in the user equipment and the protocols between these parts being specific to the access technique (i.e. the way the specific physical media between the User Equipment (UE) and the Infrastructure is used to carry information).

Authentication: A property to correctly identify an entity with the required assurance. Various Users, subscribers, networks may be the entity that are identified.

Base Station: A network element in a radio access network responsible for radio transmission and reception in one or more cells to or from the user equipment. A base station can have an integrated antenna or be connected to an antenna by feeder cables.

Bearer: A transmission path through which information can be transferred. The delay, the capacity and the bit error rate for a bearer are pre-defined.

Call: A logical association between several users (this could be connection oriented or connection less).

Cell Radio Network Temporary Identifier (C-RNTI): A UE identifier allocated by a controlling RNC and it is unique within one cell controlled by the allocating CRNC. C-RNTI can be reallocated when a UE accesses a new cell with the cell update procedure.

Cipher key: A code used in conjunction with a security algorithm to encode and decode user and/or signalling data.

Connected Mode: The User Equipment is in the connected mode when it has a RRC connection established.

Connection: A communication channel between two or more end-points (e.g. terminal, server etc.).

Core network: An architectural term relating to the part of 3GPP System which is independent of the connection technology of the terminal (e.g. radio, wired).

Downlink: A unidirectional communication path from the network to the User.

Dual Connectivity: A UE in RRC_CONNECTED is configured with dual connectivity when configured with a Master and a secondary cell group.

E-UTRAN Radio Access Bearer (E-RAB): Uniquely identifies the concatenation of an S1 Bearer and the corresponding Data Radio Bearer.

Handover: The process of transferring the User's connection (voice or data) from one channel to another channel.

Macro cells: The cells which have the largest cell radius in Mobile Communication System. The radius ranges from hundreds of metres to Kilometres.

Medium Access Control: A sub-layer of radio interface layer 2 providing mapping between logical channels and transport channels.

Mobility: The ability of users to communicate while they are moving.

Msg3: Message transmitted on Uplink Shared Channel (UL-SCH) containing a Cell Radio Network Temporary Identifier (C-RNTI) Medium Access Control (MAC) Control Element (CE) or Common Control Channel (CCCH) Service Data Unit (SDU) submitted from upper layers and associated with the User Equipment (UE) Contention Resolution Identity as part of a Random Access procedure.

Paging: A process of waking up the UE and telling it that there is some data available for it.

Protocol: A formal set of procedures that are adopted to ensure communication between two or more functions within the same layer of a hierarchy of functions [9].

Radio access bearer: The service that the access stratum provides to the non-access stratum for transfer of user data between User Equipment and CN.

Radio Bearer: The service provided by the Layer 2 for transfer of user data between User Equipment and UTRAN.

Radio-Leg: In case of Multi-Connectivity, a cell that is configured with resources for a UE.

Radio interface: The tetherless interface between User Equipment and a UTRAN access point. This term encompasses all the functionality required to maintain such interfaces.

Radio link: A logical association between a single User Equipment and a single UTRAN access point. Its physical realisation comprises one or more radio bearer transmissions.

Radio Link Control: A sublayer of radio interface layer 2 providing transparent, unacknowledged and acknowledged data transfer service.

Radio Network Temporary Identifier: A generic term of an identifier for a UE when an RRC connection exists. Example of RNTI: Cell RNTI (C-RNTI).

Radio Resource Control: A sublayer of radio interface Layer 3 existing in the control plane only which provides information transfer service to the non-access stratum. RRC is responsible for controlling the configuration of radio interface Layers 1 and 2.

RRC Connection: A point-to-point bi-directional connection between RRC peer entities on the UE and the UTRAN sides, respectively. A UE has either zero or one RRC connection.

S1: The interface between EPC and eNB. It provides a connection between EUTRAN and EPC.

Security: The ability to prevent fraud as well as the protection of information availability, integrity and confidentiality.

Service Continuity: The uninterrupted user experience of a service that is using an active communication (e.g. an ongoing voice call) when a UE undergoes a radio access technology change or a Circuit Switched/Packet Switched (CS/PS) domain change without, as far as possible, the user noticing the change.

Serving eNB: This is the eNB on which the UE is actually camped which means that it takes care of managing the radio resources for the UE.

Suitable Cell: UE may camp on this cell after satisfying certain conditions.

Target eNB: This is the eNB which is the target for either a handover or for a connection re-establishment.

Uplink: Uplink is defined as unidirectional communication path for the transmission of radio signals from the User to the Network.

User Equipment (UE): Allows a user access to network services. For the purpose of 3GPP specifications the interface between the UE and the network is the radio interface. A User Equipment can be subdivided into a number of domains, the domains being separated by reference points. Currently the User Equipment is subdivided into the Universal Integrated Circuit Card (UICC) domain and the ME Domain. The ME Domain can further be subdivided into one or more Mobile Termination (MT) and Terminal Equipment (TE) components showing the connectivity between multiple functional groups.

Uu: The Radio interface between UTRAN and the User Equipment.

3 Mobility Robustness Problems in Current Cellular Networks

This chapter introduces the mobility robustness related problems that this thesis tries to solve.

3.1 Handover region and Use of MSE

In Figure 20 below, the green line denotes the source cell's RSRP and yellow line denotes target cell's RSRP. One of the most important decisions that the UE has to take in a cellular network is when to trigger the handover. There is a trade-off between too early handover, causing ping-pong handovers and too late handovers causing radio link failure.

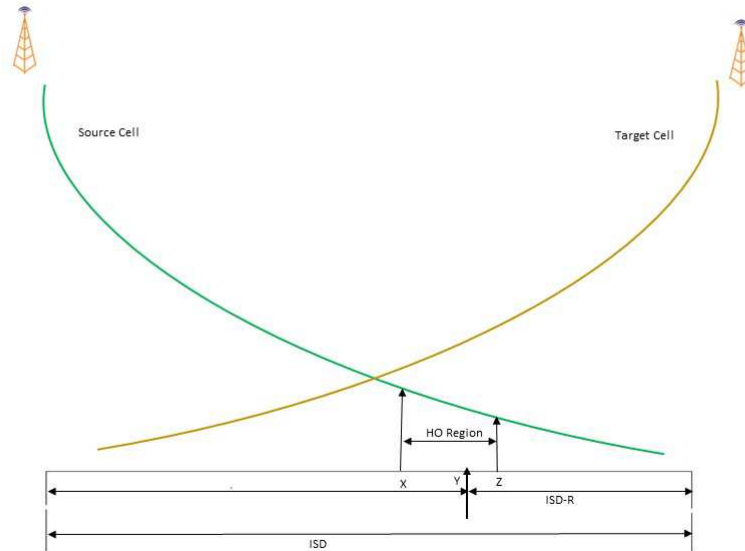

Figure 20: Handover Region at cell border [35]

If Block Error Rate (BLER) on Physical Downlink Control Channel (PDCCH) is 10% at point Z, then to avoid radio link failure, which is normally calculated as 10% BLER on PDCCH [38], UE should be able to finish handover before point Z. The reason for this is that after point Z, UE has entered very deep inside the target cell and cannot decode the signals from the source cell, hence UE declares radio link failure.

If X is the point in the Figure 20 where the RSRP of the target cell is above the RSRP of the source cell by an offset and for a time period TTT, then the area between

point X and point Z is called the handover region. Now, for a successful handover, the handover procedure should be completed in handover region.

Calculation of handover region δR ($R_z - R_x$):

We first consider the scenario where both the source and target cell are a macro cell. The measurement event that is being referred for this analysis is event A3. Event A3 is triggered when the neighbour cell becomes offset better than the serving cell [24]. The variables used in this analysis are explained below:

A3offset: The offset used in event A3 that is added to the serving cell to make the serving cell measurements look better than its actual value.

Qin: Threshold for PDCCH BLER outage.

In this analysis hysteresis values for serving cell and neighbor cells are not considered.

Qin, **A3offset** and Path loss values are taken from the generic 3GPP traffic models [7]. ISD for the Macro-Macro and Pico-Pico scenario has been taken from [35].

The parameter values for Macro-Macro scenario are:

$$ISD = 500m, \quad Qin = -6dB, \quad A3offset = -3dB \quad (1)$$

We use the standard 3GPP pathloss model:

$$PL = 128.1 + 37.6 \log_{10} R \quad (2)$$

The received power at the UE is

$$P_{rx} = P_{tx} - PL \quad (3)$$

For the Source Cell in the handover region the received power at the UE is thus:

$$P_{rx-source} = P_{tx-source} - PL \quad (4)$$

Similarly the received power of the Target Cell in the handover region can be given by the equation

$$P_{rx-target} = P_{tx-target} - PL, \quad (5)$$

where the distance from the target cell to the UE is calculated as ISD-R.

SINR at any location A is given by:

$$SINR_A = P_{rx-source} - P_{rx-target} \quad (6)$$

SINR at point X and Z in the handover region in the figure is given by equation 1

$$SINR_x = -3db, SINR_z = -6dB \quad (7)$$

The distance from the serving base station of the point X and Z by using the above equations comes out to be:

$$R_x = 273.22m, R_z = 295.42m \quad (8)$$

So handover region for a Macro-Macro scenario with ISD = 500 m is thus

$$\delta R = R_z - R_x = 22m.$$

For Pico-Pico scenario, the corresponding parameters are

$$ISD = 125m, \quad Qin = -6dB, \quad A3offset = -3dB \quad (9)$$

Following the same steps as for Macro-Macro scenario, we get:

$$R_x = 68.3\text{m}, R_z = 73.96\text{m}$$

So the handover region for a Pico-Pico scenario with $\text{ISD} = 125\text{m}$ is $\delta R = R_z - R_x = 5.6\text{m}$.

The results are summarized in Table 1:

Source-Target	Handover Region(m)	ISD(m)	Ratio of ISD to HO Region
Macro-Macro	22	500	22.7
Pico-Pico	5.6	125	22.3

Table 1: Handover region of different pairing of cells for pathloss exponent 3.76

The time taken by UE to cover the handover region is not only dependent on time to trigger and hysteresis value but also on UE speed.

Table 2 shows the handover time taken by UE's of speed 3 km/h, 30 km/h, 40 km/h, 60 km/h and 120 km/h to cover the handover region of Table 1:

Source-Target	3 km/h	30 km/h	40 km/h	60 km/h	120 km/h
Macro-Macro	26 s	2.6 s	1.9 s	1.3 s	0.7 s
Pico-Pico	6.7 s	0.7 s	0.5 s	0.3 s	0.2 s

Table 2: Time to cover the handover region with different UE speed

Handover should be triggered earlier for faster UEs compared to slower UEs, as faster UEs stay in handover region for a considerably shorter time than slow moving UEs. The data in Table 2 attests to this fact.

It is also clear from the Table 2 that handover should be triggered earlier for Pico-Pico, scenario compared to Macro-Macro scenario as the handover region for Pico-Pico scenarios is very small compared to Macro-Macro scenario.

It is also evident that if the UE is fast moving and the handover involves a Pico cell then the need for triggering early handover becomes even more critical because with faster speed and reduced handover region, the time taken by the UE to cover this handover region is very small. The above result is also confirmed from [39]. It is specified in [39] that as the UE speed increases, the need for scanning inter frequency cells should also increase because it becomes critical that small cells are discovered earlier for such high speed UE to perform handover before a RLF happens.

Mobility State Estimation of UE tells the relative speed of UE with respect to cell changes or handovers, i.e. how frequently the UE is changing its serving cell. Mobility

State Estimation gives the option of scaling up the time to trigger and hysteresis values of a cell, if the UE is fast moving, so that handover can be triggered earlier.

If the LTE network knows that UE's Mobility State Estimation is either medium moving or fast moving then the network passes the scaling factor `sf-High` and `sf-medium` to the UEs i.e. the factor by which the UE will scale some handover parameters if UE detects that the MSE is fast or medium. And by doing so the UE can trigger the handovers or the cell selection a bit earlier as explained in Section 2.5.

For example if UE is fast moving and `sf-high` = 0.2 then if the time to trigger value for a handover in a cell is 500ms and hysteresis value is -3dB, the new time to trigger value and the hysteresis will be multiplied by `sf-high`. So, the new value of these two parameters will be 100ms and -0.6dB respectively.

3.2 Dual and Multi Connectivity and MSE

UE's current Mobility State Estimation is not optimal for dual or multi connectivity. The following section describes the MSE problems in RRC Connected and RRC Connected Inactive State.

RRC_CONNECTED State The Mobility State Estimation of UE is defined for single connectivity UEs i.e. when the UE is connected to only one cell at a time. 3GPP has introduced Dual Connectivity in LTE-Advanced and later, such that, a UE can be connected to two cells simultaneously. In 5G this concept has been extended such that UE might be connected to more than two cells simultaneously and this concept is called multiconnectivity as explained in Section 2.4

The first problem in MSE, as currently used in LTE, is the possibility to use only one MSE instance. Dual connection in LTE is used such that the MeNB is a Macro cell, providing coverage. Usually a lower frequency range is used for this connection. In contrast, the SeNB is a small cell, providing capacity and usually higher frequency range is used for this type of connection. So, even though the UE's speed on ground is the same for both MeNB and SeNB, the need for scaling mobility parameters is different for the two layers.

When estimating the UE speed with MSE, the number of mobility events per time window is correlated with the true speed. The LTE-MSE procedure is not about speed estimation, but correlating the speed with a scaling of mobility parameters.

In Figure 21, the brown line shows an example path that a UE has travelled. For RRC_CONNECTED State, let us suppose that the UE has dual connectivity with the macro cell and small cells on this path. If we assume that the path traced by UE is one time window, `t-evaluation` (as explained in Annex A), for Mobility State Estimation, we can see that the UE has not crossed the macro cell boundary, hence

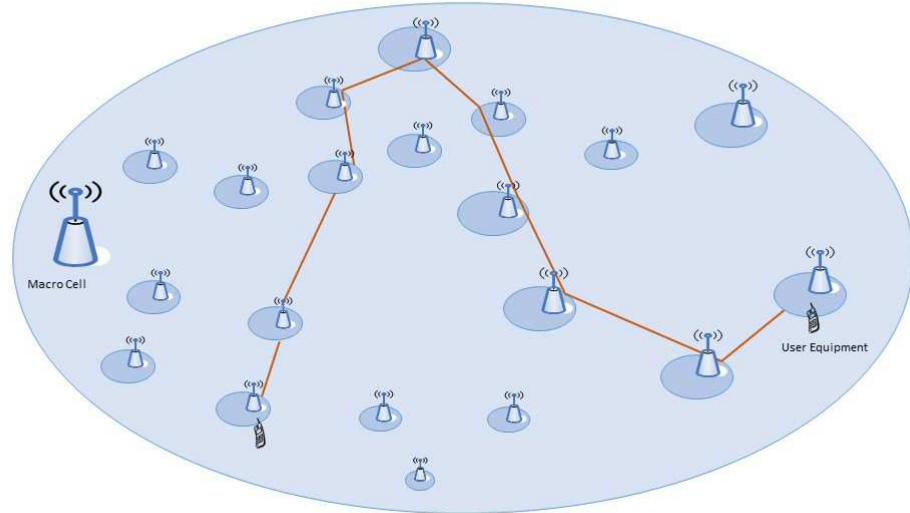

Figure 21: UE's handover or cell reselection with respect to Small cell and Macro cell

macro cell handover or re-selection is counted as one, and hence UE is slow moving with respect to the macro cell.

On the other hand, the number of SeNB changes (addition/deletion/modification) in this example is ten. Thus, the UE is fast moving with respect to the small cell layer. This means that for the UE's path from MeNB to MeNB, handover parameters does not need any scaling, however, for SeNB to SeNB change (addition, deletion, modification) the handover parameters need scaling. If the handover parameters for SeNB to SeNB change are not scaled, the handover procedure may fail.

To get a quantitative understanding, let us take the traffic model defined in [7] and ISD value taken from [35]. From Table 3 the UE is in medium mobility with respect to SeNB i.e. small cell layer and with normal mobility with respect to MeNB i.e. macro cell layer. So, if MSE is calculated by checking macro cell changes only, the Mobility State of the UE is normal.

The time taken to complete handover = Time to trigger + handover execution time
 = 480 ms + 150ms = 630 ms.

From Table 2 we can see that for SeNB (Pico-Pico handovers) with a UE speed of :
 30 km/h, the handover region is covered in 672 ms.
 40 km/h, the handover region is covered in 504 ms.

Handover Parameters	Values
A3 TimeToTrigger	480 ms in normal mobility
TTT scaling factor	0.5 in medium mobility 0.25 in fast mobility
N_CR medium, limit to enter medium mobility in hetnet scenario	10
N_CR high, limit to enter high mobility in hetnet scenario	16
A3 offset	3 dB
Macro Cell ISD	500 m
Handover Execution Time (including preparation time)	150 ms
Qin Threshold	-6 dB

Table 3: Traffic Model

60 km/h, the handover region is covered in 336 ms.

So it is evident that for such UEs, whose speed is more than 30 km/h, in HetNet networks, dual connections will start getting radio link failures for SeNB change. The power consumption in UEs for inter frequency scanning also becomes very high when UE is in high mobility state and is continuously scanning inter frequency small cells [40]. For single connected high speed UEs, it is also suggested that scanning of inter frequency measurement could be switched off or frequency scanning should be made more frequently as time spent in the cell becomes small [40].

From this discussion we can conclude that current usage of MSE is not optimal for dual-connected or multi-connected UEs. For the same UE speed on ground, MSE of the UE with respect to MeNB and SeNB may be different. Because the current LTE-MSE scaling is not taking into account the different mobility parameter requirements for multi-link radio legs of multi-layer mobility, current LTE-MSE scaling may cause too early or too late handovers which might lead to Handover Failures (HOF) and Radio Link Failures (RLF) for SeNBs of dual connections.

RRC_CONNECTED_INACTIVE State This is the low activity sub state of RRC_CONNECTED state. Although from the Core Network's point of view the RRC connected Inactive UEs are part of RRC_CONNECTED state, in this low activity state the mobility decisions are controlled by UE. In this state the UE's will trigger cell selection and reselection, which means that this state is closer to RRC_IDLE than RRC_CONNECTED from Mobility State Estimation point of view. So, it is fair to conclude that this state will need a new set of scaling parameters as compared to RRC_CONNECTED state.

If the UE can go to this low activity state with dual connection, the reasoning

given against the use of single MSE instance above for RRC_CONNECTED state holds for RRC_CONNECTED_INACTIVE state as well. Also, if the UE went to the low activity state with dual connection and if the UE then comes back to RRC_CONNECTED state, the network has no mean to know the MSE of each radio leg of the UE.

3.3 Providing means to fulfill "Mobility on Demand"

From the UE's mobility state estimation, the network cannot determine if the UE is stationary or not. The stationary UEs in this context are the UEs, which have not performed any handover or cell reselection during a pre-configured time.

Mobility on demand is one of requirement of NGMN for 5G [27]. To provide mobility on demand, the network should know if the UE is mobile or stationary.

There is one set of 5G UEs such as UEs in mMTC, for which the network might know, from the UE's capability that these UEs will remain stationary. But for mobile broadband UEs if the network has to differently treat the UEs which are stationary, then the network should have some mean to know if the UE is stationary.

3.4 Optimization needs for re-establishment of radio connection

As per 3GPP TR 25.912, Feasibility study of new Radio [37], 5G systems have very strict latency requirements. The NGMN white paper on 5G [27] says that end users should get the perception of being always connected in 5G, which means that from the perspective of an end user, initial access to the network should be instantaneous, and any recovery from radio link failures should be fast enough to give the UE the perception of being always connected.

A drive test carried out in a Heterogeneous network in a North American city [32] established that for Voice over LTE (VoLTE), handover failure rates are around 22% in the downtown area, and RRC Connection Re-establishment procedure's failure rate for the VoLTE is more than 60%. One of the conclusion from this 3GPP contribution [32] was that failure rate of RRC Connection Re-establishment procedure was high because the TeNB was not prepared. As per 3GPP TS 36.331 [24], RRC Connection Re-establishment procedure will fail if the TeNB is not prepared.

There is a need for some mechanism to bring down the failure rate of RRC Connection Re-establishment procedure. The service interruption duration for re-establishment of RRC connection is one of the problematic areas in LTE. The service interruption time for re-establishment of RRC connection is given in Table 4 [32].

From Table 4, it is seen that the interruption time can be in the range of few hundred milliseconds to few seconds. It would be beneficial if re-establishing the RRC

	Interrup- tion Time (ms)	User Experience
Successful HO and data forwarding	80-100	No user perceivable interruption.
Successful HO, no data forwarding	200-250	User hears "click".
RLF and successful re-establishment	800-3000	User hears cutting of some words above 1 second.
RLF followed by unsuccessful re-establishment and NAS recovery	3000-5000	Unbearable silence for user, it may lead to hanging up of the call.

Table 4: Radio Link Failure Interruption time and User Experience [32]

connection can be made leaner by reducing the time to re-establish the connection and also by sending less bits over air during the re-establishment procedure.

From the discussion in 2.6, we know that to bring the UE back to the state where it lost the RRC connection (Messages number 1 to 5 in Figure 17), the current LTE signalling takes five RRC messages to be exchanged between UE and the network.

The UE context fetching when the TeNB is not prepared was added to LTE after Release 12. So not all LTE releases support that TeNB fetches the UE context, when it was not prepared by the last serving eNB. If the last serving eNB does not prepare TeNB for handover and if the context fetching fails then the RRC Connection Re-establishment procedure is considered as a failure and TeNB commands the UE to move to RRC Idle state and the UE then starts all over again with RRC Connection Setup procedure. Making this transition to RRC_IDLE state and then requesting RRC Connection Setup procedure takes around 3-5 seconds [32], which is a long time.

Most of this delay in re-establishment of RRC connection comes from the expiry of various timers, but reduced signalling over RRC can also help in reducing some part of this delay. Moreover if in 5G networks we can ensure that UE contexts are available always [30], the RLF timer values can be set more aggressively.

4 Mobility Robustness Enhancements

This chapter discusses the solutions that can help in removing the problems that have been discussed in Chapter 3.

4.1 Dual or Multi MSE

As discussed in Section 3.2, if a UE is in dual-connectivity or multi-connectivity mode, the UE's mobility state calculated vis-à-vis macro cell and small cell will be different i.e. the UE will have different mobility for different radio legs. So, there is a need to maintain two or more mobility states for a 5G dual-connectivity or multi-connectivity UE.

By having different Mobility State Estimations for macro and small cells in the dual or multi connectivity the UE gets the option to scale the mobility parameters of macro cells (MeNB) and small cells (SeNB) differently.

The SeNB's mobility state estimation will ensure that the UE with high mobility with respect to small cell, changes the SeNB link optimally i.e. the UE's mobility parameters like Q_{hys} , TimeToTrigger etc. can be scaled up when the UE is seen as fast moving with respect to SeNB, irrespective of UE's speed with respect to MeNB, hence making the SeNB connection robust.

The MeNB's mobility state estimation ensures that the UE's mobility state estimation with respect to MeNB is calculated only based on UE's speed with respect to MeNB, irrespective of its speed with respect to SeNB. So, the same UE, which might have high mobility with respect to SeNB but low mobility with respect to macro cell, gets longer connection with MeNB, hence ensure robustness.

The solution proposed in this thesis, to avoid the problem of dual connectivity and MSE, is to maintain two Mobility State Estimation instances for dual connected UEs. This method is called enhanced Mobility State Estimation or eMSE henceforth in this document. eMSE will correlate the speed estimate with the user velocity using the mobility events, such as cell reselections and handovers for each radio leg of dual connected UE.

The method comprises of following novel elements:

- eMSE will evaluate the UE's MSE per radio leg, which may have connectivity to different radio layers and/or Air Interface Variants (AIV), e.g., macro layer and pico layer, or in 5G the higher carrier frequencies of mm Wave with beam forming physical layer.
- eMSE will scale the handover parameters of different layers depending upon the configuration. The measurement and reporting configuration can have macro

layer parameters optimized for normal mobility but the small cell layer may be consisting of small cells on higher frequency layers which need more aggressive reporting due to abruptly varying radio link conditions.

Advantages of maintaining eMSE:

- The main feature of the proposed solution allows the mobility state of the UE to be tracked using multiple MSE processes instead of one. This comes with the following benefits:
 - Each radio leg (layer) of a multi-connectivity session can be mapped to its own MSE process to allow mobility state differentiation based on properties such as cell size (e.g. macro vs pico), cell density (e.g. UDN vs. clustered hotspots), or link reliability (e.g. low vs. high frequency). This is not possible in the legacy solution that is based on a single MSE process.
 - The differentiated MSE outcomes can be used in RRC active state to scale the UE mobility parameters in a more optimized manner compared to the legacy solution, where a single scale factor is applied to all layers. One example would be the scaling of TTT values based on cell type (e.g. macro overlay/small cell) [24]. Note that, although cell specific scaling of TTT is supported by the legacy solution, it is carried out by the network, implying that the scaling cannot reflect the actual UE movement, but is limited to a common value across all UEs.
- Another embodiment of eMSE is that it allows optimized control of mobility state, when UE is connected to network during the low activity periods. RRC_INACTIVE_CONNECTED state of RRC is the low activity state of the RRC [30] and in this state MSE scaling will resemble to RRC_IDLE state more than RRC_CONNECTED state. So, there is a need of new mobility scaling parameters for this new low activity state. If 5G supports multi layer camping to this new state, then when the low activity period is over, the UE can indicate the cell reselection history of each radio leg to RAN and RAN can update its MSE state.

Let us reconsider the example taken in Section 3.2, Figure 21 with dual MSE implemented. There are 2 MSE instances, one for the macro layer and another for the small cell layer. The UE is in RRC_CONNECTED state.

From MeNB's point of view, the UE is slow moving, so there is no need to scale the mobility parameters of UE. So, from Traffic model in Table 3, for MeNB, the mobility parameter for UE is $TTT = 480$ ms.

From SeNB's point of view the UE is considered to have a "medium" mobility state, as the UE has performed more than 10 SeNB changes. So, the following scaling will

take place on UE's mobility parameters based on traffic model of Table 3: The TTT value is scaled by `sf_medium` (0.5), so TTT becomes $480 \times 0.5 = 240ms$.

From Table 3, the time taken for a UE with speed of 60 km/h to cross the handover region of Pico-Pico configuration (5.6 m) was 336 ms. This scaling of TTT gives the UE enough time to perform handover, hence it increases the robustness of the SeNB connection by guarding against radio link failure.

RRC_CONNECTED_INACTIVE state needs another set of MSE parameters than RRC_CONNECTED or RRC_IDLE. The optimal values of these parameters is not studied in this thesis and it can be a subject of future studies.

If the 5G UE is supporting inter-RAT or inter-AIVs multicell camping, following the same logic as for the RRC_CONNECTED state, eMSE in UE's inactive state is also needed. The UE will have the option of scaling different mobility related parameters based on UE's speed relative to SeNB. Also, when the low activity period of UE is over, the UE can indicate the cell reselection history to RAN and RAN can update its MSE state. If 5G UE is supporting inter-RAT or inter-AIVs multicell camping, the UE history may be reported for each radio leg.

4.2 The need for a new MSE State

To provide "Mobility on demand", as proposed by NGMN white paper [27], the network should have some mean to know if the UE is mobile or stationary. RRC specification for LTE, TS 36.331 [24], already provides three mobility states for UE's which are mobile, i.e. Normal Mobility, Medium Mobility, Fast mobility.

In eMSE it is proposed that there shall be a new mobility state namely "Stationary Mobility" for UE's which are stationary. So if by calculating the mobility state estimation UE comes to the conclusion that it is not mobile, it may report this to the network and the network then may act accordingly.

4.3 Re-establishing a RRC connection using RRC Resume Procedure

By implementing some modifications to RRC Connection Resume procedure that is being proposed for 5G and NB-IoT, this procedure can be used to re-establish a RRC connection in 5G. As RRC Connection Resume procedure is a smaller procedure than currently used procedure for re-establishing a RRC connection in LTE, hence this is faster method and less bits will be transferred over air.

In NB-IoT's RRC Suspend and RRC Resume procedures UE is provided a resume ID when the connection is suspended. However, during a radio link failure, UE's connection is not suspended gracefully, i.e. UE loses the connection with the network instead of network suspending the connection, so UE will not receive the resume ID

from the network.

The modification needed in NB IoT's RRC Connection Suspend and RRC Connection Resume procedure, to use it for re-establishing a RRC connection, is that the UE should have the resume ID provided to it before the suspension of the RRC connection. There are two ways to ensure this:

- UE can be provided the resume ID before the radio link failure happens i.e. resume ID is provided to UE when the UE context is created in the eNB (after or during Security Mode Command procedure), so that even if the RRC connection is not suspended gracefully, such as during a radio link failure, UE can use the resume ID and hence RRC Resume procedure to re-establish the RRC connection.
- UE can prepare the resume ID itself based on the identifiers that UE possess at the time of radio link failure. For example, resume ID can be C-RNTI + Physical Cell ID.

Advantages of using RRC Resume Procedure for re-establishing RRC connection:

1. It will reduce the time taken to complete the re-establishment of a RRC connection, because less signaling is used compared to the original RRC Connection Re-establishment procedure.

The time taken to complete the legacy LTE RRC Connection Re-establishment procedure is $2.5 \times \text{RTT}$ (because 5 messages are exchanged before the radio connection is at the same state as it was before the radio link failure).

The time taken to complete the re-establishment of RRC connection using RRC Connection Resume procedure is $1.5 \times \text{RTT}$ (because 3 messages are exchanged before the radio connection is at the same state as it was before the radio link failure).

2. Signaling overhead in the network will reduce because less messages are exchanged between network nodes for re-establishment of the RRC connection. (5 RRC messages in legacy procedure vs 3 RRC message in the new proposed procedure).
3. As we re-use the same RRC message sequence that is used for RRC Connection Resume procedure for re-establishing the RRC connection, the total number of RRC messages will be reduced. It will ease implementation and also the maintenance efforts.

A comparison of re-establishment of RRC connection using both the legacy RRC Connection Re-establishment procedure and the proposed RRC Suspend Resume procedure can be found in Table 5.

From this comparison it is evident that there are clear benefits of using the new RRC Resume procedure for re-establishing RRC connection in 5G. The disadvantage of

KPI	Using RRC Connection Re-establishment procedure in LTE	Using RRC Suspend Resume Procedure in 5G	Advantages
Analysis of re-establishment of RRC connection in LTE and 5G	Using RRC Connection Re-establishment procedure in LTE	Using RRC Suspend Resume Procedure in 5G	Advantages
Signalling Overhead	5 RRC message to establish all SRBs and the DRBs that were established before RLF.	3 RRC Messages to establish all the SRBS and the DRBs.	40% reduction in RRC signalling (3 vs 5 RRC messages) in 5G. With the proposed 5G architecture, UE context fetching is inherently added to 5G, hence the probability of RRC_CONNECTED to RRC_IDLE transition is further reduced, which will again bring reduction in signalling overhead.
Control Plane Latency	Random Access delay + 2.5 * RTT	Random Access delay + 1.5 * RTT	Compared to LTE, the re-establishment of RRC Connection using the RRC Resume procedure will be reduced by 1*RTT. Less probability of RRC_CONNECTED to RRC_IDLE transition in 5G as RAN will store the UE context for longer time, so the improvement in latency can be still more. Moreover, the radio RTT in this case will not be the same as it will depend on 5G radio frame structure.

Table 5: Comparison of legacy RRC Connection Re-establishment procedure of LTE with RRC Connection Resume procedure of 5G, when used for re-establishment of RRC connection

using the new procedure is that it is less secure than the legacy RRC Connection Re-establishment procedure used in LTE as the SRB2 and DRB configurations are sent without ciphering.

5 Conclusion

This chapter proposes the summary and future work for the thesis. We also discuss the limitations of the work done under this thesis.

5.1 Summary

Considering the ultra-reliability and low latency requirements of some of the UEs in 5G, mobility robustness will be a very important topic in 5G networks. This thesis discussed few topics which will help in improving the mobility robustness in 5G networks.

The first topic that is discussed in this thesis is eMSE. eMSE will improve the mobility of a dual connectivity or multi connectivity UE in a 5G networks. It will help the UE and the network to make better decisions about scaling of handover parameters because UE will have the mobility states of all the radio legs that it is connected with. The macro cell leg of the UE could be kept more robust and the small cell leg could be kept more agile by scaling up the mobility parameters appropriately. Moreover because the handover/re-selection of macro and micro legs do not interfere with the mobility states of each other, the mobility state estimation of each radio leg is a better representative of actual mobility of the UE with respect to each dual connected radio leg.

Mobility on demand is another important topic for 5G. To help in obtaining mobility on demand, the thesis proposes to introduce a new mobility state for UEs, which is called “Stationary” state. As mentioned earlier, it has been found out by mobile operators that only around 30% of the UEs are actually mobile. So, the proposal from mobile operators is that the 5G network should not provide mobility to all the users all the time, but mobility should be available only on demand. For always stationary devices like smart meters, it will be prudent that UE’s mobility related information is embedded in UE’s capability, but for the mobile phones, the UE or network right now does not calculate if the UE is stationary or not. We proposed in this thesis that UE’s current Mobility State should include one more state, “Stationary”. It can be calculated by the UE for example based on the number of UE’s cell selection or handovers during some period of time. If the UE has not changed its cell, the UE or the network can mark the UE as stationary. With this knowledge of UE’s mobility, network can decide what service this stationary UE will need.

Another issue that is discussed in this thesis is usage of RRC Resume procedure for re-establishing RRC connection. It has been proposed that the RRC State Model for 5G will contain one more sub state of RRC Connected State in LTE. The state transition from this new sub state to RRC_CONNECTED state, which is called RRC Resume procedure is similar to LTE’s RRC Connection Re-establishment procedure used for re-establishing RRC connection. We proposed in this thesis the use of RRC Resume procedure for re-establishment of RRC connection. This will reduce the signalling for re-establishing RRC connection, reduce latency and also obviate the

need for a separate signalling for RRC Connection Re-establishment procedure.

5.2 Future Work

From the point of view of this thesis, the most important future work for eMSE proposal would be to simulate it and compare the results against a dual connected UE with a single mobility state.

The proposal for new Mobility State “Stationary” can also be seen as an introduction to Mobility on demand use case. Equipped with this information that the UE is not mobile, there will be plethora of opportunities for the network to optimize its handling for such UEs. A detailed study on neighbour cell optimization or offloading of the stationary UEs, for example to Wireless LAN, would be an interesting study item.

For using the RRC Resume procedure to re-establish the RRC connection, the next step would be to simulate the re-establishment scenario using the RRC Resume procedure and compare its latency against the latency in legacy re-establishment scenario.

From the point of view of 5G, mobility robustness is a vast topic in itself. Other interesting topics like RRC diversity, early warning of radio link failures or handover failures, make before break handover for 5G etc. should be studied in detail to have basic framework ready for mobility robustness in 5G.

The introduction of new RRC_CONNECTED_INACTIVE state in 5G adds new dimension to mobility, as well as, to its robustness in RRC_CONNECTED State. Now the RRC Connected will have both the UE enabled and network enabled handovers. This will also change the way how UE history information is managed in RRC Connected state in 5G systems.

Another important study item in 5G, which will affect mobility robustness, is inherent support of mMTC. The number of devices per square kilometre will increase exponentially. This will impact the mobility and hence mobility robustness. Another important question with mMTC devices is their need for mobility support; what kind of mobility should be supported for such devices.

To conclude, it is fair to say that there are lot of challenges, hence lot of research possibilities in the area of 5G mobility and 5G mobility robustness.

References

- [1] GSMA, *GSMA Global Mobile Economy report 2015*, tech. rep., 2015. Available: http://www.gsamobileeconomy.com/GSMA_Global_Mobile_Economy_Report_2015.pdf
- [2] Cisco, *Cisco Visual Networking Index: Global Mobile data traffic forecast update 2015-2020*, White paper, 2016. Available: <http://www.cisco.com/c/en/us/solutions/collateral/service-provider/visual-networking-index-vni/mobile-white-paper-c11-520862.html>
- [3] NTT-DOCOMO, *DOCOMO 5G White paper: 5G Radio Access: Requirements, Concept and technologies*, White paper, 2014. Available: https://www.nttdocomo.co.jp/english/binary/pdf/corporate/technology/whitepaper_5g/DOCOMO_5G_White_Paper.pdf
- [4] Nokia, *5G Use Cases and requirements*, White paper, 2014. Available: <http://resources.alcatel-lucent.com/asset/200010>
- [5] A.Gotsis, S.Stefanatos and A.Alexiou, "*Ultra Dense network: The new wireless Frontier for enabling 5G access ?*", IEEE Vehicular Technology Magazine, vol.11, no.2, pp.71-78, June 2016. Available: <http://arxiv.org/pdf/1510.05938v1.pdf>
- [6] Nokia, *Looking ahead to 5G: Building a virtual zero latency gigabit experience*, White paper, 2014. Available: <http://resources.alcatel-lucent.com/>
- [7] 3GPP, *Mobility enhancements in heterogeneous networks*, TR 36.839, V11.1.0, 2012. Available: <http://www.3gpp.org/dynareport/36839.htm>
- [8] Ericsson, *Ericsson Mobility Report*, White paper, 2013. Available: <https://www.ericsson.com/res/docs/2013/emr-august-2013.pdf>
- [9] ITU-T, *Vocabulary Of Terms For ISDNs*, I.112, 1998. Available: <http://www.itu.int/rec/T-REC-I.112-198811-S>
- [10] M.Rinne and O.Tirkkonen, "*LTE, the radio technology path towards 4G*", Computer Communications vol.33, no.16, pp. 1894–1906, 2010. Available: <http://www.sciencedirect.com/science/article/pii/S014036641000309>
- [11] H. Holma and A. Toskala (eds)., *WCDMA for UMTS, HSPA Evolution and LTE*, Fourth Edition, John Wiley & Sons, 2007.
- [12] A. Mishra, *Fundamentals of Cellular Network Planning and Optimization, 2G/2.5G/3G... Evolution of 4G*, John Wiley & Sons, 2004.
- [13] H. Holma and A. Toskala (eds)., *LTE for UMTS: Evolution to LTE-Advanced*, Second Edition, John Wiley & Sons, 2011.

- [14] Ericsson, *Heterogeneous networks –increasing cellular capacity*, White paper, 2011. Available: https://www.ericsson.com/res/thecompany/docs/publications/ericsson_review/2011/heterogeneous_networks.pdf
- [15] 3GPP, *Heterogeneous networks in LTE*, 2014. Available: <http://www.3gpp.org/technologies/keywords-acronyms/1576-hetnet>
- [16] A.Zakrzewska, D.López-Pérez, S.Kucera, and H.Claussen, "Dual connectivity in LTE HetNets with split control-and user-plane", 2013 IEEE Globecom Workshops (GC Wkshps), pp. 391–396, 2013. Available: <http://link.springer.com/article/10.1007/s11276-015-1037-6>
- [17] S.Jha, K.Sivanesan, R.Vannithamby, and A.Koc, "Dual connectivity in lte small cell networks", 2014 IEEE Globecom Workshops (GC Wkshps), vol.11, no.2, pp.1205–1210, 2014 . Available: <http://ieeexplore.ieee.org/stamp/stamp.jsp?arnumber=7063597>
- [18] Ericsson, *Heterogeneous networks- Increasing cellular capacity*, White paper, 2014. Available: https://www.ericsson.com/res/thecompany/docs/publications/ericsson_review/2011/heterogeneous_networks.pdf
- [19] 3GPP, *Study on Small Cell enhancements for E-UTRA and E-UTRAN*, TR 36.842, V12.0.0, 2014. Available: <http://www.3gpp.org/dynareport/36842.htm>
- [20] H.Wang, C.Rosa, and K.Pedersen "Dual Connectivity of LTE Advanced heterogeneous network", *Wireless Networks*, vol.22, no.4, pp. 1315–1328, 2016. Available: <http://link.springer.com/article/10.1007/s11276-015-1037-6>
- [21] Nokia, *3GPP R2-162499 Multi-connectivity considerations for New Radio 3GPP TSG-RAN WG2 Meeting #93bis*, 2016. Available: www.3gpp.org/-/ftp/tsg_ran/wg2_r12/TSGR2_76/Docs/
- [22] J.Puttonen, N.Kolehmainen, T.Henttonen, and J.Kaikkonen "On Idle Mode Mobility State Detection in Evolved UTRAN", *Information Technology: New Generations, ITNG'09. Sixth International Conference on*, pp.1195–1200, 2009. Available: <http://ieeexplore.ieee.org/stamp/stamp.jsp?arnumber=5070787>
- [23] Huawei, *3GPP R2 – 115919 Need of mobility state estimation enhancement in HetNet, 3GPP TSG RAN WG2 Meeting #76,,* 2011. Available: www.3gpp.org/-/ftp/tsg_ran/wg2_r12/TSGR2_76/Docs/
- [24] 3GPP, *Radio Resource Control*, TS 36.331, V12.7.0, 2015. Available: <http://www.3gpp.org/dynareport/36331.htm>
- [25] 3GPP, *User Equipment (UE) procedures in idle mode*, TS 36.304, V12.6.0, 2015. Available: <http://www.3gpp.org/dynareport/36304.htm>

- [26] NTT-DOCOMO and T-Mobile, *3GPP Speed dependent scaling of cell reselection parameters*, *3GPP TSG RAN WG2 #59*, 2007. Available: <http://www.3gpp.org/DynaReport/TDocExMtg--R2-59--26015.htm>
- [27] NGMN, *NGMN 5G White Paper*, tech. rep., 2015. Available: https://www.ngmn.org/uploads/media/NGMN_5G_White_Paper_V1_0.pdf
- [28] 3GPP, *Feasibility Study on New Services and Markets Technology*, TR 22.891, V1.3.2, 2016. Available: <http://www.3gpp.org/dynareport/22891.htm>
- [29] 5GPP METIS-II, *5G RAN Architecture and Functional Design*, tech. rep., 2016. Available: <https://metis-ii.5g-ppp.eu/wp-content/uploads/5G-PPP-METIS-II-5G-RAN-Architecture-White-Paper.pdf>
- [30] I.Da Silva, G.Mildh, M.Säily, and S.Hailu, "A novel state model for 5G radio access networks", 2016 IEEE International Conference on Communications Workshops (ICC), pp.632–637, 2016. Available: <http://ieeexplore.ieee.org/stamp/stamp.jsp?arnumber=7503858>
- [31] 3GPP, *Study on 3D channel model for LTE*, TR 36.873, V12.2.0, 2016. Available: <http://www.3gpp.org/dynareport/36873.htm>
- [32] Qualcomm, *3GPP 2-140089 Mobility Performance in Real Networks*, *3GPP TSG-RAN WG2 meeting #85*, 2014. Available: <http://www.3gpp.org/DynaReport/TDocExMtg--R2-85--30641.htm>
- [33] Qualcomm, *3GPP S3-160694-v1 reply LS on RRC Resume Clarifications* 2016. Available: http://www.3gpp.org/Liaisons/Outgoing_LSS/S3-meeting.htm
- [34] 3GPP, *3GPP 36331 CR 2231 (Rel-13)RP-161211 Introduction of NB-IoT*, 2016. Available: http://www.3gpp.org/ftp/meetings_3gpp_sync/ran/Inbox_history/2_Tuesday
- [35] ZTE, *3GPP R2 113794 Discussion on the mobility performance enhancement for co-channel HetNet deployment*, *3GPP TSG-RAN WG2 Meeting #75*, 2011. Available: <http://www.3gpp.org/DynaReport/TDocExMtg--R2-75--28498.htm>
- [36] 3GPP, *Feasibility study of new Radio*, TR 25.912, V13.3.0, 2015. Available: <http://www.3gpp.org/dynareport/25912.htm>
- [37] D.Forsberg, G.Horn, W.Moeller, and V.Niemi, *LTE Security*, Fourth Edition, John Wiley & Sons, 2010.
- [38] H. Holma, A. Toskala, and J. Reunanen (eds), *LTE Small Cell Optimization: 3GPP Evolution to Release 13*, John Wiley & Sons, 2016.
- [39] A.Prasad, P. Lunden, O.Tirkkonen, and C. Wijting "Energy-efficient flexible inter-frequency scanning mechanism for enhanced small cell discovery", Vehicular Technology Conference (VTC Spring), 2013 IEEE 77th. IEEE, 2013. Available: <http://ieeexplore.ieee.org/document/6692547/>

- [40] A.Prasad, P. Lunden, O.Tirkkonen, and C. Wijting "*Mobility state based flexible inter-frequency small cell discovery for heterogeneous networks*", PIMRC. 2013. Available: <http://ieeexplore.ieee.org/document/6666482/>

A Appendix

A.1 Mobility Parameters for RRC Connected States

n-CellChangeHigh: The number of cell changes to enter high mobility state. Corresponds to NCR_H in TS 36.304 [25].

n-CellChangeMedium: The number of cell changes to enter medium mobility state. Corresponds to NCR_M in TS 36.304 [25].

t-Evaluation: The duration for evaluating criteria to enter mobility states. Corresponds to TCRmax in TS 36.304 [25]. Value in seconds, s30 corresponds to 30 s and so on.

t-HystNormal: The additional duration for evaluating criteria to enter normal mobility state. Corresponds to TCRmaxHyst in TS 36.304 [25]. Value in seconds, s30 corresponds to 30 s and so on.

sf-High: The concerned mobility control related parameter is multiplied with this factor if the UE is in High Mobility state as defined in TS 36.304 [25]. Value Dot25 corresponds to 0.25, Dot5 corresponds to 0.5 , Dot75 corresponds to 0.75 and so on.

sf-Medium: The concerned mobility control related parameter is multiplied with this factor if the UE is in Medium Mobility state as defined in TS 36.304 [25]. Value oDot25 corresponds to 0.25, oDot5 corresponds to 0.5 , Dot75 corresponds to 0.75 and so on.

A.2 Speed Dependent reselection parameters in RRC_IDLE State

TCRmax: This specifies the duration for evaluating allowed amount of cell reselection(s).

NCR_M: This specifies the maximum number of cell reselections to enter Medium mobility state.

NCR_H: This specifies the maximum number of cell reselections to enter High mobility state.

TCRmaxHyst: This specifies the additional time period before the UE can enter Normal mobility state.

Speed dependent ScalingFactor for Qhyst: This specifies scaling factor for Qhyst in sf-High for High-mobility state and sf-Medium for Medium mobility state.

Speed dependent ScalingFactor for TreselectionEUTRA: This specifies scaling factor for TreselectionEUTRA in sf-High for High-mobility state and sf-Medium for Medium-mobility state.