

The Helsinki public library  
**“Re-thinking the public library”**

**Pablo Riquelme**  
**Master of Arts thesis**  
**Department of Design**

Aalto University  
School of Arts, Design  
and Architecture

Helsinki 2013



Oulunkylä library / Children area / Photography © Kuudes Kerros Ltd.

# Abstract

This paper describes the thinking behind the design concept for the new Helsinki Library, which was based on a recognition that the changing role of public libraries in the future needs to recognize the social context in which they operate. Service to the modern user means that a public library needs to accept a more social role. If libraries as institutions are to survive, they need to attract users and the design of the library must reflect this need.

“Libraries as such are dinosaurs, doomed to extinction, but build a really attractive building and call it a central library, a mall with natural light, interesting spaces, and a comic book shop, like the new library in Salt Lake City, and the punters will come, not for the books, but for the excitement and the human connections that only a great public space can generate. Libraries, in other words, can survive, but if they insist on their original mission, they will turn into enormous handsome ghost ships sailing along with all lights on and no passengers. On the other hand, if administrators decide that they can save libraries by sweeping all their dusty old-fashioned books into off-site storage and filling their cavernous loft like spaces with cafés and fast computers that might woo crowds back, these treasure houses would degenerate into bigger versions of Starbucks and Barnes and Noble, splendid public spaces which people frequent to use electronic sources, most of which they could find anywhere. Neither fate seems desirable and neither will restore the old function of the library as a training center for the crafts of scholarship.”

Anthony Grafton, *Codex in Crisis* (New York: The Crumpled Press, 2008)

# Table of contents

<b>ABSTRACT</b>	<b>3</b>
<b>1. INTRODUCTION</b>	<b>7</b>
1.1 Objective of this document	7
1.2 Background	7
1.3 Motivation	7
<b>2. HISTORY OF THE LIBRARY</b>	<b>8</b>
2.1 The traditional role of the library	9
2.2 The origin of the library in Europe	9
2.3 Development of the public library	10
2.4 The public library in Finland	10
2.5 Oulunkylä branch library	11
<b>3. USER EXPERIENCE DRIVEN IMPROVEMENT</b>	<b>13</b>
3.1 Design for change	14
3.2 The role of design in enhancing public services	14
3.3 Learning environment, the library as an eco-system	14
<b>4. DESIGN PROJECT, SELECTED FEATURES</b>	<b>19</b>
4.1 The role of service, the service desk and personal contact	20
4.2 Self service, the HelMet system	20
4.3 The storage of the collection, bookshelves and racks	20
4.4 The children's area, learn by playing	21
4.5 Space for new people, the youth areas	21
4.6 The failure of acoustics, a happy incident	22
4.7 Study booths, working or studying at the library	22
4.8 Lighting, the visual rules learned in retail	22
4.9 Hierarchy and functions: Books, web and coffee	23
<b>5. CONCLUSION</b>	<b>33</b>
<b>6. TECHNICAL DRAWINGS &amp; PHOTOGRAPHY SELECTION</b>	<b>36</b>
<b>7. BIBLIOGRAPHY</b>	<b>53</b>





Oulunkylä library / 2009

# 1. Introduction

## 1.1 Objective of this paper

The aim of this paper is to describe part of the design process that took place while developing a new interior architecture concept for the Helsinki City Library. The project was born as part of the implementation of a new service concept, which in turn led to a new concept of design. In this paper I describe the main features of the new concept of service and the elements that gave form to the new design.

The first library in Finland to benefit from this new concept was Oulunkylä branch library where the change was implemented three years ago. The experience gained from this first prototype has been valuable in implementing change in other locations. The design, however, is still developing and of course some of the features that were considered important at the start are now, since we started this research, perceived as out of context.

Despite those changing perceptions the main questions behind the new interior architecture design remain:

**What is the role of the public library in the future?**

**And how can the library survive the challenges that time will bring?**

From my point of view as a designer, I believe the answers are to be found in observation and concrete co-operation between the community and professionals in order to develop, preserve and enhance this public institution, which has such a big place in the hearts of so many people.

## 1.2 Background

My relationship with the Helsinki City Library started as a consultant designer during my years of study. The first task given was the assignment of a project

during the year 2000 when the city of Helsinki was celebrated as European culture capital city.

I was asked by the Library to develop an itinerant exhibition system to display an international exhibition of artwork done by children from around Europe.

Later, during my involvement as founder of the brand and design agency Kuudes Kerros, I continued my link with the Library with more ambitious projections for development assignments.

During the year 2007 we started conversations again and we were asked to develop a project around a question set by the library... "What should be the role of the new library...?"

We arranged a team and agenda committed to give an answer to this challenge.

The process was divided and developed in two parts:

- a) The development of a new service concept;
- b) The proposal for a new interior architecture concept.

Personally I was involved in both parts of the process, but with special emphasis on the development of the design proposal for the Oulunkylä library (Neighbourhood of Helsinki), as this was chosen as the first location to be developed.

The entire project was carried out through teamwork and a great deal of recognition belongs to the creative team of Kuudes Kerros agency.

## 1.3 Motivation

From the start of my studies in the field of design, I was motivated by curiosity and the desire to make myself useful and serve society. In many senses this youthful and perhaps naïve motivation develops an even stronger character while working for

public organizations, such as the public libraries.

However, this original desire to make myself useful and serve society may to some people appear to have lost its incentive when viewed from the perspective of the present, considering the many years I have spent working for and with commercial entities that in many ways have shaped my own professional profile.

Working for and with commercial entities, however, provides a designer with excellent skills to carry into his work for public organizations. I have to say that the best learning experiences of the relationship between space, content, people and social aspects I got from my years working for advertising and retail.

Beyond the obvious drivers used in these areas, the methodology used and the knowledge gathered by these kinds of organization is simply amazing.

In order to fulfil commercial expectations within very short timeframes, any effort for any project must be focused and executed as meticulously as possible. So the profiles, manners and behaviour of the users have to be identified before any design exercise can take place. Defining the social context and considering the needs of users is absolutely vital to the success of any commercial design project.

From my years working with commercial entities I realised that much of the methodology used to achieve commercial goals can successfully be applied in order to enhance the design of public services such as libraries and health facilities, etc.

In many ways the opportunity to work with the Library of Helsinki and especially on such a large scale project has been a dream case: the design process has included an extraordinarily wide range of different disciplines, all related to the paramount consideration of the social implications of the Library's use and future.

# 2. HISTORY OF THE LIBRARY

## 2. History of the library

I am not a historian, but in working on the new interior architecture for the Helsinki Library as it moved into the needs of its role in the future, it was necessary to have some understanding of the role of the library in general in the past and of how that role may have changed over the centuries. This understanding is not central to this paper, but a brief look at excerpts from the writings of those who are historians of libraries, gives an overview of what has been understood in the past by the term 'library' and may throw some light on how public libraries, that is, libraries used, not by scholars or monks or academic specialists, but by the general public, need to develop for the future.

### 2.1 The traditional role of the library

"Libraries are collections of books, manuscripts, journals, and other sources of recorded information. They commonly include reference works, such as encyclopaedias that provide factual information and indexes that help users find information in other sources; creative works, including poetry, novels, short stories, music scores, and photographs; nonfiction, such as biographies, histories, and other factual reports; and periodical publications, including magazines, scholarly journals, and books published as part of a series. As home use of records, CD-ROMs, and audiotapes and videotapes has increased, library collections have begun to include these and other forms of media, too."

(Leigh S. Estabrook, Encyclopædia Britannica)

"In earliest times there was no distinction between a record room (or archive) and a library, and in this sense libraries can be said to have existed for almost as long as records have been kept. A temple in the Babylonian town of Nippur, dating from the first half of the 3rd millennium bc, was found to have a number of rooms filled with clay tablets, suggesting a well-stocked archive or library. Similar collections of Assyrian clay tablets of the 2nd millennium bc were found at Tell el-Amarna in Egypt. Ashurbanipal (reigned 668-c. 627 bc), the last of the great kings of Assyria, maintained an archive of some 25,000 tablets, comprising transcripts and texts systematically collected from temples throughout his kingdom." (Encyclopædia Britannica)

"The Library of Alexandria, in Egypt, was the largest and most significant great library of the ancient world. It flourished under the patronage of the Ptolemaic dynasty and functioned as a major center of scholarship from its construction in the 3rd century BC until the Roman conquest of Egypt in 30 BC. The library was conceived and opened either during the reign of Ptolemy I Soter (323-283 BC) or during the reign of his son Ptolemy II (283-246

BC). An early organization system was in effect at Alexandria." (Information drawn from Wikipedia)

### 2.2 Origin of the library in Europe

"The celebrated book collectors of Hellenistic Antiquity were listed in the late 2nd century in Deipnosophistae. All these libraries were Greek; the cultivated Hellenized diners in Deipnosophistae pass over the libraries of Rome in silence. By the time of Augustus there were public libraries near the forums of Rome: there were libraries in the Porticus Octaviae near the Theatre of Marcellus, in the temple of Apollo Palatinus, and in the Bibliotheca Ulpiana in the Forum of Trajan. The state archives were kept in a structure on the slope between the Roman Forum and the Capitoline Hill.

In the 6th century, at the very close of the Classical period, the great libraries of the Mediterranean world remained those of Constantinople and Alexandria.

By the 8th century first Iranians and then Arabs had imported the craft of papermaking from China, with a paper mill already at work in Baghdad in 794. By the 9th century public libraries started to appear in many Islamic cities.

The contents of these Islamic libraries were copied by Christian monks in Muslim/Christian border areas, particularly Spain and Sicily. From there they eventually made their way into other parts of Christian Europe. These copies joined works that had been preserved directly by Christian monks from Greek and Roman originals, as well as copies Western Christian monks made of Byzantine works. The resulting conglomerate libraries are the basis of every modern library today.

Also, in Eastern Christianity monastery libraries kept important manuscripts. The most important of them were the ones in the monasteries of Mount Athos for Orthodox Christians, and the library of the Saint Catherine's Monastery, Mount Sinai for the Coptic Church.



The 17th and 18th centuries include what is known as a golden age of libraries; during this some of the more important libraries were founded in Europe, such as the Bodleian Library at Oxford, the British Museum Library in London, the Mazarine Library and the Bibliothèque Sainte-Geneviève in Paris, the Austrian National Library in Vienna, the National Central Library in Florence, the Prussian State Library in Berlin, the Załuski Library in Warsaw and the M.E. Saltykov-Shchedrin State Public Library of St Petersburg.” (Information drawn from Wikipedia)

### 2.3 Development of the public library

Most of the libraries described above, however, were not open for free use by the general public. The first truly public libraries began to appear, for the most part during the 18<sup>th</sup> and 19<sup>th</sup> centuries, and initially mainly in the English-speaking world. Their development varies from one country to another, but they were all driven by the increase in literacy. The following are a few examples of the development in different countries.

#### The United Kingdom of Great Britain

By the 18<sup>th</sup> century many middle class people in the United Kingdom belonged to a subscription library, where they could borrow books, generally novels, for a fee. The establishment of a system of public libraries throughout the country, funded from public money, was not legislated for before the middle of the 19<sup>th</sup> century when the United Kingdom passed the Public Libraries Act in 1850. Following this act public libraries with free lending rights were opened in most urban areas. (Information drawn from Wikipedia)

#### The United States of America

“As the US developed from the 18<sup>th</sup> century to today, growing more populous and wealthier, factors such as a push for education and desire to share knowledge led to broad public support for free libraries. In addition, money donations by private philanthropists provided the seed capital to get many libraries started. In some instances, collectors donated vast book collections.

There are disputes about which was the first public library in the nation. Early American cities such as Boston and Philadelphia and New York had the first organized collections of books, but which library was truly “public” is subject to dispute. The official Boston Public Library was organized in 1852.” (Information drawn from Wikipedia)

#### Canada

“In Saint John, New Brunswick in 1883, the first free, tax-supported public library was established. Guelp, Ontario and Toronto opened public libraries that same year as well.” (Information drawn from Wikipedia)

### 2.4 The public library in Finland

As with other countries, it is difficult to determine the exact process of the establishment of public libraries in Finland. However, we can point to a few historical happenings that have straight implications for the foundation:

- **The Helsinki University Library, commissioned by the Emperor Nicholas I and completed in 1840, was the first purpose built public library in Finland**

- **The formation in Europe and America of reading societies and subscription libraries in the second half of the 18<sup>th</sup> century,**

**motivated by international developments such as the enlightenment movement increased interest in reading also in Finland. The basis of the public library may be found in the number of reading societies that flourished during that period of time, e.g. the reading cabinet established in Turku 1798 and the foundation of the reading society’s “reading library” of the City of Vaasa in 1794.**

In addition to these events, there is also evidence from the early 1700s of the book lending services which the church provided to communities. Of course, most of the material offered by the church was related to religious matters; nevertheless, the lending services can be seen as an early precedent for contemporary public libraries.

From the late 19<sup>th</sup> century onwards, following the foundation of the Society for Popular Education, its ideology, which was aimed at introducing popular education to all segments of the population, spread across the country. This endorsement triggered the relatively fast implementation of public libraries in rural areas, aiming to narrow the gap between common people and the intellectual elites.

These efforts increased from the 1860s till the beginning of the 20<sup>th</sup> century by which time the libraries destined to serve common people were established in 2000 locations, a considerable accomplishment.

Much later, by the beginning in the 1960s we can identify the start of the golden age for the public libraries in Finland. Endorsed by the political efforts on restructuring the society into a welfare state, the improvement of the library services became part of a priority agenda, which meant more resources for the library.

Finally, after the reconstruction years following the Second World War, Finland was

ready to invest in culture as part of a modernization strategy and determination to prepare its people for the future to come, acquiring the needed competitiveness and knowledge demanded, to enter on a very visionary task that had the public library as one of its main pillars.

As a consequence of the positive economical changes of this period we had a growing middle class, with access to more services and opportunities, having the public library as one of its preferred institutions.

Following the changes still being implemented in the 1970s, later in the 1980s the library did suffer some kind of stagnation, probably produced by the economic boom which benefited the population and caused changes in their social behaviour, allowing them the economic means to spend free time in a variety of ways. This period was also the starting point for the automation of the library systems.

The 1990s started with a critical break down of the national economy. This situation brought cuts to the resources assigned to the public libraries, changes that are believed to persist till this day.

Nevertheless at the same time the library achieved historical lending statistics, probably also caused by the increasing number of unemployed people that found refuge at the library. The 90s was also the time when technological integration took part and the library system was added to the Internet environment.

The role of the public library within the digital environment may be something still to be found; this can include more than processing data or connecting library networks with users, it may also mean to create the channels and opportunities to produce and deliver content. This scenario together with the declining role of printed knowledge sources may provide sugges-

tions for the future of the library. (Suomen yleisten kirjastojen historia, Ilkka Mäkinen 2009 ) (Finnish public libraries in the 20<sup>th</sup> century, Ilkka Mäkinen 2001) (The Finnish Library, Hanna Aaltonen 2012)

### 2.5 Oulunkylä branch library

The Oulunkylän Finnish Cultural Society had already delivered library services to the community in 1919, and by the early 1920s, the library was regularly open a couple of times a week. The local schools also provided a number of smaller libraries.

In spite of these beginnings, Oulunkylä did not have a public library until a canton annexation took place and the City of Helsinki founded the Juhannusmäkeen branch library in Oulunkylä in the year 1950. By the year 1954 the Oulunkylä branch library had a collection consisting of 5,612 volumes, and a subscription to 23 magazines. Book loans in the same year were 19,760, 80 per cent of which were Finnish-language material.

The library’s worst daily loan figure of the day was during the 1952 Olympics on the Wednesday of the mountain bike competition. The library was almost inaccessible and then loaned just two books during the whole day.

The first branch chief librarian was Sven Hirn, who was later elected Helsinki Library Director in 1963. Among his successors in Oulunkylä we can count, for example, the prominent writer and Baron Bo Carpelan. The longest serving chief librarian was Gun Forslund-Anttila, was appointed just before the library was moved to a different location in 1959 and who continued the mission until 1994.

In 1959 the library received adequate facilities at the Oulunkylä Elementary School in Norrtälje Street. Already by the 1970s these facilities had become too crowded

and discussions began on the need for a new neighbourhood library.

The current library was built in a new shopping centre courtyard in 1987 by the architect bureau Simo Järvinen & Co. with a built surface of 819 m<sup>2</sup>.

The library’s appearance was renewed in 2010 through an extensive renovation, which was piloted by the Helsinki Public Library; the Fennia Prize was awarded for the new design concept in 2012. (Concept which is subject of this paper)

Oulunkylän library aims to be an active living room for the residents of Oulunkylä. Its collection includes more than 50,000 titles, books, magazines, DVD movies and CDs. Loans each year amount to nearly 400 000. The closed Oulunkylä collection, which is available for consultation but not for loan, includes a wide range of material about the history of Oulunkylän and its present descriptive works, some of which are not available anywhere else.

The Helsinki City Art Museum has provided the Oulunkylän library with artwork from Erkki Kannosto: “Aitiopaikka” bronze sculpture dates back to 1975 and Teemu Luodon ceramic sculpture “The Lion” from 1976.

In addition the library has received donations from the artist Onni Mansnerus “Pukinmäen bohemian”, and the neighbouring Professor Erkki Koponen’s paint work “metamorphosis”, Also Erkki Kannosto has brought to the library a bronze sculpture “Pilot” from his private collection.

During August of 2012, the Finnish Artists Circle organized an exhibition based on the work of 18 studio houses in Oulunkylä which became a great success. [http://www.kaupunginosat.net/oulunkyla/kaupunkipolku/makitorppa/slides/m25\\_kirjasto.htm](http://www.kaupunginosat.net/oulunkyla/kaupunkipolku/makitorppa/slides/m25_kirjasto.htm)

3.

USER

EXPERIENCE

DRIVEN

IMPROVEMENT

# 3. User experience driven improvement

## 3.1 Design for change

"Do we need a new product every three minutes? I don't think so. On the contrary: the survey evidence is overwhelming that citizens despair at this flood of often pointless trash they are told will make them happy.

At the same time, state spending on public services in many countries is likely to shrink by a staggering 20-40 percent in the coming years as the bill for the financial bailout comes due. In the coming social economy, the role of governments in countries will unavoidably change, and radically, away from the point-to-mass delivery of centrally-produced and paid-for services. (John Tackara, [www.doorsofperception.com](http://www.doorsofperception.com))

"Recent evidence shows that design methodologies can drive innovation in public services. (UK design council, [www.designcouncil.org.uk/our-work/insight/research/research-briefings/the-role-of-design-in-public-services](http://www.designcouncil.org.uk/our-work/insight/research/research-briefings/the-role-of-design-in-public-services))

With "innovation" being the trend word of the moment, we frequently associate this term with technology and heavy investment.

When it comes to the field of public services I believe the solutions are often more related to enhancing the experience of the users when they are taking part in the service process. This does not necessarily happen through bringing the latest gadgets and technology. Improvement in service starts by observing and asking for the needs and expectations of the people involved in the service.

In the case of the library through the observations done during the pre-design period, we understood the importance of a number of details more related to personal perception than the lack of infrastructure or content; things like signage, clear information about the existing

services, well defined activity areas and personal engagement of the staff, were the most recurrent concerns.

Clearly in this case the simple application of design as an aesthetic or complementary factor would not have brought a sustainable solution. As an alternative, we developed an environment based on the experiences gathered with the users and staff, using different research tools centered significantly in the concept of user experience.

This approach gives the potential for social innovation products of co-design, working together with citizens and communities. By succeeding in the implementation of this methodology, the same process can be adapted to design in areas with different social issues.

## 3.2 The role of design in enhancing public services

"Investment in public services has increased dramatically over the last decade, but today's services must respond to new challenges including a low carbon economy, an ageing population and the rising demands of service users. These pressures make innovation essential – public services must be designed to meet the complex needs of users while delivering cost efficiencies." (Design Council, UK)

Recent evidence shows that design methodologies can drive innovation in public services. Rapid prototyping creates efficiencies by designing out problems early, and the collaborative nature of many design projects can engage public sector workers, frontline staff and users in the development and delivery of new services.

However, research also shows that many public service providers lack the knowledge and skills to use design as a strategic approach to innovation. Developing this capacity would help public sector organi-

zations manage their creative processes and find innovative solutions for service delivery.

## 3.3 Learning environment, the library as an eco-system

During recent years researches from different areas and from different countries have concentrated studies on the implications of creative learning and the important role of the environment while developing different productive activities. Following these trends and the conclusions from the libraries' new service concept, I considered the need to create dynamic and specific areas within the new space as one of the corner stones of the design.

If tradition says that the main mission of the library is to collect, maintain and distribute knowledge, I argue that the library should also become a generator of knowledge rather than simply remaining a passive accumulator.

Contemporary studies suggest that the environment directly affects our capacity to learn and share information; beside cognitive elements we recognise also social factors that enable people to exchange knowledge, thinking and ideas. There is a popular belief that "by doing we learn". I wanted to stick with this thought and to help to create an ecosystem of different environments within the frame of the library, spaces far from the traditional silent and bureaucratic library atmosphere, environments supporting social interaction.

Especially important I considered the children and young people's spaces. In fact these specific groups will in the longer term define the future of the library. Without good experiences to remember it is not possible to build a strong attachment; without enabling playing and interaction, the library becomes just a monument with half of its mission unaccomplished.

## New

- graphic signage- colour codes
- seasonal campaign
- atmosphere
- amount and way to display the books
- fragmentation of spaces/functions, creating different "worlds"
- flexible areas (living room...)

## To delete

- permanent fixed areas
- strict bureaucratic atmosphere
- unclear and small signs
- long waiting before getting advice

## To emphasize

- variety/diversity
- social network
- easy and interesting atmosphere
- communal activities
- fresh knowledge
- self service
- "my library" feeling

## To keep

- the library collection
- personal service
- open doors for all people
- quiet spaces
- the books...





Functions / Mood board

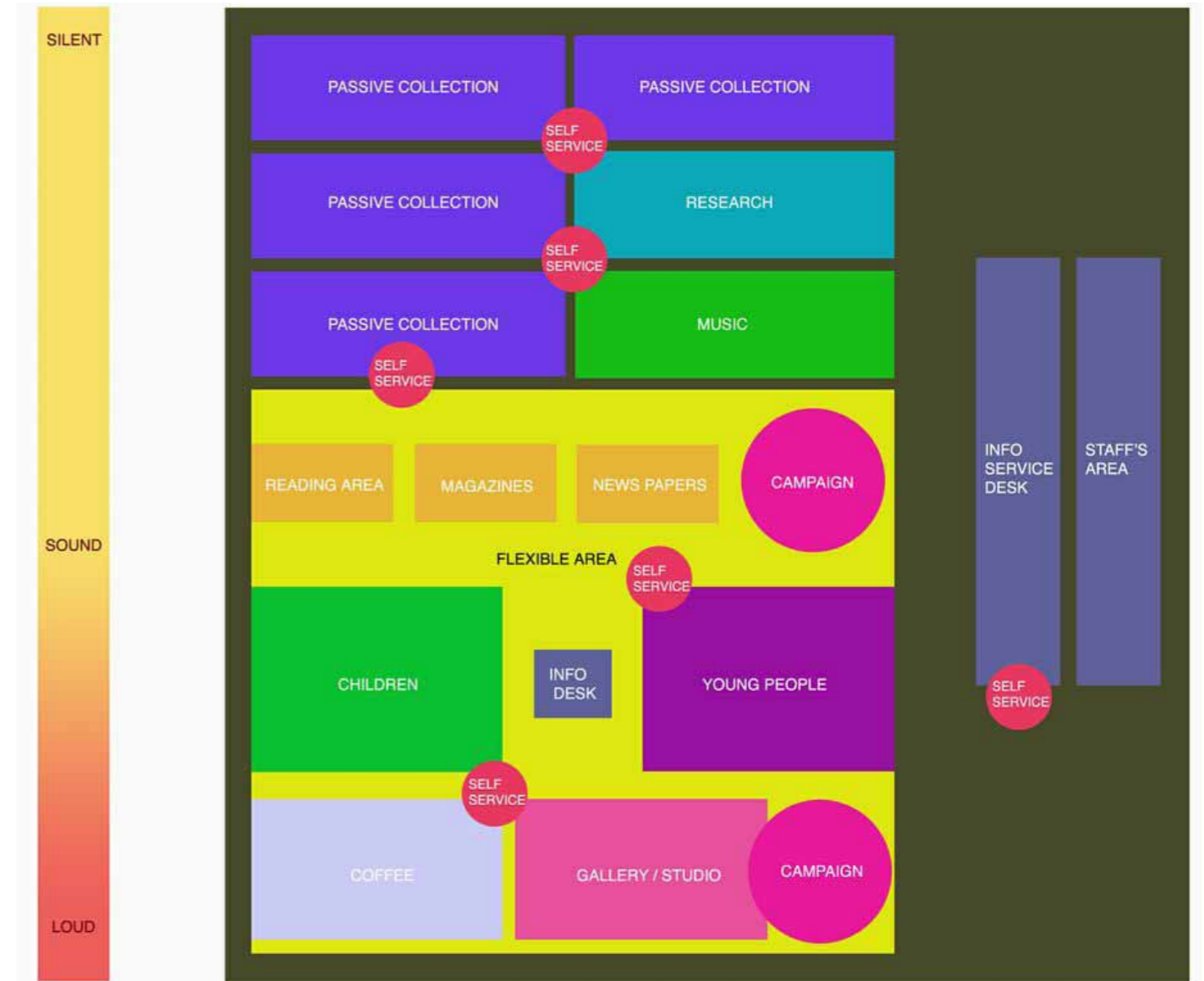

New library / Space program diagram



# 4. DESIGN PROJECT, SELECTED FEATURES

# 4. Design project, selected features

“Well-designed social spaces are likely to increase students’ motivation and may even have an impact on their ability to learn. High-quality space for informal learning will also enhance the profile of the institution with its target groups. For these reasons, social spaces are given a high priority in new designs, but this cannot happen at the expense of increasing the overall dimensions of the building. Large, underutilized spaces already exist in most colleges and universities. If catering facilities, common rooms, even corridor space, are reconsidered as social meeting and group learning environments, institutions could both save on large-space provision and make a statement about their vision for learning as a pervasive and inclusive activity based on social interaction.” (Designing Spaces for Effective Learning, www.jisc.ac.uk)

## 4.1 The role of service, the service desk and personal contact

An important part of the service enhancement process was the analysis of the service desk; apart from Oulunkylä in many libraries the function of the desk as a service surface becomes a barrier between the user and the librarian.

The new proposal consisted of the introduction of personal desks on a smaller scale as service desks, replacing the large one body construction.

The idea was to create a more approachable service atmosphere; also motivating the library staff to move more around the library space and to give more attention to the users near to the places where they spend time.

In addition to the main service desk area, we introduced a smaller service point in the middle of the space. The introduction of self-service points (HelMet) also increased the info spots within the library.

A small but meaningful detail concerning the main service desk area was the inscription fixed on the surface above the service area saying, “Welcome”

## 4.2 Self service, the HelMet system

HelMet-kirjasto (Helsinki Metropolitan Area Libraries) is the Helsinki, Espoo, Vantaa and Kaunianen city public libraries network.

Helmet is a joint loan system which allows use of all the libraries joined in the system. With a single user identification card, users can borrow, order or make reservations from any of the main or branch libraries on the system. They can also return items to any service point in any library on the system.

HelMet has been a most successful and user-friendly system, but we believed that it was necessary to make the system more visible and somehow to bring to users’ attention both the virtual and physical

benefits of the service: connectivity and self-service. The library already had a PC terminal for the exclusive use of HelMet, but without any specific signage or element that could help the users to identify immediately the PC’s location or purpose.

We introduced a tall but narrow element to hold the necessary IT hardware, equipped with a screen, keyboard and mouse. A number of these elements, clearly visible, were distributed around the library space in order to underline the feeling of the new concept – “service always near”.

## 4.3 The storage of the collection, bookshelves and racks

“In a good bookroom you feel in some mysterious way that you are absorbing the wisdom contained in all the books through your skin, without even opening them.” (Mark Twain)

For most people when we talk about libraries, the image of endless corridors, high bookshelves and the distinguished fragrance of old paper automatically comes to mind. That is the library in many users’ imagination.

During the process of designing a new interior architecture to back up the new service concept, we many times crashed with this romantic idea of a library. We wanted less printed material, more happenings, more openness, but these changes could not happen without us playing the “evil role” and proposing to reduce the amount of book storage in the user areas and add more air above the shelves; the most (for many) shocking proposal was to change the gentle oak surfaces of the shelves to deep black wooden veneered surfaces.

### The most important reasons for these changes were as follows:

- The library is not a warehouse of printed material.
- We need a open and clear vision of the space.

- The printed material to be kept must play a stronger visual role in the library, in the hope that the users can at least find literature through the exposed art work of the books.

I must say that the changes proposed are considered by many people till this day too radical, based mostly on very personal appreciations and opinions.

As a designer I found that this simple colour and light exercise did produce major changes within the atmosphere of the library.

## 4.4 The children’s area, learn by playing

Keeping the attention of the young users of the library is a challenge, and to keep a relationship with future customers will require a major effort on behalf of the library in order to create interesting services and programmes for children and to gain the commitment and motivation of their parents to help them to discover the opportunities and fun the library can provide.

Regarding most of the children’s library areas that I have studied, in most of the cases the change of scale in the furniture is the only visible change previous planners have achieved, the only concession made to the needs and wishes of very young users.

I believe that children experience an environment from a totally different perspective than that of adults. This goes beyond scale appreciation; the whole atmosphere can attract or repulse a young child. I am talking about textures, colours, shapes, differentiation of height and light values, and besides, all the messages the space communicates.

I chose to create a fairytale around the children’s area, a exclusive space with special character, a reading and playing space by the foot of a tree, under branches like elements, with a soft upholstered

corner to have reading sessions, colourful furniture in a appropriated scale and a more relaxed layout.

The goal is to embed the children with positive, beautiful experiences in order to create a link that can bring them back when they become able to decide where to spend their time.

Because of course small children arrive with their parents or teachers, we also provided open flexible areas next to the children’s corner. This space is equipped with low chair and low tables allowing the users to have a minute of relaxing free time while guarding the kids.

## 4.5 Space for new people, the youth areas

In commercial projects while proposing any kind of service, there is a need for research in order to spot the competition around the solution you are about to create. This thought may feel remote from the context of the library, considering the status and history of the organization, but I insisted that whatever we proposed had to be filtered within the framework of “time spending”. In the case of the library it competes with any and every other entity that offers time-consuming activities to people.

In the situation of Oulunkylä library in the segment designed for young users, we had the special goal of attracting youngsters and of introducing them to the new services in a “less scholastic” way, if I may say so.

Next to the library location, there is a local shopping mall, so now the exercise was to take these groups of youths away from hanging around the mall and to provoke them to rediscover the library.

We proposed a specific and very flexible area with storage shelves that can be moved around, low upholstered benches, a wall covered with graphic wallpaper holding bookshelves, a low surface with a large



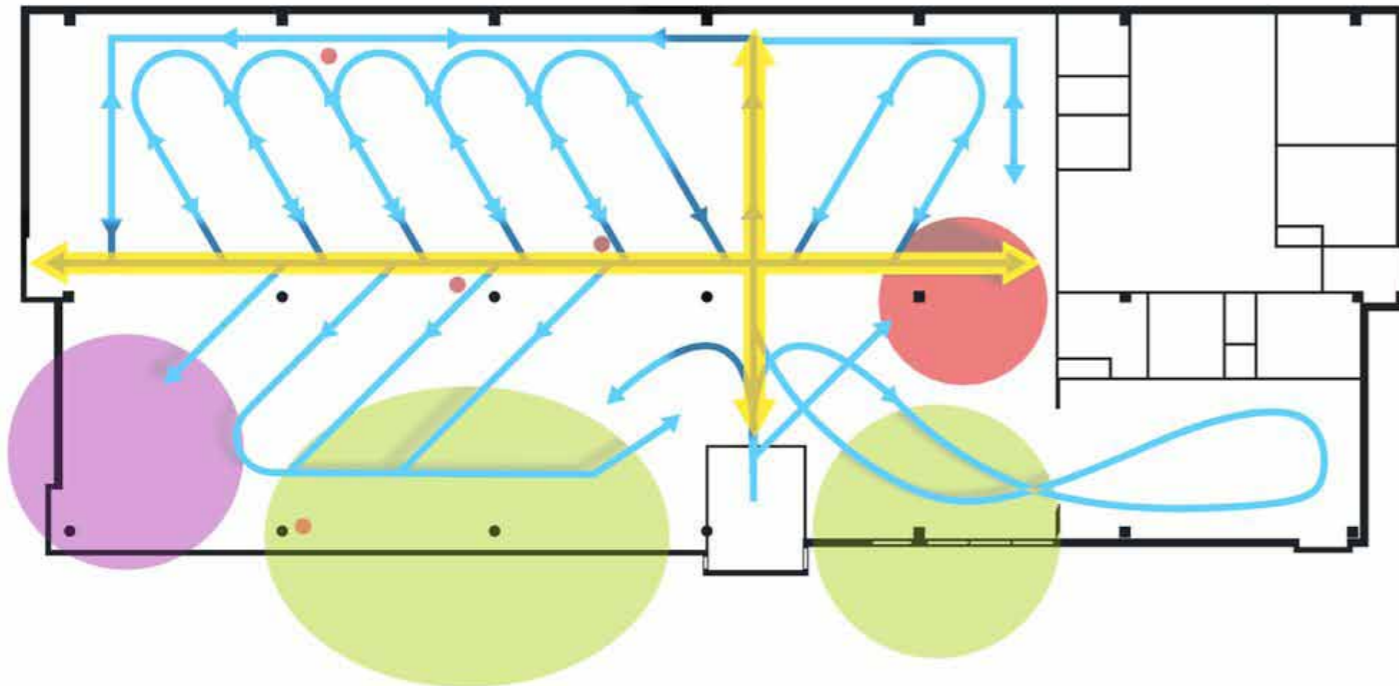

Oulunkylä library / Customer flow / Sketch

flat screen and video game device – in all of this I wanted to create a more personal atmosphere, something more dedicated to teenagers and to create a feeling of ownership dedicated to them.

I believe that with really simple features we created a special place for this user group; now it is up to the library staff to create a bond with them and generate trust and cooperation.

#### 4.6 The failure of acoustics, a happy incident

Shortly after the opening of the new premises of the library I was contacted by the library staff to re-check the acoustics of the place. During the design of the restructuring of the interior construction of the library, we had approached the acoustic issue by changing surface materials and adding special panels to the recessed ceiling. Now after few weeks operating the library seemed to have big troubles with noise levels.

After organizing a debriefing meeting I was totally surprised and happy to hear that the biggest problem was the noise coming from the open areas designed for the youngsters!

What we had here was more than a technical challenge; it was the achievement of one of our principal goals, to attract new users with a special emphasis on children and young people.

After this happy incident a few elements were added to improve the overall acoustics of the space, but one of the most singular details that may be subject for further studies was the “common agreement” the library had to make in order to educate young people about the proper use of the library and to promote to other user groups the tolerance and understanding to accept a new kind of culture moving into the library; This phenomena displays again the great future role of the library as a social blender and a cultural change enabler.

#### 4.7 Study booths, Working or studying at the library

In the original library there was a small room reserved for people who wanted isolation or the need to work with a personal computer for a period of time. The challenge was to create more than one space with the mentioned characteristics but also a place that would avoid the inap-

propriate use of an enclosed space or a loaned PC.

We proposed a number of “Study booths” with acoustic qualities, own lighting and enough visibility to permit the library staff to control the correct use of them.

In a reduced space such as Oulunkylä this was the best solution and the colourfulness and originality of the elements was very welcomed by the staff and users.

#### 4.8 Lighting, the visual rules learned in retail

There is almost no exception to the rule that correct lighting is almost the most important element of design. The role of illumination is vital when applied to any sort of space that is meant to gather people around products or services. The disappointing fact is how very common it is to find warehouse lighting in most of the environments destined for public services I have to emphasize that, “Is not about the amount of light in the space but all about the atmosphere we want to create”.

In the case of the Oulunkylä library proposal we handed the lighting to professional suppliers. We wanted to create a differentiation of values through the

amount of light used; we have spot lighting between shelves, decorative light elements placed in different areas, other elements creating a different effect in different areas (children, reading areas, etc.)

The positive outcomes of using the correct lighting can also affect the span of time and number of visits a user gives to a place.

#### 4.9 Hierarchy and functions: Books, web and coffee

As I described in the previous sections, the library is an assembly of different spaces destined for different functions. If we compare the initial situation of the Oulunkylä branch library, the original layout was very conservative and the interior elements followed a horizontal-vertical pattern in accordance with the geometry of the building; by simply looking around you could not understand the different functions of the space without reading the written signs and stickers placed in different formats and sizes.

Through the changes proposed, the functions and possibilities of the space become evident as soon as the user steps inside the library:

- Service
- Self service
- Collection
- Specific functional areas
- HelMet (Web based self service system)

Besides the distinctive character of each area or element, the concept included a new signage system, which intended to make the use of the services easier. This new element was supported by clear typography and colour-coding, which was

developed by Kuudes Kerros creatives.

Each one of the elements included in the new library was designed to promote its use without underestimating the opinions of the devoted users the library already had and the traditions the organization somehow had to communicate.

One of the most popular services the library provides is the magazine and newspaper reading area. Previously this area was organized with low arm chairs and low tables for individual reading. We changed this layout by introducing a long “kitchen-like” or “refectory” table surround by chairs and lit by hanging lamps above the table. A huge change was the introduction of an automatic coffee machine installed in the area, so now you have all the elements needed to enjoy reading the paper with your cup of coffee beside you, and possibly, some gentle interacting and quiet talk with other fellows.

Because the awareness of new technology and media has to be present in the library space, we integrated a number of computer devices, mostly concentrated in one specific area. Electric sockets were also displayed to provide power and the chance to work with the user’s own laptop or with the ones the library lends. A large working table was installed between the shelves of the collection area, in order to facilitate a silent but dynamic working space.

In order to communicate the variety of services the library offers, it is necessary to open them up to the users through content but also through visual elements. To avoid a flat environment we created a hierarchy of spaces, messages and functions. This way we aim to create a positive and exciting experience while using the library.



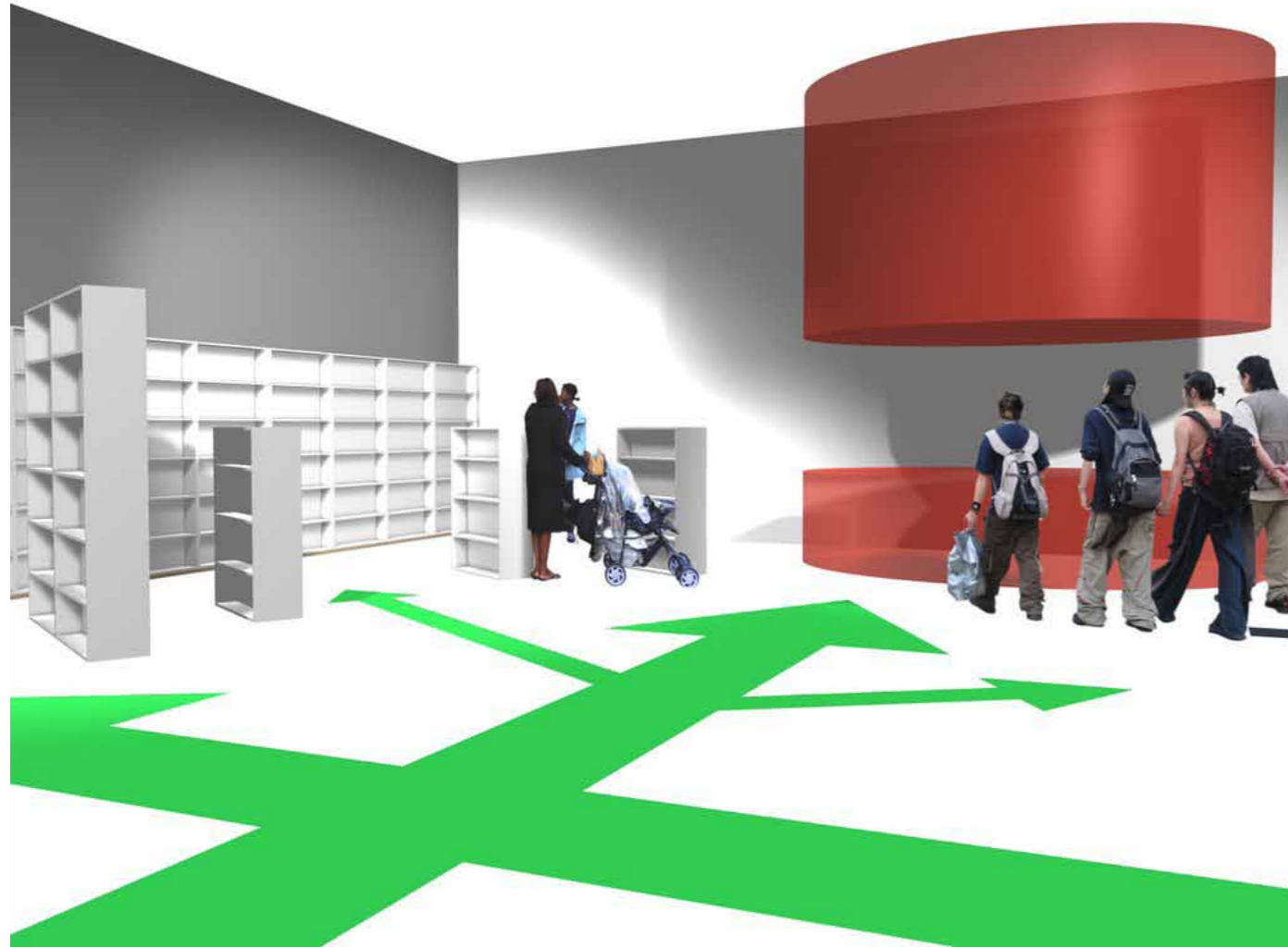

Oulunkylä library / Customer flow study



Oulunkylä library / Customer flow study



Oulunkylä library / Sun light study  
 Oulunkylä library / Noice study



Oulunkylä library / Info sign / Sketch  
 Oulunkylä library / Children area element / Sketch



Oulunkylä library / Study booth sketch



Oulunkylä library / Self service device sketch



Oulunkylä library / Lower book shelf sketch



Oulunkylä library / HelMet service sketch





Oulunkylä library / Outdoors sign sketch  
Oulunkylä library / Service desk sketch



Oulunkylä library / Perspective sketch



5.

# CONCLUSION

## 5. Conclusion

### "A library implies an act of faith".

(Victor Hugo)

Since the creation of public libraries around the world and also in Finland, these organizations had the vital mission of educate and introduce people to the various paths of knowledge and enlightenment.

In Finland the library had a substantial role on building a democratic, equalitarian and modern society, the achievements of a not small group of people wouldn't be possible without the existence of the library. The question now is: "Do we still need the library?"

We have witness the transition of a world based on printed knowledge to a society based on free access to digital content of every kind and quality, if only few years ago the task of founding information, getting traces of history or having a visual research of different subject would not be possible without visiting a library, spending time between shelves, searching and hand writing documents and having to reserve a appointment with the local librarian.

Now most of us are carrying the biggest sources of information the world ever had seen even in our own pockets, for example in a super compressed format like in a cell-phone, always open, always there, always accessible.

As technology has revolutionized every aspect of our lives it has also change probably forever the way we learn, interact and discover our world. Google, Wikipedia, YouTube, etc. May have replaced the wise image of the librarian in a precious milieu of a library corridor, but we have to keep on mind that the exchange of knowledge as it best happens through the interaction of two individuals or more.

**"A lot of basic assumptions about what a library is and should be are on the table in a way that they haven't been since the industrialization of printing," says Jeffrey T. Schnapp, faculty director of metaLAB at Harvard and a professor of romance languages at the university's Graduate School of Design. "There's a shift of their core identity, away from places where documents are housed, to physical structures that can serve as nodes that add value to the act of consultation."**

And on the original function of lending books:

**"Increasingly, people can use that material anywhere that they want to, which means they come to the library for other needs," says Jim Neal, the vice president for information services and university librarian at Columbia University. "They come to study. They come to work together. They come to use technology they can't carry around. They come here to consult with experts, with librarians."**

(Metropolismag.com, Mark Lamster 20.07.2012)

We need to reformulate the relationship between users and the library, and let this last to flourish into new directions, to keep on enriching peoples life and keep on been a support of culture.

I believe the new role of the library is not going to be found within the traditional function of guarding printed or physical pieces of knowledge, I believe the value of the new library should be found on its capacity of gathering residents together, on the capacity of creating and facilitating bridges of collaboration and understanding.

Perhaps opening new possibilities for older people to share their life experiences or to familiarize children a youngster with other social groups their behaviors and social codes or even to become to be the first contact surface for immigrants from inside and outside the country.

I believe we have to look above the bookshelves and see the real value and lessons the library has teach us: equality, overcoming and respect; This are the concepts that have taken successful societies to healthy development, we can not forget that the preservation of our cultures and their symbols such as the public library is not only the job of few but of us all.

If in the past the library was a open window to a better future and faraway landscapes, in future scenarios the library could become a window to our inner richness as culture as a human group engaged to create a better society and a more humanized future.

I envision the library of the future as an "urban living room" an arena for social and cultural debate, a market of ideas and skills, a blender of cultures.

**"NYPL was my first best friend  
when I moved to New York City."**   
B.H., patron

# 6. TECHNICAL DRAWINGS & PHOTOGRAPHY SELECTION



/ Image © Kuudes Kerros Ltd.

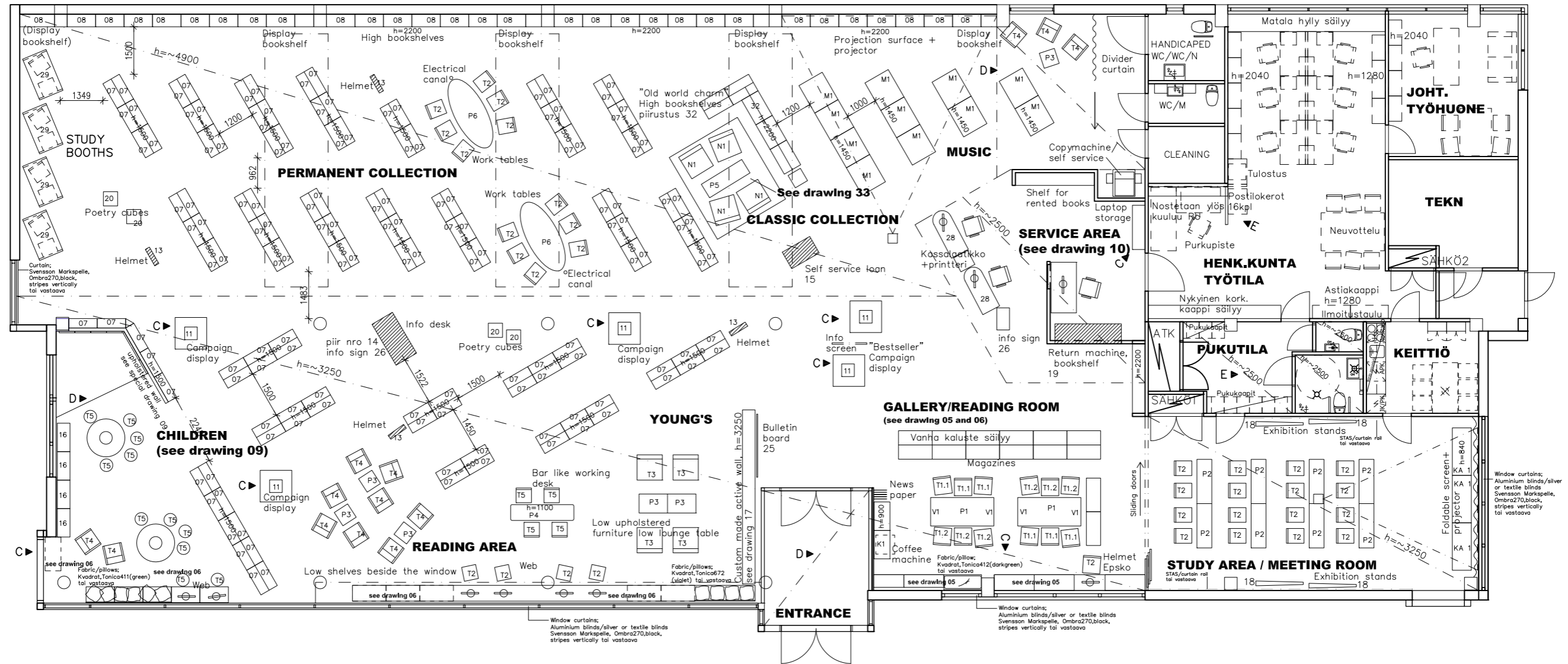

POHJA, 1:125

- E Pukuhuoneen ovet käännetty, henk.kunnan tilan purkupistettä muutettu 14.09.2010
- D Lattiakorotus, alakatto muutettu, alakattomerkinä lisätty 02.09.2010
- C Kalusteiden mittoja päivitetty 04.08.2010
- B Hlökunnan työtila, palvelualueen kassalaatikko, lukutilan kalusteet ja valaistus päivitetty, lukutilan Helmet siirretty ikkunan eteen 14.05.2010
- A Palvelualueen seinät lisätty, musiikkihyllyt päivitetty 26.04.2010

Rakennuskohteen nimi ja osoite <b>KIRJASTO OULUNKYLÄ</b>	Piirustuksen sisältö ja mittakaava <b>TYÖPIIRUSTUS</b> Pohjakuva <span style="float: right;">1:125</span>
<div style="display: flex; align-items: center;"> <div style="background-color: #808000; color: white; padding: 10px; margin-right: 10px; font-size: 24px; font-weight: bold;">06 KRS</div> <div>                     Pääsuunnittelija Pablo Riquelme                      Piirtänyt HPU                      Päiväys ja allekirjoitus 8.12.2009                 </div> </div>	piirustusno <b>SIS 01</b> <span style="float: right;">muutos <b>E</b></span>
kuudes kerros Malminkatu 30 a / 00100 helsinki, finland / www.kuudes.fi tel. +358 20 729 1717 / fax +358 20 729 1727	



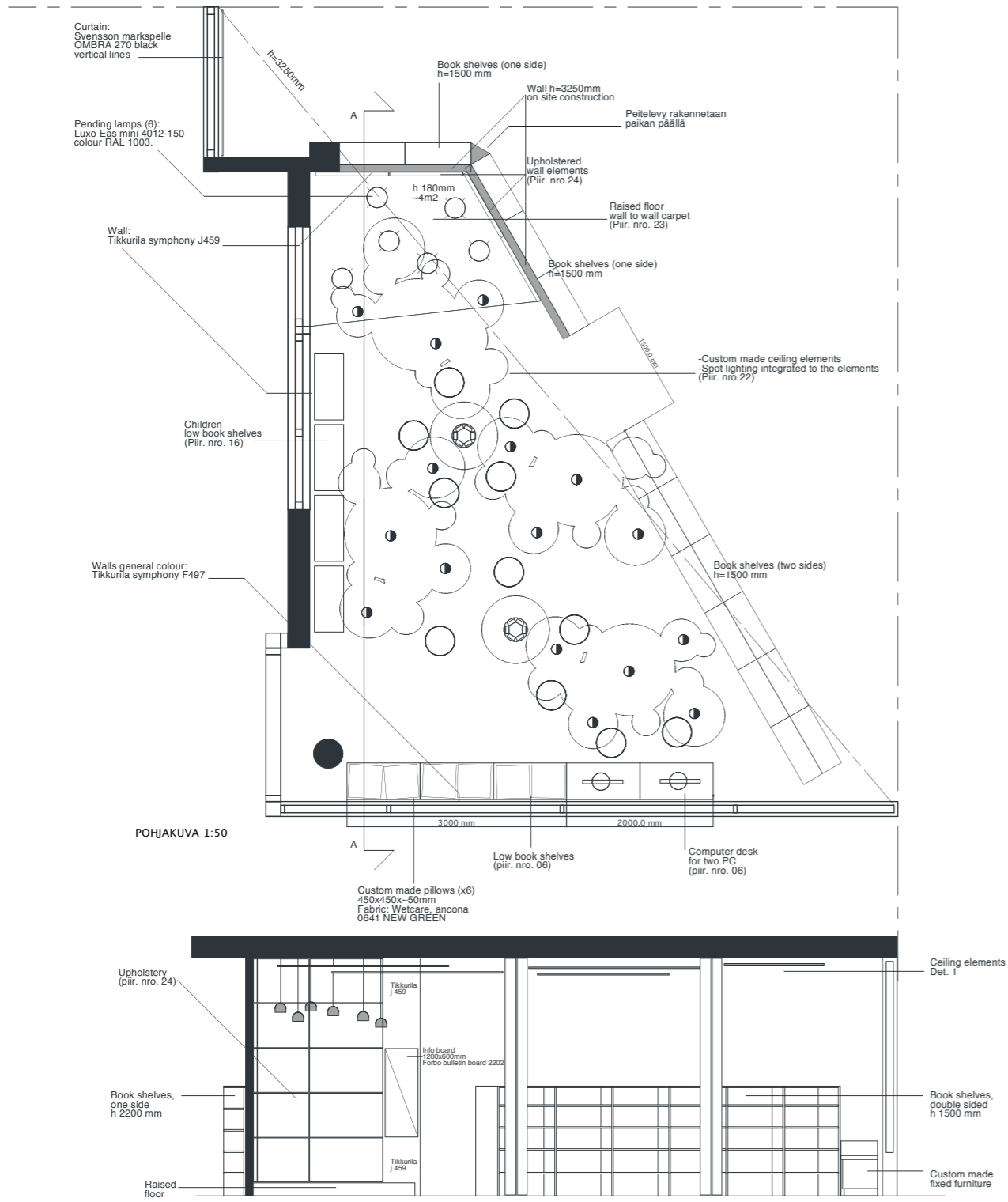

- C Children corner upholstery material 13.09.2010
- B Children corner wall measure (1500mm) 09.08.2010
- A Luxo EAS mini 4012-150 (Added colour RAL 1003) 12.05.2010

<b>KIRJASTO OULUNKYLÄ</b> Pääsuunnittelija Pablo Riquelme Piirtänyt PR 12052010 Päiväys ja allekirjoitus Kuudes kerros Oy Malminkatu 30 a / 00100 / Helsinki www.Kuudes.fi		Piirustuksen sisältö ja mittakaava <b>KALUSTEPIIRUSTUS</b> Children corner Pohjakuva, leikkaus A-A 1:50 piirustusno <b>SIS09</b> muutos <b>C</b>
--	--	--

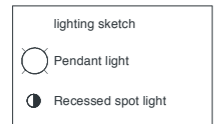

Oulunkylä library / Children area / Not in scale

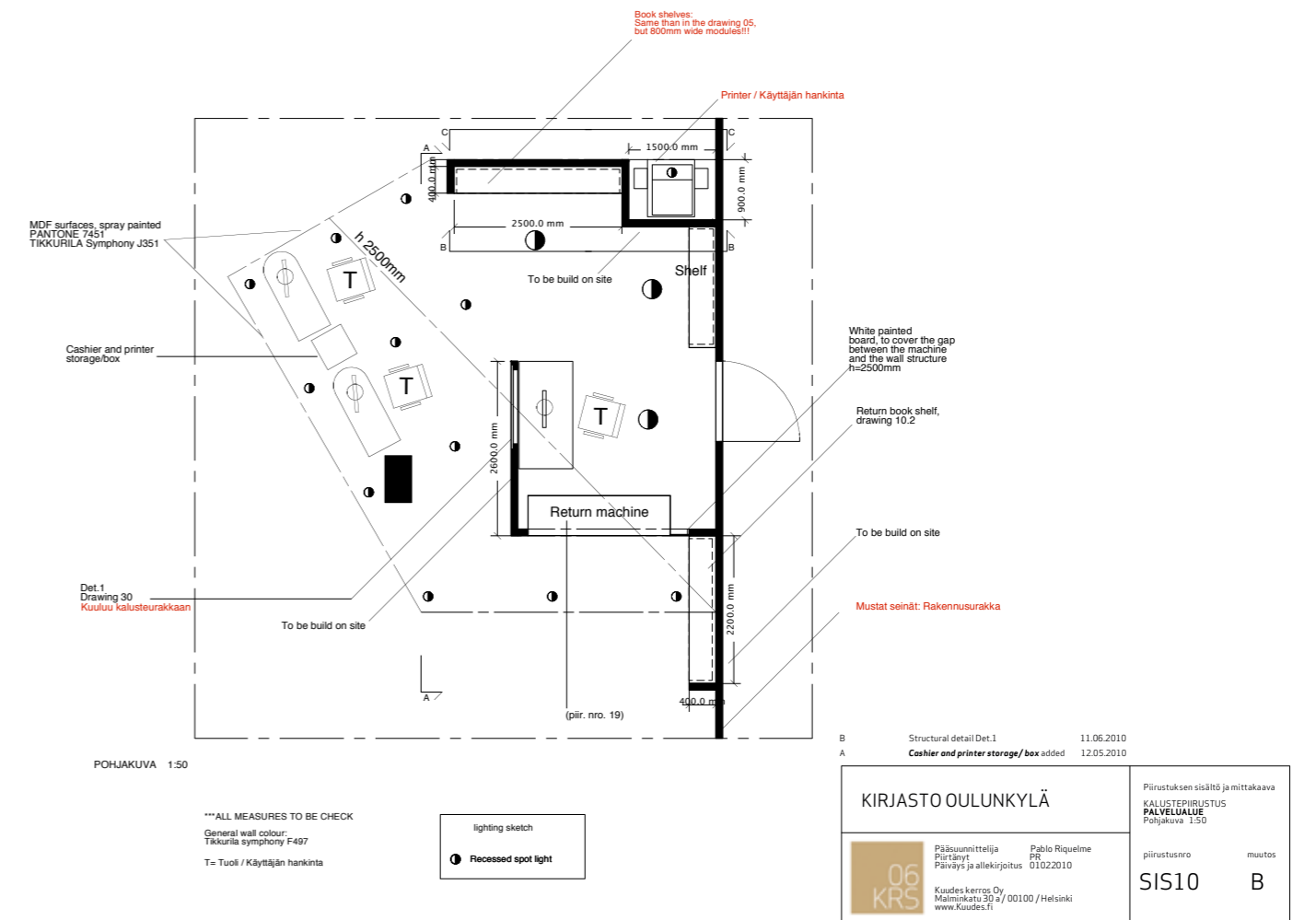

<b>KIRJASTO OULUNKYLÄ</b> Pääsuunnittelija Pablo Riquelme Piirtänyt PR 01022010 Päiväys ja allekirjoitus Kuudes kerros Oy Malminkatu 30 a / 00100 / Helsinki www.Kuudes.fi		Piirustuksen sisältö ja mittakaava <b>KALUSTEPIIRUSTUS</b> PALVELUALUE Pohjakuva 1:50 piirustusno <b>SIS10</b> muutos <b>B</b>
--	--	--

Oulunkylä library / Service area / Not in scale

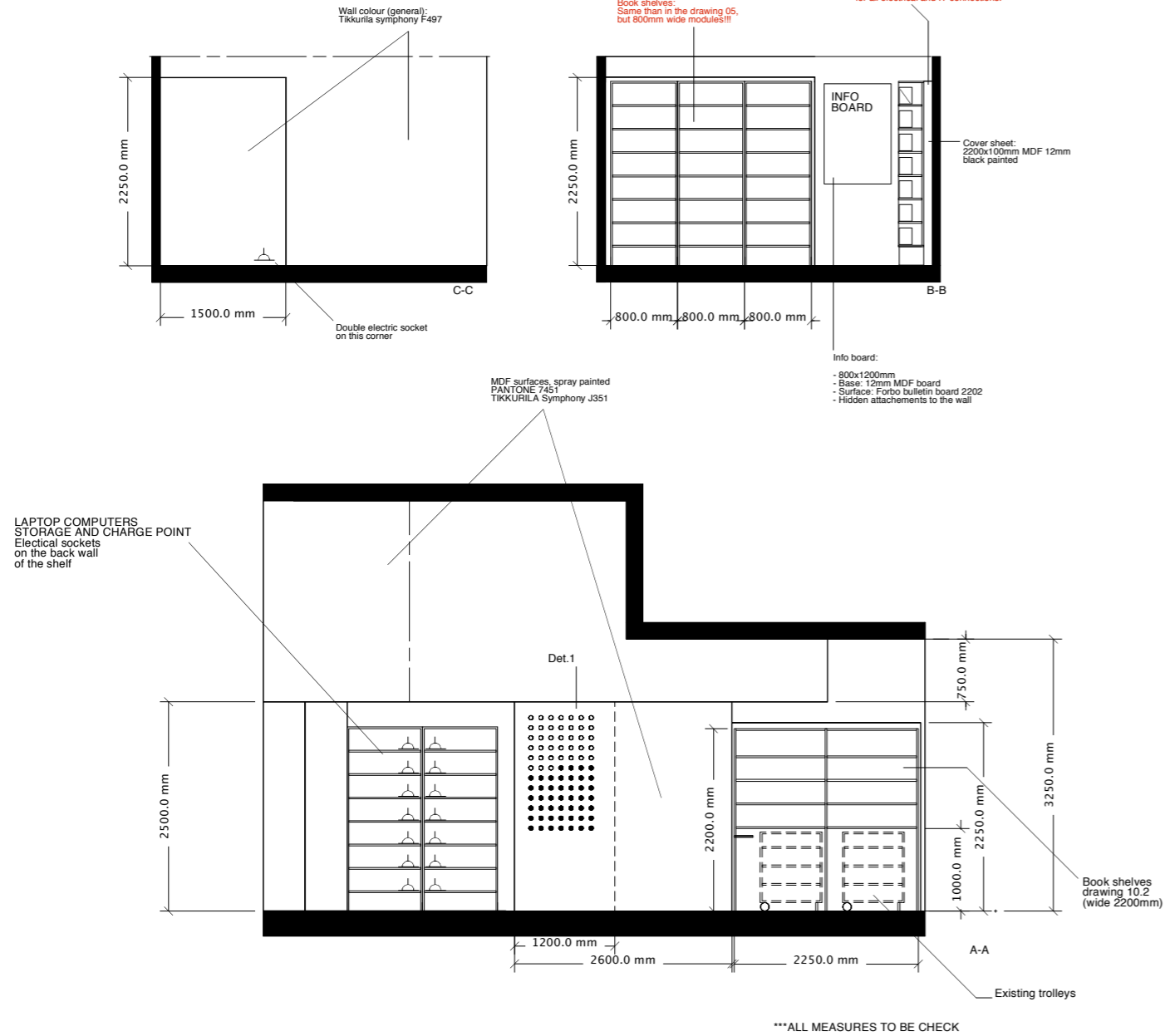

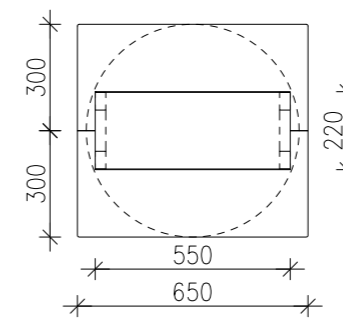
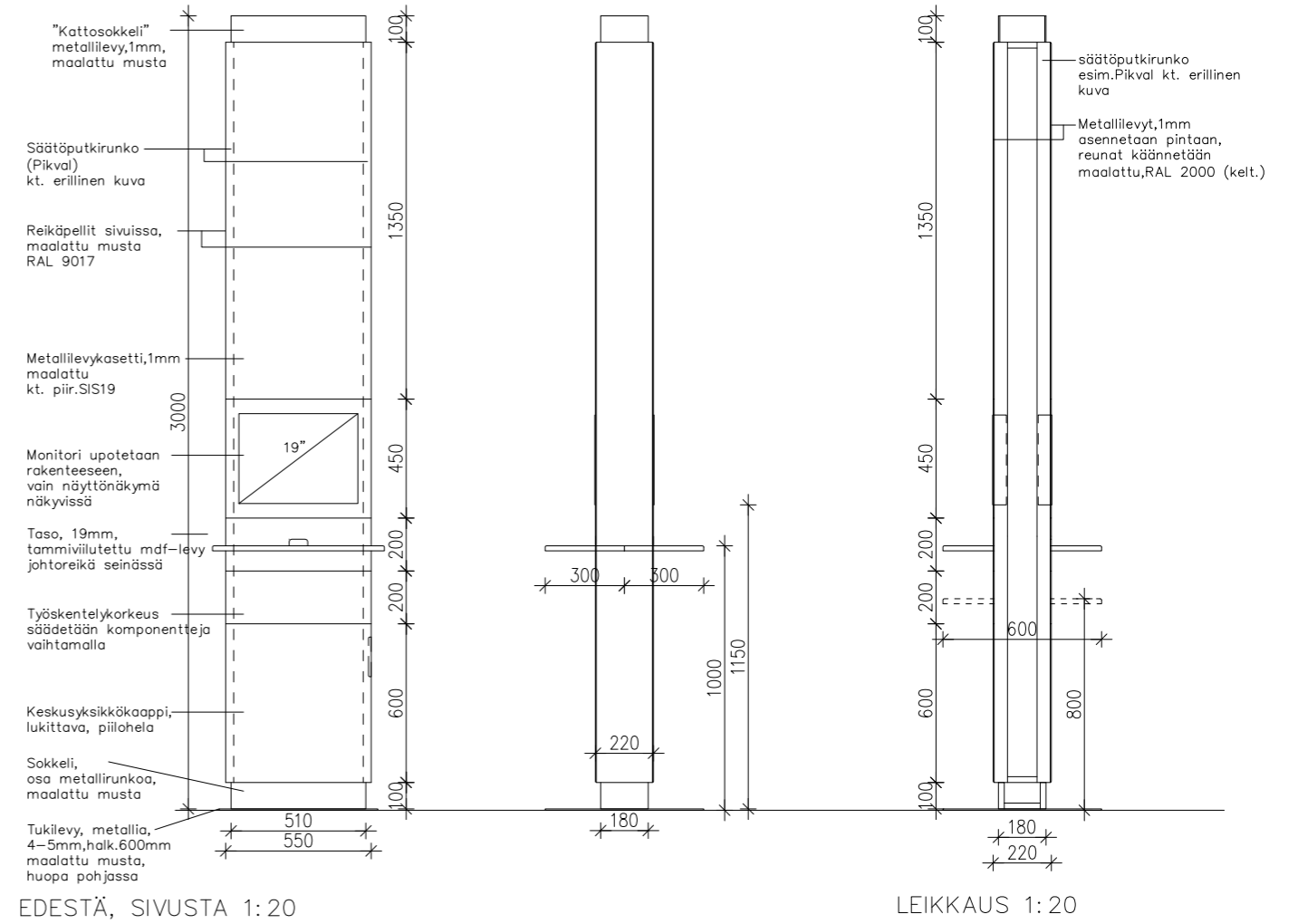

B Measures and shelves details 11.06.2010  
A Measures and shelves details 12.05.2010

<b>KIRJASTO OULUNKYLÄ</b> Pääsuunnittelija Pablo Riquelme Piirtänyt PR Päiväys ja allekirjoitus 01.02.2010 Kuudes kerros Oy Malminkatu 30 a / 00100 / Helsinki www.kuudes.fi		Piirustuksen sisältö ja mittakaava KALLUSTEPIIRUSTUS Service area leikkaus A-A, B-B, C-C 1:50 piirustusno muutos <b>SIS10.1 B</b>	
--	--	--	--

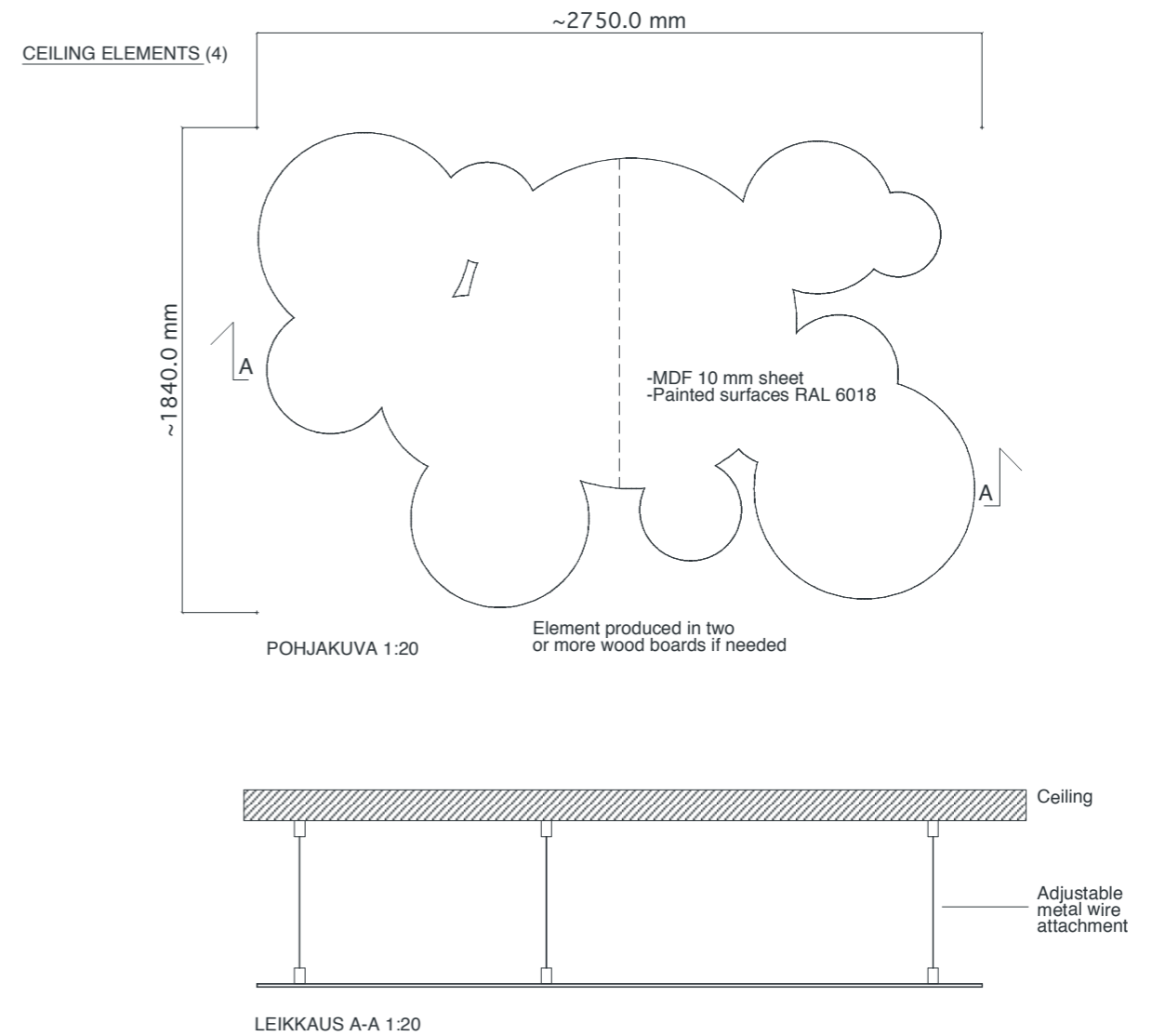
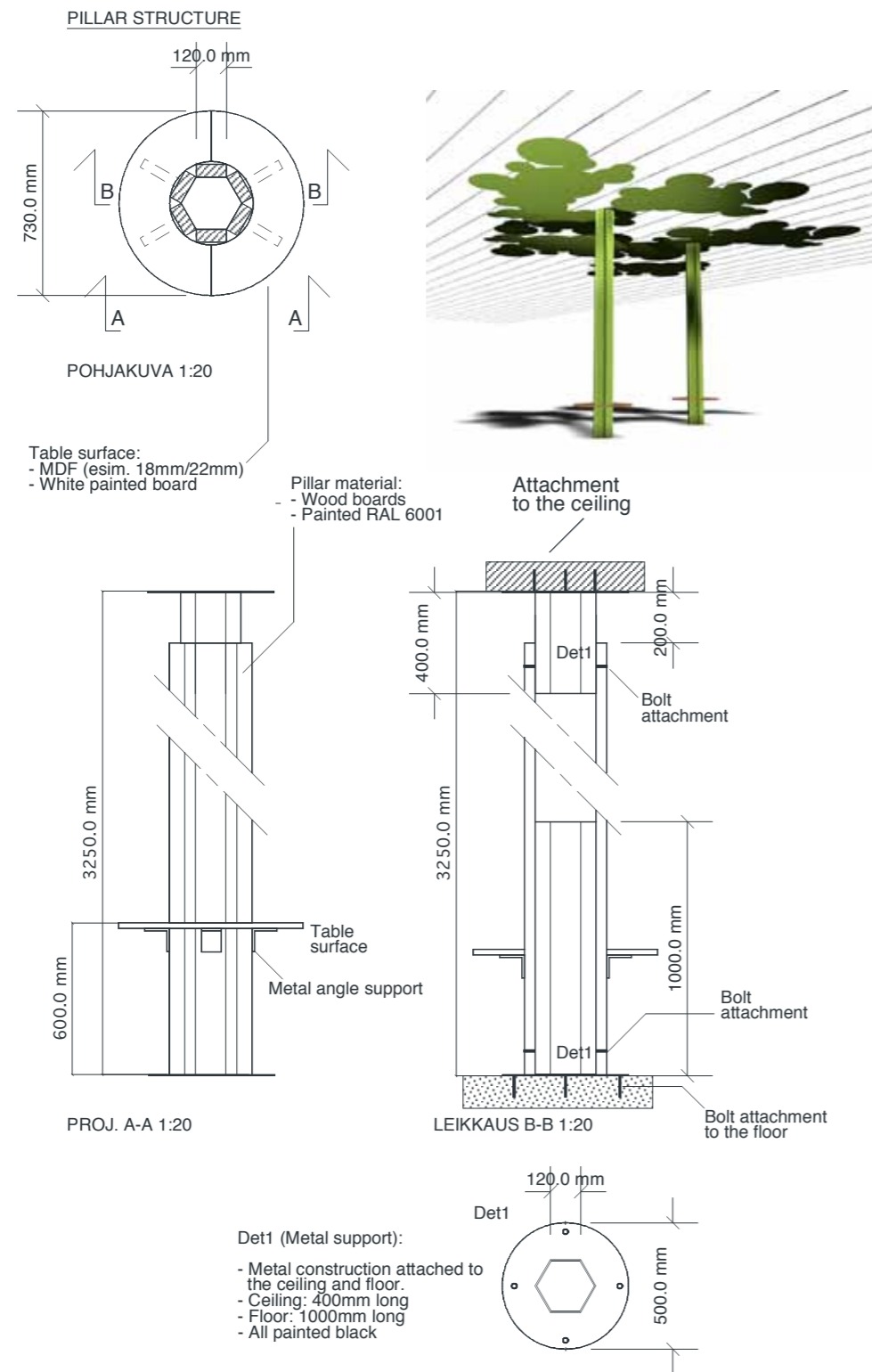

Leikkauskuva lisätty 11.06.2010 Rakennuksen nimi ja osoite <b>KIRJASTO OULUNKYLÄN</b> Helsinki		Piirustuksen sisältö ja mittakaava Kallustepiirustus HelMet Päässä Edestä, sivusta 1:10 1:20	
Pääsuunnittelija Pablo Riquelme Piirtänyt PR Päiväys ja allekirjoitus 01.02.2010 Kuudes kerros Malminkatu 30 a / 00100 Helsinki, Finland / www.kuudes.fi tel. +358 20 729 1717 / fax +358 20 729 1727		piirustusno muutos <b>13.1 A</b>	



A		Measures and details 11.06.2010
<b>KIRJASTO OULUNKYLÄ</b>		Piirustuksen sisältö ja mittakaava
		KALUSTEPIIRUSTUS <b>Lasten maailma DET1</b> Pillar structure Pohja: 1:20 Proj. A-A 1:20 Leikkaus B-B 1:20 Ceiling element Pohja: 1:20 Leikkaus A-A 1:20
		piirustusnro muutos <b>SIS22 A</b>
Pääsuunnittelija Piirtänyt Päiväys ja allekirjoitus	Pablo Riquelme PR 15.11.2009	
Kuudes kerros Oy Malminkatu 30 a / 00100 / Helsinki www.Kuudes.fi		





/ Photography © Kalle Kataila 2013

Oulunkylä library / Self service device  
Oulunkylä library / Service desk



/ Photography © Kalle Kataila 2013

Oulunkylä library / Collection area



/ Photography © Kalle Kataila 2013





/ Photography © Kalle Kataila 2013

Oulunkylä library / Children area



/ Photography © Kalle Kataila 2013

Oulunkylä library / Information desk



/ Photography © Kalle Kataila 2013

Oulunkylä library / Study booths



/ Photography © Kalle Kataila 2013

Oulunkylä library / HelMet self service point





/ Photography © Kalle Kataila 2013



Oulunkylä library / Youngsters area



/ Photography © Kalle Kataila 2013

Oulunkylä library / Magazine and news papers reading area





/ Photography © Kalle Kataila 2013

Oulunkylä library / Flexible area

# 7. BIBLIOGRAPHY

# 7. Bibliography

**Aaltonen Hanna** (2012): BTJ Finland Oy, Helsinki

**Edmonds Holt Leslie and Glen** (2010) Public libraries services for the poor, doing all we can: The American library association

**Mäkinen, Ilkka** (2009) Suomen yleisten kirjastojen historia: BTJ Finland Oy, Helsinki

**Höfer Candida** (2006) Libraries: Thames & Hudson

**Mäkinen, Ilkka** (2001) Finnish Public Libraries in the 20th Century: Tampere University press

## Digital sources

**Design Council UK, The role of design in public services:** <http://www.designcouncil.org.uk/our-work/insight/research/research-briefings/the-role-of-design-in-public-services/>

**Encyclopaedia Britannica,** <http://www.britannica.com/>

**Design Council UK, Design for public services (Why?):** <http://www.designcouncil.org.uk/about-design/types-of-design/service-design/design-for-public-services/>

**Danish Design Centre, The world is in the midst of a transition to a new age:** <http://en.ddc.dk/page/world-midst-transition-new-age>

**JISC, Designing Spaces for Effective Learning, A guide to 21st century learning space design:** [http://www.jisc.ac.uk/uploaded\\_documents/JISClearningspaces.pdf](http://www.jisc.ac.uk/uploaded_documents/JISClearningspaces.pdf)

**Kaupunginosat.net** [http://www.kaupunginosat.net/oulunkyla/kaupunkipolku/makitorppa/slides/m25\\_kirjasto.htm](http://www.kaupunginosat.net/oulunkyla/kaupunkipolku/makitorppa/slides/m25_kirjasto.htm)

**John Thackara, What Does Social Innovation Actually Mean?** <http://www.doorsofperception.com/handouts-2/what-does-social-innovation-actually-mean/>

**Wikipedia.com (2013) History of the library:** [http://en.wikipedia.org/wiki/History\\_of\\_libraries](http://en.wikipedia.org/wiki/History_of_libraries)

**Bailey Jocelyn (2012) Role of social design in public services:** <http://www.guardian.co.uk/public-leaders-network/2012/apr/18/social-design-public-services>

**Mark Lamster (2012) Still Here, Metropo- lismag.com:** <http://www.metropolismag.com/story/20120720/still-here>

**NYPL (2011), The future of the libraries, Bruno Racine & Paul Leclerc:** <http://www.nypl.org> [http://www.nypl.org/sites/default/files/.../RacineLeClerc\\_4.29Transcript.doc](http://www.nypl.org/sites/default/files/.../RacineLeClerc_4.29Transcript.doc)

**Mark Dudek (2000 (Digital version 2009) Architecture of Schools, The new learning environments, Architectural press:** [http://books.google.fi/books?hl=en&lr=&id=y-OuRbfHdkoC&oi=fnd&pg=PP2&dq=new+learning+environments&ots=T32lKNCXcQ&sig=jKdDksm2lP8s9yRhFOvnyfKxWqU&redir\\_esc=y](http://books.google.fi/books?hl=en&lr=&id=y-OuRbfHdkoC&oi=fnd&pg=PP2&dq=new+learning+environments&ots=T32lKNCXcQ&sig=jKdDksm2lP8s9yRhFOvnyfKxWqU&redir_esc=y)

**Mark Dudek (2000) Architecture of Schools, The new learning environments:** [http://books.google.fi/books?hl=en&lr=&id=y-OuRbfHdkoC&oi=fnd&pg=PP2&dq=new+learning+environments&ots=T32lKNCXcQ&sig=jKdDksm2lP8s9yRhFOvnyfKxWqU&redir\\_esc=y](http://books.google.fi/books?hl=en&lr=&id=y-OuRbfHdkoC&oi=fnd&pg=PP2&dq=new+learning+environments&ots=T32lKNCXcQ&sig=jKdDksm2lP8s9yRhFOvnyfKxWqU&redir_esc=y)

## Others sources (seminars)

**THE FUTURE OF LIBRARIES: BRUNO RACINE & PAUL LECLERC,** moderated by Paul Holdengräber, New York City Public Library, US 2011

**The new library "design and function" conference,** Helsinki Finland 2011



