

Joona Vehanen

Handover between LTE and 3G Radio Access Technologies: Test measurement challenges and field environment test planning

School of Electrical Engineering

Master's thesis submitted in partial fulfilment of the requirements for the degree of Master of Science in Technology in Espoo, 30.5.2011

Supervisor:

Prof. Jyri Hämäläinen

Instructor:

M.Sc Markku Pellava

Author: Joonas Vehanen

Title: Handover between LTE and 3G Radio Access Technologies: Test measurement challenges and field environment test planning

Date: 30.5.2011

Language: English

Number of pages: 8+78

Department of communications and networking

Professorship: Communications Engineering

Code: S-72

Supervisor: Prof. Jyri Hämäläinen

Instructor: M.Sc Markku Pellava

LTE (Long Term Evolution) is a fourth generation cellular network technology that provides improved performance compared to legacy cellular systems. LTE introduces an enhanced air interface as well as a flat, 'all-IP' packet data optimized network architecture that provides higher user data rates, reduced latencies and cost efficient operations.

The rollout of initial commercial LTE networks is likely based on service hot spots in major cities. The design goal is however to provide a universal mobile service that allows the subscribers to connect to both operator and Internet services anywhere anytime and stay connected as the users are on the move. To provide seamless service, mobility towards widespread legacy radio access technologies such as GSM and UMTS is required.

The research topic of this thesis is handover from LTE to 3G cellular networks, which is a high priority item to the operators that seek to provide an all-round service. To satisfy certain quality of service requirements this feature needs to go through a development process that consists of thorough functionality, performance and fault correction testing

This thesis introduces a plan for test execution and introduces the tools and procedures required to perform inter radio access technology handover tests. The metrics that indicate the network performance, namely Key Performance Indicators (KPIs), i.e. handover success rate, call drop rate, throughput and handover delay are introduced in detail. In order to provide reliable results, the plan is to perform the measurements in a field environment with realistic radio conditions. With the proper tools such as XCAL for air interface performance analysis, the field tests should provide results that are comparable to tests performed by the operators in live commercial LTE networks.

Keywords: LTE, 4G, I-RAT handover, handover success rate, field verification, performance measurement

Tekijä: Joonas Vehanen

Työn nimi: Handover between LTE and 3G Radio Access Technologies: Test measurement challenges and field environment test planning

Päivämäärä: 30.5.2011

Kieli: Englanti

Sivumäärä: 8+78

Tietoliikenne- ja tietoverkkotekniikan laitos

Professori: Tietoliikennetekniikka

Koodi: S-72

Valvoja: Prof. Jyri Hämäläinen

Ohjaaja: Fil. Maist. Markku Pellava

LTE (Long Term Evolution) on neljännen sukupolven matkapuhelinverkkoteknologia, joka tarjoaa paremman suorituskyvyn verrattuna perinteisiin matkapuhelinverkkoihin. Tehostettu ilmarajapinta sekä litteä, "puhdas-IP" -pakettidatalle optimoitu verkko-arkkitehtuuri tarjoavat parempia siirtonopeuksia ja lyhyempiä siirtoviiveitä käyttäjille, sekä operaattoreille kustannustehokasta toimintaa.

Ensimmäisten kaupallisten LTE-verkkojen käyttöönotto perustuu todennäköisesti paikallisverkkoihin suurissa kaupungeissa. Suunniteltuna tavoitteena on kuitenkin tarjota maailmanlaajuinen mobiilipalvelu, jonka avulla tilaajat saavat mistä vain ja milloin vain yhteyden sekä operaattorin, että Internetin tarjoamiin palveluihin, ja että yhteys myös pysyy päällä, kun käyttäjät ovat liikkeellä. Saumattoman palvelun tarjoamiseksi, solunvaihto LTE:n ja perinteisten radio-tekniikoiden kuten GSM:n ja UMTS:n välillä on välttämätön ominaisuus.

Tämän työn tutkimusaihe on aktiivinen solunvaihto LTE:n ja 3G matkapuhelinverkkojen, mikä on tärkeä toiminnallisuus operaattoreille, jotka pyrkivät tarjoamaan kattavaa mobiilipalvelua. Täytettäväksi tietyt palvelun laatua koskevat vaatimukset, tämän toiminnallisuuden täytyy käydä läpi kehitysprosessi, joka sisältää perusteellisen toiminnallisuus-, suorituskyky- ja viankorjaustestaamisen.

Tässä työssä esitellään testaus suunnitelma, sekä työkalut ja menetelmät testien suorittamiseen. Verkon suorituskykyä kuvaavat mittarit, kuten solunvaihdon onnistumisprosentti, yhteyden katkeamisprosentti, tiedonsiirtonopeus ja solunvaihdon viive esitellään yksityiskohtaisesti. Luotettavien tuloksien saamiseksi mittaukset suoritetaan kenttätesteinä, jotta radio-olosuhteet ovat realistisia. Oikeiden työkalujen avulla, kuten ilmarajapintaa analysoiva XCAL-ohjelmisto, voidaan tuottaa tuloksia, jotka vastaavat operaattorien tekemiä testauksia kaupallisissa LTE-verkoissa.

Avainsanat: LTE, 4G, radiotekniikoiden välinen aktiivinen solunvaihto, solunvaihdon onnistumisprosentti, kenttätestaus, suorituskyvyn mittaus

Acknowledgements

This thesis was done at Nokia Siemens Networks research and development site in Espoo, Finland. The research work was carried out on a time period between January 2011 and May 2011 as part of LTE end-to-end field verification work at NSN.

I would like to thank my instructor Markku Pellava and my supervisor professor Jyri Hämäläinen for their support throughout my thesis work. I would also like to thank all my colleagues at NSN for their friendly and helpful attitude towards my work. Special thanks go out to Antti Reijonen, Leo Bhebhe, Heikki Ruutu, Jari Salo and Marko Kotilainen for their inputs to my research. Thanks go out also to all of my friends and family for cheering me up during my writing process.

Finally I would like to express my gratitude to my parents for their patience and support throughout my studies.

Espoo, May 2011

Joona Vehanen

Table of contents

Abbreviations	v
List of figures.....	vii
List of tables.....	vii
1. INTRODUCTION.....	1
1.1 Problem Statement	2
1.2 Goals of the thesis	3
1.3 Scope and limits of the thesis.....	4
1.4 Research methods	5
1.5 Thesis outline	6
2. LONG TERM EVOLUTION OF 3GPP	7
2.1 Introduction to LTE	7
2.2 Requirements for UTRAN evolution.....	9
2.3. Evolved System Architecture	11
2.4 LTE Air interface concepts	13
2.5 LTE protocol structure and main tasks	18
3. MOBILITY.....	25
3.1 Introduction to mobility	25
3.2 Intra LTE handovers	30
3.3 Inter Radio Access Technology handovers.....	34
4. LTE FUNCTIONALITY AND PERFORMANCE TESTING.....	41
4.1 Introduction to LTE performance testing and system verification	41
4.2 Tools and methods for testing.....	44
4.3 Challenges in LTE end-to-end testing	50
5. TEST PLAN FOR FIELD ENVIRONMENT I-RAT HANDOVERS.....	53
5.1 Presenting the I-RAT handover field environment test plan	53
5.2 Plan for test execution.....	58
5.3 KPI measurements for I-RAT handovers	60
6. CONCLUSIONS AND FUTURE WORK.....	70
6.1 Conclusions.....	70
6.2 Future work.....	71
REFERENCES.....	72
APPENDIX.....	75

Abbreviations

3G	3rd Generation (Cellular Systems)
3GPP	3rd Generation Partnership Project
4G	4th Generation (Cellular Systems)
ACK	Acknowledgement
AM	Acknowledged mode
ARQ	Automatic Repeat Request
BCH	Broadcast Channel
BLER	Block Error Ratio
CAPEX	Capital Expenditures
CDMA	Code Division Multiple Access
CINR	Carrier to Interference plus Noise Ratio
CRB	Control Radio Bearers
CS FB	Switched Fall Back
DL-SCH	Downlink Shared Channel
DRB	Data Radio Bearers
eNodeB	Evolved Node B
EPC	Evolved Packet Core
EPS	Evolved Packet System
E-UTRAN	Evolved Universal Terrestrial Radio Access Network
FDD	Frequency Division Duplex
FEC	Forward Error Correction
FiVe	Field Verification
GERAN	GSM EDGE Radio Access Network
GPRS	General Packet Radio Service
HARQ	Hybrid Automatic Repeat Request
HSPA	High Speed Packet Access
HSS	Home Subscriber Server
I&V	Integration and Verification
ICI	Inter Carrier Interference
ICIC	Inter Cell Interference Coordination
IP	Internet Protocol
I-RAT	Inter Radio Access Technology
I-HSPA	Internet-HSPA (also Evolved HSPA or HSPA+)
ISHO	Inter-system Handover
ISI	Inter Symbol Interference
ITU	International Telecommunications Union
LTE	Long Term Evolution
MAC	Medium Access Control
MCH	Multicast Channel
MCS	Modulation and Coding Scheme
MIMO	Multiple Input Multiple Output
MISO	Multiple Input Single Output
MME	Mobility Management Entity
NACC	Network Assisted Cell Change
NACK	Negative Acknowledgement
NAS	Non-access Stratum

NRT	Non Real Time
O&M	Operation and Maintenance
OFDM	Orthogonal Frequency-Division Multiplexing
OFDMA	Orthogonal Frequency-Division Multiple Access
OMS	Operation Management System
OPEX	Operating Expenditures
PAPR	Peak-to-Average Power Ratio
PCH	Paging channel
PCRF	Policy and Charging Resource Function
PDCCH	Physical Downlink Control Channel
PDCP	Packet Data Convergence Protocol
PDU	Payload Data Units
P-GW	Packet Data Network Gateway
PHY	Physical Layer
PUCCH	Physical Uplink Control Channel
QoS	Quality of Service
QCI	QoS Class Indicator
RACH	Random Access Channel
RB	Radio Bearer
RF	Radio Frequency
RLC	Radio Link Control
RNC	Radio Network Controller
RoHC	Robust Header Compression
RRC	Radio Resource Control
RRM	Radio Resource Management
RSRP	Reference Signal Received Power
RT	Real Time
SAE	System Architecture Evolution
SC-FDMA	Single Carrier Frequency Division Multiple Access
SCT	System Component Testing
SGSN	Serving Gateway Support Node
S-GW	Serving Gateway
SIMO	Single Input Multiple Output
SISO	Single Input Single Output
SON	Self Organizing Networks
SR-VCC	Single Radio Voice Call Continuity
SyVe	System Verification
TDD	Time Division Duplex
TM	Transparent Mode
TTI	Transmit Time Interval
TTT	Time To Trigger
UE	User Equipment
UL-SCH	Uplink Shared Channel
UMTS	Universal Mobile Telecommunications System
UM	Unacknowledged Mode
USIM	Universal Subscriber Identity Module
UTRAN	Universal Terrestrial Radio Access Network

List of figures

Figure 1: Evolution from 3G to LTE and beyond [13].....	8
Figure 2: High level architecture of 3GPP LTE [18].....	12
Figure 3: LTE Air interface techniques [19].....	14
Figure 4: OFDMA transmitter and receiver [1].....	14
Figure 5: SC-FDMA transmitter and receiver [1].....	16
Figure 6: Multiple antenna techniques [20].....	17
Figure 7: User plane protocol stack in EPS [1].....	18
Figure 8: Control plane protocol stack in EPS [1].....	18
Figure 9: Mapping of Transport channels to physical channels [9].....	20
Figure 10: Channel-dependent scheduling in time <i>and</i> frequency domains [13].....	21
Figure 11 Radio interface protocols [24].....	22
Figure 12: E-UTRA states and inter-RAT mobility procedures [17].....	29
Figure 13: Handover triggering procedure [6].....	32
Figure 14: Roaming architecture for intra-3GPP access [17].....	35
Figure 15: E-UTRAN to UTRAN Inter RAT HO, preparation phase [17].....	37
Figure 16: E-UTRAN to UTRAN Inter RAT HO, execution phase [17].....	39
Figure 17: Cell Capacity (Mbps) (BLER considered).....	47
Figure 18: Screenshot of signaling and measurement Figures with an XCAL tool.....	48
Figure 19: LTE field network and I-RAT Handover locations.....	54
Figure 20: XCAL captured signaling flows for successful and unsuccessful intra-LTE handover scenarios.....	61
Figure 21: Analysis on the u-plane transient period [42].....	65
Figure 22: User active mode mobility in a cellular network [46].....	75
Figure 23: Inter eNB Handover signaling [9].....	76
Figure 24: Wireshark packet capture from UE side highlighting measured intra-LTE X2 based handover interruption time [40].....	77
Figure 25: I-HSPA radio condition measurement with Nemo-tool in handover point C.....	78

List of tables

Table 1: Evolution from 3G to 4G [15].....	9
Table 2: User mobility scenarios.....	28
Table 3: Event triggered reports for E-UTRA and inter-RAT measurements [1].....	30
Table 4: Planned I-RAT field handover points.....	57
Table 5: Assumptions for LTE-3G handover interruption time [42].....	65
Table 6: Planned measurement KPIs and measurement tools.....	69

1. INTRODUCTION

Since the introduction of High Speed Downlink Packet Access (HSDPA) in Third Generation (3G) cellular networks, the usage of mobile user data has been growing at almost an exponential rate. Mobility allows the users to connect conveniently to the operator services, usually including the Internet, almost anywhere they go and even stay connected as they move. Legacy cellular systems, including second generation systems like Global System for Mobile Communications (GSM) and third generation systems like Universal Mobile Telecommunications System (UMTS) are however designed for voice optimized performance, and are relatively expensive to operate. Soon after the release of HSDPA and later 3G releases it became clear that there will already soon be a need for a next generation cellular system. This was due to the fact that mobile data traffic had already exceeded voice traffic in volume and the trend of growth in data traffic had no signs of saturating any time soon.

At this point it was seen that the next generation system should be a data optimized system providing even more capacity and higher data rates than HSDPA. At the same time flat rate pricing models were pushing the operators to minimize their expenses and utilize their licensed radio spectrum more efficiently. The demand finally resulted in a study item in 2004 that examined the potential candidates for a next generation radio access system. The principal requirement was that this system would be capable of satisfying the increasing data traffic and performance demand even in the long run. Consequentially this technology was named Long Term Evolution (LTE). [1]

LTE is considered a fourth generation technology and an evolution of the third generation mobile network technology. It was designed to meet the need for increased capacity and enhanced performance. The main differences to 3G systems are a packet data optimized, cost efficient 'all-IP' architecture and an evolved, spectrally efficient air interface. Voice connectivity remains an important feature but since there is no circuit switched domain in LTE, voice connectivity is based on Voice over IP (VoIP) on top of packet switched IP-protocol.

LTE is standardized by Third Generation Partnership Project (3GPP), which is an entity established in collaboration by a number of telecommunications standards bodies, e.g. ETSI in Europe and ATIS in North America [2]. LTE as well as GSM and WCDMA are all a part of the 3GPP family of technologies that serve nearly 90% of the mobile subscribers globally.

3GPP2 systems such as CDMA and EVDO then serve less than 10% of subscribers [1]. The coverage area of 3GPP radio access networks today spans almost the entire globe. At the time of writing this thesis there are already several commercial LTE networks, for example in the cities of Gothenburg [3] and Stockholm in Sweden as well as several major cities in Germany. Network technology development is however at an early stage and feature implementation is ongoing.

1.1 Problem Statement

Users are likely to expect uninterrupted, efficient and stable service starting from the day they buy their LTE device. After all, potential customers can already get a stable mobile network service with e.g. a HSPA device, which however does not provide as good performance. Reliable and fast Internet services as such, are also offered by high speed Ethernet and WLAN connections. Mobility is really the feature that is distinctive of those technologies since Ethernet offers only a fixed connection and WLAN is more of a local wireless connection service. Wireless connection and the ability to communicate conveniently nearly anywhere are really the competitive advantages in Public Land Mobile Networks (PLMN). LTE even provides a competitive performance compared to fixed connections on top of the convenience of user mobility.

It is however expected that the initial rollout of LTE Evolved Universal Terrestrial Radio Access Networks (E-UTRAN) is in many cases based on service hot spots that cover relatively small geographical areas. It is also evident that the full scale rollout of LTE will take a considerable time, and the legacy systems will be there to serve the current mobile users for years to come. For these reasons, to actually provide seamless mobility and uninterrupted service, mobility across radio access technologies is required. As 3GPP family of technologies are dominating the wireless access networks and span most of the globe, we can finally establish how valuable a feature for mobility support within 3GPP family of technologies, namely Inter Radio Access Technology (I-RAT) mobility, is for the operators. Rollout scenarios for operator LTE networks are discussed e.g. in [4] and [5].

For nomadic users, idle state mobility including Inter-RAT mobility is sufficient. The requirements for idle state mobility are however much looser than for connected mode handovers. Measurements for delay and success rate are not that interesting as long as they are at a tolerable level and service continuity is assured. To provide actual mobility with unnoticeable service interrupt times and seamless service, as promised in 3GPP LTE

specifications, also delay efficient and high success rate, connected mode Inter-RAT handover feature is required. This enables seamless service that may not be provided merely by LTE at the beginning. The feature needs to satisfy certain conditions, namely a reasonable handover success- and call drop ratio. A successful handover procedure also needs to satisfy handover delay requirements so that the quality of user services is not degraded. The user throughput should remain at a level that is above the user service requirements both before and after the handover. The targets for these performance requirements are set in 3GPP standards. However vendors and operators may also have set targets of their own, according to their provided service and application requirements. To reach these requirements, feature development through thorough performance, functionality and fault correction testing is required on the vendor side.

This thesis studies the functionality and performance testing of Inter Radio Access Technology handovers from LTE to legacy 3GPP cellular networks. Backwards compatibility to both 2G and 3G networks is important since they are already widespread. However the focus of the discussion is handovers towards 3G networks since this is seen as a high priority item. This is a technical document but understanding the backgrounds, the commercial aspects, and operator- as well as end-user needs, such as seamless mobility presented in this introduction is still important. Understanding the context is critical in end-to-end system testing related to this thesis work so that certain features and test cases can be prioritized according to customer demand. [5]

1.2 Goals of the thesis

The main goal of this thesis is to provide a test plan for Inter Radio Access Technology handover performance testing. The challenges that test engineers are likely to face in I-RAT handover testing are analyzed and a test plan for field environment test execution is presented. There is little research work done in the field of I-RAT handovers from LTE to legacy 3GPP networks and therefore a clear and thorough documentation of this feature given in this thesis can be considered as one important goal of this thesis and the contribution to the academic community. One of the biggest challenges in testing work is that test engineers are not aware of how exactly the tests should be executed and what is the wanted behaviour of the network elements. Therefore providing the exact methods for performing the I-RAT handover test work will ensure that the tests are done correctly and therefore the test results are reliable and valid for further analysis.

The initial goal of the thesis was to perform measurements for Key Performance Indicator (KPI) values for 4G E-UTRAN to 3G UTRAN I-RAT packet switched handovers. Due to limitations in e.g. the terminal equipment, it however became evident that these measurements could not be performed within the time frame given for completing the thesis. Therefore the scope of this thesis is limited to test planning and analysis of challenges in the test process. The methods and tools for performing the measurements for the KPIs as listed below are explained in detail so that once the testing is possible; test engineers can perform the measurements with the instructions given in this thesis. The test procedures for the following KPIs are presented in this document:

- **Handover success rate**
- **Handover delay**
- **Call drop rate**
- **Throughput**

1.3 Scope and limits of the thesis

- The original goal of the thesis was to perform I-RAT handover KPI measurements. Performing these tests were however not possible at the time of writing this thesis and therefore the scope is limited to test planning and analysis of the challenges test engineers are likely to face in I-RAT handover testing.
- The main outcome of this thesis is the analysis of I-RAT handover performance testing specifically from LTE to 3G. Handovers towards the other direction are not seen as that high priority of an item according to interviews, and therefore these test measurement procedures will not be discussed in detail. This is because we can assume that 3G networks cover also the LTE hotspot areas and thus 3G service continuity can be assured without handovers from 3G to 4G.
- Measurement procedures towards 2G networks are introduced briefly in theory but the discussion of the practical part is limited since LTE-2G handover feature may not be supported with the current vendor implementation.
- The literature study part is for the most part LTE related as some knowledge of legacy cellular mobile networks is expected.

- The reader is expected to be familiar with the cellular concept and fundamental radio access technologies. Basics of networking technologies and the TCP/IP protocol stack are also expected to be known so these concepts won't be explained in detail here.
- The terms I-RAT and Inter-technology handovers are used interchangeably in literature. The term I-RAT handover used in this thesis refers to handovers between E-UTRAN and UTRAN or GERAN. Inter-system handover (ISHO) has then traditionally been the used term for handovers between UTRAN and GERAN. The term Inter-Technology handover refers to handovers to technologies outside of 3GPP.
- The terms 4G, 3G and 2G can refer to many different technologies, e.g. WiMaX is considered a 4G technology as well as LTE. In this document for simplicity, these technologies refer to 3GPP family of technologies that are LTE, WCDMA/HSPA and GSM/GPRS for 4G, 3G and 2G technologies respectively.
- There has been little research work published so far in I-RAT handover performance testing. Therefore presenting and publishing the documented results is hopefully helpful in future research. Related test work has been done previously for intra-LTE handovers in [6] and for 3G-2G ISHO handovers in [7] and [8].

1.4 Research methods

This thesis combines both qualitative and quantitative research. The literature study is based on 3GPP standards and books that are written based on these standards. Technical whitepapers and related conference documents are also used as references. The research subjects such as the physical network elements and the logical network interworking procedures are defined at a high level of abstract in the literature study part. This means that exact mathematical descriptions or practical system hardware and software implementations are outside the scope of this document. The causes and reasons behind the study subjects are investigated but also analysis based on numerical data and statistics is performed, i.e. analysis of KPI values as indicators of network performance.

The practical part of the thesis is based on study of the research subjects through interviews and research work in collaboration with colleges. The tools and methods for the measurements as well as a practical handover test plan based on performed coverage measurements will be introduced.

1.5 Thesis outline

The performed research work is a part of end-to-end system verification and new feature testing. Understanding the technology concepts and standards is essential to be able to perform related test work. Knowledge of the specifications and requirements for functionality and performance is equally important to know if the technology implementation satisfies the conditions set for it in the standards. Therefore this thesis will provide an extensive overview of the technology concepts before going in to the theory and practical discussion of I-RAT handover test measurements and planning researched in this thesis.

The contents of the first part of this thesis, which is the literature study part, are as follows. Chapter 2 introduces LTE in general as a fourth generation mobile network technology. Chapter 3 then focuses on mobility aspects within LTE as well as interworking with legacy cellular systems. The second part of the thesis including Chapters 4 and 5 is then the practical part. Chapter 4 presents the tools and methods for performing LTE end-to-end system verification in general. Then Chapter 5 presents a more detailed discussion of the tools and methods as well as an execution plan to performing Inter Radio Access Technology handover test measurements. Finally Chapter 6 provides a conclusion to the work done in this thesis and considerations for future work.

2. LONG TERM EVOLUTION OF 3GPP

This chapter gives an overview of 3GPP Long Term Evolution as a fourth generation mobile network technology and explains the key concepts used in LTE. The specifications alone for this completely new cellular radio system consist of thousands of pages. In addition there is a vast amount of white papers, conference papers and entire books written merely about LTE theory. Due to the length constraint of this thesis, this chapter provides only a brief introduction to LTE and tries to focus on the most important issues related to I-RAT handovers. A more detailed overall description of LTE E-UTRAN is given in 3GPP specification TS 36.300 [9].

The contents of this chapter are as follows. Chapter 2.1 discusses the background and motivations for LTE and gives an overview of the technology concepts. Then Chapter 2.2 goes on to list the requirements set for the new mobile network technology. Finally Chapters 2.3-2.5 go deeper in explaining the technology concepts such as evolved system architecture, air interface concepts and protocol architecture.

2.1 Introduction to LTE

2.1.1 Background

The work towards LTE standardization started in November 2004 in a 3GPP Radio Access Network (RAN) Evolution Workshop in Toronto, Canada. As a result a study item was created for developing a framework and defining the targets for evolution of 3GPP radio access technology. Feasibility study for LTE E-UTRAN is given in a 3GPP document TR 25.912 [10]. This study was done to ensure the long term competitiveness of 3GPP technology, which was seen necessary even though HSDPA technology was not yet deployed at that time. The specification work was considered complete five years later in March 2009 as the specifications for the evolved core network called System Architecture Evolution (SAE), were included and backwards compatibility to existing radio access technology was ensured. Today there are several live commercial LTE networks e.g. in Sweden and Germany. New LTE networks can be expected since the operators have shown great interest towards LTE technology. [1], [11]

The first LTE release in 3GPP standards and the one studied in this thesis is Release 8. According to International Telecommunications Union (ITU), LTE did not originally satisfy the requirements set for a 4G technology. ITU considered that Release 10, namely LTE-

Advanced, would be the first 3GPP release to satisfy the requirements for an IMT-Advanced or 4G technology. The operators however weren't happy with "pre-4G" or "3.9G" labels and were advertising their LTE networks as fourth generation mobile networks. In December 2010 as a result of pressure from the operators, ITU declared in a press release that LTE as well as WiMaX and HSPA+ can officially be called 4G technologies [12]. The roadmap for 3G evolution in 3GPP and the way towards 4G is illustrated in Figure 1.

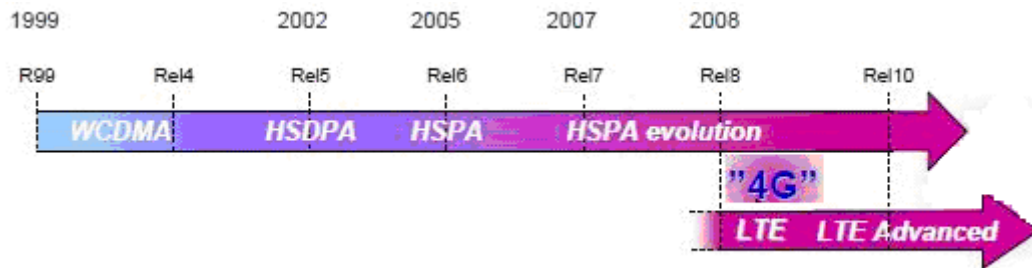

Figure 1: Evolution from 3G to LTE and beyond [13]

2.1.2 Evolution from third generation cellular systems

The main motivation for LTE deployment is based on rapid growth in mobile data usage. Increased demand for high user data rates, lower latencies and operator demand for more capacity and efficient usage of the scarce radio spectrum are the driving forces behind the technology development. Flat rate pricing models for broadband subscriptions also create pressure for operators to minimize their cost per bit expenses as well as their network maintenance costs [1]. These issues have been tackled on several levels in both the radio access part of LTE, E-UTRAN, and the core network, SAE. LTE network elements support the monitoring of user data traffic, which makes other pricing models available for the operators. Flat rate pricing models are however preferred at least in the beginning as they are critical for LTE mass market adoption. [14]

LTE inherits the cellular concept and many of its features from legacy systems in 3G cellular technologies but it also introduces a whole set of new concepts and features. Code Division Multiple Access (CDMA) used in third generation systems has been replaced by Orthogonal Frequency Division Multiple Access (OFDMA) as the multiple access method in downlink due to its good spectral properties and bandwidth scalability. OFDMA is well compatible with Multiple Input Multiple Output (MIMO) multi-antenna transmission techniques used in LTE. The downside of OFDMA is that it introduces a high Peak-to-Average Power Ratio (PAPR) in the transmitter side. This increases transmitter complexity and power consumption, which is a critical factor in the mobile terminal side. Therefore a multiple access scheme that

minimizes the terminal power consumption, namely Single Carrier Frequency Division Multiple Access (SC-FDMA), was chosen for uplink. These schemes will be explained in detail later in this chapter. Some of the most important LTE features are summarized below.

- OFDMA as downlink multiple access method provides orthogonality among users and along with multiple-antenna techniques a good spectral efficiency.
- LTE provides frequency flexibility as it has been allocated 17 paired and 8 unpaired bands with scalable bandwidth allocations of 1.4MHz to 20MHz.
- Enhanced air interface concepts as well as a flat ‘All-IP’ core architecture provide higher data rates and lower latencies with cost efficient operation.
- Seamless interoperability with legacy 3GPP systems.

Peak data rates in LTE release 8 are around 100Mbps in downlink and 50Mbps in uplink per cell. Latency is reduced to approximately 10ms in round trip times. These figures are a significant improvement from those of High Speed Packet Access (HSPA) not to mention earlier 3G or 2G releases. The evolution from third generation to fourth generation systems in terms of performance indicators such as data rates and latency are summarized in Table 1. [1]

Table 1: Evolution from 3G to 4G [15]

	WCDMA (UMTS)	HSPA HSDPA / HSUPA	HSPA+	LTE
Max downlink speed bps	384 k	14 M	28 M	100M
Max uplink speed bps	128 k	5.7 M	11 M	50 M
Latency round trip time approx	150 ms	100 ms	50ms (max)	~10 ms
3GPP releases	Rel 99/4	Rel 5 / 6	Rel 7	Rel 8
Approx years of initial roll out	2003 / 4	2005 / 6 HSDPA 2007 / 8 HSUPA	2008 / 9	2009 / 10
Access methodology	CDMA	CDMA	CDMA	OFDMA / SC-FDMA

2.2 Requirements for UTRAN evolution

2.2.1 General design requirements

This chapter lists the main requirements and targets set for LTE, as specified by 3GPP in TR 25.913. The objective for defining the LTE design requirements in general was to achieve significantly improved performance as compared to HSPA release 6. Key requirements for Long Term Evolution according to 3GPP [16] are as follows:

- Peak user data rate of 100Mbps in downlink with 20MHz spectrum allocation and 2 transmit antennas at the eNodeB and 2 receive antennas at the UE.
- Peak user data rate of 50Mbps in uplink with 20 MHz spectrum allocation and 1 transmit antenna at the UE and 2 receive antennas at the eNodeB.
- In a loaded network, target spectrum efficiency of 2-4 times (bits/sec/Hz/site) that of HSPA release 6.
- Support of flexible transmission bandwidth of up to 20MHz as compared to 5MHz in 3G systems.
- Minimization of latency in control plane so that transition from idle state to active state is less than 100ms.
- One way user plane latency in active mode of less than 5ms.
- Support of both Frequency Division Duplex (FDD) and Time Division Duplex (TDD) mode of operation.
- Reduced network CAPEX and OPEX for operators.

2.2.2 Requirements for Inter Radio Access technology handovers

Additional requirements that are related to the Inter Radio Access Technology handover measurement work done in this thesis are listed below. Basically the requirements state that handover related measurements and handovers should be supported to 3G Universal Terrestrial Radio Access Network and 2G GSM EDGE Radio Access Network (GERAN). There are also limits to service interruption times during these handovers. The requirements are tougher for delay sensitive real-time services than for non real-time services. The requirements related to I-RAT handovers are summarized below as quoted from TR 25.913. LTE should be able handle these requirements quite easily.

- ‘E-UTRAN Terminals supporting also UTRAN and/or GERAN operation should be able to support measurement of, and handover from and to, both 3GPP UTRA and 3GPP GERAN systems correspondingly with acceptable impact on terminal complexity and network performance.’
- ‘E-UTRAN is required to efficiently support inter-RAT measurements with acceptable impact on terminal complexity and network performance, by e.g. providing UE's with measurement opportunities through downlink and uplink scheduling.’
- ‘The interruption time during a handover of real-time services between E-UTRAN and UTRAN is less than 300 msec’
- ‘The interruption time during a handover of non real-time services between E-UTRAN and UTRAN should be less than 500 msec’

- e) 'The interruption time during a handover of real-time services between E-UTRAN and GERAN is less than 300 msec'
- f) 'The interruption time during a handover of non real-time services between E-UTRAN and GERAN should be less than 500 msec'

2.3. Evolved System Architecture

2.3.1 Architecture overview

The design goal of LTE architecture is a simplified and more efficient all-IP system, optimized for packet traffic. For example Radio Network Controller (RNC) used in early 3G releases for Radio Resource Management (RRM) functions, is removed and its intelligence is moved to the Evolved Node B (eNodeB). Another considerable difference to legacy cellular systems is that there is no circuit switched domain in LTE architecture. The core network is solely all-IP, and therefore control data and user data as well as voice are all transferred on top of packet switched IP-protocol. LTE terminal supporting multimode operation is however specified to be capable of Circuit Switched Fall Back (CS FB), which means that the terminal is transferred to UTRAN or GERAN circuit networks if there is no VoIP support in the LTE network. Later on when VoIP support is added, Single Radio Voice Call Continuity (SR-VCC) can be used for handing over existing VoIP calls to GSM and WCDMA circuit switched networks. Packet switched I-RAT handover is naturally also supported and can also be used as an intermediate step in handovers from LTE packet domain to 3G or 2G circuit switched domain. [1]

LTE network can be divided into two subsystems. Evolved UTRAN is the radio access network that manages the wireless access part providing an access point to the users. Evolved Packet Core (EPC) is then the core network part that manages user mobility and interconnects the radio access part to other networks and services. Network elements are connected to each other by specified interfaces that will also be explained briefly here. The architecture is based on open interfaces, which means that the interworking devices can be manufactured by different vendors to incite more competition.

The high level architecture of 3GPP LTE is illustrated below in Figure 2. A more detailed overview of LTE system architecture, network elements and the interworking principles between the elements via interfaces is specified in 3GPP document TS 23.401 'General Packet Radio Service (GPRS) enhancements for Evolved Universal Terrestrial Radio Access Network.' [17]

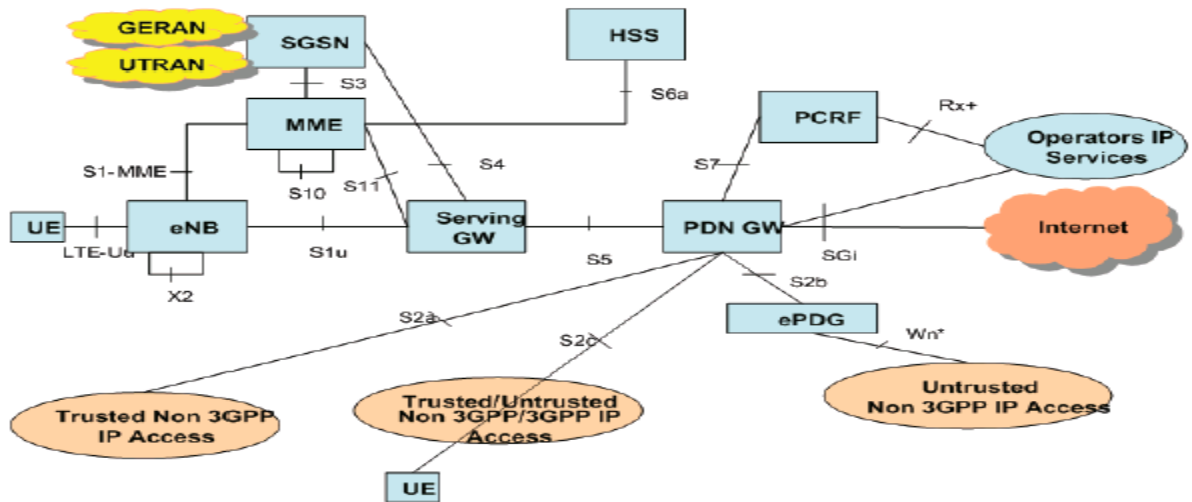

Figure 2: High level architecture of 3GPP LTE [18]

2.3.2 Evolved UTRAN

E-UTRAN is the radio access part of LTE network that terminates all radio related functions.

User Equipment (UE) is not necessarily considered a part of E-UTRAN but nevertheless it is the other end of the radio access part of the network. It is typically a mobile handheld terminal or module that provides a wireless radio connection to eNodeB over the Uu interface. UE also contains the Universal Subscriber Identity Module (USIM), which provides support for security related functions such as authentication, data integrity and encryption.

eNodeB is the wireless access point for UEs and the termination point of radio protocols. It handles all traffic between UE and EPC and performs Radio Resource Management (RRM) functions such as dynamic allocation of radio resources to UEs according to Quality of Service (QoS) requirements. The interface that connects neighbouring eNodeBs is X2, which provides functionalities for parameter exchange and mobility control between eNodeBs. The interfaces towards the EPC are S1-MME and S1u for control and user data flows respectively.

2.3.3 Evolved Packet Core

EPC is the fixed core part of the network that interconnects the radio network to other packet data networks. It also performs functions such as admission control, mobility management and contains user profile information.

Mobility Management Entity (MME) is the control part of EPC and the centre of the mobility architecture. It keeps track of UE location at eNodeB level in active connection mode and on Tracking Area (TA) level in idle mode. It sets and releases resources in S-GW via S11 and eNodeB via S1-MME in case of user activity mode changes and handovers, and also participates in handover signalling. MME interconnects to *Home Subscriber Server (HSS)* via

S6a interface to retrieve user subscription information and provide authentication and security mechanisms. MME is also a critical element in I-RAT handovers to legacy 3GPP systems as it interconnects with GERAN and UTRAN through *Serving Gateway Support Node (SGSN)* via the S3 interface. MME relays the Handover Command originating in the target Access System to the serving eNodeB, which then initiates the handover procedure. Two MMEs interconnect through the S10 interface.

Serving Gateway (S-GW) is mainly used for relaying user plane data between eNodeB and P-GW. It performs the mapping of IP service flows in the S5 interface to GTP-tunnels in S1 interface. Each service bearer is allocated a GTP-tunnel or alternatively all IP-flows towards a UE are allocated a single GRE-tunnel depending on the configuration. S-GW is the mobility anchor for inter-working with other 3GPP technologies. During mobility S-GW is responsible for remapping the GTP-tunnels towards UE as the serving eNodeB changes. S-GW may also be configured to perform traffic monitoring for accounting and charging purposes. S-GW interfaces with SGSN via S4.

Packet Data Network Gateway (P-GW) is the IP mobility anchor as it resides at the edge of the LTE network. It interconnects EPC with other data networks and is also connected to *Policy and Charging Resource Function (PCRF)* through the S7 interface. The most important interconnection from service point of view is towards the Internet. P-GW allocates IP-addresses to UEs that are used in SGi interface for IP-connectivity to Internet-services. As the edge router P-GW performs gating and filtering functions to and from the Internet. To provide uninterrupted service during mobility, the goal is that the UE IP-address is not changed at P-GW. UE mobility stays therefore hidden from service point of view so that only GTP-tunnels are modified for correct switching within the LTE network. P-GW is also the mobility anchor for non-3GPP inter-working. [1]

2.4 LTE Air interface concepts

LTE provides an impressive set of new air interface concepts. This chapter introduces OFDMA and SC-FDMA as downlink and uplink multiple access methods respectively. Multiple antenna techniques, such as MIMO, are also explained at the end of this chapter. Some of the most important LTE air interface techniques are illustrated in Figure 3 below. Some of these air interface techniques such as higher order modulation, fast link adaptation and HARQ, have been introduced also in the latest HSPA releases. These are however important functionalities also in LTE and will be explained in Chapter 2.5 related to protocols.

The air interface is likely to be the bottleneck link in the network. Therefore for the most part the user delay as well as handover delay is caused by the air interface. Handover failures and call drops are also likely to be caused by, e.g. radio link failures in the air interface.

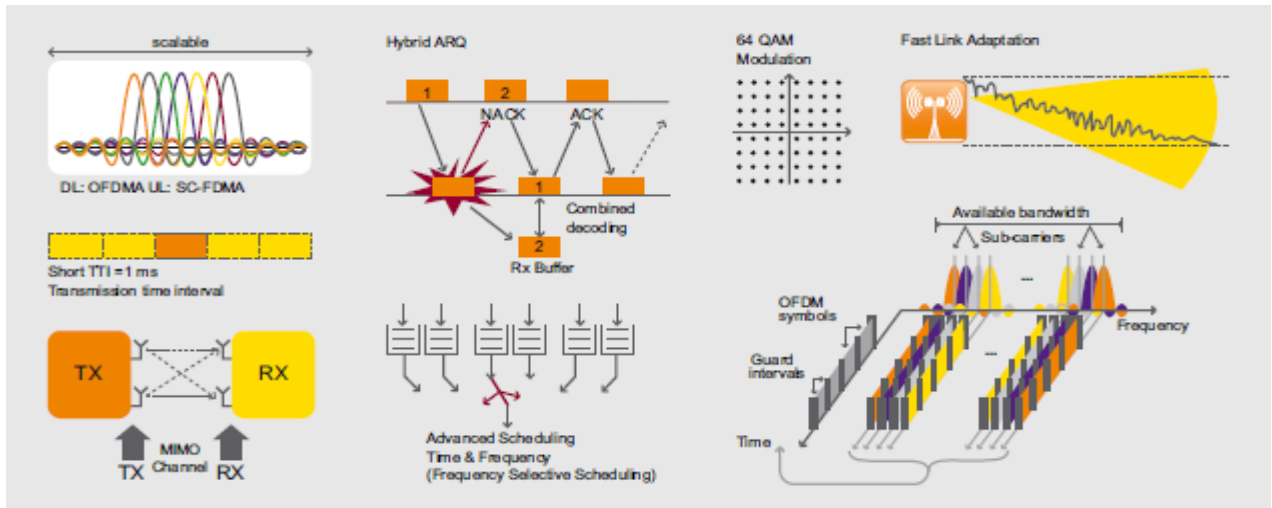

Figure 3: LTE Air interface techniques [19]

2.4.1 OFDMA as a downlink multiple access method

Orthogonal frequency-division multiplexing (OFDM) is a digital modulation method used in several wireless radio access and broadcast systems such as WiMAX, WLAN and DVB, as well as ADSL wireline systems. It provides good spectral properties and performance in frequency fading channels. OFDM is based on closely-spaced narrowband subcarriers that are mutually orthogonal. The creation of OFDM signal in transmitter receiver chain is illustrated in Figure 4.

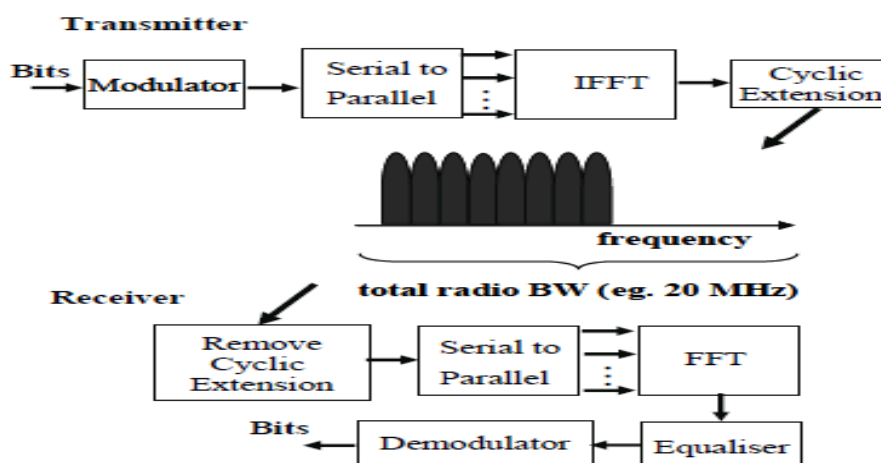

Figure 4: OFDMA transmitter and receiver [1]

The orthogonal subcarriers are created with an IFFT transformation of signal from frequency domain to time domain. Subcarriers are set to be 15 kHz apart in LTE. Then a cyclic extension is added to the signal, which is then transmitted over the air interface. The receiver

then performs the cyclic extension removal and FFT operations in the opposite direction to extract the sent bits correctly. [20]

OFDMA is then a multiple access method that allocates OFDM channels to multiple users and separates the users in frequency and time. The minimum allocation for one user in LTE is one resource block, which corresponds to 12 subcarriers in frequency and one Transmit Time Interval (TTI), which equals 1ms in time. Ideally there should be no Inter Carrier Interference (ICI) between users due to orthogonal carriers. In practise frequency synchronization is required due to receiver imperfections and frequency offset of moving UEs caused by the Doppler shift. Inter Symbol Interference (ISI) in time domain caused by delayed multipath versions of transmitted signals, is then mitigated by adding a guard interval, a cyclic extension, to the symbols. RAKE sub-receivers used in 3G systems for combining multipath components are therefore not needed in LTE. Traditional methods such as interleaving for burst error prevention and coding to provide Forward Error Correction (FEC) are also utilized to improve reliability of the radio transmission. Interference from other cells remains a major issue since same subcarriers are used in neighbouring cells as LTE is a reuse 1 system. Various methods for Inter Cell Interference Coordination (ICIC) have been proposed to mitigate the interference, e.g. cell edge frequency reuse. [20]

Power control can be utilized in downlink control channels but for data channels, power control is not utilized in LTE downlink. Instead a method called Adaptive Modulation and Coding (AMC) is used that adapts the modulation scheme and coding rate according to varying radio conditions. UE measures the channel quality and gives feedback to the eNodeB in Channel Quality Indicator (CQI) reports and according to the CQI, the eNodeB chooses the optimal Modulation and Coding Scheme (MCS). The goal is to achieve a target Block Error Ratio (BLER) that maximizes the throughput in the given radio conditions according to Carrier to Interference plus Noise Ratio (CINR). Modulation types QPSK, 16QAM and 64QAM as well as a wide set of coding rates are supported in LTE downlink. The modulation scheme defines how many bits can be carried per symbol. The coding rate then defines the ratio of redundant bits per user bits. Therefore the chosen MCS value defines an absolute value for the user throughput in given radio conditions. In a mobility case this means that as the user traverses towards the edge of neighbouring cells that interfere with each other, his or her throughput decreases in a stepwise manner. Then as the handover occurs, the throughput goes to zero for the duration of the handover break. In the new cell the user throughput then

starts to increase as he or she continues to move away from the cell edge and towards the cell centre and better radio conditions. [20]

2.4.2 SC-FDMA as an uplink multiple access method

Uplink transmission uses SC-FDMA as multiple access method. The difference to OFDMA is that the data symbols in SC-FDMA occupy a frequency range of $M \cdot 15\text{kHz}$ adjacent subcarriers with M times the rate, hence the name Single Carrier. OFDMA symbols then consist of only one subcarrier that is transmitted at constant power during the entire symbol period of $66.7\mu\text{s}$.

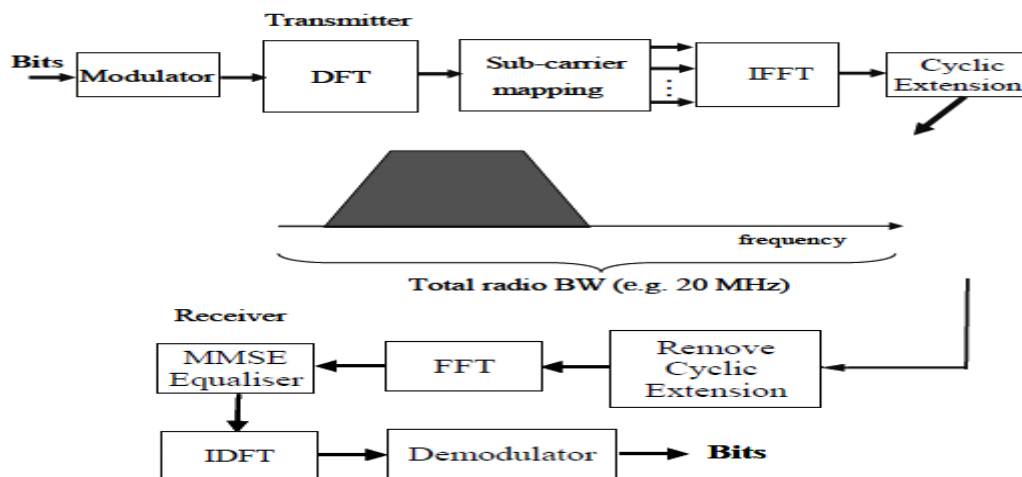

Figure 5: SC-FDMA transmitter and receiver [1]

The transmitter receiver chain is similar to that of OFDMA. The difference is that after modulation, the symbols are converted to frequency domain and mapped to the desired bandwidth. After that an IFFT is performed as in OFDMA to convert the signal back to time domain for radio transmission.

LTE uplink utilizes only slow power control since there is no near-far problem like in WCDMA due to orthogonal resources. The point is to reduce terminal power consumption and avoid a large dynamic receiver range in eNodeB side rather than interference mitigation. Power control for LTE is standardized in [21]. Uplink supports modulation types up to 64QAM but the terminal side may be limited to only 16QAM. LTE release 8 does not support multiple antenna transmission in uplink and therefore data rates are significantly lower compared to downlink transmission. [1]

More extensive descriptions for LTE multiple access methods including detailed mathematical principles can be found in references [22] for OFDMA and [23] for SC-FDMA.

Multiple access methods as well as MIMO techniques discussed next are some of the key LTE air interface concepts. These concepts however have little relevance to I-RAT handovers.

2.4.3 Multiple antenna techniques

The basic antenna configuration is *Single Input Single Output (SISO)*, which means that one antenna is used to transmit data and one antenna receives the data. The fundamental idea to adding multiple antennas is that it improves performance because the radiated signals take different propagation paths. LTE release 8 supports multiple antenna modes of up to 4 transmit and 4 receive antennas. Multiple antenna methods used in LTE including SISO, SIMO, MISO and MIMO are illustrated below in Figure 6.

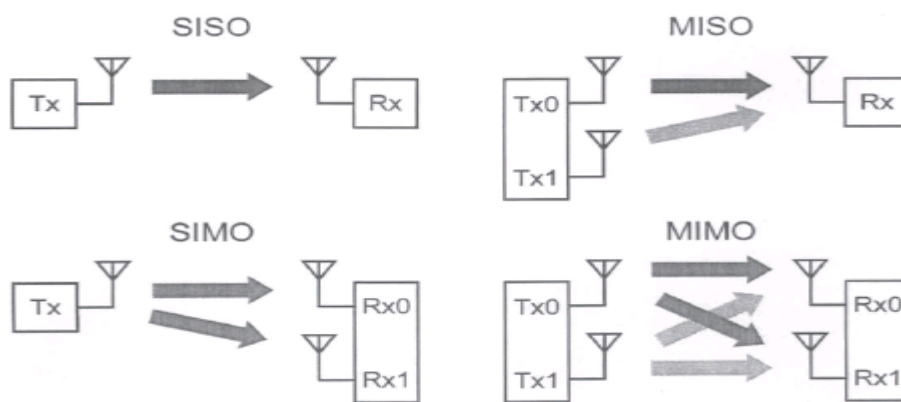

Figure 6: Multiple antenna techniques [20]

Multiple Input Single Output (MISO) and *Single Input Multiple Output (SIMO)* are transmit- and receive diversity techniques. They provide path diversity in poor radio conditions since fading loss can be much higher for the other signal path. The receiver can thus select the signal with a better CINR. Data rates are however not increased in diversity techniques since the same data is transmitted in both signal paths.

Multiple Input Multiple Output (MIMO) differs from transmit diversity techniques in such a way that different data streams are sent in different signal paths. Theoretically in case of orthogonal data streams, the downlink user data rate can be doubled in case of *2x2 Single-User MIMO*. The data streams are separated by using a channel matrix that aims to provide orthogonal signals at the receiver. Stream pairing feedback can be used in case of Closed Loop MIMO operation. This operation is similar to channel quality feedback CQI reporting but a different metric, namely Precoding Matrix Indicator (PMI) is used for transmitter precoding matrix optimization. Precoding is done to minimize the coupling of the spatial streams.

Release 8 defines also *Multi-User MIMO*, which can be used in uplink direction so that the same time-frequency resources are utilized by two UEs. The data rate for the UEs is not increased but more capacity is added on a cell level. MIMO works in general well only in good radio conditions and therefore link adaptation is used to switch the transmission mode to transmit diversity in poor radio conditions, i.e. at the cell edge. Handovers within intra-frequency LTE cells always occur in transmit diversity mode since the cells are interfering with each other and thus the radio conditions are expected to be poor at the cell edge. [20]

2.5 LTE protocol structure and main tasks

This chapter gives an overview of the protocols that are used in LTE network for control and data transport purposes. The main focus here is on radio related protocols, specified in 3GPP document TR 25.813 [24]. As mentioned, the network layer protocol in the EPC is Internet Protocol (IP). Basically a number L1 and L2, e.g. Ethernet and ATM, can be used to transport IP in the core network. These networking technologies or the detailed functionalities of the IP-protocol for that matter are outside the scope of this document and will not be discussed further here.

The protocol stacks in LTE network for user plane and control plane are illustrated in Figures 7 and 8 respectively.

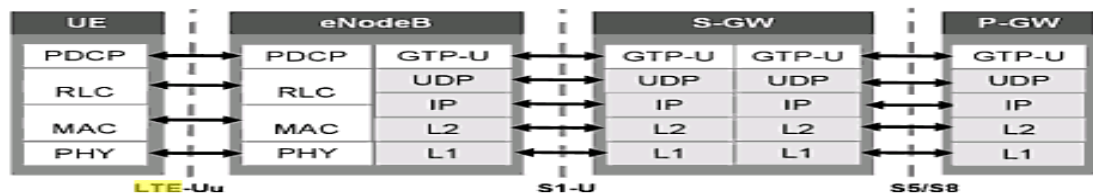

Figure 7: User plane protocol stack in EPS [1]

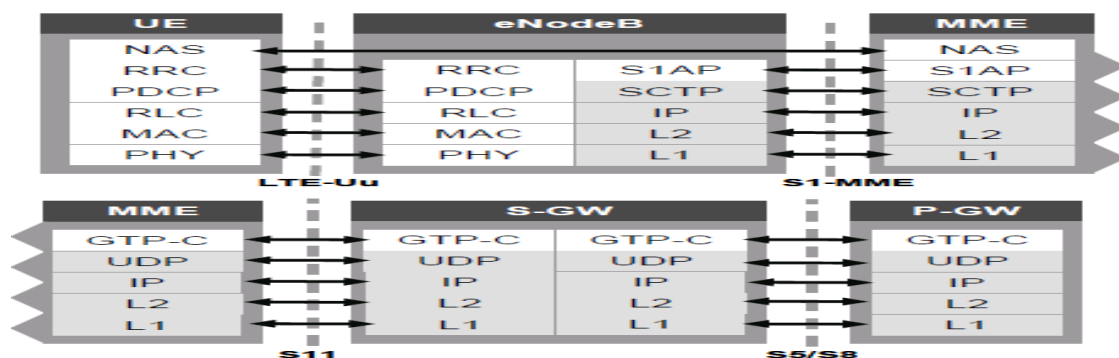

Figure 8: Control plane protocol stack in EPS [1]

2.5.1 Physical layer

Physical layer provides the means for transmission of data, originating in the higher layers, on the Uu interface between the UE and the eNodeB. Resource usage in LTE is such that

there are only shared resources that are allocated dynamically. Dedicated channels can exist on logical level but they are transported on the same shared channel. The data is transferred on shared physical uplink and downlink channels that use SC-FDMA and OFDMA for multiple-access methods respectively. Different modulation schemes can be used for different channels and typically a lower modulation scheme is used in control channels to improve the reliability of critical control data. Physical layer also performs tasks such as antenna mapping, channel coding, interleaving, rate matching and CRC checking to ensure correct reception of data. Physical layer channels need to support higher layer functions such as Link Adaptation and HARQ.

Physical layer provides physical channels for data transfer services to MAC and higher layers. Physical channels are then mapped to transport channels as illustrated in Figure 9 below. Physical layer only provides the means for data transfer and can only be characterized by how data is transferred over the air interface. Transport channels are then mapped into logical channels on the RLC-layer that specify what type of information is transferred. Physical Downlink Control Channel (PDCCH) and Physical Uplink Control Channel (PUCCH), used for control signaling such as channels feedback and HARQ, are not mapped to any transport channels. The tasks performed by transport channels are summarized below. [9]

- *Broadcast Channel (BCH)* is used in downlink to broadcast the necessary parameters the UEs need to access the system such as random access parameters. The UEs listen to the broadcast channel to receive System Information Block (SIB) messages that are sent periodically. Inter-frequency and inter-RAT idle state mobility is based on the neighboring cell measurement- and reselection offset parameters that the UE receives within these messages.
- *Downlink Shared Channel (DL-SCH)* and *Uplink Shared Channel (UL-SCH)* are used for point-to-point control- and user data transfer.
- *Paging channel (PCH)* is used for paging procedure in downlink to initiate a RRC connection.
- *Multicast Channel (MCH)* can be used to for point-to-multipoint multicast services. MCH is however not included in LTE release 8.
- *Random Access Channel (RACH)* is similar to PCH in uplink as it is used to initiate connection to the eNodeB through the random access procedure. Random access procedure is needed also to initiate a connection to the target cell in handovers.

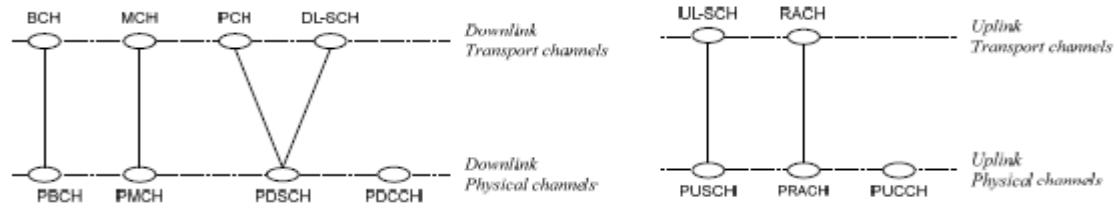

Figure 9: Mapping of Transport channels to physical channels [9]

Physical layer also provides channel quality measurement that can be used as feedback to the system. The most important measurement value in LTE related to handovers is Reference Signal Received Power (RSRP). That is calculated as an average from the measured reference signals and is also used for handover decisions. Channel quality and signal strength need to be measured for correct link adaptation, power control and timing advance calculation. Measurements for signal strength need to be performed also for neighboring cells that may operate at a different frequency, so that handovers would be possible. Handover related measurements will be discussed in detail in Chapter 3. A general description of LTE Physical layer is given in 3GPP document TS 36.201 [25] and a more detailed description of physical layer aspects and measurements can be found in TR 25.814 [26].

2.5.2 Medium Access Control

MAC-sublayer is specified in 3GPP standard TS 36.321 [27]. MAC layer performs multiplexing/demultiplexing and priority handling of RLC Payload Data Units (PDU) and passes the data down to physical layer for transmission. The mapping between transport channels and logical channels is done at MAC layer. Transport channels, that were already discussed previously, are then mapped to physical channels in physical layer as already mentioned. MAC layer includes several important control functionalities such as dynamic scheduling and HARQ to name a few.

Dynamic Scheduling

The idea behind dynamic scheduling is to allocate radio resources to users in an efficient manner to fully utilize the scarce radio spectrum that is available. Usually a proportionally fair scheduling algorithm is utilized in the eNodeB so that users with instantaneously relatively best channel conditions are assigned the radio resources. However other scheduling algorithms can be configured as well. Round Robin is a scheduling algorithm that assigns the resources to users in a cyclical manner. Max C/I algorithm then assigns the channel to the user with the best channel quality, which can lead to high system throughput but low throughput at the cell edge.

HSPA introduced fast scheduling only in time domain. Frequency domain scheduling is not possible in HSPA because of the wideband nature of the signal due to CDMA multiple access method. LTE however introduces scheduling in both time and frequency domain resource blocks per 1ms TTI as illustrated in Figure 10. As fading occurs in both time and frequency domain, fast scheduling in both domains brings a significant increase in cell throughput. According to simulations up to 40% increase can be achieved in cell throughput with low UE speeds with frequency domain scheduling. Scheduling decisions can have a significant impact on the user data delay as well as handover service interruption time. [1]

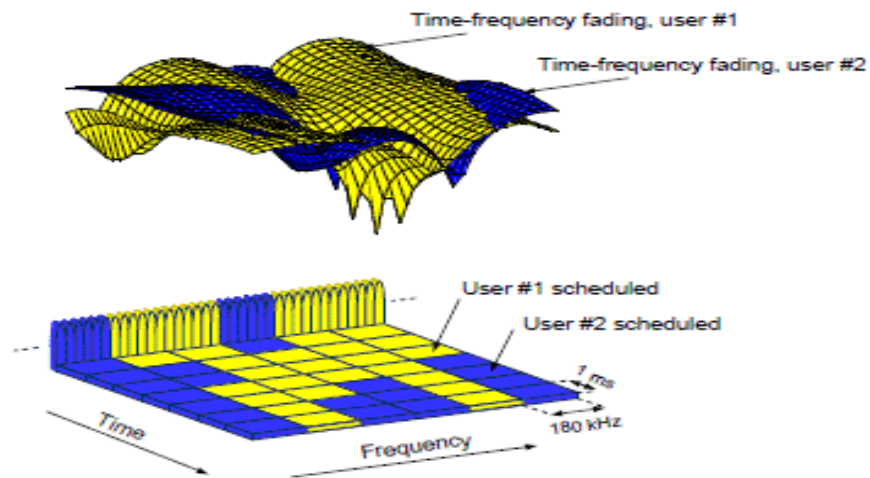

Figure 10: Channel-dependent scheduling in time *and* frequency domains [13]

HARQ

Hybrid Automatic Repeat Request (HARQ) is based on the use of traditional stop-and-wait ARQ protocol. Each received packet is performed a CRC check to ensure correct reception. An Acknowledgement (ACK) or a Negative Acknowledgement (NACK) is sent back depending on whether the packet is successfully decoded or not, and in case of NACK, a retransmission will take place. HARQ operation then supports multiple simultaneous ARQ processes to improve channel throughput. Retransmission can use soft combining which means the same data is sent in retransmission, or incremental redundancy which means that additional redundancy is used in retransmissions to increase the probability of correct reception. The received packets are combined for additional coding and decoding decisions are done for the combined packets.

2.5.3 Radio Link Control

RLC-sublayer is specified in 3GPP document TS 36.322 [28]. Data is passed to RLC-layer from the higher layers. Data segmentation is then performed and the data is passed to MAC-layer in logical channels. RLC-layer adds an additional ARQ error correction mechanism to

correct errors coming from the lower layers. Three different modes of operation have been defined for RLC that can be used according to the service layer bearers requested by the user.

- Transparent Mode (TM) passes data in logical channels without adding any headers to it. Therefore it can be used for data that does not need physical layer retransmissions
- Unacknowledged Mode (UM) provides functionality for in-sequence delivery of data by adding headers with sequence numbers, so that data sent in lower layer HARQ operation can be received correctly
- Acknowledged mode (AM) adds an ARQ retransmission functionality to UM for data lost in the lower layers

2.5.4 Packet Data Convergence Protocol

PDCP, specified in 3GPP TS 36.323 [29], is located at the top of the user plane radio protocol stack. All user data as well as control data pass through PDCP layer on the radio interface. Security related functions such as ciphering and deciphering, and integrity protection and verification are performed in this layer.

PDCP-layer receives data in downlink and sends in uplink to GTP-layer. There are two kinds of data in PDCP-layer. Data packets are passed down to RLC-layer in Data Radio Bearers (DRB) and control packets in Control Radio Bearers (CRB). There is no need to send the entire TCP/IP protocol stack on the radio interface since the Radio Bearers (RB) are mapped to GTP-tunnels on top of IP-protocol. Therefore Robust Header Compression (RoHC) is used to compress the IP-header from up to 40 bytes down to 3 bytes, thus reducing the overhead. Radio interface protocols in layer 2 and their main tasks are summarized in Figure 11. [30]

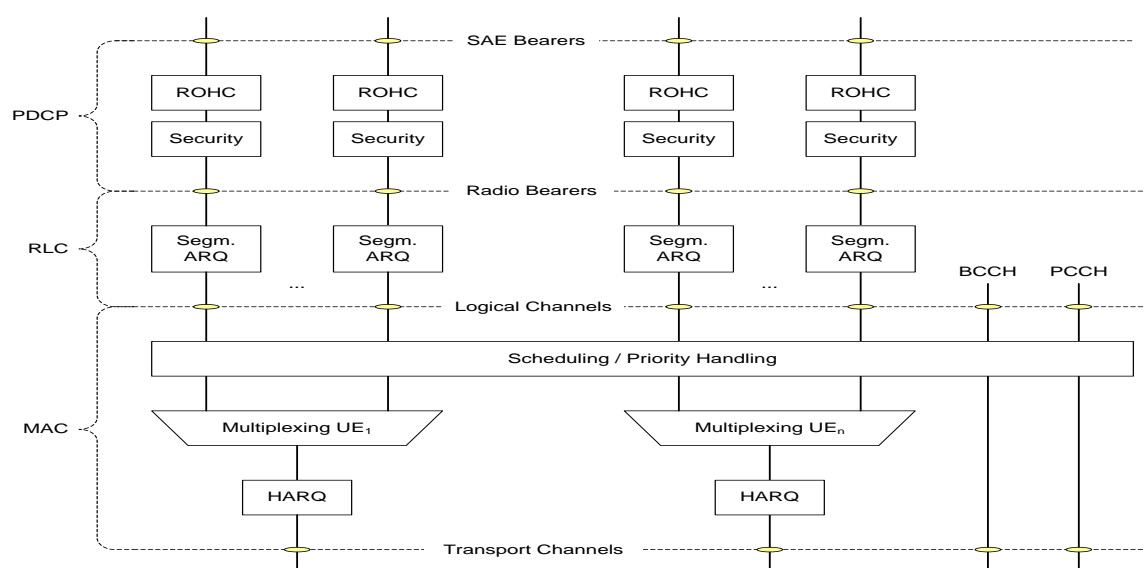

Figure 11: Radio interface protocols [24]

2.5.5 Radio Resource Control

RRC-layer specified in TS 36.331 [31], handles most of the control information exchange between UE and E-UTRAN. Establishment, management and release of Radio Bearers are handled by RRC. Radio Bearers are then mapped to EPS bearers that define what type of service quality and packet priority handling is provided to the user. EPS bearers define the QoS profile in terms of delay budget, loss rate and differentiation of guaranteed or non-guaranteed bit rate.

System information is broadcasted in RRC messages and parameter exchange between UE and eNodeB is handled by RRC. The LTE UEs can be in one of the two states, *RRC_IDLE* or *RRC_CONNECTED*, that are defined as follows:

UEs in *RRC_IDLE state* listen to the broadcast channel to get the system information and paging channel for mobile terminated calls. Also neighbouring cell measurements are performed. In idle mode mobility is UE controlled and based on cell reselections rather than handovers.

UEs in *RRC_CONNECTED state* are sending or receiving data from the eNodeB. They use shared channels for data transfer and provision of channel quality and feedback. Mobility in this state is based on handovers controlled by the serving eNodeB.

RRC-layer is responsible for radio connection establishment, handover related measurements and handover management. These functions will be explained in detail in Chapter 3.

2.5.6 Core network protocols

This chapter explains in brief the protocols that are used in LTE core network. There are several different protocols for both control- and user plane data and basically these are completely different than those of the Uu interface. This is mostly because of the different purposes of various core network elements and a more reliable transmission medium. Different protocols are used for control signalling between various network elements as well as for reliable user plane data transfer. The common nominator for core network protocols is that they are all transferred on top of IP-protocol, which can be transported by a number of L1 and L2 technologies, such as Ethernet.

IP-packets are transferred in the EPC in GTP-tunnels as explained in Chapter 2.3. An exception to this is the interface between MME and eNodeB that utilizes S1AP for control signalling, and is transported on top of Stream Control Transmission Protocol (SCTP). Two eNodeBs then communicate with X2AP-protocol for control signalling such as intra LTE

mobility management, inter-cell interference coordination and load management. An important protocol regarding handovers is Non-Access Stratum (NAS), which is used for signalling between UE and MME. NAS-protocol includes functions for attaching/detaching from the network, mobility management on the network level and E-UTRAN bearer management. [1]

EPS bearers provide quality of service all the way between the UE and P-GW within the LTE network. External bearers can then be utilized between P-GW and a peer entity residing in the Internet. Combining these bearers with a transport layer protocol such as TCP or UDP we have an end-to-end connection between the user and the corresponding node that satisfies the quality of service requirements for a given service. Finally on top of the protocol stack we have the application layer that provides the actual end-to-end service, such as video streaming, and sets the specific requirements for the lower layers. In the next chapter it will be discussed how this end-to-end service quality can be maintained as the user traverses the mobile network and how the protocols introduced in this chapter relate to user mobility.

3. MOBILITY

There are several clear advantages to user mobility. Nomadic users can get connected anywhere within their operators radio access network. Moving users can stay connected by handovers to the cells closer by to the users as they move in the network all the while maintaining their services. International roaming even provides the ability to communicate through visiting foreign operators' networks. Seamless mobility and anywhere anytime type of service provision, have always been key design principles for legacy cellular networks and LTE is no exception here. However as discussed in Chapter 1, I-RAT mobility is a critical feature for providing this seamless service.

This chapter introduces the mobility scenarios, and the underlying mechanisms introduced in LTE. The concepts studied in Chapter 2 are also related to mobility aspects here to tie together the literature study part before going in to the practical handover testing work, which is discussed starting from Chapter 4. The contents of Chapter 3 are as follows. Chapter 3.1 introduces the background, motivations and basic principles for user mobility. Chapter 3.2 discusses handovers within the LTE network as context to the actual research discussion of Inter Radio Access Technology handovers that are studied further in Chapter 3.3.

3.1 Introduction to mobility

3.1.1 Requirements for user mobility

As mentioned in the introductory chapter, LTE is expected to be available only in hot spots in the beginning. Therefore it is clear that mobility across Radio Access Technologies is critical to provide the same level of seamless mobility service users can already get with 3G devices. Services set stringent requirements for seamless mobility. First of all, non real-time data should not be lost during the service break in the handover procedure. Service break then should be minimized as well as failures and drops during the handover procedure. Tearing down and setting up new connections instead of seamless handovers may cause significant degradation of user experience. Applications may have to re-authenticate to services and streaming services may have to be restarted. IP-address seen by the services is not supposed to change in the middle of a data session. Therefore mobile-IP is utilized and PDN-GW is used as the IP-mobility anchor in LTE, as already explained briefly in Chapter 2.3.3. Naturally the UE needs to be authenticated to the target cell in all mobility cases. This means that the USIM needs to be known at the MME serving the target cell. In practise this means

that, handovers to cells belonging to other operators have to be allowed in the subscriber profile. [5]

Seamless mobility features and the functionalities described above need to be supported in the LTE core network. In case of I-RAT mobility, it is also required that the target radio access network is capable of handling the incoming user seamlessly and the networks interconnect seamlessly. From the UE part, it is required that the UE is able to handle both source RAT and target RAT modes of operation and supports seamless transition between the technologies. LTE cells as well as inter-technology cells may operate at a different carrier frequency. Therefore the UE needs to be capable of operating on different frequency bands and perform measurements on other frequencies. Dual transmit devices can communicate and perform measurements on two frequencies or technologies simultaneously. Most of the current UEs are however single transmit devices. These devices can listen to only one frequency at the time and therefore measurement gaps need to be scheduled for the UE to perform inter-frequency measurements.

Inter-Technology handovers, that is handovers to non-3GPP technologies, generally may not support seamless mobility from LTE. This means that the connection to an LTE network needs to be terminated before a new connection towards the target technology can be established. However for Inter Radio Access Technology handovers, that is handovers towards 3GPP technologies, are designed to be ‘make before break’ seamless. In this case the network resources are reserved in advance in the target RAT prior to the handover procedure. That is, as long as the implementation supports this feature. Solutions for seamless Inter-Technology handovers towards non-3GPP systems are discussed more in [4].

3.1.2 Mobility scenarios

When an LTE UE is powered on, it scans all E-UTRA Radio Frequency (RF) bands and starts to listen to the broadcast channels for synchronization. This is done to find a suitable cell for initial camping with the best radio conditions according to cell RSRP measurements. After cell selection, the UE registers to the network and starts to measure intra-frequency neighbours as candidates for cell reselection according to cell ranking criteria. Usually this means that reselection is performed if the radio conditions, according to RSRP measurements, are better than a configured threshold above that of the serving cell. The threshold needs to be high enough to prevent a ping-pong effect of fading users going back and forth between cells. However too high a threshold may result in drops at the cell edge as the radio conditions get

too bad for transmission. The UE also measures the inter-frequency cells according to the neighbouring cell list received in the broadcast channel. This list contains also the inter-system neighbouring cells and their frequency carriers as well as the parameters used in the UE measurements.

Measurements for neighbouring cells are not necessarily performed at all in case the RSRP that the UE measures from the serving cell is high enough. In fact the parameters for starting intra-frequency, inter-frequency or inter-system measurements can be configured separately at the eNodeB. Alternatively the procedures for inter-frequency or inter-system measurements can be disabled so that the UE does not even perform these measurements. [32]

The thresholds for actually triggering a cell-reselection procedure are as well configurable separately and can be prioritized accordingly. Prioritization is especially useful for forcing the UEs to camp in a certain radio access technology cell or a certain frequency cell. This way an LTE cell that has better service capabilities can be prioritized over e.g. a WCDMA cell. Parameters as such, should be configured based on the layout and dimensioning of the radio network and also optimized accordingly to obtain the best possible performance. It should be noted that there are no right or wrong values for the set of parameters for every given cellular radio network. Parameter optimization in a given network is by no means a trivial task. Network dimensioning and parameter optimization as well as fault coordination is however expected to become automated and self correcting with the implementation of Self Organizing Networks (SON). The details of SON are discussed further in [33].

Finally, neighbouring cells can be configured as blacklisted so that UE measurements are not performed to those cells. The blacklists can be configured in the eNodeB for neighbouring cells and provided to the UEs by the serving cell in system information messages. They can be useful to avoid users from performing unnecessary and time consuming measurements on other frequencies. Blacklists can also be used in network planning to prevent unwanted handovers between certain cells or handovers towards certain directions. The use cases for this feature are numerous. For example micro cells can be isolated from macro cells. In general certain geographical areas such as rivers, country borders etc. can be separated. With blacklists, neighbouring cell configuration can still be used for X2 connectivity to, e.g. perform handovers in one direction and perform inter-cell interference coordination. For connected mode mobility, a whole set of parameters for measurements and handover thresholds can be configured in a similar fashion as discussed here for idle mode mobility. These will be discussed further in Chapter 5. [34]

There are various scenarios for user mobility in the cellular radio access network. Mobility can be isolated within one radio access technology, i.e. Intra-LTE mobility. In addition mobility can be configured to extend to Inter Radio Access Technology within 3GPP, or Inter-Technology handovers outside the 3GPP set of technologies, for example WLAN, WiMaX or 3GPP2 family of technologies. User mobility case in an example cellular network is given in appendix A.

Mobility scenarios within 3GPP can be characterized also by the UE state and the required user service as illustrated in Table 2. In addition to the mobility scenarios presented in Table 2, 3GPP defines an additional inter-operability mechanism called Network Assisted Cell Change (NACC) for handing over packet data sessions. This feature is however defined only for mobility between E-UTRAN to GERAN when PS handover is not supported. The scope of this thesis is however focused in packet switched handovers. The details for other mobility scenarios can be found in [1].

Table 2: User mobility scenarios

Mobility scenario:	Related function:	Description:
Idle state mobility	Cell reselection to Intra-LTE or Inter-RAT cell	The serving cell is changed according to user mobility to the best measured cell in idle mode
Circuit Switched Fallback	Cell reselection or intermediate PS handover to UTRAN/GERAN RAN	This service can be used for voice calls by using legacy cellular systems in case VoIP is not supported in the LTE network
Single Radio Voice Call Continuity	Handover to UTRAN/GERAN CS voice network	When VoIP is supported, this feature enables existing VoIP calls to be handed over to legacy CS networks
Packet switched handover	Handover to Intra-LTE cell or Inter-RAT PS network	Users in RRC connected mode can be seamlessly handed over to neighbouring cells

3.1.3 Handover basics

The amount of handovers in mobile networks is expected to increase with the growing trend of always on type of applications such as Skype, MSN Messenger or Facebook in smart phones. These applications send periodical keep-alive messages to the UE to poll the user availability. Therefore data is sent in active mode even if the applications are not in active use.

The delay requirements for different types of applications and services are discussed further in [35].

In LTE, handovers are always performed when an RRC connection exists, while in UTRAN network, connection can exist in CELL_PCH state that allows cell reselections. Therefore handover performance is an important issue in LTE. Handovers between E-UTRAN and UTRAN are however always performed from RRC CONNECTED state in E-UTRAN to CELL_DCH state in UTRAN. Handovers, as well as other state transitions within 3GPP inter radio access technologies are illustrated below in Figure 12.

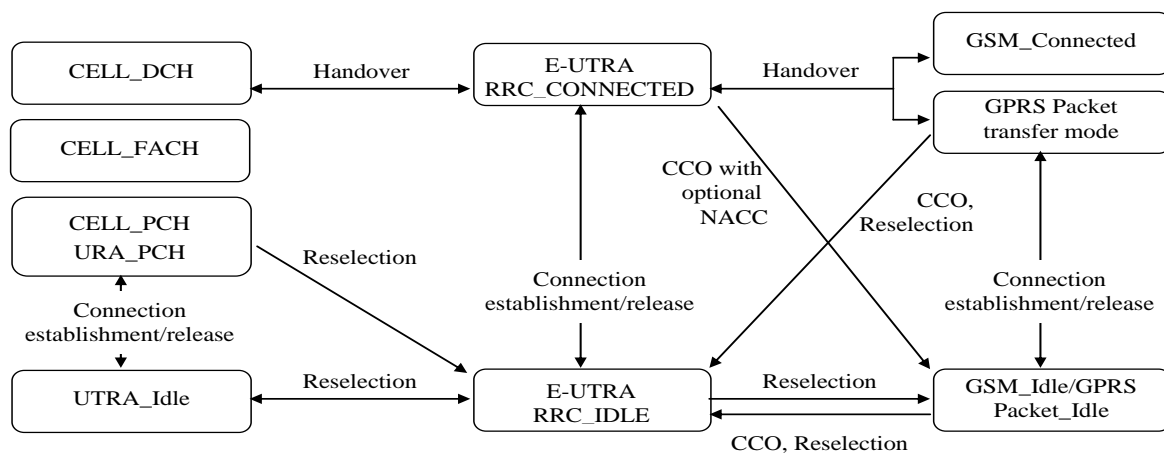

Figure 12: E-UTRA states and inter-RAT mobility procedures [17]

Handovers in E-UTRAN are network controlled and usually triggered by measurement reports sent by the UEs. When the UE initiates an RRC connection, it receives a list of measured cells in an RRC reconfiguration message. This message contains both intra-LTE and inter-RAT measured cell list and all the handover related parameters such as the thresholds and cell prioritization for measurement reports. In fact this is a very similar neighbouring cell RSRP measurement configuration that is sent also in the broadcast channel for idle state measurements discussed previously. However it is necessary to configure a different set of parameters for connected mode handovers. Cell prioritization and blacklisting can also be used in a similar fashion as in cell-reselections. Load control and service based handovers can also be performed in case of inter-frequency or inter-RAT handovers. They are however not possible in intra-frequency handovers.

The measurement reports are sent according to configured reporting criteria. Event triggered measurements are listed below in Table 3. Triggering criteria from A1 to A5 are based on E-UTRA measurements. For inter-RAT measurements, criteria B1 and B2 can be used. Upon receiving an event triggered report, the eNodeB can send a handover command to the UE to initiate handover preparation.

Table 3: Event triggered reports for E-UTRA and inter-RAT measurements [1]

Event triggered report	Criteria for triggering
Event A1	Serving cell becomes better than an absolute threshold
Event A2	Serving cell becomes worse than an absolute threshold
Event A3	Neighbouring cell becomes an amount of offset better than serving cell
Event A4	Neighbouring cell becomes better than an absolute threshold
Event A5	Serving cell becomes worse than an absolute threshold 1 and neighbouring cell becomes better than an another absolute threshold 2
Event B1	Neighbouring cell becomes better than absolute threshold
Event B2	Serving cell becomes worse than an absolute threshold 1 and neighbouring cell becomes better than another absolute threshold 2

3.2 Intra LTE handovers

3.2.1 Handover characteristics in LTE

Handovers within an LTE network are always hard, which means that a radio connection can exist to only one eNodeB at a time. The signalling connection and user plane GTP-tunnel are however established to the target cell prior to switching the radio connection. UTRAN in turn supports also soft and softer handovers, which means that a radio connection can exist simultaneously to several NodeBs or cells within one NodeB. Thus handover can be executed simply by switching the connection of the serving NodeB and terminating the initial connection. Handovers from LTE towards UTRAN are always hard but after the handover a soft handover procedure can be started as usual.

From the core network perspective, handovers are either X2 based in case neighbouring cell configuration is defined between the cells, or S1 based in case an X2 connection does not exist. X2 based handover is usually a more simple operation. MME relocation is not defined in this handover type but S-GW relocation may be executed. S1 based handover is always used in case there is no X2 connection between the eNodeBs. In this handover type, MME relocation as well as S-GW relocation may take place in case the target eNodeB is served by different core elements than the source eNodeB. S1 handover procedure is similar to inter-

RAT handover and thus will be discussed further in the next chapter. The rest of Chapter 3.2 covers merely X2 based handovers.

Since all the RRC functions reside within the eNodeB, both control plane and user plane context needs to be relocated in case of an inter-eNB handover. GTP-tunnelling needs to be changed and MME needs to update the UE location. Incoming data packets are buffered in the serving eNodeB during the handover break and forwarded to the target eNodeB on the X2 interface. This is called direct tunnelling as the X2 interface is present. In case of handovers between intra-eNodeB cells, the procedure is simpler, as the context relocation functions are not required. RRC functions within UTRAN networks reside mostly within RNC. Therefore control plane needs to be relocated only in a rare case of serving RNC change upon intra-UTRAN handovers. MME and S-GW relocation may be possible in intra-LTE handovers in case the target eNB is served by different core elements. [17]

3.2.2 Handover measurements

This chapter discusses handover measurements and handover triggering in intra-frequency handovers within the LTE network. Inter-frequency measurements and handovers are supported within LTE networks but these will be discussed further later on along with inter-RAT handovers.

The neighbouring cell RSRP measurement procedure is started when the serving cell signal quality drops below a configured threshold. The measurements are performed periodically from the neighbouring cell reference signals. The reference signal slots are spread around in the time-frequency resource slots of the whole system bandwidth so that measurements can be performed on a sub-band level as well as averages for wideband measurements. RSRP value is calculated as an average from the individual reference signals throughout the entire system bandwidth. The reference signals are cell specific and thus can be differentiated between cells using complex cyclic shift calculations so that the measurements from other cells can be differentiated. [1]

At the time of writing, the used event triggered reports in intra-LTE handovers are A3 for “better cell HO” and A5 for “coverage HO”. Out of these two, A3 is more common and basically a given cellular LTE network can provide decent mobility with merely A3 handovers. The A3 handover triggering procedure is illustrated in Figure 13 and explained below.

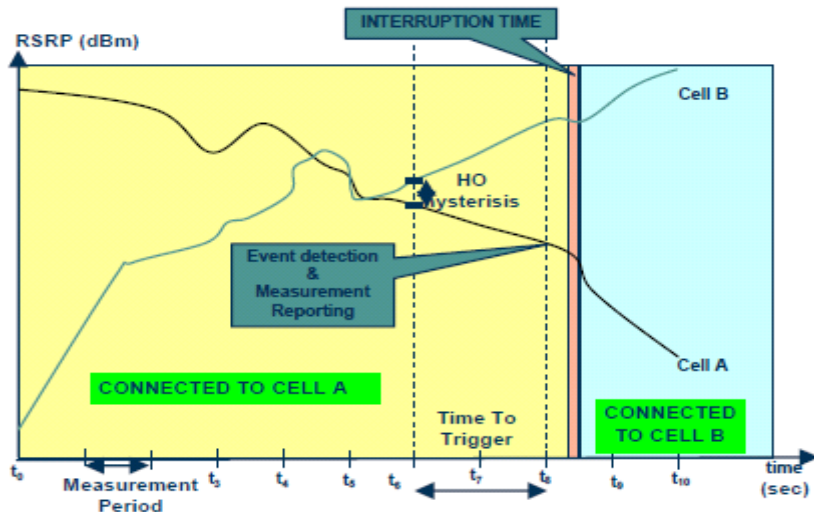

Figure 13: Handover triggering procedure [6]

The starting point of the handover triggering procedure is the measurements performed by the UE. These are done periodically as defined by the measurement period parameter configured at the eNodeB. When a condition is reached in which the serving cell RSRP drops an amount of the configured HO offset, usually 2-3dB, below the measured neighbor cell, a timer is started. In case this condition lasts the amount of the Time To Trigger (TTT) value, a measurement report is sent to the eNodeB, which initiates the handover by sending a handover command to the UE. In case the reporting conditions change and no longer satisfy the triggering conditions before the timer reaches the TTT value, a measurement report will not be sent and new measurement calculations and timers are started.

The handover parameters need to be optimized for good performance. Too low handover offset and TTT values in fading conditions result in back and forth ping-pong handovers between the cells. Too high values then can be the cause of call drops during handovers as the radio conditions get too bad for transmission in the serving cell. It should be noted however that the user data interruption time is not affected by these parameters since the handover, and thus the interruption time, is initiated only after the UE receives a handover command. Prior to receiving the command, the UE sends and receives data as usual. For example handover command may have to be retransmitted several times by the HARQ process but if the call is eventually successfully handed over, the user service delay remains unaffected. Throughput on the other hand may drop below the QoS target in poor radio condition as a low MCS needs to be utilized. The goal is that the handover command is received before the signal-to-interference ratio or RSRP gets too low to avoid call drops. [6]

3.2.3 Handover procedure

The handover procedure in LTE is done in distinctive steps. According to Holma and Toskala, [1] there are three steps in an X2 handover process, while 3GPP standard [17] combines the last two steps in to one. In some literature handover decision is also separated as an individual step. The point is however to understand what is the purpose of a stepwise procedure. The three components as described in [1] are as follows:

- Handover preparation
- Handover execution
- Handover completion

During the handover preparation, data flows between UE and the core network as usual. This phase includes messaging such as measurement control, which defines the UE measurement parameters and then the measurement report sent accordingly as the triggering criteria is satisfied. Handover decision is then made at the serving eNodeB, which requests a handover to the target cell and performs admission control. Handover request is then acknowledged by the target eNodeB.

Handover execution phase is started when the source eNodeB sends a handover command to UE. During this phase, data is forwarded from the source to the target eNodeB, which buffers the packets. UE then needs to synchronize to the target cell and perform a random access to the target cell to obtain UL allocation and timing advance as well as other necessary parameters. Finally, the UE sends a handover confirm message to the target eNodeB after which the target eNodeB can start sending the forwarded data to the UE.

In the final phase, the target eNodeB informs the MME that the user plane path has changed. S-GW is then notified to update the user plane path. At this point, the data starts flowing on the new path to the target eNodeB. Finally all radio and control plane resources are released in the source eNodeB. The signalling graph for X2 handover without S-GW relocation is given in appendix B. X2 based handover is somewhat of a simplified version of an S1 or I-RAT handover. Thus it is explained here only briefly. A more detailed stepwise discussion of an I-RAT handover procedure along with signalling graphs is given in the next chapter.

3.3 Inter Radio Access Technology handovers

3.3.1 Requirements for I-RAT handovers

There are requirements for I-RAT handovers on both the network side and on the UE side. These requirements have been briefly discussed already but will be revised here more thoroughly.

The basic requirement on the UE side for handovers towards 3G is that the UE supports both 4G and 3G modes of operation and seamless transition from one mode of operation to another. Secondly, the UE must be able to perform I-RAT measurements on other frequencies. This is not a trivial task since the measurement procedure must be coordinated with the eNodeB so that data transmission is not scheduled during the measurement breaks.

Most of the complexity in I-RAT handovers lies on the network side. In addition to measurement coordination, the eNodeB needs to be able to configure measurement criteria and triggering points for handovers and also signal the parameters to the UE. The core network elements in both RATs need to have interworking procedures as will be discussed next.

3.3.2 Network interworking

According to Olsson et Al [5], there are two alternatives to how interworking can be implemented between LTE and legacy 3G networks. The first alternative is to use PDN-GW as the I-RAT mobility anchoring point. In this scenario there are no interfaces defined between SGSN and HSS or SGSN and S-GW. The details of this interworking scenario can be found in [5]. Here we assume that GTPv2 tunnelling protocol is utilized in both networks and interworking is implemented based on this protocol. In this scenario, SGSN interfaces with S-GW via S4 and with MME via S3 as well as with HSS via S6d interface. The signalling Figures for I-RAT handover procedure presented in Chapter 3.3.4 will also assume GTPv2 based mobility. In this mobility implementation, S-GW acts as the mobility anchor, which means that all data passes through the S-GW regardless of which radio network is used. Packets are then, in case of indirect tunnelling, passed from SGSN to RNC and then to the NodeB. The radio access network, that is RNC and NodeB are unaware of the I-RAT handover procedure and merely interpret the incoming handover as intra-3G handover with SGSN relocation. Interworking during the handover will be discussed further in Chapter 3.3.4 as the I-RAT handover signalling graphs are presented. The roaming architecture including

network elements and interfaces for intra-3GPP access as well as data paths during a handover procedure are illustrated in Figure 14.

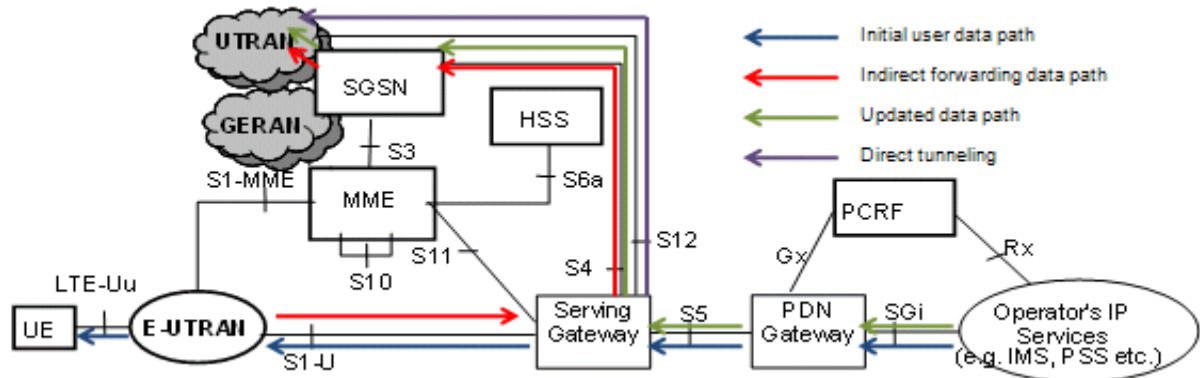

Figure 14: Roaming architecture for intra-3GPP access [17]

As mentioned in the previous chapter, X2 based intra-LTE handovers are used when an X2 interface is present. In case this interface has not been defined between the target and source eNodeB or S-GW relocation is required, S1 based handovers are used. Direct forwarding of DL data packets through the X2 interface cannot be used in this case as the X2 interface does not exist. In this case indirect forwarding between the source and target eNodeB is used.

Buffered packets in the source eNodeB need to be forwarded back to the source S-GW in indirect forwarding operation. In case of S-GW relocation, the packets are then forwarded back to the source S-GW and then through the target S-GW towards the target eNodeB. After the path switch is completed, the resources are released in the source S-GW and the data flows directly through the target S-GW. As X2 interface is defined only between LTE eNodeBs, indirect forwarding is used by default in I-RAT handovers. This may be useful as SGSN is a possible bottleneck due to signalling capacity limitations. [5]

The data flow in I-RAT handover is then similar to that of S1 based handover as illustrated above in Figure 14. In the indirect forwarding phase, the data goes through P-GW and S-GW to the eNodeB, which then buffers the packets. The received packets are then forwarded back to the serving S-GW, which then forwards the packets through target S-GW to SGSN, that forwards the packets to the serving RNC. Finally the packet is forwarded to the target NodeB. Optional S12 interface, as illustrated in Figure 14 can however be defined between RNC and S-GW for direct tunnelling so that the data does not have to pass through SGSN. After the path switch, the incoming data on the P-GW is forwarded straight to the target S-GW that forwards the packets to SGSN on the path towards the 3G radio access network and finally the UE. The data flow directions during an I-RAT handover are illustrated in the signalling

graphs in the next chapter. A good graphical illustration of data forwarding and tunnelling during X2 and S1 handovers is given in [36].

It is naturally possible for a UE attached to UTRAN to perform a handover towards E-UTRAN. In this case, GGSN acts as the IP mobility anchoring point similarly as P-GW does in the other handover direction. P-GW is designed to be backwards compatible to UTRAN networks. Therefore one solution to providing interworking between RATs without upgrading the existing GGSNs to interwork with LTE would be to replace GGSNs with P-GWs in the 3G network. SGSN is then used as the I-RAT mobility anchoring point and the handover is performed similarly as the other way around. Alternatively P-GW can be used as the anchoring point by default with all LTE capable devices that camp in 3G networks. The details of UTRAN to E-UTRAN handover can be found in [17].

3G to 4G handover direction is however not seen as important according to interviews. This is because service continuity can be assured even without this feature, as the 3G coverage is expected to be wider as well as overlapping to 4G. Therefore the call will not drop as it would in case of traversing within an LTE network and crossing the edge of the network coverage area. Handovers towards the other direction would of course be beneficial so that users could be transferred from loaded 3G networks to LTE networks that offer a better quality of service. Nevertheless this feature is not as critical as handover to the other direction. Considering that this feature is not currently supported, it is sufficient that SGSN in the 3G core network is aware of this limitation and will not attempt to perform a handover to LTE. [5]

3.3.3 I-RAT handover measurements

WCDMA systems use different metrics for channel quality measurements due to the differences in multiple access methods. The handover measurement report triggering can be based on i.e values such as. E_c/I_o , RSCP or transmit power in uplink [8]. These values can be used in case of B1 or B2 measurement events discussed earlier. However, the handover can also be triggered by RSRP measurements of the serving LTE cell such as A1 or A2 event, in which serving cell becomes worse than a configured threshold. Handover may then be performed to the best cell, according to prioritization, that is heard, regardless of its radio condition metrics, as long as the conditions are sufficient for a radio connection. This cell can then be a 3G cell.

Compressed mode is used in LTE to measure other frequency carriers than that of the serving cell. This procedure is similar to compressed mode measurements in 3G. Transmission breaks

need to be used scheduled so that user data is not sent in uplink or downlink during these breaks. These silent periods can be scheduled by the base station scheduler at the MAC-layer or alternatively by lowering the bit rate at the higher layers. The details of compressed mode measurements and the performance impacts of compressed mode are discussed further in [37].

3.3.4 I-RAT HO procedure

The handover procedure is initiated as a result of a UE measurement report or handover decision made by the network. Here we consider a measurement report based handover. Upon receiving a measurement report, the eNodeB makes a handover decision that initiates the handover preparation phase. During this phase, the target network prepares the resources for an incoming connection. The preparation phase signalling is illustrated in Figure 15 and explained below in brief. A detailed description can be found from the source 3GPP standard [17].

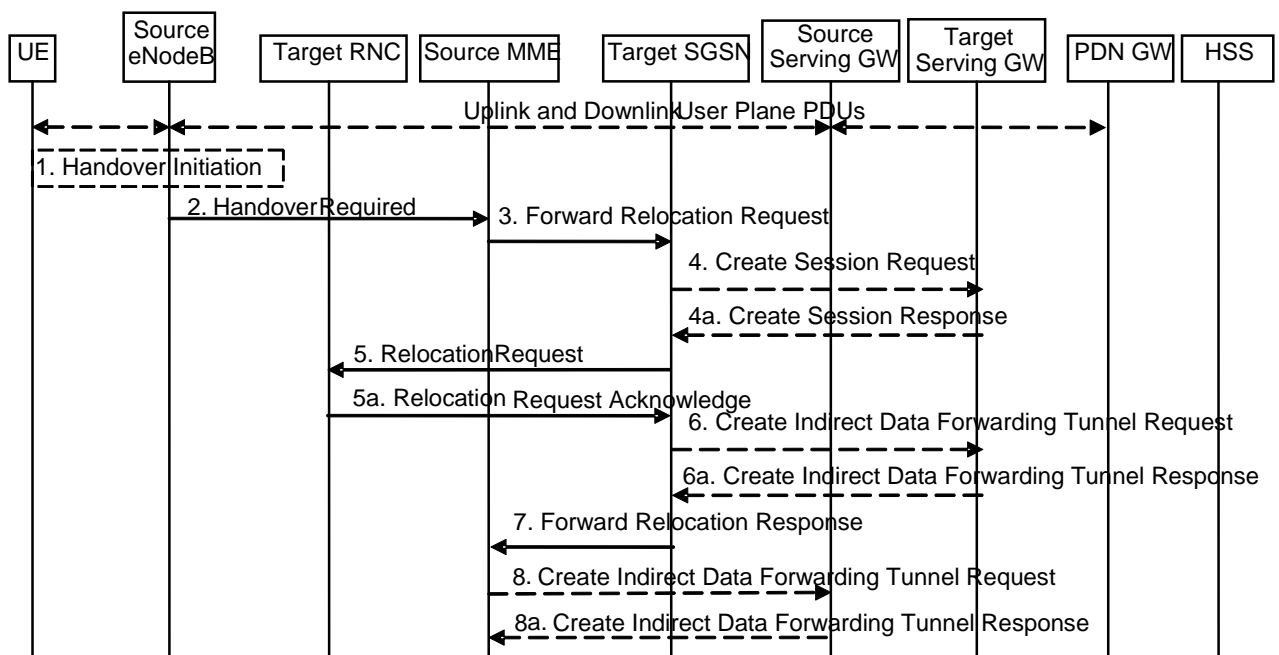

Figure 15: E-UTRAN to UTRAN Inter RAT HO, preparation phase [17]

Step 1: The first step is the handover decision that is made at the serving eNodeB based on the received UE measurement report. For example a report that is triggered by an A2 measurement event. That is, the serving cell RSRP drops below a configured value, e.g. -120dBm for a configured amount of time (TTT). At this point, and during the whole handover preparation phase, user data flows normally between UE and P-GW through

eNodeB and S-GW. It should be noted that a handover decision is not necessarily always made after receiving a measurement report from the UE. For example disabling I-RAT handover functionality or receiving a measurement report from a cell that is not on the neighbouring cell list will not cause a handover trigger upon receiving the measurement report.

Steps 2-3: The source eNodeB sends a ‘Handover required’ signalling message to the source MME. This message requests the MME to allocate resources in the target SGSN, target RNC and S-GW. MME determines that the handover type is I-RAT handover towards UTRAN and sends a ‘Forward Relocation Request’ to the target SGSN. EPS bearer mapping to corresponding PDP Contexts used in 3G networks for QoS differentiation is then performed at the target SGSN. Security context mapping is also performed here. It should be noted that similar bearers may not be available within the 3G network. There may also be a capacity limitation to providing a high data rate bearer. Therefore user experience may be degraded after the handover. [5]

Steps 4-8: Target SGSN decides if the S-GW needs to be relocated e.g. due to PLMN change or interworking issues and sends a session creation message to the target S-GW in case relocation is needed. Then target SGSN requests for Radio Network Resources (RABs) in the target RNC according to PDP and security contexts. GTP-tunnels are also created from S-GW to RNC either directly in case Direct Tunnel is used or through SGSN otherwise. In case S-GW is relocated, also indirect forwarding tunnel need to be created between source S-GW and target S-GW as explained in Chapter 3.3.2. After GTP-tunnel creation the preparation phase is complete and the execution phase can be started. The execution phase of I-RAT handover from E-UTRAN to UTRAN is illustrated in Figure 16.

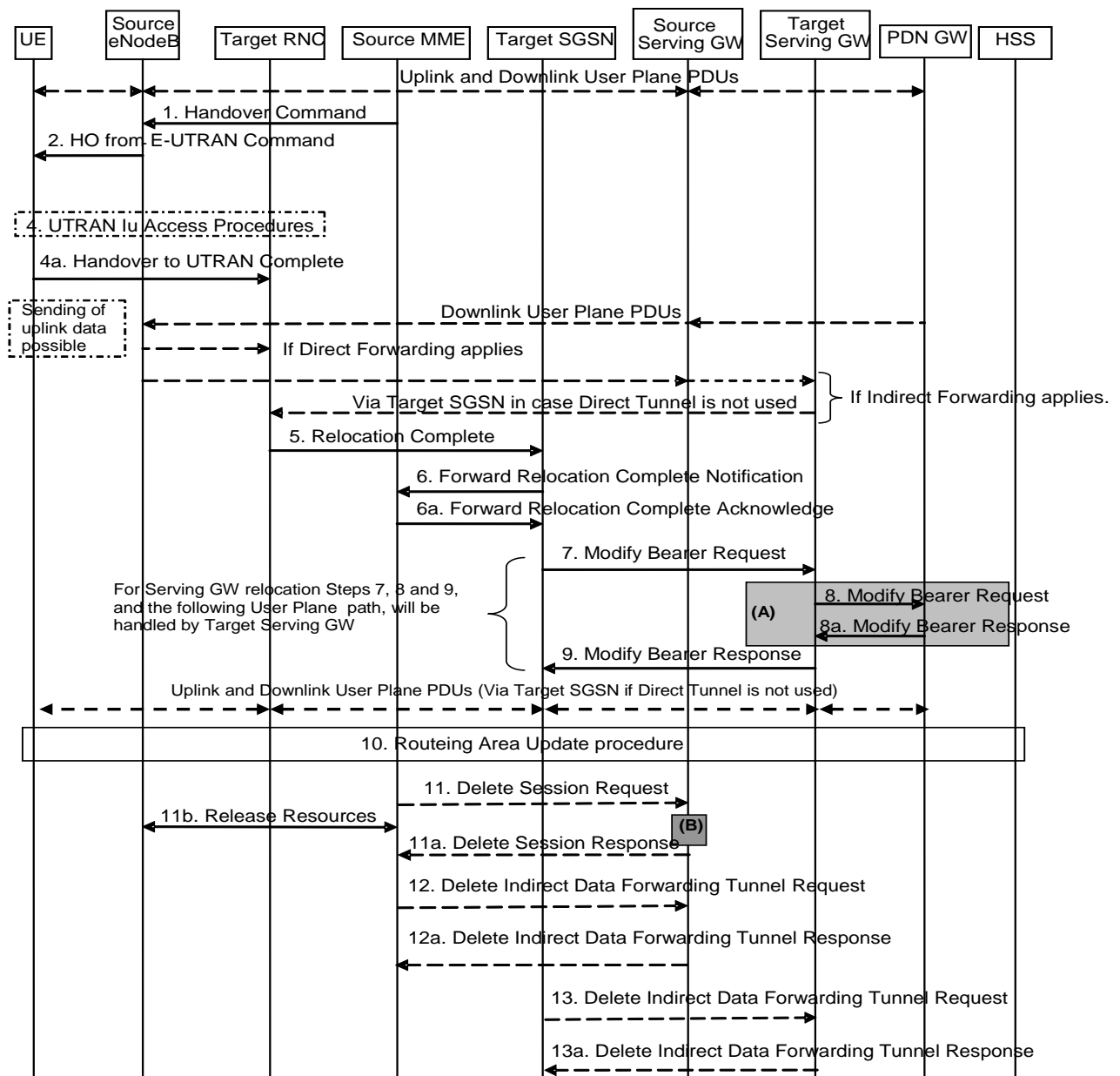

Figure 16: E-UTRAN to UTRAN Inter RAT HO, execution phase [17]

Steps 1-4: Source MME sends a Handover Command to the source eNodeB, which then gives the command to the UE. After receiving the command, user data service is interrupted and the UE shall perform the handover to the target NodeB. The UE performs UTRAN access procedures according to the parameters received in the Handover Command message. In the Handover Command MME also informs the source eNodeB which bearers are subject to data forwarding. Used RLC-layer mode usually determines if the user data should be forwarded or not. RLC-modes UM and AM as defined in Chapter 2.5.3 that are used for Non

Real-Time (NRT) data such as file download or Http web browsing are generally subject to data forwarding, which means that the handover is lossless. Real-Time (RT) data such as streaming services utilize RLC TM mode of operation and are not subject to data forwarding. Therefore any data sent in downlink will be lost during the service interruption time. The forwarding of DL data packets towards the target RNC is started after the handover to UTRAN complete message that is sent by the UE after a successful access procedure to the target 3G cell. Sending of UL data is also possible at this time. Handover delay time and assumptions for user plane interruption time in inter-RAT handover procedure will be discussed further in Chapter 5.

Steps 5-9: Target RNC sends a Relocation Complete message to the target SGSN to inform that the handover from E-UTRAN was successful. Target SGSN is now prepared to receive data from the target RNC in uplink and forward it towards S-GW. Target SGSN then informs the source MME that the UE has handed over to the target network side. MME can then start a timer that is set to expire after the data path is switched so that MME can release all EPS bearers for the UE. In step 7, the target SGSN will inform the target S-GW that the target SGSN is now responsible for all EPS bearer contexts the UE has established. Target S-GW then informs P-GW of a possible S-GW relocation after which the target S-GW acknowledges the bearer modification request to the SGSN. After this, the user data flows between UE and P-GW in the updated path through RNC, SGSN and target S-GW.

Steps 10-13: After the timer set in the source MME started in step 6 expires, MME will request the source eNodeB to release all resources related to the EPS bearers that the UE was utilizing. MME will also request the source SGSN to delete the indirect data forwarding tunnel created in the preparation phase. After this, the UE is connected to the target 3G cell and all radio resources are released in the source LTE network. The handover procedure is now completed and user service is continued, hopefully without any noticeable interruption break.

4. LTE FUNCTIONALITY AND PERFORMANCE TESTING

This chapter explains the rationale for LTE system testing and verification. The concepts introduced in this chapter are for the most part based on interviews of senior test engineers, internal documentation and on individual on-the-job learning. This chapter relates the literature study to the practical test work of an actual live LTE network while concentrating mainly on handover testing. It also brings the Inter Radio Access Technology handover test planning work, presented in the next chapter to a wider context. The contents of this chapter are as follows. Chapter 4.1 presents the motivations and basic concepts of test work that is done for any new hardware or software implementations in end-to-end system verification. Chapter 4.2 introduces the tools and methods that can be used in the testing. Finally Chapter 4.3 discusses the challenges that test engineers are likely to face when testing the features and functionalities, such as I-RAT handover, implemented to an LTE network.

4.1 Introduction to LTE performance testing and system verification

4.1.1 General test practices

Any new software or hardware component introduced to a given part of an LTE network needs to be tested and its functionality and performance needs to be verified. Testing is done in several stages that are introduced on a general level in the following paragraph. As mentioned, the level of abstract in this document is at a system level. Therefore e.g. the details and practises of individual software part development and testing, often called module testing, are not discussed here. We start the discussion here from a component level that includes various software parts in a given network component that are functional at least to some extent.

First the component needs to be tested individually so that it works in accordance to the set requirements and targets. This stage is referred to as System Component Testing (SCT). After the initial SCT, the software or hardware needs to be tested for interworking with other network elements and components. At this stage referred to as Integration and Verification (I&V), simulators may be used instead of real network elements. In System Verification (SyVe) level, real network elements in a fully working live LTE network are utilized. At this stage the network functionality and performance is tested. This stage is however performed in a laboratory environment. Usually radio signals are transmitted in RF cables instead of emitting radio waves to the air. Finally in the Field Verification (FiVe) stage, real live

networks with a network of cells are utilized and testing is performed using directive or omni-directional antennas for air interface transmission. This is done to simulate a real operator network and to gain results that are comparable to customer test results. In practise, each test level consists of several sublevels and includes complex individual processes and practises. The goal here is to introduce the test work on a more general level and the details of each test stage are left outside the scope of this document. The test stages on a general level are summarized below.

- System Component Testing is done for each new software or hardware component individually.
- Integration and Verification phase is performed to ensure that the new component supports interoperability with the existing components.
- System Verification is meant to provide performance figures from a fully functioning real network in a laboratory environment.
- Field Verification provides results that indicate the networks' end-to-end performance in real radio conditions. The test conditions, and thus the test results are comparable to tests in a live operator network.

The initial goal of testing is to find any critical faults in the network elements. Faults in hardware or software are then corrected, usually by rewriting some part of the software code, and retesting is performed. When the network is stable enough, performance testing may be commenced. Performance testing is usually done by executing a series of test cases that are logged, documented and post-analyzed. For example a test case could be to measure downlink TCP throughput with 10 stationary UEs. In this test, the throughput is measured and compared to earlier results. Then it can be considered if the results for user throughput measurements in the given radio conditions satisfy the set targets. It may happen for example that the throughput is worse than expected and after a log or trace analysis a fault is found that the used MCS level is not the correct one that should be used according to specifications for these radio conditions. This fault then needs to be corrected and the correction retested accordingly. Criteria for passing the test cases need to be satisfied on a vendor target level as well as on level set by 3GPP standards.

The implications of upgrading, e.g. a part of the eNodeB software such as Operation and Maintenance (O&M), which is a base station control and maintenance software part, can often be unexpected. It is for example possible that after the upgrade, cell user throughputs are severely degraded even if the software part was not supposed to have an effect on

throughput, and the reasons for this behaviour are hard to isolate. Therefore thorough end-to-end system testing that involves all the network elements should always be performed for any new upgrades, or at least for software that is released to a customer. Finally when all the test cases in performance testing are passed, stability testing can be executed to test the network performance in the long run. Test cases that run for days or weeks at a time can be done at the stability phase. The performance data is collected and analyzed statistically.

Stable and well performing hardware and software can then be delivered to a customer, which usually performs tests of its own. Fault reports may then also originate in the customer side as a result of their own testing. In fact, it is rarely possible to find and fix all faults to customer release software before it needs to be delivered. A fault condition originating on the customer side then needs to be repeated by creating a similar test environment than that of the customers'. Fault correction and retesting are then done as usual before delivering the correction to the customer.

4.1.2 Motivations for testing in a laboratory environment

Testing in a controlled laboratory environment is the basis of any test work. It is easy to create an artificial test environment using e.g. network element- and UE simulators, RF cables and fading simulators. In a controlled environment certain test parameters can be fixed so that testing can be isolated to a certain functional area, such as testing a certain protocol or perhaps the performance of a stationary UE that is not subject to outside interference. By connecting the stationary UE to an eNodeB with RF cables, the impact of fading and mobility to performance can be mitigated. Faults may then be easier to locate in a more isolated test environment with fewer variables.

In addition to providing a test bed for controlled and isolated tests, the benefit of laboratory environment is that testing can be highly automated. Automation provides fast test results and lots of test data that can be statistically analyzed. The downside of laboratory testing is that simulating real radio conditions is relatively difficult. It may happen that some faults can only be identified in more realistic radio conditions. Testing is generally performed first in the laboratory before field testing is executed.

4.1.3 Motivations for field environment testing

The main motivation for field testing is that tests for locating faults and measuring performance in a laboratory are not always reliable compared to tests in the field. Good simulators come close to creating radio conditions that are similar to real conditions. It is

however not easy to simulate real radio conditions with various fading scenarios, moving UEs and interference from nearby cells and UEs. Some fault conditions found in field testing simply cannot be located in the laboratory. For example some eNodeB kernel crashes have occurred in field conditions and reproducing these fault conditions has not been possible in laboratory conditions. For these reasons testing in the field is important to verify that the network works in the same conditions that live operators have. The downside of field testing is that it is relatively slow and manual compared to laboratory testing.

Handover, as well as general mobility testing has an important role in field verification. Handover signaling protocols and interworking procedures can be reliably tested in the laboratory but reliable tests for air interface performance should be done in the field, in real radio conditions. This is because the environment for radio transmission is a whole lot different in the field than it is in the laboratory. Neighboring base stations provide interference in downlink and possible UEs that are situated in the test network provide interference in uplink. Testing in the laboratory on the other hand is usually done with only two cells with two sets of tunable attenuators and RF cables, which makes the scenario a whole lot different. Testing of handover prioritization, blacklisting and neighboring cell parameters are not possible in this scenario. User mobility also sets more stringent requirements for the network. Moving UEs need to be synchronized and their timing alignment needs to function up to highway speeds so that the sent packets are received within their transmission window. The call needs to be handed over to a new cell before running out of coverage in the source cell. Neighboring cell configurations, network dimensioning and handover parameters need to be correctly configured before any test work can be initiated.

4.2 Tools and methods for testing

4.2.1 Test tools for laboratory testing

Testing in the laboratory can be done with either real network elements or simulators as already discussed previously. System verification is however done with real network elements in a fully functioning network and thus discussion of simulators and network element functional testing (SCT) or testing for element interworking (I&V) is not continued here. Nevertheless, fading simulators can be used also in this stage for simulating real radio conditions, as well as call generators in some cases, when they are available.

Usually there are several eNodeBs in the laboratory that are mainly used separately for testing several different features simultaneously. Handovers are then usually tested by

connecting two eNodeBs to an attenuator box with RF cables so that the received signal strengths from the base stations can be adjusted. The output signal of the attenuator box is then transmitted to the UE, again with RF cables. The attenuator box output can then be either manually adjusted or automated with software scripts. Adjusting the attenuation high from the serving base station and low on the target base station side will trigger the handover. More than two cells can be connected to an attenuator box but setting up such as a test configuration takes a lot of time and resources. In addition a fading simulator may not have support for several incoming signals.

Testing of I-RAT handovers can be performed in a similar fashion as described above. The difference is that instead of two eNodeBs, only one LTE eNodeB and a 3G NodeB are used. Network core elements and their interworking as well as multimode operation of the UE needs to be ensured as discussed in Chapter 3, so that handovers are possible. The base stations can be then connected to a fading simulator with RF cables. In fact a fading simulator can also perform the functions of an attenuator box and on top of that it provides more realistic scenarios for simulating real, fading and varying radio conditions. The output signal of the fading simulator is then connected to the UE. Handovers can be triggered by controlling the simulator output signal. The user data as well as UE control- and signaling data can then be captured with various tools from different interfaces of the network, e.g. the widely used freeware, the Wireshark-tool. The readily available freeware may not contain the decoding functionalities for 3G/4G protocols or IPsec and therefore the vendors may need to develop the tool further. Here we assume a Wireshark implementation with these decoding functionalities.

The main focus of research in this thesis is analyzing the captured data transferred on the air interface, which despite the enhanced performance, remains the bottleneck link and the most unreliable part of the network. Similar tools for capturing and analyzing Uu interface data can be used in both laboratory testing and field testing. These tools will be discussed further in the following chapter.

4.2.2 Field Environment test tools and settings

Field testing is generally done as drive tests with a set of UEs placed in a test car. The car generally drives around the coverage area of the radio access test network, but naturally stationary tests can also be performed with the car. The drive route needs to be optimized and neighboring cell configurations need to be set up according to the planned handover locations.

This thesis will not discuss the details of network planning and dimensioning. Therefore at this stage it is expected that a network of base stations already exists. The BTS antennas are expected to be located on high building rooftops or link towers that are close enough to each other so that there are no severe coverage gaps in the network. Network planning and dimensioning are expected to be well optimized.

There are however methods for improving the network performance, even after the network is already in place. Carrier power of the base stations can be configured higher in case coverage gaps are found or lower in case of too overlapping cells. Base station antennas can also be either manually, or using automatic tools, turned or tilted. In a test network, these methods are not really an exact science, but more of a trial and error based optimization method. Operators are expected to use more advanced and exact methods for their network optimization. Handover parameters as well as cell reselection parameters can then be configured according to the network dimensioning for optimized performance.

Wireshark is an important tool that can be used to capture messages on both the UE side and the network side. It is currently more often used to capture messages on the core network side to monitor the IP-layer traffic. A good set of filters is required since there are such large amounts of data in the core network that the most important messages will go unnoticed without the correct filters. There are other tools that are more specified to monitoring air interface, as will be discussed in the following paragraph. *Wireshark* is however useful for measuring handover delays from the UE side. The procedure for measuring handover delay with *Wireshark* that has been used in intra-LTE handover cases is explained in detail in appendix C. A similar procedure can be used also to measure inter-RAT handover delay. *Wireshark* can be used to determine the user plane delay, which is often interesting to the operators. It is however not the best tool for debugging and fault analysis purposes as it does not capture messages on lower layers such as MAC-layer retransmissions. Handover performance however depends heavily on MAC-layer performance. A more optimized tool for MAC-layer performance analysis will be introduced next.

Another important tool currently used in test measurements is an analyzer software for TTI-traces. This tool is used to obtain information about the behavior of MAC-software running in an eNodeB. TTI-trace provides means to get data on a TTI level, which is once per each 1ms. This would not be possible with ASCII logs without major performance losses [38]. TTI-trace tool is most useful in analyzing MAC-layer performance and functionalities on MAC-layer such as HARQ and CQI reporting. It cannot be used to decode the payloads of

the monitored data packets as it merely collects header and control information. There is no user interface in this tool nor is there support for real time monitoring. Traces can however be post-analyzed using a spreadsheet tool or automatically parsed to generate various performance graphs. Most important of these graphs being the UE and cell level throughput, which more or less indicates the overall performance of the network. Handover delay testing is somewhat challenging with TTI-traces since the traces are taken on the base station side and the base stations are not expected to be precisely synchronized. However these traces can be analyzed in detail to locate any faults and abnormalities of the MAC-layer functionality and performance during a handover. This tool can be used to take TTI-traces also from a 3G cell, which makes it an excellent tool for I-RAT handover testing. With proper synchronization, even handover delays can be measured.

An example of TTI-trace throughput graph is illustrated below in Figure 17. The Figure illustrates cumulative throughputs of 10 UEs in a downlink TCP throughput test in a single cell with certain radio conditions. In between TTI-trace logs there is a waiting period before a new log is started, which is why there are gaps in the figure.

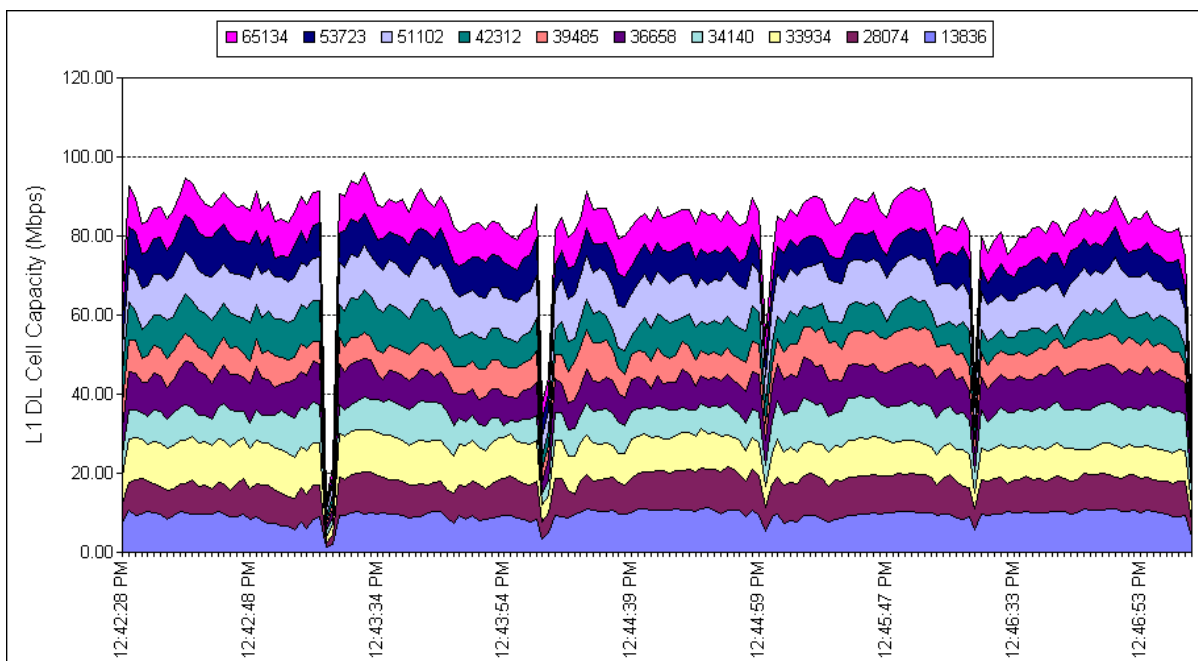

Figure 17: Cell Capacity (Mbps) (BLER considered)

Handover signaling message monitoring as well as air interface performance measurements can be performed with various tools. One of these tools and the most important one currently used is the XCAL software tool. This tool, introduced in [39], can be used to capture messages on the UE side. XCAL can be used for capturing signaling messages as well as performing and logging of real-time performance measurements. There are also ready scripts

for running some basic test scenarios. Scripts can also be configured to accommodate most of the specific testing needs. XCAL-MTS is then a device that includes 10 PCs that can be monitored simultaneously with a single laptop that connects to the device. The measurement and signaling figures provided by 10 separate XCAL monitoring tools can then be combined to one screen. The monitoring laptop can also be remotely controlled with a reliable 3G connection to the laboratory, thus eliminating the need for test engineers to actually be in the car, and being an important step towards test automation. The PCs as well as the UEs can also be remotely reset, which is often necessary when testing new equipment and software. The downside of XCAL is that it does not support UE simulators and thus relatively expensive commercial LTE devices need to be used. Intra-LTE handover test measurements using a single PC with an XCAL-tool and commercial LTE device are illustrated in Figure 18 and explained below. XCAL also supports 3G as well as 2G modes of operation and therefore it can be used also for I-RAT handover testing. A similar tool used for air interface message capturing and analysis used in current 3G testing, and possibly in the future for LTE testing as well, is the *Nemo-tool*.

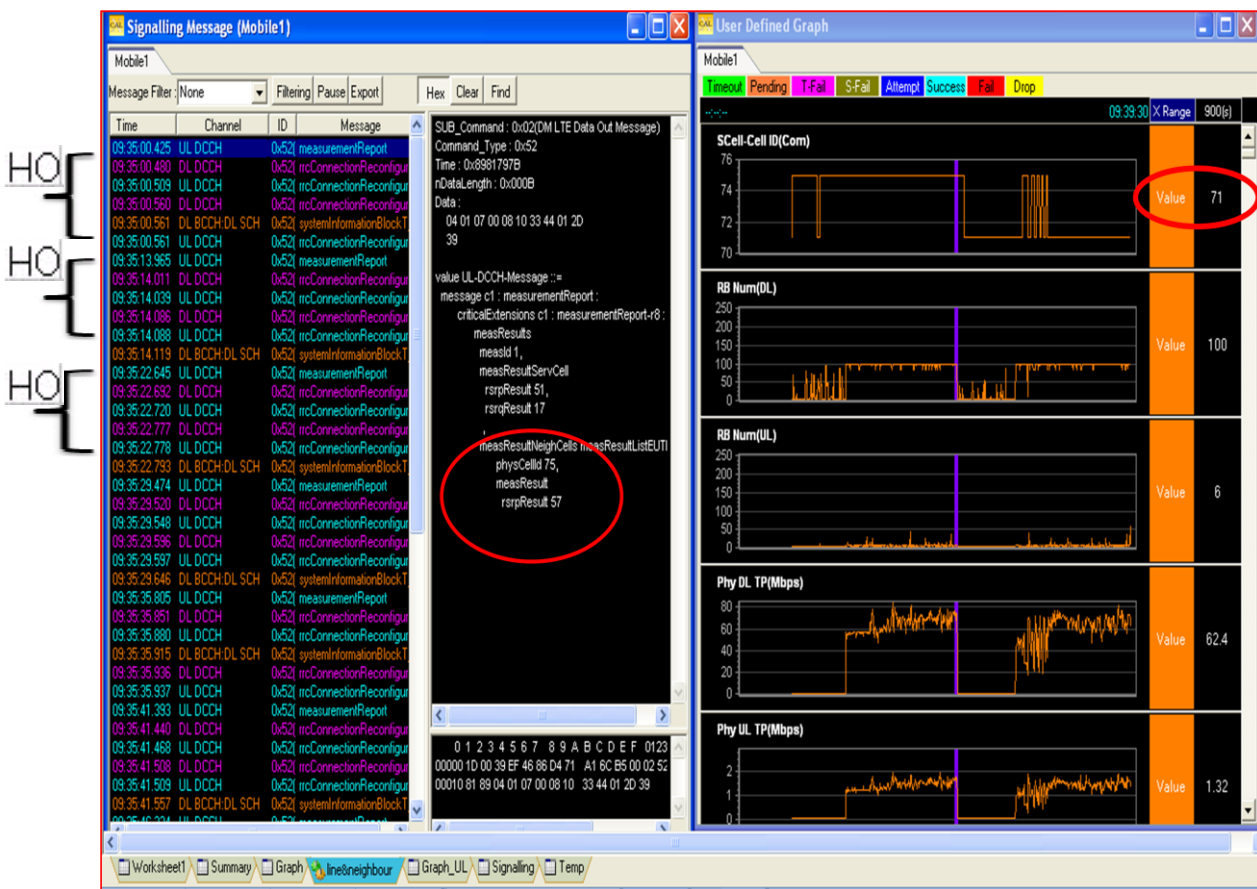

Figure 18: Screenshot of signaling and measurement Figures with an XCAL tool

This particular Figure illustrates the signaling flow of a series of intra-LTE, inter-eNodeB handovers via X2 interface as a part of a handover delay measurement test case. The details of this test case as well as analysis on the results are published in [40]. This document, co-written by the undersigned, provides a good reference to intra-LTE handover measurements as well background for I-RAT handover measurements.

On the right hand side of the figure there are the user defined graphs. An impressive number of measurement quantities such as serving and neighboring cell CINR, RSRP and used MCS level to name a few, can be defined here, depending on what is interesting to measure in a given test case. The figure above defines uplink and downlink throughput and utilized resource blocks, as well as serving cell ID. On the left hand side, the UE side signaling flow is presented. The contents of a given binary signaling message can be decoded if the protocol functionality is known and the message is not encrypted. A measurement report for example is a relatively simple signaling message and contains basically the RSRP measurement value and the measured target cell ID, as highlighted in the figure. As explained previously, measurement report results to a handover decision made at the serving eNodeB, which then sends a handover command to the UE.

In this implementation handover command message corresponds to 'rrcConnectionReconfiguration' message that initiates the handover process on the UE side. For connection establishment and parameter exchange purposes, two of these messages per handover are sent in downlink and acknowledged in uplink. Handover procedure is considered complete after the second acknowledgement, which contains e.g. the measurement parameters and configurations in the target cell. The handover signaling delay is then calculated from the timestamps of the first reconfiguration message in downlink and the second uplink acknowledgement. It is often difficult to monitor several measurement quantities in real time and therefore the test is often logged and post-processed for in-depth analysis afterwards. Initial and instantaneous results can however be obtained, as well as a general idea whether or not the performance is according to the set goals.

The downside of XCAL is that it captures the part of the signaling flow, which is visible to the UE. As can be seen from the signaling graphs presented in Chapter 3, signaling messages sent or received by the UE, are merely a fraction of the whole signaling scenario. An important tool for analyzing signaling from the eNodeB side in detail is a BTS analyzer tool. This tool has been used also in 3G testing, which makes it a useful tool in I-RAT handover testing.

In addition to the tools already presented, there are internal counters implemented within the eNodeB that can be used to calculate certain KPI values such as handover success rate, call drop rate and average throughput. The details of these KPI values will be discussed further in Chapter 5. The counter values of every configured base station are then reported periodically to an Operation Management System (OMS). These counter values can then be fetched from the OMS and analyzed statistically using e.g. spreadsheets. Currently there are no such counters in the implementation for handover delay or any I-RAT handover performance metrics at all for that matter. Adding the counters for I-RAT handover performance might be a beneficial step towards I-RAT handover test automation. The implementation of automation features may take some time and it is expected that I-RAT handover testing is somewhat manual in the beginning.

4.3 Challenges in LTE end-to-end testing

4.3.1 Practical challenges

As discussed in Chapter 2.3, the design principle of LTE system architecture, is a flat, simplified network model that is based solely on packet switched IP-protocol. Regardless of the simplified core architecture, the complexity of the network elements and devices continues to rise. Removing the RNC from the core architecture actually means that the complexity of one centralized network element serving hundreds of base stations is moved to every single eNodeB in the network. Performance wise this is of course better as it reduces the processing times and from a higher level looks simpler. High data rates, low latencies and complex air interface techniques such as MIMO-operation introduced in Chapter 2, all create challenges for both network and terminal equipment.

LTE release 8 radio access technology has been allocated several frequency bands and it supports six different bandwidth allocations from 1.4MHz to 20MHz. The advertised peak data rate of 100Mbps can only be achieved with the maximum 20MHz bandwidth allocation. In many regions there is however currently no 20MHz spectrum blocks available and consequently a smaller spectral allocation needs to be used. LTE also support both FDD and TDD modes of operation as well as a number of MIMO operation modes. Basically all of these features need to be implemented and tested. Providing test equipment that supports these complex RF capabilities and features with reliable test capabilities remains challenging. Providing UEs that support several RF bands may also prove to become a challenge. The development of the test equipment is at an early stage. Therefore the behavior of a test device

can be unstable, causing biased results. Another considerable challenge is that the test engineers should have extensive knowledge of the technology standards and implementation features so that the tests are performed using the right methods. After all, performing MIMO tests without knowledge of how MIMO is configured and thus using a transmit diversity only transmission configuration is relatively useless. Training new test engineers gets more time consuming as the complexity of the test work increases. A wide set of complex new features also means an increased amount of test cases that need to be run. Due to increased number of test cases, test automation becomes an increasingly important issue. [41]

There are numerous practical and sometimes unexpected challenges that even senior test engineers are likely to face in their work. The high data rates of LTE result in Wireshark data capture log files in the order of gigabytes if correct filtering is not used. Analyzing these amounts of data is difficult and time consuming. Data rates of up to 100Mbps also create performance pressure to both the terminal equipment side as well as the network side. For example a UDP-server that is used in the test can get overloaded when the amount of downloading UEs goes above 5. Throughput degradation due to server or terminal equipment limitations can be unexpected as the results are distorted regardless of the actual network performance. With the increased amount of test cases there may not be time to test all the features and functionalities of every new software release.

4.3.2 Challenges in I-RAT handover field testing

One of the major challenges causing impairments in I-RAT handover testing as well as mobility testing in general is that the test network is usually relatively small compared to live operator networks. This could mean that there are somewhere around 5-10 test base stations in the network. Therefore it is often the case that the handover target cell is located at the cell edge and there are not as many interfering neighbour cells as there are in a live operator network. In addition the cells in the test network are usually not loaded, which means that there are no active users in the cell. Unloaded cells have no ongoing transmissions and therefore there is no neighbouring cell interference in downlink or uplink. This makes the handover case different from a handover in a live network, which most likely is at least partly loaded. Also the behaviour of the eNodeB may differ according to increased CPU load, which can cause faults.

The behaviour of the handover procedure can be unexpected in many ways. For example a fault that has been under investigation was found in intra-LTE handover testing that in a

certain RSRP level in relatively good radio conditions, call drop rate was high during handovers. Considering that there may be only a couple of locations in a small field test network where I-RAT handovers will be tested, this kind of a fault scenario could be missed. Different handover related parameters and their impact to network performance should be tested one parameter at a time. Changing several parameters at the time may not indicate which parameter change was actually useful. However testing several different parameters one at a time is relatively slow. Therefore gradual and well documented parameter testing should be performed continuously whenever there is extra time between actual test case executions. The correct functionality of the parameters of course need to be verified and the goal in the test network is not simply to find the optimal set of parameters that give the best performance but also to test the functionality with a poor set of parameters.

Testing of different radio access technologies is often done by different teams within the organization. Competence of a certain radio access technology is thus focused to a certain test team that may not have any knowledge of the other technology involved in the I-RAT handover. Analysis of handover between these technologies should be performed on both the source and the target RAT side. Handover testing between technologies is however merely one small part of the entire test process and it should not interfere with the work of a team that is performing standard testing within the radio access technology of their expertise. Coordination between the test teams should be encouraged to avoid any confusion. Cooperation should also take place so that the results can be correctly analyzed from both radio access technology sides. These challenges in I-RAT handover testing will be addressed further in the next chapter as the test execution plan is presented.

5. TEST PLAN FOR FIELD ENVIRONMENT I-RAT HANDOVERS

In this chapter, the discussion is focused on field environment testing of Inter Radio Access Technology handover performance. A test execution plan for performing I-RAT handover performance measurements in the field test network will be presented. The methods and tools for performing these measurements will then be introduced in detail. Finally the definitions and test procedures of KPI value measurements will be explained. The contents of this chapter are as follows. Chapter 5.1 presents the test plan for I-RAT handover field environment testing. Motivations for the given plan are first explained and a detailed map of handover locations and the involved base stations is presented. Chapter 5.2 explains how this environment can be utilized as a test bed for field environment testing. Tools and methods that will be used for the test measurements will be introduced here. Chapter 5.3 then defines the KPI measurement values and test procedures that are of interest to provide exact statistical data. This data can then be used as an indicator of how well this feature is actually working and what are the areas of improvement.

5.1 Presenting the I-RAT handover field environment test plan

5.1.1 Motivations for the developed test plan

The first issue in the planning process for Inter Radio Access Technology handover field environment testing was to decide where and how the testing would take place. Basically the choices were that either the existing test networks would be used in I-RAT handover testing or a new test network dedicated specifically for I-RAT handover cases would be rolled out. The latter option would provide a dedicated test bed so I-RAT handover testing would not interfere with individual RAT testing. This would however mean that an entire network would have to be rolled out and maintained, which would be relatively costly. The network would have to be rolled out further away from the existing network coverage area, which is conveniently located near by the office. In practice this means that it would take considerable time and effort to actually drive to the I-RAT network coverage area to perform any test work. It is expected that I-RAT handovers will not be tested continuously but more like on a need to now basis. Due to these considerations, it is clear that a new a new network rollout should be avoided in case the existing network can be used somewhat reasonably for I-RAT handover testing.

This test plan is developed based on the use of existing test networks as a test bed for I-RAT handover testing. This option does not require an expensive new network rollout and minimizes the drive test distances, and therefore shortens the test setup- and execution times. As will be shown in the next chapter, the existing test network can indeed be used as a test bed and therefore there is no need for a new dedicated test network. Coordination is however needed between the test teams so that confusion and interference to other test work can be avoided.

5.1.2 Planned test environment

Even though discussion in this thesis focuses on LTE to 3G handovers, planning needs to be considered in coordination with 2G test work as well as testing of the separate I-HSPA network. This is because I-RAT testing is required towards all radio access technologies and thus the plan should not rule out the possibility to test, e.g. LTE to 2G handovers. Figure 19 illustrates the test bed for I-RAT handover field environment performance testing. For simplicity- and confidentiality reasons, only the base stations that are involved in the plan are included in the figure. The figure will be explained in detail below.



Figure 19: LTE field network and I-RAT Handover locations

The above figure illustrates a part of the test network that is of interest when considering I-RAT handover testing. The map is located in Leppävaara area, in Espoo, Finland. From radio conditions perspective, it may be considered as an urban/small city environment. The black arrows illustrate the main antenna directions of cells in the LTE field verification test network, and are numbered for distinction. The colored, and numbered, beams represent directive antenna cells of other radio access technologies than LTE. These RATs are color coded for distinction green, red and blue for GSM, 3G (WCDMA) and I-HSPA cells respectively. The blue arrows indicate the driving direction and point to the red dots that indicate approximately the expected handover location. The handover points have been chosen based on measurements of both the target RAT and the source RAT with XCAL for LTE and Nemo for 3G and 2G. This measurement procedure is illustrated with an example measurement presented in appendix D, which is made at handover point C. The handover points are explained in detail as follows:

Handover point A – LTE to 3G handover:

When driving towards handover point A according to the direction of the blue arrow, the UE is expected to camp in Upseeri LTE cell 352. The RSRP level drops dramatically as the UE approaches the handover point. This corresponds to a real operator scenario of a user driving out of the network coverage of a hot spot LTE network. Measurements performed with an XCAL-tool indicate that the serving RSRP is around -120dBm here, which could be set as the threshold for an A2 coverage handover. This signal strength is good enough to maintain a call but dropping well below -130dBm will cause call drops. A neighboring cell relationship needs to be established between Upseeri LTE cell 352 and Sello 3G cell 3. According to measurements performed with Nemo-tool, the 3G radio conditions are for RSCP, from -70dBm to -80dBm and for Ec/Io between -6dB and -9dB. Without going in to the details of these values, these radio conditions are basically relatively good. Any other neighbor relations should not be created so that the handover direction is known and there are no uncontrolled handovers to unwanted directions.

Setting the A2 handover RSRP threshold to -120dBm and TTT value some small value i.e. below 1 second, a handover should take place between the neighboring Upseeri LTE cell 352 and Sello 3G cell 3. Handover can then be performed towards the other direction between these two cells. In this case it may be needed that the LTE cell is prioritized over the Sello 3G cell 1 so that the handover direction is correct. Again we have a good operator case for testing

LTE over 3G RAT prioritization. The handover related parameters can be optimized by trying out different parameter sets.

Handover point B – LTE to 2G handover:

Handover point B is reached when approaching it from the west on route 110 as illustrated in the map. The UE will camp in Upseeri LTE cell 353 along the way. The radio conditions will gradually degrade as the car comes closer to the handover point, which is located near an intersection with a road leading to Hippos. At handover point B, the serving cell RSRP drops below -110dBm, which can be set as the initial threshold for an A2 coverage handover as in the LTE to 3G handover case. The challenge in this case is that an LTE cell in Hippos can be heard by the UE at this point, which means that a lower A2 threshold could result in an A5 better cell handover to Hippos LTE. The prioritization needs to be done in such a way that an A2 handover from Upseeri LTE cell 353 is set to prioritize a GSM cell. Neighbouring cell definitions are then configured between LTE Upseeri 353 and 2G Hippos cell number 3, which provides good radio conditions. In case the prioritization feature is not supported, the backup plan is that the LTE cells in Hippos are blocked for the duration of the I-RAT handover tests. Again, handover towards the other direction can be performed between the same two cells. Any other neighboring cell configurations should be avoided in order to create a controllable environment for the testing.

Handover point C – LTE to I-HSPA handover:

Handover point C is located on a hill behind a large office building. When driving towards this point according the direction of the blue arrow, the UE is camping in Säteri LTE cell 332. Driving behind the building and up the hill, the serving RSRP will start to drop dramatically. At the handover point the RSRP is expected to be below -120dBm, which can be set as the threshold for an A2 coverage handover. There is no LTE base station in this area, which makes it a good coverage handover location. Defining a neighboring cell configuration between Säteri LTE cell 332 and Vänrikki I-HSPA cell 2 will cause the UE to perform an I-RAT handover to I-HSPA at handover point C. Initial measurements for the I-HSPA radio conditions in this area are presented in appendix D. The measured RSCP is between -90dBm and -100dBm and E_c/I_o between -9dB and -12dB. These conditions are more than sufficient to sustain a packet call. Again handover towards the other direction can be done simply by driving towards the other direction.

Mäkkylä site, located in the northwest corner of the map, could be used as a backup location for coverage based I-RAT handovers. There are for example both LTE and GSM antennas pointing towards the same direction. This scenario could be one interesting test case since it can be expected that operators will use the same sites for their new LTE base stations as for the existing GSM sites. Interference as well coverage area testing between these RATs operating in different frequencies can be performed in this test bed. The details of how Mäkkylä site can be utilized are however left for future work. The handover points are summarized below in Table 4.

Table 4: Planned I-RAT field handover points

Handover point	source cell	target cell	A2 measurement trigger
A	Upseeri LTE 352	3G sello 3	-120dBm
B	Upseeri LTE 353	GSM Hippos 3	-110dBm
C	Säteri B LTE 332	I-HSPA Vänrikki 2	-120dBm

5.1.3 Coordination of I-RAT testing and intra-LTE handover testing

The goal of the introduced handover plan is to provide a simple and easy solution for the execution of I-RAT handover testing. The test network is relatively small and there are a limited number of places where the handovers can take place. There needs to be set locations for handovers towards all the RATs being tested while I-RAT handover testing should not interfere with testing within the individual RATs. The handovers directions also need to be controlled so that both the source and target cell are known beforehand. Otherwise the UE can ping-pong around the cells, which makes exact performance measurements impossible to perform. This problem is tackled by configuring only a few know neighboring cell relations and triggering parameters so that the handovers occur in predestined locations.

The idea is that this configuration is permanent on the network side and thus only the UE side needs to be reconfigured according to the specific testing needs. This means that for example when only intra-LTE testing is performed, the UE is configured to an LTE-only-mode. This way, the UE shall not measure any inter-RAT neighbors even if it receives these on the broadcast channel in a neighboring cell list. There is no need to do time consuming base station configuration changes and resets. The coordination between teams that are testing different RATs is however still required so that the KPI results etc. are not distorted by unexpected I-RAT handover tests.

5.2 Plan for test execution

5.2.1 Test execution plan

The test environment presented previously should provide a test bed that satisfies most of the testing needs. If there is a need for some special cases such as a certain radio environment, it should not be a problem to create one in Mäkkylä for instance. This can be done by adjusting the base station parameters, tuning the antenna directions and tilts as well as changing the downlink carrier transmission power. Initial testing of the network, fault finding and correcting as well as network parameter optimization should be performed at first. When the network is stable enough and it is verified that the handovers occur in the planned handover points, KPI measurements can be commenced.

The testing should be done in several layers. This means that at first, initial testing and data collection should be done in some quantities. After initial tests, more detailed testing of specific features can be started. Finally the tests should be logged and the logs analyzed in detail. Faults are generally found and isolated from detailed log analysis. In theory only faults that can be found in field conditions should be isolated in the field verification phase. For example the functionality of the handover signaling protocols should be tested in the lab, in SyVe phase or even before and thus they should already work according to specifications in field verification phase. In practice however some faults that should be corrected in lower test levels always make it to field verification phase. Located faults are isolated and reported regardless of being found in SyVe phase or in FiVe phase.

Drive testing with an XCAL and one UE in RRC connected mode would be a good tool for initial testing. XCAL can be used to get an overall idea in real time of how the radio conditions vary close to the handover point, how the throughput figure looks like and how the signaling figure looks like. Handover signaling figure can be verified and signaling delay can be calculated from the signaling message timestamps. The real time figures can also be logged with XCAL and post processed for somewhat more detailed analysis. For a more detailed analysis MAC TTI-traces should be taken from the eNodeB. These logs give very detailed information of how the air interface is performing and if there are abnormalities in the functionality. Internal R&D logs that are collected within the eNodeB can also be examined for further analysis. The details of how the KPI measurements can be performed with these tools will be discussed further in Chapter 5.3.

5.2.2 Test configurations and parameters

At this point it should be noted that before configuring any I-RAT handover related parameters, the parameters for idle mode mobility should be optimized. This is because handovers consume significant amounts of signaling capacity and thus unnecessary handovers should be avoided. Therefore it would be beneficial if a UE that is moving from idle mode to RRC connected mode was already camping in the cell with the best radio conditions and a handover would not be required right after attaching to the network. Parameters for idle mode mobility are as discussed in Chapter 3, similar to those of connected mode mobility. These include parameters such as neighboring cell configurations, frequency/RAT prioritization and mobility triggering thresholds.

For connected mode mobility, the neighboring cell relationships and RAT prioritization are configured as already mentioned in the test environment plan. The exact values for these configuration parameters will not be provided here since optimization of these parameters is anyway expected to be done more or less with a trial and error based method, which will be possible only after I-RAT handovers from LTE to 3G can actually be executed. Basically neighboring cell configurations and their carrier frequencies, A2 handover trigger values as well as RSRP values for starting inter-RAT measurements, and then RAT prioritization are the necessary parameters that need to be defined in the source eNodeB and the target RNC. The core elements, i.e. SGSN and S-GW naturally need to be configured for interworking so that for example correct routing and subscriber profiles are defined from both ends. The details of core network element configurations are however well beyond the scope of this document. The UE then needs to be configured to operate in both LTE and 3G modes of operation.

Separate test cases should be performed for different traffic models since they can have an effect on the network performance. In general testing should also be differentiated to tests with stationary UEs and then tests with mobile UEs. However in this case since handovers are being tested, we can assume only mobile UE cases. Also different QoS-classes should be tried out so that the QCI mapping between RATs can be verified and the impact of various user data throughputs to handover performance can be investigated. At least the following traffic models should be tested for individual KPI results.

- Downlink TCP single UE/multiple UEs
- Uplink TCP single UE/multiple UEs

- Downlink UDP single UE/multiple UEs
- Uplink UDP single UE/multiple UEs

XCAL provides ready scripts for downloading or uploading both TCP and UDP data from a remote server. The server then resides outside of the LTE network, e.g. in a lab network, so that it interconnects with P-GW via the SGi interface. The procedures for the KPI measurements will be discussed next in the following chapter. At this point it is expected that interworking procedures are correctly configured and the parameters are optimized to some extent.

5.3 KPI measurements for I-RAT handovers

5.3.1 Handover Success rate

Handover success rate is a KPI that is a simple and straightforward indicator of handover performance in the test network. The test procedure is simple: a test car drives towards the edge of the LTE network coverage where 3G radio conditions still remain good so that an I-RAT handover is triggered, i.e. as presented in the test plan. Handovers can then fail due to protocol errors, radio link layer failures etc. The definition of handover failure is in general that a handover is considered to be failed if a handover command is sent to the UE but a handover complete message is never received. Depending on the failure reason, it may be that the connection can be re-established so that the user service remains active after a short service interruption. The worst case scenario is that the service is disconnected and a new connection needs to be established. Handover success rate KPI does not differentiate between the handover failure reasons or tell if the service is interrupted or not. Therefore it can be used merely as an overall indicator of handover performance. A more detailed analysis based on core network signaling messages or eNodeB air interface TTI-traces may be necessary to actually isolate the reason for a handover failure. The target for this KPI is that the handover success rate is above 98%.

The KPI for handover success rate is calculated by the received messages as seen by the source eNodeB, according to formula 1.

$$\text{Handover success rate} = \frac{\text{number handover confirms}}{\text{number of handover requests}} * 100\% \quad (1)$$

At the time of writing, there may not be readily available counters for inter-RAT handover success rate. These counters can however be implemented rather easily. In the first phase of

I-RAT handover testing, the calculation of handover success rate may have to be done manually. This means that the successful handover are calculated one by one, i.e. by counting the correct sets of handover signaling flows and dividing them by the total amount of handover attempts. This measurement procedure can be performed with for example the XCAL-tool. It may even be beneficial for a test engineer to be physically present in the car that drives to the handover location to analyze the environment from a radio conditions perspective and see if there is something that can be done to improve the performance. For example it can be found that turning or tilting the transmission antennas according to the landscape would be beneficial in order to physically move the handover location.

Handover failures can be detected from the signaling message flow that is captured using XCAL. In case there are no counters implemented to the base station for handover failures, handover success rate needs to be calculated manually from the signaling flow. Figure 20 illustrates a signaling message capture that contains both a successful handover and an unsuccessful handover flows. This figure illustrates merely intra-LTE handover and thus can be only used as background information. It should not however be difficult to differentiate between a successful and an unsuccessful I-RAT handover once the test engineer has seen the message signaling flows a couple of times.

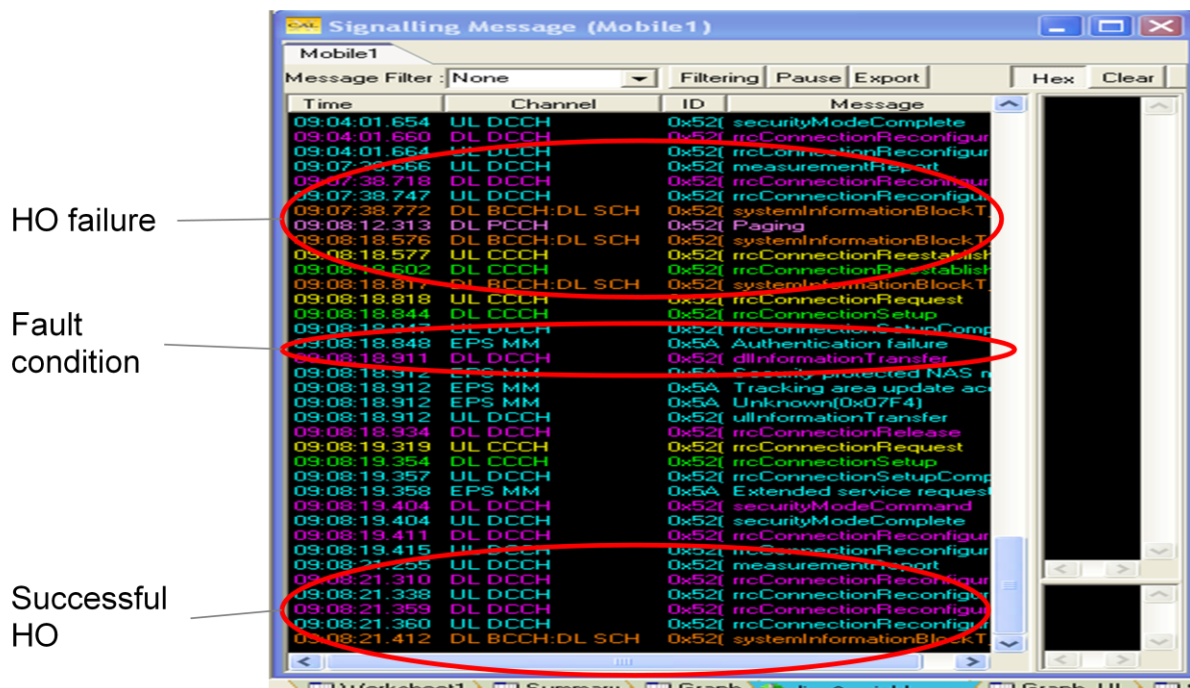

Figure 20: XCAL captured signaling flows for successful and unsuccessful intra-LTE handover scenarios

In the highlighted area at the top of Figure 20 there is only one 'rrcConnectionReconfiguration' message and one acknowledgement after the measurement report even though as mentioned in Chapter 4.2.2, there should be two of these message pairs.

After these messages there is a paging message and then a connection re-establishment request. This means that the behavior is not as specified and the handover has failed at some point of the handover procedure. This particular figure also shows an authentication failure message, which is also not the right behavior for a known UE that should have no access limitations to the network. This fault condition has already been corrected at the time of writing. Finally at the bottom of the figure there is a signaling flow of a successful handover.

5.3.2 Call Drop rate

Call drops that result in an interruption to the radio connection can occur anywhere within the radio access network. The most probable location is however at the cell edge before or right after a handover should take place. This makes it a KPI that should be monitored even though it measures also the drops that are not handover related. From the user perspective there may not be any relevance if the user service is interrupted due to a call drop or a handover failure but from a fault management perspective it is interesting to make a distinction between these two. The call can be re-established similarly as in the handover failure case so that there might be merely a small service interruption time after which the service is continued. Call drop rate is however a different KPI and call drops should be differentiated from handover failures. An example of a handover related call drop would be that the radio conditions get quickly too bad for a radio transmission and consequentially a measurement report is not heard by the base station or a handover command message is lost. Call drop rate KPI can be calculated according to formula 2.

$$\text{Call drop rate} = \frac{\text{number dropped calls}}{\text{number of successful calls}} * 100\% \quad (2)$$

Call drops can be monitored similarly from XCAL signaling messages as in the handover success rate case. Call drops are relatively easy to notice from the signaling flow as there is no handover command and a new connection request is sent. In the initial phase of I-RAT handover testing it would probably be useful for a test engineer to be physically present in the test car so that call drop locations and possible reasons could be found. One of the major reasons causing call drops is that the handover related parameters are not optimized for the given network. The RSRP value for triggering an A2 coverage handover could be too low so that in a heavily fading location the call is easily dropped before a handover takes place. The configured I-RAT measurement gap is also an interesting research subject that should be considered as a factor that has an impact on call drop rate.

Parameter optimization is a key factor to reducing call drop rate. Later on when the handover parameters are somewhat optimized, it may be enough to monitor call drop rate KPI from the counters implemented in the base stations. Then if there are significant changes to the KPI results after an eNodeB software upgrade for instance, further analysis based on TTI-traces should be performed. The target for call drop rate KPI value is usually set to be satisfied if the call drop rate is below 2%.

5.3.3 Cell throughput

Throughput is another Key Performance Indicator that should be monitored in handover cases. It is easy to measure with given software, e.g. XCAL, NetPerSec etc. and it gives an overall indication of the network performance before and after the handover. As already mentioned, such as fault case has been found in intra-LTE testing that throughput is permanently degraded after a handover. In I-RAT handover case it is also relevant to verify that the QCI-class mapping has been successful and the throughput is remains at the level specified by the provided QoS-class.

Throughput can be measured both in uplink and in downlink with a single UE or with several UEs, in which case cell throughput is the sum of the individual UE throughputs. The prerequisite for measuring the cell throughput is that all the IP-transport links have higher bandwidth capabilities than the eNodeB so that there are no bottleneck links between the IP-service and the UE, other than the air interface. It is also relevant to comprehend that cell edge throughput is considerably lower due to poor radio conditions than the maximum cell capacity. After the handover the radio conditions, and thus the throughputs are likely to start improving as the test car drives closer to the cell centre and a higher MCS level can be utilized. Cell throughput in megabits per second can be calculated using formula 3.

$$\text{Cell throughput UL/DL [Mbit/s]} = \frac{\text{transferred data volume UL/DL[bytes]}*8}{\text{transfer time [s]}*10^6} \quad (3)$$

The throughput measured from the UE side goes to zero during the handover break. Therefore a rough estimate of user plane handover delay can be obtained from the throughput graph. After a handover service interruption, the throughput starts gradually increasing according to improving radio conditions that limit the transmission capacity as well as the used traffic model. TCP traffic throughput for example increases more slowly than UDP traffic because of the slow start procedure used in many TCP algorithms. In general it should be monitored that it does not take longer than usual for the throughput to increase to a

satisfactory level. Further throughput related analysis can then be done with TTI-traces to determine if a possible fault condition is related to MAC-layer functionality or with Wireshark to analyze IP- and TCP-layer functionalities. Another interesting research subject is the impact of the scheduled I-RAT measurement break to user data throughput. Some throughput degradation can be expected but then again call drop rate may be decreased as a tradeoff. For cell throughput there are no defined target values in handover cases.

5.3.4 Handover delay

The last KPI to be introduced in this thesis is ‘Handover delay’. Measuring handover delay is somewhat more difficult than the other previously introduced KPIs. At this point it would be beneficial if the reader had some background knowledge of intra-LTE handover delay measurements before considering the more complex procedure of inter-RAT handover delay measurements. A good reference for intra-LTE handover delay measurements can be found in [40].

A considerable challenge in handover delay measurement procedure is that the target and source base stations may not be in perfect synchronization. Therefore measuring the delay from the network side does not provide reliable results. For this reason there are also no ready base station counters to monitor this KPI automatically. Neither is there any R&D functionality for reporting the delay in the commercial UEs currently used for testing. Handover delay measurements should be performed for the most part manually, and from the UE side. There are three different values to be measured under this one KPI that are listed below. First, let us discuss in detail about handover delay on UE control plane.

- *Handover delay on UE control plane* is measured from the UE side signaling messages.
- *Handover delay on UE user plane* is measured from the received IP data packets before and after the handover.
- *Handover delay on network plane* is measured from the network side.

Most of the handover complexity lies on the network side and the UE is unaware of the network side processes and signaling procedures between the two RATs. UE control plane delay is however defined as the time difference between the UE received handover command and the UE sent handover confirm. Both of these messages are visible to the UE and therefore this measurement can be performed simply by looking at the timestamps of these

two messages on the UE side with XCAL, as already discussed already in Chapter 4.2.2. The formula for UE control plane handover delay is given below in formula 4.

$$\text{Handover Delay (UE control plane)}[\text{ms}] = t_{HO \text{ Confirm}} - t_{HO \text{ command}} \quad (4)$$

User plane delay is an important metric; since it indicates how long a given the user service is interrupted. For example a voice call needs somewhat stringent requirements for a satisfactory service quality. The user would get frustrated if there were pauses that last for several seconds at a time during handovers. User plane interruption in inter-RAT handover case is illustrated below in Figure 21.

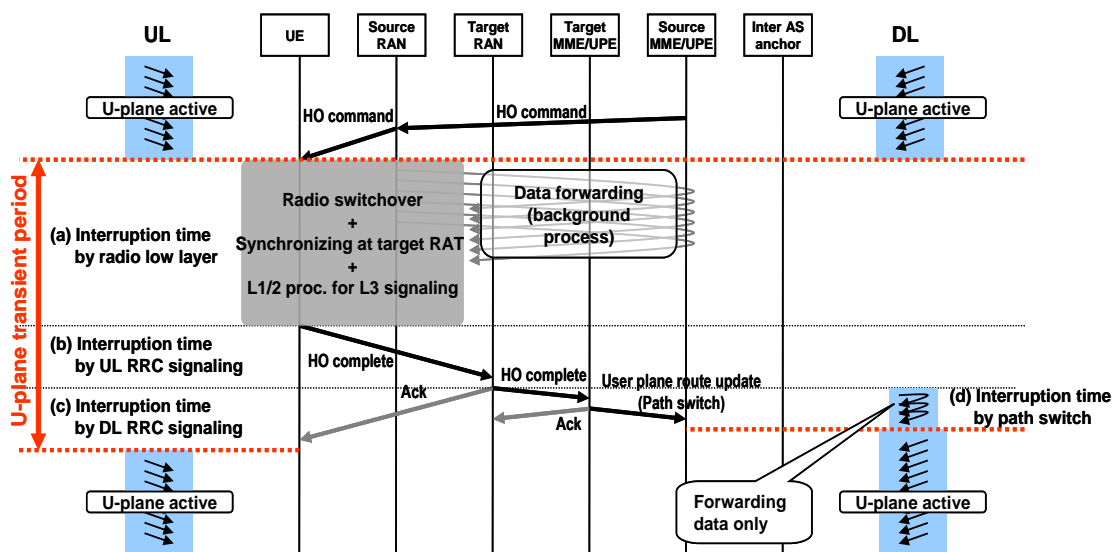

Figure 21: Analysis on the u-plane transient period [42]

The starting point of user plane delay measurement is the received handover command as illustrated in the figure above. In this model, steps (a), (b) and (c) represent the handover execution phase and step (d) the handover completion phase. Therefore the total interruption time in UL is the sum (a) + (b) + (c). The interruption time in DL is then (a) + (b) + (d). However in case the forwarded packets are available in the target RAN the interruption time in DL is (a) + (b). The assumed interruption times are specified in Table 5.

Table 5: Assumptions for LTE-3G handover interruption time [42]

	Category	Cause	Assumed time [ms]	
			2G/3G->LTE	LTE->2G/3G
(a)	Radio Low Layer process	-Radio switch over -Synchronizing at target RAT -L1/L2 process for L3 signaling	60	
(b)	UL RRC signaling	-RRC Transmission time and delay -RRC processing time	5	100
(c)	DL RRC signaling	-RRC Transmission time and delay -RRC processing time	5	100
(d)	Path switch process	-Message transmission time and delay -Path switch processing time -Packet transmission time and delay	14	

An interesting notion is that the delay expectation for handovers towards LTE is significantly lower than handovers from LTE to legacy networks. This is because of the short round trip times that LTE networks provide. Here we are however interested in the assumed interruption times of handovers from LTE to 3G. We can assume that data forwarding capability is available and there is enough time to forward the packets during the interruption time. Therefore the assumed interruption time for user plane delay is as follows.

- Interruption time for Inter-RAT HO from LTE to 3G (uplink).....260ms
- Interruption time for Inter-RAT HO from LTE to 3G (downlink).....160ms

The assumptions in Table 5 make no distinction of the used traffic type. On the control plane, it should not make a difference if the user data is real-time or non real-time type of traffic. Therefore the measurements should give similar results for both UDP and TCP traffic. As can be seen from the results presented in [40], there is a considerable difference in handover delays on the user plane for UDP traffic and for TCP traffic. The source used for the assumed figures, 3GPP document TR R.3018, merely points out that the most stringent requirement is 300ms for real-time data, which according to these assumptions should be satisfied. The issue of traffic type implications to handover delay is not addressed further in this document.

Retransmissions occur in several different layers i.e. HARQ, ARQ and TCP. Application layer may also have mechanisms for retransmission, which however are not considered as part of the interruption time. Handover delay is dependent on these retransmissions mechanisms and the in sequence delivery algorithms within the protocols. A rough separation is that UDP is non-real time type of traffic that utilizes no retransmissions on any of the layers. TCP then is real time type of traffic and utilizes unacknowledged or acknowledged RRC mode of operation. There may also be different scheduling priorities for these traffic types. The delay calculations should then assume a 10% block error ratio, which results to a few retransmissions during the handover procedure. The estimated scheduling delay should also be considered. The impact of TCP procedures to handover delay as well as throughput are discussed further in [43]. According to 3GPP standard that specifies the requirement set for LTE performance, TR 25.913 [16], both the requirement for real time and non-real time type of traffic should be achieved. Naturally this is something that needs to be verified in the test phase. The target set by the vendors is expected to be somewhat lower than the 3GPP requirement.

Regardless of the used traffic type, the formula for calculating user interruption time remains the same. Handover delay on user plane can be calculated from the time difference of the first packet received from the target RAN and the last packet received from the serving RAN, according to formula 5. The measurement can be performed with Wireshark from the timestamps of UE captured data packets. Delay variation could also be an interesting metric in user plane handover delay at least in the TCP case.

$$\text{Handover Delay (UE user plane)}[ms] = t_{\text{first packet TNB}} - t_{\text{last packet SeNB}} \quad (5)$$

Finally there is the metric for handover delay on network plane. This is an interesting metric from R&D perspective since it indicates also the performance of the handover preparation phase. Network plane delay is defined as the time difference between the received measurement report at serving eNodeB and the sent UE context release complete message to MME, according to formula 6.

$$\text{Handover Delay (Network plane)}[ms] = t_{\text{UE Context release complete SeNB}} - t_{\text{Measurement report SeNB}} \quad (6)$$

This value indicates the overall delay of the handover procedure. It is therefore longer than the user interruption time since user data is still running as usual to the serving eNodeB in the handover preparation phase.

5.3.5 Summary of KPI measurements and considerations for test automation

Test automation has come a long way in LTE functionality and performance testing. Not too long ago there were no ready KPI counters implemented in the base station. Performance figures were for the most part calculated manually and the KPIs roughly estimated from these figures. For example handover success rate used to be measured by monitoring the signaling scenarios of 10 UEs simultaneously and manually marking down the amount of successful handovers. This often required 3 test engineers to sit in the car and monitor 10 laptops in total at the time since each UE required a laptop of its own and no call generators were available. Even the test cases had to be manually configured to each of the test laptops. Today all of this can be done with a single device, which can be remotely controlled with a reliable wireless connection. The KPIs then can be read from the base station counters and a spreadsheet- or a power point report that contains graphical representations of the measurement data can be created with an automated tool.

Automated tools have made test execution and the provision of KPIs faster and easier. The goal of test measurements is however not to just provide endless amount of KPI reports. The

main goal is to locate and isolate the faults and the deficiencies within the LTE network software and hardware. KPIs are however good for indicating the existence of a fault conditions in a particular area of the network functionality. With easier test execution and automatic KPI provision, the faults can be more easily located and the test engineers can focus on analyzing the test results in depth and hopefully isolate the fault conditions and the causes behind them.

Inter Radio Access Technology handover testing will be for the most part manual in the initial tests, since no ready KPI counters are expected to be available. The direction should then be towards more automation and simplified processes. Developing highly automated test procedures is however not self evident. This is because automation development can be costly and it should be considered if the benefits of the developed automation processes actually exceed the costs. Coordination between the test teams is important since I-RAT handover testing has an effect on both the target and source radio access technology. I-RAT handover test processes need to be agreed with the test teams and test engineers need to be well informed of the processes so that the testing can be performed efficiently while avoiding any confusions or complications.

After initial testing, network optimization and the implementation of automation to some degree, several challenges remain in I-RAT handover testing. Currently there is usually only one car with 10UEs driving through the test network and there are no stationary UEs located within the network area. This means that in the field, handovers occur towards unloaded cells. Adding stationary UEs and increasing the amount of UEs within the car should be considered so that the test conditions would come closer to those of real live networks. The presented plan for test measurement procedures and tools for the testing I-RAT handover is however merely an initial test plan and it needs to be revised after the initial test results. It may even be that more KPIs need to be added to the set. However the test plan presented in this chapter should provide the basic tools and methods that can be used in I-RAT handover performance measurements. The planned measurement KPIs and the measurement tools are summarized in Table 6.

Table 6: Planned measurement KPIs and measurement tools

KPI name	description	measurement tools	target
Handover success rate	Gives an overall indication of handover performance	XCAL signaling figures, base station counters	>98%
Call drop rate	Indicates if the calls are being dropped before or after the handover due to poor radio conditions	Signaling figures, counters	<2%
Throughput	User throughput before and after the handover	XCAL, NetPerSec	N/A
Handover delay	U-plane C-plane and network plane handover interruption time	Wireshark	<300ms for RT traffic, <500ms for NRT traffic

6. CONCLUSIONS AND FUTURE WORK

This chapter summarizes the main topics and results presented in this thesis. The contents of this chapter are as follows. Chapter 6.1 summarizes the most important points in the five first Chapters of the thesis while emphasizing on the key ideas and findings of the research work. Chapter 6.2 then provides ideas for future work related to I-RAT handover testing as well as LTE radio access technology feature and functionality testing in general. Finally, considerations of future radio access technologies such as LTE-Advanced are addressed.

6.1 Conclusions

LTE is a fourth generation mobile network technology that provides impressive service capabilities such as high data rates, cost efficient operation and ‘anywhere anytime’ type of service provisioning. There are already several commercial LTE networks in customer use and a handful of operators have already made plans of launching LTE networks of their own. The rollout of new LTE radio access networks is however expected to be initially based on service hot spots in some major cities. Legacy cellular systems will also be there to serve the users for years to come. To provide seamless and uninterrupted user service, mobility across radio access technologies is required. This feature yields great value to the operators and therefore the implementation, including functional testing of I-RAT handovers, especially towards legacy 3G networks, is a high priority item on the vendor side.

The presented test plan utilizes the existing test network and specifies the handover locations and the involved base stations. With the performed radio condition measurements in the handover points, it can be concluded that the presented locations should provide a solid test bed for inter radio access technology handovers. The configuration is permanent from the network side while the UEs can be configured to I-RAT mode or single mode based on the testing needs. The configuration is relatively simple. Besides the neighbouring cell configurations, only A2 coverage handover triggers and RAT prioritization parameters need to be defined. The necessary KPI measurements then can be performed with existing tools such as Wireshark, XCAL and TTI-trace analyzer.

The testing is expected to be manual in the beginning but the direction should be towards more automated test processes. Minor modifications to the plan may be needed during the test execution phase but initially this plan should be comprehensive enough for testing and developing this feature so that once the implementation is ready for testing, Inter Radio

Access Technology handover feature can be delivered to the operators with both quality and haste.

6.2 Future work

System verification and performance testing is a continuous process. As new software and hardware are implemented to the LTE network, not only are the new features tested but also the existing features and functionalities need to be verified. Legacy 3G networks and even 2G networks are still being developed and new features are implemented and then verified and tested even today. It can be expected that the development of LTE technology will continue for years to come. At the moment the important areas of work are in test automation and adding the test complexity in such a way that there are more UEs both in the test car and stationary UEs scattered within the network area.

Related to I-RAT mobility there are also lots of areas for future work. One interesting topic is the implementation of voice services to LTE. Circuit Switched Fall Back, which utilizes the legacy cellular networks, will most likely be the first feature to voice service provisioning to multimode capable LTE devices. When VoIP calls are available in LTE networks, Single Radio Voice Call Continuity, which is an I-RAT handover of an existing voice call to legacy cellular networks, and its performance, becomes an important issue. Scenarios for mobility from LTE to 3G/2G CS networks are discussed further in [44]. Mobility features for I-RAT handovers from LTE to 2G as well as inter-technology mobility towards non-3GPP technologies such as WiMaX and WLAN will then remain challenging new research items.

In the field of cellular radio access networks, e.g. in the future 3GPP releases there are lots of ongoing research work. After the currently developed LTE release 8, the development work will continue in LTE release 9, which introduces i.e. enhanced SON features. Even more interesting will be 3GPP release 10. This release, called LTE-Advanced provides data rates of up to gigabits per second [45]. This performance can be achieved with enhanced MIMO techniques of up to 8 transmission antennas in downlink and 4 antennas in uplink. Cells with transmission bandwidth of up to 100MHz can be deployed by aggregating up to 5 LTE release 8 specified 20MHz bandwidths. New challenges can be expected as yet another radio access technology with increased performance demands to the terminal- and the test equipment as well as increased interworking requirements is developed.

REFERENCES

- [1] H. Holma, A. Toskala, LTE for UMTS – OFDMA and SC-FDMA Based Radio Access, John Wiley & Sons, 2009
- [2] Third Generation Partnership Project, 3GPP description and roles, available at <http://www.etsi.org/WebSite/AboutETSI/GlobalRole/3GPP.aspx>
- [3] Nokia Siemens Networks press release, TeliaSonera's 4G services now live in Gothenburg, August 2010, available at <http://www.nokiasiemensnetworks.com/news-events/press-room/press-releases/teliasonera-s-4g-services-now-live-in-gothenburg>
- [4] LTE Inter-technology Mobility: Enabling Mobility Between LTE and Other Access Technologies, Motorola white paper, November 2008
- [5] M. Olsson, S. Sultana, et. Al, SAE and the Evolved Packet Core: Driving The Mobile Broadband Revolution, First edition, Elsevier Ltd., 2009
- [6] K. Dimou, M. Wang et al, Handover within 3GPP LTE: Design Principles and Performance, Ericsson Research, 2009
- [7] Mohammed, A., H. Kamal, et al, 2G/3G INTER-RAT HANDOVER PERFORMANCE ANALYSIS, February 2008
- [8] K. Pothireddy, I-RAT Testing (2G to 3G Handover Testing), available at <http://www.docstoc.com/docs/29174453/IRAT-Testing>
- [9] 3GPP TS 36.300 V8.4.0, Evolved Universal Terrestrial Radio Access (E-UTRA) and Evolved Universal Terrestrial Radio Access Network; Overall description, March 2008
- [10] 3GPP TR 25.912 V8.0.0, Feasibility study for evolved Universal Terrestrial Radio Access (UTRA) and Universal Terrestrial Radio Access Network (UTRAN), December 2008
- [11] LTE – an introduction, Ericsson whitepaper, June 2009
- [12] ITU press release, “ITU World Radiocommunication Seminar highlights future communication technologies”, December 2010, available at http://www.itu.int/net/pressoffice/press_releases/2010/48.aspx
- [13] S. Parkvall, 3G Evolution – HSPA and LTE for Mobile Broadband, Ericsson research, February 2008
- [14] LTE Flat Rate Pricing for Competitive Advantage, Motorola white paper, 2009
- [15] 3G LTE Tutorial - 3GPP Long Term Evolution, available at <http://www.radio-electronics.com/info/cellulartelecomms/lte-long-term-evolution/3g-lte-basics.php>

- [16] 3GPP TR 25.913 V9.0.0, Requirements for Evolved UTRA (E-UTRA) and Evolved UTRAN (E-UTRAN), December 2009
- [17] 3GPP TS 23.401 V8.12.0, General Packet Radio Service (GPRS) enhancements for Evolved Universal Terrestrial Radio Access Network (E-UTRAN) access, December 2010
- [18] Long Term Evolution (LTE): A Technical Overview, Motorola white paper, 2007
- [19] LTE RAN System Description, Nokia Siemens Networks LTE Radio Access Operating Documentation, October 2010
- [20] M. Rumney, J. Whitacre, et. Al, LTE and the evolution to 4G Wireless – Design and measurement Challenges, Agilent technologies Publication, 2009
- [21] 3GPP TS 36.213 V8.8.0, Evolved Universal Terrestrial Radio Access (E-UTRA); Physical layer procedures, September 2009
- [22] H. Schulze, C. Luders, Theory and Applications for OFDMA and CDMA, Wiley 2005
- [23] H. Myung, D. Goodman, Single Carrier FDMA: A New Air Interface for Long Term Evolution, Wiley 2008
- [24] 3GPP TR 25.813 V7.1.0, Radio interface protocol aspects, September 2006
- [25] 3GPP TS 36.201 V8.3.0, LTE Physical Layer - General Description, March 2009
- [26] 3GPP TR 25.814 V7.1.0, Physical layer aspects for evolved Universal Terrestrial Radio Access (UTRA), September 2006
- [27] 3GPP TS 36.321 V8.9.0, Evolved Universal Terrestrial Radio Access (E-UTRA); Medium Access Control (MAC) protocol specification, June 2010
- [28] 3GPP TS 36.322 V8.8.0, Evolved Universal Terrestrial Radio Access (E-UTRA); Radio Link Control (RLC) protocol specification, June 2010
- [29] 3GPP TS 36.323 V8.6.0, Evolved Universal Terrestrial Radio Access (E-UTRA); Packet Data Convergence Protocol (PDCP) specification, June 2009
- [30] S. Addepalli, LTE PDCP from eNodeB perspective, June 2010, available at <http://netsecinfo.blogspot.com/2010/06/lte-pdcp-description.html>
- [31] 3GPP TS 36.331 V8.12.0, Evolved Universal Terrestrial Radio Access (E-UTRA); Radio Resource Control (RRC); Protocol specification, December 2010
- [32] S. Sesia, I. Toufik, M. Baker, LTE - The UMTS Long Term Evolution From theory to practise, John Wiley & Sons, First edition, 2009
- [33] Self Organizing Network “NEC's proposals for next-generation radio network management”, NEC Corporation Technical white paper, February 2009

- [34] 3G and 4G Wireless Blog: Black-listed and White-listed cells in E-UTRAN, April 2009, available at <http://3g4g.blogspot.com/2009/04/black-listed-and-white-listed-cells-in.html>
- [35] ITU-T Recommendation G.1010, End-user multimedia QoS categories, November 2001
- [36] C. Crow, Mobility over LTE/SAE, available at <http://www.imacandi.net/windancer/2010/03/10/mobility-over-ltesae.html>
- [37] H. Holma, A. Toskala, WCDMA for UMTS: HSPA Evolution and LTE, fifth edition, John Wiley& Sons, 2010
- [38] TTI Trace LTE MAC SW, NSN internal document, 2008
- [39] Accuver test tool brochure, available at http://www.inala.co.za/brochures/accuver/accuver_brochure.pdf
- [40] L. Bhebhe, J. Vehanen, Inter-eNB Handover performance via X2, NSN research, February 2011
- [41] P. Medd, LTE: Next-Generation Test Challenges, Aeroflex Test Solutions white paper, October 2009
- [42] 3GPP TR R3.018 V1.0.0, Evolved UTRA and UTRAN; Radio Access Architecture and Interfaces, October 2007
- [43] A. Racz, et. Al, Handover Performance in 3GPP Long Term Evolution (LTE) Systems, Ericsson research, August 2007
- [44] 3GPP TR 23.882 V8.0.0, 3GPP System Architecture Evolution: Report on Technical Options and Conclusions, September 2008
- [45] Strategies for IMT-Advanced:3GPP Perspective, 3GPP, 2 June 2010
- [46] S. Logghe, S. Maerivoet, Validation of travel times based on Cellular Floating Vehicle Data (CFVD), Paper & poster at the 6th European Congress and Exhibition on Intelligent Transport Systems and Services (ITS), Aalborg, Denmark, June 2007, available at <http://www.tmleuven.be/project/cfvd/home.htm>

APPENDIX A – Example of user mobility case in a cellular network

A mobile user can move within a cellular network of eNodeBs as illustrated in Figure 22. In this case let us assume that an LTE network of 8 cells is deployed as an initial hot spot rollout in a given location. For simplicity, the eNodeBs are located in the middle of the rectangular coverage area and intra-eNodeB handovers are ignored. The user traverses the network in RRC Connected mode and is being handed over to neighbouring cells as her or she crosses over the cell boundaries. In practice he or she reaches a point where the radio conditions are a given threshold better for the neighbouring cell than the radio conditions in the serving cell. Let us further assume that he or she moves out of the coverage area of the LTE network. As WCDMA is widely deployed, it is likely that there is 3G coverage beyond this point. In this case a seamless I-RAT handover is performed. This means that the user services remain active and there is an unnoticeable interruption time in between the change of radio access technologies.

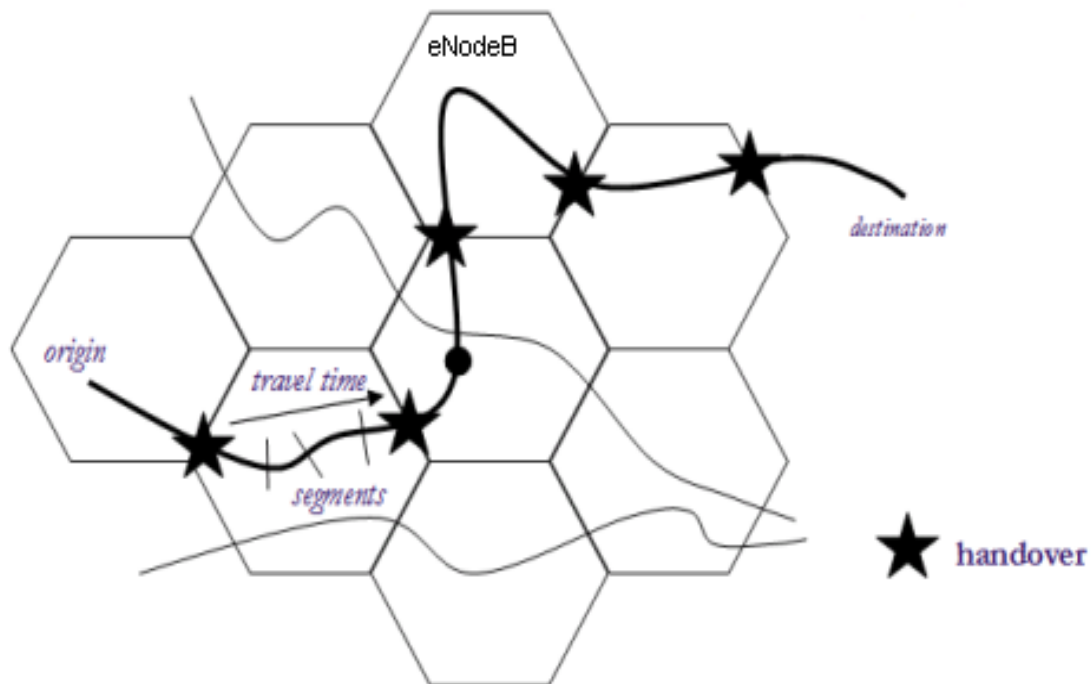

Figure 22: User active mode mobility in a cellular network [46]

Appendix B – Intra-LTE, Inter-eNodeB handover signalling without MME/S-GW relocation

Handover signalling in intra-LTE, inter-eNodeB without MME/SGW relocation is illustrated below in Figure 23. The handover phases as explained in Chapter 3.2.3 can be found from the right hand side of the figure. The signalling messages between the network elements related to each phase are then illustrated on the left hand side. It should be noted that measurement control is not included in the preparation phase in this figure. The details of the signalling messages are specified by 3GPP in [9].

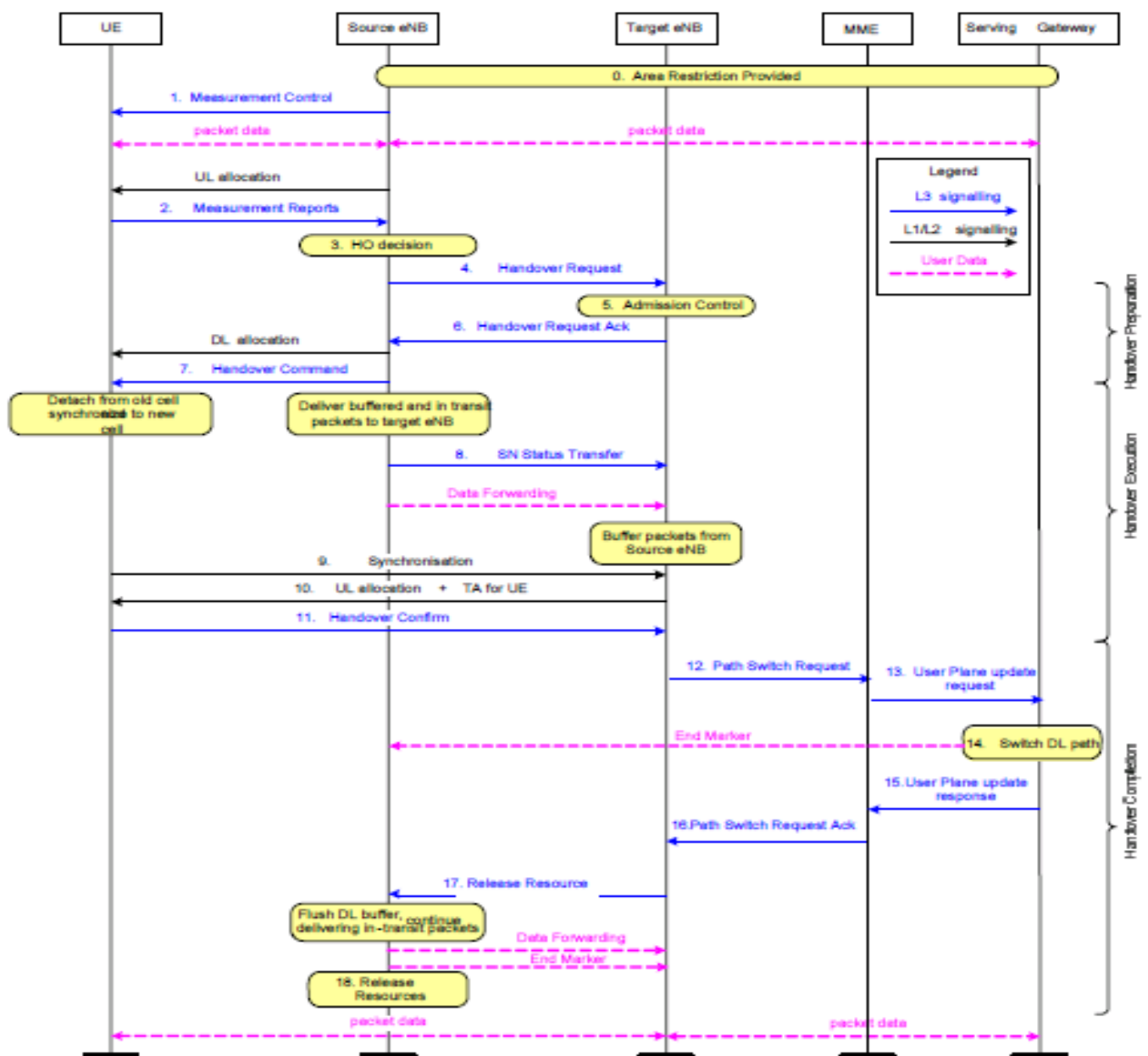

Figure 23: Inter eNB Handover signaling [9]

Appendix C – Handover delay measurement procedure with Wireshark-tool

One relatively simple method for measuring handover delay is based on capturing user data on the UE side with Wireshark. Handover delay can be calculated from the difference between the timestamps of two consecutive packets that are received from different base stations. With the high data rates provided by LTE, the amount of packets is high and thus locating the packets of interest from the capture is time consuming. Therefore it is useful to utilize a graphical tool that illustrates user throughput, and use the figure to locate the handover point. This procedure is illustrated below in Figure 24. This particular figure is a measurement for user plane traffic break in X2 based inter-eNodeB handover with downlink UDP traffic. The details and further analysis of this test can be found in [40]. Measuring the delay from eNodeB side does not provide reliable results since the clocks in different base stations may not be perfectly synchronized.

In this example IP-layer break can be calculated from the timestamps as follows: $240.13ms - 171.754 ms = 68.376 ms$ (only the millisecond part of the timestamp is considered).

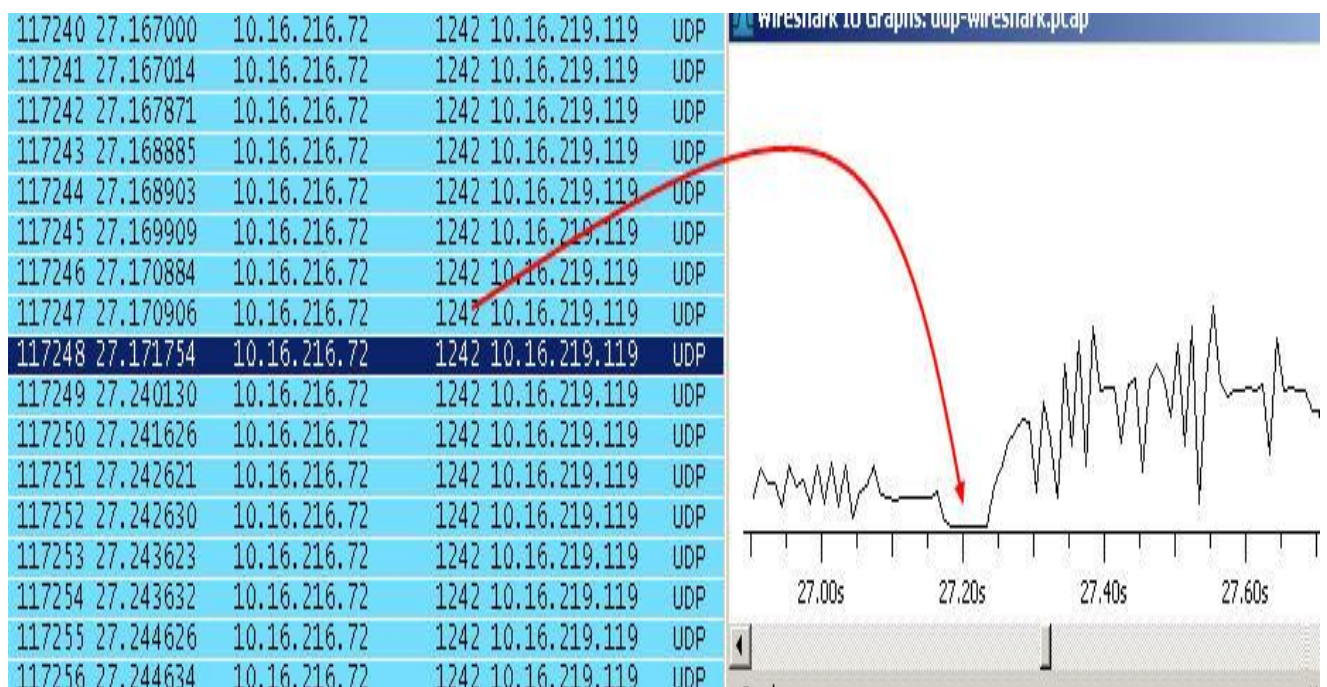

Figure 24: Wireshark packet capture from UE side highlighting measured intra-LTE X2 based handover interruption time [40]

Appendix D – Initial measurement for I-HSPA radio conditions in handover point C

Figure 25 below illustrates a drive test that was run to measure the radio conditions for Vänrikki I-HSPA cell. The goal was to determine if the radio conditions of the I-HSPA cell were sufficient to sustain an incoming I-RAT handover in handover point C as discussed in Chapter 5.1.2. The two similar figures illustrate the two important radio condition metrics for 3G cells that are RCSP on the left and Ec/Io on the right hand side of the figure. The test was done by driving with one UE that was in active mode and recording the radio conditions with the Nemo-tool. Handover point C is approximately in the middle of the hill that can be seen from the map.

The result of the test is as follows. RCSP values were varying between around -90dBm and -100dBm, while Ec/Io values were between around -6dB to -9dB. These metrics indicate relatively good radio conditions and therefore it can be determined that the radio conditions are good enough for an incoming I-RAT handover. LTE radio condition measurements were then performed with an XCAL. The results were that RSRP will drop below -120dBm at handover point C and this value can be set as the triggering point for an A2 coverage handover. There should also be no trouble performing the handover to other direction, to LTE with the correct triggers, parameters and prioritization of LTE. Similar measurements were done for Sello WCDMA 3G cells.

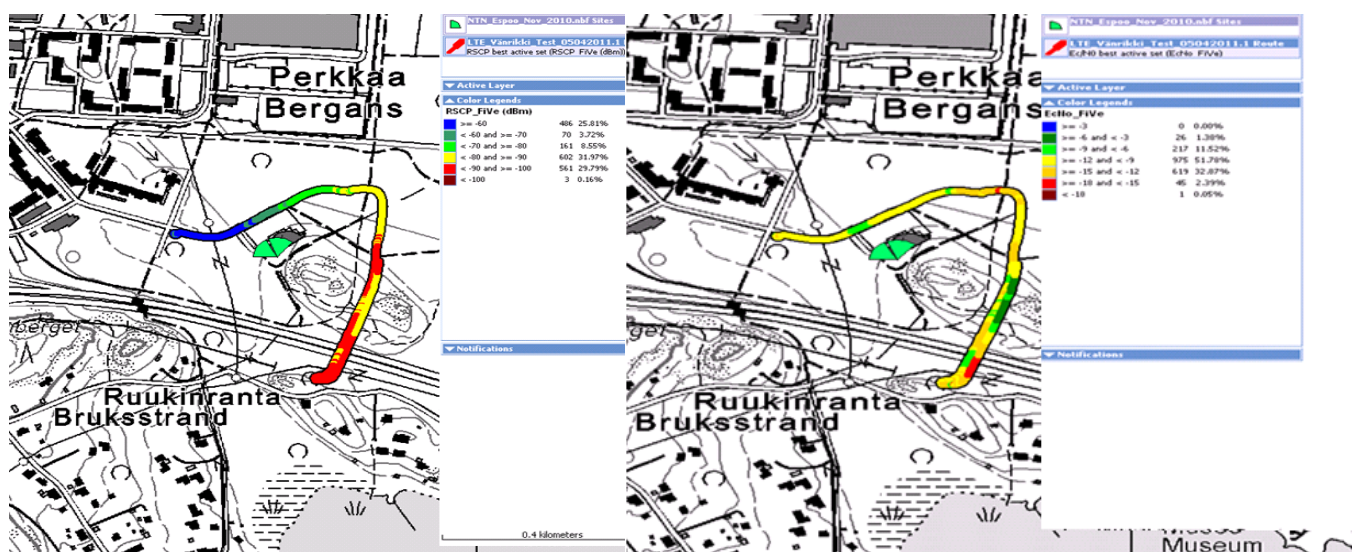

Figure 25: I-HSPA radio condition measurement with Nemo-tool in handover point C