

Helsinki University of Technology
Department of Engineering Physics and Mathematics

NEUROMAGNETIC CHARACTERIZATION OF THE HUMAN SECONDARY SOMATOSENSORY CORTEX

Cristina Simões

Brain Research Unit
Low Temperature Laboratory



TEKNILLINEN KORKEAKOULU
TEKNISKA HÖGSKOLAN
HELSINKI UNIVERSITY OF TECHNOLOGY

Helsinki University of Technology
Department of Engineering Physics and Mathematics

NEUROMAGNETIC CHARACTERIZATION OF THE HUMAN SECONDARY SOMATOSENSORY CORTEX

Cristina Simões

Brain Research Unit
Low Temperature Laboratory

Dissertation for the degree of Doctor of Philosophy to be presented with due permission for public examination and debate in Auditorium F1 at the Helsinki University of Technology, Espoo, Finland, on the 15th of November, at 12 o'clock noon.

Distribution:

Low Temperature Laboratory
Helsinki University of Technology

P.O.Box 2200

FIN-02015 HUT, Finland

Tel: +358-9-451 5619

Fax: +358-9-451 5619

This thesis is downloadable at <http://lib.hut.fi/Diss/list.html>

ISBN 951-22-6178-2 (printed version)
ISBN 951-22-6179 (electronic version)

Otamedia Oy
Espoo 2002

TITLE: Neuromagnetic characterization of the human secondary somatosensory cortex

AUTHOR: Cristina Simões
Brain Research Unit
Low Temperature Laboratory
Helsinki University of Technology

DATE: November, 2002

ABSTRACT: This thesis aims to characterize functions of the secondary somatosensory cortex SII in humans by means of neuromagnetic recordings. It starts with a review of literature about methodological considerations concerning the generation of neuromagnetic fields and how they can be measured and modeled. Then follows a brief overview of the somatosensory system, its receptors, ascending pathways, and cortical regions. The main part of the text summarizes the individual publications. Studies I and II show a strong interaction at SII between inputs of the two hands and of different fingers in the same hand, suggesting that SII plays an important role in integrating sensory information from the two body halves. Studies III and IV reveal left hemisphere-dominant SII activation for median nerve stimulation and passive movements of the index finger, suggesting hemispheric specialization for the processing of somatosensory information. Study V analyzes functional connectivity between SI and SII cortices by means of phase-locked activity. Study VI shows that SII activation is distinctly affected by contraction of different muscles. Altogether these studies provide an insight in to the role of SII in somatosensory processing.

KEYWORDS: Magnetoencephalography; human; cortex; somatosensory; SI; SII; passive movement; phase-locked activity; hemispheric dominance; muscle contraction.

ACADEMIC DISSERTATION

AUTHOR: Cristina Simões
Brain Research Unit
Low Temperature Laboratory
Helsinki University of Technology
Finland

SUPERVISOR: Academy Professor Riitta Hari
Brain Research Unit
Low Temperature Laboratory
Helsinki University of Technology
Finland

PRELIMINARY EXAMINERS: Docent Juha Huttunen
Department of Clinical Neurophysiology
Helsinki University Central Hospital
Finland

Professor Gian-Luca Romani
Institute of Advanced Biomedical Technologies
University of the Studies G. d'Annunzio, Chieti
Italy

OFFICIAL OPPONENT: Professor Eduardo Ducla-Soares
Institute of Biophysics and Medical Physics
Faculty of Sciences
University of Lisbon
Portugal

TABLE OF CONTENTS

LIST OF ORIGINAL PUBLICATIONS.....	i
CONTRIBUTIONS OF THE AUTHOR.....	i
ABBREVIATIONS.....	ii
PREFACE.....	iii
1. INTRODUCTION.....	1
2. REVIEW OF LITERATURE.....	2
2.1 MAGNETOENCEPHALOGRAPHY.....	2
Neuronal currents.....	2
Neuromagnetic fields.....	3
Instrumentation.....	4
Applications of MEG.....	6
Other functional neuroimaging techniques.....	6
2.2 SOMATOSENSORY SYSTEM.....	8
Modalities and receptors.....	8
Afferent pathways.....	8
Primary somatosensory cortex (SI).....	9
Secondary somatosensory cortex (SII).....	10
Other somatosensory areas.....	11
3. AIMS OF THE STUDY.....	12
4. MATERIALS AND METHODS.....	13
4.1 SUBJECTS.....	13
4.2 STIMULATION.....	13
Electric stimuli.....	13
Tactile stimuli.....	13
Proprioceptive stimulation.....	14
4.3 RECORDINGS.....	14
4.4 DATA ANALYSIS.....	15
Source modeling.....	15
Quantification of phase-locking.....	15
5. EXPERIMENTS.....	17
5.1 SII RESPONSES TO IPSI- AND CONTRALATERAL STIMULI (STUDY I).....	17
Results.....	17
Discussion.....	19
5.2 FUNCTIONAL OVERLAP OF FINGER REPRESENTATIONS IN SI AND SII CORTICES (STUDY II).....	21
Results.....	21
Discussion.....	22
5.3 LEFT-HEMISPHERE-DOMINANT SII ACTIVATION (STUDY III).....	23
Results.....	23
Discussion.....	24
5.4 CORTICAL ACTIVATION AFTER PASSIVE MOVEMENTS OF THE INDEX FINGER (STUDY IV).....	26
Results.....	26
Discussion.....	28
5.5 PHASE-LOCKED ACTIVITY BETWEEN SI AND SII CORTICES (STUDY V).....	29
Results.....	29
Discussion.....	31

5.6 EFFECT OF MUSCLE CONTRACTION ON SEFS (STUDY VI).....	33
Results.....	33
Discussion.....	34
6. CONCLUSIONS.....	35
REFERENCES.....	36

LIST OF ORIGINAL PUBLICATIONS

This thesis is based on the following six publications which are referred to in the text by their Roman numerals I-VI

- I **Simões C**, and Hari R. Relationship between responses to contra- and ipsilateral stimuli in the human somatosensory cortex SII. *NeuroImage* 1999, 10: 408-416.
- II **Simões C**, Mertens M, Forss N, Jousmäki V, Lütkenhöner B, and Hari R. Functional overlap of finger representations in the human SI and SII cortices. *J Neurophysiol* 2001, 86: 1661-1665.
- III **Simões C**, Alary F, Forss N, and Hari R. Left-hemisphere dominant activation after bilateral median nerve stimulation. *NeuroImage* 2002, 15: 686-690.
- IV Alary F, **Simões C**, Jousmäki V, Forss N, and Hari R. Cortical activation associated with passive movements of the human index finger: an MEG study. *NeuroImage* 2002, 15: 691-696.
- V **Simões C**, Jensen O, Parkkonen L, and Hari R. Phase-locking between human SI and SII cortices. *TKK report*, TKK-KYL-007.
- VI Lin Y, **Simões C**, Forss N, and Hari R. Differential effects of muscle contraction from various body parts on neuromagnetic somatosensory responses. *NeuroImage* 2000, 11: 334-340.

CONTRIBUTIONS OF THE AUTHOR

I was the principal author in Studies I–III and V, carrying out the measurements, analyzing the data and writing the publications with input from my co-authors.

I had a major contribution in the acquisition and analysis of the data in Studies IV and VI. In both these publications the first author was responsible for the writing of the manuscript, but I participated actively with the other co-authors.

In all studies, I also actively participated in the planning of the experiments.

ABBREVIATIONS

AEF	Auditory evoked fields
ECD	Equivalent current dipole
EEG	Electroencephalography
EOG	Electro-oculography
fMRI	Functional magnetic resonance imaging
ISI	Interstimulus interval
MEG	Magnetoencephalography
MN	Median nerve
MRI	Magnetic resonance imaging
PET	Positron emission tomography
PLV	Phase-locking value
PPC	Posterior parietal cortex
SEF	Somatosensory evoked field
SEM	Standard error of mean
SI	Primary somatosensory cortex
SII	Secondary somatosensory cortex
SNR	Signal-to-noise ratio
SQUID	Superconducting quantum interference device
TFR	Time-frequency representation
VP	Ventroposterior nucleus of the thalamus
VPI	Ventroposterior inferior nucleus of the thalamus
VPL	Ventroposterior lateral nucleus of the thalamus
VPM	Ventroposterior medial nucleus of the thalamus

PREFACE

This thesis was carried out in the Brain Research Unit of the Low Temperature Laboratory (LTL) at the Helsinki University of Technology. This work was financially supported by the Academy of Finland and the Portuguese Foundation for Science and Technology.

I want to express my sincere gratitude to my supervisor Academy Professor Riitta Hari, head of the Brain Research Unit, for her guidance, optimism and patience during my work. She is unique in combining the expertise in scientific thinking and management with a kind and warm personality. Her friendship in some difficult moments of my work and life will be always remembered.

I wish to thank the former head of the Low Temperature Laboratory, Academician Olli V. Lounasmaa, and his successor, Professor Mikko Paalanen, for the opportunity of work in this laboratory of Excellence, and for all the support during my stay at the LTL. The facilities and enthusiastic atmosphere in this place provide the opportunity for making top-research in the fields of Low Temperature Physics and Neuroscience.

I sincerely thank my co-authors Dr. Flamine Alary, Docent Nina Forss, Dr. Ole Jensen, Dr. Veikko Jousmäki, Dr. Yung-Yang Lin, Dr. Bernd Lütkenhöner, Dr. Markus Mertens and Mr. Lauri Parkkonen for fruitful discussions. The diversity of backgrounds has been very inspiring for my work.

I also thank my supervisor on behalf of the Department of Engineering Physics and Mathematics, Professor Toivo Katila, for his help and support during my studies.

I am grateful to Docent Juha Huttunen and Professor Gian-Luca Romani for careful review of my thesis and to Docent Nina Forss, Professor Riitta Hari, Academician Olli V. Lounasmaa and Mr. Topi Tanskanen for their helpful and constructive criticism on my manuscript.

I would like to express my gratitude to Professor Riitta Salmelin for her enthusiasm and friendly support during my stay at the LTL.

I owe my sincere thanks to Ms. Mia Illman for her kindness and friendship. With her I took my first small steps in the MEG recordings and data analysis.

I would like to thank the multitude of wonderful colleagues I have been fortunate to work with during my stay at the LTL: Sari Avikainen, Katri Cornelissen, Gabriel Curio, Nobuya Fujiki, Samuli Hakala, Päivi Helenius, Matti Hämäläinen, Juha Järveläinen, Jaakko Järvinen, Matti Kajola, Erika Kirveskari, Ken-ichi Kaneko, Kari Kuukka, Christian Lammertmann, Sari Levänen, Mia Liljeström, Nobuki Murayama, Karin Mårtenson, Jyrki Mäkelä, Nobuyuki Nishitani, Jussi Numminen, Ritva Paetau, Marjatta Pohja, Tommi Raij, Tuukka Raij, Hanna Renvall, Mikko Sams, Ronny Schreiber, Stephan Salenius, Teija Silén, Mika Seppä, Martin Schürmann, Samu Taulu, Claudia Tesche, Kimmo Uutela, Simo Vanni, Minna Vihla, and Tiina Vuorinen. Special thanks to my room-mates and friends Jan Kujala and Antti Tarkiainen with whom I shared my office, many of the joys and sorrows of my work, and loads of candies!

I deeply acknowledge the help and efficiency of Doc. Peter Berglund, Ms. Teija Halme, Ms. Marja Holmström, Ms. Pirjo Kinanen, Ms. Tuire Koivisto, Ms. Satu Pakarinen, and Ms. Liisi Pasanen in many practical and bureaucratic terms of my stay.

I would like to express my gratitude to all my friends inside and outside the laboratory, in Finland, in Portugal and a bit all over the world, for the wonderful times we spent together. Very special thanks to Isabel Pinto for her enormous friendship; with her I have shared sweet and sour times during my stay in Helsinki.

I am deeply grateful to my wonderful parents, brother and sister-in-law. Without their support, their care and their love this thesis would not have been possible. To them I owe, if not everything, the strength and the courage that kept me going in some moments when I just needed the comfort of my family. *Muito obrigada pelo vosso apoio incondicional!*

My warmest thank to Séadna Franklin for entering my life and completing it! It is hard to imagine how these last steps of my work would have been possible without his support and his *virtual* presence.

Finally, I would like to dedicate this thesis to my dear nephew André Simões who taught me, with his beautiful smile, what are the important things in life.

A handwritten signature in black ink. The signature consists of a large, stylized 'C' followed by 'ristina' and a large, stylized 'S' followed by 'Simões'. The name 'Cristina Simões' is written in a cursive, flowing style.

Helsinki, October 2002

1. INTRODUCTION

"The skin, which from head to foot relates us sensitively to the world in which we live, our matrix, is indeed our most consistently active and informing organ of sense. In a dark vacuum where only minimal sight, hearing, taste, smell and muscle activity would be possible, the skin could still report something of the nature of the surroundings: dry, cold, wet, hot, soft, hard, pressure. This was at one time our total awareness of the nature of the sheltering womb."

(Erikson, 1988)

Although the skin retrieves information about the outside world, the information becomes meaningful and useful for the self only in the brain. The brain is a complex network able to process in a parallel and in an organized manner inputs from the senses. It also sends information to the body, thereby controlling its reactions.

Since 1929, electrical activity of the brain has been recorded with electroencephalography. But only in the 1970's it became possible to measure the weak neuromagnetic fields, due to the development of extremely sensitive superconducting probes. Today, whole-scalp magnetoencephalography (MEG) is a good technique for non-invasive studies of the brain function. Owing to its excellent temporal resolution, MEG allows us to follow in detail the temporal activation sequences of different cortical regions.

This thesis aims to characterize a particular somatosensory cortical region, the secondary somatosensory cortex SII, and to study its role in the processing of somatosensory information. In order to fulfill these aims, different types of stimulators and different methods to analyze the MEG data had to be used.

2. REVIEW OF LITERATURE

2.1 MAGNETOENCEPHALOGRAPHY

Neuronal currents

The neuron is the basic active unit of the brain. It is surrounded by a membrane, which due to its channels and pumps plays a very important role in the generation and propagation of electrical signals. At rest the intracellular medium contains more potassium (K^+) than sodium (Na^+). Due to this imbalance of ion concentration between the inside and the outside of the neuron, the inside is negative relative to the exterior. The value of the resting potential usually varies between -60 mV and -70 mV, depending on the nature of the neuron (Koester, 1991).

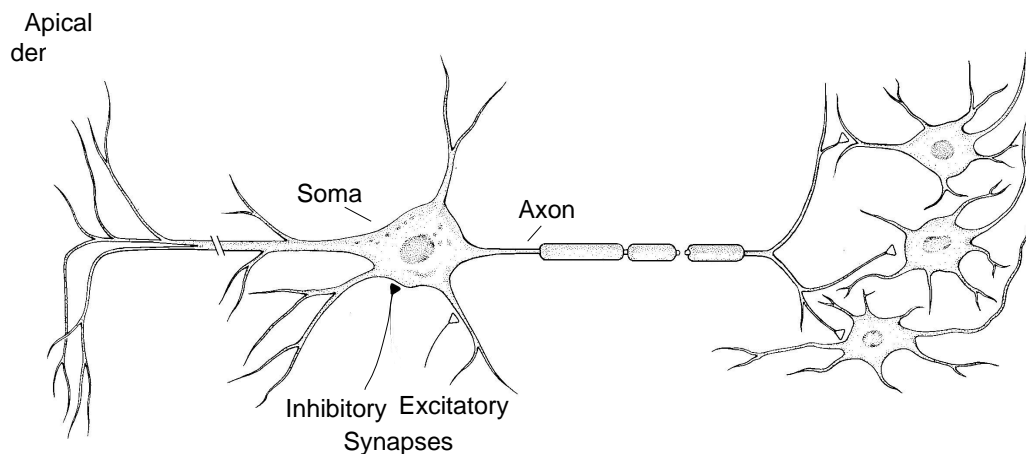

Figure 2.1: Major regions of a neuron. Modified from Kandel (1991).

When a sensory stimulus arrives to the dendrites of a neuron, the ion channels open and the membrane potential changes. When the potential reaches a certain threshold, an action potential travels along the axon until it reaches the next neuron. At the synapse, the pre-synaptic neuron releases neurotransmitter molecules which attach to the receptors of the post-synaptic cell, changing its resting potential.

Both action and synaptic currents give rise to magnetic fields. During an action potential two currents flow in opposite directions along the axon, giving rise to a quadrupolar magnetic field pattern, the strength of which decreases rapidly with the distance, as $1/r^3$. The synaptic current produces a dipolar magnetic field pattern that decreases only as $1/r^2$. The synaptic currents last 10–30 times longer than the 1-ms action potentials. For both of these reasons the postsynaptic currents are the dominating sources of the magnetic field detected outside the head; for a review see *e.g.* Lopes da Silva (1999).

The neuromagnetic fields measured with MEG are most probably generated in the apical dendrites of the cortical pyramidal neurons that lie parallel to each other and perpendicular to the cortical surface. To produce a measurable field outside the head several tens of thousands of neurons have to act synchronously (Hari, 1990).

Neuromagnetic fields

The following discussion is mainly based on the review article by Hämäläinen *et al.* (1993). The electrical activity in the brain and the electromagnetic fields measured outside the skull are defined by the laws of electromagnetism. The fields obey the classical Maxwell equations:

$$\nabla \cdot \mathbf{E} = \rho / \varepsilon_0 \quad (1)$$

$$\nabla \times \mathbf{E} = -\partial \mathbf{B} / \partial t \quad (2)$$

$$\nabla \cdot \mathbf{B} = 0 \quad (3)$$

$$\nabla \times \mathbf{B} = \mu_0 (\mathbf{J} + \varepsilon_0 \partial \mathbf{E} / \partial t) \quad (4)$$

where \mathbf{E} and \mathbf{B} are the electric and magnetic fields, \mathbf{J} and ρ are the total current and charge density, and ε_0 and μ_0 are the permittivity and permeability of the free space, respectively. Since the frequency of bioelectrical signals is below 1 kHz, Eq. (2) and Eq. (4) can be simplified using the quasistatic approximation by neglecting the time-dependent terms $\partial \mathbf{B} / \partial t$ and $\partial \mathbf{E} / \partial t$.

The total magnetic field generated by a current distribution may be obtained using the Ampère-Laplace law:

$$\mathbf{B}(\mathbf{r}) = \frac{\mu_0}{4\pi} \int \frac{\mathbf{J}(\mathbf{r}') \times (\mathbf{r} - \mathbf{r}')}{|\mathbf{r} - \mathbf{r}'|^3} dv' \quad (5)$$

where \mathbf{r} is the point at which the field is computed and \mathbf{r}' is the location of the source.

The total current density \mathbf{J} is usually divided into two components, the primary current \mathbf{J}_p , generated by the neuronal activity, and the volume current \mathbf{J}_v which is a passive current driven by the macroscopic electric potential V and conductivity σ :

$$\mathbf{J}_p = \mathbf{J} - \mathbf{J}_v = \mathbf{J} - (-\sigma \nabla V) \quad (6)$$

In neuromagnetism, the forward problem consists of calculating the magnetic field \mathbf{B} outside the head produced by a distribution of primary currents \mathbf{J}_p within the brain. From Eq. (4), and since $\nabla \cdot (\nabla \times \mathbf{B}) = 0$, $\nabla \cdot \mathbf{J} = 0$ and consequently $\nabla \cdot \mathbf{J}_p = \nabla \cdot (\nabla \sigma V)$. Eq. (5) can then be re-written as:

$$\mathbf{B}(\mathbf{r}) = \frac{\mu_0}{4\pi} \int (\mathbf{J}_p + V \nabla' \sigma) \times \frac{(\mathbf{r} - \mathbf{r}')}{|\mathbf{r} - \mathbf{r}'|^3} dv' . \quad (7)$$

Equations (6) and (7) are the basis for solving the forward problem.

In MEG and EEG, the main task consists of locating the sources that produce a magnetic field or electrical potential distribution, respectively. This so-called inverse problem has no unique solution, as was already shown by Helmholtz (1853), because different current distributions inside the brain produce the same electromagnetic field distribution outside the skull. Therefore, it is necessary to solve the forward problem to find constraints to the inverse problem.

Thus, models for the conductor and source generators are necessary. The head is often thought of as a spherically symmetric volume conductor. This model fits quite

well with the geometry of the brain, especially over the somatosensory cortices studied in this thesis. Realistic models can also be used, but the data analysis becomes more time consuming and significant differences between the two models are observed mainly in the frontal and deep brain regions (Tarkiainen *et al.*, 2002). In a sphere, radial currents do not produce magnetic field outside. Thus, only primary currents with a tangential component can generate MEG signals detectable outside the head. Therefore, MEG is mainly sensitive to neuronal activity in the fissural cortex, where most of the sensory projection areas are located.

The equivalent current dipole (ECD) can be used as a model of the current generator if the neuronal activity is confined to a small region when observed from a distance. The location, orientation and strength of the current dipole are estimated by a least-squares search. The multi-dipole model can be used when multiple cortical regions are activated simultaneously, provided that the sources are relatively far from each other and/or their orientations differ. In this kind of model we assume that several brain areas are active simultaneously and that the local currents (dipoles) maintain their positions and orientations during the time of interest. Nevertheless, the dipoles can vary in their strength, and in the least-squares search the dipole strengths are modified to produce a magnetic field pattern as similar as possible to the measured one.

Instrumentation

The brain's magnetic fields are extremely weak, ranging between 50–500 fT, about 10^9 – 10^8 orders of magnitude weaker than the geomagnetic field. To measure such small signals, it is necessary to have extremely sensitive devices and good external noise attenuation.

The development of the Superconducting QUantum Interference Device (SQUID) by Zimmerman (1970) allowed recordings of the weak biomagnetic fields (Cohen, 1972). The SQUID consists on a superconducting ring interrupted by one or two resistive Josephson junctions (Josephson, 1962), which are characterized by a critical current I_C ; a current smaller than I_C flows without any resistance in the ring. However, if it exceeds I_C , due to addition of a current induced by a magnetic flux, the ring will become resistive.

When an appropriate bias current is fed through the SQUID, the output voltage changes periodically with the applied magnetic flux. This voltage can be amplified and used to generate a feedback current. Finally, this current is inductively coupled back into the SQUID loop to cancel the applied signal flux. As a result, the SQUID is locked at a single flux working point, and changes in the flux applied to the SQUID can be directly measured from the feedback current (Fagaly, 1990).

The magnetic flux is coupled to the SQUID by a flux transformer, which consists of a pickup coil and a signal coil, and can be adjusted to achieve an optimal signal-to-noise ratio (SNR). Since both the SQUID and the flux transformer are superconducting, the whole unit has to be immersed in liquid helium at 4 K. A magnetometer type pickup coil contains a single loop. The first-order axial gradiometer (Fig. 2.2a) consists of two coils wound in opposite directions. This coil configuration cancels the homogeneous magnetic flux produced by distant sources but is sensitive to inhomogeneous magnetic fields produced by close sources. The maximum signals are detected on both sides of the source. The planar gradiometer (Fig. 2.2b) has a figure-of-eight shape, with two opposite coils on the same plane. It gives the strongest signal above the active current source.

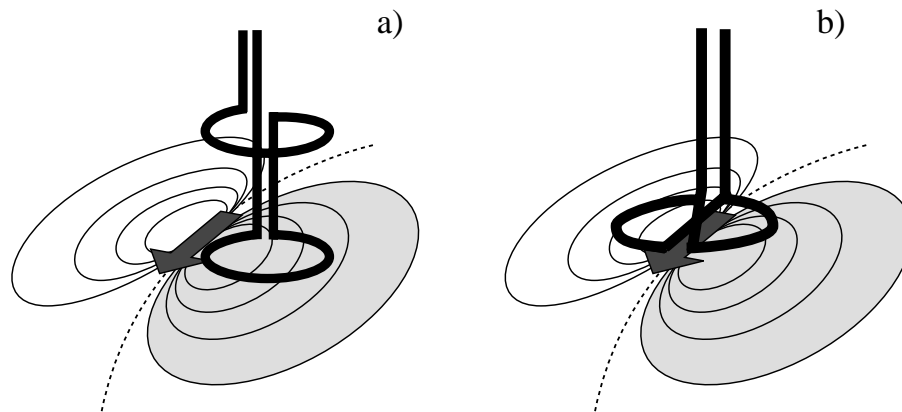

Figure 2.2: Illustration of two types of pickup coils used for measuring magnetic activity of the brain: a) axial gradiometer and b) planar gradiometer. The pickup coils shown are located where they measure the maximum signal from the source. Adapted from Hari (1999).

Although a flux transformer is able to minimize external magnetic disturbances, the most effective way to perform the measurements is inside a magnetically shielded room. Such a room typically consists of several layers of μ -metal and aluminum for the suppression of low- and high-frequency magnetic fields, respectively. An alternative, or addition, to such passive shielding is active shielding which generates an appropriate magnetic field by compensation coils to cancel the external magnetic field.

The magnetoencephalographic recordings for this thesis were carried out using the Neuromag-122TM (Ahonen *et al.*, 1993) and the VectorviewTM devices (Fig. 2.3); both prototypes of devices were designed and constructed by Neuromag Ltd. (Helsinki, Finland). The Neuromag-122TM contains 122 planar gradiometers arranged in 61 pairs, which measure two orthogonal derivatives of the magnetic field. This device was placed in a magnetically shielded room comprising 3 layers of aluminum and μ -metal. VectorviewTM consists of 102 identical triple sensors, each sensor containing two orthogonal planar gradiometers and one magnetometer, resulting in a total of 306 sensors. This system was placed inside a magnetically shielded room, comprising 2 layers of aluminum and μ -metal and active noise compensation.

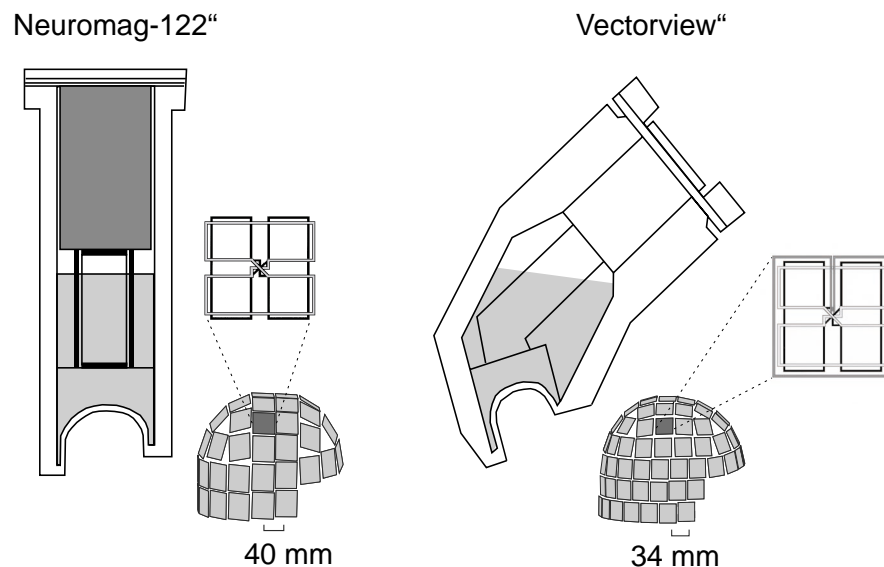

Figure 2.3: Schematic view of the two used neuromagnetometers: Neuromag-122TM and the VectorviewTM. Adapted from Ahonen *et al.* (1993) and VectorviewTM Users Guide.

In order to model the acquired neuromagnetic activity, information is required about the relative position and orientation of the head with regard to the system. Therefore head-position-indicator (HPI) coils were attached to the scalp of the subject, their positions were digitized with respect to anatomical landmarks, and a current was fed through them during the measurements. The locations of the coils with respect to the neuromagnetometer were then computed based on the measured signals.

Applications of MEG

Since its development in the 1970's, MEG has been used mainly for basic research of the human brain. Sensory systems like the visual (Brenner *et al.*, 1975; Teyler *et al.*, 1975), somatosensory (Hari *et al.*, 1983a; 1984; Kaukoranta *et al.*, 1986) and the auditory (Reite *et al.*, 1978; Elberling *et al.*, 1980; Hari *et al.*, 1980; Romani *et al.*, 1982) have been widely studied to provide information about human brain functions. Olfactory (Kettenmann *et al.*, 1996) and gustatory systems (Murayama *et al.*, 1996) have been investigated to a lesser extent, and studies of acute pain are increasing at present (Hari *et al.*, 1983b; Huttunen *et al.*, 1986; Kakigi *et al.*, 1989).

MEG has also been employed to study oscillatory activity of the brain including spontaneous occipital alpha- (Cohen, 1968) and somato-sensory mu-rhythm (Tiihonen *et al.*, 1989), and cortex–muscle coherence during muscular contraction (Salenius *et al.*, 1997).

With the development of whole-head MEG systems, it has become possible to monitor the network of activation during higher cognitive brain functions. Salmelin *et al.* (1994) were able to follow the sequence of brain activation when subjects were naming pictures of objects. MEG responses to pictures of faces were observed in the right posterior fusiform gyrus (Lu *et al.*, 1991). Further information has been obtained from groups of subjects with cognitive deficits like dyslexia (Salmelin *et al.*, 1996; Helenius *et al.*, 1999) or autism (Avikainen *et al.*, 1999; Lewine *et al.*, 1999).

The routine clinical applications of MEG are localization of epileptic foci (Barth *et al.*, 1982; Paetau *et al.*, 1990). MEG is also useful in mapping functional deficits in subjects who have brain lesions caused, for instance by stroke (Forss *et al.*, 1999). A useful clinical application is the pre-surgical mapping of the somatosensory and motor cortex (Gallen *et al.*, 1993; Mäkelä *et al.*, 2001).

Many of the above MEG applications have been discussed in extensive reviews by authors from our laboratory (Hari, 1990; 1999; Hari and Salmelin, 1997; Hari and Forss, 1999; Hari and Salenius, 1999; Mäkelä and Salmelin, 1999).

Other functional neuroimaging techniques

Both EEG and MEG measure the primary electrophysiological activity arising from the postsynaptic currents in the brain. These two techniques have a sub-millisecond temporal resolution that allows follow-up of rapid changes in the cortical activity, which reflects the ongoing processing in the brain. However, even if the source of the signal is the same, these two techniques have some important differences.

In the spherical model MEG is only sensitive to the tangential currents, whereas EEG senses all current components. Moreover, the electrical potentials measured on the scalp are affected by the different conductivities of the surrounding tissues. EEG has a poorer spatial resolution than MEG (Mosher *et al.*, 1993), since the interpretation of the EEG

signals requires a precise knowledge of the thickness and conductivities of the tissues in the head.

MEG is more sensitive to cortical activity than to activity in deep structures in the brain. Combination of these two techniques can provide information about both radial and tangential sources.

Brain activity may be studied also by measuring regional blood flow metabolic changes. Functional magnetic resonance imaging (fMRI) is one of the most widely used technique to map brain's activity. When a region in the brain becomes active, its local blood supply and local oxygen concentration changes. This blood-oxygen-level-dependent signal results from different magnetic properties of hemoglobin and deoxy-hemoglobin. fMRI is a non-invasive technique with a very accurate spatial resolution, whereas its temporal resolution is at best a few hundred milliseconds (Rosen *et al.*, 1998).

In positron emission tomography (PET), positron-emitting isotopes are bound to biological compounds such as glucose. The two gamma-rays, generated by annihilation of the emitted positron with an electron, reach a pair of detectors that record the event when the particle emissions are simultaneous. This method of coincident detection allows precise localization of the site of the gamma emission. The spatial resolution of PET is about 3 mm (Saper *et al.*, 2000).

fMRI and PET give functional information about the brain activity that can be further used to constrain the regions where the neural generators of MEG signals could be located.

2.2 SOMATOSENSORY SYSTEM

Modalities and receptors

The somatosensory system is part of the nervous system responsible for the collection of sensory information from the body and the outside world. Unlike other sensory systems its receptors are all over the body and process many kinds of stimuli and sensations. There are four distinct somatic modalities: *touch*, elicited by mechanical stimulation of the body surface, *proprioception*, caused by mechanical displacement of the muscles and joints, *pain*, generated by noxious stimuli and *thermal sensation*, elicited by cool and warm stimuli.

Each of these somatosensory modalities is mediated by a distinct class of receptors, which carry information to the central nervous system. The mechanoreceptors that mediate the sensation of touch can be divided into two major functional groups: *slowly adapting receptors*, such as Merkel's receptors and Ruffini's corpuscles, which respond to a persistent stimulus, and *rapidly adapting receptors*, like the Meissner's and Pacinian corpuscles, which respond at onset and offset of the stimuli. Meissner and Merkel receptors are located in the hairless skin and, owing to their small receptive fields (2–4 mm) they can resolve very fine spatial differences. Pacinian and Ruffini's corpuscles are located in subcutaneous tissues and since they have much larger receptive fields (about 5 cm), they can only resolve coarse spatial differences (Martin and Jessell, 1991a).

Limb proprioception, which is the sense of position and movement of the limbs, is mediated by three main types of peripheral receptors: the mechanoreceptors located in the joint capsules and activated by joint movements, the muscle spindle receptors activated by muscle contraction, and the cutaneous mechanoreceptors. The complete proprioceptive sensitivity depends on the combined actions of these three types of receptors.

Afferent pathways

Sensory information from the periphery is conducted to the spinal cord by afferent nerve fibers. Individual peripheral nerves often contain both afferent and efferent fibers for the same part of the body: the fibers are separated dorsally and ventrally, respectively, near the spinal cord.

Touch and proprioceptive information ascend to the somatosensory cortex via the dorsal column–medial lemniscal pathway. The anterolateral pathway carries mainly pain and temperature information, and to a much lesser extent sensation of itch, tickle and some crude tactile sensation. The dorsal column–medial lemniscal pathway is composed of thick myelinated nerve fibers that transmit signals to the brain at velocities of 30–110 m/s, whereas the anterolateral pathway is made of much thinner myelinated fibers that relay slower information with a velocity up to 40 m/s (Guyton and Hall, 1996).

Both pathways carry information from the contralateral side of the body but the axons decussate occurs at different levels of the ascending pathways. In the dorsal column–medial lemniscal pathway the axons decussate in the medulla whereas in the anterolateral pathway the crossing occurs already in the spinal cord. Figure 2.4 shows a schematic representation of the dorsal column–medial lemniscal pathway.

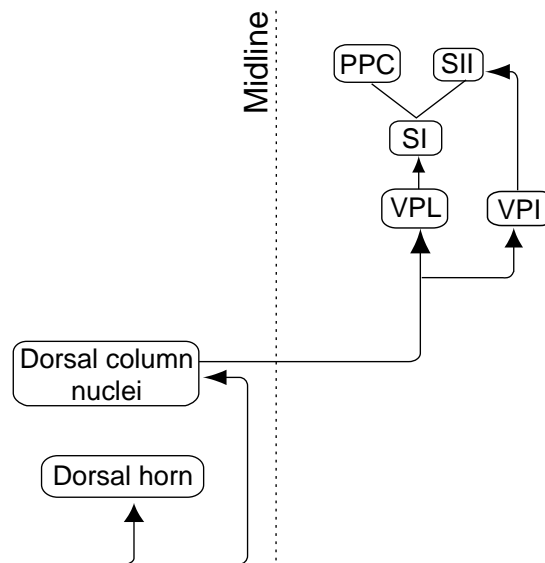

Figure 2.4: Diagram of the ascending dorsal column-medial lemniscal pathway in primates; modified from Martin (1991b). This system is responsible for conveying touch and limb proprioception to the somatosensory cortical regions.

The thalamus is the principal relay station for sensory impulses that reach the cerebral cortex from other parts of the brain and from the spinal cord. Somatic sensation is mediated by the ventral posterior nucleus (VP), which can be further divided into the lateral (VPL), medial (VPM), and inferior (VPI) nuclei. Tactile and proprioceptive information from the limbs and trunk projects to the VPL and from the face to VPM. Then the information is further projected to the somatosensory cortices, mainly to the primary somatosensory cortex SI. In primates, SII cortices receive direct thalamic input mainly from VPI (Jones and Powell, 1970; Burton, 1984; 1986; Burton *et al.*, 1990).

Primary somatosensory cortex (SI)

The SI cortex is located in the posterior bank of the central sulcus, in the parietal lobe. SI consists of four different cytoarchitectonic regions: the Brodmann areas 3a, 3b, 1, and 2 (Figure 2.5). Most thalamic projections end in areas 3b and 3a with much less direct thalamic inputs to areas 1 and 2, which receive input from areas 3a and 3b. Each one of these regions shows a clear somatotopic organization, already present in the ascending pathways and thalamus.

Each part of the body is represented in the brain in proportion to its relative importance in sensory perception. Skin areas that are more sensitive to touch, such as the lips and fingertips contain a high density of receptors and the receptive fields of the receptor are small.

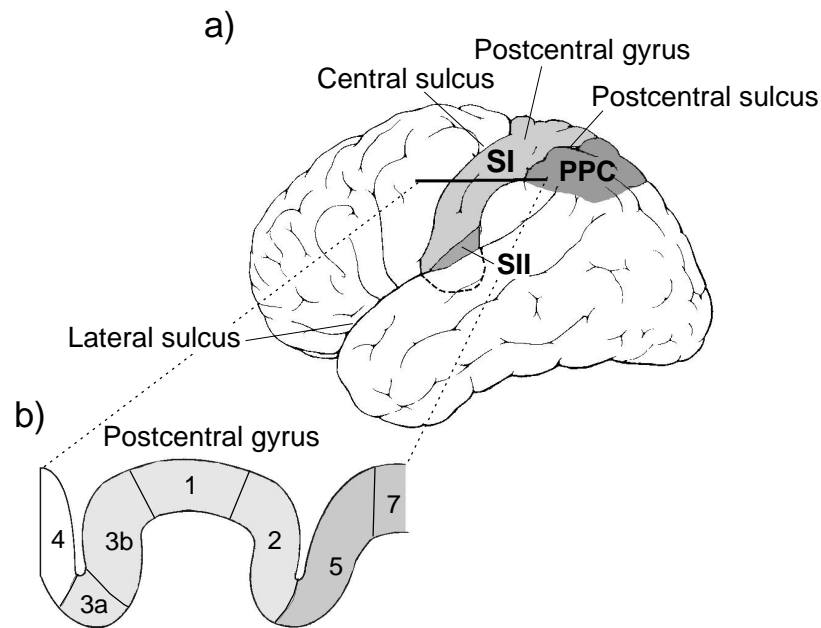

Figure 2.5: a) The three major divisions of the somatosensory cortex and b) the four cytoarchitectonic subdivisions of the SI cortex; areas 3a, 3b, 1, and 2. Adapted from Kandel (1991).

Each of the SI subregions is functionally specialized in the processing of somatosensory information. Areas 3a and 2 receive proprioceptive information from receptors in the muscles and joints, whereas areas 3b and 1 are the major arrival points for information from the receptors on the skin.

Lesions of the human SI area cause inability to locate stimuli presented to different parts of the body, and inability to judge dangerous pressure against the body, weight of objects, shapes or forms and textures of materials, and also difficulties in the position sense. The perceptions of pain and temperature is not altered significantly (Guyton and Hall, 1996).

Secondary somatosensory cortex (SII)

SII lies in the upper bank of the Sylvian fissure, and is smaller in size than SI which, together with its location, makes SII a difficult target to investigate (Penfield and Jasper, 1954; Woolsey *et al.*, 1979; Allison *et al.*, 1989; Frot and Mauguiere, 1999). SII shows signs of crude somatotopical organization, with the face area being more superficial and the foot area more medial (Penfield and Jasper, 1954; Hari *et al.*, 1993; Deuchert *et al.*, 2002). The receptive fields of SII neurons are larger than those of SI neurons and thus widely overlapping, in line with the integrative role of SII (Whitsel *et al.*, 1969; Robinson and Burton, 1980).

Contrary to SI, SII is activated bilaterally after unilateral stimulation. In monkeys, the proportion of SII neurons with bilateral (*vs.* unilateral) receptive fields varies from 25% (Burton, 1986) to 90% (Whitsel *et al.*, 1969), depending on the location of the recording. In MEG recordings, activation of SII in the hemisphere ipsilateral to the side of stimulation occurs, typically, about 15 ms later than on the contralateral side (Hari *et al.*, 1983a; 1984; 1993; Forss *et al.*, 1999; Wegner *et al.*, 2000). This delay was observed also in intracranial recordings (Frot and Mauguiere, 1999). SII receives cortical connections from the ipsilateral SI, from the contralateral SI and SII via corpus callosum, as well as thalamic projections from the VPI. Thus, the ipsilateral SII

activation could, in principle, occur via three different pathways: direct input from the thalamus, via callosal connections from the SI, or via callosal connections from the SII cortex of the opposite hemisphere.

Whether the activation of SI and SII cortices is serial or parallel is still under extensive debate. Subjects with callosal transection stimulated unilaterally, showed activation in response to unilateral stimulation only in the contralateral but not in the ipsilateral hemisphere (Fabri *et al.*, 1999). However, in one patient with a stroke in the right parietal region, the left SII cortex was activated although no SI or SII activations were observed in the right hemisphere after left median nerve stimulation (Forss *et al.*, 1999). Ipsilateral SII response was also observed in monkeys with callosal transection (Picard *et al.*, 1990).

Other animal studies have shown that inactivation of the SI cortex has little effect on the responsiveness of SII, thereby supporting parallel processing in the SI and SII cortices (Burton and Robinson, 1987; Garraghty *et al.*, 1991; Murray *et al.*, 1992; Turman *et al.*, 1992). However, ablation of the SI cortex abolished SII responses in the macaque and marmoset monkeys (Pons *et al.*, 1987; Burton *et al.*, 1990), indicating serial information transfer from SI to SII.

The role of SII in somatosensory processing is yet poorly understood. SII seems to integrate somatosensory and motor actions (Huttunen *et al.*, 1996; Forss and Jousmäki, 1998). It is deeply involved in texture discrimination (Murray and Mishkin, 1984). SII also plays an important role in tactile learning and memory; after unilateral or bilateral ablation of SII cortices monkeys show profound tactile disorders in object recognition (Ridley and Ettlinger, 1976; Garcha and Ettlinger, 1978).

Direct electrical stimulation of the SII cortex in humans produces numbness, tingling and sense of movement either in the ipsi-, contra- or bilateral body parts (Penfield and Jasper, 1954). Lesions of the human SII regions lead to tactile agnosia (Caselli, 1993).

Other somatosensory areas

Posterior parietal cortex (PPC) also receives somatosensory input. It corresponds to Brodmann's areas 5 and 7 which play a higher role in the processing of somatosensory information, like combining tactile and proprioceptive information with other sensory modalities (Hyvärinen and Poranen, 1974; Mountcastle *et al.*, 1975; Arezzo *et al.*, 1981).

Direct stimulation of the supplementary sensory area (SSA), located in the parietal mesial wall, elicited tactile sensations in some patients (Penfield and Jasper, 1954). Also direct stimulation of the supplementary motor area (SMA), in the frontal mesial wall, elicited somatic sensation, suggesting its involvement in sensory processing (Penfield and Jasper, 1954). Lesions in SSA, and possibly in SMA, cause apraxia and disturbances of somato-sensory processing (Caselli, 1993).

3. AIMS OF THE STUDY

The aim of this study was to investigate noninvasively, by means of whole-head neuromagnetic recordings, the role of the human SII cortex in the processing of somatosensory information. The specific goals of each study were:

- 1 To quantify the overlap of inputs from the two sides of the body and from the fingers of the same hand in the SII cortices (Studies I and II).
- 2 To study possible hemispheric dominance in processing tactile and proprioceptive information in SII (Studies III and IV).
- 3 To study functional connectivity between SI and SII by means of long-range phase-locked activity (Study V).
- 4 To explore the effect of motor activity from different body parts on somatosensory responses (Study VI).

4. MATERIALS AND METHODS

4.1 SUBJECTS

Altogether, a total of 28 healthy adults were studied (15 females, 13 males: 22–43 years), some of them in several experiments.

4.2 STIMULATION

Study	Number of subjects	Stimulation		
		Type	Site	Side
I	8	Electric	Median nerve	L, R
II	8	Tactile	Finger	L, R
III	14	Electric	Median nerve and skin	LR
IV	8	Passive movement	Index finger	L, R
V	10	Electric	Median nerve	R
VI	8	Electric	Median nerve	L

L– left, R– right, LR– simultaneous left and right.

Electric stimuli

The median nerves (MN) were stimulated transcutaneously at the wrists (or palmar skin of the thumbs; Study III) with 0.2-ms (Study I) or 0.3-ms constant-current pulses. The stimulus intensity exceeded the motor threshold producing a clear twitch of the thumb, although without being painful. For skin stimulation the intensity was increased 2 mA. When stimulation was bilateral the intensities were adjusted to produce subjectively equal sensations at both wrists.

Tactile stimuli

Tactile stimuli of 166 ms duration were delivered to the palmar skin of the fingers, 1.5 cm from the fingertips with balloon diaphragms driven by compressed air; Fig. 5.4 shows the experimental setup. Air pressure was adjusted to produce a clear tactile sensation and it was the same for all subjects.

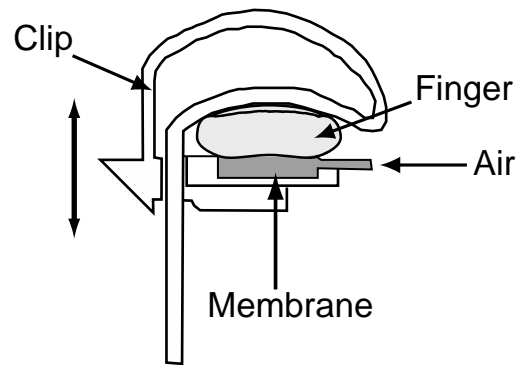

Figure 4.1: Schematic representation of the tactile stimulator (Study II). A plastic clip ensures a stable and good contact of the membrane with the skin of the fingertip. Adapted from Mertens and Lütkenhöner (2000).

Proprioceptive stimulation

The stimulator to produce passive movements was designed specifically for Study IV. A pneumatic cylinder changed the position of a lever on which the finger was resting. An acquisition computer triggered the onset of the movement. The device was surrounded by a box to attenuate acoustic noise, and the remaining noises were masked by music delivered binaurally. To minimize changes of tactile input during the movement, a piece of cardboard was attached to the palmar skin of the index finger.

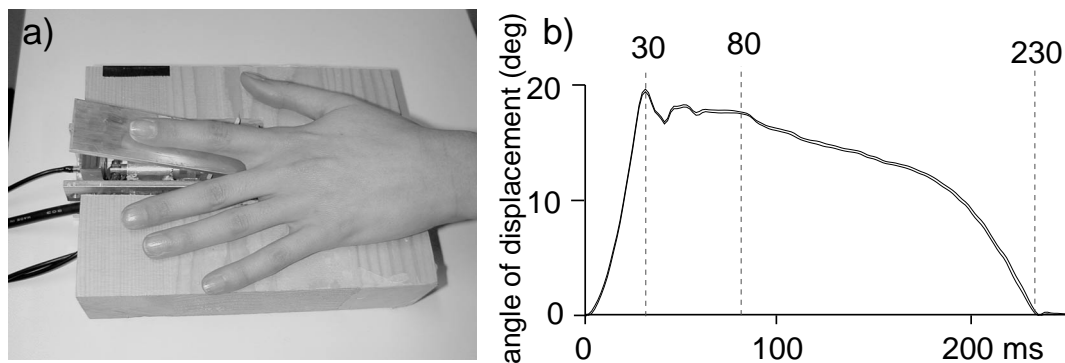

Figure 4.2: a) The pneumatic device used in Study IV and b) the time course of the movement.

4.3 RECORDINGS

All recordings were carried out inside a magnetically shielded room in the Low Temperature Laboratory. In Study I, MEG activity was recorded with Neuromag-122 whole-head system and in all other studies with the Vectorview™ system (Fig. 3.2). During recordings the subjects were sitting comfortably, with their eyes open and with the head supported against the inner wall of the magnetometer.

The exact head position with respect to the sensor helmet was found by measuring magnetic signals produced by currents led into 4 indicator coils placed at known sites on the scalp. The locations of the coils were found with respect to landmarks on the

head with a 3-D digitizer (Isotrak 3S10002, Polhemus Navigation Sciences, Colchester, VT, USA), to allow alignment of the MEG and magnetic resonance (MR) image coordinate systems. The signals were recorded with a passband of 0.03–200 Hz (0.03–190 Hz in Study I) and digitized at around 600 Hz. Epochs coinciding with signals exceeding 150 μV in the simultaneously recorded vertical electro-oculogram (EOG) were automatically rejected from the analysis.

In Study IV, classical music was delivered to the subjects binaurally to mask remaining acoustical noise produced by the stimuli. In Study VI the muscle contractions were monitored with surface electromyogram (EMG) and video camera recordings.

The magnetic resonance images of the subjects' brains were acquired with a 1.5 T system (MAGNETOM®, Siemens, Erlangen, Germany) at the Department of Radiology of the Helsinki University's Central Hospital.

4.4 DATA ANALYSIS

Source modeling

For each subject, the brain was modeled as a sphere on the basis of individual MRIs. Somatosensory evoked fields (SEFs) were obtained by averaging at least 120 epochs time-locked to the stimuli, and their generators were modeled as single current dipoles during clearly dipolar patterns. In all studies the data analysis was based on signals from the planar gradiometers only.

To identify the sources of the evoked responses, the signals were divided into several time periods, during each of which the best ECD describing the most dominant source was first found by a least-squares search using a subset (14–18) of channels over the maximum response. These calculations resulted in the 3-dimensional location, orientation, and strength of the ECD in a spherical conductor model. The validity of the model was evaluated by the goodness of fit, which tells, in percentage, how well the model accounts for the measured field variance (Hämäläinen *et al.*, 1993).

Statistical analysis of differences in dipole locations, peak latencies and source strengths was performed with paired two-tailed *t* tests (Studies I–IV and VI).

Quantification of phase-locking

In Study V, phase-locking between two signals was quantified using a wavelet analysis (Lachaux *et al.*, 1999). A complex representation of the phase for trial *i* at time *t* and frequency f_0 is given by first convoluting the signal $s_i^a(t)$ with a Morlet wavelet $w(t, f_0) = A \exp(-t^2/2\sigma_t^2) \exp(2j\pi f_0 t)$, and then normalizing it:

$$\Phi_i^a(t, f_0) = \frac{w(t, f_0) \times s_i^a(t, f_0)}{|w(t, f_0) \times s_i^a(t, f_0)|} \quad (8)$$

where $\sigma_f = 1/(2\pi\sigma_t)$. The phase-locking values (PLVs) over *N* trials between signals $s_i^a(t)$ and $s_i^b(t)$ were defined as:

$$PLV(t, f_0) = \frac{1}{N} \sum_{i=1}^N (\Phi_i^a - \Phi_i^b). \quad (9)$$

PLV estimates the variability of the phase-differences between two signals at different trials and the values quantifying the degree of phase-locking range from 0 to 1. Statistical significance of PLVs was established using a Rayleigh test (Fisher, 1993); for 120 trials a PLV above 0.17 is statically significant at $p < 0.05$.

Phase-locking statistics (PLS) was used to estimate whether the phase-locking between the two sensors resulted from a common phase-locking to the stimuli (Lachaux *et al.*, 1999). The reasoning goes as follows: assume that a set of trials is recorded by sensors a and b in response to the stimulus. If the phase-locking between the two sensors is explained by a common locking to the stimuli, then a trial from sensor a will not only be phase-locked to sensor b within that trial, but to any other trials measured by sensor b . PLS is a statistical measure which, by shuffling the trials, detects the phase locking which is not explained by phase-locking to the stimuli.

5. EXPERIMENTS

5.1 SII RESPONSES TO IPSI- AND CONTRALATERAL STIMULI (STUDY I)

The aim of this study was to find out to which extent SII responses triggered by ipsi- and contralateral stimuli interact. SEFs were recorded from eight right-handed laboratory members (3 females, 5 males). Left (L) and right (R) median nerves were stimulated electrically at the wrist (7–12 mA). The stimuli were presented in pairs that were repeated once every 2 s, with a 300-ms interstimulus interval. The four equiprobable pairs (L-L, L-R, R-L and R-R) were presented in random order within the same stimulus sequence.

Results

Figure 5.1 shows the SEFs of a representative subject to L-R stimuli.

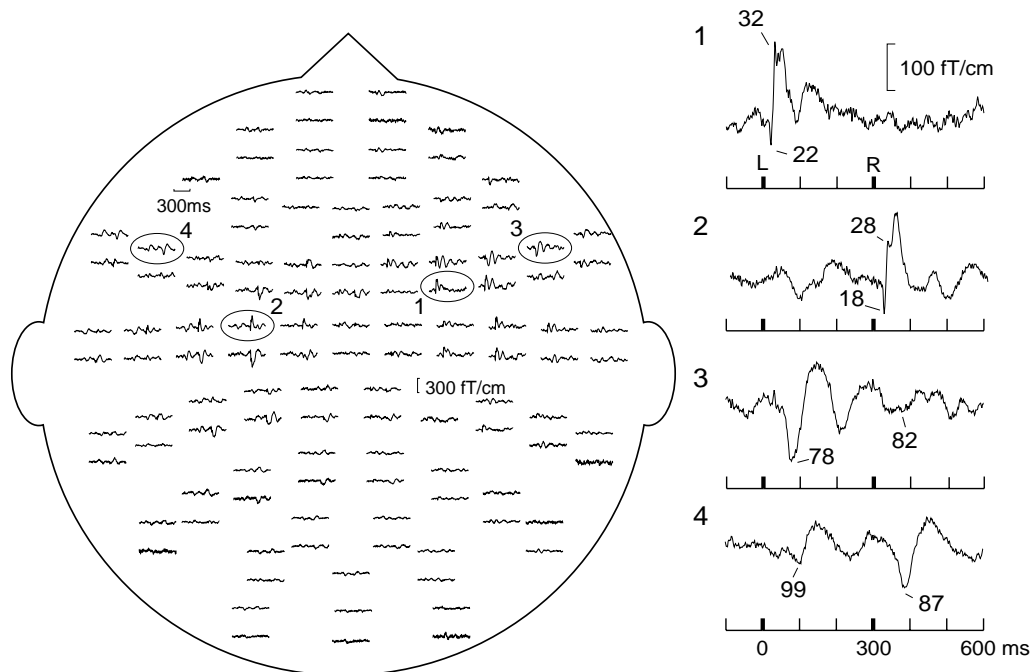

Figure 5.1: SEFs of a representative subject to a L-R stimulus pair. The head is viewed from above and, in each response pair, the upper trace illustrates the field derivative along the latitude and the lower trace along the longitude. The insert shows enlarged responses from the encircled channels.

After the first (L) stimulus, the earliest deflection N20m peaks at 22 ms, and is followed by a deflection, of opposite polarity at 32 ms over the right hemisphere. Longer latency responses peak at 78 ms in the right and at 99 ms in the left temporal regions. For the second (R) stimulus, presented 300 ms later, the earliest deflections peak at 18 ms, 28 ms in the left hemisphere and temporal-lobe activations peak at 87 ms in the left and 82 ms on the right hemisphere

Figure 5.2 shows the results of source modeling in the same subject, with the 4 source areas superimposed on the subject's own MR images. The sources for the early activity are located in the contralateral posterior wall of the central sulcus, in the hand area of the SI cortex. The longer latency responses originated bilaterally on the upper banks of the Sylvian fissures, agreeing with the SII locations. The mean SII locations (8 subjects) were about 13 mm more posterior in the left than in the right hemisphere ($p < 0.002$).

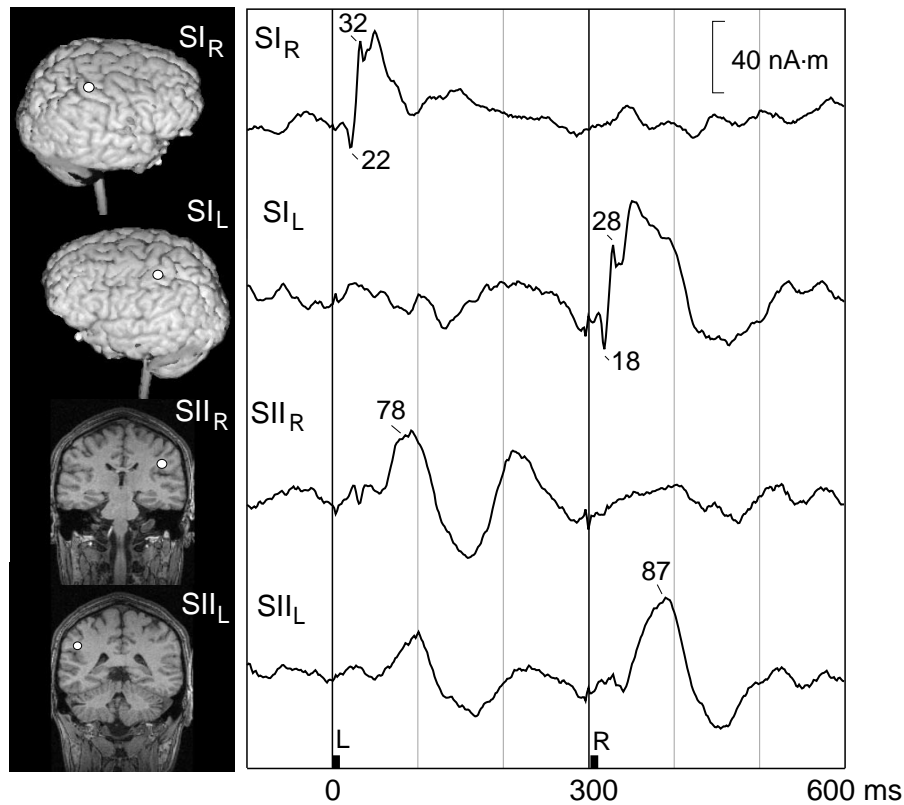

Figure 5.2: Left: Locations of the four ECDs for subject S4, superimposed on his MR images. The ECDs in SI_R and SI_L are projected to the surface of the brain in the viewing direction. Right: Strengths of the sources as a function of time in the 4-dipole model.

Figure 5.3 summarizes the mean (\pm SEM) peak latencies and normalized amplitudes of the SII responses in both hemispheres for all stimulus pairs. Normalization was done according to the maximum strength of the SII source in each subject.

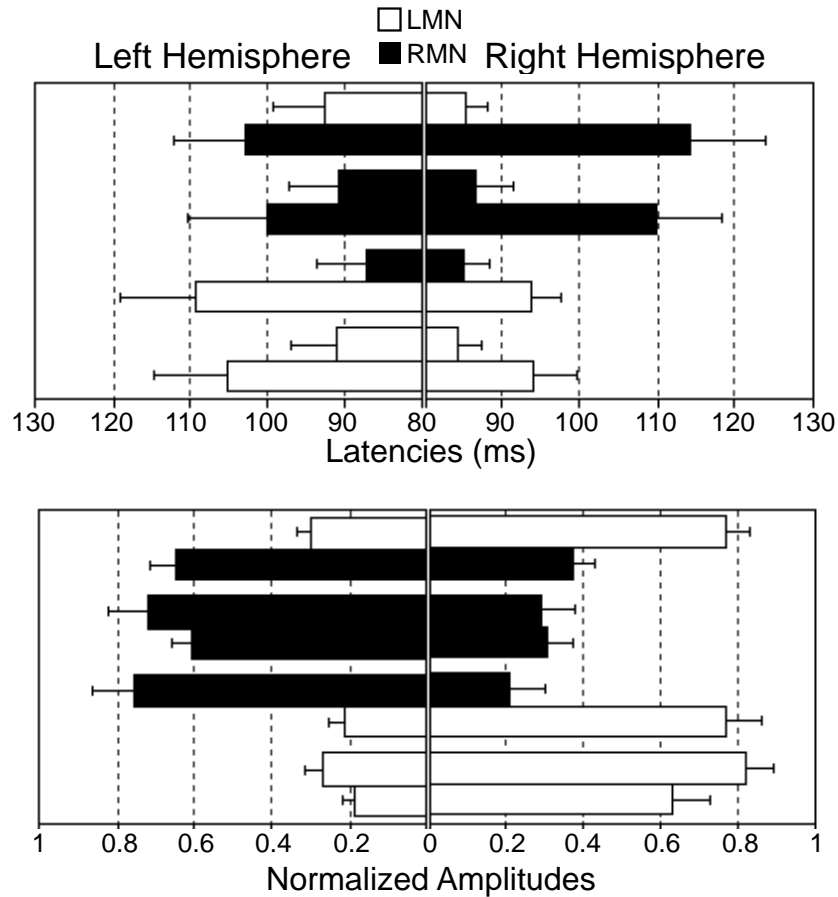

Figure 5.3: Mean (\pm SEM; 8 subjects) latencies and normalized amplitudes of the SII responses in both hemispheres for the 4 stimulus pairs. For each pair of columns, the upper corresponds to the first and the lower to the second stimulus of the pair.

The latency and amplitude patterns of Fig. 5.3 are clearly different: the peak latencies are always larger to the second than to the first response of a pair, independently of the hemisphere, whereas the amplitudes are always larger to contralateral than ipsilateral stimuli, independently of the stimulus order.

The responses to the second stimuli peaked on average 16 ms later than for the first ($p < 0.001$). This effect was stronger in the ipsi- than in the contralateral hemisphere ($p < 0.001$). Moreover, the left-hemisphere activation was systematically delayed by 5 ms, on average, with respect to the right hemisphere ($p < 0.05$).

The contralateral activation was on average 3 times ($p < 0.001$) and 2.5 times ($p < 0.001$) stronger than the ipsilateral, for the first and second stimuli, respectively.

Discussion

The bilaterality of SII activation is known for long time both in humans and in monkeys (Penfield and Jasper, 1954; Whitsel, et al., 1969). However, we now observed to which extent inputs from the two sides of the body interact in the human SII cortices. A strong interaction between inputs from the two upper limbs at the SII cortex was revealed by a clear delay of the second response compared with the first, independently of the condition and hemisphere. This result indicates that the ipsi- and contralateral inputs overlap strongly. Approximately the same SII region seemed to be activated, independently of which median nerve was stimulated a few hundred milliseconds earlier.

The observed effective integration of information from the two body halves is probably needed for the SII cortex to play an important role in supporting a unitary body image.

5.2 FUNCTIONAL OVERLAP OF FINGER REPRESENTATIONS IN SI AND SII CORTICES (STUDY II)

The purpose of this study was to determine to which extent the representations of different fingers of the two hands overlap at the SI and SII cortices. We presented tactile stimuli to the palmar skin of the right index finger (R2) and evaluated how intervening stimuli presented to three other fingers of the same (R1, R3 and R4) or of the opposite hand (L1, L3, and L4) affect the SI and SII activations (Fig. 5.4).

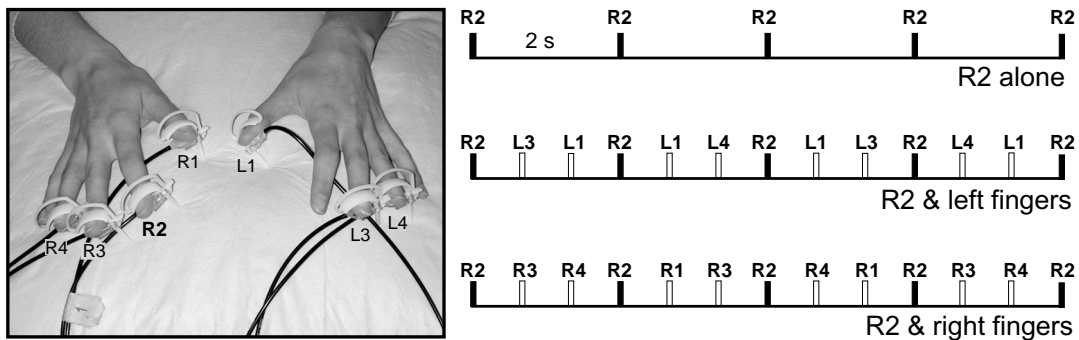

Figure 5.4: Left: Arrangement of tactile finger stimulators. Right: Illustration of the temporal structure of the three different stimulation sequences.

Results

R2 stimuli presented alone activated in all subjects the contralateral SI cortex and the SII cortices bilaterally. The SI activity peaked at 66 ± 5 ms, and it was followed by SII activity at 96 ± 3 ms in the contralateral (left) hemisphere and 13 ± 4 ms ($p < 0.05$) later in the ipsilateral (right) one. The intervening stimuli presented to either hand did not change the timing of SI and SII responses. Figure 5.5 shows the mean (+SEM) relative changes of the SI and SII source strengths during intervening stimulation.

Suppression of the SI responses to R2 stimuli alone was significant only for right-sided finger interference; the mean suppression was $18 \pm 5\%$ ($p < 0.05$).

The SII responses were suppressed by intervening stimuli presented to either hand. Intervening stimuli to fingers in the right hand suppressed the contralateral SII response by $42 \pm 12\%$ ($p < 0.01$) and the ipsilateral responses by $72 \pm 8\%$ ($p < 0.001$). For left-hand interference, the corresponding suppressions were $39 \pm 12\%$ ($p < 0.05$) and $67 \pm 6\%$ ($p < 0.001$), respectively. No significant differences were observed between the effects of left- vs. right-sided interference on SII. The suppression was about 30% stronger ($p < 0.05$) in the ipsilateral (right) than in the contralateral SII, both for right- and left-sided intervening stimuli; this asymmetric effect occurred in 5 out of 8 subjects.

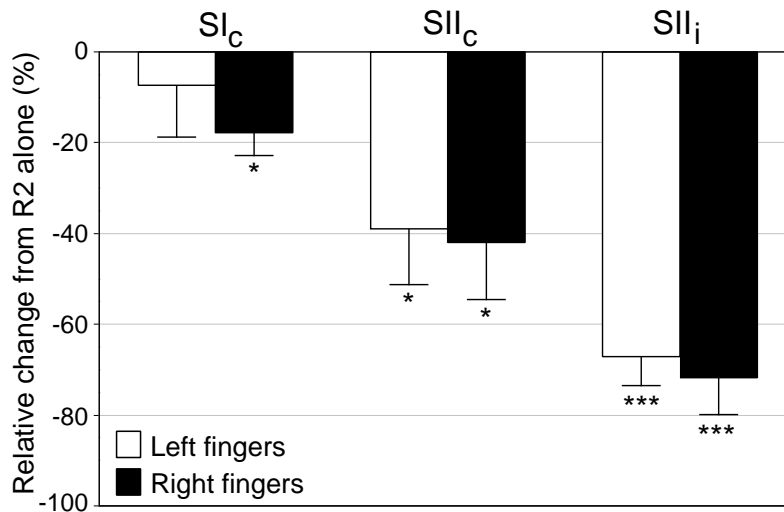

Figure 5.5: Mean (+SEM) relative changes of the source strengths from the "R2 alone" condition. The white and black bars indicate changes during left- and right-hand intervening stimuli, respectively (* $p < 0.05$, *** $p < 0.001$).

Discussion

This study revealed a strong interaction of inputs from different fingers of the two hands in the SII cortices of both hemispheres. Although the SI responses were maximally suppressed by about 20% with intervening stimuli, the SII responses were suppressed 40% and 70% in the contra- and ipsilateral hemispheres, respectively. The bilaterality of the receptive fields of the SII neurons would explain the similar suppression observed for intervening stimuli presented to either hand. We, therefore, suggested that the SII neurons with a poststimulus suppression at stimulus intervals of 600–700 ms have mainly bilateral receptive fields.

The observed suppression of activity in the SI cortex implies a functional overlap between fingers of the same hand in area 3b of the SI cortex, even with an ISI of 670 ms. This result agrees with a previous study where Biermann *et al.* (1998) showed that the interaction of the responses to simultaneous stimulation of the two fingers of the same hand is stronger for fingers adjacent to each other. Tactile stimulation of the opposite hand did not significantly suppress the SI responses, which agrees with anatomical data showing only sparse callosal connections between the hand areas of SI cortices of the two hemispheres.

In line with Study I, we observed a strong interaction of inputs from different hands in the SII cortex, indicating a major role of these regions in integration sensory information from the two body halves. Such integration is required, for example, during bimanual manipulation.

5.3 LEFT-HEMISPHERE-DOMINANT SII ACTIVATION (STUDY III)

The aim of this study was to search for a possible hemispheric dominance in SII activation after bilateral median nerve stimulation. SEFs were recorded from 14 subjects whose handedness was assessed by the Edinburgh Handedness Inventory (Oldfield, 1971). Seven subjects were right handed (three females, four males, ages 24–42 years) and seven left handed (one female, six males, ages 21–34 years). The mean handedness scores were $+69 \pm 12$ for the right-handers and -86 ± 5 for the left handers. The right and left median nerves were stimulated simultaneously once every 3 s by electrical pulses, either at the wrists or at the palmar skin of the thumbs.

Results

The final source model comprised 4 current dipoles, with one source in the SI cortex and the other two in the SII cortices of each hemisphere. Figure 5.6 represents the mean (+ SEM) source strengths for right- and left-handed subjects.

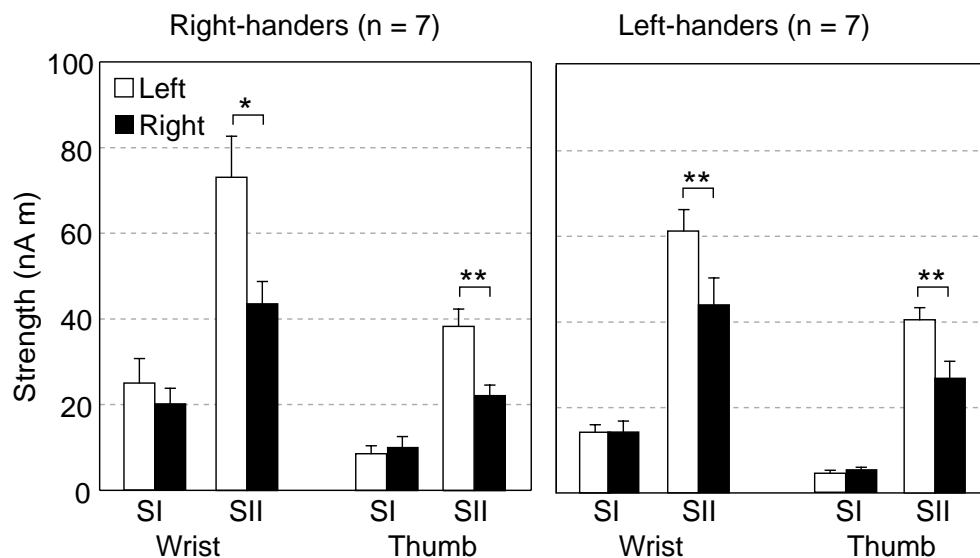

Figure 5.6: Mean (+SEM) source strengths for bilateral wrist and thumb stimuli at SI and SII cortices, shown separately for the right- and left-handed subjects (* $p < 0.05$, ** $p < 0.01$).

All sources were stronger for nerve trunk (wrist) than for skin (thumb) stimuli ($p < 0.001$). Whereas SI activations were equally strong in both hemispheres to both stimuli, SII activations showed a left-hemisphere dominance in both subject groups. Figure 5.7 shows the mean (+ SEM) left/right ratio for source strength.

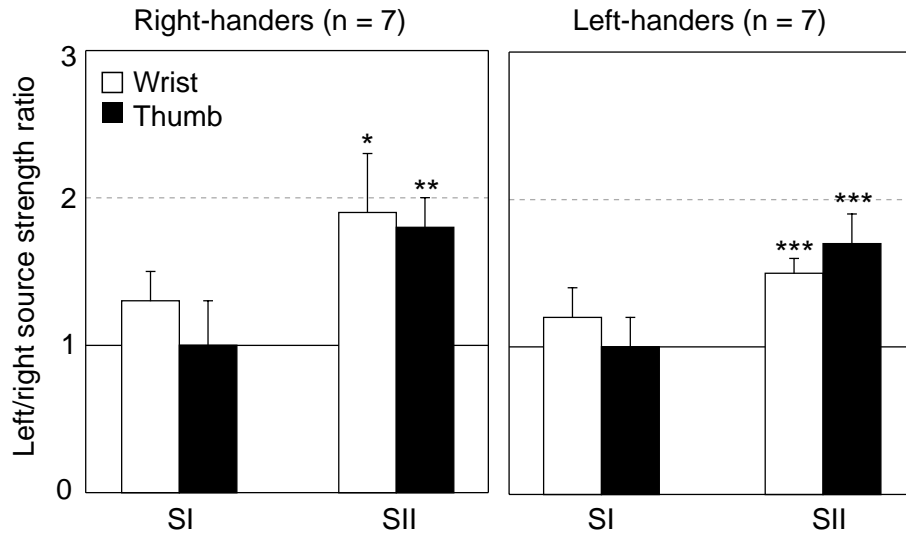

Figure 5.7: Mean (+ SEM) ratios of the source strengths in the left vs. right hemisphere, shown separately for wrist and thumb stimuli (* $p < 0.05$, ** $p < 0.01$, *** $p < 0.001$).

For the right-handed group, the SII activation was 1.9 ± 0.4 ($p < 0.05$) and 1.8 ± 0.2 times ($p < 0.01$) stronger in the left than in the right hemisphere for wrist and thumb stimuli, respectively. The corresponding values for left-handers were 1.5 ± 0.1 ($p < 0.001$) and 1.7 ± 0.2 ($p < 0.001$). These results did not differ statistically significantly between the two subject groups.

The SI activity peaked about 5 ms later, and the SII activity 8 ms later for thumb than wrist stimuli. No significant differences were observed between the two subject groups. These latency data agree with previous studies (Hashimoto, 1987; Forss *et al.*, 1994b).

Discussion

This study reveals a completely novel feature in the human SII cortex. Left-hemisphere dominant SII activity occurred after simultaneous bilateral median nerve stimulation, independently on the handedness of the subjects. This pattern was observed for both wrist (nerve trunk) and thumb (skin) stimuli.

Because the 20-ms deflection increases with the stimulus intensity (Jousmäki and Forss, 1998), the symmetric SI activation indicates that the observed difference was not due to different stimulation intensities.

Although previous studies have emphasized contralateral dominance of SII activity after unilateral stimuli (Hari *et al.*, 1983a; Kaukoranta *et al.*, 1986; Forss *et al.*, 1994b), stronger left SII activation has been previously observed in MEG recordings after unilateral (Forss *et al.*, 1994a; 1999; Wegner *et al.*, 2000) and bilateral (Shimojo *et al.*, 1996) median nerve stimuli. When a stimulus is presented to one side of the body only, then the contralateral SII region is activated earlier and more strongly than the ipsilateral one. However, the present results indicate that when both sides of the body are stimulated simultaneously and with equal intensities, then the left SII dominates over the right one, both in left- and right-handed subjects.

This finding suggests functional differences between the human right and left SII cortices. Stronger right SII activation has been observed after painful stimulation of the nasal mucosa (Hari *et al.*, 1997). Furthermore, the right SII seems to play an important role in the recognition of emotions from human facial expressions (Adolphs *et al.*, 2000).

Thus the available data suggest a hemispheric specialization of the SII cortex in the processing of somatosensory information, with the right SII being more sensitive to emotion-related aspects of the sensory processing, and the left SII more involved in tactile and proprioceptive processing.

5.4 CORTICAL ACTIVATION AFTER PASSIVE MOVEMENTS OF THE INDEX FINGER (STUDY IV)

The aim of this study was to compare SI and SII activations induced by passive movements of the right and left index finger. The fingers of 8 right-handed subjects were passively extended, in successive sessions, once every 3 s. The movement started with an extension of 30 ms (19° , mean angular velocity $630^\circ/\text{s}$) and was followed by a 50-ms period during which the finger was maintained in maximal extension. Finally, the finger was returned to the resting position for the next 150 ms.

Results

Figure 5.8 shows SEFs from a representative subject to left and right index finger extensions (LFE and RFE, respectively). The inserts show enlarged responses from the encircled channels.

The earliest deflection peaked around 40 ms after the extension onset, and it was followed by later activity peaking around 70 ms. Both these deflections were generated in the SI cortex, contralateral to the extension. Later activity was observed around 80 ms in the left SII region. Less prominent ipsilateral SI activity was found in five subjects for LFE and in six subjects for RFE.

The 40-ms SI deflection was seen in all and the 70-ms SI deflection in seven out of eight subjects. The later deflection, originated in the left SII region, was observed in six subjects for LFE and in five for RFE. One subject showed bilateral SII activity for both RFE and LFE, and two subjects to LFE. Although no SII activations were observed in two subjects, in all the others the SII cortex was activated in a left-hemisphere dominant manner.

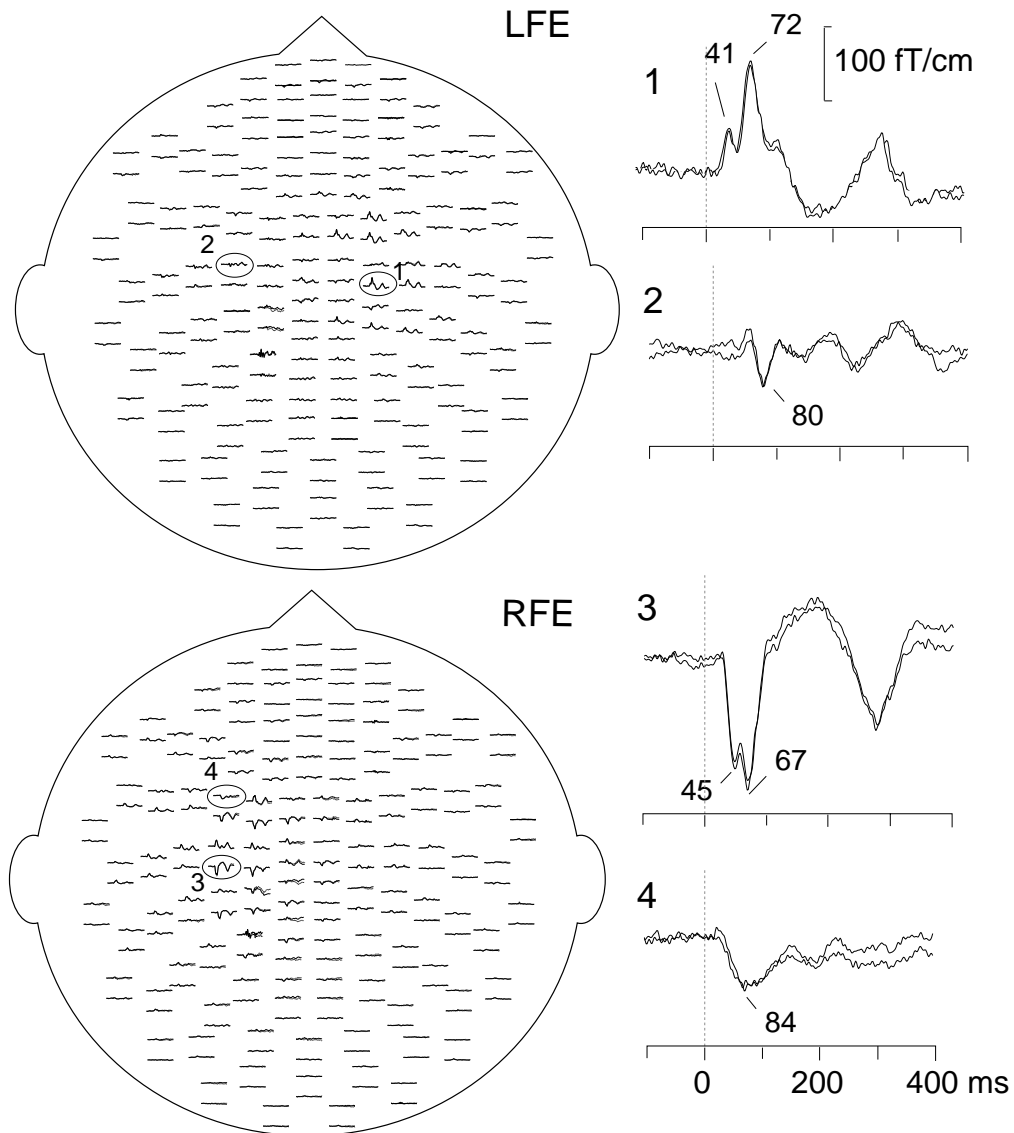

Figure 5.8: Distribution of SEFs of subject S7 to left and right index finger extensions (LFE and RFE, respectively). The inserts show enlarged responses from the encircled channels. The two superimposed traces represent the reproducibility of the signals.

Figure 5.9 shows the mean (\pm SEM) strengths of the SI and SII sources in both hemispheres. At SI, the responses were always clearly stronger in the hemisphere contra- than ipsilateral to the stimuli. In addition, the SII sources were stronger in the left than in the right hemisphere, both for LFE and RFE.

Both onsets and offsets of the stimuli elicited transient signals in SI. In SII no activity was observed during the offset of the stimuli, agreeing with a longer recovery cycle in the SII region (Hari *et al.*, 1993; Forss *et al.*, 2001).

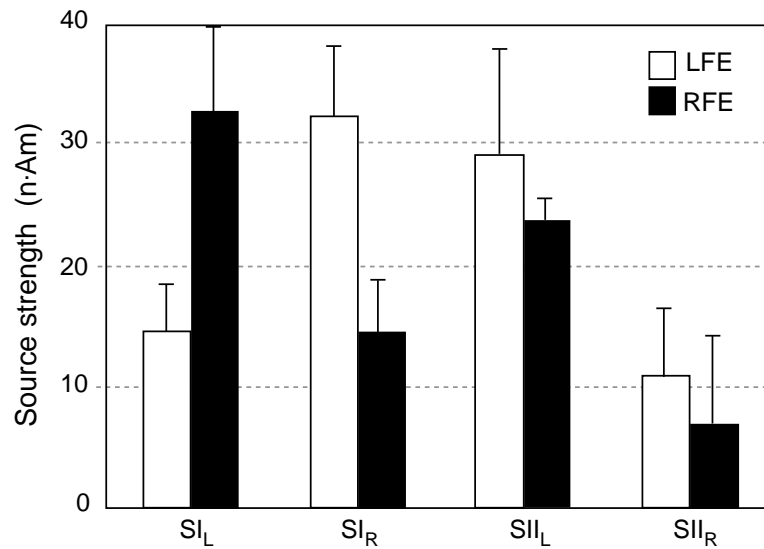

Figure 5.9: Mean (+ SEM) source strengths for SI_L, SI_R, SII_L, and SII_R activations for LFE and RFE.

Discussion

The most striking difference of our results compared with a previous EEG study (Alary *et al.*, 1998) was the left-hemisphere dominance of the SII activation in most subjects, regardless of the side of finger extension. The typically weaker or absent SII activation in the right hemisphere contrasts with previously observed SII activations after electric stimulation of the skin or of peripheral nerves, characterized by bilateral SII activation and with contralateral predominance. The present study adds to the above literature about hemispheric specialization of sensorimotor functions, by suggesting that the left SII of healthy right-handed subjects plays a key role in processing of proprioceptive input.

5.5 PHASE-LOCKED ACTIVITY BETWEEN SI AND SII CORTICES (STUDY V)

The aim of this project was to study SI-SII long-range interactions by quantifying phase-locked activity between these two regions. Phase-locking between neuronal networks has been proposed as a mechanism for integration or exchange of information; for a review see Varela (2001). Neuromagnetic activity was recorded from 10 subjects (five females, five males, ages 22–33 years) during stimulation of the right median nerve at the wrist. In contrast to the other studies of this thesis, spontaneous ongoing activity was continuously recorded and stored for off-line analysis. Time-frequency representation was computed from all sensors using a Morlet wavelet. After selecting a sensor sensitive to activity of the left SI cortex, phase-locking between this sensor and the other 203 sensors was examined from single trial data.

Results

Figure 5.10A shows the time-frequency representation of the phase-locking values (PLVs) for subject S4, computed from the 120 trials between the sensor with the strongest 20-Hz power response over the SI_L region (REF) and the remaining 203 sensors. The PLV plots are arranged topographically according to the position of the corresponding sensor on the helmet. Significant PLVs are color-coded and for all plotted values $PLV > 0.17$ ($p < 0.05$ for $N = 120$). The sensors closeby to the REF sensor measure the same source activity and thus the high PLVs have no physiological significance there. To exclude similar leakage, we focused on phase-locking between the left SI and the right SII regions. To further reduce the possibility of erroneous interactions, we selected a channel over SII with an orthogonal orientation to the REF channel.

The insets show enlargements of the PLV plots over the right SII (a) and close to the scalp midline (b). Phase-locking between SI_L and SII_R occurs during the time interval of 80–110 ms at frequencies of 18–22 Hz.

Figure 5.10B shows the distribution of the PLVs computed during the 50–150 ms time interval for a frequency band of 18–22 Hz, substantiating that the PLVs between SI_L and SII_R are clearly separated because the values are much smaller over the midline and right parietal regions.

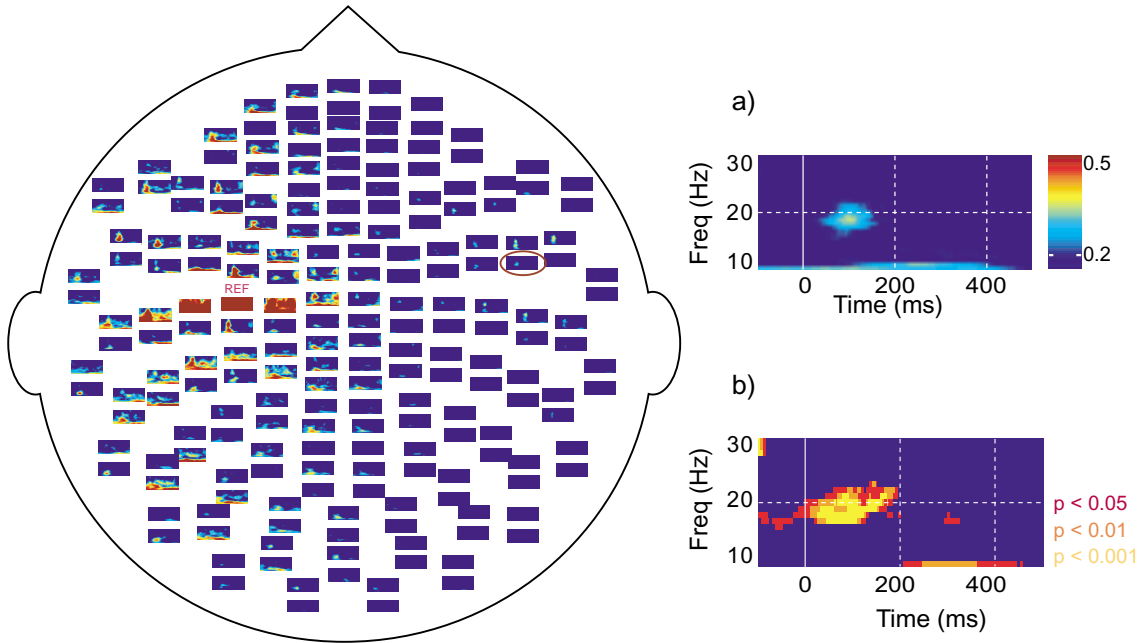

Figure 5.10: A) Time-frequency representation of PLVs for all planar gradiometers of a representative subject. The enlargements on the right are from the encircled channels, located over the right SII (a) and close to the right midline (b). B) The topographic plot on the lower right corner shows the distribution of the average PLVs across 50–150 ms for the 18–22 Hz band, plotted on the helmet.

Figure 5.11 shows the PLVs between sensors over SI_L and SII_R for all 10 subjects. The individual plots were calculated from the sensors marked on the helmets. All subjects, except S10, show significant PLVs between 15 and 25 Hz with the maximum values about 100 ms after the stimuli.

For a plausible physiological interpretation of the results, it is essential to know to which extent the observed phase-locked activity is locked to the stimuli. The PLS gives an estimate for phase-locking between two sensors which is not explained by common locking to the stimuli.

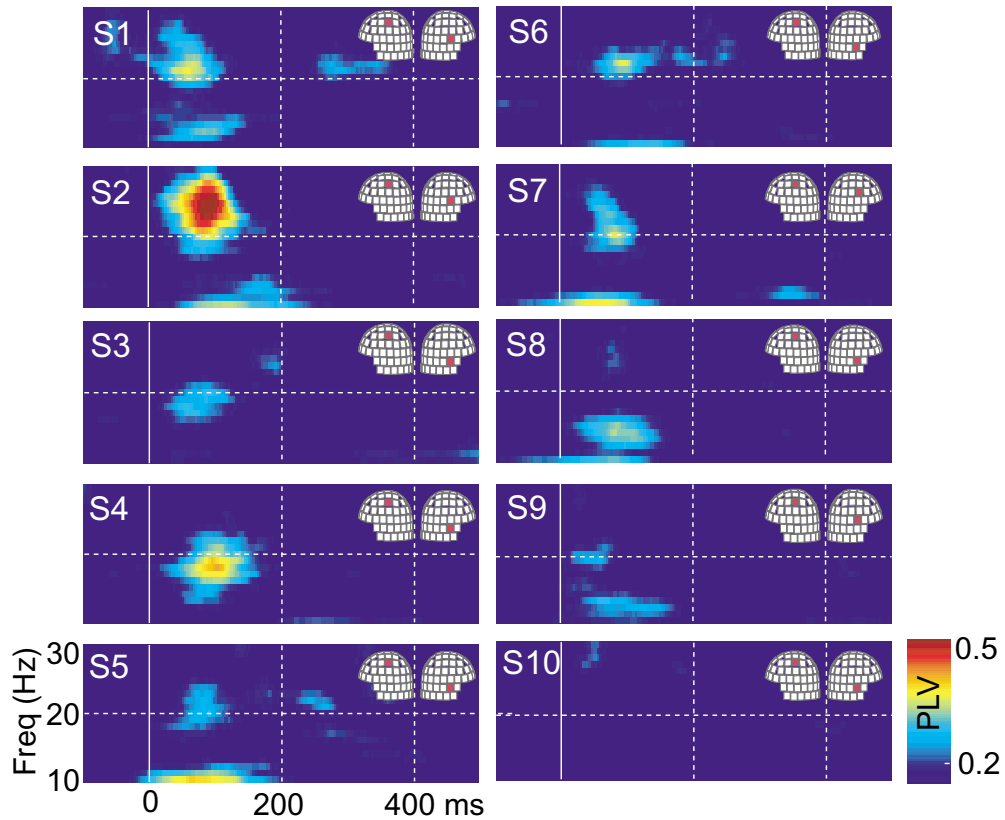

Figure 5.11: PLVs for all subjects (S1–S10), between a channel over the left SI and another channel over the right SII; the channels are indicated for each subject on the helmets. Only statistically significant PLVs ($p < 0.05$) are represented.

Figure 5.12 shows a combination of the grand average of the normalized PLVs across subjects and the PLS. We evaluated whether the relative increase in $-\log(\text{PLS})$ with respect to a baseline 100 ms prior to the stimuli is statistically significantly larger than 0 ($p < 0.05$, $N = 10$, t -test). The figure indicates that a considerable part of the phase-locking between SI and SII is not time-locked to the stimuli around 20Hz. A substantial part of the $\text{SI}_L\text{--SII}_R$ phase-locking cannot be explained by common phase-locking to the stimuli.

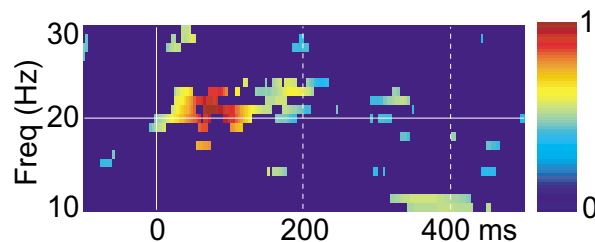

Figure 5.12: The plot shows the combination of the grand average normalized PLV and PLS. Only time-frequency ‘pixels’ of the PLV (color-code) which also had significant PLS in the grand-average are shown.

Discussion

The present result discloses a novel interaction between the human SI and SII regions. Statistically significant phase-locking was observed between sensors over

the contralateral SI cortex and the SII region of the other hemisphere; the phase-locking was strongest at about 20 Hz about 70–80 ms after the stimuli. The SI and SII sensors displaying phase-locked were far from each other and clearly separated by an area with non-phase-locking area over the scalp midline, thereby excluding the possibility that the phenomenon could be explained by the two sets of sensors measuring activity from the same source(s). Moreover, the planar gradiometers are near-sighted, being mainly sensitive to source currents just beneath the sensor. The observed phase-locking might therefore reflect real interaction between the SI and SII cortices.

Further statistical analysis, applying PLS, showed that a substantial part of the phase-locking between SI_L and SII_R was not explained by common phase-locking to the stimuli. The finding that parts of the SI and SII responses are more strongly phase-locked to each other than to the stimuli implies intrinsic interaction within the somatosensory network.

The phase-locking between SI and the SII region of the other hemisphere might be a consequence of direct communication between the two regions via callosal fibers (Jones and Powell, 1970; Burton and Robinson, 1987). Another possibility is that the thalamus drives SI and SII simultaneously, thereby causing the phase-locking. These two hypotheses are not exclusive; SI, SII, and thalamus could all be phase-locked at some instances.

Clarification of these functional connections would require either direct thalamic and cortical recordings or inferences based on lesion studies. For instance, observing phase-locking between SI and the contralateral SII region in split-brain patients would support thalamus as the driving force of the phase-locking. Future studies should also address how the somatosensory phase-locking depends on various tactile tasks. If phase-locking really reflects integration of information between the SI and SII regions, it is expected to increase with increasing demands to tactile processing. These approaches might be one way of exploring the unclear question whether SI and SII activations are parallel or serial, in healthy brains and in a non-invasive way.

5.6 EFFECT OF MUSCLE CONTRACTION ON SEFs (STUDY VI)

In this study we aimed to find out how isometric contraction of different muscles would influence activation of the somatosensory cortices. SEFs were recorded from eight right-handed subjects (3 females, 5 males, ages 28–38 years) during electrical stimulation of the left median nerve at the wrist (ISI 2 s). SEFs were first recorded with a stimulus intensity clearly exceeding the motor threshold (mean 7 mA) that produced a clear twitch of the thumb, and produced SEFs with a good SNR. Then the intensity was decreased (mean 4 mA) to produce clear tactile sensation without movement of the thumbs, and SEFs were recorded during five different conditions: rest without muscle contraction, contraction of the masseter muscles, contraction of the left deltoid muscle, contraction of the left thenar muscles, and contraction of the left tibialis anterior muscle.

Results

While the SI activity did not notably change, the SII responses were differentially affected by contraction of different muscles. Contraction of the left thenar muscles enhanced the SII responses bilaterally, in line with a previous study (Forss and Jousmäki, 1998). Contraction of the left deltoid muscle also enhanced the SII responses, although the effect was weaker. In contrast, contractions of the masseter and left tibialis anterior muscle slightly decreased the SII responses.

Figure 5.13 shows the mean (+ SEM) change in amplitude of the SI and SII responses during contraction compared with rest condition. The SI deflections N20m and P35m were not significantly changed during contraction, whereas responses from the contra and ipsilateral SII were 10–60% stronger during contraction of the left thenar muscles. The ipsilateral SII responses were significantly enlarged also during contraction of the masseter and left tibialis anterior muscles; similar effects were observed in the contralateral SII, although those changes did not reach statistical significance.

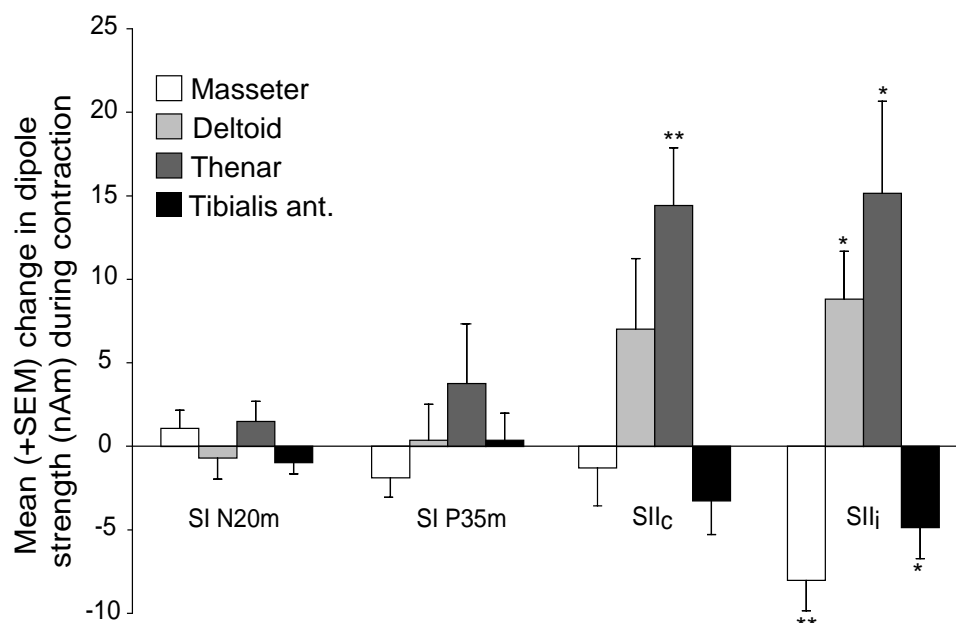

Figure 5.13: Mean (+ SEM) changes of the dipole strengths (difference of amplitudes between contraction and rest conditions) of the N20m and P35m SI responses, and of the contra- and ipsilateral SII responses (* $p < 0.05$, ** $p < 0.01$).

Discussion

This study demonstrated how contraction of various muscles in different body parts can affect differently the activation of the SII cortex. Modulation of the SII activity seems to depend on the topographical proximity of the contracting muscles to the stimulated body part; muscles close to the stimulation site (thenar and deltoid muscles) enhanced the SII responses whereas muscles further from the wrist, tibialis and masseter muscles, suppressed the SII responses.

SII cortices have been suggested to provide an important link between sensory inputs and motor cortex (Burton, 1986). In line with this view, our data show that modulation of SII activity seems to depend on the topographical proximity of the contracting muscles to the stimulated body part. The effect could take place either by changes of the synchrony or in the number of activated SII neurons. The dependence of SII activation on motor activity at different body parts implies spatial tuning which could be helpful for monitoring and correcting sensorimotor performance as suggested previously by Huttunen (1996).

6. CONCLUSIONS

MEG has proven to be an excellent technique for non-invasive studies of human somatosensory processing. Since MEG is mostly sensitive to activity within the walls of the sulci, it is particularly suitable for investigating the SII region, which is located deep in the Sylvian fissure. In fact, activation of the human secondary somatosensory cortex was first observed non-invasively with MEG almost 20 years ago (Teszner *et al.*, 1983; Hari *et al.*, 1983a; 1984) and only later confirmed with PET (Burton *et al.*, 1993) and fMRI studies (Gelnar *et al.*, 1998). PET measurement of changes in cerebral blood flow induced by vibrotactile stimulation of the hands and feet revealed additional activation of other areas in the parietal opercular cortex and insula (Burton *et al.*, 1993), which have not been prominent in our recordings probably because of the selectivity of MEG to tangential currents.

The multi-dipole model is a good approximation for the neuronal generators of SEFs, allowing the separation of the activity arising from SI and SII regions. In the studies presented in this thesis, 3- or 4-dipole models adequately explained responses elicited by peripheral stimulation. Moreover, the locations of the SI and SII sources agreed with intracranial recordings (Frot and Mauguiere, 1999) and PET studies (Paulesu *et al.*, 1997).

The results presented in the six studies of the thesis give new insights into the functional role of the human SII cortices in somatosensory processing. The first two studies showed a strong interaction of the inputs from the two hands, which indicates that SII plays an important role in integrating information from the two body halves. Studies III and IV demonstrated hemispheric specialization in the somatosensory processing: the left SII cortex was activated in a dominant way after bilateral stimulation of the median nerve and after unilateral passive movements of the index fingers. Thus the left SII might play an important role in bimanual integration. Similar left-hemisphere dominant SII activation has been observed after electrical stimulation of the dorsal penile nerve (Mäkelä *et al.*, 2002), further supporting different functional roles for the left and right SII cortices, unrelated to the handedness of the subject.

The millisecond-range temporal resolution of MEG gives information of the probable order of activation of different brain regions, but understanding the mechanisms underlying the connectivity in the neuronal network requires additional analysis tools. Therefore, it is of interest that Study V showed phase-locking between SI and SII regions, probably as a sign of joined processing or information exchange.

Finally, Study VI demonstrated that the effects of muscular contraction on the SII responses depend on the topographical proximity of the muscles to the stimulation site, emphasizing the role of SII in the spatial tuning during motor activity.

Many questions remain still without answer and further studies, for example by combining the temporal resolution of MEG with the excellent spatial accuracy of fMRI, are necessary to better understand the role of SII in somatosensory and also in multisensory processing. The results presented in this thesis will hopefully serve as a starting point for further work on this field.

REFERENCES

- Adolphs R, Damasio H, Tranel D, Cooper G, and Damasio A. A role for somatosensory cortices in the visual recognition of emotions as revealed by three-dimensional lesion mapping. *J Neurosci* 2000, 20: 2683-2690.
- Ahonen A, Hämäläinen M, Kajola M, Knuutila M, Laine J, Lounasmaa O, Parkkonen L, Simola J, and Tesche C. 122-channel SQUID instrument for investigating the magnetic signals from the human brain. *Phys Script* 1993, T49: 198-205.
- Alary F, Doyon B, Loubinoux I, Carel C, Boulanouar K, Ranjeva J, Celsis P, and Chollet F. Event-related potentials elicited by passive movements in humans: Characterization, source analysis, and comparison to fMRI. *NeuroImage* 1998, 8: 377-390.
- Allison T, McCarthy G, Wood C, Williamson P, and Spencer D. Human cortical potentials evoked by stimulation of the median nerve. II. Cytoarchitectonic areas generating long-latency activity. *J Neurophysiol* 1989, 62: 711-722.
- Arezzo J, Vaughan H, and Legatt A. Topography and intracranial sources of somatosensory evoked potentials in the monkey. II. Cortical components. *Electroencephalogr Clin Neurophysiol* 1981, 51: 1-18.
- Avikainen S, Kulomäki T, and Hari R. Normal movement reading in Asperger subjects. *Neuroreport* 1999, 10: 3467-3470.
- Barth D, Sutherling W, Engel J, and Beatty J. Neuromagnetic localization of epileptiform spike activity in the human brain. *Science* 1982, 218: 891-894.
- Biermann K, Schmitz F, Witte O, Konczak J, Freund H, and Schnitzler A. Interaction of finger representation in the human first somatosensory cortex: a neuromagnetic study. *Neurosci Lett* 1998, 251: 13-16.
- Brenner D, Williamson S, and Kaufman L. Visually evoked magnetic fields of the human brain. *Science* 1975, 190: 480-482.
- Burton H. Corticothalamic connections from the second somatosensory area and neighboring regions in the lateral sulcus of macaque monkeys. *Brain Res* 1984, 309: 367-372.
- Burton H. Second somatosensory cortex and related areas. In: *Cerebral Cortex: Sensory-Motor Areas and Aspects of Cortical Connectivity*, edited by E Jones and A Peters, Plenum. 1986, pp: 31-99.
- Burton H and Robinson C. Responses in the first or second somatosensory cortical area in cats during transient inactivation of the other ipsilateral area with lidocaine hydrochloride. *Somatosens Res* 1987, 4: 215-236.
- Burton H, Sathian K, and Shao D. Altered responses to cutaneous stimuli in the second somatosensory cortex following lesions of the postcentral gyrus in infant and juvenile macaques. *J Comp Neurol* 1990, 291: 395-414.
- Burton H, Videen T, and Raichle M. Tactile-vibration-activated foci in insular and parietal-opercular cortex studied with positron emission tomography: mapping the second somatosensory area in humans. *Somatosens Mot Res* 1993, 10: 297-308.

- Caselli R. Ventrolateral and dorsomedial somatosensory association cortex damage produces distinct somesthetic syndromes in humans. *Neurology* 1993, 43: 762-771.
- Cohen D. Magnetoencephalography: evidence of magnetic fields produced by alpha-rhythm currents. *Science* 1968, 161: 784-786.
- Cohen D. Magnetoencephalography: detection of the brain's electrical activity with a superconducting magnetometer. *Science* 1972, 175: 664-666.
- Deuchert M, Ruben J, Schwiemann J, Meyer R, Thees S, Krause T, Blankenburg F, Villringer K, Kurth R, Curio G, and Villringer A. Event-related fMRI of the somatosensory system using electrical finger stimulation. *Neuroreport* 2002, 13: 365-369.
- Elberling C, Bak C, Kofoed B, Lebech J, and Saermark K. Magnetic auditory responses from the human brain. A preliminary report. *Scand Audiol* 1980, 9: 185-190.
- Erikson J. *Wisdom and the Senses, the Way to Creativity*. WW Norton & Company. 1988.
- Fabri M, Polonara G, Quattrini A, Salvolini U, Del Pesce M, and Manzoni T. Role of the corpus callosum in the somatosensory activation of the ipsilateral cerebral cortex: an fMRI study of callosotomized patients. *Eur J Neurosci* 1999, 11: 3983-3994.
- Fagaly R. Neuromagnetic instrumentation. In: *Advances in Neurology, vol. 54: Magnetoencephalography*, edited by S Sato, Raven Press. 1990, pp: 11-32.
- Fisher N. *Statistical Analysis of Circular Data*. Cambridge University Press. 1993.
- Forss N, Hari R, Salmelin R, Ahonen A, Hämäläinen M, Kajola M, Knuutila J, and Simola J. Activation of the human posterior parietal cortex by median nerve stimulation. *Exp Brain Res* 1994a, 99: 309-315.
- Forss N, Salmelin R, and Hari R. Comparison of somatosensory evoked fields to airpuff and electric stimuli. *Electroencephalogr Clin Neurophysiol* 1994b, 92: 510-517.
- Forss N and Jousmäki V. Sensorimotor integration in human primary and secondary somatosensory cortices. *Brain Res* 1998, 781: 259-267.
- Forss N, Hietanen M, Salonen O, and Hari R. Modified activation of somatosensory cortical network in patients with right-hemisphere stroke. *Brain* 1999, 122: 1889-1899.
- Forss N, Narici L, and Hari R. Sustained activation of the human SII cortices by stimulus trains. *NeuroImage* 2001, 13: 497-501.
- Frot M and Mauguiere F. Timing and spatial distribution of somatosensory responses recorded in the upper bank of the Sylvian fissure (SII area) in humans. *Cereb Cortex* 1999, 9: 854-863.
- Gallen C, Sobel D, Waltz T, Aung M, Copeland B, Schwartz B, Hirschkoff E, and Bloom F. Noninvasive presurgical neuromagnetic mapping of somatosensory cortex. *Neurosurgery* 1993, 33: 260-268.
- Garcha H and Ettlinger G. The effects of unilateral or bilateral removals of the second somatosensory cortex (area SII): A profound tactile disorder in monkeys. *Cortex* 1978, 14: 319-326.
- Garraghty P, Florence S, Tenhula W, and Kaas J. Parallel thalamic activation of the first and second somatosensory areas in prosimian primates and tree shrews. *J Comp Neurol* 1991, 311: 289-299.

- Gelnar P, Krauss B, Szeverenyi N, and Apkarian A. Fingertip representation in the human somatosensory cortex: an fMRI study. *NeuroImage* 1998, 7: 261-283.
- Guyton A and Hall J. *Textbook of Medical Physiology*. WB Saunders Company. 1996.
- Hämäläinen M, Hari R, Ilmoniemi R, Knuutila J, and Lounasmaa O. Magnetoencephalography - theory, instrumentation, and applications to noninvasive studies of the working human brain. *Rev Mod Phys* 1993, 65: 413-497.
- Hari R. The neuromagnetic method in the study of the human auditory cortex. In: *Auditory Evoked Magnetic Fields and Electric Potentials*, edited by F Grandori, M Hoke and G Romani, Karger, Basel. 1990, pp: 222-282.
- Hari R. Magnetoencephalography as a tool of clinical neurophysiology. In: *Electroencephalography: Basic Principles, Clinical Applications, and Related Fields. 4th Edition*, edited by E Niedermeyer and F Lopes da Silva, Williams & Wilkins. 1999, pp: 1107-1134.
- Hari R, Aittoniemi K, Järvinen M, Katila T, and Varpula T. Auditory evoked transient and sustained magnetic fields of the human brain. Localization of neural generators. *Exp Brain Res* 1980, 40: 237-240.
- Hari R, Hämäläinen M, Kaukoranta E, Reinikainen K, and Teszner D. Neuromagnetic responses from the second somatosensory cortex in man. *Acta Neurol Scand* 1983a, 68: 207-212.
- Hari R, Kaukoranta E, Reinikainen K, Huopaniemie T, and Mauno J. Neuromagnetic localization of cortical activity evoked by painful dental stimulation in man. *Neurosci Lett* 1983b, 42: 77-82.
- Hari R, Reinikainen K, Kaukoranta E, Hämäläinen M, Ilmoniemi R, Penttinen A, Salminen J, and Teszner D. Somatosensory evoked cerebral magnetic fields from SI and SII in man. *Electroenceph Clin Neurophysiol* 1984, 57: 254-263.
- Hari R, Karhu J, Hämäläinen M, Knuutila J, Salonen O, Sams M, and Vilkmann V. Functional organization of the human first and second somatosensory cortices: A neuromagnetic study. *Eur J Neurosci* 1993, 5: 724-734.
- Hari R, Portin K, Kettenmann B, Jousmäki V, and Kopal G. Right-hemisphere preponderance of responses to painful CO₂ stimulation of human nasal mucosa. *Pain* 1997, 72: 145-151.
- Hari R and Salmelin R. Human cortical oscillations: a neuromagnetic view through the skull. *Trends Neurosci* 1997, 20: 44-49.
- Hari R and Forss N. Magnetoencephalography in the study of human somatosensory cortical processing. *Phil Trans R Soc Lond* 1999, 354: 1145-1154.
- Hari R and Salenius S. Rhythmical corticomotor communication. *Neuroreport* 1999, 10: R1-R10.
- Hashimoto I. Somatosensory evoked potentials elicited by air-puff stimuli generated by a new high-speed air control system. *Electroenceph Clin Neurophysiol* 1987, 67: 231-237.
- Helenius P, Tarkiainen A, Cornelissen P, Hansen P, and Salmelin R. Dissociation of normal feature analysis and deficient processing of letter-strings in dyslexic adults. *Cereb Cortex* 1999, 9: 476-483.

- Helmholtz H. Ueber einige Gesetze der Vertheilung elektrischer Ströme in körperlichen Leitern mit Anwendung auf die thierisch-elektrischen Versuche. *Ann Phys Chem* 1853, 89: 211-233, 353-377.
- Huttunen J, Kobal G, Kaukoranta E, and Hari R. Cortical responses to painful CO₂ stimulation of nasal mucosa; a magnetoencephalographic study in man. *Electroencephalogr Clin Neurophysiol* 1986, 64: 347-349.
- Huttunen J, Wikström H, Korvenoja A, Seppäläinen A, Aronen H, and Ilmoniemi R. Significance of the second somatosensory cortex in sensorimotor integration: enhancement of sensory responses during finger movements. *NeuroReport* 1996, 7: 1009-1012.
- Hyvärinen J and Poranen A. Function of the parietal associative area 7 as revealed from cellular discharges in alert monkeys. *Brain* 1974, 97: 673-692.
- Jones E and Powell T. Connexions of the somatic sensory cortex of the rhesus monkey. III. Thalamic connexions. *Brain* 1970, 93: 37-56.
- Josephson B. Possible new effects in superconductive tunneling. *Phys Lett* 1962, 1: 251-253.
- Jousmäki V and Forss N. Effects of stimulus intensity on signals from human somatosensory cortices. *NeuroReport* 1998, 9: 3427-3431.
- Kakigi R, Shibasaki H, and Ikeda A. Pain-related somatosensory evoked potentials following CO₂ laser stimulation in man. *Electroencephalogr Clin Neurophysiol* 1989, 74: 139-146.
- Kandel E. Nerve cells and behavior. In: *Principles of Neural Science*, edited by E Kandel, J Schwartz and T Jessell, Prentice-Hall International Inc. 1991, pp: 18-32.
- Kandel E and Jessell T. Touch. In: *Principles of Neural Science*, edited by E Kandel, J Schwartz and T Jessell, Prentice-Hall International Inc. 1991, pp: 367-384.
- Kaukoranta E, Hari R, Hämäläinen M, and Huttunen J. Cerebral magnetic fields evoked by peroneal nerve stimulation. *Somatosens Res* 1986, 3: 309-321.
- Kettenmann B, Jousmäki V, Portin K, Salmelin R, Kobal G, and Hari R. Odorants activate the human superior temporal sulcus. *Neurosci Lett* 1996, 203: 143-145.
- Koester J. Voltage-gated ion channels and the generation of the action potential. In: *Principles of Neural Science*, edited by E Kandel, J Schwartz and T Jessell, Prentice-Hall International Inc. 1991, pp: 104-118.
- Lachaux J, Rodriguez E, Martinerie J, and Varela F. Measuring phase synchrony in brain signals. *Hum Brain Mapp* 1999, 8: 194-208.
- Lewine JD, Andrews R, Chez M, Patil AA, Devinsky O, Smith M, Kanner A, Davis JT, Funke M, Jones G, Chong B, Provencal S, Weisend M, Lee RR, and Orrison WW, Jr. Magnetoencephalographic patterns of epileptiform activity in children with regressive autism spectrum disorders. *Pediatrics* 1999, 104: 405-418.
- Lopes da Silva F and Rotterdam A. Biophysical aspects of EEG and magnetoencephalogram generation. In: *Electroencephalography: Basic Principles, Clinical Applications and Related Fields. 4th Edition*, edited by E Niedermeyer and F Lopes da Silva, Williams & Wilkins. 1999, pp: 93-109.
- Lu S, Hämäläinen M, Hari R, Ilmoniemi R, Lounasmaa O, Sams M, and Vilkmán V. Seeing faces activates three separate areas outside the occipital visual cortex in man. *Neuroscience* 1991, 43: 287-290.

- Mäkelä J and Salmelin R. MEG spontaneous activity in patients with memory disorders. *Electroencephalogr Clin Neurophysiol* 1999, 50: 428-434.
- Mäkelä J, Kirveskari E, Seppä M, Hämäläinen M, Forss N, Avikainen S, Salonen O, Salenius S, Kovala T, Randell T, Jääskeläinen J, and Hari R. Three-dimensional integration of brain anatomy and function to facilitate intraoperative navigation around the sensorimotor strip. *Hum Brain Mapp* 2001, 12: 180-192.
- Mäkelä J, Illman M, Jousmäki V, Numminen J, Lehecka M, Salenius S, Forss N, and Hari R. Dorsal penile nerve stimulation elicits strong, left-dominant activation in the second somatosensory cortex. *Hum Brain Mapp, in press* 2002.
- Martin J and Jessell T. Modality coding in the somatic sensory system. In: *Principles of Neural Science*, edited by E Kandel, J Schwartz and T Jessell, Prentice-Hall International Inc. 1991a, pp: 341-352.
- Martin J and Jessell T. Anatomy of the somatic sensory system. In: *Principles of Neural Science*, edited by E Kandel, J Schwartz and T Jessell, Prentice-Hall International Inc. 1991b, pp: 353-366.
- Mertens M and Lütkenhöner B. Efficient neuromagnetic determination of landmarks in the somatosensory cortex. *Clin Neurophysiol* 2000, 111: 1478-1487.
- Mosher J, Spencer M, Leahy R, and Lewis P. Error bounds for EEG and MEG dipole source localization. *Electroenceph Clin Neurophysiol* 1993, 86: 303-321.
- Mountcastle VB, Lynch JC, Georgopoulos A, Sakata H, and Acuna C. Posterior parietal association cortex of the monkey: command functions for operations within extrapersonal space. *J Neurophysiol* 1975, 38: 871-908.
- Murayama N, Nakasato N, Hatanaka K, Fujita S, Igasaki T, Kanno A, and Yoshimoto T. Gustatory evoked magnetic fields in humans. *Neurosci Lett* 1996, 210: 121-123.
- Murray E and Mishkin M. Relative contributions of SII and area 5 to tactile discrimination in monkeys. *Behav Brain Res* 1984, 11: 67-83.
- Murray G, Zhang H, Kaye A, Sinnadurai T, Campbell D, and Rowe M. Parallel processing in rabbit first (SI) and second (SII) somatosensory cortical areas: effects of reversible inactivation by cooling of SI on responses in SII. *J Neurophysiol* 1992, 68: 703-710.
- Oldfield R. The assessment and analysis of handedness: the Edinburg inventory. *Neuropsychologia* 1971, 9: 97-113.
- Paetau R, Kajola M, and Hari R. Magnetoencephalography in the study of epilepsy. *Neurophysiol Clin* 1990, 20: 169-187.
- Paulesu E, Frackowiak R, and Bottini G. Maps of somatosensory systems. In: *Human Brain Function*, edited by R Frackowiak, K Friston, C Crith and R Mazziotta. 1997, pp: 183-242.
- Penfield W and Jasper H. *Epilepsy and the Functional Anatomy of the Human Brain*. 1954.
- Picard N, Lepore F, Ptito M, and Guillemot J. Bilateral interaction in the second somatosensory area (SII) of the cat and contribution of the corpus callosum. *Brain Res* 1990, 536: 97-104.
- Pons T, Garraghty P, Friedman D, and Mishkin M. Physiological evidence for serial processing in somatosensory cortex. *Science* 1987, 237: 417-420.

- Reite M, Edrich J, Zimmerman J, and Zimmerman J. Human magnetic auditory evoked fields. *Electroencephalogr Clin Neurophysiol* 1978, 45: 114-117.
- Ridley R and Ettlinger G. Impaired tactile learning and retention after removals of the second somatic sensory projection cortex (SII) in the monkey. *Brain Res* 1976, 109: 656-660.
- Robinson C and Burton H. Somatotopography organization in the second somatosensory area of *M. fasciculris*. *J Comp Neurol* 1980, 192: 43-68.
- Romani G, Williamson S, and Kaufman L. Tonotopic organization of the human auditory cortex. *Science* 1982, 216: 1339-1340.
- Rosen B, Buckner R, and Dale A. Event-related functional MRI: past, present, and future. *Proc Natl Acad Sci U S A* 1998, 95: 773-780.
- Salenius S, Portin K, Kajola M, Salmelin R, and Hari R. Cortical control of human motoneuron firing during isometric contraction. *J Neurophysiol* 1997, 77: 3401-3405.
- Salmelin R, Hari R, Lounasmaa OV, and Sams M. Dynamics of brain activation during picture naming. *Nature* 1994, 368: 463-465.
- Salmelin R, Service E, Kiesila P, Uutela K, and Salonen O. Impaired visual word processing in dyslexia revealed with magnetoencephalography. *Ann Neurol* 1996, 40: 157-162.
- Saper C, Iversen S, and Frackowiak R. Integration of sensory and motor function: the association areas of the cerebral cortex and the cognitive capabilities of the brain. In: *Principles of Neural Science*, edited by E Kandel, J Schwartz and T Jessell, McGraw-Hill. 2000, pp: 349-380.
- Shimojo M, Kakigi R, Hoshiyama M, Koyama S, Kitamura Y, and Watanabe S. Intracerebral interactions caused by bilateral median nerve stimulation in man: a magnetoencephalographic study. *Neuroscience Research* 1996, 24: 175-181.
- Tarkiainen A, Husberg M, Seppä M, and Salmelin R. The 3D topography of MEG source localization accuracy: effects of conductor model and noise. *Submitted for publication* 2002.
- Teszner D, Hari R, Nicolas P, and Varpula T. Somatosensory evoked magnetic fields: mapping and the influence of stimulus repetition rate. *Nuovo Cimento* 1983, 2D: 429-437.
- Teyler T, Cuffin B, and Cohen D. The visual evoked magnetoencephalogram. *Life Sci* 1975, 17: 683-691.
- Tiihonen J, Kajola M, and Hari R. Magnetic mu rhythm in man. *Neuroscience* 1989, 32: 793-800.
- Turman A, Ferrington D, Ghosh S, Morley J, and Rowe M. Parallel processing of tactile information in the cerebral cortex of the cat: effect of reversible inactivation of SI on responsiveness of SII neurons. *J Neurophysiol* 1992, 67: 411-429.
- Varela F, Lachaux J, Rodriguez E, and Martinerie J. The brainweb: phase synchronization and large-scale integration. *Nat Rev Neurosci* 2001, 2: 229-239.
- Wegner K, Forss N, and Salenius S. Characteristics of human contra- versus ipsilateral SII cortex. *Clin Neurophysiol* 2000, 111: 894-900.
- Whitsel B, Petrucelli L, and Werner G. Symmetry and connectivity in the map of the body surface in somatosensory area II of primates. *J Neurophysiol* 1969, 32: 170-183.

- Woolsey C, Erickson T, and Gilson W. Localization in somatic sensory and motor areas of human cerebral cortex as determined by direct recordings of evoked potentials and electrical stimulation. *J Neurosurg* 1979, 51: 476-506.
- Zimmerman J, Thiene P, and Harding J. Design and operation of a stable rf-biased superconducting point-contact quantum devices and a note on the proprieties of perfectly clean metal contacts. *J Appl Phys* 1970, 41: 1572-1580.