



THE UNIVERSITY *of* EDINBURGH

Edinburgh Research Explorer

The Effect of High Power DC-DC Converter in Offshore Multi-Terminal Medium and High Voltage DC Networks

Citation for published version:

Macpherson, D, Shek, J & Rong, X 2015, The Effect of High Power DC-DC Converter in Offshore Multi-Terminal Medium and High Voltage DC Networks. in IET 4th International Conference on Renewable Power Generation. IET.

Link:

[Link to publication record in Edinburgh Research Explorer](#)

Published In:

IET 4th International Conference on Renewable Power Generation

General rights

Copyright for the publications made accessible via the Edinburgh Research Explorer is retained by the author(s) and / or other copyright owners and it is a condition of accessing these publications that users recognise and abide by the legal requirements associated with these rights.

Take down policy

The University of Edinburgh has made every reasonable effort to ensure that Edinburgh Research Explorer content complies with UK legislation. If you believe that the public display of this file breaches copyright please contact openaccess@ed.ac.uk providing details, and we will remove access to the work immediately and investigate your claim.



THE EFFECT OF HIGH POWER DC-DC CONVERTER IN OFFSHORE MULTI-TERMINAL MEDIUM AND HIGH VOLTAGE DC NETWORKS

X. Rong, D.E. Macpherson, J.K.H. Shek*

Institute for Energy Systems, School of Engineering

The University of Edinburgh

**x.rong@ed.ac.uk*

Keywords: DC-DC Converter, Multi-Terminal HVDC, PMSG (Permanent Magnet Synchronous Generator), PWM (Pulse Width Modulation)

Abstract

There is increasing interest in interconnecting individual wind turbines in offshore wind farms using DC networks rather than AC networks. As the output from each turbine/generator is normally low (less than 6 kV), DC-DC converters may be required to step-up the voltage to an intermediate level to interconnect the turbine outputs, and another DC-DC converter to step-up this intermediate voltage to a high level for transmission to the shore. As the output from the turbines varies with wind speed, the low to intermediate voltage converter are in particular needed to be able to control its output in order to maintain a constant DC level. Such converters will introduce harmonics into the DC network, potentially resulting in substantial losses in the cables.

This paper compares the outputs from several possible voltage controlled converter topologies, utilising both single and three-phase transformers, and shows that the voltage is robust on the DC network.

1 Introduction

Wind energy is a type of renewable energy which has attracted great attention over the past two decades as it is pollution free and plentiful [8]. Wind turbines are widely built for generating electrical power, and their efficiency is increasing while their costs are reduced [8]. However, finding suitable onshore sites is becoming increasingly difficult, with both the visual effects and wildlife effects two main concerns [1, 2].

Offshore wind facilities which can be built in excess of a hundred kilometres away from the shore have much less visual impact than land-based facilities [3]. However, long transmission lines are then needed to connect offshore wind farms to the onshore electricity grids. Most of the early studies have been about AC transmission, but DC transmission technologies over long distances have significant

advantages, including higher efficiency [5]. Because of the very high cost of the HVDC cables, it is desirable for a single HVDC link to transmit the power from many individual turbines [2].

Currently, most offshore windfarms use AC interconnections between individual turbines, connecting to a single hub for conversion to DC and transmission to shore. This paper examines a system using permanent magnet generators with rectified outputs with all subsequent interconnections being DC rather than AC.

Recently, multi-terminal HVDC systems have become an attractive option as power can be transferred from more than one connection point. This type of system is very suitable for the connection between the offshore wind farms and onshore AC grids [4]. Previous studies of multi-terminal HVDC systems mostly concentrate on the control of the Voltage Source Converters (VSC).

In this paper, a radial topology multi-terminal HVDC network (Figure 1) is examined, and the performance of different types of bridge DC-DC converter in various sections of the system are compared and discussed. The reason for choosing to study the voltage controlled bridge DC-DC converter is due to its advantages of high voltage/power transmission ability and simple control principle.

The novel point of the system structure is that each wind turbine has a DC-DC converter after it, and all the power delivered to each cable (both 0.7km cable and 100km cable) is via a DC-DC converter.

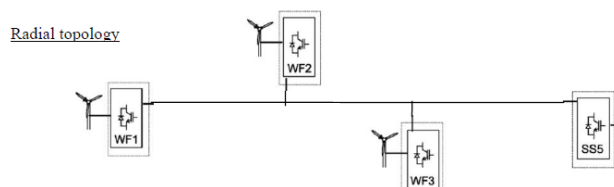

Figure 1: Radial topology for conventional multi-terminal HVDC network

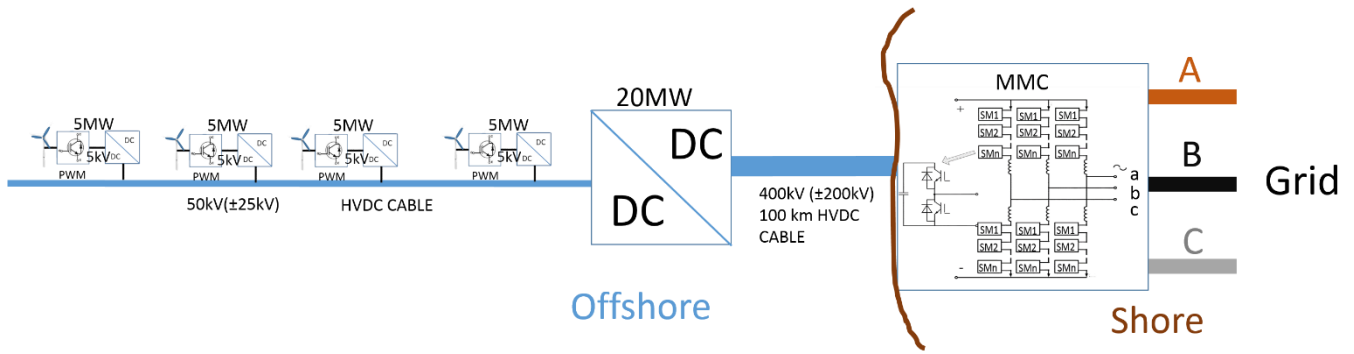

Figure 2: Offshore multi-terminal HVDC network simulation circuit

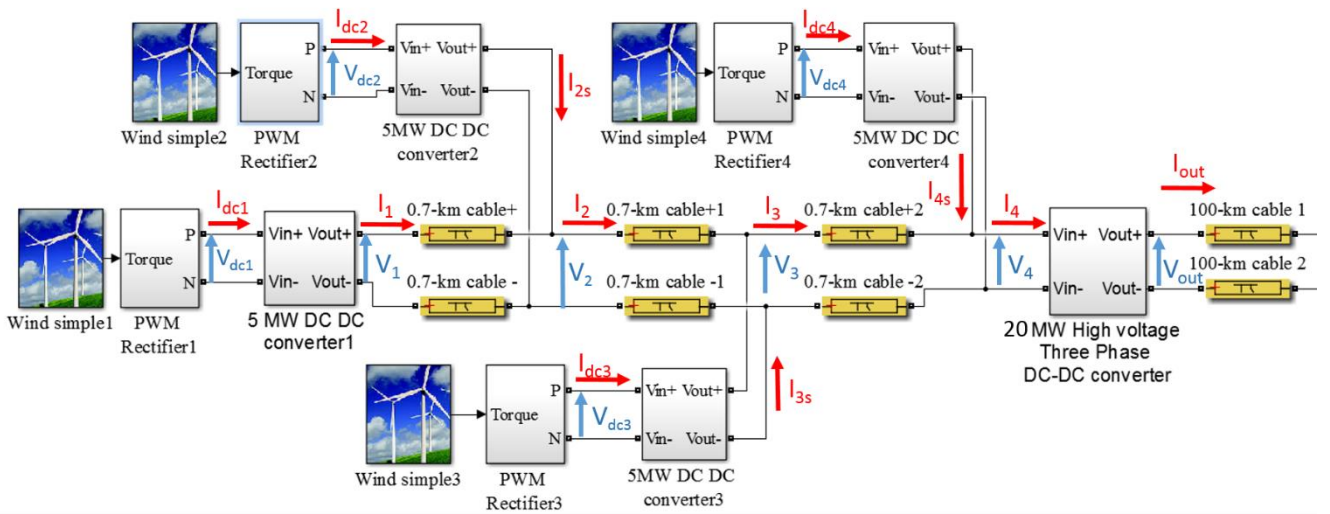

Figure 3: Sending end of the Simulink model of the multi-terminal HVDC network

2 Simulation model and methodology

This study is based on the simplified model built in Matlab/Simulink. The system circuit is as shown in Figure 2. The simulation is concentrating on the performance of the 5MW and the 20MW DC-DC converters.

A simplified model is chosen in order to have reasonable simulation time. In a real power system, there may be more than a hundred wind turbines and more than one branch before the high power (20MW in this simulation) DC-DC converter. The start-up time of each turbine is about 3 minutes [6], and the next turbine will begin to start up when the previous one is working in the steady state. In this simulation, as only the steady state results are discussed, it is assumed that all the turbines are operating in the steady state from the beginning.

The detailed sending end part of the simulation circuit is as shown in Figure 3, and the cable parameters used in Figure 3 are as listed in Table 1.

HVDC Cable π Model			
Resistance /km	Inductance /km	Capacitance /km	Number of π Section (variable)
0.013 Ω	0.466 mH	0.28 μ F	2

Table 1: HVDC cable parameters

2.1 Model of machine and PWM rectifier

Figure 4, Table 2 and Table 3 show the circuit of the PMSG, the PWM rectifier and their related parameters. The machine frequency is set to 55Hz since the machine frequency will vary and is unlikely to coincide with the grid frequency of 50Hz.

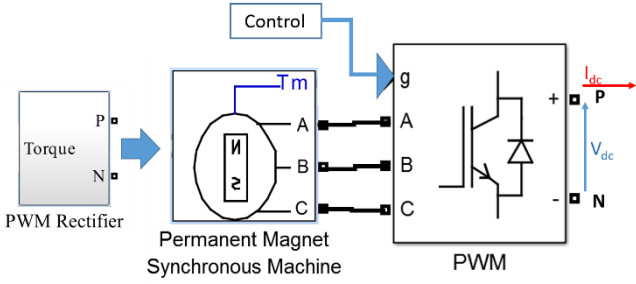

Figure 4: PMSG and PWM rectifier

Permanent Magnet Synchronous Machine (PMSG)		
Electrical Frequency	$V_{line\ rms}$	Power
55Hz	2603V	5MW

Table 2: PMSG parameters

Pulse Width Modulation (PWM)			
Switch Type	Carrier Frequency	Fundamental Frequency	Modulation Index
IGBT	1155 Hz	55 Hz	0.85

Table 3: PWM parameters [7]

2.2 Model of DC-DC converters

Figure 5 and 6 illustrate the simulation circuit of the 5MW DC-DC converter (with single-phase transformer) and the 20MW DC-DC converter (three-phase transformer) in Figure 3. Their parameters are displayed in Table 4 and 5.

Since the input of the 5MW DC-DC converter is connected to the output of the PWM rectifier, I_{dc} and V_{dc} in Figure 4 and Figure 5 are the same.

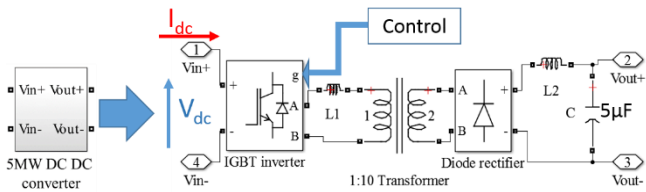

Figure 5: 5MW DC-DC converter (single-phase transformer)

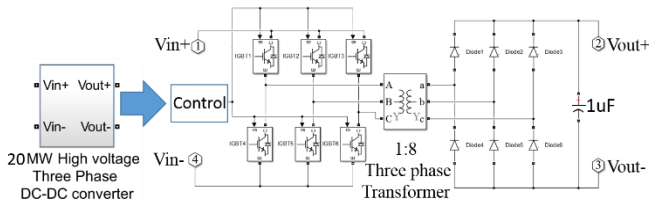

Figure 6: 20MW DC-DC converter (three-phase transformer)

5MW DC-DC converter		
Switch Type and Frequency	Transformer turns ratio	Power
IGBT 10kHz	1:10	5MW

Table 4: 5MW DC-DC converter parameters

20MW DC-DC converter		
Switch Type and Frequency	Transformer turns ratio	Power
IGBT 1kHz	1:8	20MW

Table 5: 20MW DC-DC converter parameters

3 Results

The control performances of different converters in different situations are presented and discussed in this section. Equation (1) and Equation (2) are the relationships between input voltage and output voltage of DC-DC buck converter in continuous and discontinuous mode respectively, where D is the duty ratio, L is the value of L_2 ($L_1 = 0$) and T is the switching period. The bridge converter is a form of buck converter.

$$\frac{V_{out}}{V_{in}} = D \quad (1)$$

$$\frac{V_{out}}{V_{in}} = \frac{2D}{D + \sqrt{D^2 + \frac{8LI_{out}}{TV_{out}}}} \quad (2)$$

For continuous mode operation:

$$L > \frac{V_o(1-D)}{2I_0f} \quad (3)$$

3.1 Single-phase 5MW DC-DC converter

As mentioned in [7], in Figure 5, adding a small inductor L_1 can help to reduce the value of L_2 and also help to achieve a more regular output waveform and reduce the harmonics. However, for certain values of inductance, the converter may not be easily and accurately controlled by PWM control. Good control is achieved when a change in duty ratio results in a significant change in voltage level. In this section only the voltages of one of the 5MW DC-DC converter will be shown (converter 1) since both the input and output voltages ($V_{dc1} \rightarrow V_{dc4}$, $V_1 \rightarrow V_4$) of these four converters are nearly the same (Figure 3).

- a. When $L_1=0$, $L_2 = 2\mu\text{H}$, input voltage varies from 4892V to 5016V.

The waveform of V_1 (output of the first DC-DC converter in Figure 3) is shown in Figure 7. According to Equation (3), the

converter is working in discontinuous mode. It is apparent that the output voltage does not change significantly when the duty ratio is changed. The input voltage also increases slightly when the switching duty ratio is decreased.

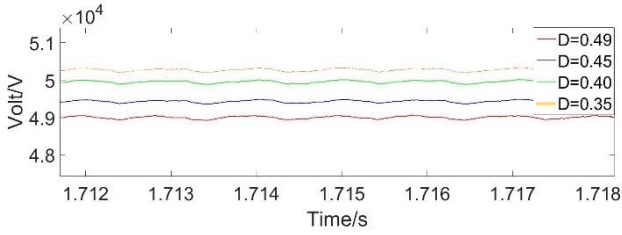

Figure 7: Converter output voltage (V_1) when $L_1 = 0$, $L_2 = 2\mu\text{H}$

b. When $L_1 = 0$, $L_2 = 30\text{mH}$, input voltage varies from 5023 to 5044V.

Generally speaking, it can be very difficult or nearly impossible to have $L_2 = 30\text{mH}$ when the output voltage is about 50 kV; hence this section is used to indicate the performance of DC-DC converter in continuous mode. The results are shown in Figure 8.

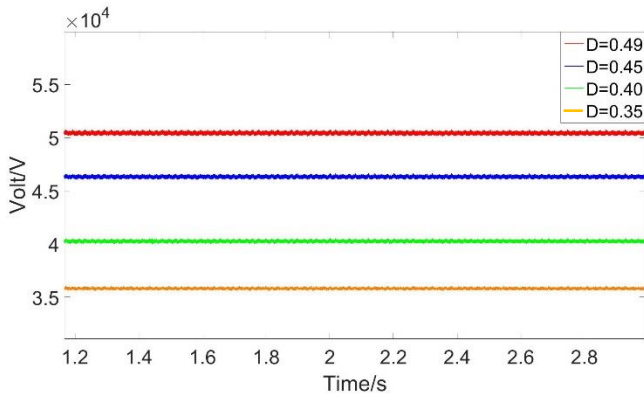

Figure 8: Converter output voltage (V_1) when $L_1 = 0$, $L_2 = 30\text{mH}$

When the bridge converter works in continuous mode (with a relatively ideal transformer), the output voltage can be controlled easily by controlling the duty ratio, and the relationship between V_{in} and V_{out} is identified by Equation (4). Where N_2/N_1 is the turns ratio of the transformer.

$$\frac{V_{out}}{V_{in}} = 2 \frac{N_2}{N_1} D \quad (4)$$

c. When $L_1 = 2\mu\text{H}$, $L_2 \leq 2\mu\text{H}$, input voltage varies from 4944V to 5175V.

In this discontinuous mode case, the value of L_2 can varies from 2nH to 2µH, and the DC voltage levels do not change significantly. This means that having a small inductor at the primary side can help to reduce the value of the inductance at the secondary high voltage side. (L_1 can be either designed as a leakage inductance or as an additional inductive component). Waveforms in Figure 9 indicate that the converter still cannot be controlled effectively in this mode.

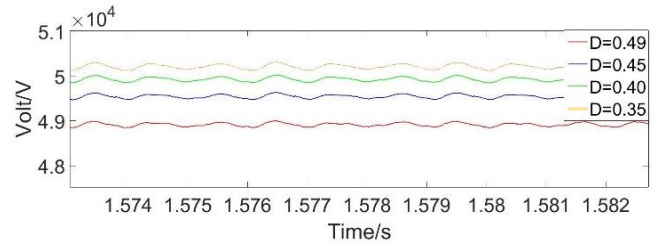

Figure 9: Converter output voltage (V_1) when $L_1 = 2\mu\text{H}$, $L_2 = 2\mu\text{H}$

d. When $L_1 = 200\mu\text{H}$, $L_2 = 2\mu\text{H}$ or smaller, input voltage varies from 5000 to 5010V.

In this case, the converter can be regarded as working in the continuous mode; however, the results show that the value of the output voltage has dropped significantly from the desired value and there is minimal variation in voltage level when the duty ratio is changed. The waveform of V_1 for different duty ratios is shown in Figure 10 below. The results illustrated that the converter cannot reach the desired voltage level in this situation.

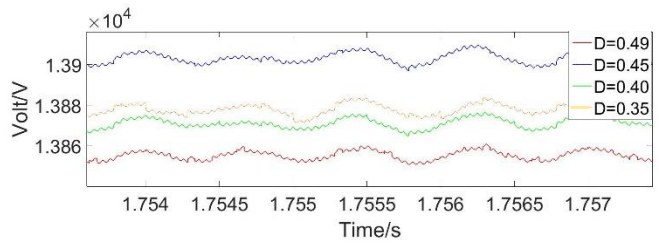

Figure 10: Converter output voltage (V_1) when $L_1 = 200\mu\text{H}$, $L_2 = 2\mu\text{H}$

Figure 11 below demonstrated the structure of IGBT inverter in Figure 5.

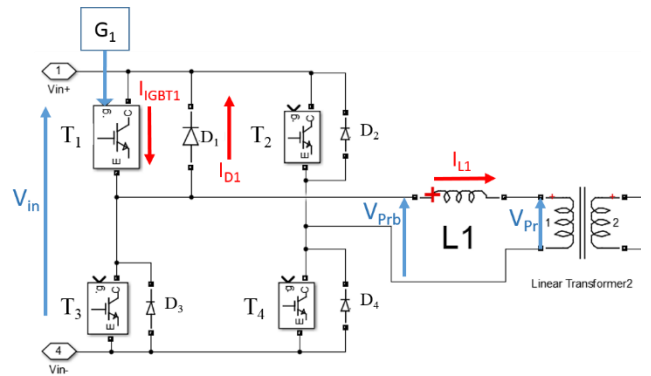

Figure 11: Four IGBT bridge switches of the single-phase DC-DC converter

Figure 12 and Figure 13 show the simulation results of the IGBT gate signal, G_1 , the current flowing through T_1 , I_{IGBT1} , Current through the diode D_1 , I_{D1} , the voltage at the output of the full-bridge, V_{Prb} and the inductor current, I_{L1} for the DC-

DC converter shown in Figure 11 when $D=0.49$ and $D=0.35$ respectively.

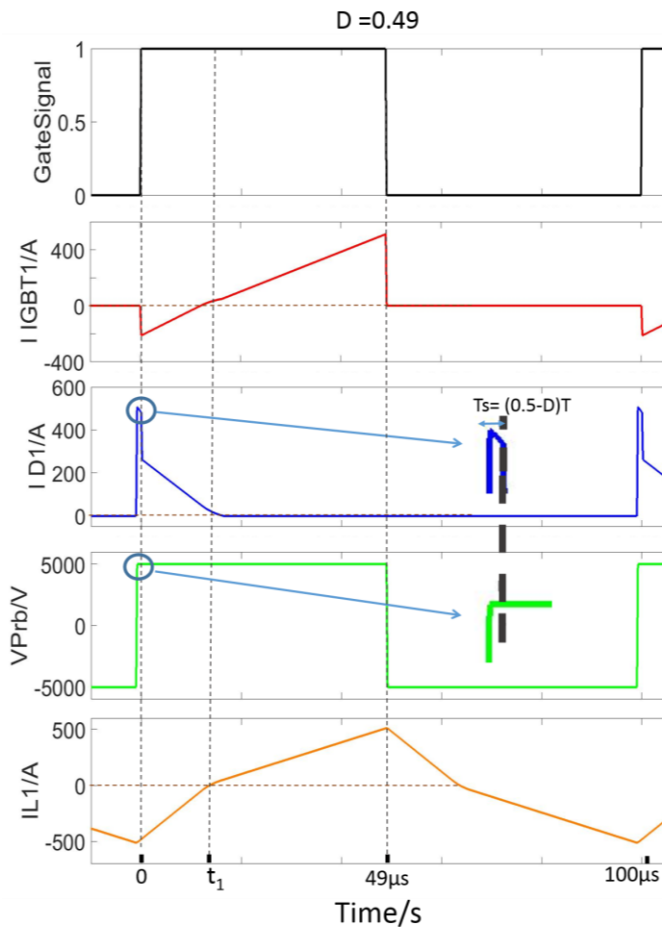

Figure 12: Waveform of G_1 , I_{IGBT1} , I_{D1} , V_{Pr} , I_{L1} when $D = 0.49$

In Figure 12, before $t = 0$, when T_2 and T_3 are just switched off, the current I_{L1} cannot drop to zero immediately, so it continues flowing through D_1 and D_4 until T_1 and T_4 are switched on. This small period is shown in Figure 12 as $T_s = (0.5-D)T$, where T is the switching period. T_1 and T_4 are switched on at $t = 0$, at this time as I_{L1} has not fallen to zero, so half of I_{L1} begins to flow through T_1 and T_4 and another half stays flowing through D_1 and D_4 until $I_{L1} = 0$. From $t = 0$ to $t = t_1$, the power will be transferred back to the DC-DC converter, which means the net transferred power will be reduced as well as the efficiency. The current I_{L1} only increases from t_1 until $49\mu s$ when T_1 and T_4 are switched off.

Figure 13 shows results for the converter operating close to critical continuous mode, and has the same operating principle as when $D = 0.49$ in Figure 12. The only thing that needs to be mentioned is when $D = 0.35$, between t_1 and t_2 , there is visible current circulation from D_1 to T_1 , and this period includes three states:

1. When $I_{D1} > I_{IGBT1}$ and $I_{L1} < 0$, power is transferred back to the previous PWM rectifier.

2. When $I_{D1} = I_{IGBT1}$ and $I_{L1} = 0$, no power is transferred.
3. When $I_{D1} < I_{IGBT1}$ and $I_{L1} > 0$, there is a net power flow to the following three-phase DC-DC converter.

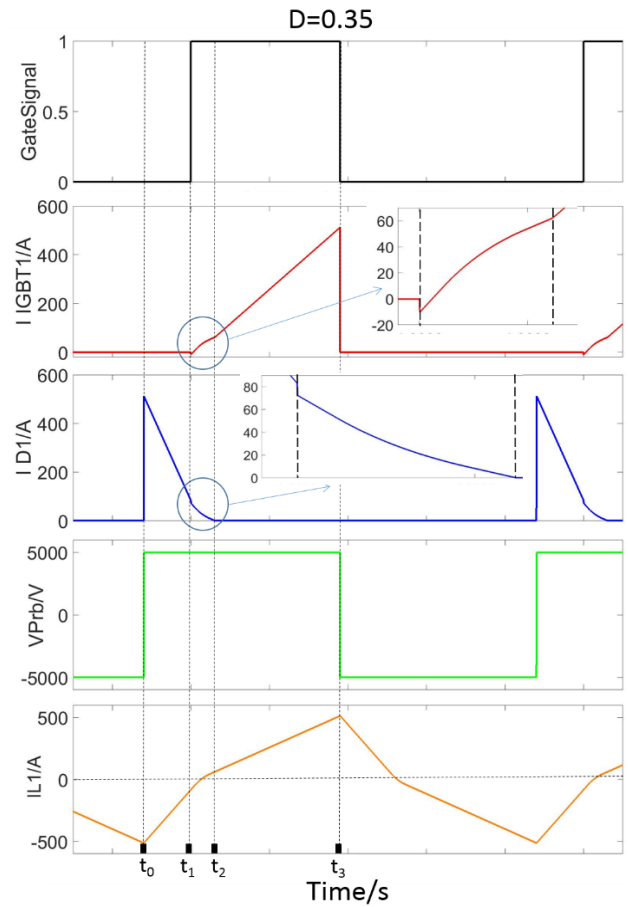

Figure 13: Waveform of G_1 , I_{IGBT1} , I_{D1} , V_{Pr} , I_{L1} when $D = 0.35$

For all the three stages above, circulating current will cause significant losses on both IGBT switches and diodes, especially when $I_{D1} = I_{IGBT1}$.

It is evident from Figure 12 and Figure 13 that the value of the primary side voltage V_{Pr} can be very difficult to be predicted, as the current can flow back to the PWM rectifier when switches are on. The waveform of I_{L1} in Figure 12 can be regarded as the normal secondary inductor current when $D \approx 0.3$ in critical continuous mode rather than 0.49. This explains the reason why V_{out} drops significantly in this situation.

As for the V_{Pr} in any value of duty ratio, it is visible that the waveform only has two states, 5000V or -5000V, and each of the states occupies 50% of the period. The reason is in this "primary continuous mode", during half the cycle, current will continuously flow through the switches or the anti-parallel diodes.

3.2 Three-phase 20MW DC-DC converter

The circuit of the three-phase converter is shown in Figure 6. Compared with the single-phase DC-DC converter, the three-phase converter seems to have a more complex structure, but actually has easier operating states. As for a three-phase DC-DC converter, no matter what the value of the primary/leakage inductor or secondary inductor is, the output voltage can be very difficult to control. This is due to the three-phase structure of the converter. Taking the three-phase diode rectifier as an example, the upper diode in each phase will conduct only when its phase voltage is the highest. This means that the “transferred” output voltage will stay within a narrow “peak range” of the input. This is also the operating principle of the three-phase rectifier. Figure 14 shows the output voltage of the three-phase DC-DC converter, V_{out} , when $D = 0.45$.

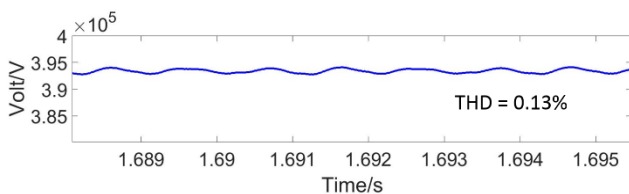

Figure 14: Three-phase DC-DC converter V_{out} when $D = 0.45$

In this simulation, there is no inductor at both the primary side and the secondary side, and the three-phase transformer is also ideal. It is evident from the results that although the three-phase converter can be very difficult to control, it has low ripple and harmonics which can help to reduce the value and physical size of the inductor or capacitor considerably.

4 Conclusion and future work

For the single-phase DC-DC converter in this paper, four different situations are discussed, with case c as the most suitable ($L_1 = 2\mu\text{H}$ and $L_2 \leq 2\mu\text{H}$). The result indicates that this kind of converter cannot be controlled easily when working in a high voltage high power system. It can be seen from Equation (3) that the higher the switching frequency, the lower the value of L_2 is required in case b (When $L_1 = 0$ and $L_2 = 30\text{mH}$). However, for a 5MW, 5kV-50kV converter, the maximum switching frequency is about 10kHz. As for the converter case d, if the converter structure can be modified, it may can be controlled easily and accurately, hence may be regarded as the DC-DC converter with the most potential.

For the three-phase DC-DC converter, although it cannot be controlled properly, its low ripple/harmonic characteristic is still very valuable in a high power/high voltage system. One possible enhanced structure for the 20MW converter is the use of the input parallel output series (IPOS) converter circuit, which takes the advantages of both an easily controllable converter and three-phase DC-DC converters.

At this stage, for a multi-terminal HVDC system illustrated in Figure 2 and Figure 3, we can control the output of the single-phase DC-DC converter case c by controlling the output of

the previous PWM block, which is the input of the single-phase DC-DC converter.

For the 20MW converter, the IPOS structure can be adopted, and more future work will concentrate on the research of this type of converter.

References

- [1] “Environmental Impact of Wind Power” *Science for a healthy planet and safer world*. Online at: http://www.ucsusa.org/clean_energy/our-energy-choices/renewable-energy/environmental-impacts-wind-power.html#bf-toc-2
- [2] G. Johnson, “Wind Energy System” *Manhattan: Kansas State University*, 2006, pp.1-1 - 1-4
- [3] L. Y. Pao and K. E. Johnson, “Control of wind turbines,” *IEEE Contr. Syst. Mag.*, vol. 31, no. 2, Apr. 2011, pp. 44–62
- [4] M. Baradar, M. R. Hesamzadeh, M. Ghandhari, “Modelling of Multi-Terminal HVDC Systems in Optimal Power Flow Formulation” *IEEE Electrical Power and Energy Conference (EPEC)*, London, UK, 2012.
- [5] T. J. Hammons, D. Woodford, J. Loughtan, M. Chamia, J. Donahoe, D. Povh, B. Bisewski, and W. Long, “Role of HVDC transmission in future energy development,” *IEEE Power Eng. Rev.*, vol. 20, no. 2, Feb. 2000, pp. 10–25
- [6] X. Rong, C. Shao, “Analysis on the Operation of 750kV Controllable Shunt Reactor in Gansu Power Grid of China” *2nd International Conference on Smart Grid and Green IT Systems*, Aachen, Germany, 2013.
- [7] X. Rong, D. E. Macpherson, “The Effect of Converter Harmonics In Offshore High Voltage and Medium Voltage DC Networks” *IEEE 50th International Universities Power Engineering Conference (UPEC)*, Staffordshire, UK, 2015.
- [8] Y. Zhang, M. Zhou, “Wind Power Price Regulation Considering Wind Power Fluctuation” *5th International Conference on Critical Infrastructure*, Beijing, China, 2010.