

# MACHINE TO MACHINE COMMUNICATION FOR HEALTH CARE AND DISASTER MANAGEMENT

Thesis submitted in partial fulfillment of the requirements for the degree of

**Bachelor of Technology**  
**In**  
**Electronics and communication Engineering**  
**By**

Dikshya Shree Rath

111EC0154

Under the supervision of  
Prof. Shrishailayya Mallikarjunayya Hiremath



**Department of Electronics and Communication Engineering**  
**National Institute of Technology, Rourkela**

---

# CERTIFICATE

This is to declare that the work presented in the thesis entitled "*Machine to Machine Communication for health and disaster Management*" is a bonafide record of the research work done by Dikshya Shree Rath, 111EC0154 under the supervision of Prof. Shrishaillya Mallikarjunaya Hiremath, Department of Electronics & Communication Engineering, National Institute of Technology, Rourkela, India and that this thesis work has not been presented for the award of any other degree.

Prof. S.M. Hiremath  
Department of Electronics & Communication  
NIT Rourkela  
Project Supervisor

# ACKNOWLEDGEMENT

Firstly, I would like to express our deep sense of respect and gratitude towards my advisor and guide **Prof. Shrishailayya Mallikarjunayya Hiremath**, who has been the guiding force behind this work. I want to thank him for introducing me to the field of Communication Engineering and giving me the opportunity to work under him. It is my good fortune to have got an opportunity to work under such a wonderful person. I sincerely appreciate his inspiration; support and guidance. He has been instrumental in making this project a success.

I would also like to thank **Prof Sarat Kumar Patra** for letting me use his well - equipped laboratory at any time of the day and **Pallab Maji** Sir for his able guidance and making me acquainted with the facts and features about M2M and Raspberry Pi.

We also express our sincere gratitude to **Prof Kamalakanta Mahapatra**, Head of Department, Electronics and Communication Engineering for allowing access to all valuable facilities which were a necessity for us. We would also like to convey our gratitude to all the research scholars in our department who assisted us during the completion of this project work and their well-timed and valuable guidance that helped us to finish the work in the predetermined period of time.

Our thanks and appreciations also go to our friends and batch mates in developing the project and people who have willingly helped us out with their abilities.

# ABSTRACT

Machine to Machine communication for health and disaster management aims to develop a software module that will take data from the pulse or heart rate and temperature of a human being. The two machines involved here are a Raspberry pi and the own Personal Computer of the patient. The measured data is sent to one monitoring device via LAN as digital data and the samples will be analysed for a threshold level. If it exceeds it then person will not be allowed to drive the vehicle for these results will be compared with the parameters of a human body after alcohol consumption. This incorporates medical and disaster applications both. The video conferencing module is added so as to provide a direct communication between patient and health care professional. The data can be sent to medical professionals at the back end and the person can be warned of the health hazards as well as incorporating this will regulate and reduce the number of road accidents that take place due to reckless and drunk driving .

# Table of Contents

Certificate.....	ii
Acknowledgement.....	iii
Abstract.....	iv
Table of figures.....	1
List of Acronyms.....	2
<b>Chapter 1: Introduction</b> .....	<b>3</b>
1.1 INTRODUCTION TO M2M .....	4
1.2 ARCHITECTURE AND COMPONENTS OF M2M.....	5
1.3 CONCERNS AND ISSUES OF M2M .....	6
1.4 APPLICATIONS OF M2M COMMUNICATION .....	7
Chapter 2 Literature Review .....	9
2.1 LITERATURE REVIEW .....	10
Chapter 3 Implementation of Temperature and Heartbeat sensing on Raspberry Pi ....	13
3.1 RASPBERRY PI.....	14
3.1.1 MEMORY.....	15
3.1.2 CONNECTIONS .....	15
3.1.3 HDMI .....	15
3.1.4 PROCESSOR.....	15
3.1.5 GPU .....	15
3.1.6 Operating Temperature Range.....	15
3.2 SIMULINK .....	17
3.3 COMPONENTS USED .....	18
3.3.1 DHT11 .....	18
3.3.2 LM324D.....	19
3.4 IMPLEMENTATION .....	20
3.5 TECHNIQUES USED .....	23

3.6 PROCEDURE .....	23
Chapter 4: Results and Analysis .....	26
4.1 RESULTS AND ANALYSIS .....	27
Chapter 5 Conclusion and future work. ....	33
5.1 CONCLUSION .....	34
5.2 SCOPE FOR FUTURE WORK .....	34
References .....	35

# Table of Figures

Figure 1- 1 High Level Architecture for M2M.....	4
Figure 1 - 2 Pictorial representation for M2M .....	6
Figure 2- 1 Internet of Things Vision .....	10
Figure 2- 2 Heart beat sensor.....	11
Figure 2- 3 Comparison of Conventional system and M2M system [5].....	12
Figure 3 -1 Raspberry Pi schematic diagram .....	14
Figure 3 -2 Raspberry Pi board .....	14
Figure 3- 3 Raspberry Pi pin configuration.....	16
Figure 3- 4 DHT11 sensor .....	18
Figure 3- 5 DHT11 connections with Raspberry Pi .....	19
Figure 3 -6 LM324D pin connections as seen from top .....	19
Figure 3-7 Write to a Raspberry Pi GPIO pin .....	21
Figure 3- 8 Read from and write to a Raspberry Pi GPIO pin .....	21
Figure 3 9 Simulink model for temperature sensing with camera module .....	22
Figure 3-10 Hardware set up for temperature sensing and camera module. ....	22
Figure 3- 11 Hardware set up for the pulse rate measurement .....	23
Figure 3-12 Simulink model for the pulse measurement .....	24
Figure 3 -13 Maximum and 80% heart rate according to age.....	24
Figure 3-14 Simulink model for temperature sensing, pulse rate and the video conferencing .....	25
Figure 3-15 Hardware set up for temperature sensing, pulse rate and the video conferencing. ....	25
Figure 4-1 GPIO output .....	27
Figure 4-2 GPIO input and output.....	27
Figure 4- 3 Time and temperature signals .....	28
Figure 4 4 Temperature Graph.....	29
Figure 4 5 Pulse rate graph .....	29
Figure 4 - 6 Pulse rate graph 2 .....	30
Figure 4-7 Graph plotted between time and signal values .....	30
Figure 4 - 8 combined graph of temperature and pulse.....	31
Figure 4 9 Facial Snapshot using camera module .....	31
Figure 4 - 10 Model displaying the heart rate in display block .....	32
Figure 4 - 11 Simulation finished.....	32

## List of Acronyms

- M2M- Machine to Machine
- GPIO- General Purpose input output
- BPM- Beats per minute
- IP- Internet Protocol
- RAM- Random Access Memory
- IoT- Internet of Things
- HDMI- High-Definition Multimedia Interface
- GPU- Graphics Processing Unit
- PPG-Photoplethysmography
- QoS- Quality of Service



# Chapter 1: Introduction

This chapter deals with general over view of the project along with aim and objective of the investigation

# 1.1 INTRODUCTION TO M2M

Machine to Machine (M2M) refers to those technologies that allow both wired and wireless systems to interact with other devices of the same type. M2M uses a sensing-metering device to capture signals like temperature, inventory level, that are relayed through a wired or wireless or hybrid network to a software application that translates the captured event into meaningful information. Machine-to- M2M communication is a form of interaction with data that involves one or more parameters which do not necessarily require human intervention in the process of communication. [1]

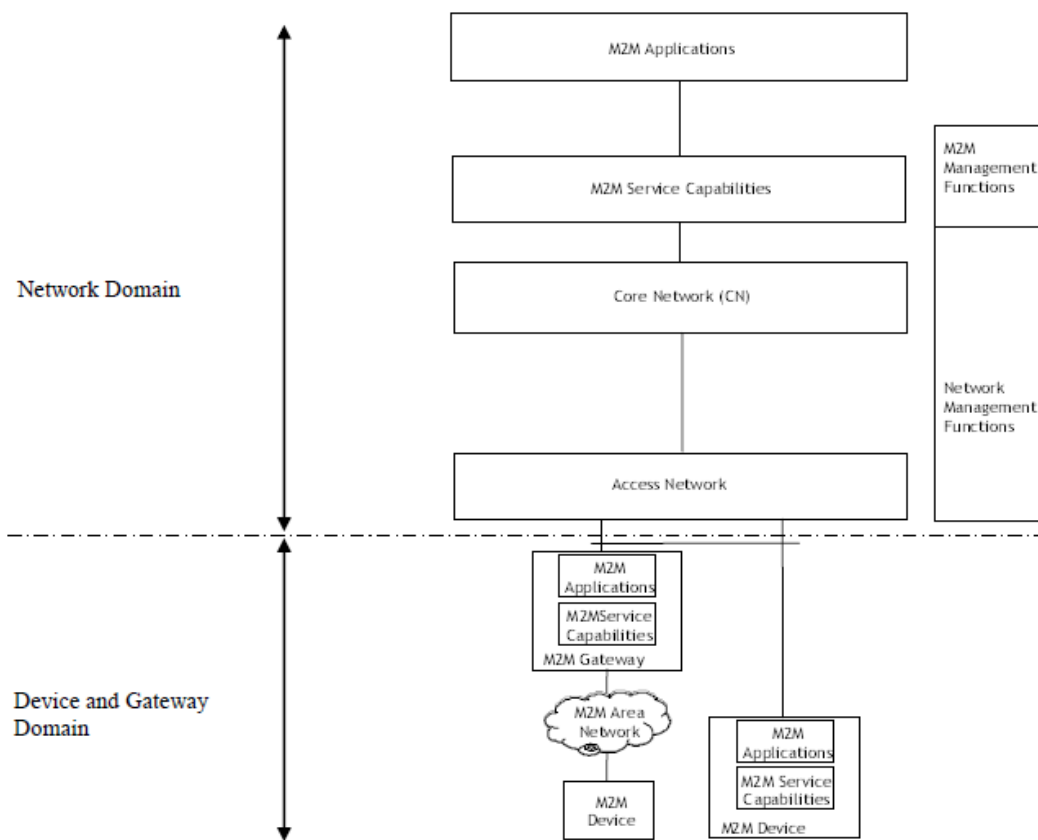

Figure 1- 1 High Level Architecture for M2M

The tremendous advances in the field of information and communication technologies gave rise to one of the most important applications of M2M and that is healthcare management. With medicinal services migrating from a method dedicated to monitoring

of reactions to intense environment to prompt detection, aggressive action, and conveyance of well-being conditions. Observation and monitoring of health conditions is of utmost importance especially vital in modern nations with an ever rising population, where big data engineering can be used to administer the conditions and derive personal satisfaction. [2]

## 1.2 ARCHITECTURE AND COMPONENTS OF M2M

Figure 1- 1 shows a simple architecture of M2M systems with its components. The various components and elements of an M2M system are briefly described below:

**a. M2M Device:** It is a device that can accept the appeal for data transmission within other connected devices. Sensors and communication devices serve as destination for M2M applications. The connection is usually done through Bluetooth, Zigbee where everything is connected via the gateways. Addressing, routing is heavily dependent on M2M gateways. Devices that get connected through the gateways are not the operator's responsibility but belong to M2M applications that are supplied by service as well as application providers. Thus the liability of the information and connections lies on the network operator also known as virtual network operator. This holds true especially with respect to TPM where ensuring that the module is really that reliable and well protected is of high importance. [3]

**b. M2M Area Network (Device Domain):** The area network being the backbone provides interconnection between the M2M devices and gateways.

**c. M2M Gateway:** Gateways are equipments which uses M2M capabilities to make sure that M2M Devices are interconnected communication network. Gateways and routers serve as the destination for the operator's network where the sensors and M2M devices fail to connect to the network. Thus, the gateways and routers serve two functions. Firstly, they make certain that the devices in the network are reachable from outside and vice versa. The access enablers carry out the identification, addressing, accounting functions, from the operator's convenience and need to be supported at the gateway's side also.

Thus the platform-gateway distributed system in which generic and abstract capabilities are implemented on the gateway's side and a control flow between gateway and platform of operator that has to be distinguished from the data channel which transfers M2M application data. Secondly the need for mapping of bulky internet protocols to their lightweight analogues in low-power sensor networks is also provided by this. However, the latter application loses its weight owing to usage of IPv6 for sensor networks which provide an all-IP approach. [3]

**D.M2M Communication Networks (Network Domain):** It provides the communication between the M2M Gateway(s) and M2M application(s), e.g. xDSL, LTE, WiMAX, and WLAN

**e. M2M Applications:** The M2M applications act as the middle layer where the data is filtered by application services and engines which monitor the business process. It is based on infrastructure and architecture as provided by the operator. It targets the users to provide the necessary solutions with sophisticated and elaborate functionality. The design and implementation might be offered by the operator platform itself.

### 1.3 CONCERNS AND ISSUES OF M2M

Addressing and security form the basis of key concerns in M2M functionality. The M2M system needs to be flexible to allow the reuse of names of the operating devices in the environment and should support identification of connected or groups of connected objects by their mask addresses, names and gateways (e.g. URIs or IMSI). The addressing schemes should include:

- IP address of all the connected objects in the domain.
- IP address of group of connected objects (including multicast address).
- E.164 addresses of connected objects (e.g. MSISDN).

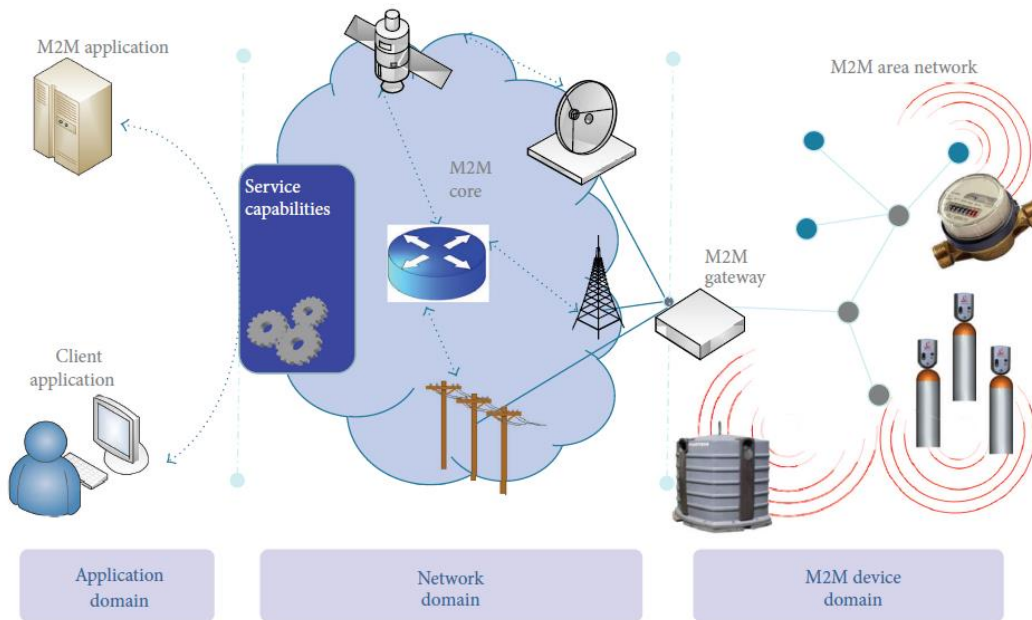

Figure 1 - 2 Pictorial representation for M2M

M2M devices often remain unguarded thus making them vulnerable to security threats like monitoring by unauthorized access and tampering with data transmission. Therefore adequate security plans need to be implemented to save them from such malicious attacks. It is likely for M2M devices to increase in numbers in near future and thus making it tough or nearly impossible for operators and subscribers to manage or service them. Hence remote management and firmware updates need to be incorporated and fault recovery system should be a robust one.

## 1.4 APPLICATIONS OF M2M COMMUNICATION

- **Traffic control systems:** Traffic control is an area of concern that demands attention and can be sorted out with help from M2M communications. Sensors and traffic control equipments can be programmed to serve like the conventional traffic system without human intervention and can be used to monitor the vehicles for accidents and thus fulfilling the goal of safety.
- **E-Healthcare systems:** Improving the channel of communication between health care specialists and patients will help in expanding the perceptual ability, cooperation thus minimising the medical services cost. The ratio of nurses to patient's decreases day by day thus making the constant testing and report analysis a hectic job. So M2M can be used to provide an alarm to indicate the unusual well-being conditions and ailments and enhancing the life of the patients.
- **Disaster Management:** Disaster mitigation can also be achieved through M2M applications while benefiting the quality of work and personal life tremendously.

## 1.5 OVERVIEW OF THE THESIS

**Chapter 2** deals with the description of M2M and its applications. It also includes the detailed study of the various research carried out on a similar base. It also helps in getting insight and provides motivation to carry out the project and establishes the genuineness of work carried out in this thesis by providing a comprehensive analysis of the past work.

**Chapter 3** being the most integral chapter provides us with all the information that is required to understand the project. It includes the design methodologies, components used- pin description of IC and their features suitable which helped me chose this for carrying out the work, the software used- description and features. All the circuit diagrams and hardware set up along with the steps required to carry out the project is also discussed in detail.

**Chapter 4** deals with the results and their analysis. Each graph, plot and snapshot of output on hardware is clearly explained along with the required calculations if necessary. This helps in understanding the results and how close we got to achieve the output.

**Chapter 5** deals with the conclusion of results and the future scope of the project. It also consists of the discussion and conclusion derived from the simulations and hardware output. It also provides us with few suggestions on how things could have been improved in the project and what more could have been incorporated in order to make it a better success.

## Chapter 2 Literature Review

This chapter explains the fundamental aspects of Machine to Machine Communication as well as summarizes published literature and articles related to its necessity and application

## 2.1 LITERATURE REVIEW

Communication is that the act of exchanging ideas, data and opinion. It is generally classified as human to human communication, human to machine communication, machine to human communication and machine to machine to communication. The IoT vision is to target 20million M2M devices by year 2020.

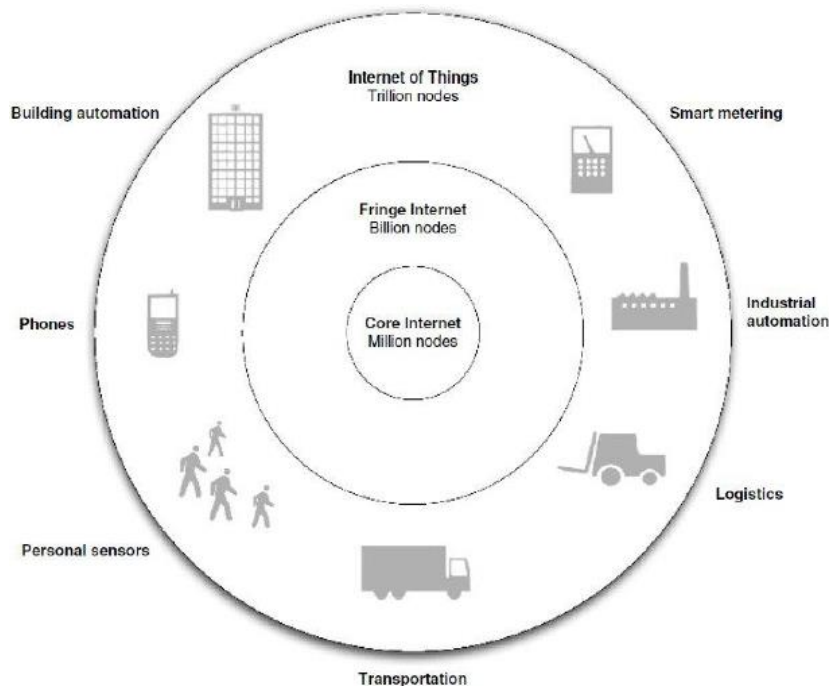

Figure 2- 1 Internet of Things Vision

The advancement of wireless communications and technologies have had a significant impact on our daily lives. People can exchange any form of data at any time and situation with ease. M2M targets on low human intervention which requires self organisation, configuration, management and robustness. M2M networks can be utilized in many fields like agriculture, healthcare, transport industry, electricity grids etc. For this machines need to be portable, of small size, reliable and efficient and should not require high maintenance to be deployed in various sectors.

The continuous monitoring of signals from biomedical indicators are highly necessary for diagnosis and treatment of ailments. The ECG or PPG sensor can be worn and gives us a perspective of the state of the patient. M2M aims at providing innovations that permit both wired and wireless frameworks to communicate with each other thus providing internetworking and designing an ideal model for predominant communication with an



insightful association of machines in good sense. Interpreting data and analyzing them for required results with usage of modern instrumentation and communication techniques is the basic aim for M2M. The whole processed data needs to have a focal center for it to be investigated. The explosion of IP networks and migration to Ipv6 framework has made it very simple for M2M to happen and provides better connectivity. This is gaining impetus and will turn up for huge profits in future where human interaction can be lessened to a great extent. The rapid advancement is an ardent proof of hidden opportunities in M2M administrations while opening huge permits for business clusters. [2]

In [5] the aspects of procuring physiological Parameters like SPO2, airflow (breathing), heartbeat, body temperature, blood pressure, of the patient and then analyzing the gathered information, sending it wirelessly using any one of the of the connectivity options like Bluetooth, 802.15.4, ZigBee, Wi-Fi, 3G and GPRS depending on the application are discussed properly.

The various physical parameters used along with the flexibility of using a camera module provides enough inspiration to carry on some further work on a different Microcontroller, which I implemented using Raspberry Pi and using temperature and pulse as the parameters along with the camera.

The M2M devices can be modelled to measure and transmit the signals from the PPG sensor. The heartbeat and saturated oxygen concentration data can be calculated by that Infra-red sensor, the detailed procedure is explained later in chapter 3. The LED, potentiometer, filter and the ADC are the essential components that help to acquire the required signal. Signal conditioning and processing is needed to study the weak feeble signal obtained. The low pass filter removes the noise and the band pass signals rejects the DC component. The modes and gateways help in transmission and reception of data. The above analysis and proposal is what explains and gives out an insight of an PPG sensor and how it works thus inspiring to incorporate the same in my project but with a different procedure of measuring and analyzing the signals.



Figure 2- 2 Heart beat sensor

The service providers are instrumental in providing the infrastructure and equipment for the network, like Cisco has developed the smallest router known which helps in paving a way for the M2M applications through an efficient gateway. [4]

The American and European countries have shown a significant growth in the development of M2m networks whereas few developing countries have not been able to be at par with them, this is mostly due to the lack of 3G which primarily serves as the backbone and facilitates connectivity. [4]

BodyTel and Continua Health Alliance target on achieving a functional health ecosystem that strives for interoperability among solutions from various companies. SSL encryption and storing data in cloud are most important aspects that need to be considered security wise which prevents data from getting hacked. Complying with national and international health guidelines is also necessary in health care industry thus incorporating this in M2M is crucial.

<b>Features</b>	<b>Conventional System</b>	<b>M2M based System</b>
Operation	Fixed type of operation	Variable Operation
Capacity	Difficult to vary and rearrange facility	Easy to vary & rearrange facility
Cost	High cost	Low cost
Flexibility	Fixed capacity for pollution facilities	Flexible capacity for pollution facilities
Efficiency	Manual capture system hence Low Efficiency	Wired /Wireless Integrated system hence High Efficiency

Figure 2- 3 Comparison of Conventional system and M2M system [5]

The ETSI TC M2M has defined a set of standardized service capabilities that can be very easily implemented in a M2M platform via nodes and gateways. The design of low power and low cost sensors that too portable and robust is the new demand of the time. [6]

The efficient addressing mechanism of IPv6 over IEEE 802.15.4 protocol allows M2M to establish the sensor networks and provide healthcare service coverage .With the progress in mobile communication opens up an era of opportunities for developing a health care system which can be used to remotely monitor the biomedical signals from the patients by using networks like 3G, Bluetooth, WCDMA, GSM etc. The person is not entitled to go to hospital every time for a checkup, the results can be directly sent to him thus making daily life easier. With the evolution of android phones, IPv6 techniques can be used to design a health care system. The same PPG signals can be transmitted and get collected in a server PC and the analysed report is sent back to the android user on the cell phone. [5]

## Chapter 3 Implementation of Temperature and Heartbeat sensing on Raspberry Pi

This chapter includes the procedure, components used and the techniques used to obtain the results. It provides the schematic diagrams and the hardware set ups required.

### 3.1 RASPBERRY PI

The Raspberry Pi is a computer of the size of a credit-card that can easily plug into a TV or a keyboard. It is a competent little computer with versatile functions which can be used in electronics projects, to replace a lot of things that can be done by the Personal computer, like spreadsheets and word-processing and playing video games. It also supports high-definition video. [7]

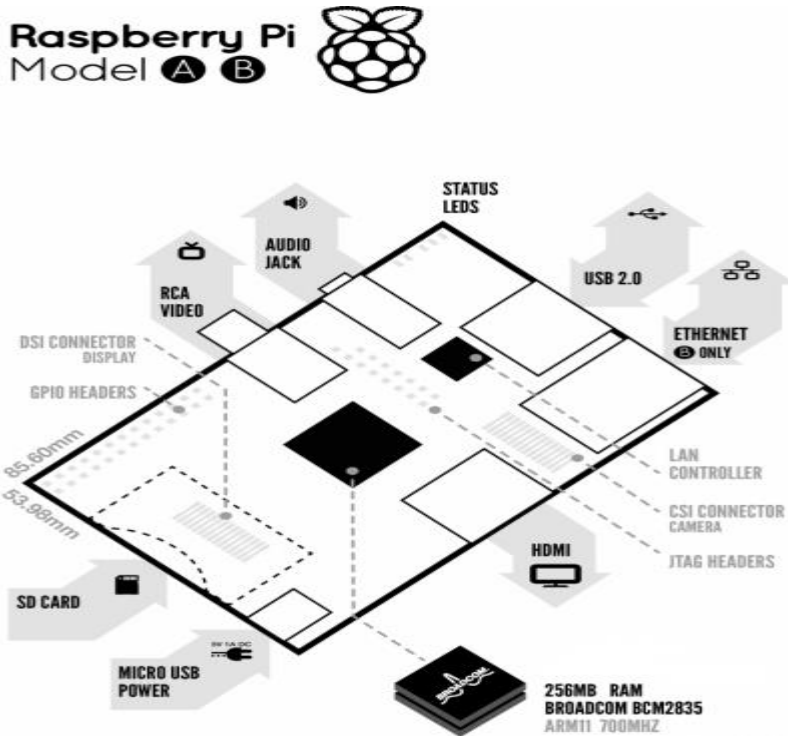

Figure 3 -1 Raspberry Pi schematic diagram



Figure 3 -2 Raspberry Pi board

### 3.1.1 MEMORY

512MB RAM [7]

### 3.1.2 CONNECTIONS

- 2 USB ports
- Ethernet port
- 3.5mm jack for audio out [7]

### 3.1.3 HDMI

Composite Video [7]

### 3.1.4 PROCESSOR

SoC is a Broadcom BCM2835. This comprises an ARM1176JZFS (ARM11 using an ARMv6-architecture core) with floating point, running at 700Mhz, and a Video core 4 GPU. [7]

### 3.1.5 GPU

- The first version of the GPU used came out in 2009.
- Capable of Blu-ray quality playback, using H.264 at 40Mbits/s.
- Has a fast 3D core accessed using the supplied OpenGL ES2.0 and OpenVG libraries.
- Provides Open GL ES 2.0, hardware-accelerated OpenVG, and 1080p30 H.264 high-profile decode.
- Capable of 1Gpixel/s, 1.5Gtexel/s or 24 GFLOPs of general purpose compute and features a bunch of texture filtering and DMA infrastructure.
- That is, graphics capabilities are roughly equivalent to Xbox 1 level of performance.
- Overall real world performance is something like a 300MHz Pentium 2, only with much, much swankier graphics. [7]

### 3.1.6 Operating Temperature Range

- The LAN9512 (USB and Ethernet IC) is specified as 0°C to 70°C (the commercial temperature range part is used on the RPi – part number is "LAN9512-JZX", not "LAN9512i-JZX" indicating industrial temperature range)

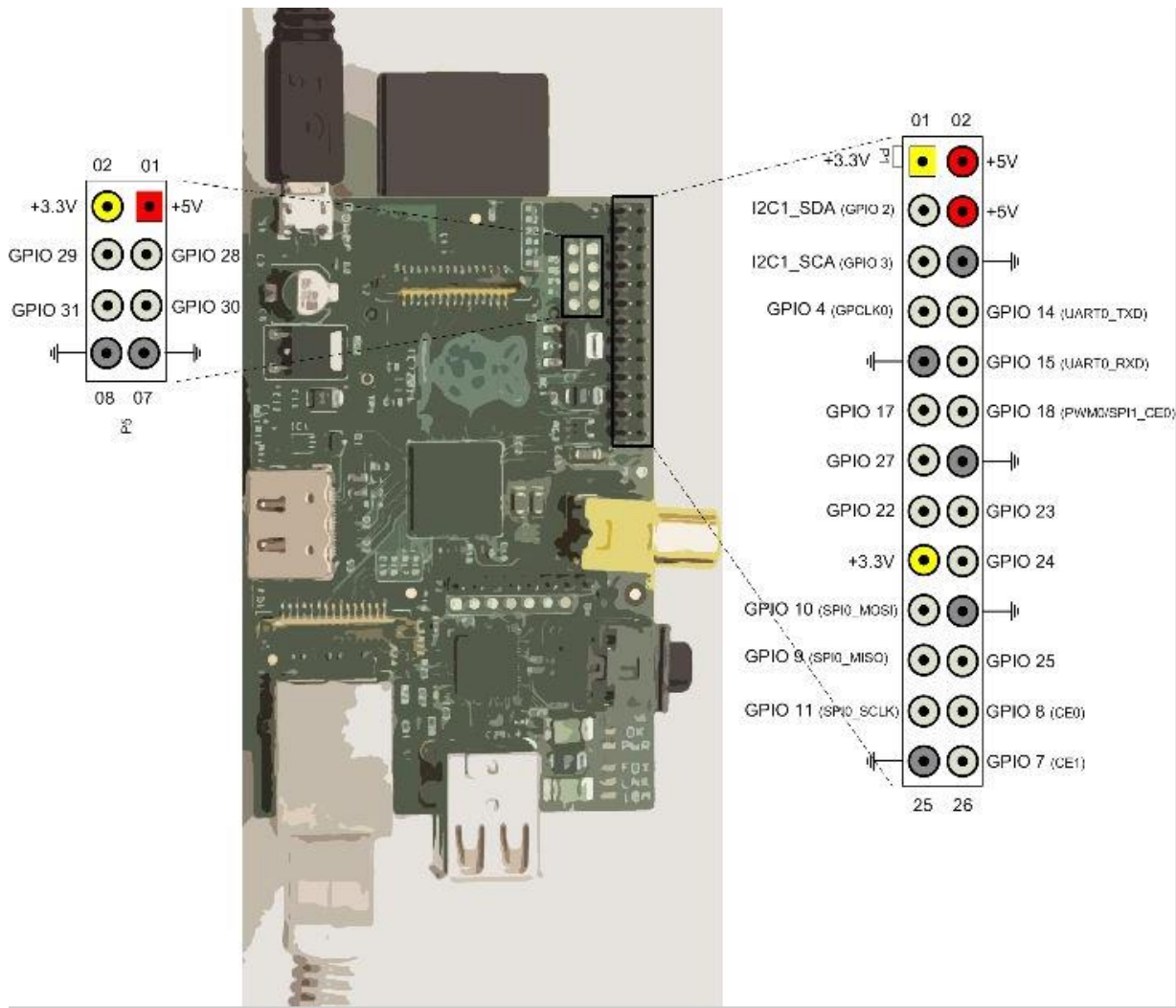

Figure 3- 3 Raspberry Pi pin configuration

Revision 2.0 Board (Model A & Model B) labels are:

- ACT
- PWR
- FDX
- LNK
- 100

The LEDs have the following meanings:

- ACT – D5 (Green) – SD Card Access

- PWR – D6 (Red) – 3.3 V Power is present
- FDX – D7 (Green) – Full Duplex (LAN) connected
- LNK – D8(Green) – Link/Activity (LAN)
- 100 – D9(Yellow) – 100Mbit (LAN) connected

## 3.2 SIMULINK

Simulink, developed by MathWorks. It is basically comprises of data flow graphical programming language blocks for modeling, simulating and analyzing dynamic systems. Its essential feature are graphical block tools and a set of functions that can be altered according the user's needs. It works in close integration with the MATLAB environment and can either run MATLAB or be concluded from it. Simulink is widely used in control systems and digital signal processing applications for simulation in many domain systems and provides Model-Based Design. Simulink along with State flow models in real-time environment supports specific embedded targets. When used with other generic tools, Simulink and State flow can automatically generate ready to use VHDL and Verilog codes.

Simulink confirmation and acceptance enables a detailed processing of models through checking of styles, tracing of requirements and the coverage factor analysis. Simulink Design Verifier uses very formal methods to check for errors in design like integer overflow, zero division and dead logic, and generates test case scenes for checking of the model amidst the Simulink environment.

The methodical testing tool TPT is marketed as a way to perform a proper checking and correction practice to activate the Simulink blocks and also during the development segment where the developer generates inputs to test the system. By the exchange of the Constant and Signal generator blocks of Simulink, it is possible to make the stimulation consistent.

SimEvents is used to incorporate building blocks (graphical) for modeling real time systems, and to merge event-based simulation engine and time-based simulation engines in Simulink environment.

Simulink is also used to spontaneously generate C source code for real-time implementation of systems. As the efficacy and flexibility of the code gets better, Simulink is widely approved for production systems application, being a tool for

embedded system design work owing to its ability for rapid repetition. Embedded Coder feature creates codes that are robust and efficient for embedded systems.

### 3.3 COMPONENTS USED

#### 3.3.1 DHT11

DHT11 is an advanced digital temperature and humidity sensor which yields an adjusted computerized sign of the measured parameters. The sensor includes a resistive feeling of wet components and a NTC temperature estimator joined with an exclusive 8-bit microcontroller. [8]

- Operating voltage: 3-5V;
- Humidity: 20%-80%, 5% precision;
- Temperature: 0° to 50°C, ±2°C precision.

Ease, relative dampness, long haul strength and temperature estimation, amazing quality, strong impedance capacity, spontaneous reaction, meticulous calibration and long separation signal transmission, are its features. [8]

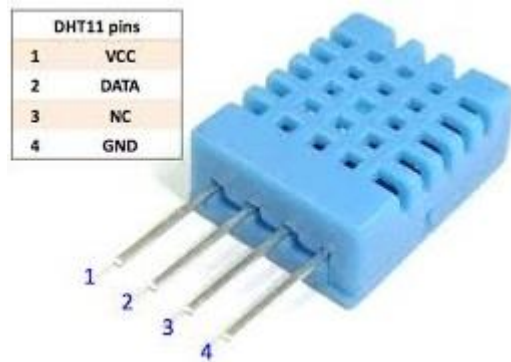

Figure 3- 4 DHT11 sensor



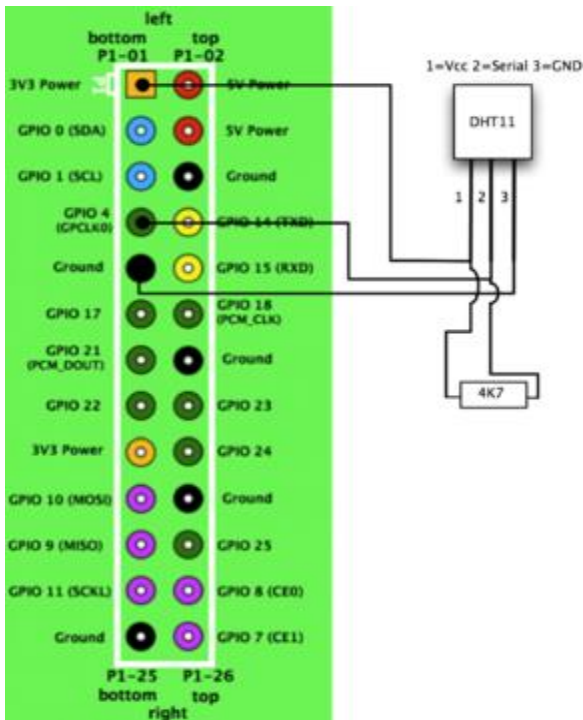

Figure 3- 5 DHT11 connections with Raspberry Pi

### 3.3.2 LM324D

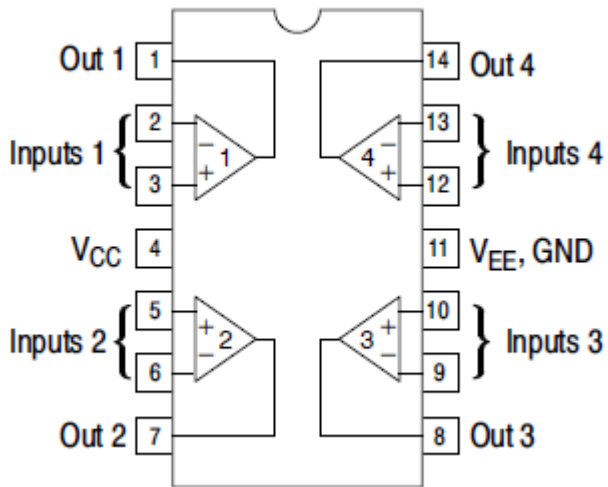

Figure 3 -6 LM324D pin connections as seen from top

The LM324 series are affordable, quad opamp which operate on differential inputs and have enormous advantages over the conventional operational amplifiers. They have an operating voltage range of 3 to 32 V and there is no requirement of external biasing once the input voltage falls in the range of common mode voltage range that includes the negative supply too. The output voltage range also incorporates the negative power supply voltage.

### Features [9]

- Short Circuited Protected Outputs
- True Differential Input Stage
- Voltage within 3.0 V to 32 V and current as low as 100 nA Maximum (LM324A)
- Four Amplifiers in one Package
- Common mode range prolongs to negative supply
- Industry Standard output pins with ESD Clamps that increase sharpness without altering the device Operation
- NCV Prefix provides automotive applications needing exclusive control Change
- These Devices are Lead and Halogen Free and are RoHS Obedient. [9]

## 3.4 IMPLEMENTATION

- Installation of support packages for Raspberry Pi in Simulink.
  - Locate the installed compiler.
  - Install the support packages needed by using the support package installer that comes with MathWorks.
  - It requires a MathWorks log in and a SD card to burn the Raspbian wheezy onto it.
- Configuring the Raspberry Pi to the Electronics Department Internet Network.  
Manually enter the network settings like IP address,
  - Host name,
  - Password,
  - Default gateway,
  - Network mask.
- Running the image inversion algorithm in Raspberry Pi.
  - Plug in USB Ethernet adapter into PC and adapter to the Raspberry Pi.
  - Plug in USB webcam into raspberry Pi.
  - Insert SD card into Raspberry Pi.
  - Attach USB power cable- USB A to PC and B to power port on Raspberry Pi.

- Ping raspberry Pi from Matlab command Window  
Syntax: - !ping (IP address) the IP address in this case for the raspberry Pi is 192.168.51.200
- Open the raspberry pi inversion model
- Select the configuration parameters in tools
- Run on target hardware- Raspberry Pi
- Enter the necessary information and click on apply just to make sure everything is configured correctly.

- There are two ways of running the model :-
  - **Deploy to Hardware**- If we do not wish to interact with the application that is running on the raspberry pi.
  - **External mode**- When we wish to interact with the application and give commands whilst it is running.
- Took output from the GPIO (General purpose Input output) pin and checked the voltage and glowed a LED.

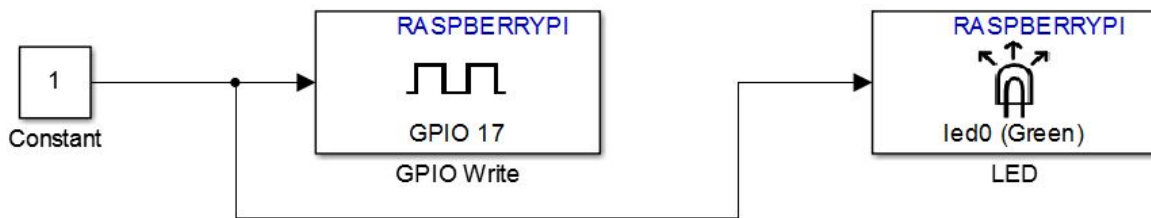

Figure 3-7 Write to a Raspberry Pi GPIO pin

- Gave input to the GPIO pins via a button and tried to check the output of another pin.



Figure 3- 8 Read from and write to a Raspberry Pi GPIO pin

- Measured the body temperature (hands and neck) using DHT11 sensor and dumped Simulink model on Raspberry Pi and logged the signals and drew the graph.
  - The Gpio read block had the 4<sup>th</sup> pin connected to it.

- The data pin of the sensor is connected on the breadboard. A pull up resistor of 4.7k or 10k is used between the Vcc and data pin of the DHT11 sensor.
- The ‘to workspace’ variable creates an array and saves the data from GPIO read block. It has 3 parts- signals, time values, and values.
- The scope block is used to see the graph for the temperature variations vs time.
- The display block displays the data from the read pin- 1 Or 0. A transition refers to change in temperature.
- While setting configuration parameters the sample time selected for GPIO as well as in the “to workspace” block must be same.

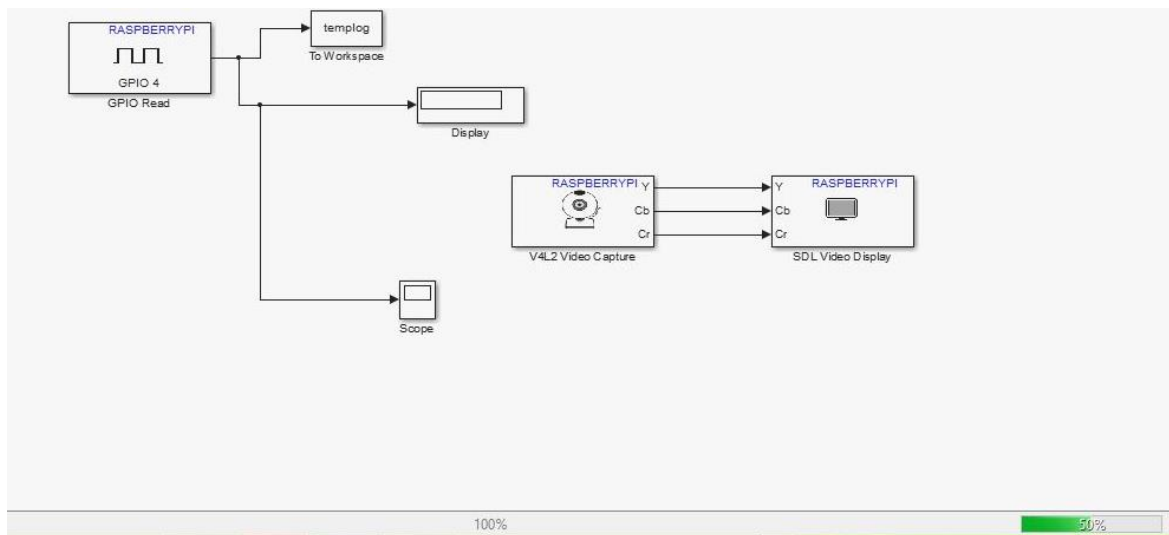

Figure 3 9 Simulink model for temperature sensing with camera module

- The Video capture mode was configured where the webcam being connected to Raspberry Pi sent me the video as well As the temperature information.



Figure 3-10 Hardware set up for temperature sensing and camera module.

### 3.5 TECHNIQUES USED

Photoplethysmography (PPG) is a straightforward and cheap optical technique that may be accustomed to notice blood volume changes within the microvascular bed of tissue. It's typically used non-invasively to create measurements at the skin surface. The PPG waveform comprises a pulsatile ('AC') physiological waveform that corresponds to cardiac synchronous changes in the blood volume with each heartbeat, which is superimposed on a slowly varying ('DC') baseline with various lower frequency components attributed to respiration, sympathetic nervous system activity and thermoregulation. The PPG technology has been utilized in commercially accessible medical devices for measuring pressure level, rate of flow, and conjoint detection of peripheral vascular illness.

### 3.6 PROCEDURE

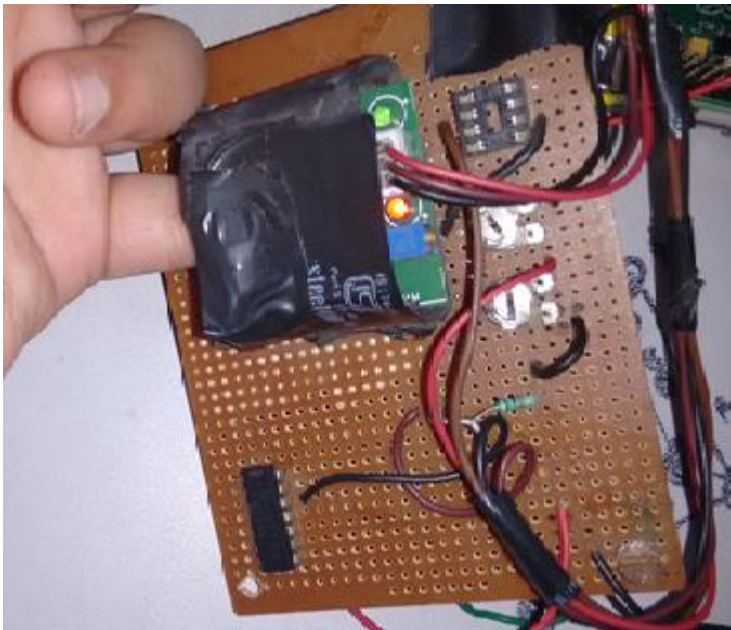

Figure 3- 11 Hardware set up for the pulse rate measurement

The TCRT1000 sensor is a reflective optical sensor which has an infra-red light emitter and phototransistor placed besides each other and are covered in a black material to prevent the external interfering light. The green LED glows and indicates that the sensor is on and the amount of infra-red light reflected back from the fingertip (that acts as a reflector) is analysed by the phototransistor. The output is a waveform synchronous with

the heartbeat and indicated the pulsatile blood volume changes. The finger needs to be still and should not press the sensor too hard. The board operates on 3.3V. The procedure used here is transmittance PPG, which is limited to parts like finger and ear lobe. The potentiometers provide a voltage divider and LM324D is an operational amplifier which performs signal conditioning and amplification of the meagre signal obtained. The frequency of the pulses obtained is related to heart as  $BPM=60*f$ .

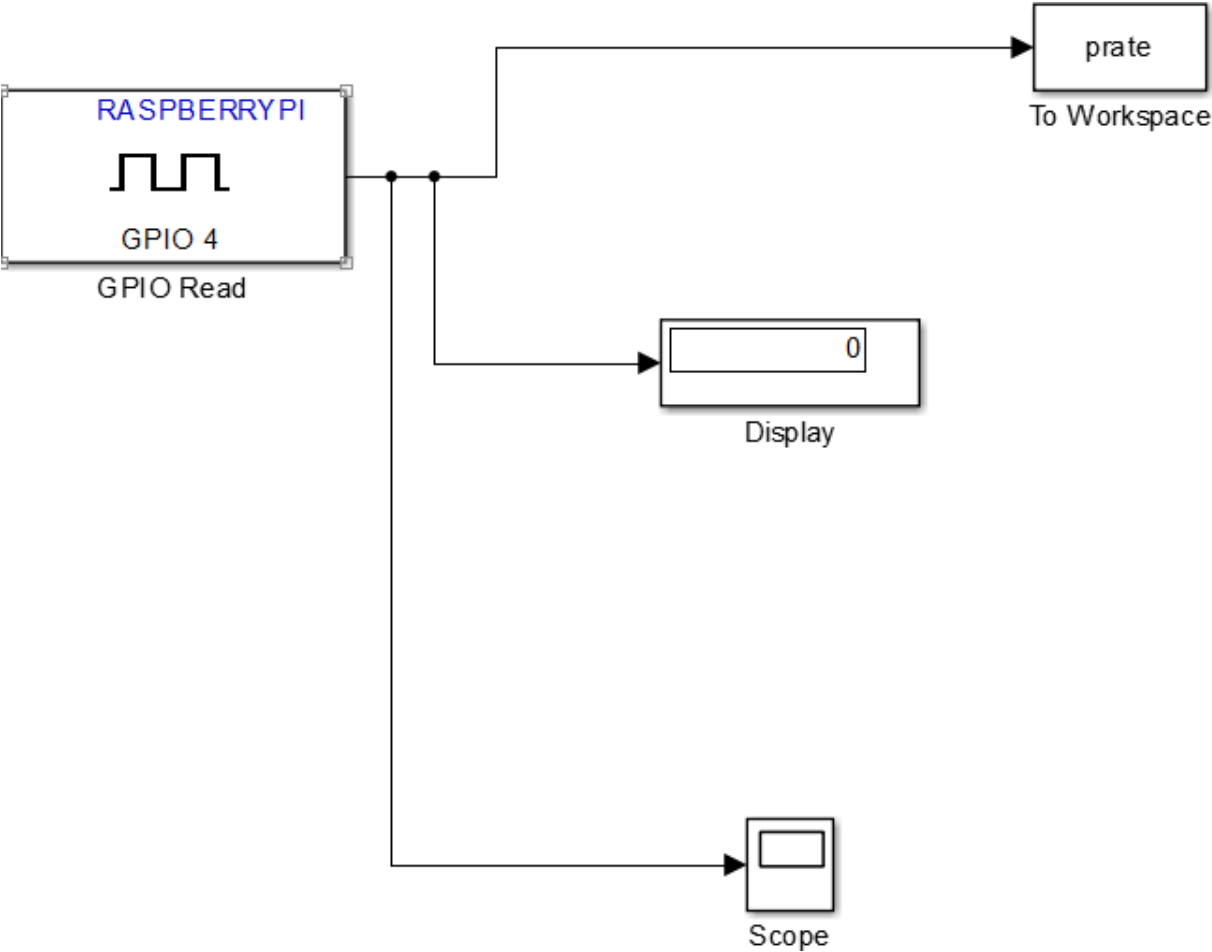

Figure 3-12 Simulink model for the pulse measurement

Age	20	30	40	50	60	70+
Maximum heart rate (bpm)	200	192	183	175	166	158
80% of maximum heart rate (bpm)	160	153	146	140	133	126

Figure 3 -13 Maximum and 80% heart rate according to age

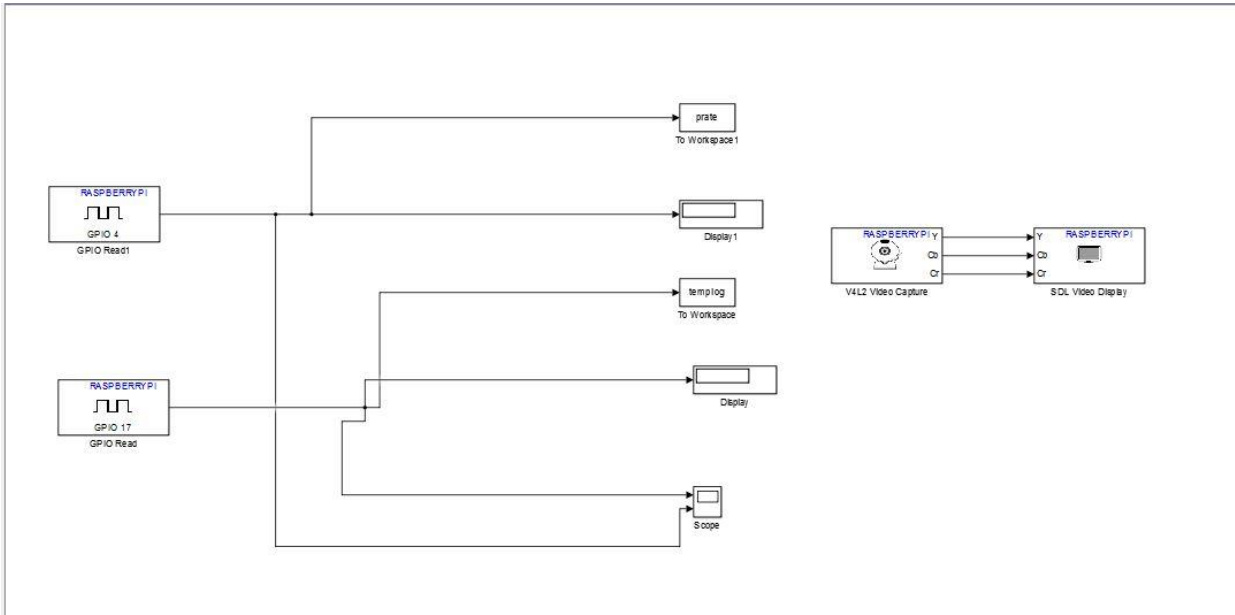

Figure 3-14 Simulink model for temperature sensing, pulse rate and the video conferencing

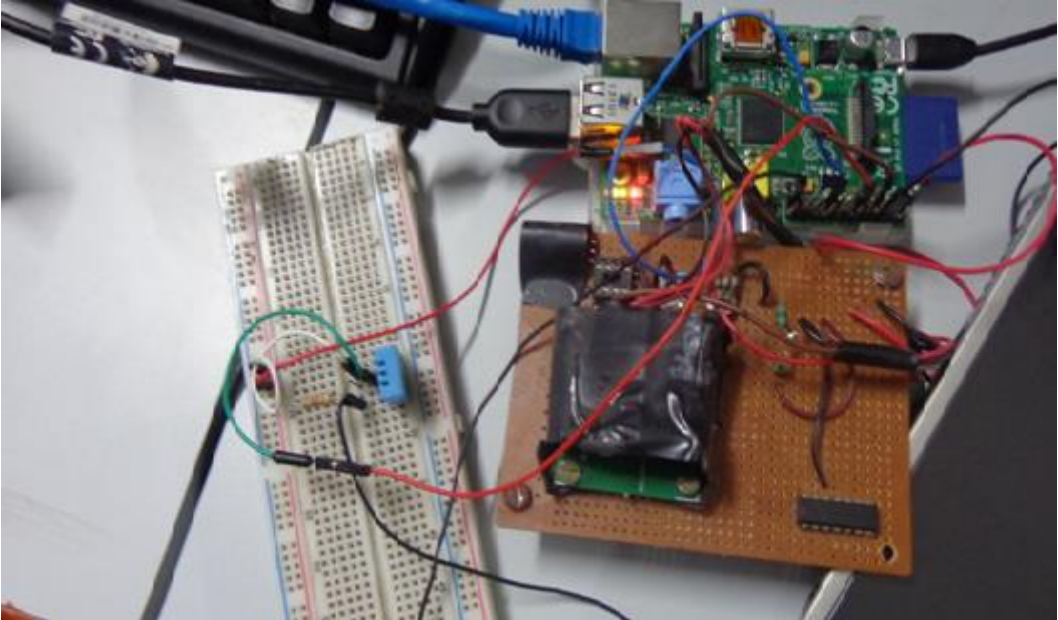

Figure 3-15 Hardware set up for temperature sensing, pulse rate and the video conferencing.

## Chapter 4: Results and Analysis

This chapter includes the results of the circuits and schematics as mentioned in the previous chapter. It also includes the explanation of the various results for a better understanding.



## 4.1 RESULTS AND ANALYSIS



Figure 4-1 GPIO output

This is the output where the LED glows indicating there is output from the GPIO pin of the Raspberry Pi.

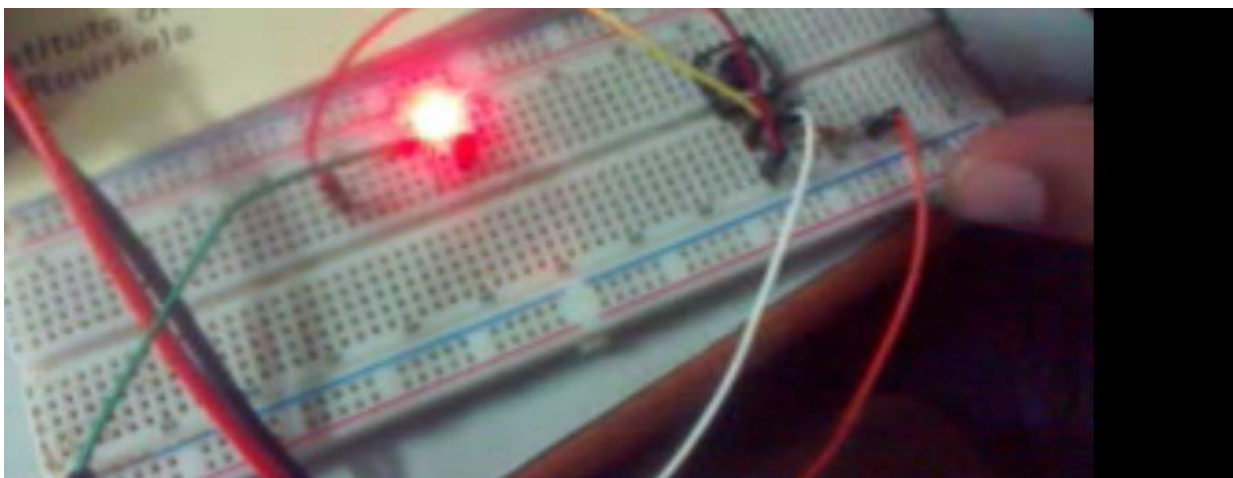

Figure 4-2 GPIO input and output

This is the output in the case where we give input to GPIO pin through a push button and then the output is fed into an LED. So this establishes the ground work for communication between the laptop and Rpi via LAN.

templog		ts	
249x1 double		249x1 logical	
	1		1
1	0.4000	122	1
2	0.6000	123	1
3	0.8000	124	0
4	1	125	0
5	1.2000	126	0
6	1.4000	127	0
7	1.6000	128	0
8	1.8000	129	1
9	2	130	1
10	2.2000	131	1
11	2.4000	132	1
12	2.6000	133	1
13	2.8000	134	1
14	3	135	1
15	3.2000	136	1
16	3.4000	137	1
17	3.6000	138	1

Figure 4- 3 Time and temperature signals

This corresponds to the Time signals and the output from the temperature sensor, variation is represented by a 0-1 transition.

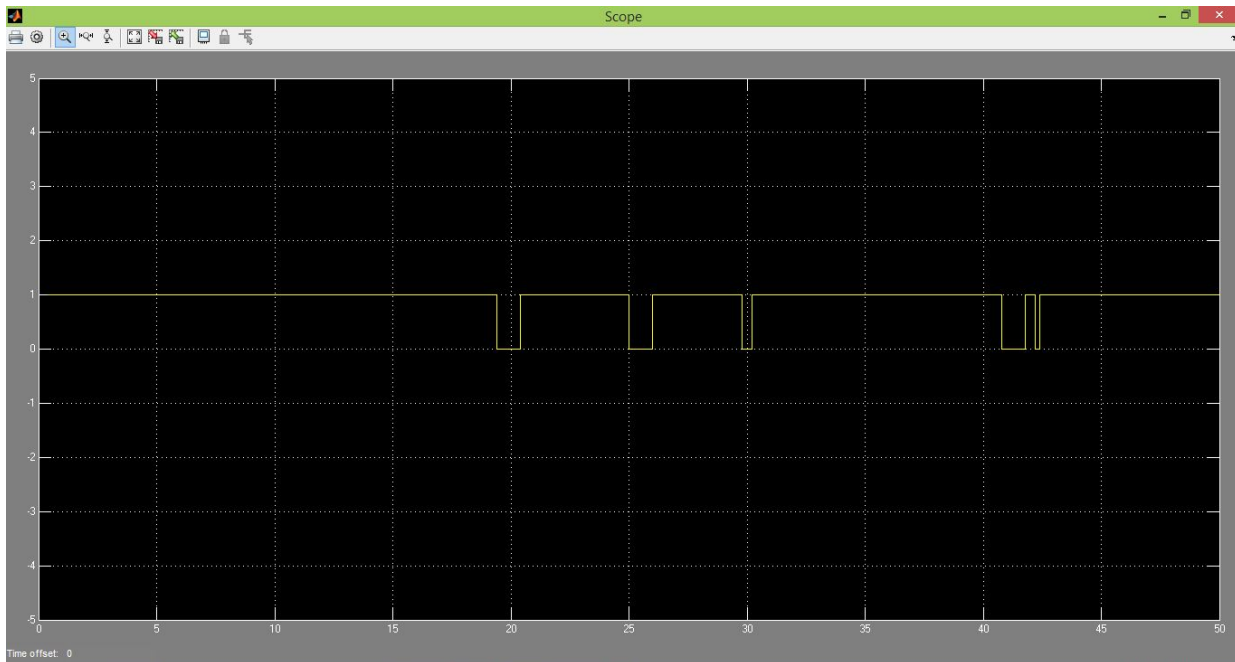

Figure 4 4 Temperature Graph

This graph shows the temperature signals as varying with time. The signals vary between 0 and 1 as shown.

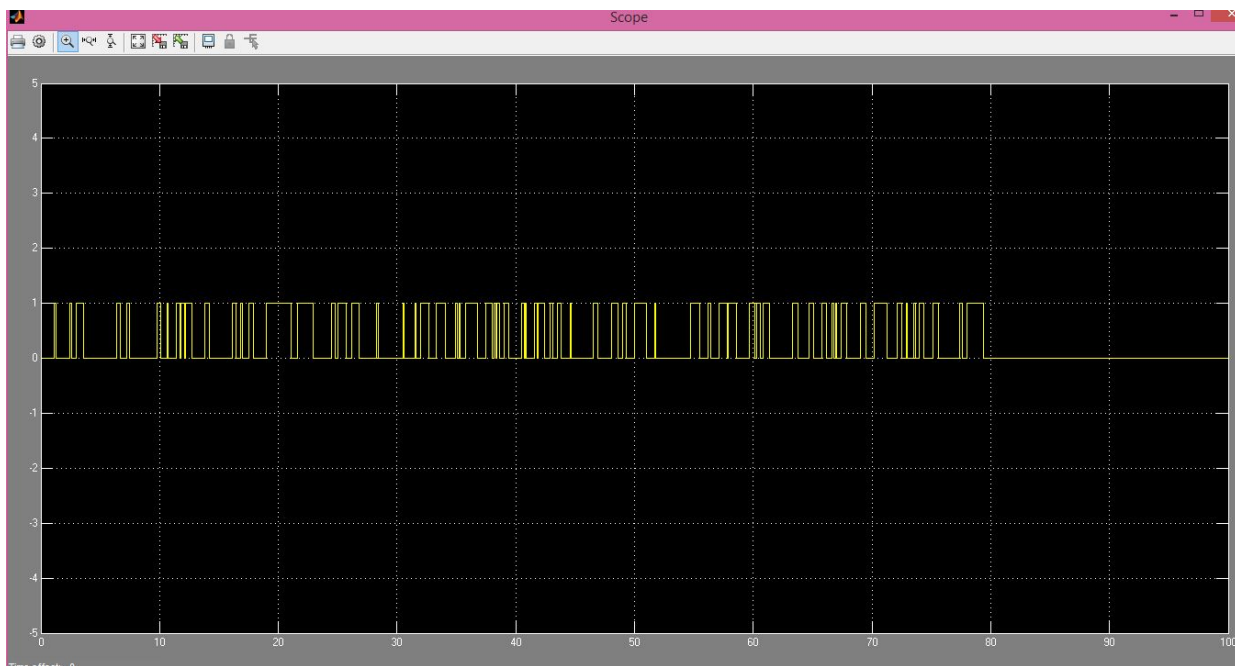

Figure 4 5 Pulse rate graph

Pulse rate graph 1. The 0-1 transition represent the volume change in blood as indicated by the LED.

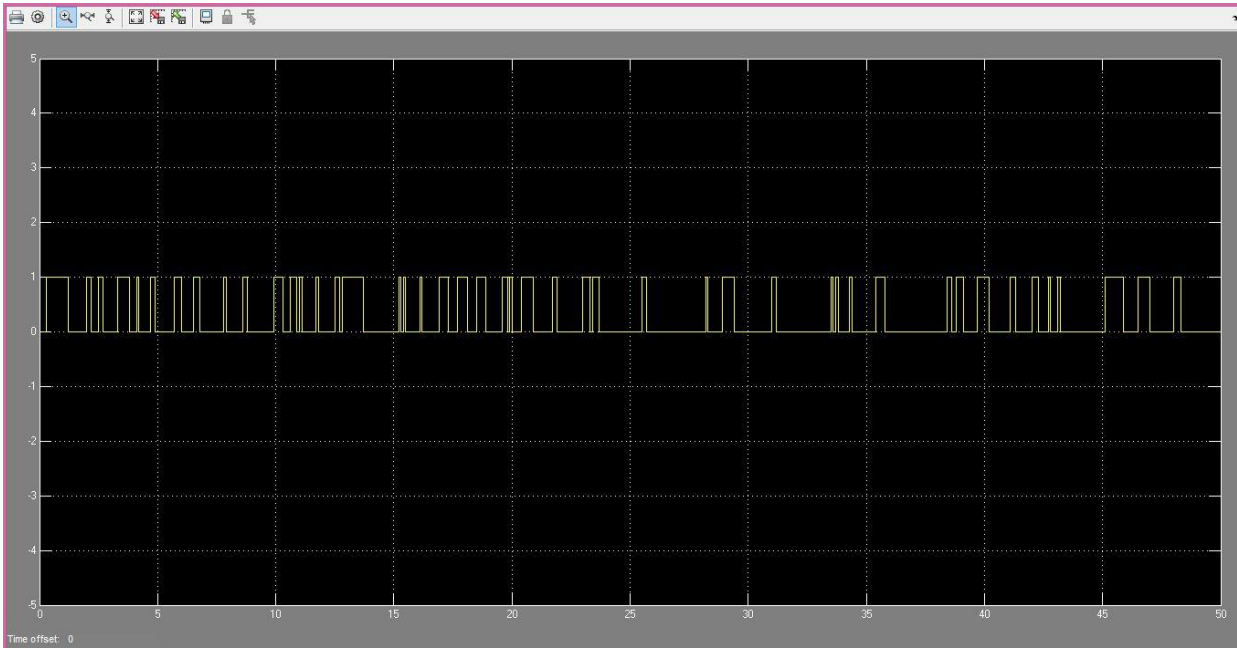

Figure 4 - 6 Pulse rate graph 2

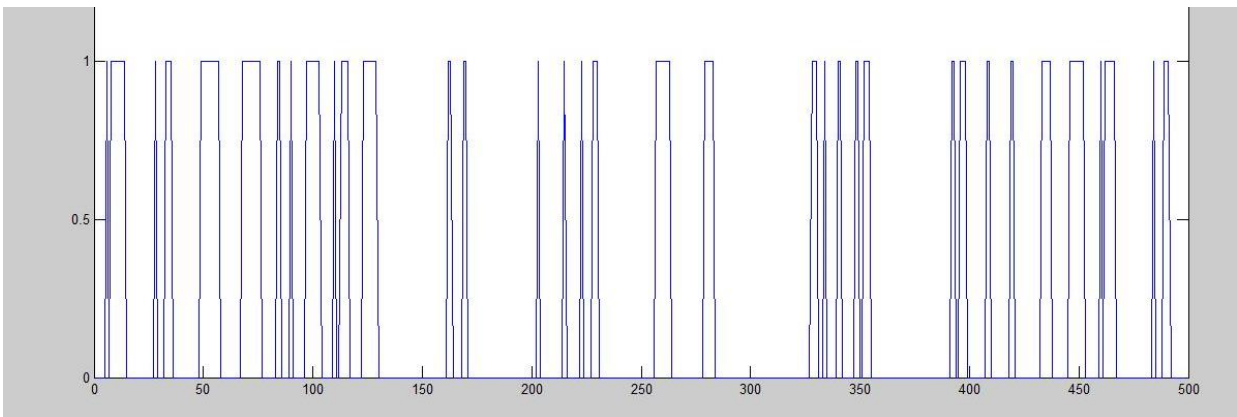

Figure 4-7 Graph plotted between time and signal values

This is the graph plotted in Matlab using plot function, between time signals and values.

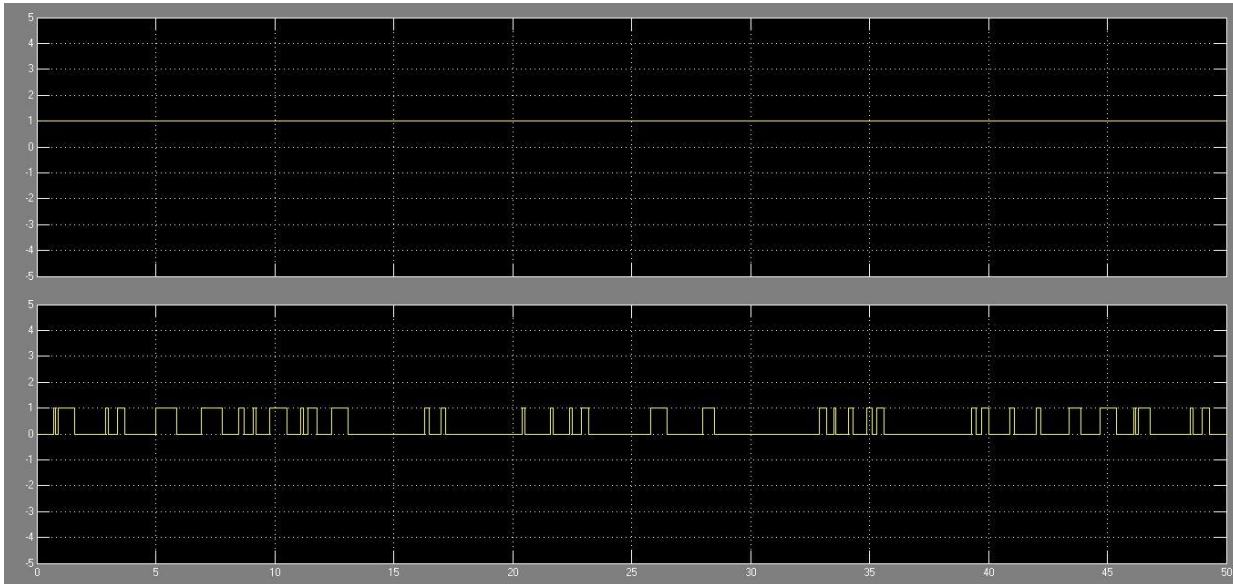

Figure 4 - 8 combined graph of temperature and pulse

This is the result where both the temperature and pulse rate are taken together in one module. The temperature of the person is constant and is represented by a constant straight line.

The number of peaks in the pulse rate graph in 50 sec is 56

So thenumber of peaks in 60 sec is  $56 * 60/50 = 67.2$  bpm

Measured pulse rate of subject is 68bpm and this is the normal pulse rate

Measured temperature was 37 degree celcius which remained constant for around 20 mins and was so verified in the simulation.

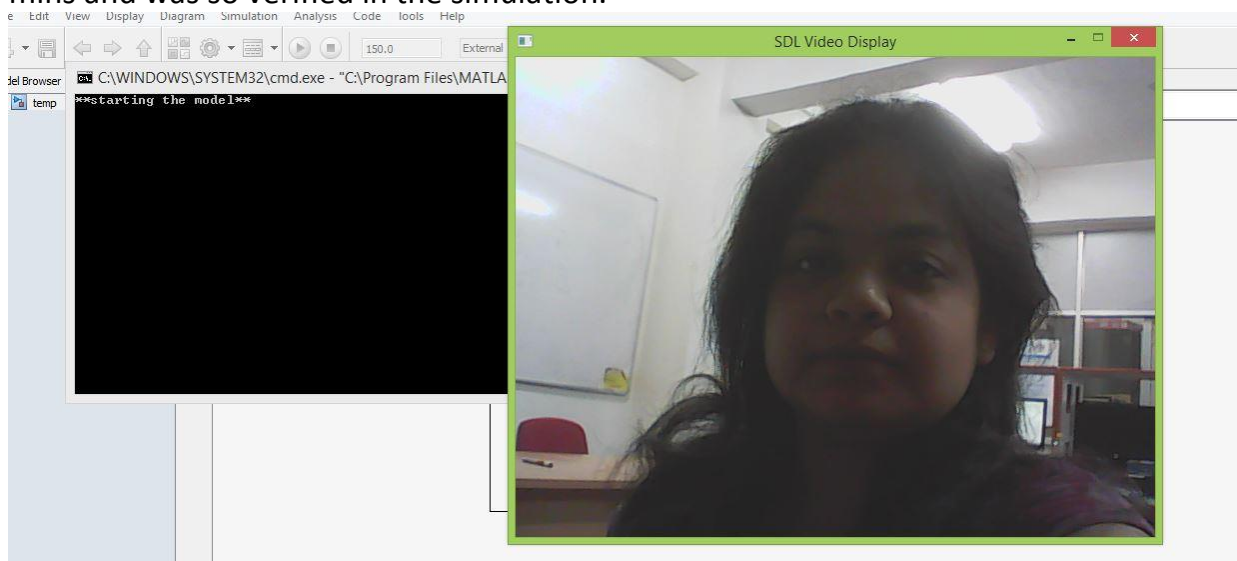

Figure 4 9 Facial Snapshot using camera module

The output of the camera module. The snapshot of my face along with the command prompt window indicating that the simulation is running.

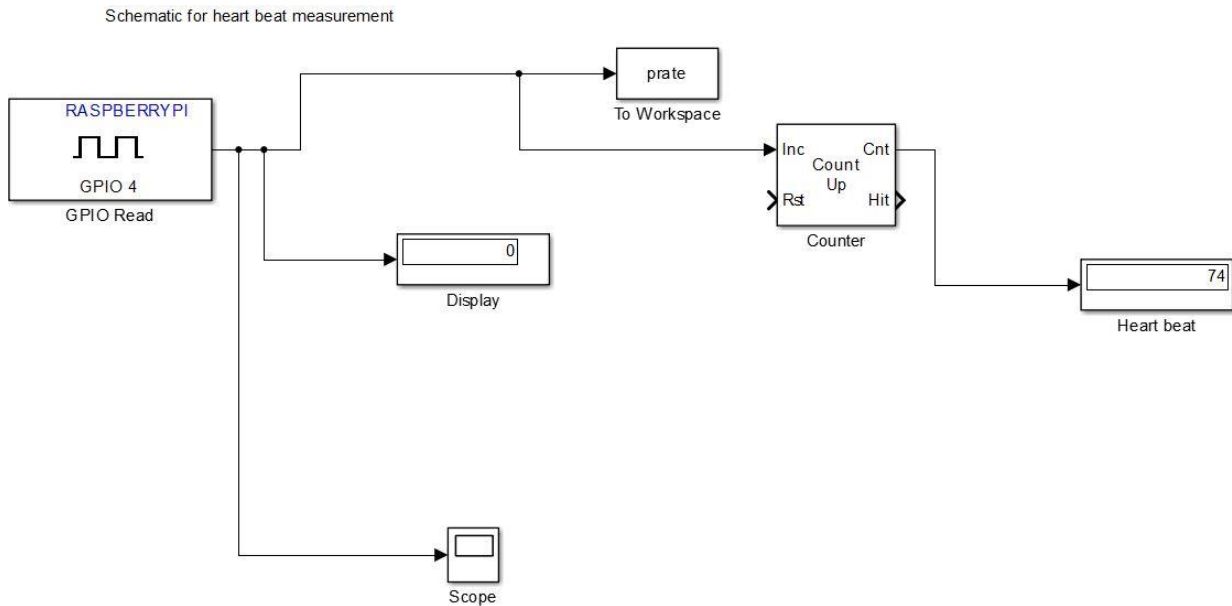

Figure 4 - 10 Model displaying the heart rate in display block

This block diagram shows the heartbeat on a display without any kind of manual manipulation. It is shown to be 74 bpm. [10] For adults 18 and older, a normal resting heart rate is between 60 and 100 beats per minute (bpm), depending on the person's physical condition and age. For children ages 6 to 15, the normal resting heart rate is between 70 and 100 bpm, according to the AHA.

```

**starting the model**
** starting the model **
**stopping the model**
**Simulation finished**
C:\Users\Dikshya Rath\Documents\MATLAB\combinedmodel_rtt>

```

Figure 4 - 11 Simulation finished

## Chapter 5 Conclusion and future work.

This chapter includes the detailed comprehensive analysis and conclusion of the outputs obtained along with the scope of future work.

## 5.1 CONCLUSION

In this chapter the Simulations for temperature measurement, Heartbeat measurement were carried out using the Simulink models in the laptop and Raspberry Pi where both the devices communicated with each other via the Local Area Network of the Electronics Department. The method used for heartbeat measurement i.e Photoplethysmography is as described in chapter 3 along with the software and hardware used. The graphs were plotted following a critical analysis of the results and thus establishing the aim of the project. The constant temperature and the normal heartbeat established the fact that the person has not consumed alcohol and can ride a vehicle safely.

## 5.2 SCOPE FOR FUTURE WORK

The analysis is not very detailed with respect to the aim I wanted to achieve. Few aspects like that of spO2 concentration can also be taken into account to check for the alcohol inhalation. The DHT11 sensor can be replaced by a more accurate one. The Simulink models though easy to use yet increase time complexity hence can be replaced by Python or C codes and the results can be logged in google spreadsheet too. All these changes combined can give better and accurate results thus leading to concrete conclusions. The data can be analysed by healthcare professionals for health hazards or crime investigators for reduction in drunk and drive cases. Here, I have used a heartbeat sensor that needs to be present with the patient as well as the system. So, the mobility of the patient is restricted as a result of this. To avoid this, a more sophisticated heartbeat sensor can be used which can be carried by the patient for which the following changes need to be done like, the heartbeat sensor should incorporate an in-built RF transmission system or else a Bluetooth system that can be used to transmit data to the microcontroller for further processing and analysis. The whole connections can be furnished into a product. Smaller microcontrollers like Beagle bone and Arduino can also be used. Wi-Fi module in Raspberry Pi helps in wireless data transmission, rather than using the Ethernet cable module.



## REFERENCES

- [1] "Wikipedia," [Online]. Available: [http://en.wikipedia.org/wiki/Machine\\_to\\_machine](http://en.wikipedia.org/wiki/Machine_to_machine).
- [2] Dibyajyoti. Behera. Kaustav Mishra, *Application on Machine to Machine communication in health care*, NIT, Rourkela, 2013.
- [3] "White paper on Machine to machine communication," May 2006. [Online]. Available: <http://www.tec.gov.in>.
- [4] Prashant. Kumar, "Wipro," 2011. [Online]. Available: [http://www.wipro.com/documents/resource-center/Machine\\_to\\_machine.pdf](http://www.wipro.com/documents/resource-center/Machine_to_machine.pdf).
- [5] Seema. V. Kamkhedkar. Dr.Prakash.H.Patil, "Wireless Machine to Machine (M2M) based eHealthcare," *International Journal for Research in Applied Science & Engineering*, vol. 2, no. 12, p. 6, 2014.
- [6] Rong. Yu. Shenglie Xie. Yan Zhang, "Home M2M Networks: Architectures, Standards, and QoS Improvement," *IEEE Communications Magazine*, p. 9, 2011.
- [7] "Raspberry Pi," [Online]. Available: <https://www.raspberrypi.org/>.
- [8] "Aosong Electronics," [Online]. Available: <http://akizukidenshi.com/download/ds/aosong/DHT11.pdf>.
- [9] "ON Semiconductors," [Online]. Available: [http://www.onsemi.com/pub\\_link/Collateral/LM324-D.PDF](http://www.onsemi.com/pub_link/Collateral/LM324-D.PDF).
- [10] "<http://www.livescience.com/42081-normal-heart-rate.html>," [Online].
- [11] Sung Chul. Lee and Soo Hyun Park, "International Journal of Distributed Sensor Networks," *A Smart Electronic Tagging System Based on Context, Awareness and Machine-to-Machine Interworking*, vol. 2013, p. 18, 2013.
- [12] Rong. Yu, Shenglie Xie, Yan Zhang, "Cognitive Machine-to-Machine Communications: Visions and Potentials for the Smart Grid," IEEE, 2012.
- [13] D S Pradeep. M. Sreeram Charan. K. Ch Srikanth, "Smart Embedded Medical Diagnosis using Arduino and Beagle bone," *International Journal of Engineering Trends and Technology*, vol. 8, no. 1, p. 6, 2014.
- [14] D.Mahalingam. M Jayalakshmi,A. Rajeshwari, "Advanced Health Monitoring and Receiving Using Smartphone in Global Networks," *International Journal of Engineering Development and Research*, vol. 2, no. 1, p. 5, 2014.
- [15] "Innovation world cup," [Online]. Available: <http://www.innovationworldcup.com/2012/12/healthcare-revolution-enabled-machine-machine-communication-bringing-vital-data-cloud/>.

