

FREE VIBRATION OF STEPPED BEAM WITH MULTIPLE TRANSVERSE CRACKS

A thesis submitted in partial fulfillment of

the requirements for the award of

Master of Technology

In

Structural Engineering

By:

B.Rohini

Roll no: 213CE2057



DEPARTMENT OF CIVIL ENGINEERING

NATIONAL INSTITUTE OF TECHNOLOGY, ROURKELA

MAY 2015

FREE VIBRATION OF STEPPED BEAM WITH MULTIPLE TRANSVERSE CRACKS

A thesis submitted in partial fulfillment of
the requirements for the award of

Master of Technology

In

Structural Engineering

By:

B.Rohini

Roll no: 213CE2057

Under the guidance of

Prof. Shishir Kumar Sahu



**DEPARTMENT OF CIVIL ENGINEERING
NATIONAL INSTITUTE OF TECHNOLOGY, ROURKELA
MAY 2015**



NATIONAL INSTITUTE OF TECHNOLOGY

ROURKELA

CERTIFICATE

*This is to affirm that the thesis entitled, “Free vibration of stepped beam with multiple transverse cracks” submitted by **B.Rohini** in partial fulfilment of the requirements for the award of **Master of Technology Degree in Civil Engineering** with specialization in “**Structural Engineering**” at **National Institute of Technology, Rourkela**, is an authentic work carried out by her under my supervision and guidance.*

To the best of my knowledge, the matter embodied in this thesis has not been submitted to any other university/ institute for award of any Degree or Diploma.

Prof. Shishir Kumar Sahu
Department of Civil Engineering
National Institute of Technology
Rourkela, Odisha

ACKNOWLEDGEMENT

I take it as privilege to express my gratitude towards my guide, **Prof. Shishir Kumar Sahu**, Professor and Head, Department of Civil Engineering, National Institute of Technology, Rourkela, for his continuous help and encouragement. It has been an honor to work under the supervision of Prof.S.K.Sahu, whose valuable guidance and support enriched the quality of work.

I express my sincere regards to Prof. **S.K. Sarangi**, Director of NIT, Rourkela & my faculty advisor, **Prof. M.R.Barik**, Dept. of Civil Engineering NIT, Rourkela for giving me the needful resources in the department.

I express my heartfelt thanks to Ms.Shubhashree Behera, Mrs.Madhusmita and Ms.SharathDhruthi Boga for giving their valuable suggestions and inspiration during the M.Tech program. I would additionally take this opportunity to thank my juniors Vamshi Krishna, Akhila Basu for their kind co-operation during the course of experimental work. Many thanks to my friends K.V.Vydehi, D.Srikanya , K.Krishnasagar, S.Suleiman who helped me during my project work.

This acknowledgement would be incomplete without expressing my sincere thanks to Mr.R.Lugun and Mr.Sushil for their contribution throughout the experimental work.

Finally, I would like to dedicate my work to my family whose constant inspiration and motivation helped me a lot for the successful completion of the project.

(B.Rohini)

ABSTRACT

The present study outlines free vibration analysis of uniform and stepped beam subjected with single to multiple cracks using Finite Element Method (FEM) in MATLAB environment. The crack considered is transverse crack which open in nature. Due to the presence of crack, the total flexibility matrix is established by adding local additional flexibility matrix to the flexibility matrix of the corresponding intact beam element .The local additional flexibility matrix is obtained from Linear Elastic Fracture Mechanics theory. An experimental study is carried out to check the accuracy of the numerical results. Mild steel specimens of square area of cross section are considered for the experiment and the experimental results are compared with numerical analysis using Finite Element Method (FEM) in MATLAB environment. The results obtained from experimental are checked for accuracy with the present analysis by plotting non-dimensional frequencies for first three modes as function of crack depth ratios for different locations of cracks.

TABLE OF CONTENTS

ACKNOWLEDGEMENT	I
ABSTRACT.....	II
LIST OF TABLES	VI
LIST OF FIGURES	VI
NOTATIONS.....	XII
ORGANIZATION OF THESIS	XIII
1. INTRODUCTION.....	1
1.1. Introduction	1
1.2. Research Significance.....	2
1.3. Objective.....	2
2. REVIEW OF LITERATURE.....	3
2.1. Introduction	3
2.2. Vibration of Uniform beam with cracks.....	3
2.3. Vibration of stepped beam with cracks	6
2.4. Critical discussion on literature review	8
2.5. Scope of the present study	8
3. THEORY AND MATHEMATICAL FORMULATION.....	9
3.1. Introduction	9
3.2. History and Importance of vibration study in Engineering	9
3.3. Linear Elastic Fracture Mechanics (LEFM) Theory	10
3.4. Methodology.....	12
4. EXPERIMENTAL PROGRAMME.....	16
4.1. Introduction	16
4.2. Material properties.....	16

4.3.	Preparation of stepped beam.....	16
4.4.	Test setup.....	17
4.5.	Procedure for Free Vibration test	19
5.	RESULTS AND DISCUSSIONS	22
5.1.	Convergence study:	22
5.1.1.	Uniform Cantilever Beam with crack.....	22
5.1.2.	Two-stepped cantilever beam without crack	23
5.2.	Comparison with previous study	24
5.2.1.	Free Vibration Analysis of Cracked Uniform Cantilever Beam	24
5.2.2.	Free Vibration Analysis of Cracked Stepped Beams of Rectangular Cross-Section .	25
5.3.	Free vibration of uniform beam subjected to single crack	26
5.3.1.	Uniform fixed-free beam	26
5.3.2.	Uniform free-free beam	29
5.4.	Free Vibration of uniform beam subjected to double cracks.....	31
5.4.1.	Uniform fixed-free.....	31
5.4.2.	Uniform free-free beam	35
5.5.	Free Vibration of uniform beam subjected to triple cracks	38
5.5.1.	Uniform free-free.....	38
5.5.2.	Uniform fixed-free.....	42
5.6.	Free vibration of Stepped beam subjected to single crack	46
5.6.1.	Cantilever stepped beam.....	46
5.6.2.	Free-free stepped beam.....	48
5.7.	Free vibration of Stepped beam subjected to double crack	51
5.7.1.	Free-free stepped beam.....	51
5.7.2.	Cantilever stepped beam.....	54

5.8.	Free vibration of Stepped beam subjected to triple crack	57
5.8.1.	Cantilever stepped beam.....	57
5.8.2.	Free-free stepped beam.....	60
6.	CONCLUSIONS	64
6.1.	Conclusions of the work.	64
6.2.	Scope for the future work.	66
References	67

LIST OF TABLES

Table 5.1 Comparison of natural frequency drawn between Shiffrin (1999) and present FEM analysis.	24
Table 5.2 Comparison of natural frequency drawn between Zhang et.al (2009) and present FEM analysis	25

LIST OF FIGURES

Figure 3.1 Input-Output relationship of a vibratory system.	10
Figure 3.3 A typical cracked beam element subjected to shearing force and bending moment of rectangular cross-section	12
Figure 3.2 Displacement of crack surface of a local element containing the crack front.....	11
Figure 4.1 Modal Impact Hammer (type 2302-5).....	17
Figure 4.2 Accelerometer (type 4507)	17
Figure 4.3 FFT Analyzer (Bruel Kajer FFT analyzer type .3560).....	18
Figure 4.4 Notebook with PULSE software.	18
Figure 4.5 Uniform and Stepped beam specimens	19
Figure 4.6 Free Vibration test setup, beam suspended by two strings like free-free beam, accelerometer and modal hammer in position.....	20
Figure 4.7 Vibration test setup for a cantilever beam with three cracks of uniform depth of 8mm present at $x_1=125\text{mm}$, $x_2=250\text{mm}$, $x_3= 345\text{mm}$	20
Figure 4.8 Vibration test setup for stepped beam with edge crack of depth 10mm located at $x=352\text{mm}$	21
Figure 4.9 Vibration test setup for a stepped beam suspended through strings to look like free-free beam.	21
Figure 5.1 Convergence of fundamental frequency of uniform cantilever beam with single crack.	22

Figure 5.2 Convergence of fundamental frequency of Two- stepped cantilever beam of rectangular cross-section.	23
Figure 5.3 Cracked cantilever beam (mm)	24
Figure 5.4 Cracked cantilever stepped beam (mm)	25
Figure 5.5 Cracked uniform beam (mm)	26
Figure 5.6 Comparison of FEM and experimental results for non-dimensional first natural frequencies of single cracked cantilever beam with location of crack (x/L) for varying crack depth ratios.	26
Figure 5.7 Comparison of FEM and experimental results for non-dimensional second natural frequencies of single cracked cantilever beam with location of crack (x/L) for varying crack depth ratios.	27
Figure 5.8 Comparison of FEM and experimental results for non-dimensional third natural frequencies of single cracked cantilever beam with location of crack (x/L) for varying crack depth ratios.	28
Figure 5.9 Uniform Beam with Crack (mm)	29
Figure 5.10 Comparison of FEM and experimental results for non-dimensional first natural frequencies of single cracked free-free beam with location of crack (x/L) for varying crack depth ratios.	29
Figure 5.11 Comparison of FEM and experimental results for non-dimensional second natural frequencies of single cracked free-free beam with location of crack (x/L) for varying crack depth ratios	30
Figure 5.12 Comparison of FEM and experimental results for non-dimensional first natural frequencies of single cracked free-free beam with location of crack (x/L) for varying crack depth ratios.	31
Figure 5.13 Sketch of uniform cantilever beam with two cracks considered at different locations for the present study.	32
Figure 5.14 Comparison of FEM and experimental results for non-dimensional first natural frequencies of double cracked fixed-free beam with crack depth ratio (a/d) for different locations of crack.....	32

Figure 5.15 Comparison of FEM and experimental results for non-dimensional second natural frequencies of double cracked fixed-free beam with crack depth ratio (a/d) for different locations of crack.....	34
Figure 5.16 Comparison of FEM and experimental results for non-dimensional third natural frequencies of double cracked fixed-free beam with crack depth ratio (a/d) for different locations of crack.....	35
Figure 5.17 Sketch of uniform free-free beam with two cracks considered at different locations for the present study.	36
Figure 5.18 Comparison of FEM and experimental results for non-dimensional first natural frequencies of double cracked free-free beam with crack depth ratio (a/d) for different locations of crack.....	36
Figure 5.19 Comparison of FEM and experimental results for non-dimensional second natural frequencies of double cracked free-free beam with crack depth ratio (a/d) for different locations of crack.....	37
Figure 5.20 Comparison of FEM and experimental results for non-dimensional third natural frequencies of double cracked free-free beam with crack depth ratio (a/d) for different locations of crack.....	38
Figure 5.21 Sketch of uniform cantilever beam with three cracks considered at different locations for the present study.	39
Figure 5.22 Comparison of FEM and experimental results for non-dimensional first natural frequencies of triple cracked free-free beam with crack depth ratio (a/d) for different locations of crack.....	39
Figure 5.23 Comparison of FEM and experimental results for non-dimensional second natural frequencies of triple cracked free-free beam with crack depth ratio (a/d) for different locations of crack.....	40
Figure 5.24 Comparison of FEM and experimental results for non-dimensional third natural frequencies of triple cracked free-free beam with crack depth ratio (a/d) for different locations of crack.....	41
Figure 5.25 Sketch of uniform cantilever beam with three cracks considered at different locations for the present study.	42

Figure 5.26 Comparison of FEM and experimental results for non-dimensional first natural frequencies of triple cracked fixed-free beam with crack depth ratio (a/d) for different locations of crack.....	43
Figure 5.27 Comparison of FEM and experimental results for non-dimensional second natural frequencies of triple cracked free-free beam with crack depth ratio (a/d) for different locations of crack.....	44
Figure 5.28 Comparison of FEM and experimental results for non-dimensional third natural frequencies of triple cracked free-free beam with crack depth ratio (a/d) for different locations of crack.....	45
Figure 5.29 Cantilever Stepped beam (in mm).....	46
Figure 5.30 Comparison of FEM and experimental results for non-dimensional first natural frequencies of single cracked cantilever stepped beam with location of crack (x/L) for varying crack depth ratios.....	46
Figure 5.31 Comparison of FEM and experimental results for non-dimensional second natural frequencies of single cracked cantilever stepped beam with location of crack (x/L) for varying crack depth ratios.....	47
Figure 5.32 Comparison of FEM and experimental results for non-dimensional third natural frequencies of single cracked cantilever stepped beam with location of crack (x/L) for varying crack depth ratios.....	48
Figure 5.33 Free-Free stepped beam with crack (in mm).....	49
Figure 5.34 Comparison of FEM and experimental results for non-dimensional first natural frequencies of single cracked free-free stepped beam with location of crack (x/L) for varying crack depth ratios.....	49
Figure 5.35 Comparison of FEM and experimental results for non-dimensional second natural frequencies of single cracked free-free stepped beam with location of crack (x/L) for varying crack depth ratios.....	50
Figure 5.36 Comparison of FEM and experimental results for non-dimensional third natural frequencies of single cracked free-free stepped beam with location of crack (x/L) for varying crack depth ratios.....	51
Figure 5.37 Sketch of stepped free-free beam with two cracks considered at different locations for the present study.	52

Figure 5.38 Comparison of FEM and experimental results for non-dimensional first natural frequencies of double cracked free-free stepped beam with varying crack depth ratios for different locations of crack.	52
Figure 5.39 Comparison of FEM and experimental results for non-dimensional second natural frequencies of double cracked free-free stepped beam with varying crack depth ratios for different locations of crack.	53
Figure 5.40 Comparison of FEM and experimental results for non-dimensional third natural frequencies of double cracked free-free stepped beam with varying crack depth ratios for different locations of crack.	54
Figure 5.41 Sketch of stepped fixed-free beam with two cracks considered at different locations for the present study.	55
Figure 5.42 Comparison of FEM and experimental results for non-dimensional first natural frequencies of double cracked free-free stepped beam with varying crack depth ratios for different locations of crack.	55
Figure 5.43 Comparison of FEM and experimental results for non-dimensional second natural frequencies of double cracked free-free stepped beam with varying crack depth ratios for different locations of crack.	56
Figure 5.44 Comparison of FEM and experimental results for non-dimensional third natural frequencies of double cracked free-free stepped beam with varying crack depth ratios for different locations of crack.	57
Figure 5.45 Different cases of locations of triple cracks considered for Cantilever Stepped beam (in mm)	57
Figure 5.46 Comparison of FEM and experimental results for non-dimensional first natural frequencies of triple cracked fixed-free stepped beam with varying crack depth ratios for different locations of crack.	58
Figure 5.47 Comparison of FEM and experimental results for non-dimensional second natural frequencies of triple cracked fixed-free stepped beam with varying crack depth ratios for different locations of crack.	59
Figure 5.48 Comparison of FEM and experimental results for non-dimensional third natural frequencies of triple cracked fixed-free stepped beam with varying crack depth ratios for different locations of crack.	60

Figure 5.49 Different locations of triple cracks considered for Free-Free Stepped beam (in mm)
..... 61

Figure 5.50 Comparison of FEM and experimental results for non-dimensional first natural frequencies of triple cracked free-free stepped beam with varying crack depth ratios for different locations of crack. 61

Figure 5.51 Comparison of FEM and experimental results for non-dimensional second natural frequencies of triple cracked free-free stepped beam with varying crack depth ratios for different locations of crack. 62

Figure 5.52 Comparison of FEM and experimental results for non-dimensional third natural frequencies of triple cracked free-free stepped beam with varying crack depth ratios for different locations of crack. 63

NOTATIONS

G = the strain energy release rate and

A_c = the effective cracked area

E = Modulus of Elasticity

ν = Poisson's ratio

ρ = Density

L_c = Distance between the right hand side end node and the crack location

L_e = Length of the beam element.

A = Cross-sectional area of the beam

x = Location of the crack from the fixed of the beam

d = Depth of the rectangular beam

b = Width of the beam

a/d = Crack-depth ratio

ORGANIZATION OF THESIS

The thesis is organized into 7 chapters. A brief introduction of the applications of uniform and stepped beam and degradation due to presence of crack along with the objective of the present study is presented in **Chapter 1**.

Chapter 2 provides a detailed review of literature significant to the previous research works made in this field has been listed. Based on literature survey, critical discussion is presented. The scope of the present study is also outlined.

Chapter 3 covers the theory and mathematical formulation of uniform and stepped beam with transverse open cracks .The theory of crack and vibration is also outlined this chapter. And the importance and history of vibration study in the engineering field is also highlighted in this chapter.

Chapter 4 is devoted to the understanding of the experimental programme for the free vibration analysis of uniform and multiple stepped beams with transverse cracks. It includes the test setup and procedure for the vibration test.

Chapter 5 deals with the results and discussions pertaining to the comparison drawn between the present (FEM) analysis and experimental study. A detailed investigation of the presence of multiple cracks on uniform and stepped beam has been outlined illustratively.

Chapter 6 presents the conclusions inferred from the detailed description of the results obtained. A brief note regarding the future scope for the study is also mentioned in this chapter.

Chapter 7 presents the books, journal publications which were referred during the present study.

Chapter 1

1. INTRODUCTION

1.1. Introduction

For many engineering applications, beams are essential models for the structural elements and have been studied extensively. Optimization requirements led to reduction in the weight of structure resulting to enhanced operating stress levels. Some of the applications of beam-like elements are helicopter rotor blades, robot arms, aircraft wings, spacecraft antennae, and long span bridges. Structural elements and systems are very frequently subject to loads changing with time. Ignoring the presence of material defects while designing led to spectacular failures. Due to this the fatigue changes in the element conceive cracks that hinders the potential of the element to withstand its capacity. The sudden failure of structures is result of the crack damage propagation if it is not detected well before. So, it becomes essential regarding safety question of the structure performance to monitor such defects. Successful design of engineering structures for long term life requires the understanding of different modes of failures and degradation mechanisms (crack growth due to service loads, corrosion, hydrogen embrittlement, etc); so that sufficient margins against these mechanisms can be built-in during the design phase itself.

The natural frequencies point out the dynamic stiffness of any structure. The frequency being higher indicates that the structure is stiffer dynamically. It depends on the values of mass, stiffness distributions and the end conditions. The vibration response is affected due to the local flexibility which is initiated due to presence of crack in structural member. It leads to decrease in

frequencies when compared to the frequencies that occurred naturally and changes in mode patterns of vibrations. Any detection of these differences makes likely to detect cracks.

1.2. Research Significance

To assist in a constant safety evaluation of a structure it is very necessary to regularly review the health of its critical components. This makes it necessary for a continuous evaluation of changes in their dynamic behavior. The cracks initiate the change in the structure by local reduction of structural stiffness. The presence of crack is a warning that the behavior of structure should be checked carefully, it does not make the component completely out of use. Such scrutinizing can play a major role in giving surely an uninterrupted operation in service by the component. This has made the monitoring of components consisting of cracks or crack-like defects in service very vital on the basis of vibration and the vibration of components with crack are widely studied.

1.3. Objective

The main objective is to study and compare the numerical and experimental results of free vibration study of uniform and multiple stepped beams without and with cracks.

Chapter 2

2. REVIEW OF LITERATURE

2.1. Introduction

Many studies concerning two aspects mainly either to determine natural frequencies from crack details or to determine crack details from the measurement of vibration parameters, in beams has drawn attentions of researchers from many years. Researchers have mostly focused on the analytical modeling to describe in better way how the crack affects the natural frequency due to local flexibility induced by the crack. Some of the papers in which the different loading conditions like axial, shear, etc are considered are also discussed here.

2.2. Vibration of Uniform beam with cracks

Shen and Pierre (1986) presented a finite element approach to predict the changes in the first few Eigen frequencies, Eigen modes due to presence of crack. Eight nodes Isoperimetric element is used to model across the thickness of the beam. **Rizos et.al (1989)** determined vibrations of a cantilever beam having transverse crack and analytical results are used to speak about the measured vibration modes to the depth and location of crack. Amplitudes are measured at two spots of the structure when it is vibrating at one of its natural modes, the frequency, analytical solution of the dynamic response along with the crack location are determined and the depth of crack is approximated. **Qian etal (1990)** developed a finite element model which is then validated to a cantilever beam with an edge crack. Eigen frequencies are determined for different crack locations and depths which are then verified experimentally. **Pander teal (1991)** employed a cantilever and hinged-hinged beam models to show that in the region of damage absolute

changes in the mode shapes are localized which is utilized to detect damage in structure. **Shen and Pierre (1994)** have derived the equation of motion and related end conditions for a uniform Bernoulli-Euler beam having one edge crack. The generalized principle used permits for displacement fields, modified strain and stress that satisfy the compatibility requirements in the vicinity of the crack. **Rutolo and Surace (1997)** used a finite element model of structure to analyze the dynamic behavior analytically to formulate the inverse problem. Cantilever steel beams each with a different damage scenario, the depth and position of the cracks has been demonstrated.

Salawu (1997) discussed the relationships between the frequency changes and structural damage. **Shifrin and Rutolo (1999)** proposed a new technique for enumerating natural frequencies of a beam with a random number of transverse open cracks. Cracks are characterized as massless rotational springs. Compared to the substitute methods which make use of continuous model of beam, the computation time required here was reduced due to the decreased dimension of the matrix. **Kisa et al (2000)** modeled cracked structures by integrating the the finite element method, the linear elastic fracture mechanics theory and the component mode synthesis method. The experimental investigations of the effects of cracks on the first three modes of vibrating beams for both hinged-hinged and fixed –fixed boundary conditions is elaborated by **Owolabi (2003)**. The Frequency Response Function (FRF) amplitudes and changes in natural frequencies obtained from the measurements of dynamic responses of cracked beams as a function of crack depth and location of crack are used for the detection of crack. **Zheng et al. (2004)** obtained the natural frequencies and modeshapes of cracked beam using Finite Element Method (FEM). The total flexibility matrix is established by adding overall additional flexibility matrix to the flexibility matrix of the corresponding intact beam element

.The results when compared with analytical results show more accuracy than when the local additional flexibility matrix was used in the place of overall additional stiffness matrix. **Khiem et al (2004)** obtained numerical results for a cantilever beam with single, two and three cracks .Main focus is laid on the detection of multi-crack for structures by natural frequencies. Accuracy in detecting the crack depth is more if more natural frequencies are measured.

Chen et al (2005) performed experimental investigation for spotting the location and size of crack. The intersection of curves of stiffness versus location of crack for the first three natural frequencies obtained from the vibration of the cantilever beam with crack predicts the crack location and crack depth .**Nahvi et.al (2005)** developed a method for finding the location of crack and crack depth of cantilever beam using linear fracture mechanics theory. To determine the natural frequencies and mode shapes of the beam, a finite element model is constructed. Theoretical and Experimental analysis indicates that the crack depth and location has noticeable effect on first and second natural frequencies of the cantilever beam. **Patil et.al (2005)** verified a method to envisage the location and depth of crack experimentally for cantilever beams with two and three edge cracks. The energy approach method is used for analysis and the crack is represented as a rotational spring. For a particular mode, varying crack location, a plot of stiffness versus crack location is obtained. The intersection of these curves consequent to the three modes gives the crack location and the associated rotational spring stiffness. **Yoon et.al (2007)** investigated analytically and experimentally the affect of presence of two open cracks on the dynamic response of a double cracked hinged-hinged ended beam. The simply supported beam is modeled by the Euler-Bernoulli beam theory. **Karagaac et.al (2009)** studied the effects of crack depth ratios and locations on the first natural frequencies and buckling loads of slender cantilever Euler beams with edge crack both experimentally and numerically using the finite

element method. Aluminium beams chosen for the experimental study have edge cracks of varying depths and at different positions to prove the accuracy of the numerical results obtained. **Lee (2009)** presented a simple method to recognize multiple cracks in a beam using the finite element method. The method for identifying double and triple cracks is illustrated by numerical examples.

2.3. Vibration of stepped beam with cracks

Satho (1980) presented a procedure to examine the free vibrations of stepped thickness beam using transfer matrix. The numerical calculations for one stepped, symmetrical beams with rectangular cross sections for two boundary conditions (Clamped and simply supported) are obtained. To check the accuracy of the results obtained are contrasted with the results obtained from the Galerkin's method. **Subramanian and Subramanian (1987)** studied the dynamic behavior of stepped beams with different boundary conditions and step ratios. They stated that the steps can be judiciously included for dynamic tuning. **Saavedra and Cuitino (2001)** presented an experimental and theoretical dynamic response for different multi-beams systems having a transverse crack. The additional flexibility is estimated using the strain energy density function which is given by linear fracture mechanics theory. **Koplow et.al (2006)** have presented an analytical solution for the dynamic response of a discontinuous beam with one step change and an aligned neutral axis. Free-free end condition was considered to obtain direct frequency response functions due to harmonic force or couple excitation at either end location. **Jaworski and Dowell (2008)** using Rayleigh Ritz formulation, Component modal analysis and Finite Element Method(FEM) results obtained from ANSYS to predict the three lowest natural frequencies of multiple-stepped beam. The confirmation of the results is done with the experimental results from impact testing data.

Zhang et.al (2009) illustrated the crack identification method combining wavelet analysis with transform matrix used for crack identification in a complex structure. The peaks of wavelet coefficients give the crack location. Based on the crack location and first two natural frequencies was used to determine the crack depth. The frequency data and mode is obtained from the modal analysis in ANSYS code .**Mao (2011)** employed Adomian Decomposition Method (ADM) to look into the free vibrations of the Euler–Bernoulli beams with multiple steps. The natural frequencies and corresponding mode shapes are obtained for different boundary conditions, step ratios and step locations. **Ameneh et.al (2012)** deliberated a simplistic way for finding, localizing and quantifying number of fractures formed in Euler-Bernoulli multi-stepped beams, by measurement of frequencies occurred naturally and evaluating the unfractured mode patterns. Apart from the procedure being simple, that it has the advantage to detect the unknown number of cracks. **Attar (2012)** illustrated an analytical approach to find the mode shapes and natural frequencies of stepped beam with number of transverse cracks and different end conditions. The stepped beam with cracks is modeled based on the Euler Bernoulli beam theory as an assemblage of uniform sub segments which are connected by massless rotational springs. **Guohui et.al (2013)** studied the free vibration of beams with multiple step changes by discrete singular convolution (DSC). It is observed that the DSC results are even more accurate than the data obtained by the differential quadrature element method for much higher mode frequencies. **Wang (2013)** proposed Differential Quadrature Element Method (DQEM) which is simple and efficient, and can be used to analyze beams with any step changes in cross-section conveniently. Highly accurate natural frequencies of multiple-stepped beams are obtained with an aligned neutral axis.

2.4. Critical discussion on literature review

The present review indicates that most of the studies are concerned either with the finding of natural frequency from details of crack or determination of details of crack from the measurement of vibration parameters, in beams. The studies regarding the multiple cracks are very limited. More attention is gained for vibration analysis of beam with single cracks. Minimal research related to the case of beam with double cracks is done. Experimental research have been carried out by a few researchers, that too, involving at most two cracks. So, the present study is mainly focused in proper understanding of dynamic behavior of stepped beam with multiple cracks.

2.5. Scope of the present study

Regarding to the review of literature, the present work is mainly focused at filling some of the lacunae in proper understanding of the vibration analysis of stepped beam experimentally and numerically in the presence of multiple cracks. Therefore, the present study is designed in the following manner:

- To study and compare the numerical and experimental results of free vibration of uniform and stepped beams of square cross section.
- To study the effect of crack-depth ratio, location of crack in the beam, number of cracks in uniform and stepped beams.

Chapter 3

3. THEORY AND MATHEMATICAL FORMULATION

3.1. Introduction

In this chapter, the theory related to vibration and the Linear Elastic Fracture Mechanics (LEFM) are presented. Then the attention is given to the mathematical formulation of a cracked uniform cantilever beam. The presence of crack reduces the local stiffness matrix which alters the dynamic response of the system.

3.2. History and Importance of vibration study in Engineering

Daniel Bernoulli derived the equation of motion for the transverse vibration of thin beams in 1735, and Euler gave the first solutions of the equation for different end conditions in 1744, which is known to be Euler-Bernoulli or Thin beam theory . Rayleigh included the effect of inertia and presented a beam theory. The improved theory by including the effect of rotary inertia and shear deformation known as Timoshenko or thick beam theory was presented by Stephen Timoshenko in 1921.

The structures planned to support high speed engines and turbines are subjected to vibration. Due to faulty design and poor manufacture, disturbance occurs in engines which results in excessive and disagreeable stresses in the rotating system because of vibration. The vibration causes rapid wear of machine parts. Many buildings, structures and bridges fall because of vibration. The main aim of the vibration analysis to be applied in an industrial or maintenance environment is to reduce the equipment downtime by detecting the flaws and to reduce the maintenance cost. The

natural frequency of vibration is one of the characteristic feature of the vibration of a body when it is under free vibration. It is important to see that the structure is excited by frequencies far away from the natural frequency to limit the amplitude of vibration. If the excitation frequency is very near the natural frequency, the amplitude of the vibration will be excessively large which readily leads to failure due to resonance.

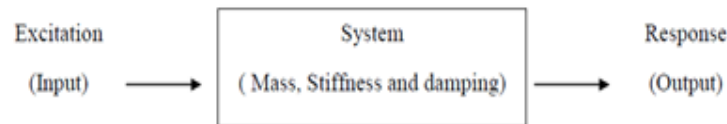

Figure 3.1 Input-Output relationship of a vibratory system.

3.3. Linear Elastic Fracture Mechanics (LEFM) Theory

Kirsch (1898) studied the effect of circular hole in a plate by modeling the hole by polar coordinates. Inglis (1913) studied the effect of elliptical holes, only the affect due to the presence of crack was highlighted. Griffith (1920) presented crack growth ideas through the study of crack in glass. He formulated that the existing crack grows provided the total energy of the system is lowered by growth. But he was not able to express the parameter for it.

Extension of Griffith's ideas for brittle solids to ductile high strength materials was done by Irwin in 1948. The main focus of Irwin's theory laid on crack tip rather than the crack, by moving the analysis to the crack-tip, Irwin devised workable parameters like Stress Intensity Factor (SIF) and energy release rate. LEFM accounts for Small Scale Yielding (SSY). It is quite useful for analyzing aerospace structures.

Irwin observed that there are three independent ways in which two crack faces can move with respect to each other. The corresponding modes are labeled as Mode I, Mode II, Mode III.

The three modes describe all the possible modes of crack behavior in the most general elastic state. A cracked body can be loaded in anyone of the three modes, or as a combo of 2 or 3 modes.

Mode I or Opening mode

Displacements of crack surfaces are perpendicular to the plane of crack. One of the most common and dangerous modes loading for crack growth.

Mode II or Sliding mode

Displacement of crack surface is in the plane of the crack and perpendicular to the leading edge of crack. In many instances, the presence of Mode II is to alter crack growth displacement. Generally referred to as in-plane shear mode.

Mode III or Tearing mode

Displacement of crack surfaces in the plane of crack and parallel to the leading edge of crack. Generally referred to as out of plane shear mode.

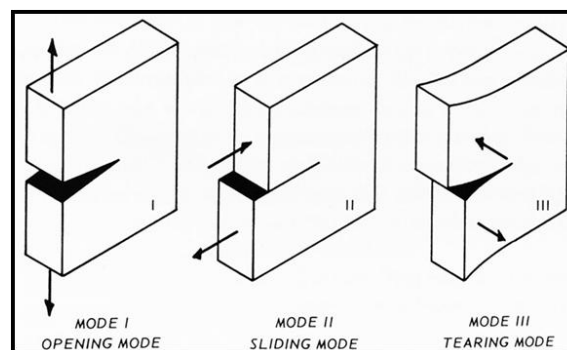

Figure 3.2 Displacement of crack surface of a local element containing the crack front

The relationship used for estimating stress intensity factor is $K = C\sigma\sqrt{a}$

Where K is the critical fracture toughness value, c is a constant that depends on crack and specimen dimensions, σ the applied stress, and size of flaw is represented by a .

3.4. Methodology

A cracked uniform cantilever beam element of rectangular area of cross section with depth ‘ h ’ and breadth ‘ b ’ with crack depth ‘ a ’ is as shown in Figure 1. The left side end which is fixed is denoted with node ‘ i ’ and right side node is denoted with ‘ j ’. The cracked beam element is subjected to shearing force ‘ P_1 ’ and bending moment ‘ P_2 ’. The governing equations of the vibration analysis of the uniform beam with open transverse crack are figured on the basis of the FEM model proposed by **Zheng (2004)**.

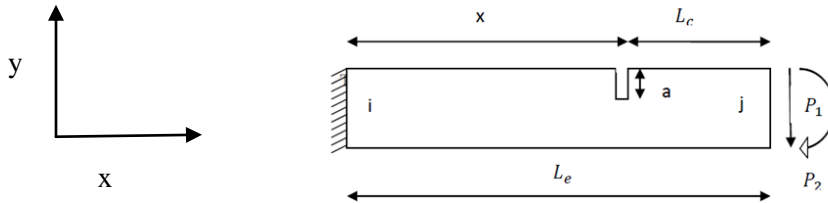

Figure 3.3 A typical cracked beam element subjected to shearing force and bending moment of rectangular cross-section

According to **Zheng (2004)**, the additional strain energy due to the presence of crack is

$$\pi = \int_A G dA_c$$

G = the strain energy release rate and

A_c = the effective cracked area

Where, G = strain energy release rate

$$G = \frac{1}{E'} [(\sum_{n=1}^2 K_{In})^2 + (\sum_{n=1}^2 K_{IIIn})^2 + (\sum_{n=1}^2 K_{IIIIn})^2]$$

K_I, K_{II}, K_{III} are stress intensity factors for opening, sliding and tearing type cracks.

According to the principle of Saint-Venant, the stress field is affected only in the region adjacent to the crack. The element stiffness matrix, except for the cracked element, may be regarded as unchanged under a certain limitation of element size.

Considering the effect of shearing force and bending moment the (neglecting action of axial force) above equation becomes,

$$G = \frac{1}{E'} [(K_{I1} + K_{I2})^2 + (K_{II1})^2]$$

$$K_{I1} = \frac{6P_1 L_c^2}{bh^2} \sqrt{\pi\xi} F_I \left(\frac{\xi}{h}\right)$$

$$K_{I2} = \frac{6P_2}{bh^2} \sqrt{\pi\xi} F_{II} \left(\frac{\xi}{h}\right)$$

$$K_{II2} = \frac{P_2}{bh^2} \sqrt{\pi\xi} F_{II} \left(\frac{\xi}{h}\right)$$

Where, F_I and F_{II} are correction factors for stress intensity factors.

$$F_I(s) = \sqrt{\frac{\tan \frac{\pi s}{2}}{\frac{\pi s}{2}} \left[\frac{0.923 + 0.199 \left((1 - \sin \frac{\pi s}{2})^4 \right)}{\cos \frac{\pi s}{2}} \right]}$$

$$F_{II}(s) = \frac{1.122 - 0.561s + 0.085s^2 + 0.180s^3}{\sqrt{1-s}}$$

Where $s = \frac{\xi}{h}$, ξ = crack depth during the process of penetrating from 0 to final depth(h).

Using Paris equation, $\delta_i = \frac{\partial \pi_c}{\partial P_i}$

$$C_{ij} = \frac{\partial \delta_i}{\partial P_j} = \frac{\partial^2 \pi_c}{\partial P_i \partial P_j}$$

$$C_{11} = \frac{2\pi}{E; b} \left[\frac{36L_c^2}{h^2} \int_0^{\frac{a}{h}} x F_1^2(x) dx \int_0^{\frac{a}{h}} x F_{11}^2(x) dx \right]$$

$$C_{12} = \frac{72\pi L_c}{E; b h^2} \int_0^{\frac{a}{h}} x F_1^2(x) dx = C_{21}$$

$$C_{22} = \frac{72\pi}{E; b h^2} \int_0^{\frac{a}{h}} x F_1^2(x) dx$$

$$C_{ovl} = \begin{bmatrix} C_{11} & C_{12} \\ C_{21} & C_{22} \end{bmatrix}$$

From flexibility method,

$$C_{intact} = \begin{bmatrix} \frac{L_e^3}{3EI} & \frac{L_e^2}{2EI} \\ \frac{L_e^2}{2EI} & \frac{L_e}{EI} \end{bmatrix}$$

$$C_{total} = C_{ovl} + C_{intact}$$

$$C_{total} = \begin{bmatrix} \frac{L_e^3}{3EI} + C_{11} & \frac{L_e^2}{2EI} + C_{12} \\ \frac{L_e^2}{2EI} + C_{12} & \frac{L_e}{EI} + C_{22} \end{bmatrix}$$

The stiffness matrix of the cracked element K_c from the principle of virtual work is given as,

$$K_c = [L][C_{total}]^{-1}[L]^T$$

$$\text{Where, } [L] = \begin{bmatrix} -1 & 0 \\ L_e & -1 \\ 1 & 0 \\ 0 & 1 \end{bmatrix}, L_e = \text{Length of beam}$$

$[M]\ddot{u} + [K]u = 0$ is the equation of motion for an undamped free vibration analysis of beam which is reduced to

$$[K_c] - \omega^2 [M_e] = 0$$

The mass matrix for an intact beam element is,

$$\text{Where } M_e = \text{Mass matrix of the element.} = \begin{bmatrix} 156 & 22L & 54 & -13L \\ 22L & 4L^2 & 13L & -3L^2 \\ 54 & 13L & 156 & -22L \\ -13L & -3L^2 & -22L & 4L^2 \end{bmatrix}$$

A computer program is developed to perform all the necessary computations in MATLAB environment.

Chapter 4

4. EXPERIMENTAL PROGRAMME

4.1. Introduction

This chapter presents the features of the experimental work carried out for the free vibration analysis of uniform and stepped beam with and without cracks. The material properties of the beam specimen, preparation of stepped beam, test setup and the procedure for the free vibration test is covered in this chapter.

4.2. Material properties

Material: Mild Steel

Modulus of Elasticity, $E = 210\text{GPa}$

Poisson's ratio, $\nu = 0.3$

Density, $\rho = 7850\text{ kg/m}^3$

4.3. Preparation of stepped beam

For the experimental work, the cracks were formed using saw cutter on the beam. To form the stepped beam specimen uniform beams of different areas were joined together by welding.

4.4. Test setup

Equipment for vibration test:

- Modal hammer (type 2302-5)



Figure 4.1 Modal Impact Hammer (type 2302-5)

Striking the impact hammer on any structure, an impulsive force is applied to the structure. The load cell present in the head of the hammer senses an equal and opposite force. An output cable is connected to the vibration analyzer through which the electrical signals are transmitted.

- Accelerometer (type 4507)



Figure 4.2 Accelerometer (type 4507)

The transducer used for the vibration measurement is the Accelerometer (type 4507). It has better frequency range and relatively robust. It is mounted upon the specimen with the help of bees wax.

- FFT Analyzer (Bruel Kajer FFT analyzer type .3560)



Figure 4.3 FFT Analyzer (Bruel Kajer FFT analyzer type .3560)

For processing and analyzing the signals from modal hammer and accelerometer, an electronic device used for the purpose is called FFT analyzer. FFT algorithm is used for the analysis of the electrical signals that provide the frequency amplitudes.

- Notebook with PULSE software.

This is the display unit which shows the FRF and coherence graph after the input data is analyzed. The peaks of FRF are the natural frequencies of the specimen.



Figure 4.4 Notebook with PULSE software.

➤ Specimens to be tested

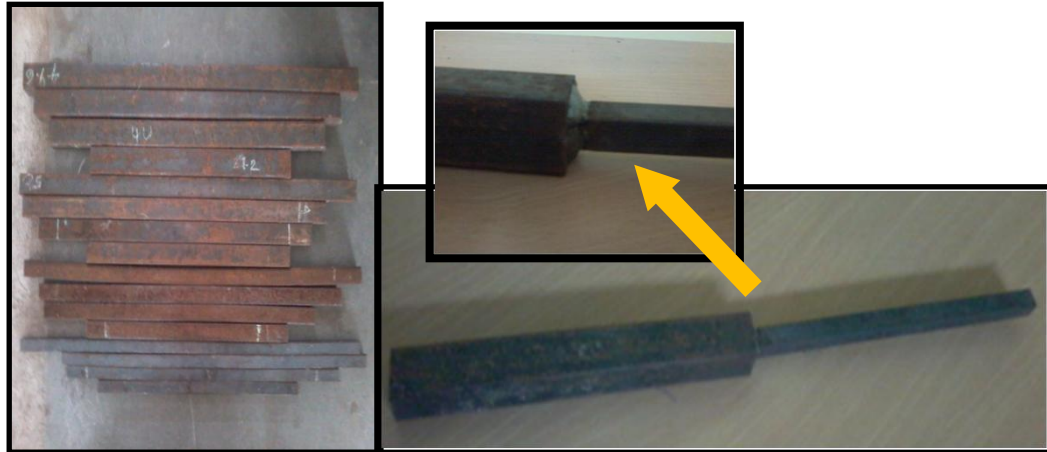

Figure 4.5 Uniform and Stepped beam specimens

4.5. Procedure for Free Vibration test

First, the beam specimen to be tested is arranged in the required boundary condition to the iron frame, if it is for cantilever else hanged through threads for free-free condition. All components of test setup, FFT analyzer, transducers, laptop, modal hammer and cables to the system are connected. To access the pulse software, the pulse lab shop version-10.0 software key is inserted into the port of the computer. With the help of bees wax, the accelerometer (B&K, Type 4507) is mounted on the specimen. The beam is excited in a selected point by means of small impact with an impact hammer (Model 2302-5). At the time of striking with a modal hammer at the points on the specimen, it should be seen that the stroke is perpendicular to the surface of the beams. The input signals are captured by a force transducer, fixed on the hammer. The resulting vibrations of the specimens on the selected point are sensed by an accelerometer. Then signal is processed by the FFT Analyzer and the frequency spectrum is also obtained. Both input and output signals are investigated by means of spectrum analyzer (Bruel & kajer) and resulting frequency response functions are transmitted to a computer for modal parameter extraction. The output from the analyzer is displayed on the analyzer screen. Various forms of frequency response functions (FRF) are directly measured. For FRF, at each

point the modal hammer is struck five times and the average value of the response is displayed on the screen of the display unit. Then by moving the cursor to the peaks of the FRF graph the frequencies are measured.



Figure 4.6 Free Vibration test setup, beam suspended by two strings like free-free beam, accelerometer and modal hammer in position



Figure 4.7 Vibration test setup for a cantilever beam with three cracks of uniform depth of 8mm present at $x_1=125\text{mm}$, $x_2=250\text{mm}$, $x_3= 345\text{mm}$

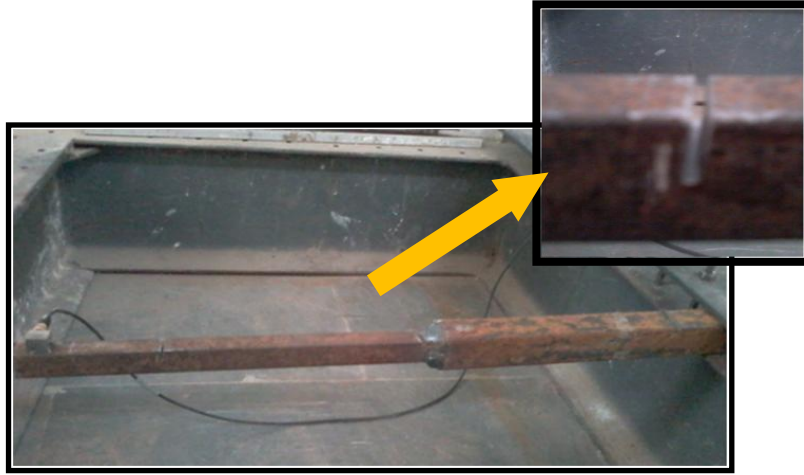

Figure 4.8 Vibration test setup for stepped beam with edge crack of depth 10mm located at $x=352\text{mm}$



Figure 4.9 Vibration test setup for a stepped beam suspended through strings to look like free-free beam.

Chapter 5

5. RESULTS AND DISCUSSIONS

5.1. Convergence study:

In this section, the convergence study is done to verify the accuracy of the present FEM analysis.

5.1.1. Uniform Cantilever Beam with crack.

The convergence study is done for the cantilever uniform beam of square cross-section with single crack with the case considered in **Lee et.al (2000)**. A 300mm cracked cantilever beam of cross section (20 x 20) mm with Young's modulus, $E= 206\text{GPa}$ and mass density, $\rho = 7750 \text{ kg/m}^3$. It is observed that convergence starts when the number of elements is 14 and convergence up to 30 numbers of elements, is shown in **Figure 5.1**. As per the convergence study, **20 elements** are considered for the discretization of whole structure.

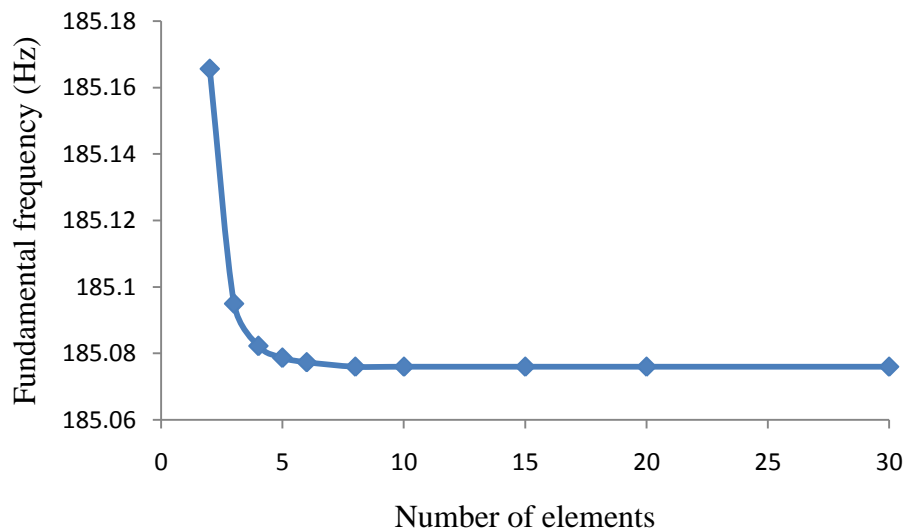

Figure 5.1 Convergence of fundamental frequency of uniform cantilever beam with single crack.

5.1.2. Two-stepped cantilever beam without crack

The convergence study for the two-stepped cantilever of rectangular cross-section is done with the case considered in **Zhang et.al (2009)**. The thickness of beam is 12mm. The material properties of the beam are modulus of elasticity, $E= 210\text{Gpa}$, length of beam, $L =500\text{mm}$, density, $\rho = 7860 \text{ kg/m}^3$, $h_1= 20\text{mm}$, $h_2 = 16\text{mm}$. It is observed that convergence starts when the number of mesh divisions is 10 and convergence up to 30 numbers of elements is shown in **Figure 5.2**. Hence for the present study for all stepped beams, mesh division of **30 elements** is considered.

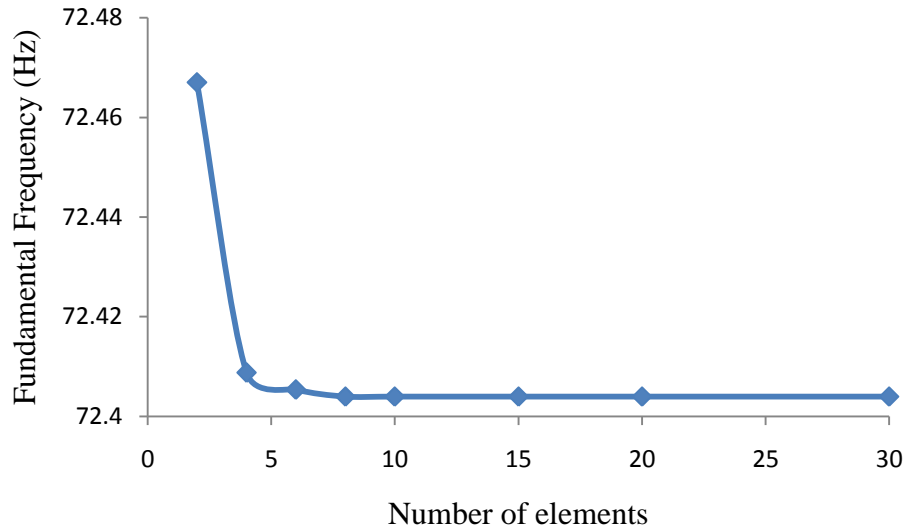

Figure 5.2 Convergence of fundamental frequency of Two- stepped cantilever beam of rectangular cross-section.

5.2. Comparison with previous study

5.2.1. Free Vibration Analysis of Cracked Uniform Cantilever Beam

The present FEM formulation is validated with literature. The variation of natural frequency with respect to the uniform cantilever beam with single crack is studied and compared with **Shiffrin (1999)** as shown in the **Table 5.1**.

The material properties of the beam are, Elastic modulus of the beam, $E = 210\text{MPa}$, Poisson's Ratio, $\nu = 0.3$, Density, $\rho = 7800 \text{ kg/m}^3$, Beam Width, $b = 0.02\text{m}$, Beam depth, $h = 0.02 \text{ m}$, Beam length, $L = 0.8\text{m}$, Position of the crack from clamped end $x_1 = 0.12\text{m}$, Crack depth $a_1 = 0.002 \text{ m}$.

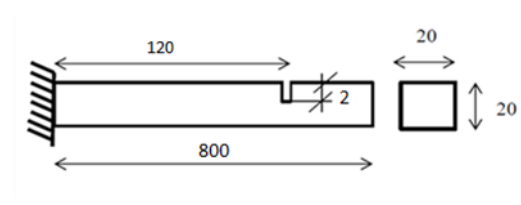

Figure 5.3 Cracked cantilever beam (mm)

Table 5.1 Comparison of natural frequency drawn between Shiffrin (1999) and present FEM analysis.

MODE	Natural Frequency (Hz) Shiffrin (1999)	Present analysis FEM (Hz)
MODE1	26.123	26.168
MODE2	164.092	164.109
MODE3	459.607	459.558

5.2.2. Free Vibration Analysis of Cracked Stepped Beams of Rectangular Cross-Section

The problem contains computation of natural frequencies for cracked Bernoulli-Euler Cantilever beam using Finite Element Analysis are validated with the results obtained by **Zhang et.al (2009)**. The thickness of beam is 12mm. The material properties of the beam are modulus of elasticity, $E= 210\text{Gpa}$, length of beam, $L =500\text{mm}$, density, $\rho = 7860 \text{ kg/m}^3$, $h_1= 20\text{mm}$, $h_2 = 16\text{mm}$.

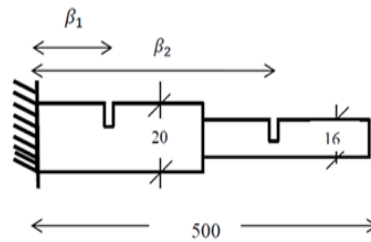

Figure 5.4 Cracked cantilever stepped beam (mm)

Table 5.2 Comparison of natural frequency drawn between Zhang et.al (2009) and present FEM analysis

	Crack1		Crack2		Natural frequency (Zhang et.al 2009)		Present analysis (FEM)	
	location β_1	depth ζ_1	location β_2	depth ζ_2	MODE1	MODE2	MODE1	MODE2
Case 1	-	-	-	-	72.40	373.61	72.40	373.65
Case2	-	-	0.6	0.25	72.138	365.67	72.129	365.75
Case3	0.1	0.2	0.6	0.2	70.736	365.42	70.576	365.40
Case4	0.25	0.25	0.6	0.3	70.368	355.06	70.68	355.06

5.3. Free vibration of uniform beam subjected to single crack

5.3.1. Uniform fixed-free beam

The geometrical properties of the beam shown in Fig 5.5 is carried out for free vibration analysis . The variation of non-dimensional first natural frequency with relative location of the crack (x/L) for different crack depths of the Fixed-Free beam is plotted in Fig5.6

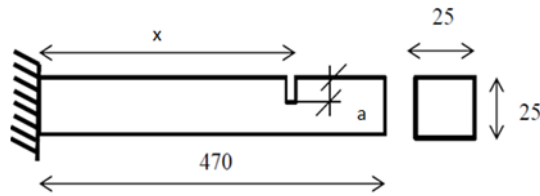

Figure 5.5 Cracked uniform beam

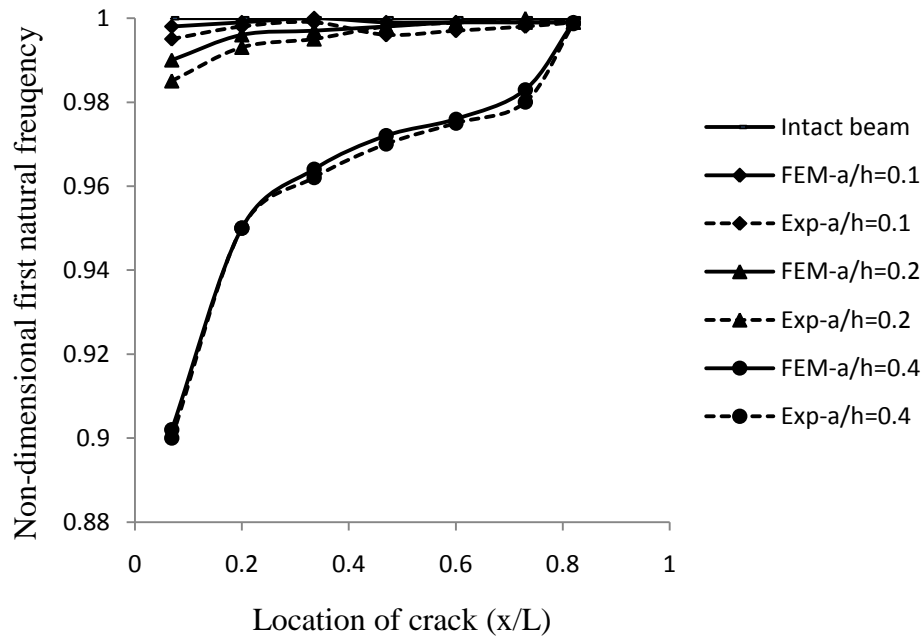

Figure 5.6 Comparison of FEM and experimental results for non-dimensional first natural frequencies of single cracked cantilever beam with location of crack (x/L) for varying crack depth ratios.

For all the different locations of crack considered, the fundamental frequency is more affected when crack is located at $x=0.0325L$, the first mode of non-dimensional frequency decreases by 0.15%, 0.92%, 9.70% compared to intact beam for the crack depth ratios 0.1,0.2,0.4

respectively. It is observed that as the crack position moves away from the fixed end, the non-dimensional first natural frequency increases and at the free end it is almost similar to intact beam. The effect of crack is effective when it is near to fixed end which could be made cleared by the fact that bending moment is maximum at the fixed end, thus, resulting in considerable loss of stiffness .Fig 5.7 shows a comparison of non-dimensional second natural frequencies of numerical and FEM, as a function of crack depth ratios for the crack positions considered experimentally and numerically.

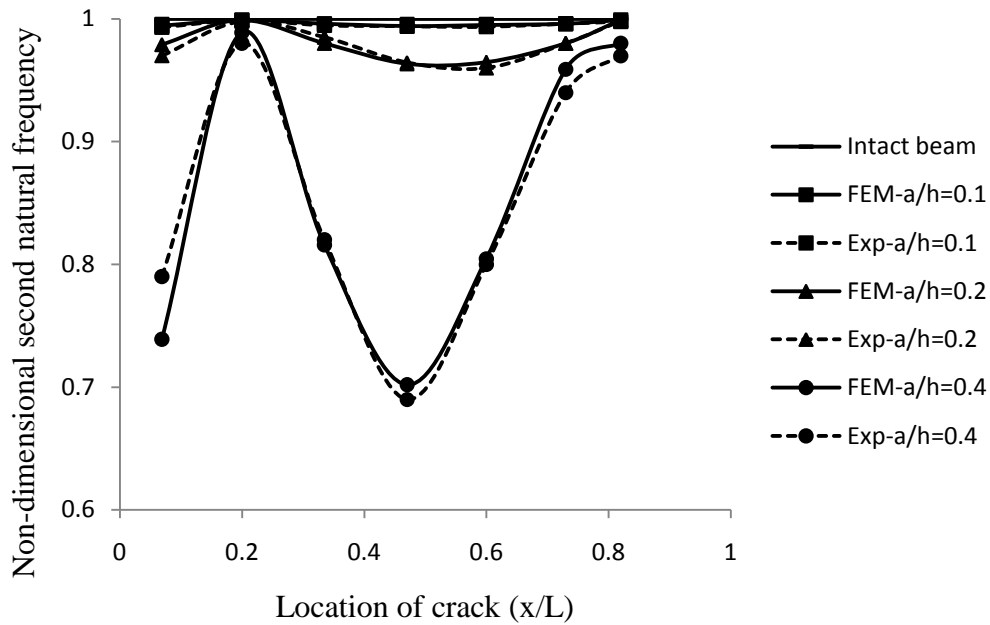

Figure 5.7 Comparison of FEM and experimental results for non-dimensional second natural frequencies of single cracked cantilever beam with location of crack (x/L) for varying crack depth ratios.

It is observed that the presence of crack has significant effect on the second mode non-dimensional frequency for all the cases of crack positions except for the crack location at ($x/L=0.20$). When the crack is located at $x/L=0.20$, the non-dimensional frequency of second mode is barely affected, the cause for this zero influence is that the nodal point for the second mode is located here. The crack located at $x/L=0.0325$ brings about 0.164%, 1.01%, 12.22% decrease in

second mode of non-dimensional frequency compared to intact beam for the crack depth ratios 0.1,0.2,0.4 respectively. It is also noticed that for the crack locations $x/L= 0.34$ to 0.85 , the second mode non-dimensional frequency is diminished from maximum. Fig 5.8 shows the plot of the variations in third mode non-dimensional frequency for different crack depths and crack locations considered for experimental and numerical study.

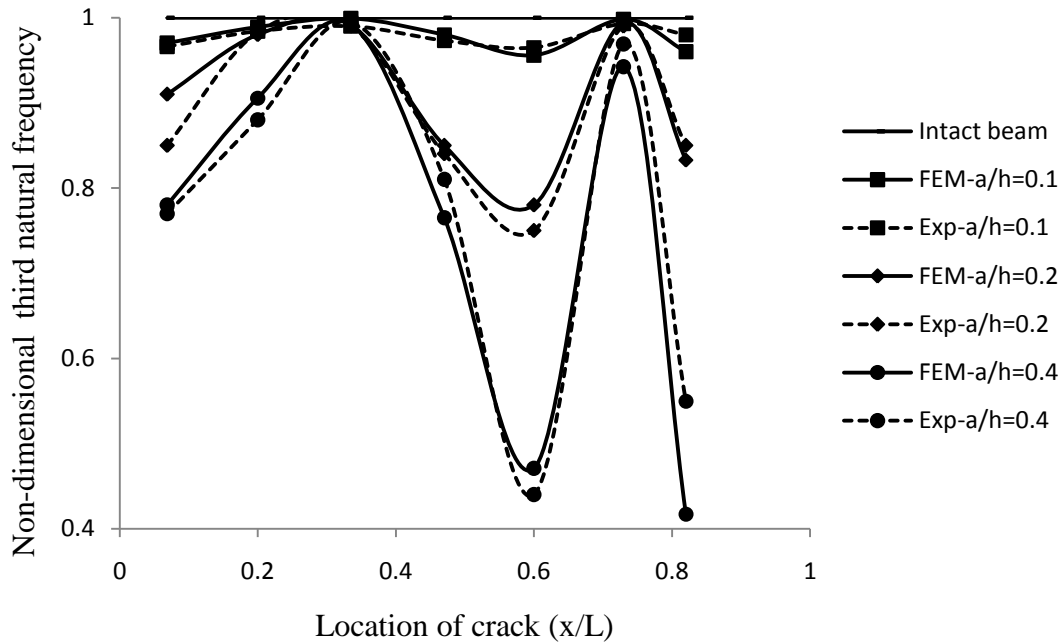

Figure 5.8 Comparison of FEM and experimental results for non-dimensional third natural frequencies of single cracked cantilever beam with location of crack (x/L) for varying crack depth ratios.

From the plot, it can be inferred that for crack locations, $x/L=0.60$, a drastic change in the third mode of non-dimensional natural frequency occurs. When the crack is located at $x/L = 0.0325$, the non-dimensional frequency decreases by 0.34%, 2.13%, 18.41% compared to intact beam for the crack depth ratios 0.1,0.2,0.4 respectively. And it is also observed that for $x/L = 0.375, 0.734$ due to existence of nodal points, the reduction is slightly noticed. The effect of crack near fixed and free ends of the beam on the third mode non-dimensional natural frequency has very less effect.

5.3.2. Uniform free-free beam

Free vibration analysis of uniform beam with free ends is carried out. The geometrical properties of the beam is shown in Fig5.9. A comparison of numerical and FEM natural frequencies ratios of first mode for various crack locations for different crack depths along the beam is shown in Fig 5.10.

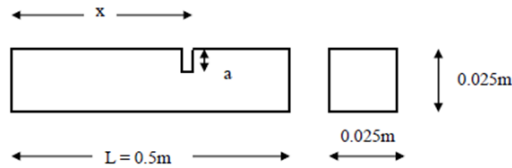

Figure 5.9 Uniform Beam with Crack (mm)

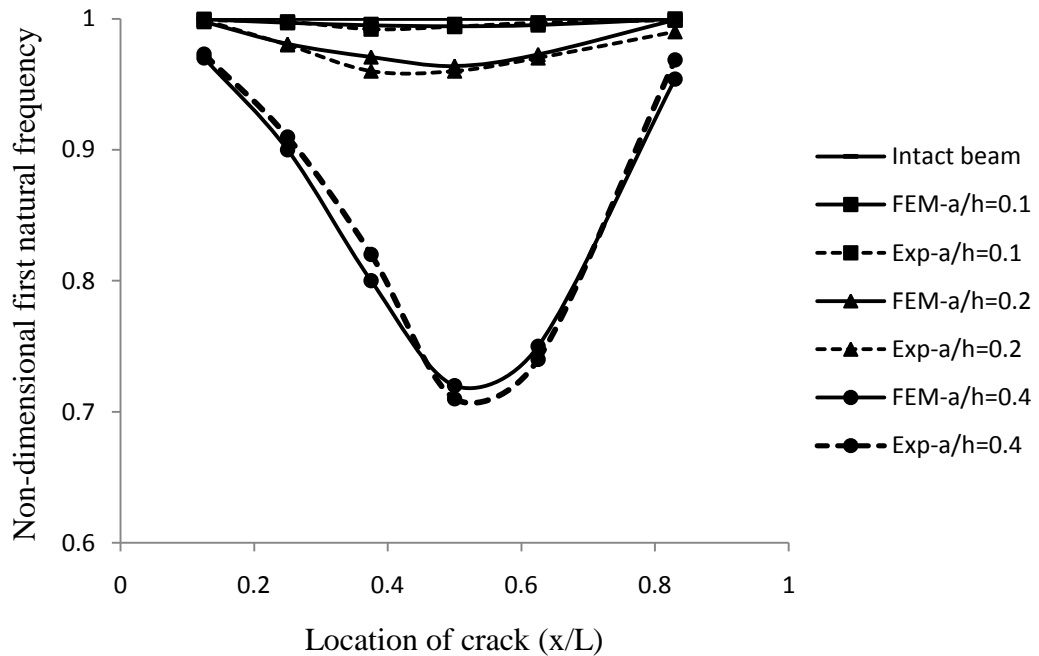

Figure 5.10 Comparison of FEM and experimental results for non-dimensional first natural frequencies of single cracked free-free beam with location of crack (x/L) for varying crack depth ratios.

It is observed that the first mode of non-dimensional frequencies is more affected when the crack is located at $x/L=0.5$. When the crack is located at $x/L= 0.25$ and 0.82 , the decrease in

the non-dimensional frequency is in range of 0.15%, 0.92%, 9.7% for 0.1, 0.2, 0.4 crack depth ratios. This indicates that the first mode non-dimensional frequency is least affected when present near the free ends, but as the crack location varies the maximum affect is in the middle of the beam and it increases as the crack depth ratio increases. The variation of non-dimensional frequency of second mode for various crack locations for different crack depths, experimentally and numerically are shown in Fig 5.11

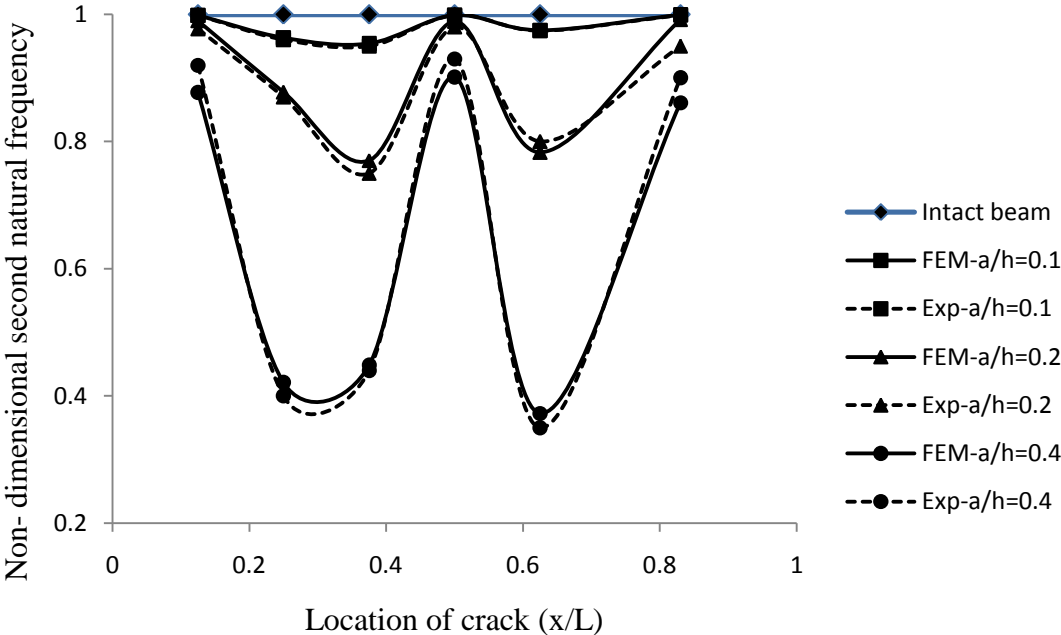

Figure 5.11 Comparison of FEM and experimental results for non-dimensional second natural frequencies of single cracked free-free beam with location of crack (x/L) for varying crack depth ratios

It is observed that the second mode non-dimensional frequencies is least affected when the crack is located at mid span i.e. $x/L=0.5$. The non-dimensional frequencies of second mode for crack locations, $x/L = 0.25, 0.375, 0.625$ positions for crack depths 0.1, 0.2, 0.4 considerable decrease than intact beam is noted. When the crack is located at free ends and mid span, the second mode non-dimensional frequency is least affected which is due to the presence of node

points at those locations. The effect of crack for different locations and crack depths on third mode non-dimensional frequency is shown in Fig 5.12

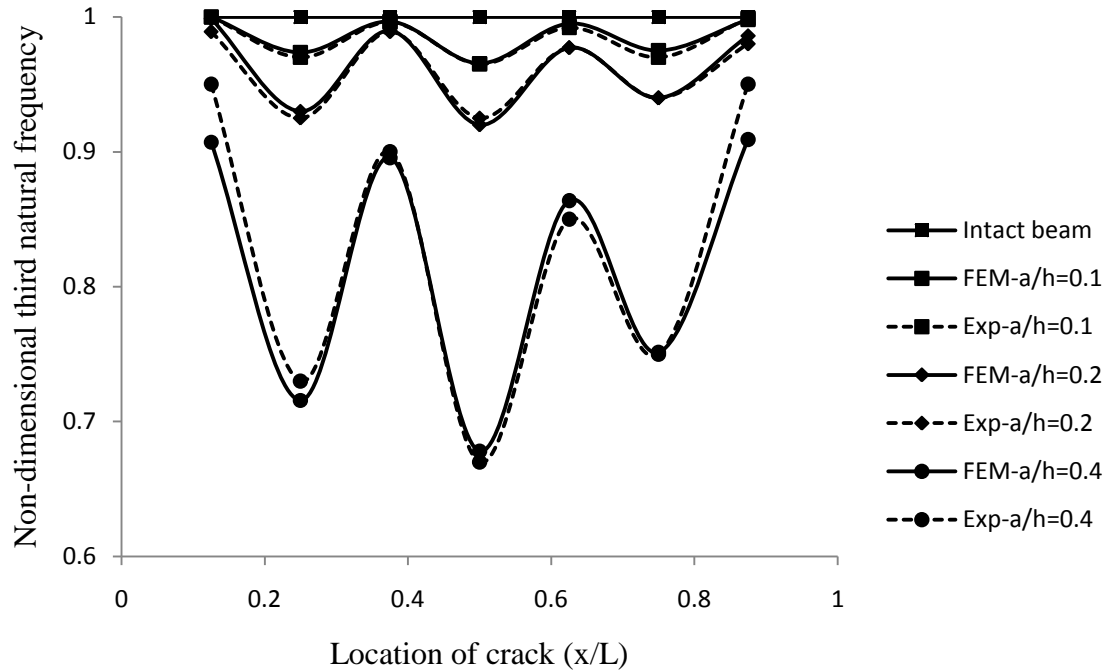

Figure 5.12 Comparison of FEM and experimental results for non-dimensional first natural frequencies of single cracked free-free beam with location of crack (x/L) for varying crack depth ratios.

Referring to Fig 5.12, it can be concluded that the third mode non-dimensional frequencies decrease by 0.45%, 2.7%, 19.13% when the crack is located at $x/L = 0.25, 0.5, 0.75$ for different crack depths 0.1, 0.2, 0.4 respectively.

5.4. Free Vibration of uniform beam subjected to double cracks

5.4.1. Uniform fixed-free

Variation of non-dimensional frequencies for first three modes for different locations of crack with varying crack depths are studied experimentally and numerically for fixed-free boundary condition. The schematic diagram of the beam, indicating the geometrical properties

along with different locations of crack considered for the study is shown in Fig 5.13. Fig 5.14 illustrates the non-dimensional first natural frequencies as function of crack depth ratios for different crack locations.

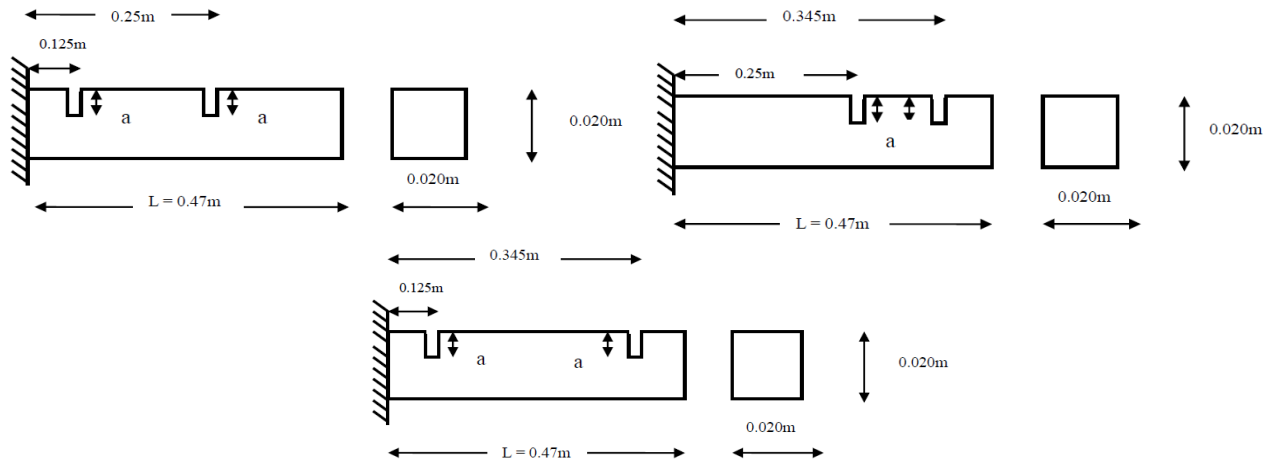

Figure 5.13 Sketch of uniform cantilever beam with two cracks considered at different locations for the present study.

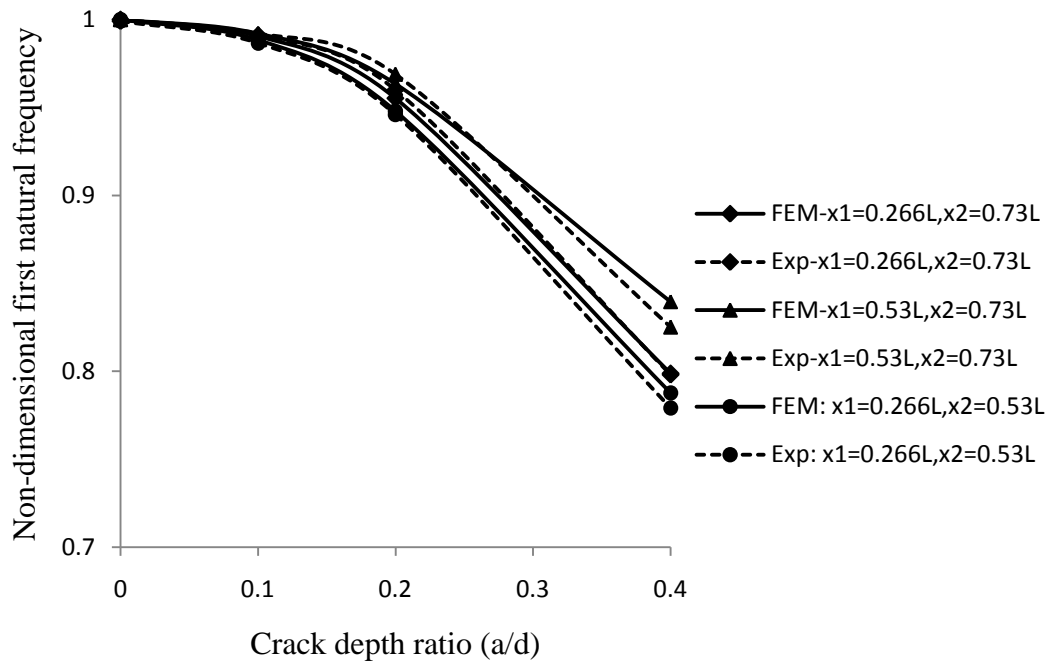

Figure 5.14 Comparison of FEM and experimental results for non-dimensional first natural frequencies of double cracked fixed-free beam with crack depth ratio (a/d) for different locations of crack.

It can be obviously seen from Fig 5.14 that with the increase in crack depth ratio , the frequency reduction increases. The results attained by present analysis, FEM are compared with those of experimental and as is noticed from Fig 5.14, good concurrence has been found between the results. As observable from the Fig 5.14, the second frequency reduction is higher when the crack is located at $x_1=0.266L, x_2=0.53L$, a decrease of 1.16%, 5.2%, 21.23% is noted for the 0.1,0.2,0.4 crack depth ratios respectively. The first non-dimensional frequencies is least effected when the crack locations are present far away from the fixed end that is $x_1=0.53L, x_2=0.73L$, a decrease of 0.94% ,4.46%, 21.17 % for crack depth ratios 0.1, 0.2, 0.4 is observed. With the first crack position at $x_1=0.266L$ being constant and the position of second crack is varied away from the fixed end , $x_2=0.73L$, the effect of crack is meager than the crack locations at $x_1=0.266L, x_2=0.53L$, 0.81%, 3.66%, 15.96% decrease for 0.1, 0.2, 0.4 crack depth ratios respectively is observed. Comparison drawn between the FEM and experimental results for variation of non-dimensional second natural frequency for different crack locations for 0.1, 0.2, 0.4 crack depth ratios is demonstrated in Fig 5.15.

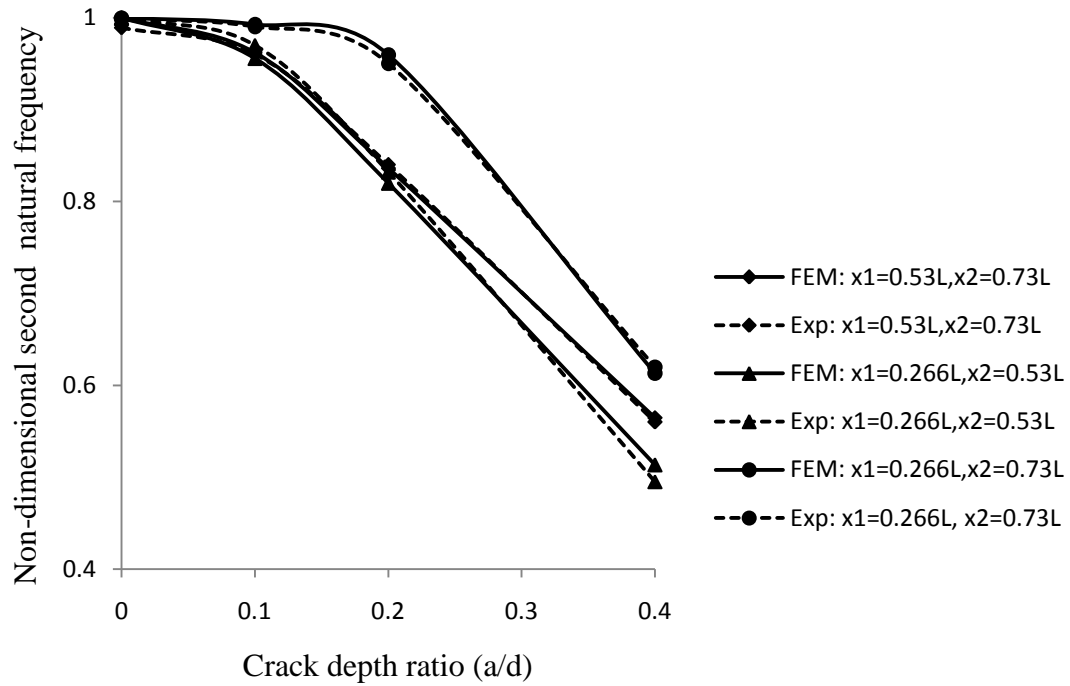

Figure 5.15 Comparison of FEM and experimental results for non-dimensional second natural frequencies of double cracked fixed-free beam with crack depth ratio (a/d) for different locations of crack.

From Fig 5.15, it can be discerned that the greater drops in the non-dimensional second natural frequencies occur when the cracks are positioned at $x_1=0.266L$, $x_2=0.53L$, decrease of 4.36%, 18.02%, 48.28% for 0.1, 0.2, 0.4 crack depth ratios is observed. If the position of second crack is changed from $x_2=0.266L$ to $x_2=0.73L$, the natural frequency in second mode is hardly affected. The decrease in non-dimensional second natural frequency is 0.75%, 4.05%, 38.71% when compared to the intact beam for 0.1, 0.2, 0.4 crack depth ratios respectively. Fig 5.16 displays the variation of third non-dimensional natural frequency for different crack locations for 0.1, 0.2, 0.4 crack depth ratios.

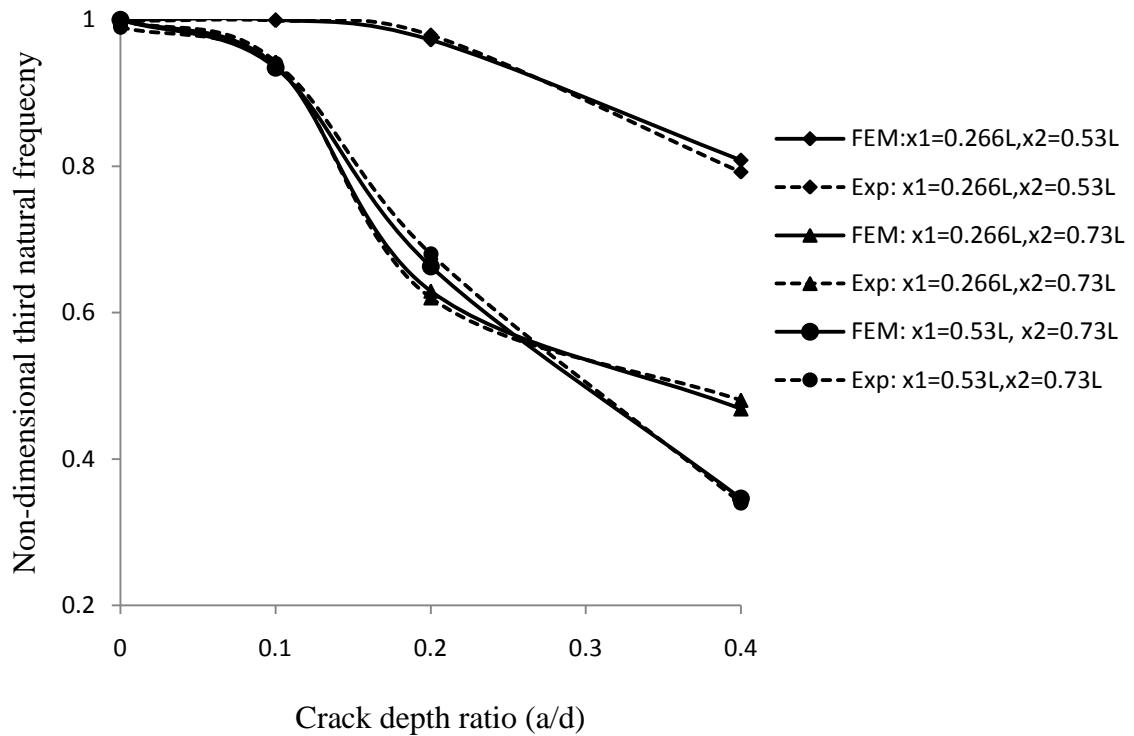

Figure 5.16 Comparison of FEM and experimental results for non-dimensional third natural frequencies of double cracked fixed-free beam with crack depth ratio (a/d) for different locations of crack.

Referring to the Fig 5.16 , it is clear that for crack positions at $x_1=0.266L$, $x_2=0.53L$, the natural frequency in the third mode is hardly affected, a decrease of 0.002%, 0.0278%, 19.01% when compared to that of the intact beam is noted for 0.1, 0.2, 0.4 crack depth ratios. The effect of double cracks located at $x_1=0.53L$, $x_2=0.73L$ shows a decrease of 6.55%, 37.03%, 65.40% when compared to the intact beam for 0.1, 0.2, 0.4 crack depth ratios respectively.

5.4.2. Uniform free-free beam

Free vibration analysis of beam with double cracks is carried out for different crack depths as considered in Fig 5.17. The variation of non-dimensional first natural frequency for two cracks is plotted for different crack locations and a different crack depth ratio is shown in Fig 5.18.

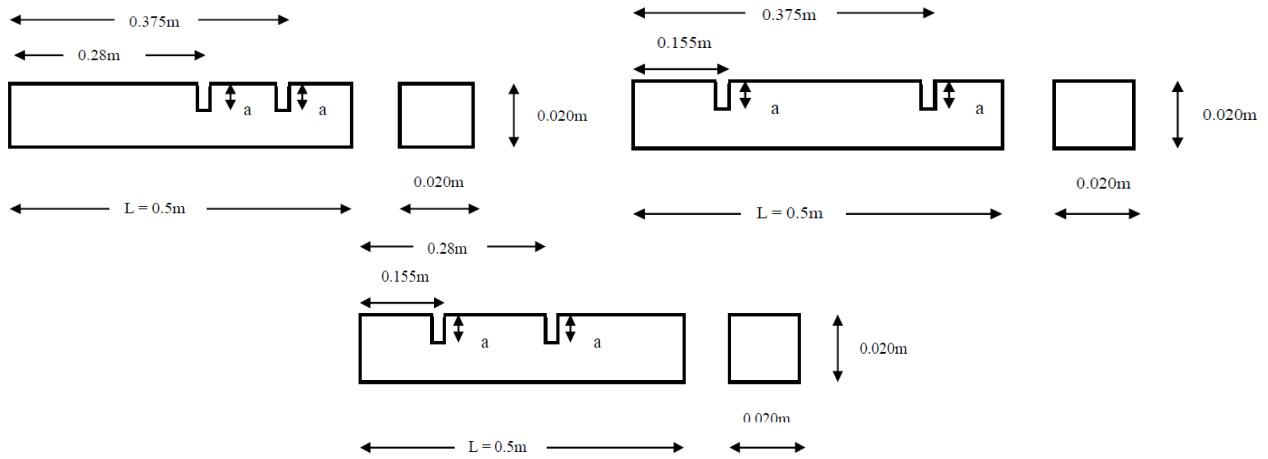

Figure 5.17 Sketch of uniform free-free beam with two cracks considered at different locations for the present study.

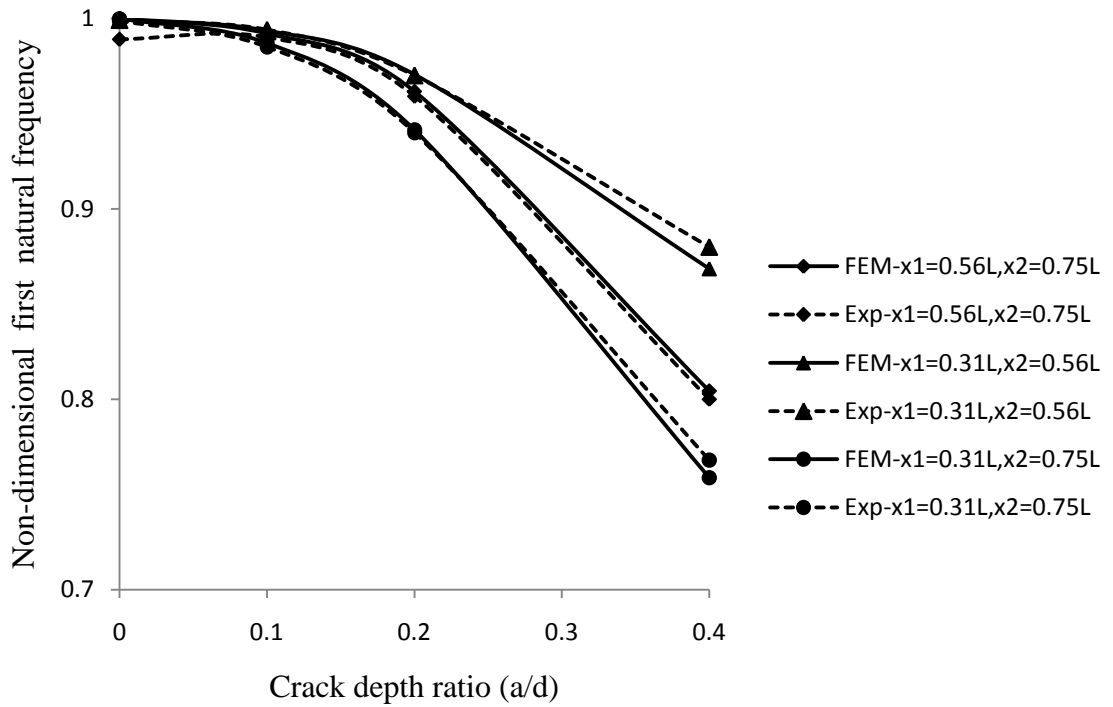

Figure 5.18 Comparison of FEM and experimental results for non-dimensional first natural frequencies of double cracked free-free beam with crack depth ratio (a/d) for different locations of crack.

It can be observed that the non-dimensional first natural frequency is very less affected when the cracks are located at $x_1=0.31L, x_2=0.56L$, the decrease in the natural frequencies is 0.65%, 2.95%, 13.15% with respect to the intact beam respectively. Crack located near the free

ends that is $x_1=0.31L, x_2=0.75L$ reduces the non-dimensional first natural frequencies by 1.30%, 5.86%, 24.12% than intact beam for crack depth ratios 0.1, 0.2, 0.4 respectively. Up to the crack depth ratios 0.1, 0.2 the reduction in non-dimensional frequencies for cracks located at $x_1= 0.56L, x_2= 0.75L$ and $x_1=0.31L, x_2=0.56L$ is marginal. The variation of non-dimensional second natural frequency with different depths of crack for various crack locations is shown in Fig 5.19

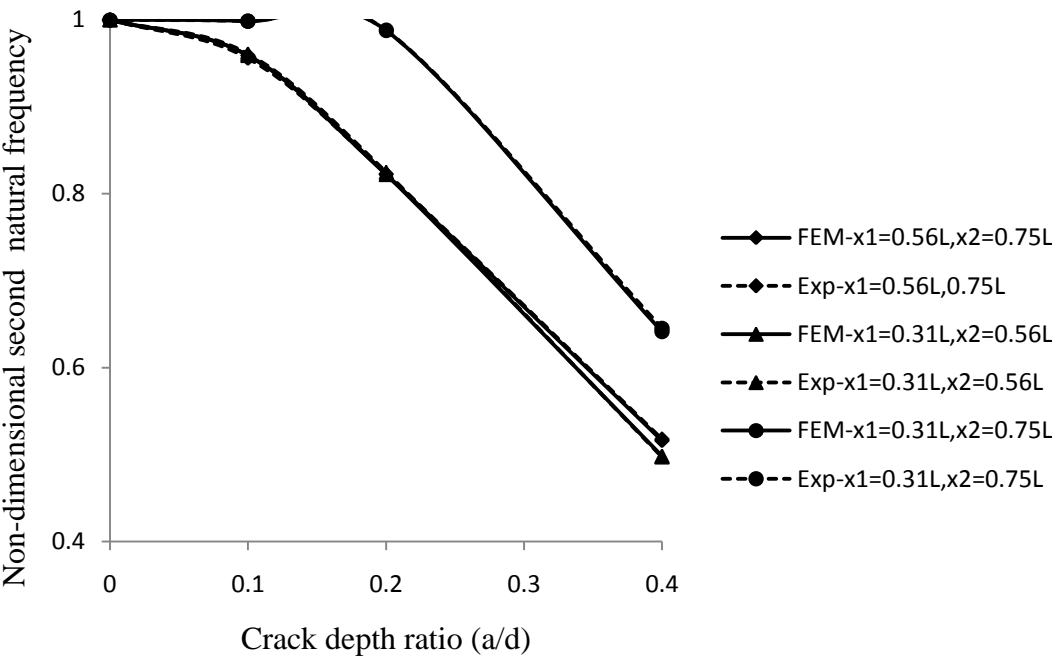

Figure 5.19 Comparison of FEM and experimental results for non-dimensional second natural frequencies of double cracked free-free beam with crack depth ratio (a/d) for different locations of crack.

Referring to Fig 5.19, it is observed that the non-dimensional second natural frequency is least affected when the cracks are present near the free ends. Keeping one of the crack location constant at 0.56L and the second crack located at either of end of beam, the decrease in non-dimensional second natural frequency is almost the same. A decrease of 4.11%, 17.80%, 50.17% is noted when cracks are located at $x_1=0.31L, x_2=0.56L$ for 0.1, 0.2, 0.4 crack depth ratios.

Similarly variation of non-dimensional third natural frequency with different crack depths for different locations of crack is shown in Fig 5.20

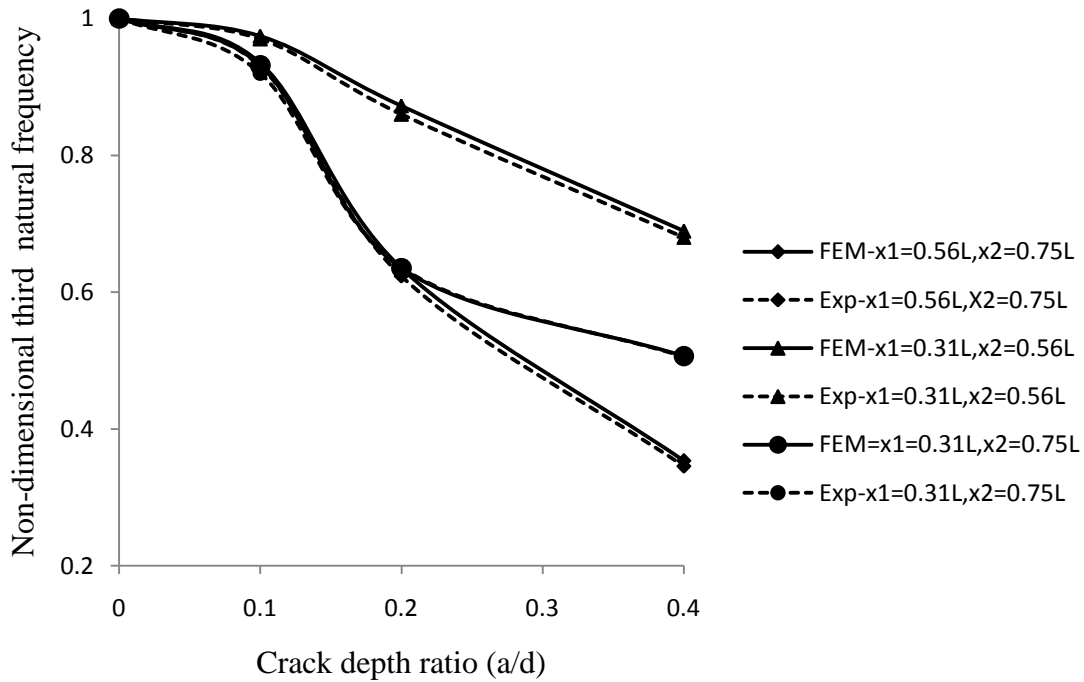

Figure 5.20 Comparison of FEM and experimental results for non-dimensional third natural frequencies of double cracked free-free beam with crack depth ratio (a/d) for different locations of crack.

It is observed that the non-dimensional third natural frequency is affected more when the cracks are located at $x_1=0.56L, x_2=0.75L$, a decrease of 6.52%, 36.5%, 64.66% compared to intact beam is noticed for 0.1, 0.2, 0.4 crack depth ratios respectively.

5.5. Free Vibration of uniform beam subjected to triple cracks

5.5.1. Uniform free-free

The affect of triple cracks on the free vibration of a beam is studied experimentally and the plots showing the validation of experimental results with numerical results are presented. The different locations of cracks considered for the study is illustrated in the Fig 5.21 for free –free

boundary condition. A comparison drawn between the FEM and numerical results for first mode of non- dimensional natural frequency is shown in the Fig 5.22

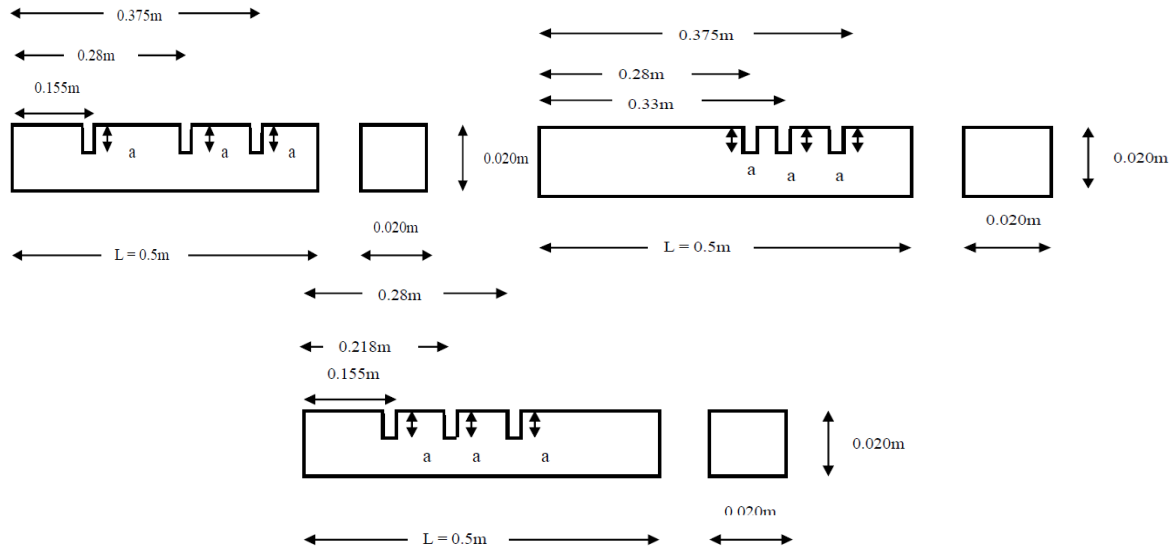

Figure 5.21 Sketch of uniform cantilever beam with three cracks considered at different locations for the present study.

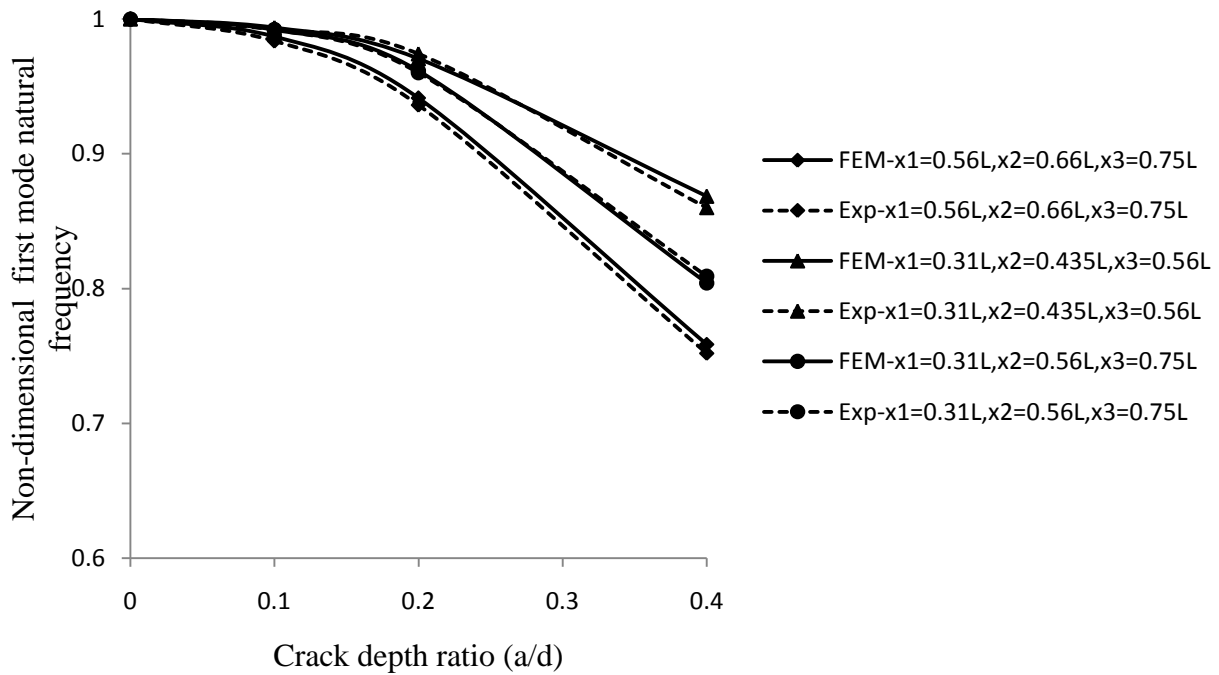

Figure 5.22 Comparison of FEM and experimental results for non-dimensional first natural frequencies of triple cracked free-free beam with crack depth ratio (a/d) for different locations of crack.

From Fig 5.22, it can be noted that the reduction is more in the case of cracks located at $x_1=0.56L, x_2=0.66L, x_3=0.75L$, a decrease of 1.15%, 5.52%, 26.20% when compared to the intact beam is observed. Next, it is inferred from Fig 5.22 that for the cracks located at $x_1=0.31L, x_2=0.435L, x_3=0.56L$, 1.09%, 4.91%, 20.54% reduction in the non-dimensional first natural frequencies when compared to the intact beam is observed. And also significant reduction is observed if the three cracks are located at $x_1=0.31L, x_2=0.56L, x_3=0.75L$. Fig 5.23 shows a comparison second mode non-dimensional natural frequencies of numerical and FEM, as a function of crack depth ratios for the crack positions considered experimentally and numerically.

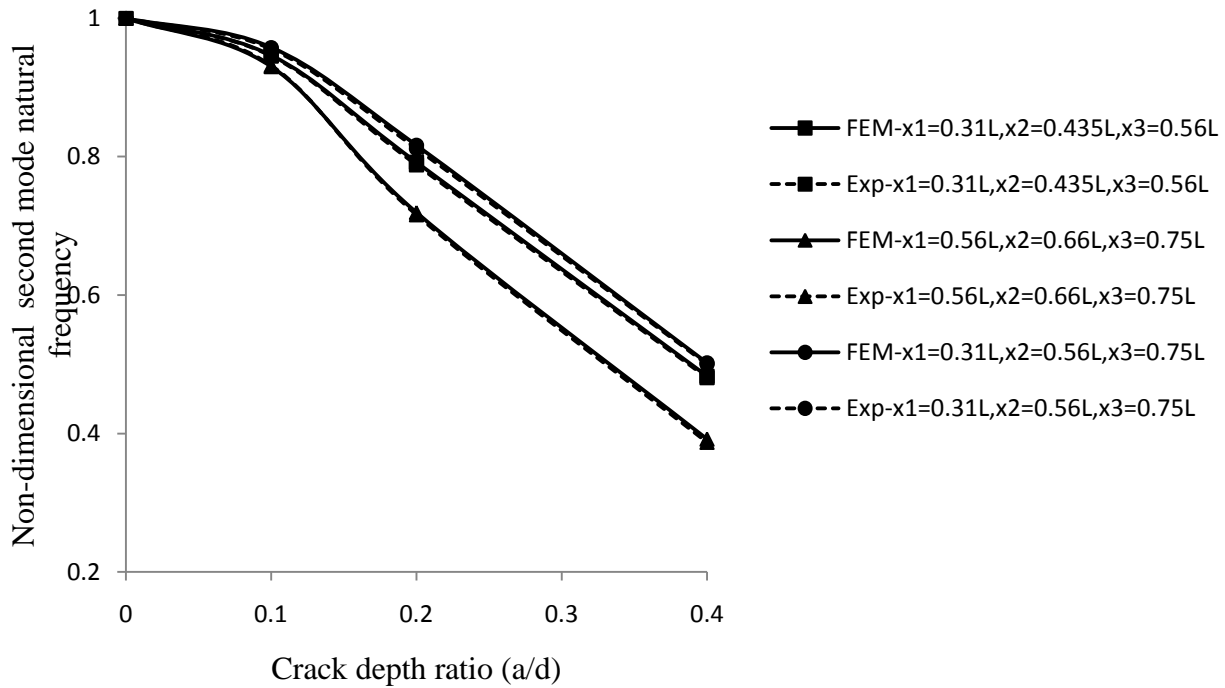

Figure 5.23 Comparison of FEM and experimental results for non-dimensional second natural frequencies of triple cracked free-free beam with crack depth ratio (a/d) for different locations of crack.

From the plot, it can be inferred that the second mode non-dimensional frequencies are more effected by 6.98%, 28.05%, 60.78% compared to the intact beam when the cracks are located at $x_1=0.56L, x_2=0.66L, x_3=0.75L$ for crack depth ratios 0.1, 0.2, 0.4 respectively. The

non-dimensional second natural frequencies is less affected when compared to intact beam when any one of the crack location is near the free end, it is observed clearly from the plot that for crack locations $x_1=0.31L$, $x_2=0.435L$, $x_3=0.56L$ and $x_1=0.31L$, $x_2=0.56L$, $x_3=0.75L$, the drop in the natural frequencies is comparatively less for the crack depth ratios 0.1, 0.2, 0.4. The plot (fig 5.24) depicts a comparison of non-dimensional third natural frequencies of numerical and FEM as a function of crack depth ratios for different crack positions.

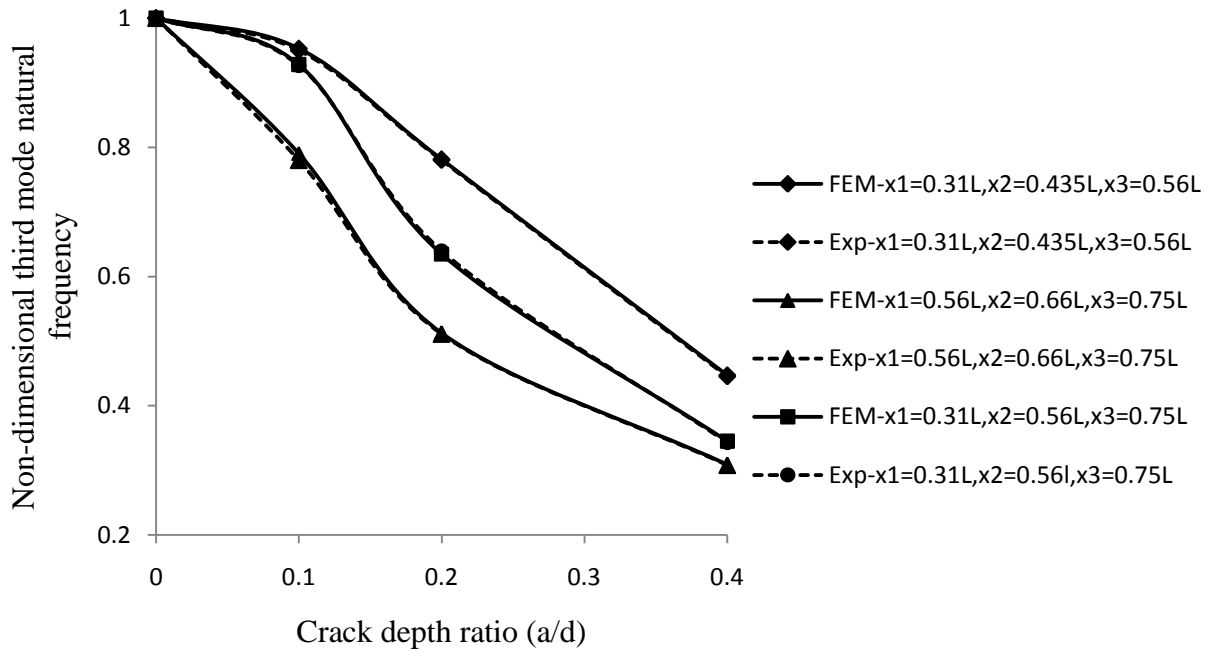

Figure 5.24 Comparison of FEM and experimental results for non-dimensional third natural frequencies of triple cracked free-free beam with crack depth ratio (a/d) for different locations of crack.

Referring to the Fig 5.24, it can be concluded that the third mode of non-dimensional natural frequencies is more effected when the cracks are located at $x_1=0.56L$, $x_2=0.66L$, $x_3=0.75L$ when compared to the intact beam for 0.1, 0.2, 0.4 crack depth ratios respectively.

5.5.2. Uniform fixed-free

Free vibration analysis for a beam with fixed –free boundary condition in the presence of multiple cracks is carried out for the varying crack locations is displayed in Fig 5.25. The plot of variation of first mode natural frequencies as function of different crack depth ratios for the different positions of cracks is shown in the Fig 5.26.

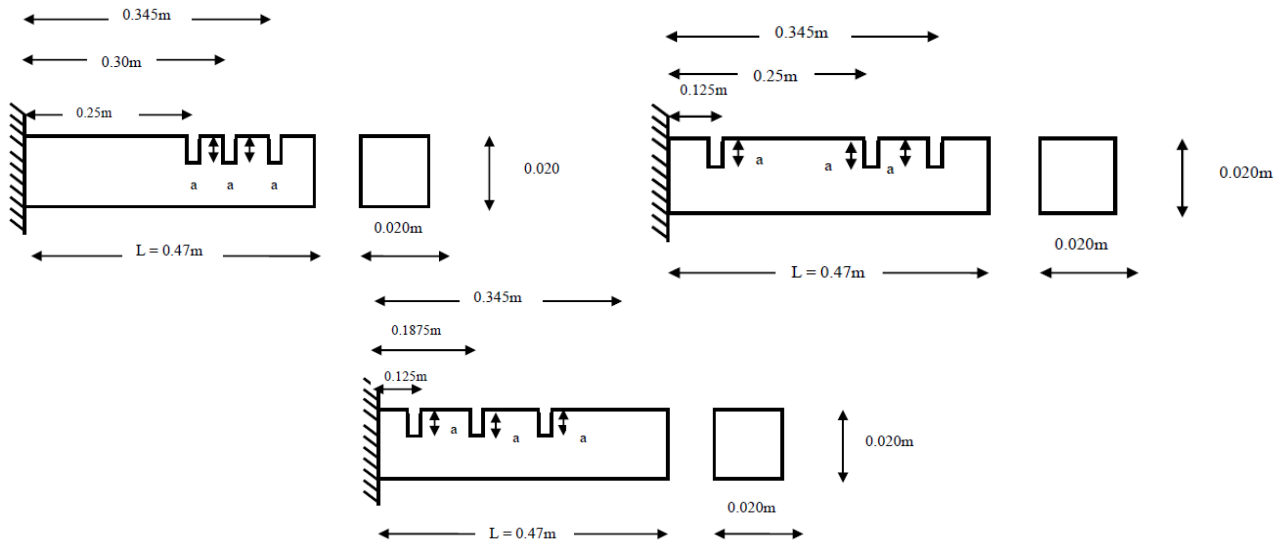

Figure 5.25 Sketch of uniform cantilever beam with three cracks considered at different locations for the present study.

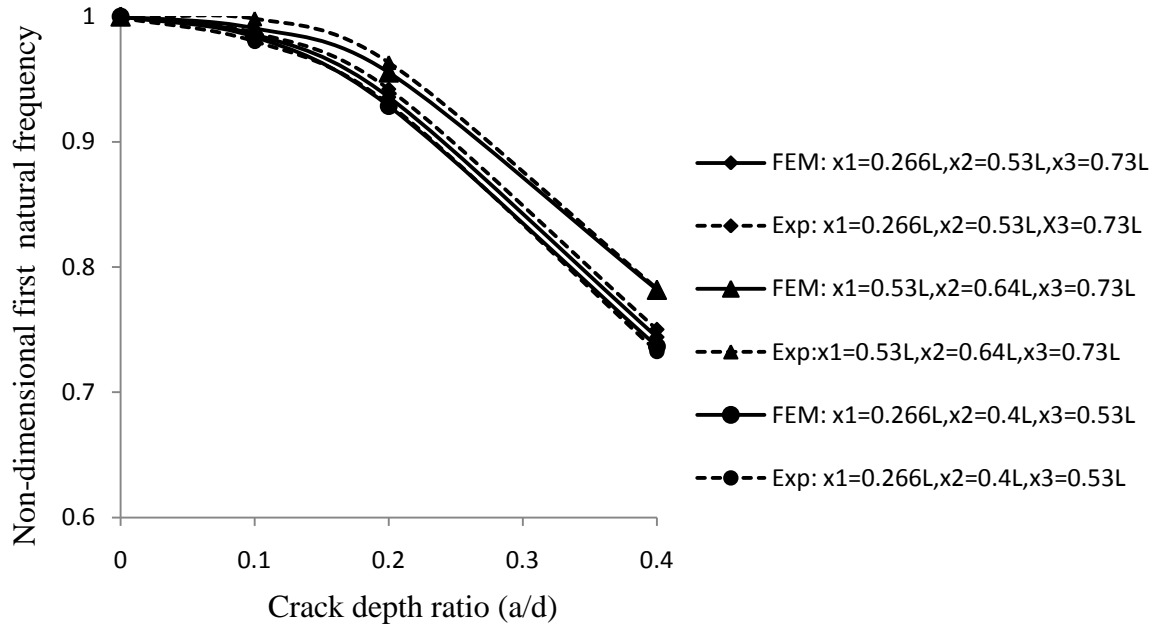

Figure 5.26 Comparison of FEM and experimental results for non-dimensional first natural frequencies of triple cracked fixed-free beam with crack depth ratio (a/d) for different locations of crack.

Fig 5.26 illustrate that the reduction in the non-dimensional first natural frequencies is higher when the cracks are located at $x_1 = 0.266L$, $x_2 = 0.4L$, $x_3 = 0.53L$, a reduction of 1.65%, 7.15%, 26.33% when compared to the intact beam for the 0.1, 0.2, 0.4 crack depth ratios is noticed. The effect in the first mode non-dimensional frequencies is meager when the crack locations are away from the fixed end that is $x_1 = 0.53L$, $x_2 = 0.64L$, $x_3 = 0.73L$, a decrease of 0.944%, 4.68%, 22.19% is observed when compared to the intact beam for 0.1, 0.2, 0.4 crack depth ratios respectively. A decrease of 1.45%, 6.44%, 25.60% compared to the intact beam is marked for the crack location $x_1 = 0.266L$, $x_2 = 0.53L$, $x_3 = 0.73L$ for the crack depth ratios 0.1, 0.2, 0.4 respectively. Fig 5.27 demonstrates the comparison of non-dimensional third natural frequencies for different crack depth ratios for different crack locations considered for the numerical and experimental study.

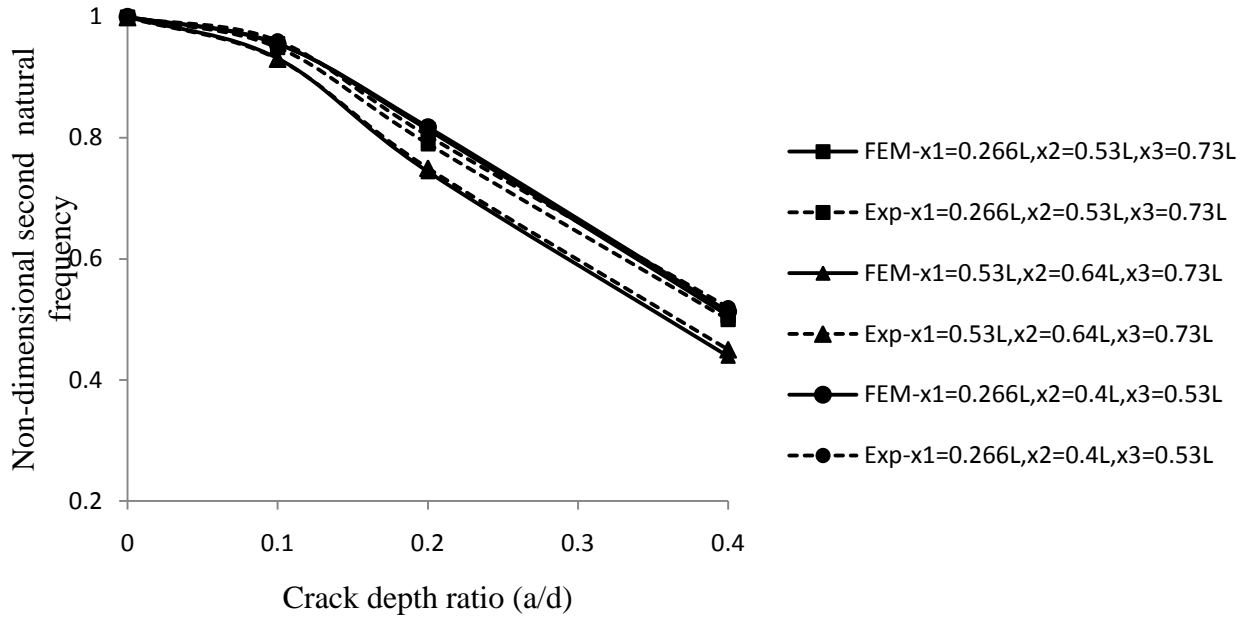

Figure 5.27 Comparison of FEM and experimental results for non-dimensional second natural frequencies of triple cracked fixed-free beam with crack depth ratio (a/d) for different locations of crack.

It is clear from Fig 5.27, similar trends in reduction of non-dimensional second natural frequencies is observed for the cracks located at $x_1=0.266L, x_2=0.53L, x_3=0.73L$ and $x_1=0.266L, x_2=0.4L, x_3=0.53L$, the range of decrease is (4.45- 4.51)%, (18.26-18.69)%, (48.70-49.36)% for 0.1, 0.2, 0.4 crack depth ratios respectively. From Fig 5.27, it is also noticed that for the crack locations at $x_1=0.53L, x_2=0.64L, x_3=0.73L$ for crack depth ratios 0.1, 0.2, 0.4 respectively decreases the normalized second mode natural frequencies by 6.88%, 21.90%, 53.20% compared to that of intact beam. Due to the presence of the nodal point at $x=0.2L$, the natural frequency in the second mode is less affected when the any of the crack is located near the fixed end (vicinity of the nodal point). Fig 5.28 indicates the variation of non-dimensional third natural frequencies for 0.1, 0.2, 0.4 crack depth ratios for different crack locations.

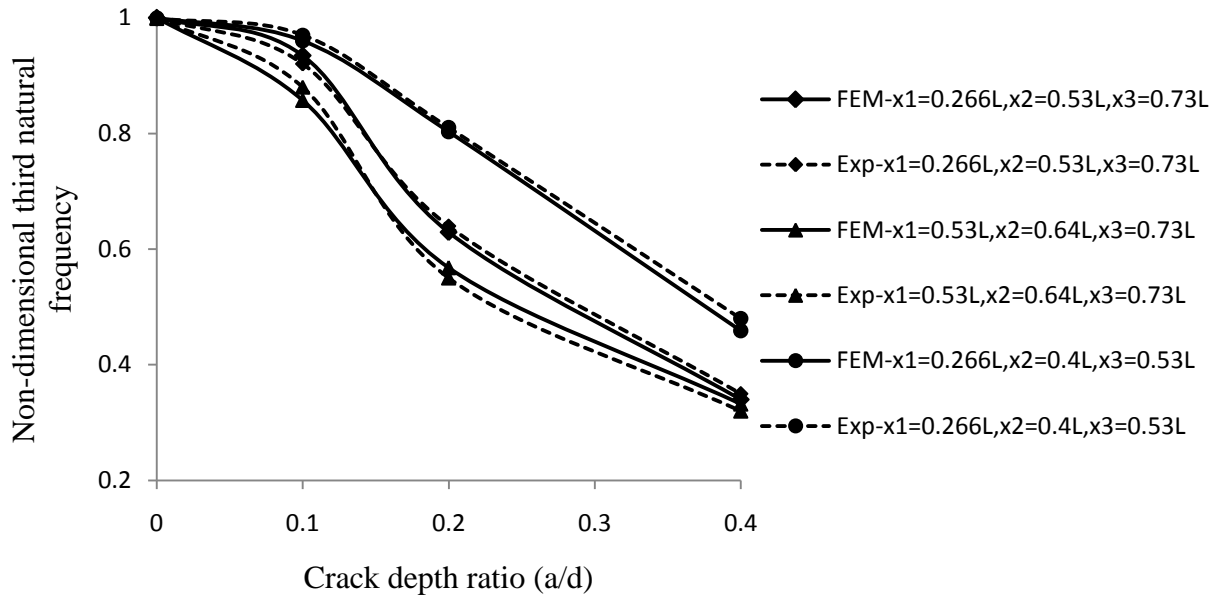

Figure 5.28 Comparison of FEM and experimental results for non-dimensional third natural frequencies of triple cracked fixed-free beam with crack depth ratio (a/d) for different locations of crack.

It is inferred from the Fig 5.28 that there is greater fall in the non-dimensional third natural frequencies when the cracks are located at $x_1=0.53L$, $x_2=0.64L$, $x_3=0.73L$, a decrease of 14.30%, 43.22%, 66.78% compared to intact beam for 0.1, 0.2, 0.4 crack depth ratios is observed. Cracks present closer to the nodal points (have smaller effect of the non-dimensional third natural frequency. Due to the presence of cracks($x_1= 0.266L$, $x_2= 0.4L$, $x_3=0.53L$) in the vicinity of the nodal points($x/L= 0.375$, 0.734), the decrease in the natural frequencies compared to the intact beam is comparatively less. A reduction of 4%, 19.69%, 54.11% when compared to intact beam for 0.1, 0.2, 0.4 crack depth ratios respectively is noticed for the cracks located at $x_1= 0.266L$, $x_2= 0.4L$, $x_3=0.53L$.

5.6. Free vibration of Stepped beam subjected to single crack

5.6.1. Cantilever stepped beam

The affect of crack in stepped beam is studied experimentally and the results obtained are compared with the Present (FEM) analysis, a good agreement has been found between the results. The schematic diagram (Fig 5.29) displays the geometrical properties of the stepped beam that is used for the study. Fig 5.30 demonstrates the non-dimensional first natural frequencies as function of crack depth ratios for several crack locations considered.

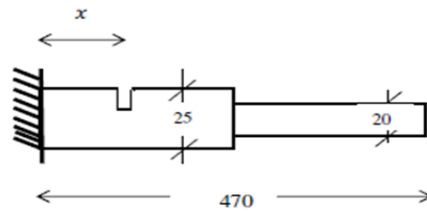

Figure 5.29 Cantilever Stepped beam (in mm)

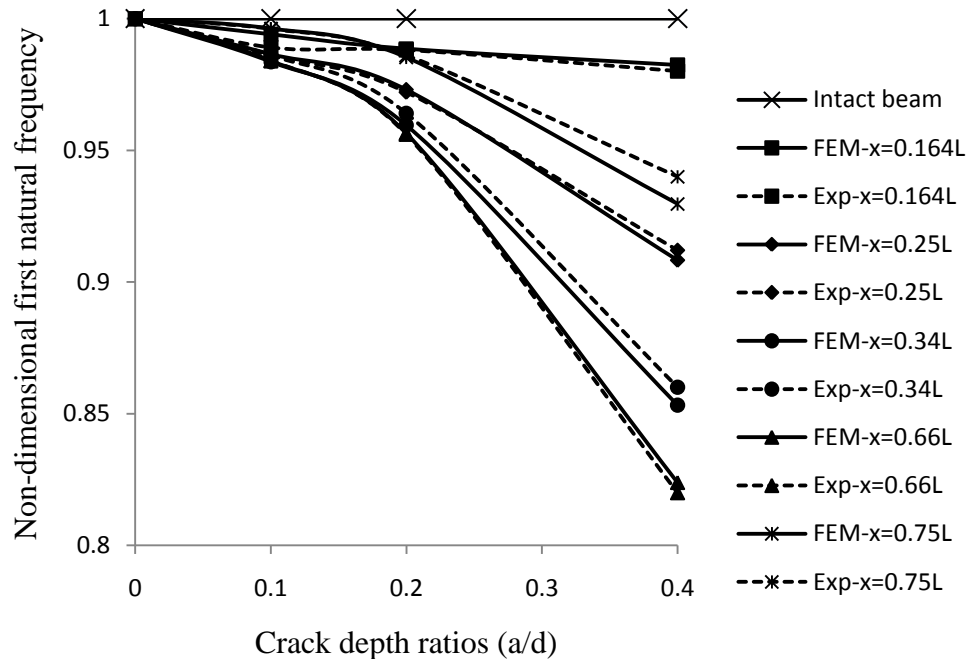

Figure 5.30 Comparison of FEM and experimental results for non-dimensional first natural frequencies of single cracked cantilever stepped beam with location of crack (x/L) for varying crack depth ratios.

From the Fig 5.30, it can be observed that greater drops in the non-dimensional first natural frequencies have occurred when the crack is located in the vicinity of step, $x=0.34L$ and $0.66L$ which could be explained by the reason that the stepped variation in the cross sectional reduces the stiffness of the beam along with the presence of crack near step. A decrease of 0.4%, 2.41%, 8.25% when compared to the intact stepped beam for 0.1, 0.2, 0.4 crack depth ratios are observed. When crack is situated near the fixed end, the non-dimensional first natural frequencies are barely affected. The non-dimensional second natural frequencies as function of crack depth for cracks situated at different positions are illustrated in Fig 5.31.

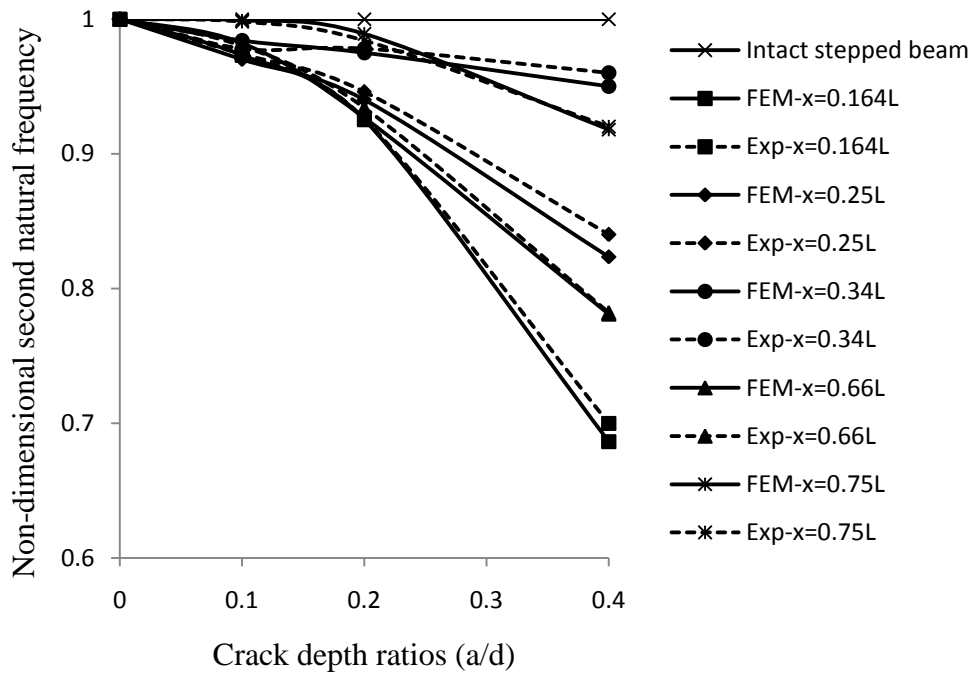

Figure 5.31 Comparison of FEM and experimental results for non-dimensional second natural frequencies of single cracked cantilever stepped beam with location of crack (x/L) for varying crack depth ratios.

From the Fig 5.31, it can be seen that when the crack is located near the fixed end the reduction in the non-dimensional second natural frequency is highest. A decrease of 0.05%, 0.315%, 12.30% when compared to intact stepped beam for 0.1, 0.2, 0.4 crack depth

ratios are observed for $x=0.164L$. Fig 5.32 displays the non-dimensional third natural frequency variation for different locations with 0.1, 0.2, 0.4 crack depth ratios.

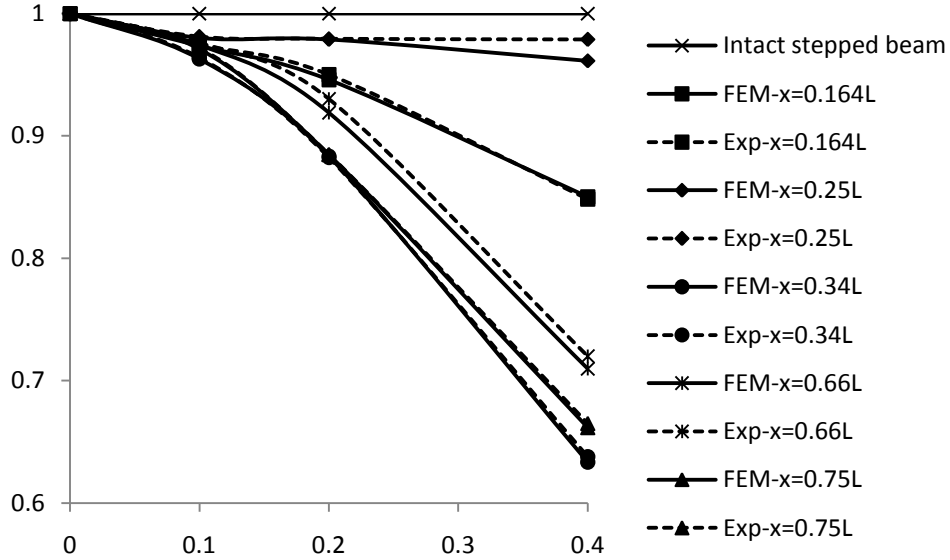

Figure 5.32 Comparison of FEM and experimental results for non-dimensional third natural frequencies of single cracked cantilever stepped beam with location of crack (x/L) for varying crack depth ratios.

Referring to Fig 5.32, it can be observed that when crack is positioned at step part the reduction in the non-dimensional third natural frequency is significant 0.7%, 3.4%, 15.26% decrease is noticed compared to the intact stepped beam as the crack depths ratios vary as 0.1, 0.2, and 0.4.

5.6.2. Free-free stepped beam

Free vibration analysis of stepped beam subjected to free –free condition in the presence of crack is studied both experimentally and numerically. The geometrical properties of the stepped beam utilized for the present study is shown in Fig 5.33. Fig 5.34 demonstrates the comparison drawn between the FEM and numerical results of the stepped beam subjected to single crack at various locations with crack depth ratio varying as 0.1, 0.2, and 0.4.

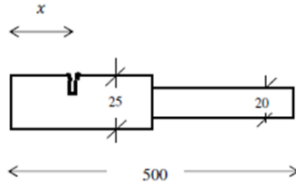

Figure 5.33 Free-Free stepped beam with crack (in mm)

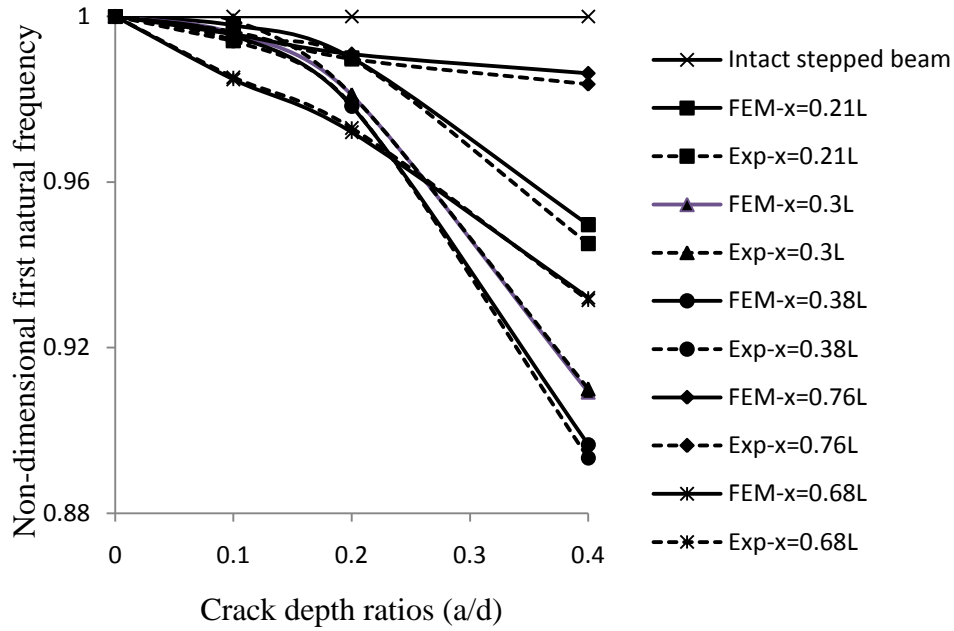

Figure 5.34 Comparison of FEM and experimental results for non-dimensional first natural frequencies of single cracked free-free stepped beam with location of crack (x/L) for varying crack depth ratios.

From Fig 5.34, it can be concluded that crack present near the step, $x=0.38L$ reduces the non-dimensional natural frequencies to much more extent than other position of crack. Higher decrease is noticed when the crack is located at $x=0.38L$ for 0.1, 0.2, and 0.4 crack depth ratios. The presence of crack at the free ends, $x=0.76L$ and $x=0.21L$, the natural frequencies is affected less. The variation in non-dimensional second natural frequencies for the presence of crack at various locations with different crack depth ratios (0.1, 0.2, and 0.4) is depicted in Fig 5.35.

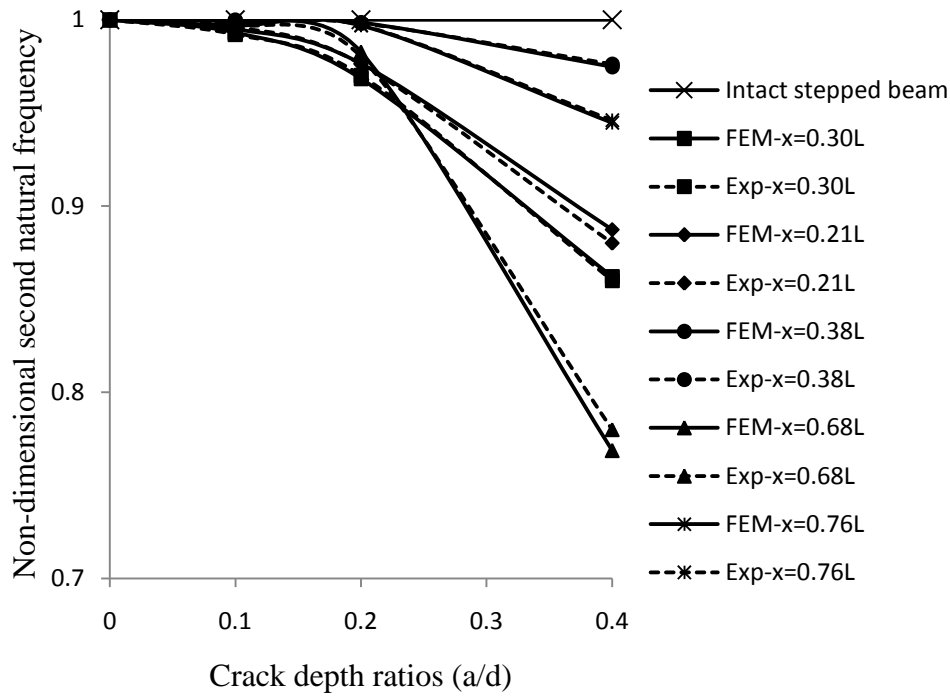

Figure 5.35 Comparison of FEM and experimental results for non-dimensional second natural frequencies of single cracked free-free stepped beam with location of crack (x/L) for varying crack depth ratios.

It can be inferred from Fig 5.35 that when cracks are located near free ends and at mid-span, $x=0.21L$, $0.38L$, $0.76L$, the second natural frequencies are least affected. A considerable decrease is noticed when the crack is located at $x=0.30L$ and $x=0.68L$, 0.3%, 2%, 10.4% when compared to intact stepped beam for 0.1, 0.2, 0.4 crack depth ratios. Fig 5.36 illustrates the comparison of FEM and experimental study of non-dimensional third natural frequencies as crack location varies from one free end to other with varying crack depth ratios.

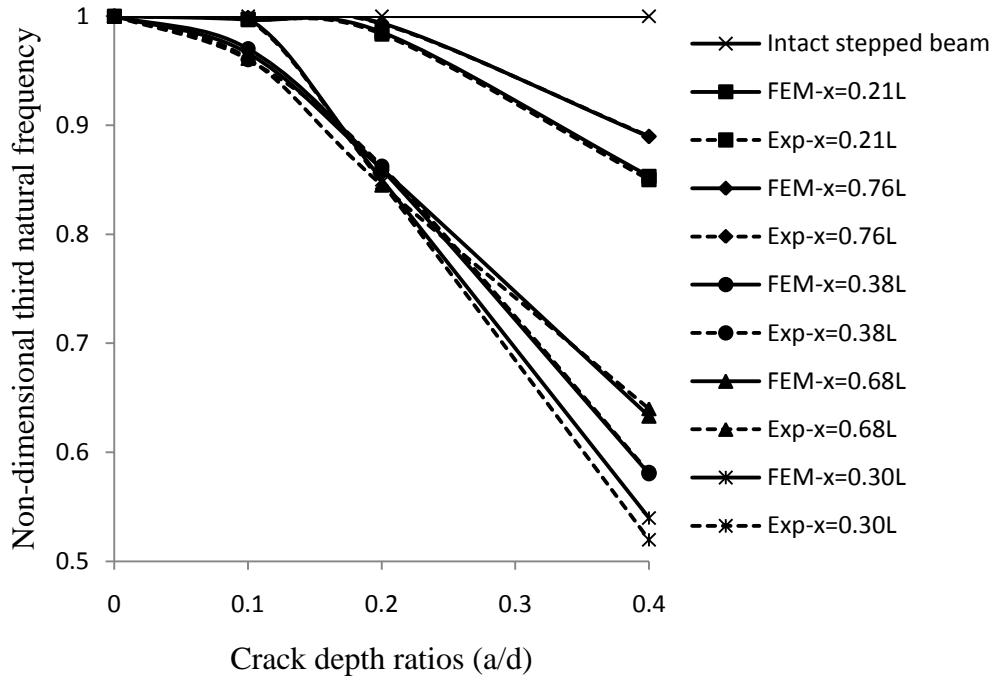

Figure 5.36 Comparison of FEM and experimental results for non-dimensional third natural frequencies of single cracked free-free stepped beam with location of crack (x/L) for varying crack depth ratios.

Referring to Fig 5.36, it can be noticed that cracks when located at $x=0.30L$, $0.38L$, $0.68L$, significant decrease in the non-dimensional third natural frequencies occurs. The decrease is 0.32%, 15.27%, 38% when position of crack is at $x=0.30L$ for 0.1, 0.2, and 0.4 crack depth ratios when compared with the intact stepped beam.

5.7. Free vibration of Stepped beam subjected to double crack

5.7.1. Free-free stepped beam

Free vibration analysis for the stepped beam in the presence of two cracks is carried out experimentally and accuracy is validated with the present (FEM) analysis. Different locations of cracks considered for the study is illustrated in Fig 5.37. The plot showing the variation of non-

dimensional first natural frequency for the different positions of cracks considered is given in Fig 5.38.

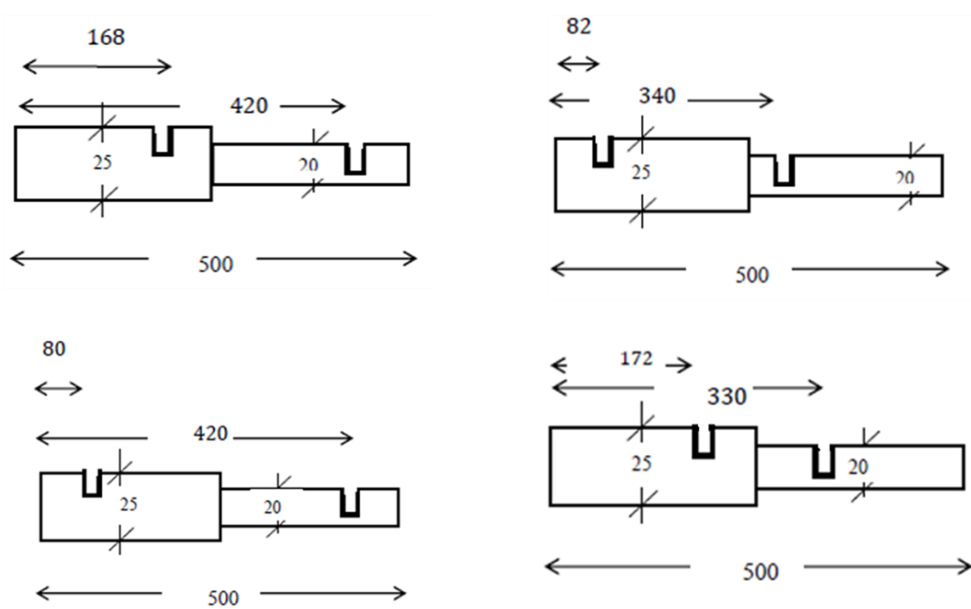

Figure 5.37 Sketch of stepped free-free beam with two cracks considered at different locations for the present study.

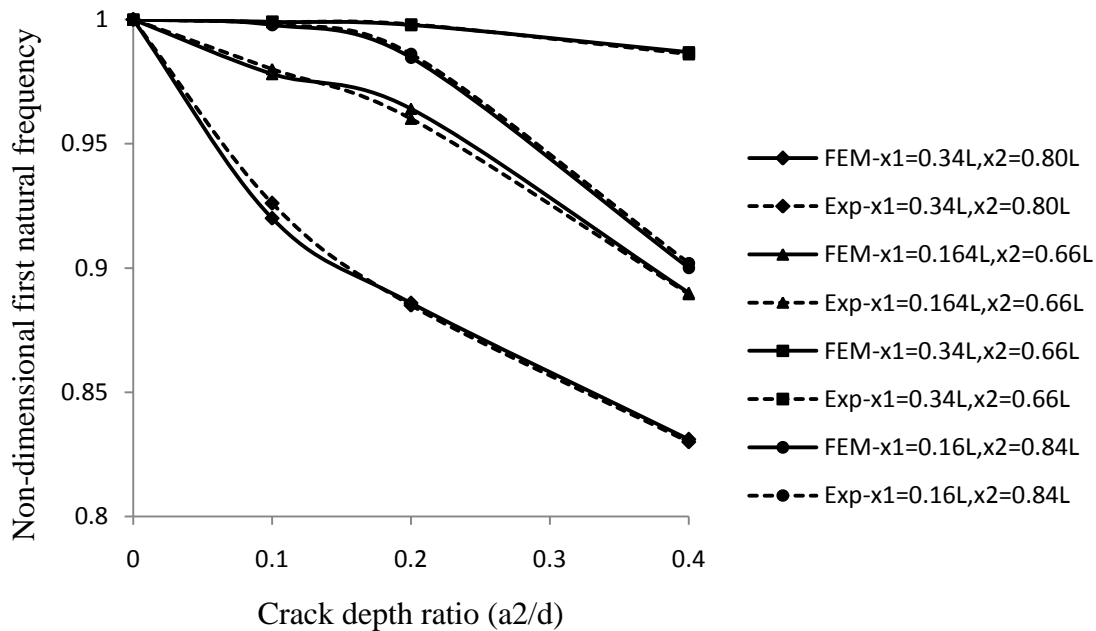

Figure 5.38 Comparison of FEM and experimental results for non-dimensional first natural frequencies of double cracked free-free stepped beam with varying crack depth ratios for different locations of crack.

Referring to Fig 5.38, it can be observed that high fall in non-dimensional first mode natural frequencies is when the cracks are located at $x_1=0.34L, x_2=0.80L$, 7.4%, 11.5%, 17% decrease when compared to the intact stepped beam is found. It can be also noted that when any of the two cracks is located in the higher step brings more reduction in the natural frequency and upon varying the position of crack from free end of the higher step to the step location, reduction level goes on increasing. Fig 5.39 illustrates the non-dimensional second natural frequency varying for different crack depth ratios at different locations considered for the study.

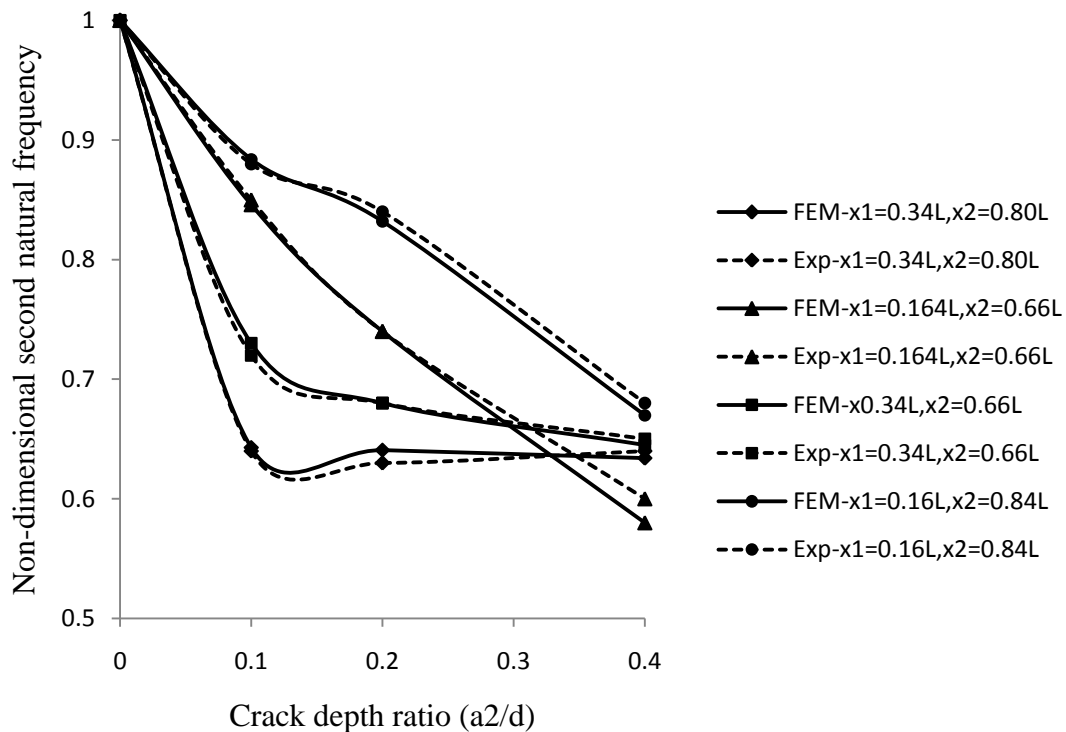

Figure 5.39 Comparison of FEM and experimental results for non-dimensional second natural frequencies of double cracked free-free stepped beam with varying crack depth ratios for different locations of crack.

Fig 5.39 depicts that the non-dimensional second natural frequencies decrease more when the cracks are located at $x_1=0.164L, x_2=0.66L$, 15.4%, 26%, 42% reduction when compared to intact stepped beam is noticed. The location of cracks one near the vicinity of step in higher step

and other varying in the lower step brings ($x_1=0.34L, x_2=0.80L$; $x_1=0.34L, x_2=0.66L$) reduces the natural frequency by 36% when compared to the intact stepped beam for 0.4 crack depth ratio.

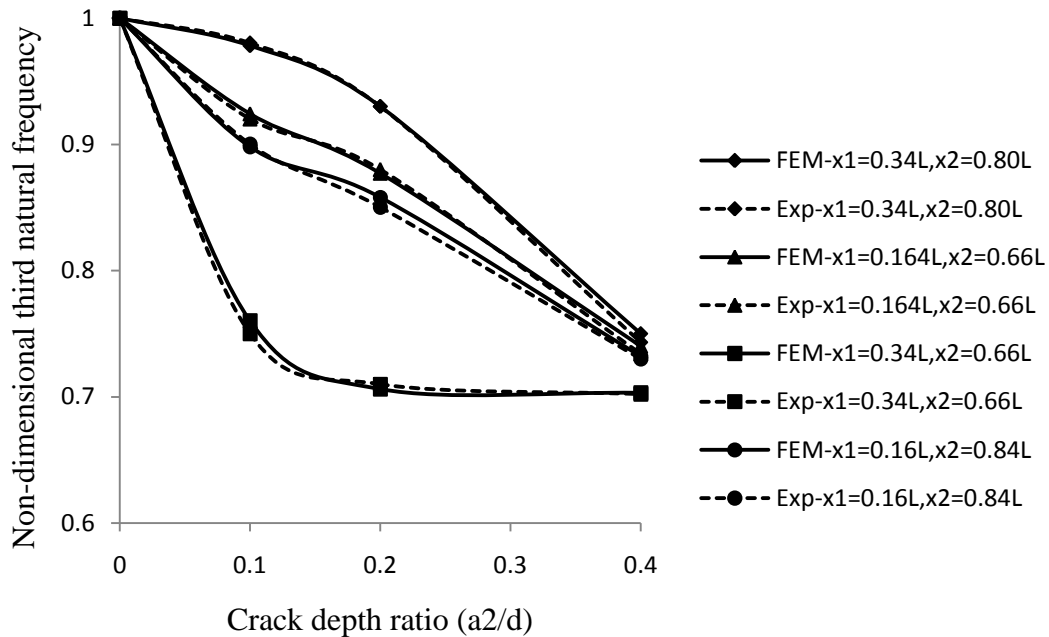

Figure 5.40 Comparison of FEM and experimental results for non-dimensional third natural frequencies of double cracked free-free stepped beam with varying crack depth ratios for different locations of crack.

The plot (Fig 5.40) explains that the non-dimensional third natural frequency reduces more when the cracks are located at ($x_1=0.34L, x_2=0.66L$), 28%, 29.2%, 30% decrease in natural frequency compared to the intact stepped beam for different crack depth ratios is observed.

5.7.2. Cantilever stepped beam

Free vibration analysis for the stepped beam in the presence of two cracks is carried out experimentally and accuracy is validated with the present (FEM) analysis. Different locations of cracks considered for the study is illustrated in Fig 5.41. The plot showing the variation of non-

dimensional first natural frequency for the different positions of cracks considered is given in Fig 5.42.

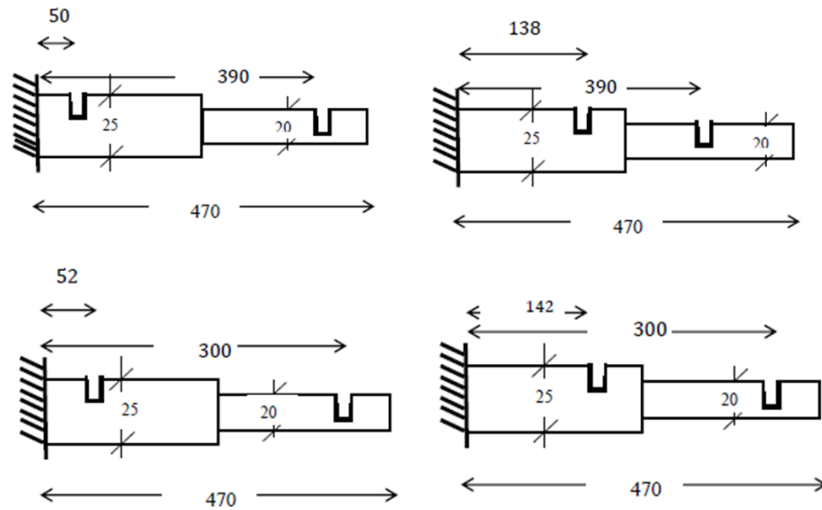

Figure 5.41 Sketch of stepped fixed-free beam with two cracks considered at different locations for the present study.

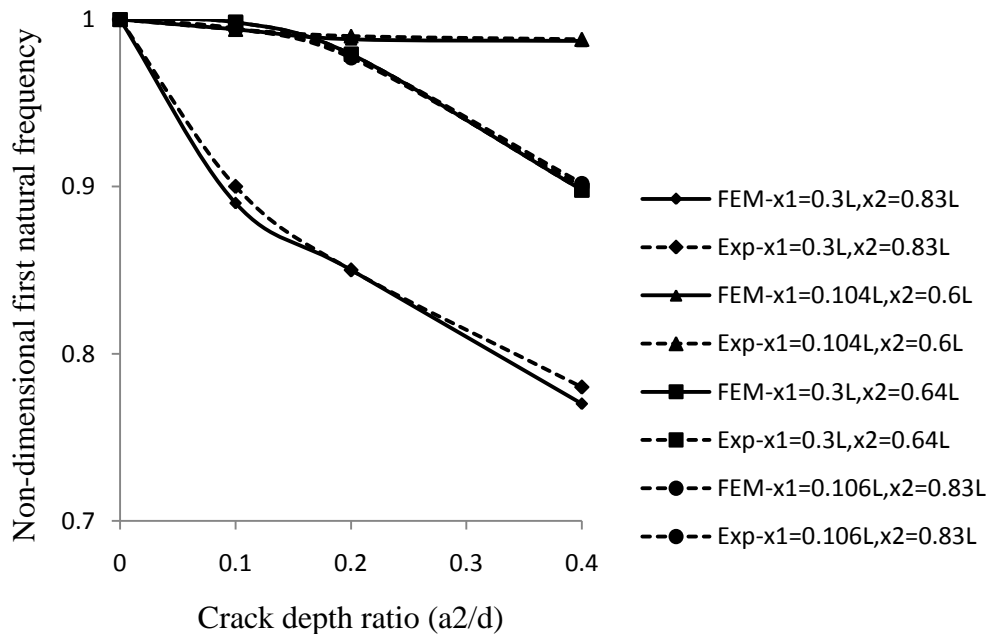

Figure 5.42 Comparison of FEM and experimental results for non-dimensional first natural frequencies of double cracked fixed-free stepped beam with varying crack depth ratios for different locations of crack.

From Fig 5.42, it can be understood that the decrease is high during the location of cracks at step ($x_1=0.30L, x_2=0.64L$; $x_1=0.30L, x_2=0.83L$), 10%,15%,22% reduction is noticed comparing to the intact beam for 0.1,0.2,0.4 crack depth ratios.

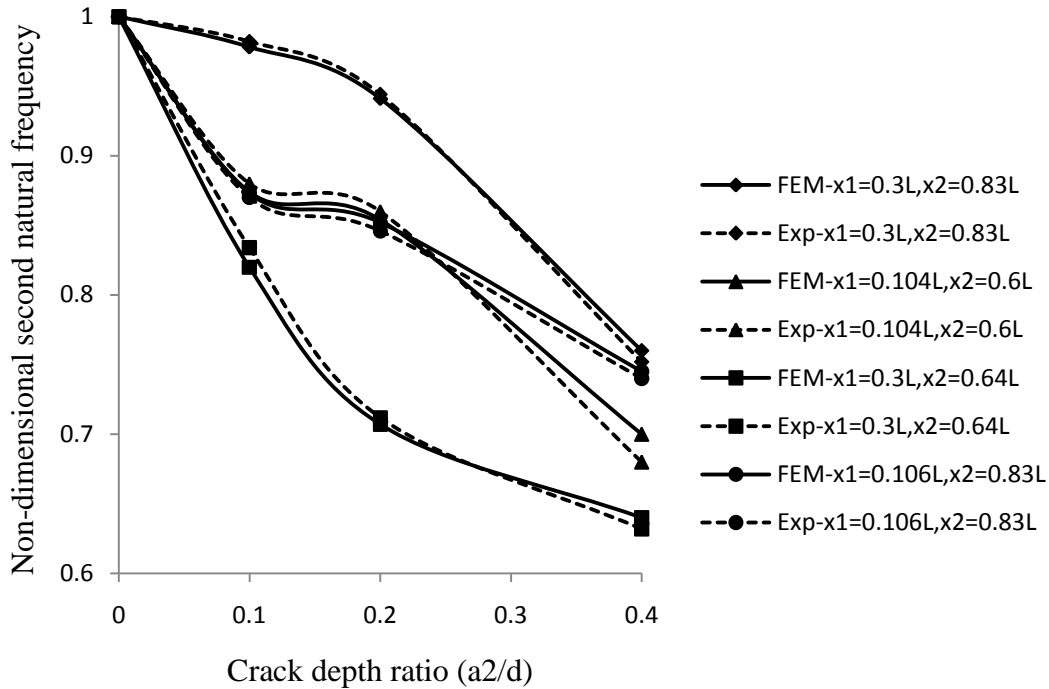

Figure 5.43 Comparison of FEM and experimental results for non-dimensional second natural frequencies of double cracked fixed-free stepped beam with varying crack depth ratios for different locations of crack.

From the Fig 5.43, it is observed that for cracks positioned at $x_1=0.30L, x_2=0.64L$, a decrease of 16.6%, 28.8%, 36.8% when compared to intact stepped beam for different crack depth ratios is noticed. But in the same case if the second crack location moves from $x_2=0.64L$ to $x_2=0.83L$ (free end), meager decrease occurs.

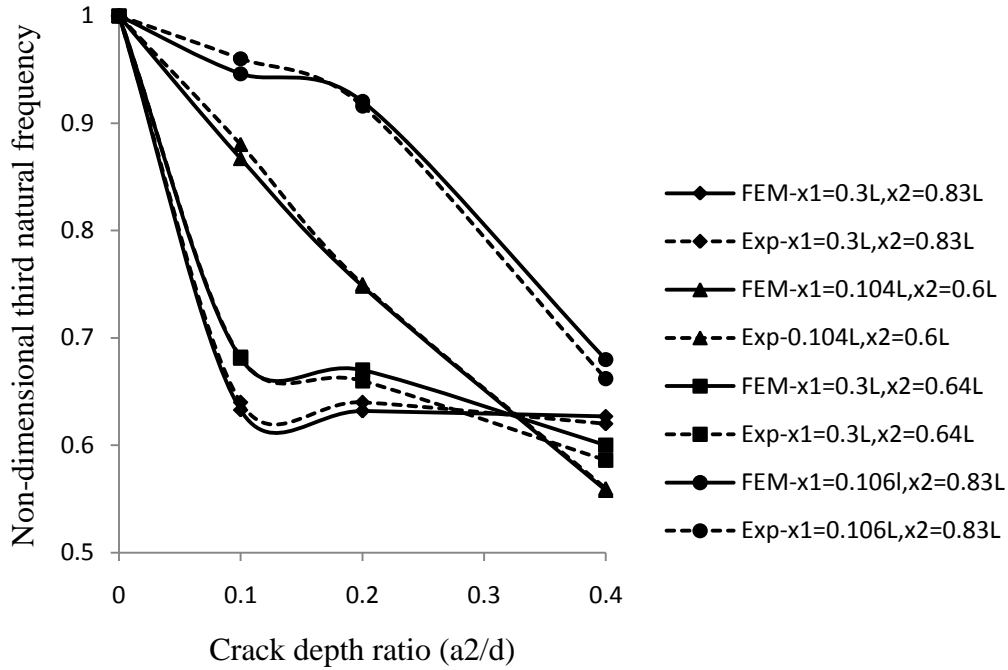

Figure 5.44 Comparison of FEM and experimental results for non-dimensional third natural frequencies of double cracked fixed-free stepped beam with varying crack depth ratios for different locations of crack.

Fig 5.44 represents the variation of non-dimensional third natural frequencies for varying crack depth ratios for different locations of cracks considered for the study. If any of the crack is present near the free end ($x_1=0.106L, x_2=0.83L$; $x_1=0.30L, x_2=0.83L$), the natural frequencies in the third mode is barely affected. Cracks positioned at $x_1=0.104L, x_2=0.6L$ (one near the fixed end and other at the step location) brings maximum decrease of all the locations considered .

5.8. Free vibration of Stepped beam subjected to triple crack

5.8.1. Cantilever stepped beam

Free vibration analysis for the stepped beam in the presence of three cracks is carried out experimentally and accuracy is validated with the present (FEM) analysis. Different locations of cracks considered for the study is illustrated in Fig 5.45. The plot showing the variation of non-dimensional first natural frequency for the different positions of cracks considered is given in Fig

5.46.

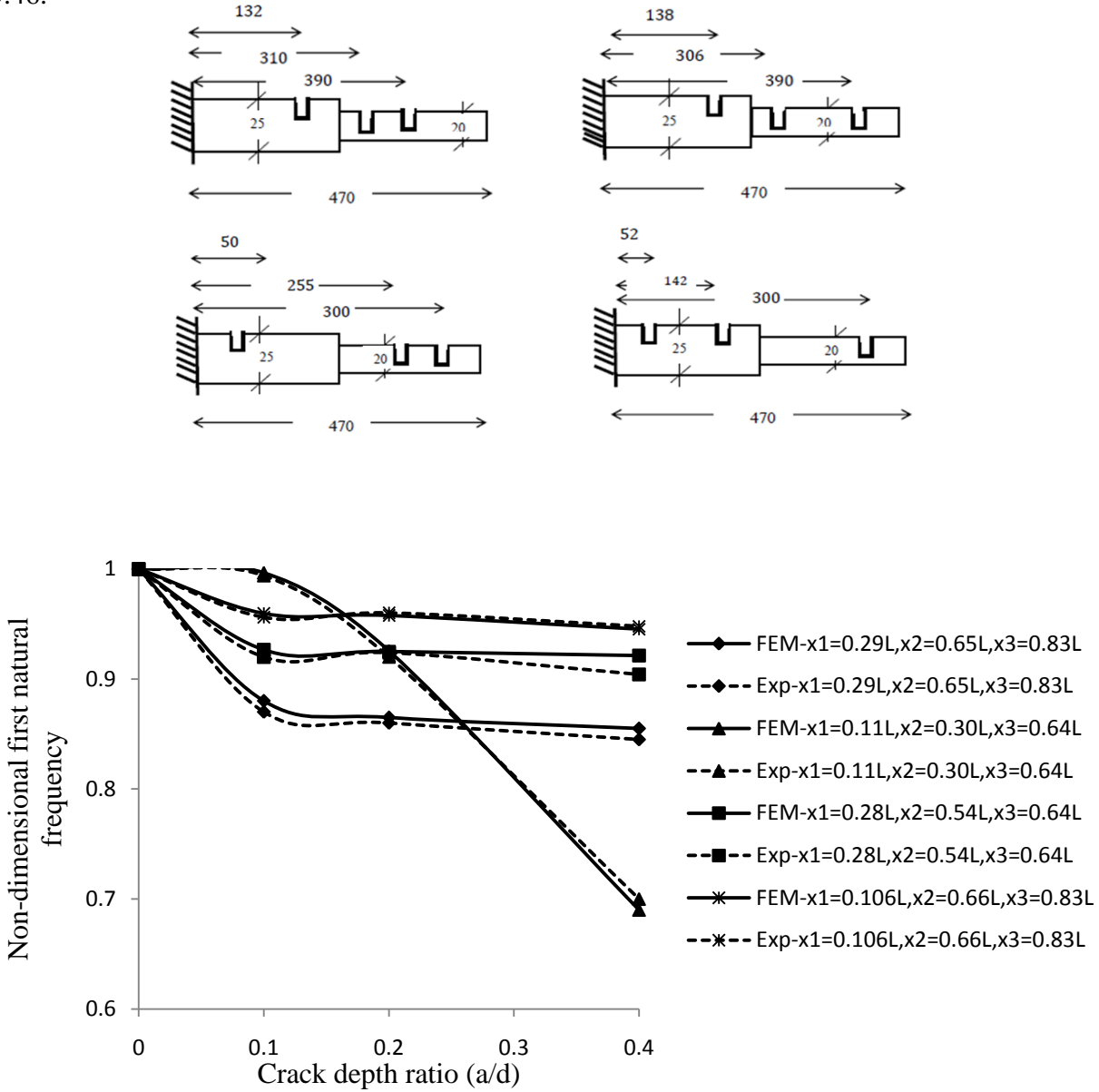

Figure 5.46 Comparison of FEM and experimental results for non-dimensional first natural frequencies of triple cracked fixed-free stepped beam with varying crack depth ratios for different locations of crack.

From the Fig 5.46, it can be understood that greater reduction in non-dimensional first natural frequency is noticed in the vicinity of step part. The cracks located at $x_1=0.11L$, $x_2=0.30L$, $x_3=0.64L$ (one near the fixed end and other two being located near step) bring decrease of 3%, 6.4%, 22.5% when compared to the intact stepped beam for 0.1, 0.2, 0.4 crack

depth ratios respectively. The next high reduction takes place when two cracks are located at step and other crack present near the free end($x_1=0.29L$, $x_2=0.65L$, $x_3=0.83L$). Fig 5.48 draws plot which compares the FEM and experimental results of non-dimensional second natural frequency for different locations of crack as a function of crack depth ratios.

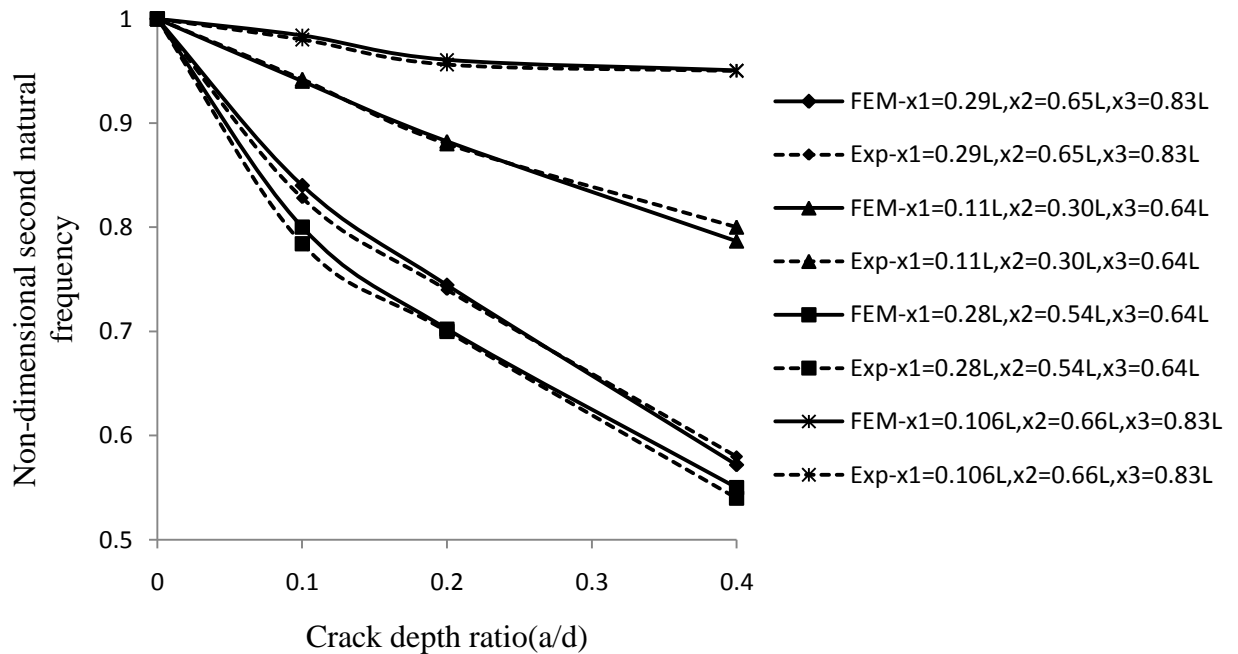

Figure 5.47 Comparison of FEM and experimental results for non-dimensional second natural frequencies of triple cracked fixed-free stepped beam with varying crack depth ratios for different locations of crack.

Fig 5.47 draws the inference that when anyone of the three cracks is located near the fixed end, the non-dimensional second natural frequencies is hardly affected. The cracks located at $x_1=0.28L$, $x_2=0.54L$, $x_3=0.64L$ bring a reduction about 17.56%, 20.75 %, 36.42% when compared to the intact stepped beam for 0.1, 0.2, 0.4 crack depth ratios. Two cracks being located near the step and another away from the fixed end has more affect comparatively. The deviation in the non-dimensional third natural frequencies for different locations of crack with different crack depth ratios is depicted in Fig 5.48

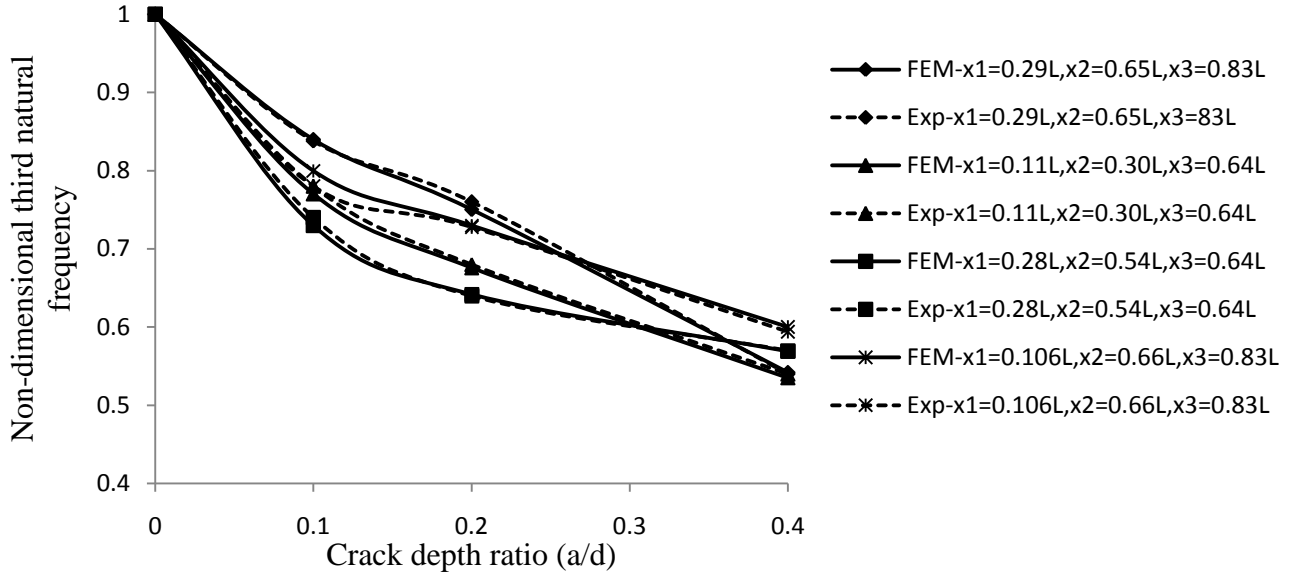

Figure 5.48 Comparison of FEM and experimental results for non-dimensional third natural frequencies of triple cracked fixed-free stepped beam with varying crack depth ratios for different locations of crack.

From Fig 5.48, it can be observed that the cracks located at $x_1=0.11L$, $x_2=0.30L$, $x_3=0.64L$, a decrease of 12.97%, 23.61%, 35.91% is noticed when compared to that of intact stepped beam for 0.1, 0.2, 0.4 crack depth ratios respectively.

5.8.2. Free-free stepped beam

Free vibration analysis for the free-free stepped beam in the presence of three cracks is carried out experimentally and accuracy is validated with the present (FEM) analysis. Different locations of cracks considered for the study is illustrated in Fig 5.49. The plot showing the variation of non-dimensional first natural frequency for the different positions of cracks considered is given in Fig 5.50.

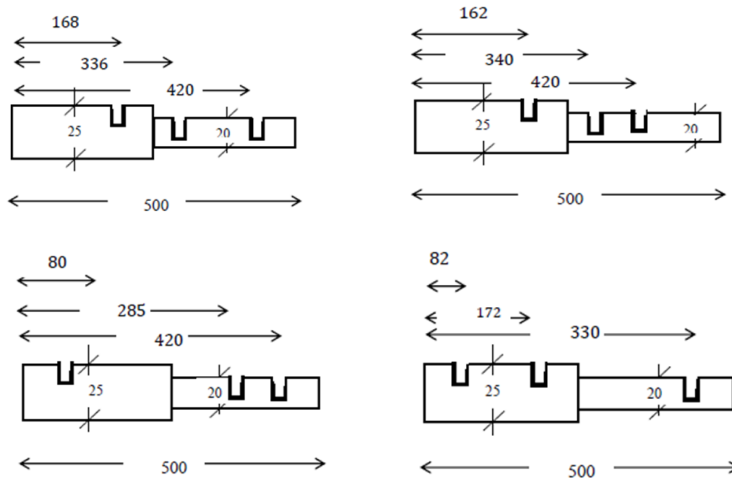

Figure 5.49 Different locations of triple cracks considered for Free-Free Stepped beam (in mm)

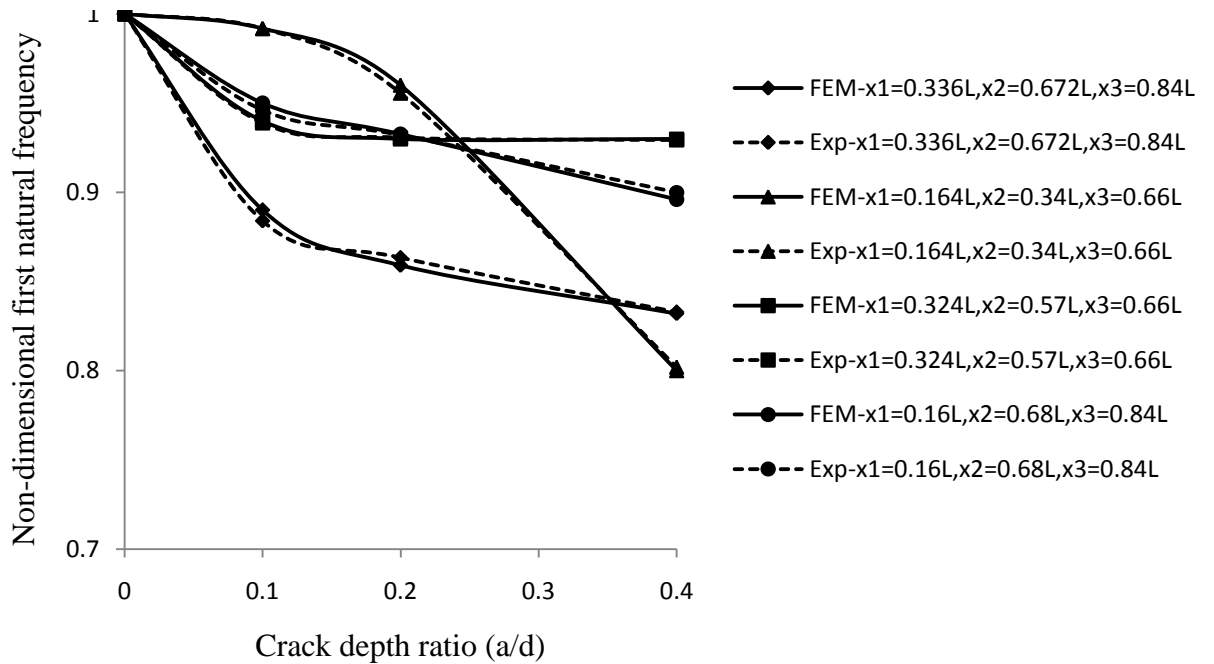

Figure 5.50 Comparison of FEM and experimental results for non-dimensional first natural frequencies of triple cracked free-free stepped beam with varying crack depth ratios for different locations of crack.

Fig 5.50 indicates that for location of cracks at $x_1=0.164L$, $x_2=0.344L$, $x_3=0.66L$, the non-dimensional first natural frequencies decrease to greater extent than compared to the other locations of crack. A reduction of 0.87%, 4.40%, 20.83% compared to intact stepped beam for 0.1, 0.2, 0.4 crack depth ratios is noticed. Concentration of two cracks on the lower step and

another on the higher step of beam does not affect the natural frequencies which is illustrated by the cracks located at $(x_1=0.324L, x_2=0.57L, x_3=0.66L)$ and $(x_1=0.16L, x_2=0.68L, x_3=0.84L)$. The reduction in natural frequencies in the above locations in the first mode is 10.30% range when compared to intact stepped beam for 0.4 crack depth ratios. Fig 5.51 demonstrates the non-dimensional second natural frequency variation for the different positions of cracks considered with varying crack depth ratios.

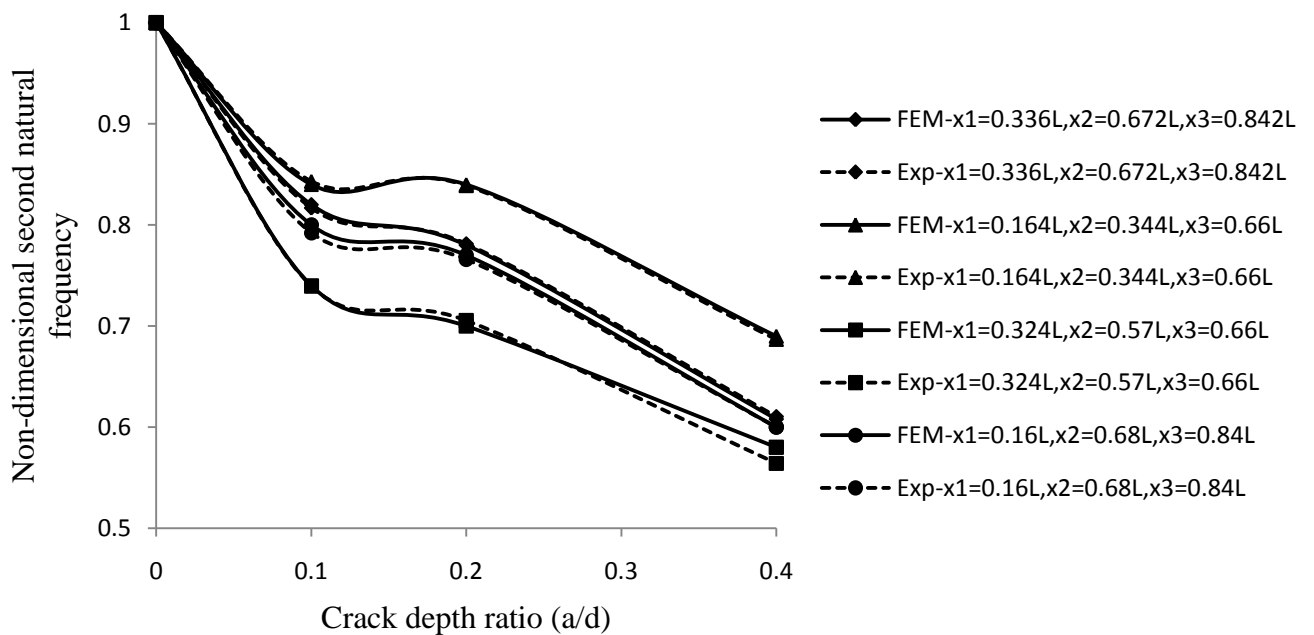

Figure 5.51 Comparison of FEM and experimental results for non-dimensional second natural frequencies of triple cracked free-free stepped beam with varying crack depth ratios for different locations of crack.

The Fig 5.51 illustrates that the non-dimensional second natural frequency is affected more when the cracks are located at $x_1=0.324L$, $x_2=0.57L$, $x_3=0.66L$. A decrease of 26.01%, 29.47%, 43.53% when compared to intact stepped beam for 0.1, 0.2, 0.4 crack depth ratios is present. When cracks are positioned at $x_1=0.164L$, $x_2=0.344L$, $x_3=0.66L$, reduction of 15.63%, 16.09%, 31.27% when compared to intact stepped beam for 0.1, 0.2, 0.4 crack depth ratios is noticed. The crack positions which has more affect on the non-dimensional first natural

frequency barely affects the non-dimensional second natural frequencies. The comparison drawn between the FEM and experimental results for the non-dimensional third natural frequencies for different locations of cracks considered for study with varying crack depth ratios is shown in Fig 5.52.

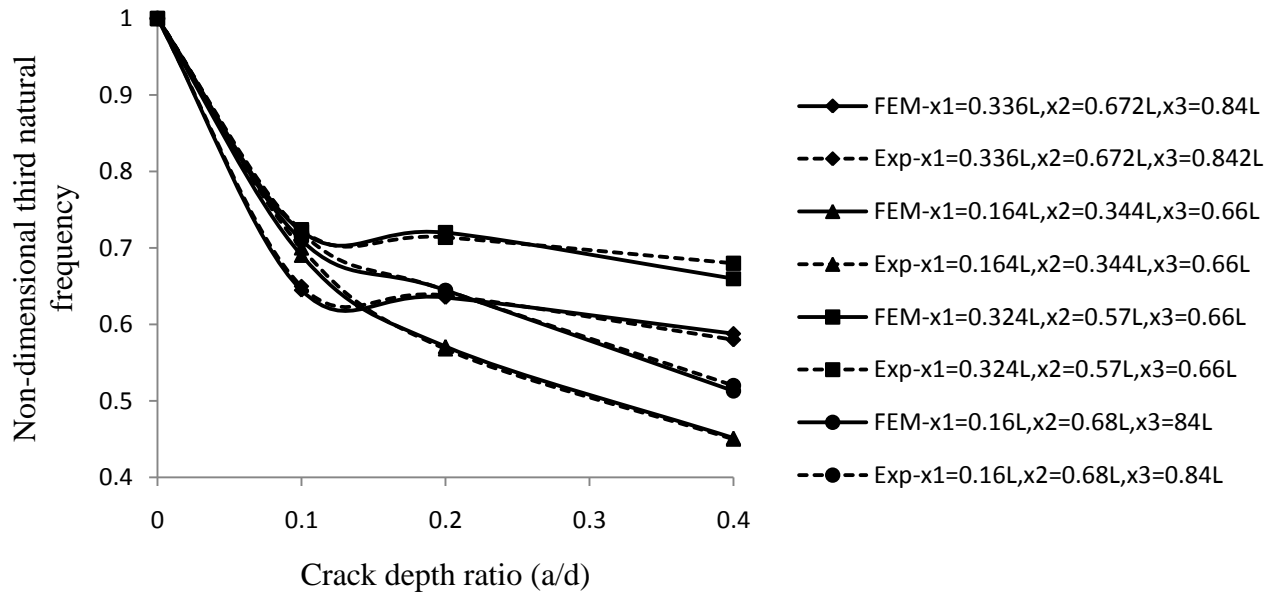

Figure 5.52 Comparison of FEM and experimental results for non-dimensional third natural frequencies of triple cracked free-free stepped beam with varying crack depth ratios for different locations of crack.

It is observed from Fig 5.52 that when two cracks are concentrated on lower step and another crack on the higher step ($x_1=0.164L, x_2=0.344L, x_3=0.66L$) brings reduction about 30.97%, 43%, 55% when compared to the intact stepped beam for 0.1, 0.2, and 0.4 crack depth ratios respectively. Two cracks being concentrated near step and another crack in the lower step ($x_1=0.324L, x_2=0.57L, x_3=0.66L$ and $x_1=0.3336L, x_2=0.672L, x_3=0.84L$) has meager affect on the non-dimensional third natural frequency. A decrease of 25.03%, 28.44%, 34% when compared to the intact stepped beam for 0.1, 0.2, 0.4 crack depth ratios for the above crack location.

Chapter 6

6. CONCLUSIONS

6.1. Conclusions of the work.

Free vibration analysis of uniform and stepped beam subjected with single to multiple cracks is done using Finite Element Method (FEM) in MATLAB environment. An experimental study is carried out to check the accuracy of the numerical results.

- Mathematical formulation for free vibration of uniform and stepped beam with transverse open cracks is presented in detail.
- In all the modes of vibration, as the crack depth ratio increases, the frequency reduction increases irrespective of uniform or stepped beam and boundary condition.
- The natural frequencies of the beam are more influenced by the location of cracks than the depth of crack.
- In the case of uniform cantilever beam, crack positioned near the fixed end affects the natural frequency in first mode more than the crack present in the free end of the beam. This is explained from the reason that position of crack is significant in the region of higher bending moment. Due to the presence of node points, the effect of crack near fixed and free ends of the beam on the third mode non-dimensional natural frequency has very less effect.
- For free-free boundary condition, the crack positioned in the center of beam is more critical for the first and third mode natural frequency. The second mode natural frequency is barely affected when cracks are located at free ends and mid span of beam.

- For cantilever stepped beam, greater drops in the non-dimensional first and third natural frequencies occur when the crack is located in the vicinity of step which could be explained by the reason that the stepped variation in the cross sectional reduces the stiffness of the beam along with the presence of crack near step. If the crack is located near fixed end, the natural frequencies reduction in the second mode is highest.
- For free-free stepped beam, crack present at step part, the first mode natural frequency decreases more than when crack is located at free end. The effect of crack present at step and free ends is barely affected.
- The influence of double crack in the case of fixed-free boundary condition is seen when the concentration of crack near step reduces frequency more than any one of the crack is located near the fixed end. The second natural frequency has meager affect when anyone of the crack is present near free end. The natural frequency in third mode is hardly affected when anyone of crack is near free end.
- The affect of double crack present for free-free stepped beam is studied experimentally and numerically compared for checking the accuracy. It is observed that when any of the two cracks is located in the higher step brings more reduction in the first natural frequency and upon varying the position of crack from free end of the higher step to the step location, reduction level goes on increasing. It is also noted that the third natural frequency is barely affected when any of the crack is present near the free end.
- Three cracks are more critical when they are present in the step part for first natural frequency, the natural frequency in second mode is hardly affected when any of the three cracks is near the fixed end and the third natural frequency is more influenced when two

cracks are present near the step irrespective of presence of third crack in higher or lower step for a cantilever stepped beam.

- For a free-free stepped beam, the concentration of three cracks (two on the higher step and other on the lower step) reduces the natural frequency in first and third mode. The presence of crack in the vicinity of step and concentration of atleast one crack in higher step has more influence. It is seen that the second natural frequency is barely affected for the crack position where first natural frequency is affected (i.e. more affect is seen when cracks are located on lower step).

6.2. Scope for the future work.

There is a lot of scope to extend this project work in the directions listed underneath

1. The present work focus is based on Euler-Bernoulli beam theory; it can be further carried out for Timoshenko beam considering the hygrothermal effects.
2. The study has dealt with square area of cross section; it can be extended to study the effect of multiple cracks in stepped beam for circular cross section.
3. Buckling analysis of stepped beam can be carried out numerically and experimentally.
4. The study can be extended for the composite materials to study the variations in the composite beams in the presence of multiple cracks.

References

- Ameneh M., Amin G., and Hamid R. M. (2012), “Multiple-crack damage detection in multi-step beams by a novel local flexibility-based damage index”, *Journal of sound and vibration*, 332, 294-305.
- Celalettin Karaagac , Hasan Öztürk , Mustafa Sabuncu (2009), “Free vibration and lateral buckling of a cantilever slender beam with an edge crack: Experimental and numerical studies”, *Journal of Sound and Vibration*, 326, 235–250.
- Chen et.al (2005) “Detection of crack location and size in structures using wavelet finite element methods”, *Journal of Sound and Vibration*, 285, 767–782.
- Guohui D., and Xinwei W. (2013), “Free vibration analysis of multiple-stepped beams by the discrete singular convolution”, *Applied Mathematics and Computation*, 219, 11096-11109.
- H M., and Shen H. (1994), “Free vibrations of beams with a single-edge crack”, *Journal of sound and vibration*, 170(2), 237-259.
- Han-Ik Yoon, In-Soo Son, Sung-Jin Ahn (2007),” Free Vibration Analysis of Euler-Bernoulli Beam with Double Cracks”, *Journal of Mechanical Science and Technology*, 21, 476~485.
- Jaworski J. W., and Dowell D. H. (2008), “Free vibration of a cantilevered beam with multiple steps”, *Journal of Sound and Vibration*, 312, 713–725.
- Khiem N.T., Lien T.V. (2004), “Multi-crack detection for beam by the natural frequencies”, *Journal of Sound and Vibration* ,273 , 175–184.
- Kisa et.al(2000), “Free vibration analysis of multiple open-edge cracked beams by component mode synthesis”. *Structural Engineering Mechanics* , 10 (1), 81 92.

Koplow M. A., Bhattacharyya A., and Mann B. P. (2006), “Closed form solutions for the dynamic response of Euler-Bernoulli beams with step changes in cross-section”, *Journal of sound and vibration*, 295, 214-225.

Lee (2009), “Identification of multiple cracks in a beam using natural frequencies”, *Journal of Sound and Vibration*, 320, 482–490.

Mao. (2011), “Free vibration analysis of multiple-stepped beams by using Adomain decomposition method”, 54, 756–764.

Mostafa A. (2012), “A transfer matrix method for free vibration analysis and crack identification of stepped beams with multiple edge cracks and different boundary conditions”, *International journal of Mechanical sciences*, 57, 19-33.

Owolabi G.M., Swamidas A.S.J., Seshadri.R (2003),” Crack detection in beams using changes in frequencies and amplitudes of frequency response functions”, *Journal of Sound and Vibration*, 265 , 1–22.

Pandey A. K., Biswas M., and Samman M. (1991), “Damage detection from changes in curvature mode shapes”, *Journal of sound and vibration*, 145(2), 321-332.

Patil D.P. and S.K. Maiti (2005),” Experimental verification of a method of detection of multiple cracks in beams based on frequency measurements”, *Journal of Sound and Vibration*, 281 ,439–451.

Qian GL, Gu SN, Jiang JS. (1990), “The Dynamic Behavior And Crack Detection Of A Beam With A Crack”, *Journal of Sound and Vibration* , M(2), 233-243

Rizos P. S., Aspragathos T., and Dimarogonas, A. D. (1989), “Identification of crack location and magnitude in a cantilever beam from the vibration modes”, *Journal of Sound and Vibration*, 138(3), 381-388.

- Ruotolo, R., Surace, C., Mares, C., (1996), "Theoretical and Experimental Study of the Dynamic Behavior of a Double-Cracked Beam," *Proceedings of the 14th International*
- Saavedra P. N., and Cuitino L. A. (2001), "Crack detection and vibration behavior of cracked beams", *Computers and structures*, 79, 1451-1459.
- Shen M. H., and Pierre C. (1986), "Modes of free vibrations of cracked beams", 1-46.
- Shifrin E. I., and Rutolo R. (1999), "Natural frequencies of a beam with an arbitrary number of cracks", *Journal of Sound and Vibration*, 222(3), 409-423.
- Subramaniam G., and Balasubramanian T. S. (1987), "Beneficial effects of steps on the free vibration characteristics of beams", *Journal of sound and vibration*, 118(3), 555-560.
- Xinwei W., and Yongliang W. (2013), "Free vibration analysis of multiple-stepped beams." *Applied Mathematics and Computation*, 219, 5802–5810.
- Zheng D. Y., and Kessissoglou N. J. K. (2004), "Free Vibrational Analysis of Cracked beam by finite element method", *Journal of Sound and Vibration*, 273, 457-475.