

# Design of an Automatic Trolley

*A thesis submitted in partial fulfillment of the  
Requirements for the degree of*

**Bachelor of Technology**

In

**Industrial Design**

By

**Ansh Mahil (111ID0573)**

**Dheerendra Singh Rajput (111ID0473)**



Department of Industrial Design  
National Institute of Technology, Rourkela  
Rourkela, Odisha – 769008

# Declaration

---

We Hereby Declare That This Thesis Is Our Own Work And Effort. Throughout This Documentation Wherever Contributions Of Others Are Involved, Every Endeavour Was Made To Acknowledge This Clearly With Due Reference To Literature. This Work Is Being Submitted For Meeting The Partial Fulfilment For The Degree Of Bachelor Of Technology In Industrial Design At National Institute Of Technology, Rourkela For The Academic Session 2011 – 2015.

**Ansh Mahil (111ID0573)**

**Dheerendra Singh Rajput (111ID0473)**



NATIONAL INSTITUTE OF TECHNOLOGY

ROURKELA 769008, INDIA

## Certificate of Approval

This is to certify that the thesis entitled “**DESIGN OF AN AUTOMATIC TROLLEY**” submitted to the National Institute of Technology, Rourkela by **ANSH MAHIL, Roll No. 111ID0573** and **DHEERENDRA SINGH RAJPUT, Roll No. 111ID0473** for the award of the Degree of Bachelor of Technology in Industrial Design Engineering is a record of bona fide research work carried out by them under my supervision and guidance. The results presented in this thesis has not been, to the best of my knowledge, submitted to any other University or Institute for the award of any degree or diploma. The thesis, in my opinion, has reached the standards fulfilling the requirement for the award of the degree of Bachelor of technology in accordance with regulations of the Institute.

**Prof . B.B.V.L.Deepak**

Assistant Professor

Department of Industrial Design

National Institute of Technology, Rourkela

Date:

# Acknowledgement

---

We have taken efforts in this project. However, it would not have been possible without the kind support and help of many individuals and the department. We would like to extend our sincere thanks to all of them.

We would like to express our gratitude and special thanks to our project guide Prof. B.B.V.L. Deepak, Assistant Professor, Department of Industrial Design, NIT Rourkela, for all the cooperation and time. We would also like to thank our head of the department Prof. Bibhuti Bhusan Biswal for giving us such attention and time.

Our especial thanks to all the students as well as Professors for giving their whole hearted cooperation in participating in the survey conducted by us.

Ansh Mahil (111ID0573)

Dheerendra Singh Rajput (111ID0473)

## **ABSTRACT**

In today's life style, daily tonnes of goods and products are produced and they are carried or transported from one place to another. The journey of transportation of the products can be from a mile to 1000's of miles. For transporting the goods or products, some source of mobile things like trucks, trolley, carriage, ship, train, aeroplane etc , are required to carry those items. Some goods weigh's some kilo's to some of the goods to tonnes which are transported as per the requirement of the user. Some of the transportation aid's are automatic like trucks, train, ship etc, while some of the transportation aid's are manual based like trolleys, carriage, rickshaws etc, which require the manual help to pull or push them over the journey of the transportation. As per today's life style time is money in some words, so time of transportation is directly proportional to the cost of products and profit gained from. Thus to achieve short time period transportation journey the carrier should be sufficiently able to provide as much as low time period, thus it should be more advance and more comfortable to the user.

In present work, the focus is given on the time period, comfort, advancement, low cost, and mainly manual work is aimed to be reduced as much as possible. The model here made aims on providing automatic motion to the user with the help of some external sources so that the time of transportation can be reduced so as to increase the efficiency of carrier and to increase the profit. An attempt is made here in this work on enlargement of the space of the platform so that more and more goods can be transported at one time. But the enlargement of platform made here is portable i.e. can be increased or decreased as per the requirement of the user and quantity of the goods. Further emphasis is given on the weight of the trolley so that the motion can be executed with ease and in less time period user can perform the work. The design is validated by developing digital mock up generated in CATIA V5 and are assembled to form a final product. Physical prototype including the structure and functionality is developed using wood and ABS material.

Keywords : Trolley, Transportation, platform.

# CONTENTS

<b>List Of Figures</b>	i
<b>List Of Tables</b>	ii
<b>Nomenclature</b>	iii
<b>1. Introduction</b>	1
1.1 Problem Statement	1
1.2 Objective of the work	1
<b>2. Literature Review</b>	2
<b>3. Methodology</b>	4
3.1 Basic Concepts Of Trolley	4
3.2 Existing Models	4
3.2.1 <i>Traditional wooden carriage</i>	4
3.2.2 <i>Metal trolley</i>	4
3.2.3 <i>Two wheeled trolley</i>	5
3.2.4 <i>Cycle rickshaw trolley</i>	6
3.3 Factors to Consider while Designing	6
3.4 Comparison of Existing Trolleys	7
3.5 Features Of Automatic Trolley	8
3.6 Advantages Of Automatic Trolley	8
3.7 Area Of Uses	8
3.8 Steering Mechanism	8
3.9 Front and Back motion	9
3.10 Power Source	9
3.11 Speed Control	9
3.12 Platform Enlargement	10
3.13 Material Selection	10
3.13.1 <i>Material for platform</i>	10
3.13.2 <i>Pneumatic tyre wheels</i>	11
<b>4. Detail Design</b>	12
4.1 Calculation of Drive Wheel Torque and Motor Selection Criteria	12
4.2 Calculation of Torque in Loaded Condition	15
4.3 Motor Selection Criteria	18
4.4 Static Structural Analysis of Platform During Loading Conditions	18
4.5 Calculation of Torque Required for Screw Jack	21
4.6 Grip Dimensions	22
4.7 Handle Holding Height	22
4.8 Concept Selection	23
4.9 CAD Model	23
<b>5. Results And Discussions</b>	24
<b>6. Conclusions</b>	25
<b>References</b>	26

## LIST OF FIGURES

Fig.1 Traditional wooden carriage	4
Fig.2 Metal trolley	5
Fig.3 Two wheeled trolley	5
Fig.4 Cycle rickshaw trolley	6
Fig.5 Steering mechanism	9
Fig.6 Steering mechanism top view	9
Fig.7 Platform enlarging mechanism	10
Fig.8 Design of selected motor	18
Fig.9 Deformation of Platform in ANSYS	19
Fig.10 Deformation of Platform in ANSYS	19
Fig.11 Deformation of Platform in ANSYS	20
Fig.12 Deformation of Platform in ANSYS	20
Fig.13 Deformation of Platform in ANSYS	21
Fig.14 Deformation of Platform in ANSYS	21
Fig.15 Screw Jack Mechanism	22
Fig.16 CAD model of screw jack	22
Fig.17 Percentile value and normal distribution graph	23
Fig.18 Concept selection	23
Fig.19 CAD model generated in CATIA V5	23

## LIST OF TABLES

Table 1 Comparison Of Existing Trolleys.	7
Table 2 Tabular Data of Drive wheel torque and load.	17



## NOMENCLATURE

GVW	= Gross Vehicle Weight
$R_w$	= Radius of wheel/tire
$V_{max}$	= Top speed
$\alpha$	= Inclination angle
$W_w$	= Weight on each wheel drive
TTE	= Total Tractive Effort
RR	= Rolling Resistance
GR	= Grade Resistance
FA	= Acceleration Force
$t_a$	= Time to attain top speed
MTT	= Maximum Tractive Torque
$T_w$	= Drive Wheel Torque
$T_d$	= Drive Torque for Screw Jack
F	= Load to Lift
P	= Pitch of Screw
$M_L$	= Idling Torque
$\eta$	= Efficiency

## **1. INTRODUCTION**

In the areas of transportation various carrying vehicles are available, but most of them have a problem of manual pushing and pulling, difficult steering. So these types of problems led to the development of the automatic trolley capable of reducing manual effort during driving and steering. Electrically powered trolley also reduces time to reach the destination and increases profit . The problem of carrying heavy loads in a wheel cart or similar vehicles provide a vision to develop a trolley which can solve these problems. The new era of world demands an interactive and ergonomically suitable product like those product which are affordable but should reduce human efforts , best suited to environment , easy to carry , and do not require maintenance .

### **1. 1 Problem Statement**

To fulfil the needs of the transportation some carrying vehicles are required. As per today's demands of the customer those carrying vehicles should be able to carry enough amount of payload and in much less time. So our work aims on designing such vehicle which can carry goods in less time and require less efforts from worker.

### **1. 2 Objective of the Work**

The main objectives of the work are: Minimizing the time period of carrying the goods as compared to human powered trolley. Modifying the old trolleys by making it automatic. Reducing the problem of slipping and toppling. Attaining variable speed as per requirement. Platform Enlargement. To develop a product fulfilling these objectives , it is necessary to evaluate all results in CATIA V5 and ANSYS .

## 2. LITERATURE REVIEW

Malek et al [1] research the various mathematical formulation of the human hand reach in work place with consideration of ergonomic design. We know Ergonomic design has depended upon trial, error and vastly on empirical data, experience and rules of thumb are used. So it is possible to establish an ergonomic design that satisfies the given constraints. The purpose this paper is to minimise the stress in body. In trolley when person pull or push, loading or unloading so due to heavy load persons may go through limb pain and twisting of wrist. By defining the new point for orientation of limb's workplace with respect to aim point. We can see the limb's workspace window in 3D and to mathematically explore operations that can be conducted on any workspace. Schmucker et al [2] have done the study on accident occur in motorised rickshaws in urban area india. Due to its fast speed and design of rickshaws so many injury happens. In their study they go to hospital and survey the accidental patients in which 139 out of 781 were injured by motorised rickshaws or crashing involved in rickshaws. These data on crashes and injuries sustained in crashes involving motorised rickshaws can assist with planning to deal with redesign of motorised rickshaws and other vehicle which are similar to that one. Improved understanding of the risk characteristics of motorised rickshaws can be used for develop safer carry motorised trolley for big cities whose front look same as rickshaws having lower velocity. [end mail] Anthropometric parameters required to be considered for the design of seat ergonomically, a book on Indian anthropometric dimensions by Prof. D.K.Chakraborty is referred. Necessary measurements and data have been collected from Indian Anthropometric Design. Paolo Gallina [3] we know screw jack mechanisms will vibrate in some condition it may be due to motion, downward motion, and wrong design of threading. So for calculating the vibration of various thread type screw jack he give some formula for calculating the vibration and by these formula we can also calculate the torque, and mean radius of jack. In his study 2 DOF model is taken which is suitable for lifting platform of trolley. The study take into both the squared and triangle- threaded screw jack. For the trolley among squared threaded screw jack is better than the triangular screw because we need more external load on the upper head. After designing the layout of trolley first thing will be done is to calculation of power required for driven the trolley. So we have study the textbook of machine design from where got formulas of torque in load and unload condition. And also take information from "MAE Design and Manufacturing Laboratory". When selecting drive wheel motors for mobile vehicles, a number of factors must be taken into account to determine the maximum torque required. Some of them are gross vehicle weight (GVW), weight on each drive wheel, radius of wheel /tire, desired top speed, maximum incline angle. By these formula we have calculate the torque of many motor how much load it can carry. From studying to choose motors capable of producing enough torque to propel the example vehicle, it is necessary to determine the total tractive effort (TTE) requirement for the vehicle. Li et al [5] as one of the significant parameters to characterize the motor performance, motor efficiency changes under different speed and load conditions. Although there are many methods to measure the partial load motor efficiency under the full speed condition, few of them are available to estimate the efficiency under partial speed conditions. In this paper, a new and original concept of "load ratio" is brought forward to describe the motor performances. A simple method is proposed to estimate the motor efficiency under variable speeds operations and partial load conditions

using load ratio, speed ratio, rated motor power and rated motor efficiency. To validate the accuracy of this method, the partial loads full speed operation data from the MotorMaster+ database and the published data under the variable speed conditions from other researcher's tests are used for demonstration. The results indicate that the relative errors using the proposed method at full speed are within  $\pm 5\%$ . Under variable speed conditions, the relative error is within 10% when the speed ratio is above 0.5. Intrusive measurements are not necessary. For an in-service motor installed with a VFD, the key parameters of motor speed and power can be directly obtained from VFD through analog or digital communication. Only the rated motor power and efficiency are required from motor nameplate.

### 3. METHODOLOGY

#### 3.1. Basic Concepts Of Trolley

A trolley is moveable platform which is used for carrying the goods so a trolley must have certain basic features for the transportation purpose like sufficient space for carrying goods, light weighted, low cost, steering mechanism, front and back motion etc. The trolley should have a good enough mechanism for pulling and pushing easily.

#### 3.2. Existing Models

There are various existing models present in the market but they require manual power to pull or push them. This creates a problem for the workers to carry heavy payload or small payload for a long distance. Some models made of metals are heavy to them also creates a problem for individual worker, so these types of model requires 2 or more workers to move them. Some models are not capable of carrying large amount of goods due to insufficient space or area of the platform.

##### 3.2.1 Traditional wooden carriage

This type of model was fully wooden made and it requires Workers had to provide manual work for pulling and pushing. So due to this workers feel tired over a short interval of time.

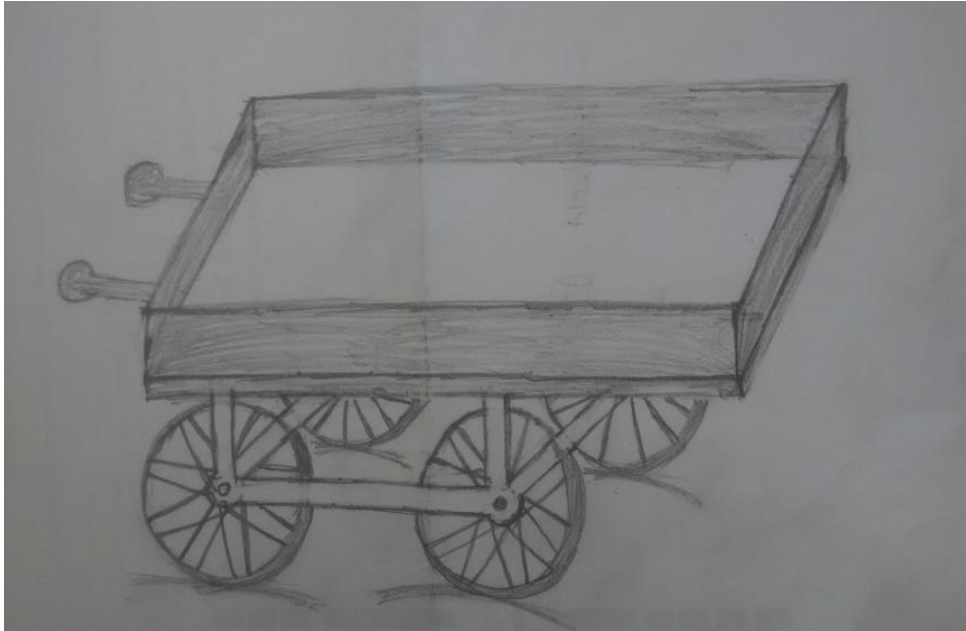

Fig.1 Traditional wooden carriage

Disadvantage

- 1) Not stable at inclined planes.
- 2) Cannot carry large load and 2 to 3 workers are required for moving it.
- 3) Due to heavy payload its wheels get twisted and spokes bent.

##### 3.2.2 Metal trolley

Fully made up metal and consists of a liver which helps in steering it right or left.

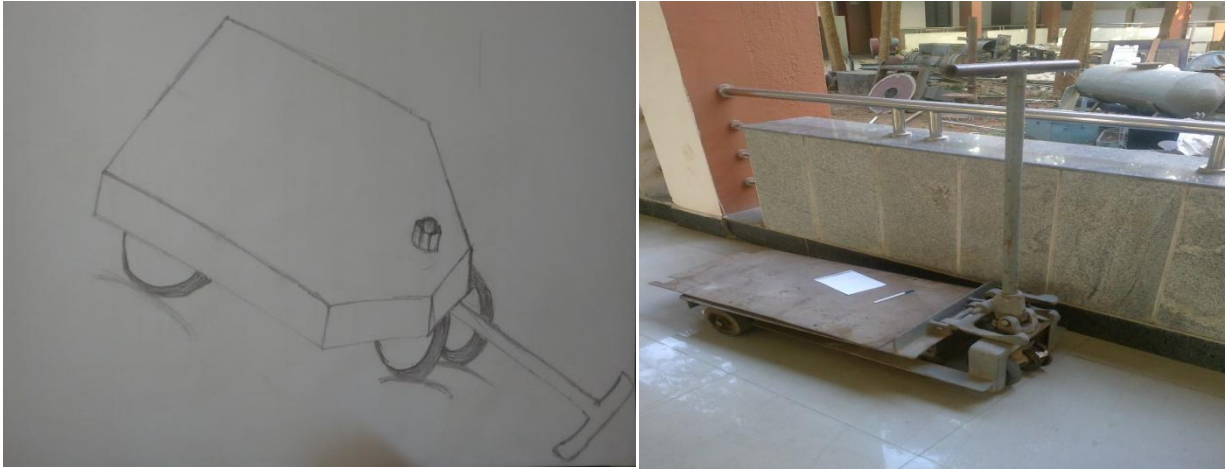

Fig.2 Metal trolley

#### Disadvantage

- 1) More man power are required due to its small wheels and heavy weight.
- 2) Cannot move in rough surface.
- 3) Payload are moved down in inclined surface.

#### 3.2.3 Two wheeler trolley

This type of model have only 2 wheels and a deeper platform space for keeping the goods.

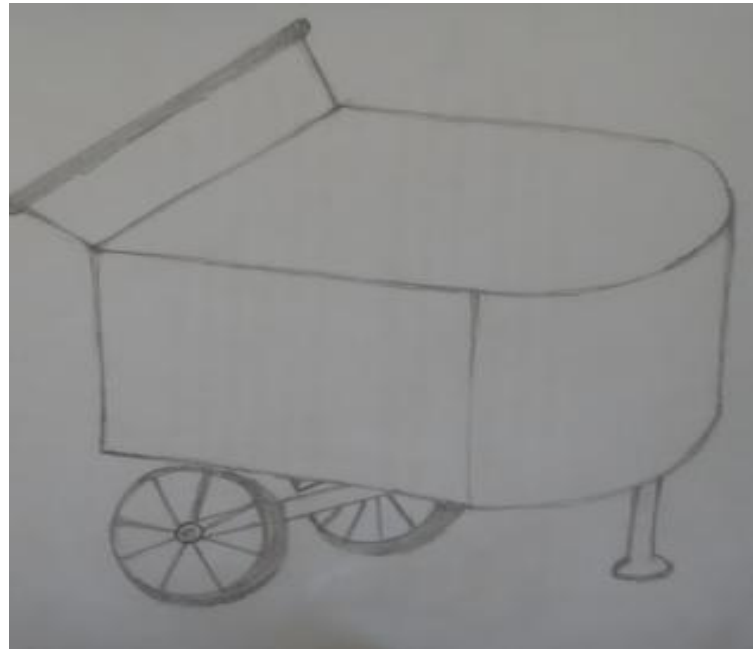

Fig.3 Two wheeled trolley

#### Disadvantage

- 1) Unable to carry large load and cannot move in bumpy road
- 2) Platform space is very small to carry large payload.

#### 3.2.4 Cycle rickshaw trolley

This type of model was fully made on the concept of cycle. This model was useful for long distance transportation purpose and it also enough space to carry more amount of goods as compared to other models.



Fig.4 Cycle rickshaw trolley

#### Disadvantage

- 1) Very unstable in zigzag movement and cannot take much payload.
- 2) Some accident may occur due to unbalancing.
- 3) Requires caring for safety purpose.

#### **3.3 Factors to Consider while Designing**

1. Age
  - a) 18-25
  - b) 25-35
  - c) 35-50
  - d) Above 50
2. Type of work to be performed
  - a) Construction
  - b) Transportation
  - c) Other
3. Load needed to carry
  - a) 100-200kg
  - b) 200-350kg
  - c) 350-500kg
  - d) Above 500kg
4. Type of difficulties faced in driving the trolley
  - a) Payload
  - b) Steering
  - c) Slipping
  - d) Toppling
  - e) Braking

f) Manpower

5. Type of difficulties faced during lifting of objects

- a) Back pain
- b) Height of platform
- c) Tearing of cloth
- d) Getting injured

6. Height of platform

- a) up to 50cm
- b) 50cm to 100cm
- c) above 100cm

7. Area of platform

- a) <1 sq m
- b) <2 sq m
- c) <3 sq m

8. Type of wheels to be used

- a) Metal Wheels
- b) Rubber tyre wheels
- c) Pneumatic tyre wheels

### 3.4 Comparison Of Existing Trolleys

**Table 1 Comparison Of Existing Trolleys**

	Wooden carriage	Metal trolley	Two wheeled trolley	Cycle rickshaw trolley	Railway platform trolley
1. Payload	<300kg	<200kg	<100kg	<400kg	<400kg
2. Speed	<3km/h	Very low	Low	<10km/h	<4km/h
3. Steering	Very Difficult	Easy	Difficult	Easy	Easy
4. Material of platform	Wood	Metal	Metal	Wood or metal	Metal
5. Height of platform	100-120cm	<30cm	<60cm	125-150cm	50-100cm
6. Wheels	Rubber Tyre wheels	Metal wheels	Metal wheels	Rubber Tyre wheels	Metal Wheels
7. Driving	Manual push and pull	Manual pull	Manual push	Paddle driven	Manual push and pull
8. Controlling	Difficult	Easy	Easy	Medium	Difficult

### 3.5 Features Of Automatic Trolley

- 1) Large and sufficient space in platform to carry large amount of goods or materials as compared to existed models.
- 2) Electric based trolley i.e. have motors interfaced with wheels for movement.
- 3) Single motor with single wheel.
- 4) Power source will be battery based.



- 5) Battery can be recharged on demand.
- 6) Front wheels are attached with a lever.
- 7) Lever is used for changing the directions or for steering the trolley.
- 8) Variable speed can be achieved by changing voltage in motor with the help of a voltage regulator.

### 3.6 Advantages Of Automatic Trolley

- 1) Do not require manual power. It runs automatically by electricity.
- 2) Rechargeable battery source.
- 3) Variable speed can be attained.
- 4) Time period required for any journey of transportation is less as compared to the existing models .
- 5) Workers do not feel tired as they do not have to pull or push it.
- 6) Platform area can be enlarged on demand of the user i.e. platform is portable and can be expanded.
- 7) As compared to existed models, direction can be easily changed i.e. steering is easy.
- 8) Safety to payloads by providing walls on the sides.

### 3.7 Area Of Uses

- 1) Local society
- 2) Hospitals
- 3) Hotels
- 4) Malls
- 5) Small work area like construction.
- 6) Can be used by individuals for own purpose.

### 3.8 Steering Mechanism

The steering mechanism of the trolley is like that of the cycle only. The front wheels are connected with the axle which is connected with a rotating shaft. The shaft will be rotated manually with constrained motion which will further rotate the front axle which provide rotation to the wheels. The motion of steering will be constrained to the right and left directions to some extent only. The rear wheels will follow the front wheels only while movement of the trolley.

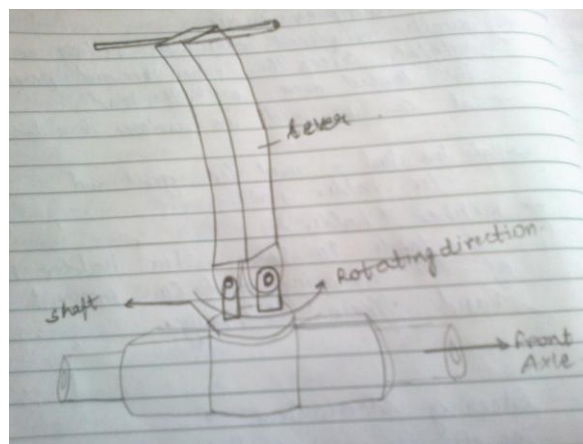

Fig.5 Steering mechanism

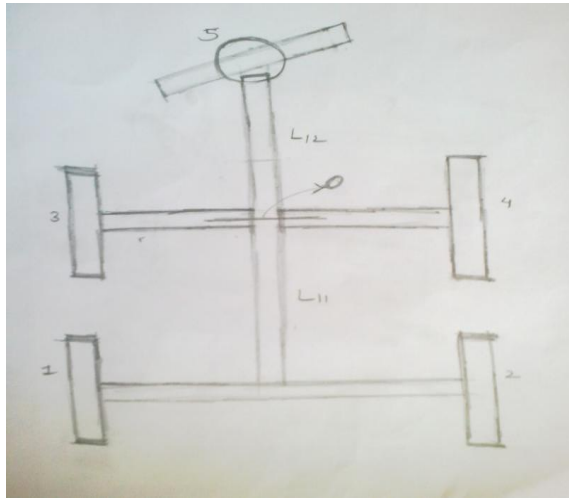

Fig.6 Steering mechanism top view

### 3.9 Front and Back motion

The front and back motion of the trolley will be executed by motors only. The clockwise and anticlockwise rotation of the motors will help the trolley to move in the front and back directions. The change of polarity of current will help in change of spin of rotation of motors. The polarity of current will be changed with the help of a DPDT switch.

### 3.10 Power Source

The power source for the motors will be from a rechargeable battery. The battery will be sufficient enough in power rating to support 4 motors to run the wheels. Each motor will be connected to individual wheel. Battery can be recharged from 220 volt supply line.

### 3.11 Speed Control

The speed control of trolley will be the major issue at the work area as at different time different speed will be required. So voltage regulator will help in controlling the speed by changing voltage at the motors which will control motors rpm. A voltage regulator will help the user to attain as much as speed required by him. At some inclination the variation of speed will be helpful for the trolley to cover the height with ease as compared to existed models of trolleys which are pushed manually on inclination with much difficulty.

### 3.12 Platform Enlargement

The Platform is so designed that it's can be increased and decreased as per requirement or need of the user. Two plates are overlapped to each other and those plates can be opened and closed.

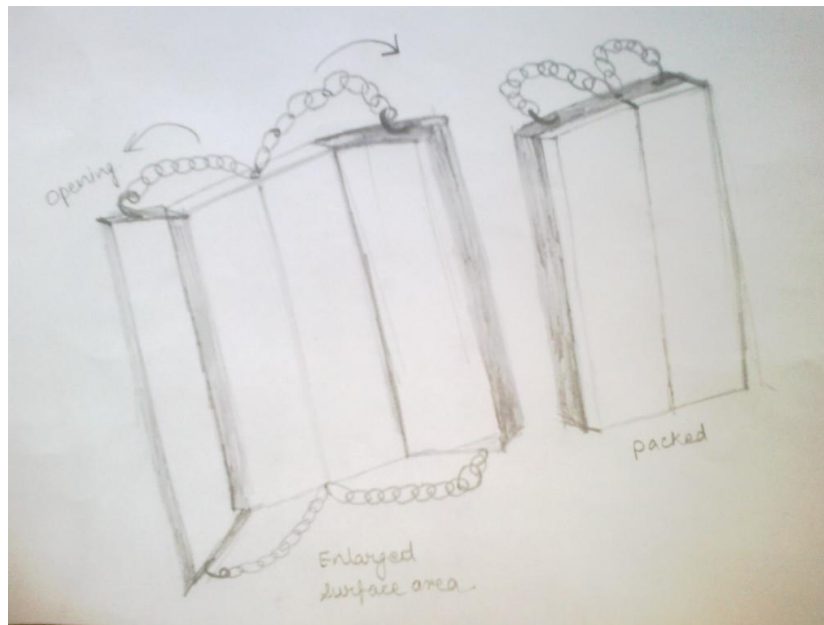

Fig.7 Platform enlarging mechanism

### 3.13 Material Selection

#### 3.13.1 Material for platform

This part of the trolley is the key part as it will be only used for placing of goods. So all the load would have to be bear by this part only. So for this part all the parameters like strength, tensile strength, hardness, toughness, young's modulus etc would have to be considered firstly. The load which the Trolley would bear will affect other parts also like wheels, chassis. As a matter of fact strength of the trolley would be directly proportional to the payload, i.e. to increase the loading capacity strength of the platform should also be increased in similar way. So this part must be made from the hard material, so it can support large payload and material should have the property with light in weight so that it can reduce the overall weight of the trolley. So the best material for the trolley which can be chose is mild Steel because it is tough and strong also.

#### Properties of Mild steel

- 1) tough
- 2) ductile
- 3) malleable
- 4) It can be case hardened to improve wear resistance.
- 5) young's modulus = 210GPa
- 6) density =  $7.85\text{g/cm}^3$

#### Chemical Composition

carbon	- .05 to 0.16 or up to .32%
silicon	- 0.4% max
sulphur	- 0.04% max
phosphorous	- 0.04% max

#### Advantage of mild steel

- 1) cheapest type of steel available.
- 2) easy to weld.

3) high tensile strength.

### *3.13.2 Pneumatic tyre wheels*

Tyre made of reinforced rubber and filled with compressed air. Usually reinforced with steel belting or other material covers this inner core and provide the contact area with the road.

## 4. Detail Design

### 4.1 Calculation of Drive Wheel Torque and Motor Selection Criteria

For selecting motor for drive wheel , a number of parameters must be considered, to calculate the maximum required torque. The calculation will be for no load condition, i.e. when there is no weight on the trolley.

Specifications for the trolley :

Gross Vehicle Weight (GVW)	= 240 kg
Radius of wheel/tire, $R_w$	= .22 m
Weight on each wheel drive ( total 4 wheel drive )	= 60 kg
Required approx. top speed, $V_{max}$	= 15 km/h = 4.12 m/s

When trolley or vehicle will be running on ground , the maximum inclination angle at worst case can be considered as  $2^0$ .

So, Inclination angle , $\alpha$	= $2^0$
Time to attain top speed can be taken as	15 sec
So, time required to attain , $t_a$	= 15 sec

top speed.

Considering the surface for normal condition as concrete of good or fair type.

For selecting motors that can produce torque of required quantity, it is important to calculate total tractive effort (TTE) , required by the trolley in moving condition.

Total Tractive Effort (TTE) is the sum of various quantities.

TTE(in kg)	= RR(in kg) +GR(in kg) + FA(in kg) .
where,	
TT	= Total Tractive Effort (kg).
RR	= force required to overcome Rolling Resistance (kg).
GR	= Grade Resistance (kg), i.e. force required to overcome inclination .
FA	= Force required to accelerate trolley to top speed (kg).

These quantities can be calculated as:

#### 1.) Rolling Resistance

It is force required in kg to overcome friction from ground and to move on any surface.

$$\text{Rolling Resistance , } RR(\text{kg}) = GVW(\text{kg}) * C_{rr}(-)$$

where,

$$GVW = \text{Gross vehicle weight in kg.}$$

$C_{rr}$  = Surface friction .  
 for concrete surface  $C_{rr}$  can be approximated as 0.0125.  
 -ve sign indicates in opposite direction.

$$RR = 240 * 0.0125$$

$$RR = 3 \text{ kg}$$

## 2.) Grade Resistance

Grade resistance is the force required to move the trolley up the slope or inclination.

$$\text{Grade Resistance, GR(kg)} = GVW(\text{kg}) * \sin\alpha$$

where,

GVW = Gross vehicle weight in kg.

$\alpha$  = Inclination angle

$$GR = 240 * \sin 2^\circ$$

$$GR = 8.38 \text{ kg}$$

## 3.) Force of Acceleration or Acceleration Force , FA

This is the force required to accelerate the trolley to the top speed in certain time interval.

$$FA (\text{kg}) = (GVW(\text{kg}) * V_{\max}) / (9.82(\text{ms}^{-2}) * t_a(\text{sec})) .$$

where,

$V_{\max}$  = Top speed in m/s.

$t_a$  = time required to attain top speed in seconds.

$$FA = (240 * 4.12) / (9.82 * 15)$$

$$FA = 6.71 \text{ kg}$$

so ,

$$RR = 3 \text{ kg}$$

$$GR = 8.38 \text{ kg}$$

$$FA = 6.71 \text{ kg}$$

$$TTE = RR + GR + FA.$$

$$TTE = 3 + 8.38 + 6.71.$$

$$TTE = 18.10 \text{ kg}$$

For verifying that the drive wheel will move or not , it is required to calculate drive wheel torque ,  $T_w$ .

$$T_w = TTE(\text{kg}) * R_w * RF(-)$$

where,

$T_w$  = Drive wheel torque in kg-m.  
 $R_w$  = Radius of wheel /tire in m.  
 RF = Resistance Factor .

Resistance factor is the frictional losses between the axle and wheel .  
 It is generally 1.1 to 1.5.

$T_w$  =  $18.10 * 0.22 * 1.15$   
 $T_w$  = 4.58 kg-m.

For verifying that the trolley can transmit the required torque from the drive wheel to ground .  
 It is necessary to calculate the Maximum Tractive Torque (MTT).

$MTT(kg-m)$  =  $W_w * \mu * R_w$ .

where,

$W_w$  = Normal load on drive wheel .  
 $R_w$  = Radius of wheel/tyre.  
 $\mu$  = Coefficient of friction between rubber and concrete .(  
 $\mu \sim 0.4$  approx.).

$MTT(kg-m)$  =  $W_w * \mu * R_w$ .  
 $MTT$  =  $60 * 0.22 * 0.4$   
 $MTT$  = 5.28 kg-m

This above MTT is for single drive wheel only. There are 4 Drive wheels, so,

Maximum Tractive Torque(MTT) for 4 wheels will be,

$MTT$  =  $4 * MTT$  for single drive wheel.  
 $MTT$  =  $4 * 5.28$ .  
 $MTT$  = 21.12 kg-m

Since from above calculations , results can be carried out.

Since  $T_w < MTT * 4$  drive wheels.

So, required torque will transmitted and trolley will move as accordingly by selecting required and sufficient motors for drive wheels.

Now on the basis of the above calculations, the motors can be selected and the torque of selected motor should be greater than drive wheel torque and total tractive effort.

## 4.2 Calculation of Torque in Loaded Condition.

The loads on the trolley can be applied 100's or multiple of 100's . So starting with calculation of torque required for moving the trolley.

1.) 100 kg Load

$$\begin{aligned} \text{here, GVW} &= 340 \text{ kg} \\ \text{RR} &= 340 * 0.0125 \\ \text{RR} &= 4.25 \text{ kg} \\ \\ \text{GR} &= 340 * \sin^2 0 \\ \text{GR} &= 11.86 \text{ kg} \\ \\ \text{FA} &= (340 * 4.12) / (9.82 * 15) \\ \text{FA} &= 9.50 \text{ kg.} \\ \\ \text{TTE} &= \text{RR} + \text{GR} + \text{FA} \\ \text{TTE} &= 4.25 + 11.86 + 9.50 \\ &= 25.61 \text{ kg} \\ \\ \text{T}_w &= \text{TTE} * \text{R}_w * \text{RF} \\ \text{T}_w &= 25.61 * .22 * 1.15 \\ &= 6.47 \text{ kg-m} \end{aligned}$$

as  $T_w < \text{MTT} * 4$  drive wheels.

So, required torque will be transmitted to the ground and there will be no occurrence of slipping.

2.) 200 kg Load

$$\begin{aligned} \text{here, GVW} &= 440 \text{ kg} \\ \text{RR} &= 440 * 0.0125 \\ \text{RR} &= 5.5 \text{ kg} \\ \\ \text{GR} &= 440 * \sin^2 0 \\ \text{GR} &= 15.35 \text{ kg} \\ \\ \text{FA} &= (440 * 4.12) / (9.82 * 15) \\ \text{FA} &= 12.30 \text{ kg.} \\ \\ \text{TTE} &= \text{RR} + \text{GR} + \text{FA} \\ \text{TTE} &= 5.5 + 15.35 + 12.30 \\ &= 33.15 \text{ kg} \\ \\ \text{T}_w &= \text{TTE} * \text{R}_w * \text{RF} \\ \text{T}_w &= 33.15 * .22 * 1.15 \\ &= 8.38 \text{ kg-m} \end{aligned}$$



as  $T_w < MTT * 4$  drive wheels.

So, required torque will be transmitted to the ground and there will be no occurrence of slipping.

3.) 300 kg Load

$$\begin{aligned} \text{here, GVW} &= 540 \text{ kg} \\ \text{RR} &= 540 * 0.0125 \\ \text{RR} &= 6.75 \text{ kg} \\ \\ \text{GR} &= 540 * \sin^2 0 \\ \text{GR} &= 18.84 \text{ kg} \\ \\ \text{FA} &= (540 * 4.12) / (9.82 * 15) \\ \text{FA} &= 15.10 \text{ kg.} \\ \\ \text{TTE} &= \text{RR} + \text{GR} + \text{FA} \\ \text{TTE} &= 6.75 + 18.84 + 15.1 \\ &= 40.69 \text{ kg} \\ \\ \text{T}_w &= \text{TTE} * R_w * R_F \\ \text{T}_w &= 40.69 * .22 * 1.15 \\ &= 10.29 \text{ kg-m} \end{aligned}$$

as  $T_w < MTT * 4$  drive wheels.

So, required torque will be transmitted to the ground and there will be no occurrence of slipping.

4.) 400 kg Load

$$\begin{aligned} \text{here, GVW} &= 640 \text{ kg} \\ \text{RR} &= 640 * 0.0125 \\ \text{RR} &= 8 \text{ kg} \\ \\ \text{GR} &= 640 * \sin^2 0 \\ \text{GR} &= 22.33 \text{ kg} \\ \\ \text{FA} &= (640 * 4.12) / (9.82 * 15) \\ \text{FA} &= 17.9 \text{ kg.} \\ \\ \text{TTE} &= \text{RR} + \text{GR} + \text{FA} \\ \text{TTE} &= 8 + 22.33 + 17.9 \\ &= 48.23 \text{ kg} \end{aligned}$$

$$T_w = TTE * R_w * RF$$

$$T_w = 48.23 * .22 * 1.15$$

$$= 12.20 \text{ kg-m}$$

as  $T_w < MTT * 4$  drive wheels.

So, required torque will be transmitted to the ground and there will be no occurrence of slipping.

Maximum loading capacity , when torque can be transmitted to ground.

$$\text{MTT for 4 wheels} = 21.12 \text{ kg-m.}$$

$$\text{so, let } T_w \text{ (max).} = 21 \text{ kg-m approx.}$$

$$TTE = T_w / (.22 * 1.15)$$

$$TTE = 21 / (.22 * 1.15)$$

$$TTE = 83 \text{ kg}$$

$$TTE = RR + GR + FA$$

$$83 = GVW * (.0125 + \sin^2 \theta + 4.12 / (9.82 * 15))$$

$$83 = GVW * (0.0125 + 0.0349 + 0.028)$$

$$83 = GVW * 0.0754$$

$$GVW = 1100.795$$

So, maximum capacity will be (GVW - 240) , i.e. around 850 kg.

So, according to above calculations , the maximum load that can be carried by trolley will be less than 850 kg . Therefore around 800 kg maximum load can be carried without any slipping.

The above calculations were for inclination case included in torque determining. Generally inclination will be less , so torque required will be also be reduced.

**Table 2 Tabular Data of Drive wheel torque and load.**

S.No.	LOAD	Torque Required
1	0 kg (GVW=240) , when there is no load on the trolley.	4.58 kg-m
2	100	6.47 kg-m
3	200	8.38 kg-m
4	300	10.29 kg-m
5	400	12.29 kg-m
6	Max. capacity of trolley , 800 kg	21 kg-m

### 4.3 Motor Selection Criteria

By above calculations of torque required and MTT , the required motor can be selected . The dc motor will be best suited for the above design.

Specifications of selected dc motors

Double Reduction Globe Motor.

Voltage rating = 12 V dc

Current rating	= 130 mA (no load)
Speed	= 4.5 RPM (no load)
Torque	= 125 to 150 in-lb
Reversible	
Weight	= 2 kg approx.

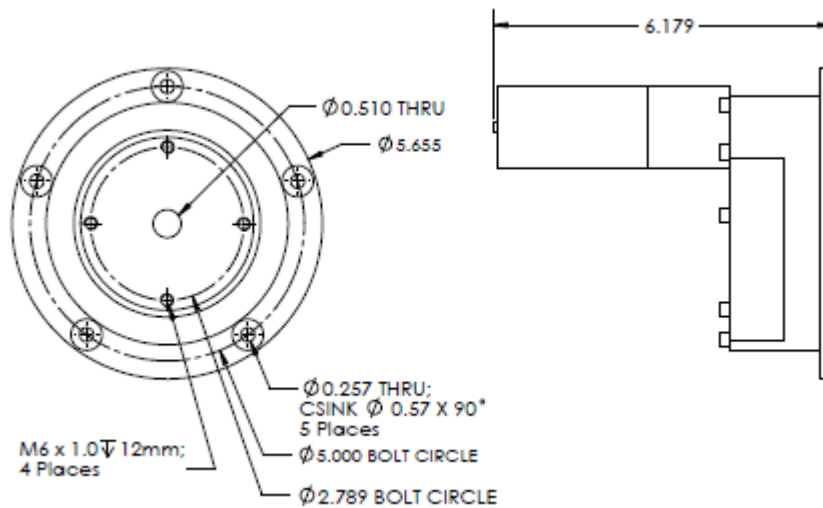

Fig.8 Design of selected motor

#### 4.4 Static Structural Analysis of Platform During Loading Conditions

Material of Platform	= Steel
Density	= 7850 kgm <sup>-3</sup>
Tensile Yield Strength	= 2.5*10 <sup>8</sup> Pa
Comp. Yield Strength	= 2.5*10 <sup>8</sup> Pa
Tensile Ultimate Strength	= 4.6*10 <sup>8</sup> Pa
Comp. Ultimate Strength	= 0
Young's Modulus	= 2*10 <sup>11</sup> Pa
Poisson's Ratio	= 0.3
Bulk Modulus	= 1.666*10 <sup>11</sup> Pa
Shear Modulus	= 7.692*10 <sup>10</sup> Pa

During analysis , fixed support is provided on the bottom side and cylindrical support is provided on the bottom bars.

##### 1. No Load condition (force applied is 0 )

Force Applied	= 0 N
Results	
Total Deformation	= 5.6842*10 <sup>-11</sup> mm
Equivalent Stress	= 8.0889*10 <sup>-7</sup> MPa
Factor of safety	= 15 maximum over time

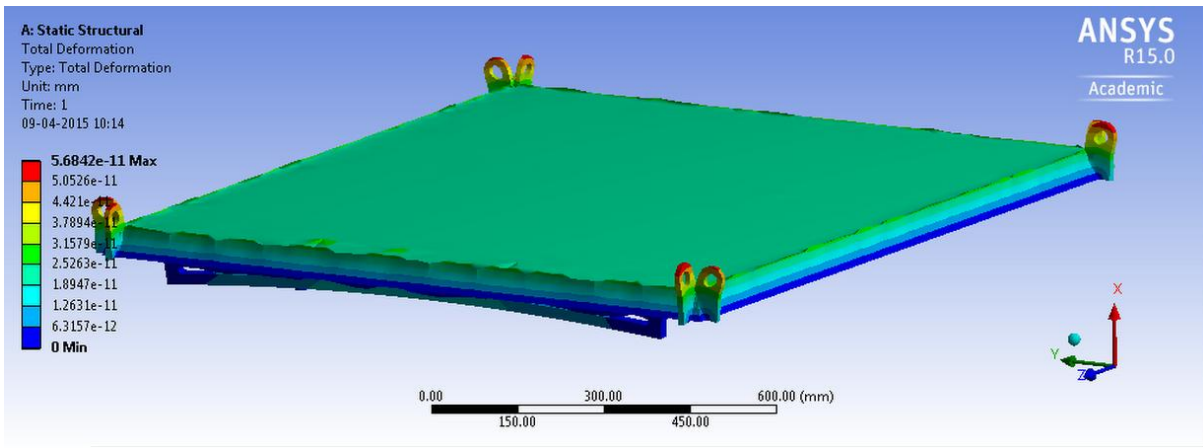

Fig.9 Deformation of Platform in ANSYS

2. 100 kg Load

Force Applied	= 1000 N
Results	
Total Deformation	= $5.6842 \times 10^{-8}$ mm
Equivalent Stress	= 0.00080889 MPa
Factor of safety	= 15 maximum over time

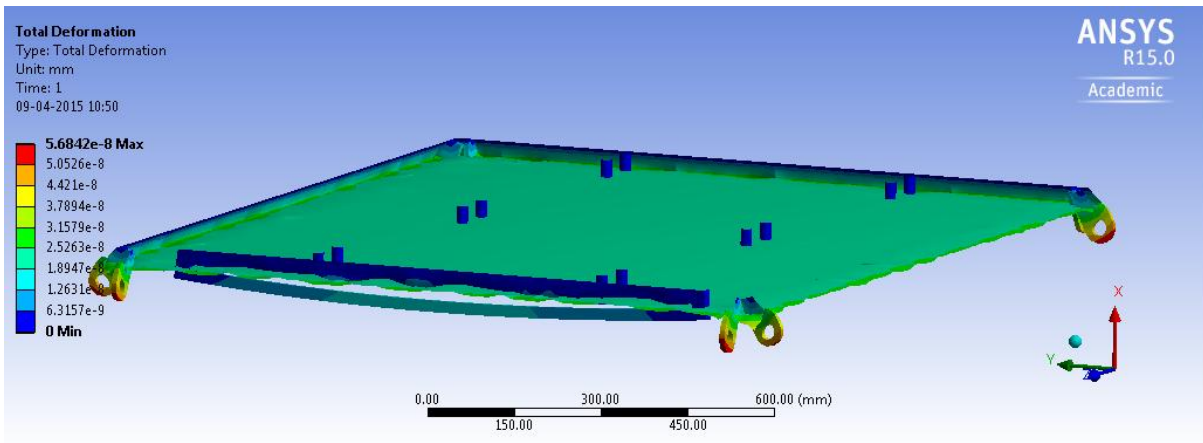

Fig.10 Deformation of Platform in ANSYS

3. 200 kg Load

Force Applied	= 2000 N
Results	
Total Deformation	= $1.1368 \times 10^{-7}$ mm
Equivalent Stress	= 0.0016178 MPa
Factor of safety	= 15 maximum over time

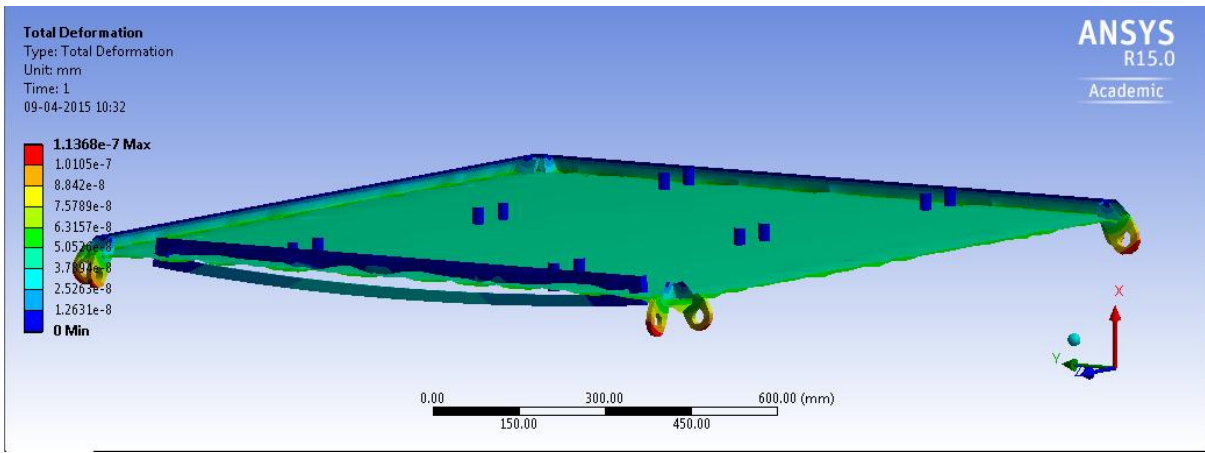

Fig.11 Deformation of Platform in ANSYS

4. 400 kg Load

Force Applied	= 4000 N
Results	
Total Deformation	= $2.2737 \times 10^{-7}$ mm
Equivalent Stress	= 0.0032356 MPa
Factor of safety	= 15 maximum over time

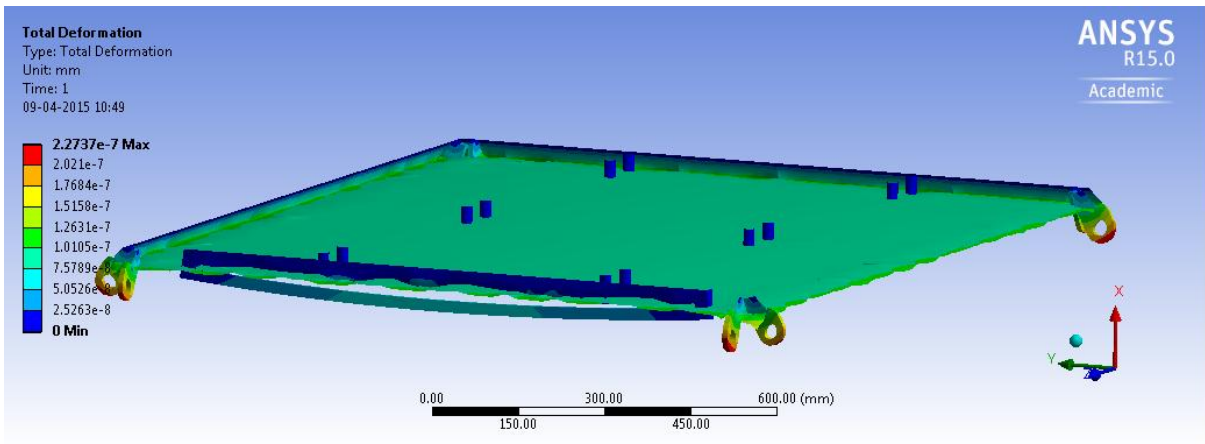

Fig.12 Deformation of Platform in ANSYS

5. 500 kg Load

Force Applied	= 5000 N
Results	
Total Deformation	= $2.8421 \times 10^{-7}$ mm
Equivalent Stress	= 0.0040445 MPa
Factor of safety	= 15 maximum over time

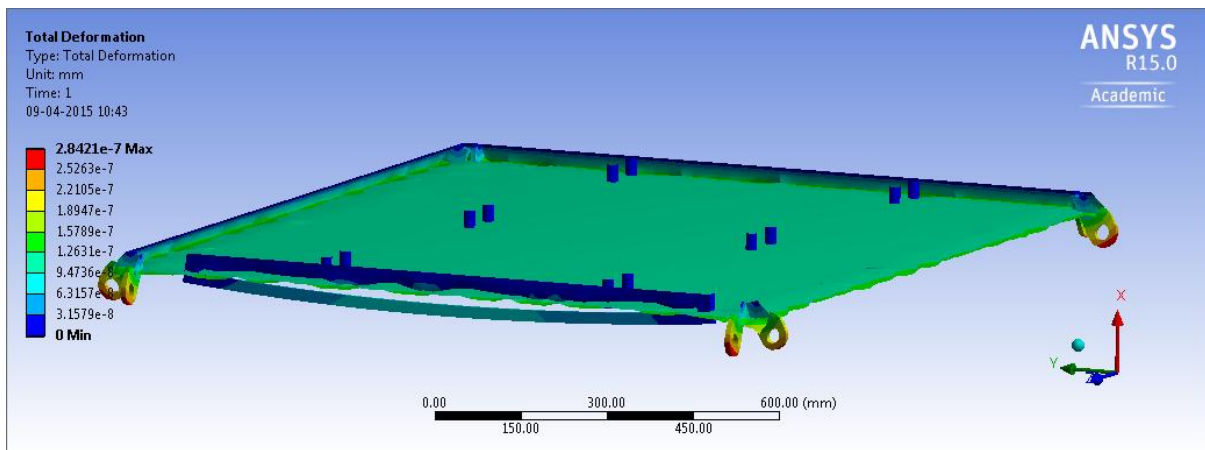

Fig.13 Deformation of Platform in ANSYS

6. 800 kg Load

Force Applied	= 8000 N
Results	
Total Deformation	= $4.5473 \times 10^{-3}$ mm
Equivalent Stress	= 0.0064711 MPa
Factor of safety	= 15 maximum over time

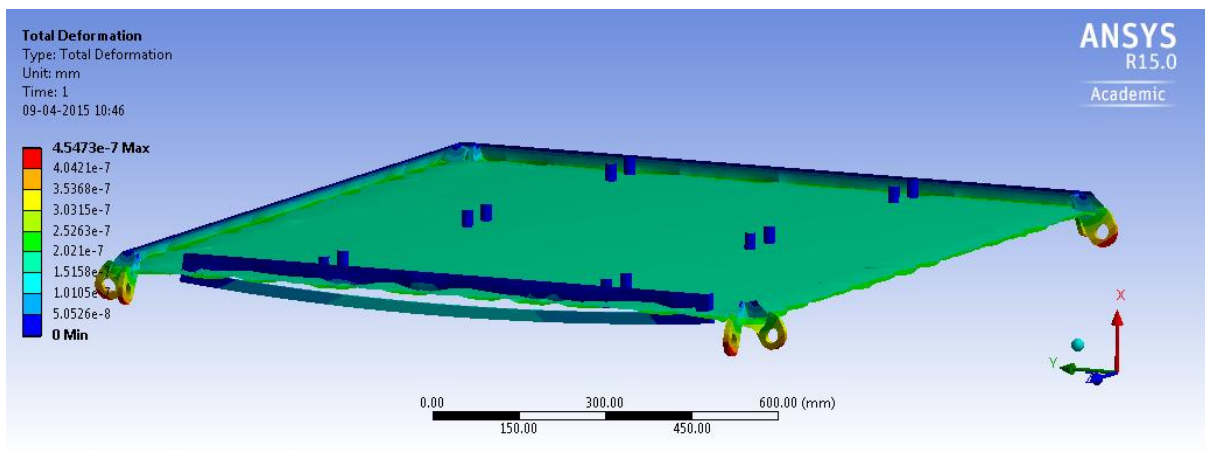

Fig.14 Deformation of Platform in ANSYS

#### 4.5 Calculation of Torque Required for Screw Jack

Drive torque , $T_d$	= $\{(F[\text{KN}] \cdot P[\text{mm}] / (2 \cdot \pi \cdot \eta_{\text{gear}} \cdot \eta_{\text{screw}}) + M_L[\text{Nm}])\}$
where,	
F	= Load to lift(KN)
P	= Pitch of Screw(mm)
$\eta_{\text{gear}}$	= Gear efficiency ~ 0.87
$\eta_{\text{screw}}$	= Screw efficiency ~ 0.391
i	= Drive ratio for screw jack ~ 4
$M_L$	= Idling Torque = 0.36 Nm approx.

Drive torque , $T_d$	= $\{(8 \cdot 2.5) / (2 \cdot \pi \cdot 0.391 \cdot 0.87 \cdot 4) + 0.36\}$
	= 2.699 Nm.

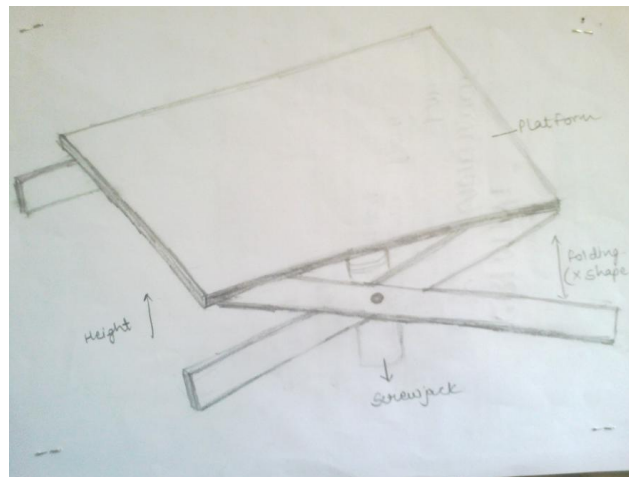

Fig.15 Screw Jack Mechanism

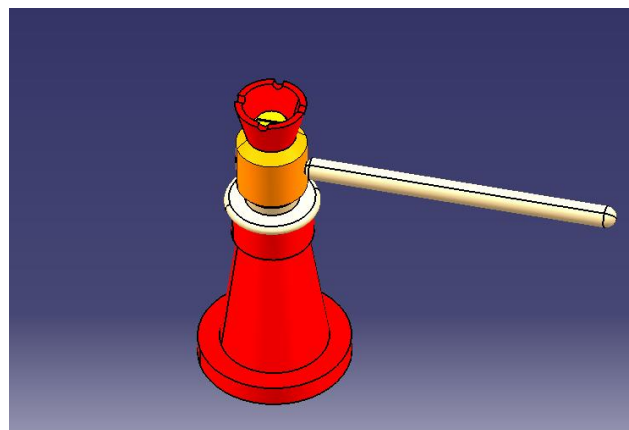

Fig.16 CAD model of screw jack

#### 4.6 Grip Dimensions

In hill agriculture most of the tools are manually driven, so proper grip is required for effective force application while working with these tools. The grip dimensions of most of the hand tools such as *dao*, weeders, handles of wheel hoe, etc need to be relooked based on anthropometric dimensions. The 5<sup>th</sup>, 50<sup>th</sup> and 95<sup>th</sup> percentile values of grip diameter (inside) of male and female agricultural workers of Meghalaya was found as 3.7, 4.2 and 4.7 cm for male and 3.3, 3.6 and 4.1 cm for female workers, respectively. The comfortable holding of the grip needs to be designed in such a way that a person with 5<sup>th</sup> percentile body dimensions could properly grip the handle. Therefore, the minimum diameter of the grip should be 3.7 cm for male and 3.3 cm for female workers.

#### 4.7 Handle Holding Height

The handle holding height depends upon the elbow height of the population and permitted range of elbow angle. The comfortable range of elbow angle should be 100-110°. The elbow height (standing) for male and female agricultural workers of Meghalaya was found to be 94.7, 101.6 and 107.6 and 90.6, 96.1 and 101.2 cm for 5<sup>th</sup>, 50<sup>th</sup> and 95<sup>th</sup> percentile,

respectively. With known elbow grip length, the handle height at given elbow angle of 100-110° can be calculated. At 100° elbow angle, the handle height should be 89.5 cm for male and 85.7 cm for female workers with 5<sup>th</sup> percentile body dimensions. Workers with 95<sup>th</sup> percentile body dimension the handle height should be 95.6 and 101.2 cm above ground for male and female workers respectively. In order to maintain elbow angle 110° the corresponding handle heights 81.0 and 84.6 cm for 5<sup>th</sup> percentile and 89 and 95.6 cm for 95<sup>th</sup> percentile for male and female workers. However, in case of implements such as wheel hoe, which has certain working depth, necessary correction needs to be made in handle height to have comfortable holding height in working condition.

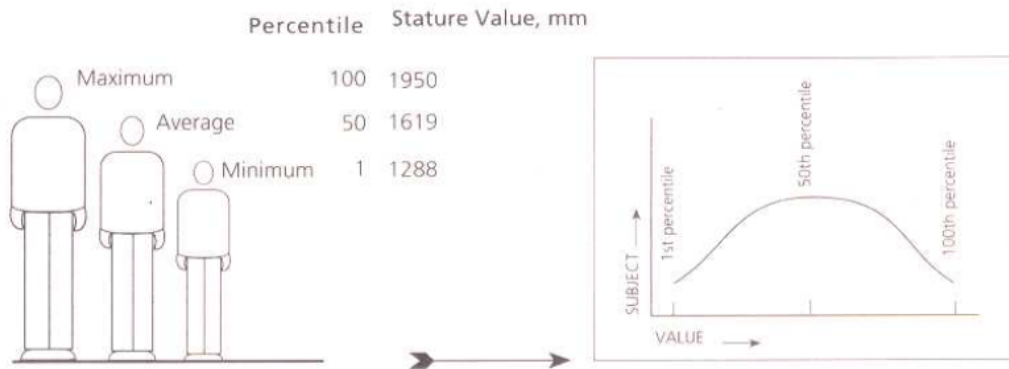

Fig.17 Percentile value and normal distribution graph

#### 4.8 Concept Selection

Various concepts which were made as sketches by considering various designing factors , the final sketch which is selected for making CAD model and making prototype is depicted below.

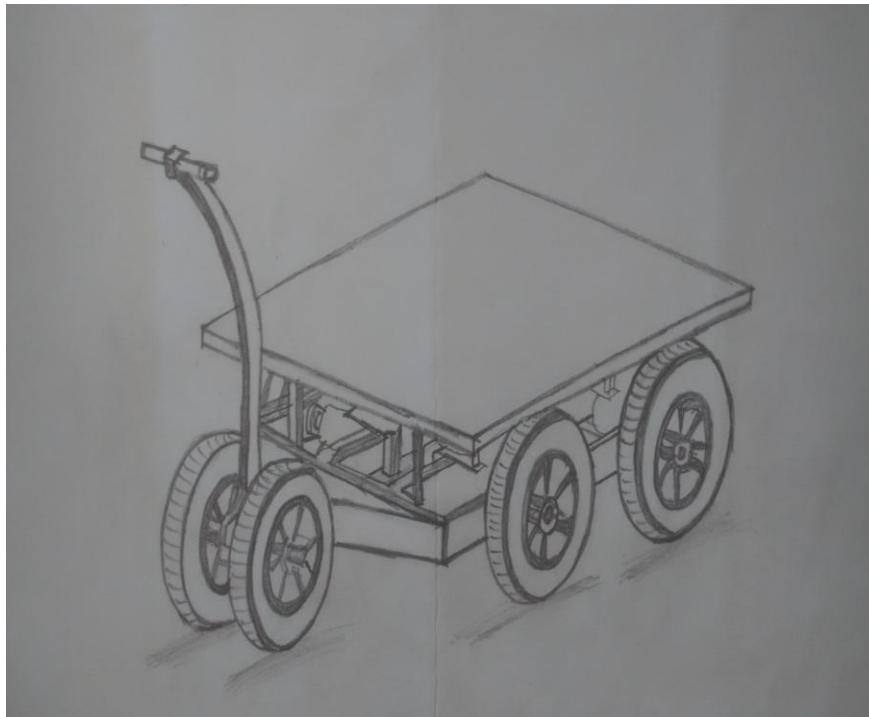

Fig.18 Concept selection



#### 4.9 CAD Model

The below figure which is shown below depicts the CAD model made in CATIA V5 software. This figure is fully rendered and various parts were attached so as to make the final assembly.

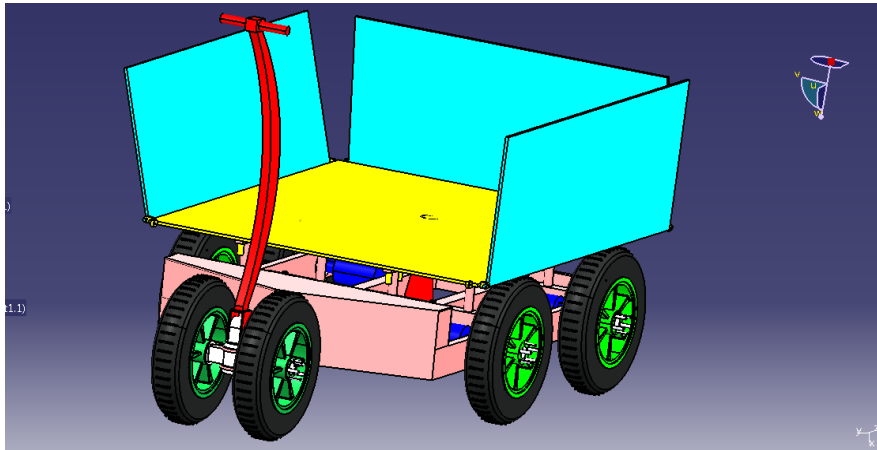

Fig.19 CAD model generated in CATIA V5

## 5. RESULTS AND DISCUSSIONS

The results can be discussed as the design process is completed. The CAD model is generated as it can be seen in fig. 18 and digital mock up is also generated in the same figure. Also a physical prototype is also developed using wood motors but in reduced scale. Some of the specifications of the trolley can now be discussed as :

Weight of trolley	= 240 kg approx
Dimensions of trolley	= 2m*1.3m*1m approx.
Motor Rating	= 125-150 in-lb, 12 V dc
Lift produced by screw jack	= up to 50cm approx.
Dimensions of platform	= 1.5m*1.2m*0.01m
Capacity of trolley	= 800 kg approx.

The trolley can be moved automatically but steering will be manual, as well as platform can be enlarged by using the area of the side walls in needed. There is also a place is provided for the driver to stand and run the trolley just by controlling front handle to maintain speed and to steer left and right . The reverse motion is also possible just by using reverse polarity of current in motors. Loading and unloading is manual and should be performed , keeping in mind the capacity of the trolley.

## **6. CONCLUSIONS**

An Automatic trolley with all dimensional constraint is designed. Likewise, the 3D model of the trolley is designed in the CATIA V5 R19 Software with isometric view generated as well as with the rendered view. The trolley is designed consisting of the motors. Various drawbacks which were present in the existed models were removed like manual work was reduced as well as the steering mechanism was improved so that the worker would be easily able to perform the steering with ease. Also the focus was emphasized on the cost and weight of the trolley which was maintained as per the requirement of an individual. Screw jack mechanism is also provided to adjust the height of the platform as per requirement.

## REFERENCES

1. Karim Abdel-Malek, Wei Yu, Jingzhou Yang, Kyle Nebel. 2004 A mathematical method for ergonomic-based design: placement. *International Journal of Industrial Ergonomics* 34 (6) 375–394.
2. Uli Schmucker, Rakhi Dandona, G. Anil Kumar, Lalit Dandon. 2011. Crashes involving motorised rickshaws in urban India: Characteristics and injury patterns. 42 (6) 104–111.
3. Paolo Gallina, 2005 Vibration in screw jack mechanisms: experimental results. 282 (4) 1025–1041.
4. Yunhua Li, Mingsheng Liu, Josephine Lau, Bei Zhang. 2015. A novel method to determine the motor efficiency under variable speed operations and partial load conditions. *Applied Energy* 144 (3) 234–24.
5. R.S. Khurmi, J.K. Gupta, *Machine Design*, 2013, S.chand & company Ltd.
6. Chakravarty D K., *Indian Anthropometric Dimensions*. 1987., National Institute of Design Press.
7. [http://en.wikipedia.org/wiki/trolley\\_Part](http://en.wikipedia.org/wiki/trolley_Part) [Accessed on 17th Nov 2014].
8. Snook, S.H., Ciriello, V.M., 1991. The design of manual handling tasks: revised tables of maximum acceptable weights and forces. *Ergonomics* 34, 1197–1213.
9. Anthropometric survey of agricultural workers of Orissa state.2002. Annual Report of AICRP on Human Engineering and Safety Analysis, OUAT, Orissa Centre. Orissa University of Agriculture and Technology, Bhubneshwar.