

CFD ANALYSIS OF RIB TURBULATED COOLING IN GAS TURBINE BLADES

*A thesis submitted in partial fulfilment of the
requirements for the degree of*

Bachelor of Technology

In

Mechanical Engineering

By

Yugesh Patnaik

(111ME0331)



Department of Mechanical Engineering
National Institute of Technology, Rourkela
Rourkela, Odisha – 769008

Declaration

I hereby declare that this thesis is my own work and effort. Throughout this documentation wherever contributions of others are involved, every effort was made to acknowledge this clearly with due reference to literature. This work is being submitted for meeting the partial fulfilment for the degree of Bachelor of Technology in Mechanical Engineering at National Institute of Technology, Rourkela for the Academic Session 2011 – 2015.

Yugesh Patnaik (111ME0331)



NATIONAL INSTITUTE OF TECHNOLOGY

ROURKELA 769008, INDIA

Certificate of Approval

This is to certify that the thesis entitled “**CFD ANALYSIS OF RIB TURBULATED COOLING IN GAS TURBINE BLADES**” submitted to the National Institute of Technology, Rourkela by **YUGESH PATNAIK, Roll Number 111ME0331**, for the award of the Degree of Bachelor of Technology in Mechanical Engineering is a record of bona fide research work carried out by him under my supervision and guidance. The results presented in this thesis has not been, to the best of my knowledge, submitted to any other University or Institute for the award of any degree or diploma. The thesis, in my opinion, has reached the standards fulfilling the requirement for the award of the degree of Bachelor of Technology in accordance with regulations of the Institute.

Dr. Ashok Kumar Satapathy

Associate Professor

Department of Mechanical Engineering

Date: 06/05/2015

National Institute of Technology, Rourkela

Acknowledgement

This project would not have been possible, in spite of my best efforts, without the kind support and help of many individuals and the department. I would like to extend my sincere thanks to all of them.

I would like to express our gratitude and special thanks to my project guide Dr Ashok Kumar Satapathy, Associate Professor, Department of Mechanical Engineering, National Institute of Technology, Rourkela, for all the cooperation and time. I would also like to thank Mr. Vishnu, an M.Tech student in the Department of Mechanical Engineering, National Institute of Technology, Rourkela for taking the time to help me solve the various problems that I faced during the course of my work.

My special thanks to Dr. Siba Sankar Mahapatra, Head of Department, Department of Mechanical Engineering, National Institute of Technology, Rourkela for his support and enthusiasm.

Yugesh Patnaik(111ME0331)

Abstract

Gas Turbines are designed to continuously and efficiently generate useful power from fuel energy and are developed into very reliable high performance engines. Nowadays gas turbines have been put to use in various fields like, power plants, marine industries as well as for industrial propulsion. For high thermal efficiency advanced gas turbines use high temperature at the entry of the turbine. Therefore, for the purpose of increasing thermal efficiency of the turbines, it is imperative to design effective cooling schemes. The current Turbine Inlet Temperature in advanced gas turbines is much higher than the melting point of the blade material. As a result a varied range of cooling techniques are used to cool the blade to maintain normal operation of the turbine.

An attempt has been made to computationally analyse the effects of one type of cooling system, rib turbulated cooling, wherein the cooling effects of air flow through a ribbed turbine blade passage has been simulated using ANSYS-FLUENT. The mass flow rates of air through the passage was varied to observe the variation of cooling effects with mass flow rate and results were compared. The temperature contours of the blade for different mass flow rates were observed. The trends of different parameters like heat transfer coefficient, Nusselt number, skin friction coefficient was also noted. It was noted that although the cooling effects increase with increasing mass flow rate, the pressure loss due to friction also increases and hence it is not feasible to have high mass flow rates for cooling turbine blades.

Table of Contents

1	Introduction	1
1.1	Gas Turbine Basics.....	1
1.2	Limitations on Turbine Inlet Temperature (TIT)	1
1.3	Need for cooling.....	2
1.4	Turbine Cooling Basics	2
1.4.1	Types of Cooling.....	2
1.4.2	Types of Internal Cooling	3
2	Literature Survey	5
3	Methodology.....	7
3.1	Geometry.....	7
3.2	Mesh.....	8
3.3	Setup.....	8
3.3.1	Boundary Conditions	9
3.3.2	Solution Method.....	9
4	Results.....	10
4.1	Temperature Contours of Blades.....	10
4.2	Temperature of Fluid Domain.....	14
4.3	Average Rib Temperature Trend.....	15
4.4	Average Nusselt Number Trends	16
4.5	Average Heat Transfer Coefficient Trends	16
4.6	Average Skin Friction Coefficient Trends	17
4.7	Average Blade Temperature Trend	17
5	Discussions.....	18
5.1	Comparison with Smooth Channel	18
5.2	Comparison for different values of mass flow rate.....	19
6	Conclusion	20

Figure 1.1-1: Schematic of Gas Turbine.....	1
Figure 1.4-1: Mechanism of Rib Turbulated Cooling	4
Figure 3.1-1: Turbine Blade Body	7
Figure 3.1-2: Fluid Flow Domain	7
Figure 4.1-1: Temperature contour at outlet of the passage for $m = 0.01$ kg/s.....	10
Figure 4.1-2: Temperature contour of the blade body for $m = 0.01$ kg/s	11
Figure 4.1-3: Temperature contour of the blade body for $m = 0.02$ kg/s	11
Figure 4.1-4: Temperature contour at the outlet of the passage for $m = 0.02$ kg/s.....	11
Figure 4.1-5: Temperature contour of the blade body for $m = 0.03$ kg/s	12
Figure 4.1-6: Temperature contour at outlet of the passage for $m = 0.03$ kg/s.....	12
Figure 4.1-7: Temperature contour of the blade body for $m = 0.04$ kg/s	12
Figure 4.1-8: Temperature contour at outlet of the passage for $m = 0.04$ kg/s.....	13
Figure 4.1-9: Temperature contour of the blade body for $m = 0.05$ kg/s	13
Figure 4.1-10: Temperature contour at outlet of the passage for $m = 0.05$ kg/s.....	13
Figure 4.2-1: Temperature contour of the fluid domain for $m = 0.01$ kg/s	14
Figure 4.2-2: Temperature contour of the fluid domain for $m = 0.02$ kg/s	14
Figure 4.2-3: Temperature contour of the fluid domain for $m = 0.03$ kg/s	14
Figure 4.2-4: Temperature contour of the fluid domain for $m = 0.04$ kg/s	15
Figure 4.2-5: Temperature contour of the fluid domain for $m = 0.05$ kg/s	15
Figure 4.3-1: Variation of average rib temperature, for various mass flow rates.....	15
Figure 4.4-1: Variation of Nusselt number, for different mass flow rates.....	16
Figure 4.5-1: Variation of Average heat transfer coefficient, for different mass flow rates ...	16
Figure 4.6-1: Variation of average skin friction coefficient, for different mass flow rates.....	17
Figure 4.7-1: Variation of average blade temperature, for different mass flow rates.....	17
Figure 5.1-1: The four points E, F, G, H selected around the channel inlet	18

1 Introduction

1.1 Gas Turbine Basics

There are three main parts of a gas turbine, namely: the compressor, the combustor and the turbine, as represented in Figure 1.1-1 by the numbers (1), (2) and (3) respectively. The function of the compressor is to pressurise the air before the air goes into the combustion chamber, where it is mixed with fuel and is ignited. This fuel-air mixture burns at high temperatures and expands. Thereafter the hot gas enters the turbine and strikes the vane, which directs the incoming gas to the blade. The blade is deflected by the oncoming gas stream and thus a torque is produced on the shaft causing it to rotate which is then converted into useful work. One use of this rotational movement is to produce electricity by rotating a generator (4) and then stepping up by using a transformer (5).

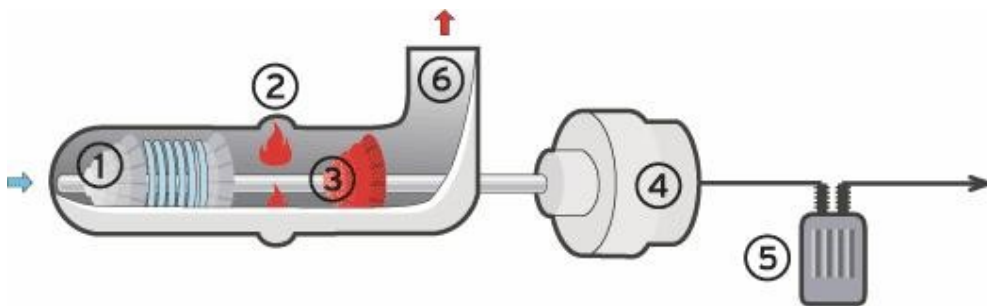

Figure 1.1-1: Schematic of Gas Turbine

1.2 Limitations on Turbine Inlet Temperature (TIT)

Due to the nature of its working, the power generated by a turbine increases with increasing the temperature at which the gas enters, called the turbine inlet temperature. An increased power output results in a higher efficiency. However, the turbine inlet temperature cannot be increased arbitrarily because of the limits imposed due to the temperature at which the blade material melts. Although advances have been made in material science to make new alloys having high melting points that can withstand operation at such high temperatures without failing, these materials are expensive and are difficult to machine.

1.3 Need for cooling

As the blade material melts at a lower temperature than the operating conditions of the turbine, a cooling method must be incorporated into the blade design to ensure the safe and smooth running of the turbine. It is important, while devising a cooling scheme, to have knowledge about the boundary conditions of the blade during turbine operation, so that large gradients can be avoided. This is because large gradients cause thermal stress cutting the component life short significantly.

1.4 Turbine Cooling Basics

Although cooling is necessary, it affects the gas turbine operation inadvertently:

1. The cooling air supplied to the blades and vanes is directly bled from the compressor. As a result the mass of air going into the combustor is decreased.
2. In order to incorporate the various structures like fins, cooling passages etc. the trailing edge thickness of the blades must be increased which adversely affects the aerodynamic performance of the blades

Various parts of the turbine blade are cooled using various techniques. The front part, called the leading edge, is generally cooled by impingement cooling. The middle part is generally cooled by using snake-like passages endowed with ribs along with local film cooling. The back part, called the trailing edge, is generally cooled by impingement and film cooling.

1.4.1 Types of Cooling

There are two broad categories of cooling used in gas turbine blades:

1. Internal Cooling
2. External Cooling

In internal cooling, the cool compressed air flows internally within the passages of the turbine blade and thus heat transfer occurs between the cold air in the passage and the adjacent hot surface of the blade.

In external cooling, the cool compressed air is ejected from holes on the surface of the blade or the vane and creates a thin film between the surroundings and the blade surface thus preventing contact between the hot air and the blade surface, enhancing heat transfer.

1.4.2 Types of Internal Cooling

There are various types of internal cooling which have been developed over the years. No particular type of cooling is suitable for all blades for all applications. Thus the cooling scheme must be selected according to operating conditions and requirements of the application at hand.

1.4.2.1 Impingement Cooling

It is generally used near the leading edge of the airfoils where the jet of cooling air strikes the inside of the blade surface and hence the name impingement cooling. This techniques can also be used in the middle part of the blade.

The heat transfer characteristics of this kind of cooling depends on the size and distribution of jet holes, cross-section of the cooling channel and the surface area of the target face.^[1]

1.4.2.2 Pin Fin Cooling

Since the trailing edge of the blade is very narrow, it is difficult to manufacture holes and passages in this portion, thus pin fin cooling is generally applied in this region. The flow around the pins is similar to flow around a cylinder. The air flow separates and the wakes are shed downstream. Moreover a horse shoe vortex also forms wrapping around the fins and creating additional mixing and thus enhancing heat transfer.

The heat transfer characteristics largely depend on the type of fin array and the spacing of the pins in the array, the pin shape and size.^[1]

1.4.2.3 Dimple Cooling

This type of cooling occurs due to the presence of concave depressions or indentations on the surfaces of the blade passage. They induce flow separation and reattachment and thus enhance heat transfer.

They are a very desirable cooling technique as they have low pressure losses.^[1]

1.4.2.4 Rib Turbulated Cooling

This type of cooling requires the usage of turbulence promoting structures on the walls of the cooling passage in the blades, which are cast along with the blade during manufacturing.

Heat conducted through the blade wall is transferred to the coolant passing internally through the blade.

The heat transfer characteristics largely depend on the aspect ratio of channel, rib configurations and Reynolds number of the coolant flow. [1]

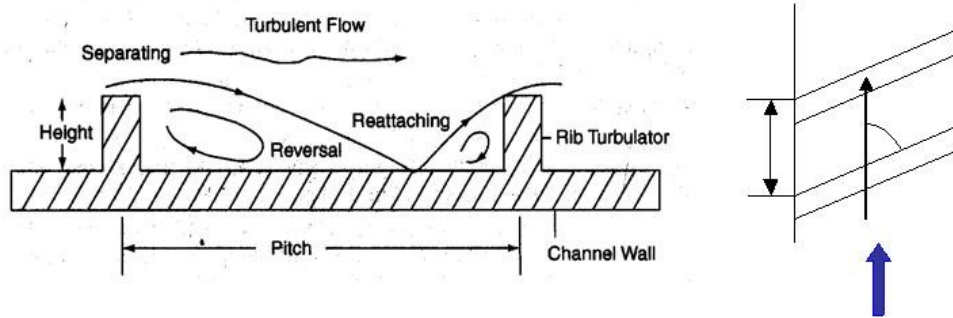

Figure 1.4-1: Mechanism of Rib Turbulated Cooling

2 Literature Survey

It has been shown through extensive study of the coolant flow through a stationary ribbed channel that the flow near the channel wall separates followed by reattachment and the resulting turbulence generated enhances heat transfer. [2, 3] If the ribs are skewed to the mainstream direction, counter-rotating vortices are formed. The use of V-shape ribs results in four such vortices and hence more heat transfer. The pressure drop penalties of the ribs are affordable because only the flow near the walls of the channel are affected.

Zhang et al found out in their study of characteristics of heat transfer and friction in channels of rectangular cross-section, equipped with rib-grooved combinations that Stanton Numbers of such channels are higher than only channels which have been endowed with ribs. [4]

Liou et al found in their study that ribs having a pitch-to-height ratio of 10 showed the best heat transfer characteristics. Moreover, the heat transfer coefficient increases with decreased rib spacing. [5]

In addition to confirming Han et al's findings, Taslim et al found that square and trapezoid ribs enhanced the heat transfer coefficient and thermal performance factors even more. [6]

Acharya et al found out in their study of square two-pass rotating channel with various profile ribs placed on leading and trailing surfaces that staggered angle, V and W-shaped ribs provide better heat transfer enhancement than the conventional square ribs. [7]

Johnson et al studied the effects of buoyancy and Coriolis forces on the flow of air in rotating passages and found that such factors affected heat transfer less when the ribs were skewed by 45°. [8]

Wright et al. showed that the rotating channel with discrete V-shaped ribs have better heat transfer characteristics than the V-shaped and angled ribbed channels. However, the W-shaped and discrete W-shaped ribs resulted in more heat transfer than the discrete V-shaped ribs. These two configurations resulted in greatest pressure drop of the six configurations considered. [9]

Chaube et al examined nine different shapes of ribs using CFD code FLUENT 6.1 with SST $k-\omega$ model and compared with experimental results and found good matching between the two sets of results. [10]

Kini et al conducted analysis of a cycloidal passage used for cooling turbine blades with helical ribs on its walls and found that it resulted in an augmented surface for convection and heat dissipation and also in less thermal stress. ^[11]

Al-Kayiem et al also conducted a simulation of flow of air through a ribbed wall cooling passage using CFD code FLUENT and calculated the rib-efficiency of the ribbed channels. ^[12]

3 Methodology

3.1 Geometry

The blade profile was generated using ANSYS- Design Modeller software. The cross-section of the blade was made by importing 374 points from a patent ^[13] and then drawing a spline using those points. The spline was then extruded to a length of 150 mm.

The cooling channel was constructed as per specifications used in ^[12]. The cross-section of the cooling channel was rectangular with length 18 mm and breadth 9 mm. Ribs were made on one side of the cooling channel with a height (e) of 0.936 mm and spacing between ribs, pitch (p) of 7.488 mm. 18 such ribs were made. The hydraulic diameter(D_h) of the channel was calculated to be 12 mm and the rib blockage ratio (e/D_h) was taken to be 0.078.

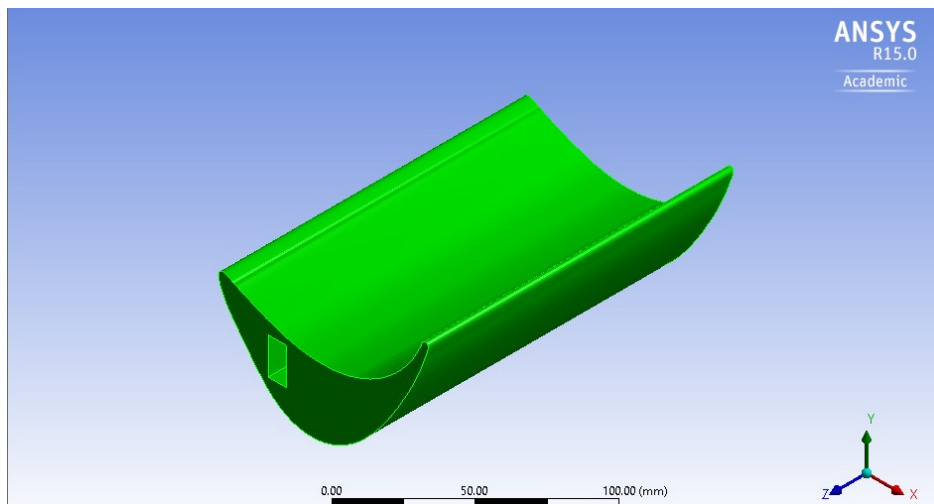

Figure 3.1-1: Turbine Blade Body

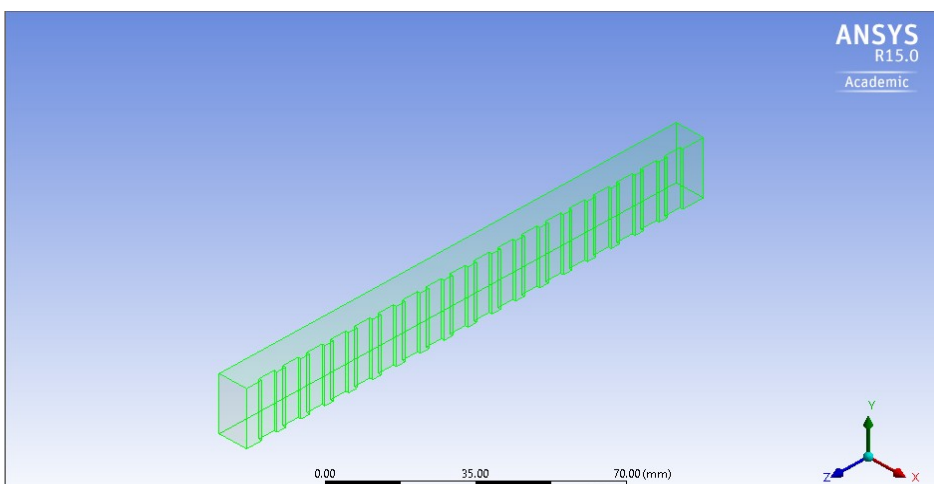

Figure 3.1-2: Fluid Flow Domain

3.2 Mesh

The geometry was imported into ANSYS Design Modeler and the fluid flow domain was constructed using the Design Modeler. Then both the fluid flow domain and the blade were meshed using ANSYS mechanical module. To ensure good results a fine mesh was generated near the walls of the channel so as to capture the velocity variations due to turbulence. Other parts of the blade and fluid flow domain were meshed in such a way that good results could be obtained without being too computationally intensive. The mesh details of the blade and the fluid domain are mentioned as follows:

Number of nodes	351342
Number of elements	330928
Minimum Orthogonal Quality	0.15993327511574
Maximum Orthogonal Quality	0.999999187497499
Average Orthogonal Quality	0.898924645727948
Standard Deviation	0.132925234035889

3.3 Setup

The blade cooling problem was modelled as a Conjugate Heat Transfer (CHT) problem and ANSYS-FLUENT was used to setup and simulate it. The fluid material was selected to be air from ANSYS-FLUENT database. The blade material was taken to be a nickel-superalloy Inconel 718, which has widespread aerospace applications. The material properties of Inconel 718 are listed as below:

Material Name	Thermal Conductivity (k)	Density (ρ)	Specific Heat Capacity (C_p)
Inconel 718	11.4 W/m-K	8190 kg/m ³	435 J/kg-K

3.3.1 Boundary Conditions

The boundary conditions used were as specified in ^[12]. Five different mass transfer rates were used for the channel with ribs. For the smooth channel only one mass flow rate of 0.01 kg/s was used in order to compare with the ribbed channel.

- Mass flow rate(m): 0.01 kg/s, 0.02 kg/s, 0.03 kg/s, 0.04 kg/s, 0.05 kg/s
- Convection Heat Transfer Coefficient(h) at outer surface of blade : 1000 W/m²-K
- Free-stream temperature of the surroundings(T_{free}): 1700 K
- Temperature of the air at the inlet(T_{inlet}): 400 K

3.3.2 Solution Method

Energy equation was turned on and the turbulence was modeled with k-ε model. The wall treatment was done with standard wall functions.

- Scheme: SIMPLEC
- Gradient: Least Square Cell Based
- Pressure: Linear
- Momentum: Power Law
- Turbulent Kinetic Energy(k): Power Law
- Turbulent Viscous Dissipation(ε): Power Law
- Energy: Power Law

4 Results

In order to have a comprehensive understanding of the flow and to compare different flow scenarios, the results of the simulation have been presented in different formats. A number of trend graphs were also drawn to show the variation over the blade volume.

- Isometric views of the temperature contours of the blade for ribbed channel for different values of mass flow rate.
- Temperature contours of the blade at outlet channel for different values of mass flow rate.
- Temperature contours of the fluid flow domain different values of mass flow rate.
- The trend of average Nusselt number of rib surfaces respect to distance from inlet
- The trend of average heat transfer coefficient of rib surfaces with respect to distance from inlet.
- The trend of average skin friction coefficient of rib surfaces respect to distance from inlet.
- The trend of the average temperature of the blade cross-section at intervals of 10 mm was plotted with respect to distance from inlet.

4.1 Temperature Contours of Blades

a. Mass flow rate : 0.01 kg/s

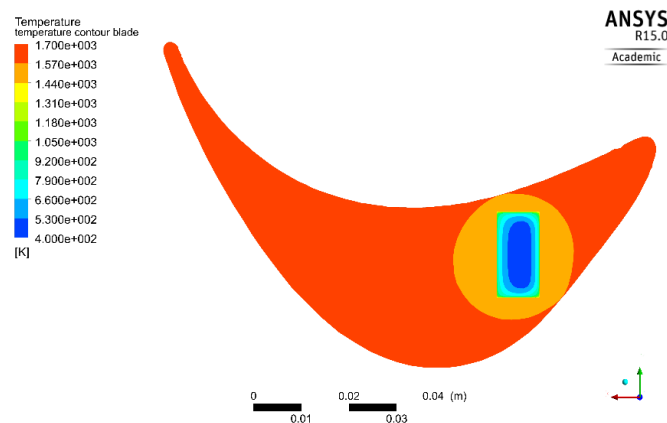

Figure 4.1-1: Temperature contour at outlet of the passage for $m=0.01$ kg/s

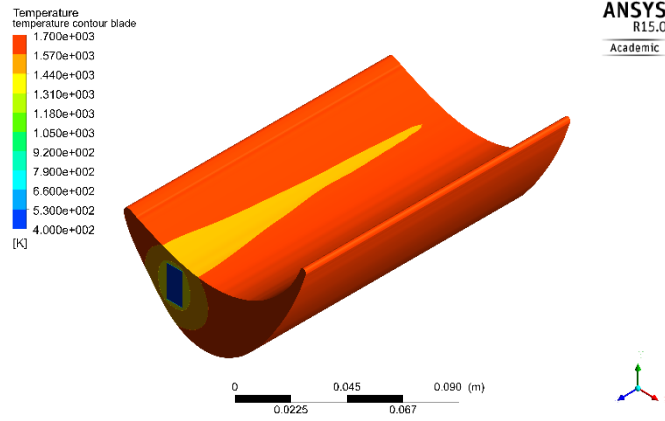

Figure 4.1-2: Temperature contour of the blade body for $m = 0.01 \text{ kg/s}$

b. Mass flow rate: **0.02 kg/s**

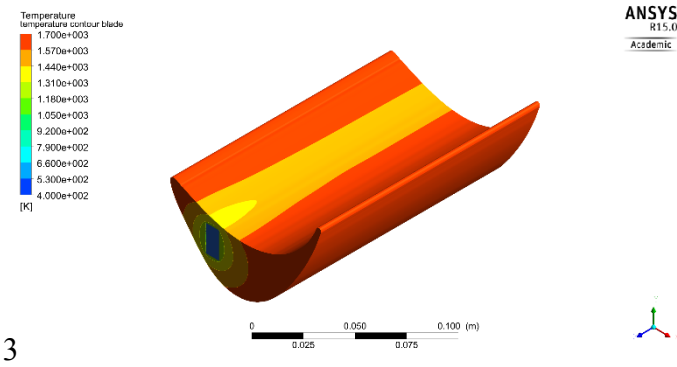

Figure 4.1-3: Temperature contour of the blade body for $m = 0.02 \text{ kg/s}$

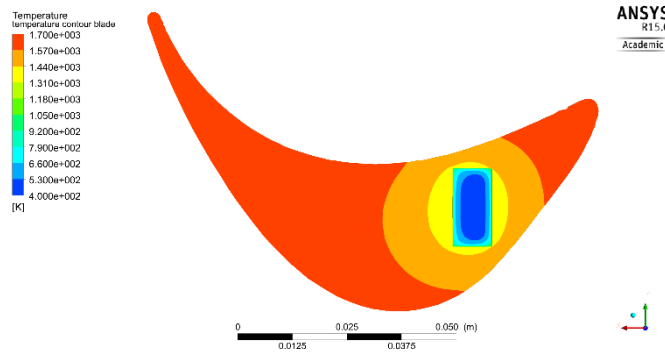

Figure 4.1-4: Temperature contour at the outlet of the passage for $m = 0.02 \text{ kg/s}$

c. Mass flow rate: 0.03 kg/s

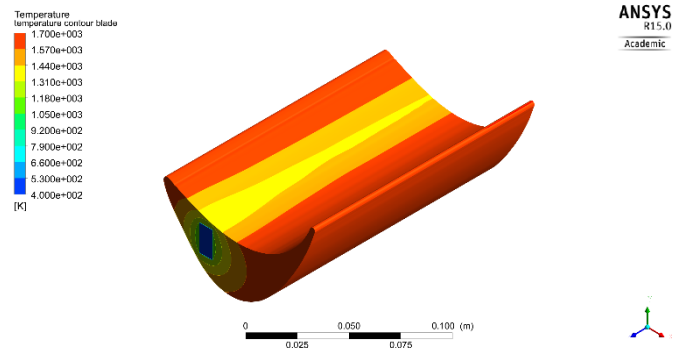

Figure 4.1-5: Temperature contour of the blade body for $m = 0.03$ kg/s

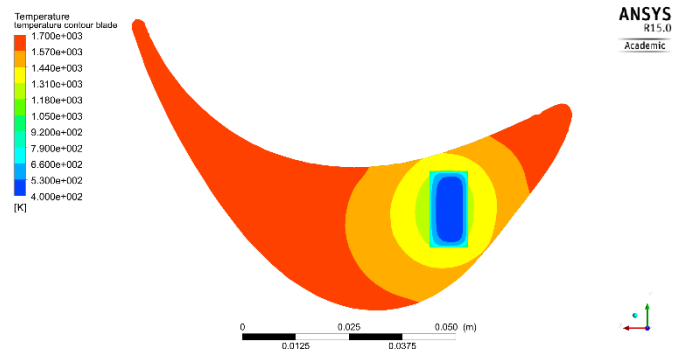

Figure 4.1-6: Temperature contour at outlet of the passage for $m = 0.03$ kg/s

d. Mass flow rate : 0.04 kg/s

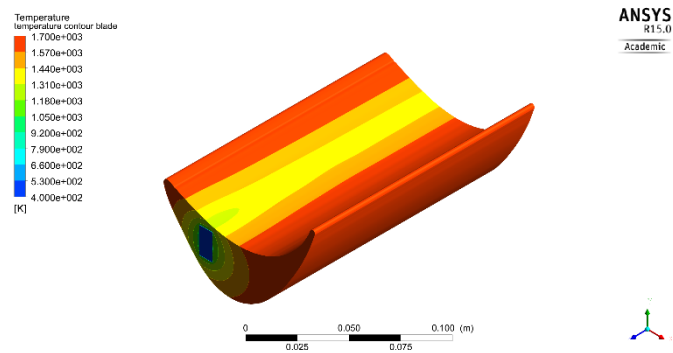

Figure 4.1-7: Temperature contour of the blade body for $m = 0.04$ kg/s

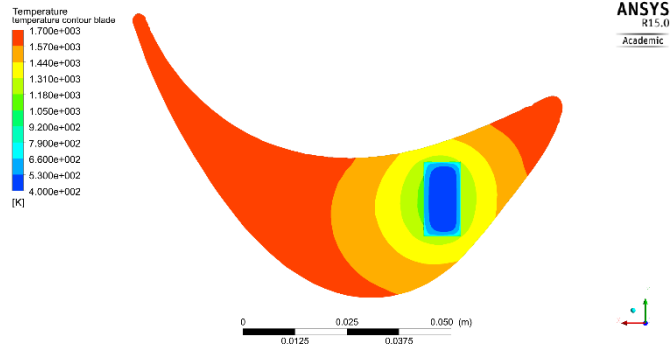
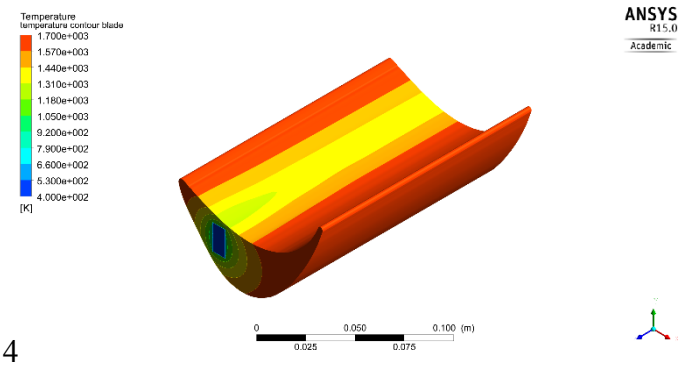

Figure 4.1-8: Temperature contour at outlet of the passage for $m = 0.04 \text{ kg/s}$

e. **Mass flow rate: 0.05 kg/s**



4

Figure 4.1-9: Temperature contour of the blade body for $m = 0.05 \text{ kg/s}$

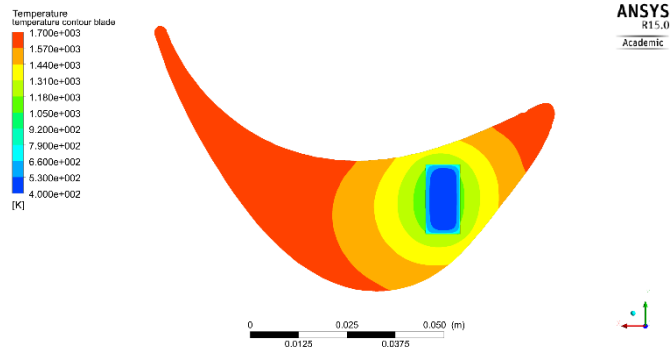

Figure 4.1-10: Temperature contour at outlet of the passage for $m = 0.05 \text{ kg/s}$

4.2 Temperature of Fluid Domain

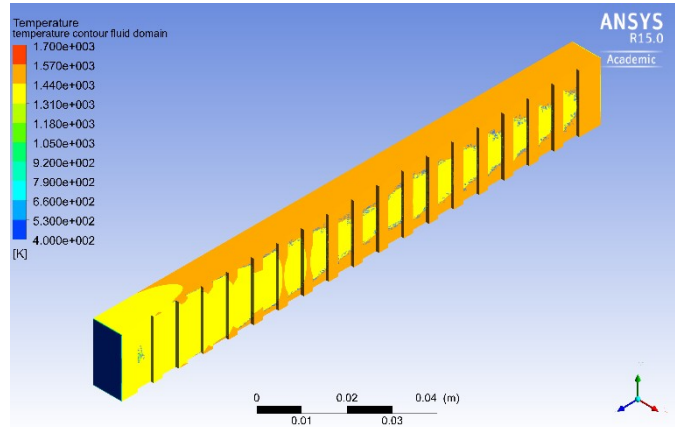

Figure 4.2-1: Temperature contour of the fluid domain for $m = 0.01$ kg/s

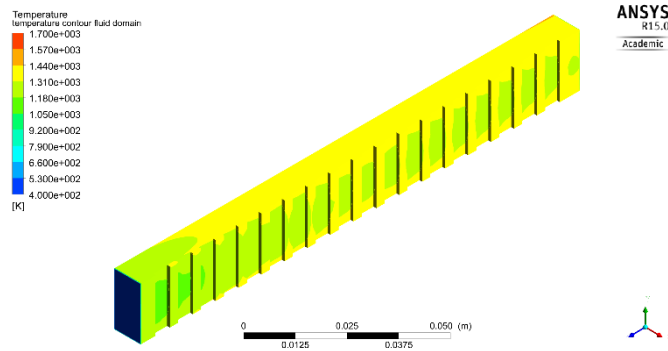

Figure 4.2-2: Temperature contour of the fluid domain for $m = 0.02$ kg/s

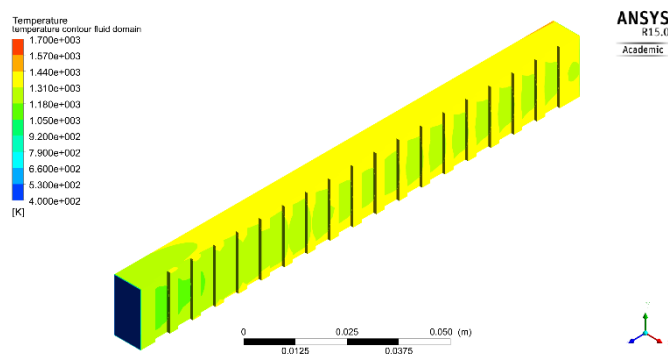

Figure 4.2-3: Temperature contour of the fluid domain for $m = 0.03$ kg/s

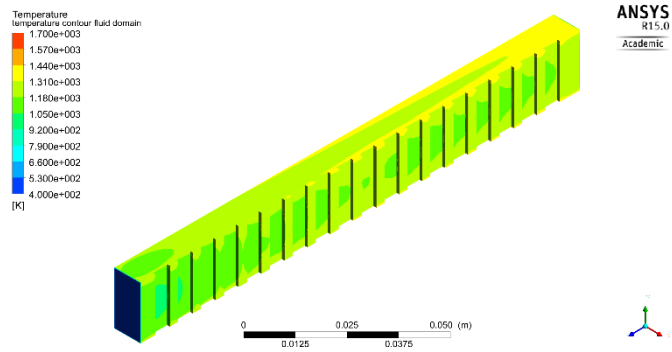

Figure 4.2-4: Temperature contour of the fluid domain for $m = 0.04 \text{ kg/s}$

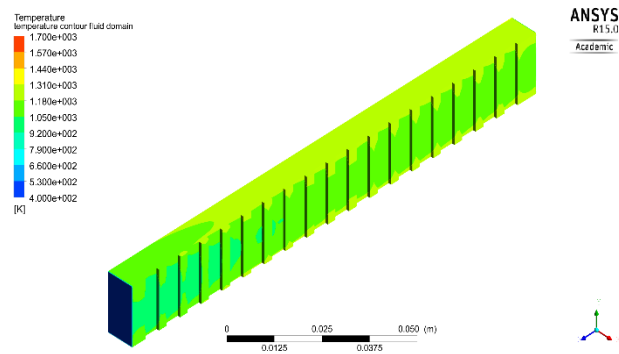

Figure 4.2-5: Temperature contour of the fluid domain for $m = 0.05 \text{ kg/s}$

4.3 Average Rib Temperature Trend

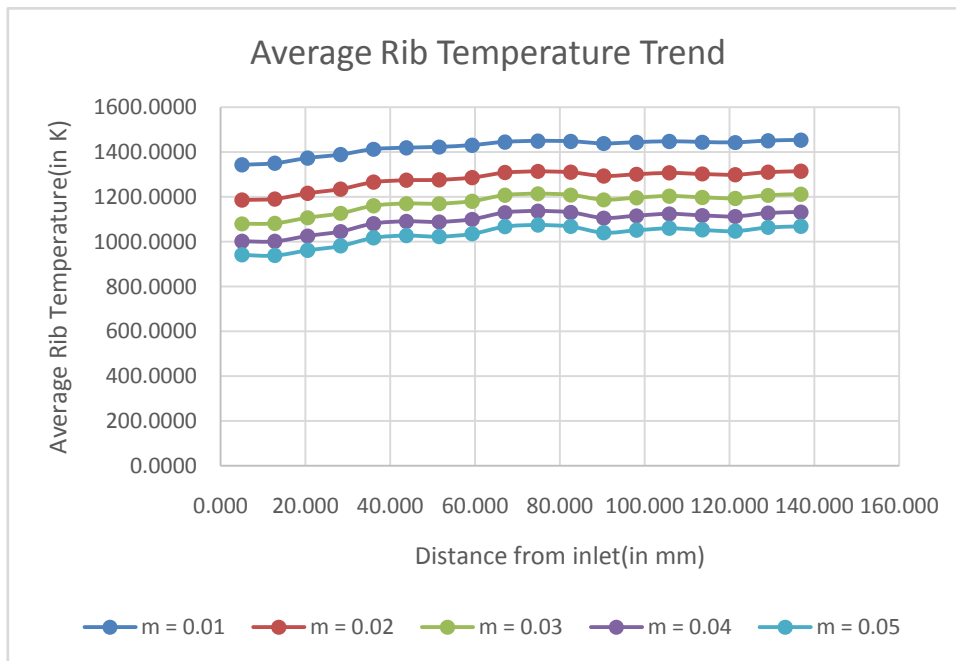

Figure 4.3-1: Variation of average rib temperature, for various mass flow rates

4.4 Average Nusselt Number Trends

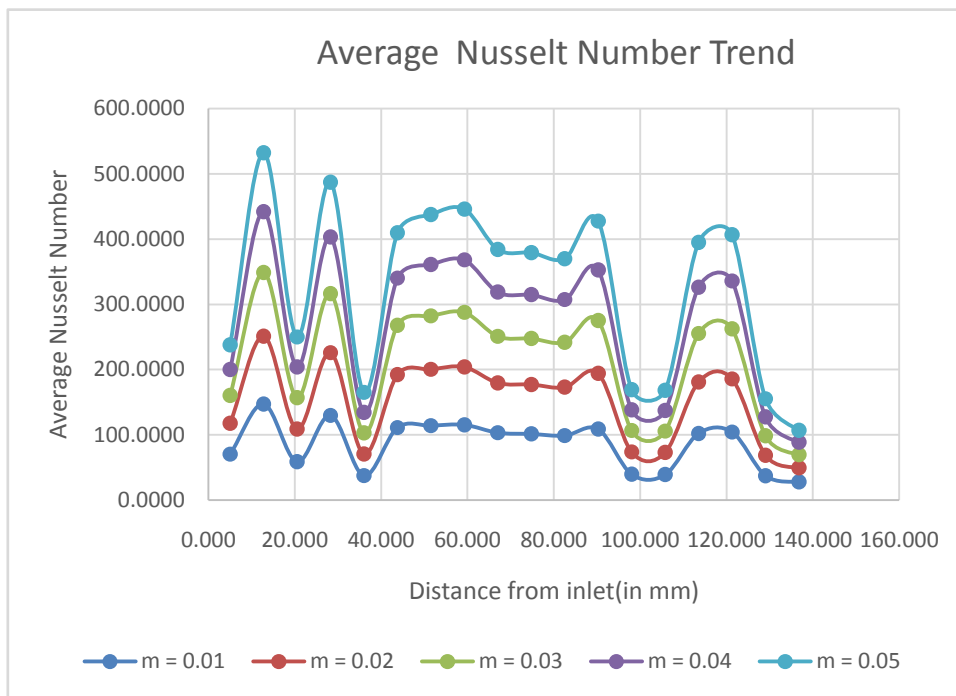

Figure 4.4-1: Variation of Nusselt number, for different mass flow rates

4.5 Average Heat Transfer Coefficient Trends

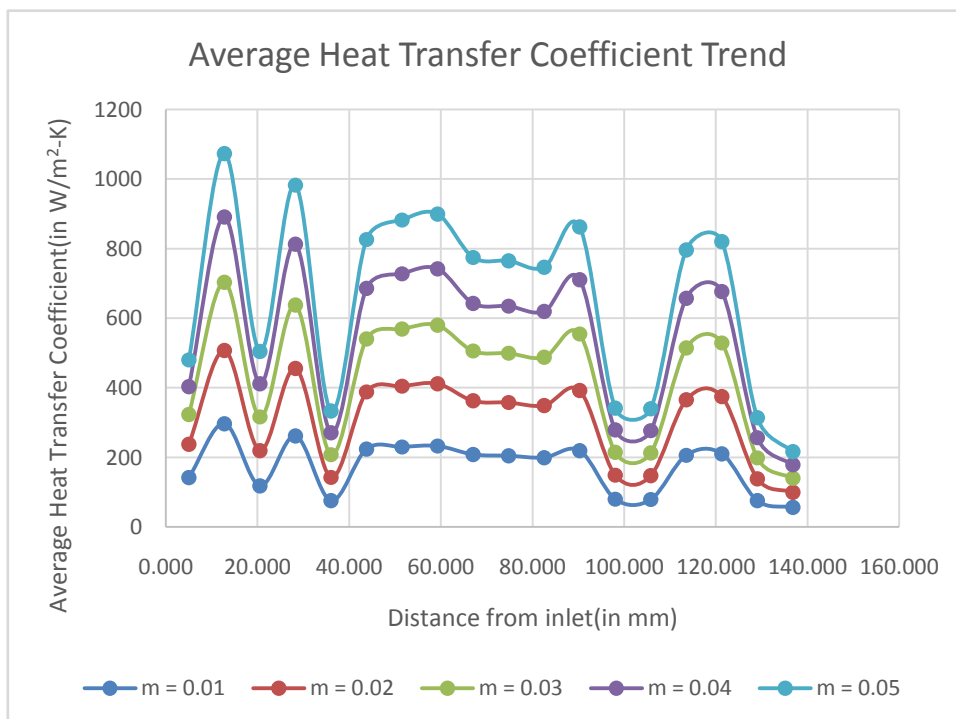

Figure 4.5-1: Variation of Average heat transfer coefficient, for different mass flow rates

4.6 Average Skin Friction Coefficient Trends

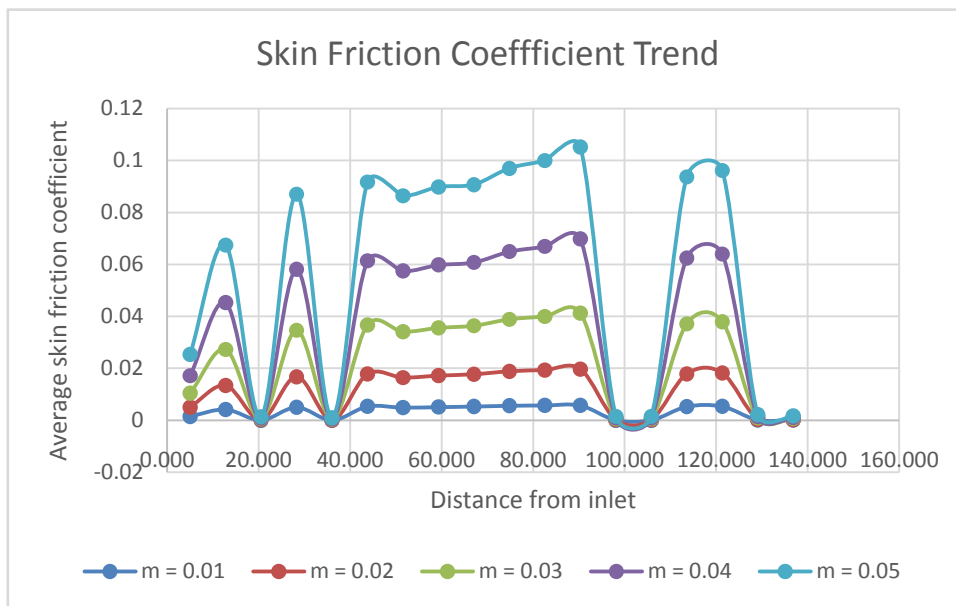

Figure 4.6-1: Variation of average skin friction coefficient, for different mass flow rates

4.7 Average Blade Temperature Trend

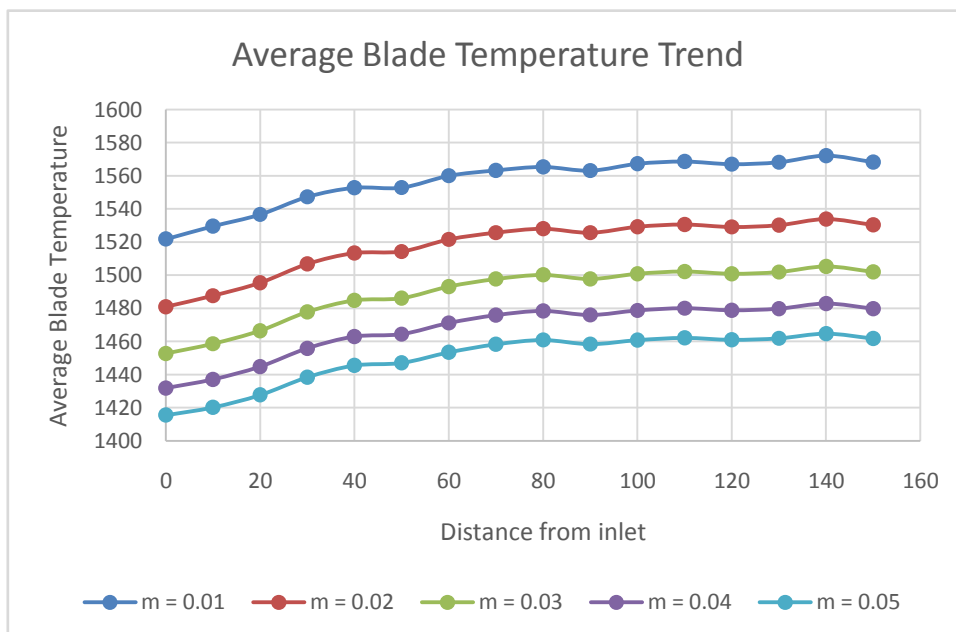

Figure 4.7-1: Variation of average blade temperature, for different mass flow rates.

5 Discussions

5.1 Comparison with Smooth Channel

The simulation was done for both smooth channel and ribbed channel for mass flow rate of 0.01 kg/s. To observe the cooling effects of the air, four points, namely E, F, G, and H were selected on the boundary of the channel at the inlet as shown in Figure 5.1-1. The temperatures of these points were calculated for both smooth channel and ribbed channel. The temperature of the channel with ribs was invariably less than that of the smooth channel. The difference of temperature being less than 10 % in all cases. The mean temperature difference for all the four points was found to be 8.38 %.

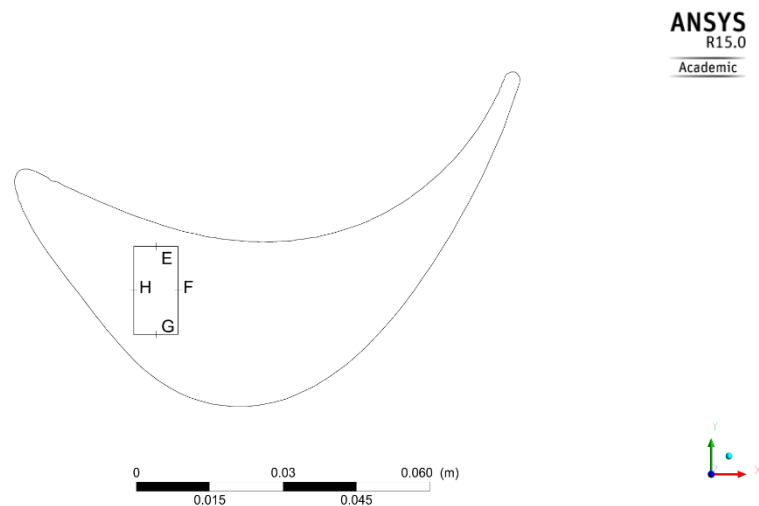

Figure 5.1-1: The four points E, F, G, H selected around the channel inlet

Type of Channel	Point E	Point F	Point G	Point H
Smooth	1571.7	1564.2	1567.7	1572.5
Ribbed	1442.9	1449.5	1447.9	1450.8
Difference	8.92 %	7.9 %	8.3 %	8.4 %

Al-Kayiem et al ^[12] reported a mean temperature difference of 9.5 %. The disparity in results can be attributed to the design of ribs used in the cooling passage. Al-Kayiem et al used

skewed ribs whereas in the present work straight ribs were used. Nonetheless, the fact that the range of temperature difference is same can be used to conclude that the simulation results were valid.

5.2 Comparison for different values of mass flow rate

The cooling effects of air due to increase in mass flow rate were increased. This can be concluded from the following observations:

- As can be seen from Figure 4.4-1 and Figure 4.5-1, average heat transfer coefficient and average Nusselt number of a particular point in the passage increases with increasing mass flow rate
- Moreover as seen in, Figure 4.3-1 and Figure 4.7-1, average rib temperature and average blade temperature of a particular point in the passage increasing mass flow rate.

This is to be expected as increased mass flow through the same cross-section increases velocity and results in more heat transfer due to increased turbulence. However, the skin friction coefficient at a point in the passage also increases with increasing mass flow rate, as seen in Figure 4.6-1. This result in higher frictional losses and thus higher pressure drop and thus more air must be supplied to compensate for the same which adversely affects the thermal efficiency of the engine at the cost of cooling the blade.

6 Conclusion

It can be concluded from this work that the various claims made by different researchers in the past years as far as the cooling effects of ribbed channels are concerned are true and verifiable. The ribbed channels offer a significant enhancement in heat transfer. A further hypothesis was tested in this work, by increasing the mass flow rate in search of an optimal mass flow rate for the flow conditions mentioned. No such optimal mass flow rate could be obtained as the trend was inconclusive. The average heat transfer coefficient and average Nusselt number increased monotonously with increasing mass flow rate, but so did the average skin friction coefficient. Therefore higher mass flow rates cannot be recommended for better cooling without further investigation.

References

1. Gupta, S., Chaube, A., & Verma, P. (2011). Review on Heat Transfer Augmentation Techniques: Application in Gas Turbine Blade Internal cooling. *International Journal on Recent Trends in Engineering & Technology*, 5(4).
2. Han, J. C., "Heat Transfer and Friction in Channels with Two Opposite Rib-Roughened Walls", *ASME Journal of Heat Transfer*, Vol. 106, Nov., pp 774-784, 1984
3. Han, J.C. and Park, J. S., "Developing heat transfer in rectangular channels with rib turbulators." *Int. Journal of Heat and Mass Transfer*, Vol. 31, No. 1, 183-195, 1988.
4. Y.M. Zhang, W.Z. Gu, and J.C. Han, "Heat Transfer and Friction in Rectangular Channels With Ribbed or Ribbed-Grooved Walls," *J. of Heat Transfer*, 116, no.1:58-65, 1994.
5. Liou, T. M., Chang, Y. and Huang, D. W., , "Experimental and Computational Study of Turbulent Flows in a Channel with Two Pairs of Turbulence Promoters in Tandem", *Journal of Turbomachinery*, Vol. 112, pp 302-310, 1990.
6. Taslim, M. E., Li, T. and Kercher, D. M., "Experimental Heat Transfer and Friction in Channels Roughed with Angled, V-Shaped, and Discrete Ribs on Two Opposite Walls", *J. of Turbomachinery*, Vol. 118, pp 20-28, 1996.
7. S. Acharya, V. Eliades and D.E. Nikitopoulos, "Heat Transfer Enhancements in Rotating Two-Pass Coolant Channels with Profiled Ribs: Part 1 – Average Results," *ASME Paper No. 2000-GT-0227*, 2000
8. Johnson, B. V., Wagner, J. H., Steuber, G. D., & Yeh, F. C. (1994). Heat transfer in rotating serpentine passages with selected model orientations for smooth or skewed trip walls. *Journal of turbomachinery*, 116(4), 738-744.
9. Wright, L. M., Fu, W. L., & Han, J. C. (2004, January). Thermal performance of angled, V-shaped, and W-shaped rib turbulators in rotating rectangular cooling channels (AR= 4: 1). In *ASME Turbo Expo 2004: Power for Land, Sea, and Air*(pp. 885-894). American Society of Mechanical Engineers.

10. Alok Chaube, P.K. Sahoo, S.C. Solanki , “Analysis of heat transfer augmentation and flow characteristics due to rib roughness over absorber plate of a solar air heater”, *Int. Journal of Renewable energy*, 31, 317–331, 2006.
11. Kini, Chandrakant R., Satish Shenoy, and N. Yagnesh Sharma. "Thermo-structural analysis of HP stage gas turbine blades having helicoidal cooling ducts." (2014).
12. Al-Kayiem, H. H., Al-Taie, A. K., & Wong, W. T. (2013). Analysis on gas turbine blade cooling by compressed air channels using CFD simulation. *Asian Journal of Scientific Research*, 6(3), 467-477.
13. Girgis et al, HP turbine blade airfoil profile, Patent No. US 7,306,436 B2