

DESIGN OF NON INVASIVE WIRELESS EEG RECORDING SYSTEM

A THESIS SUBMITTED IN PARTIAL FULFILMENT OF THE REQUIREMENTS
FOR THE DEGREE OF

**MASTER OF TECHNOLOGY
IN
ELECTRONICS AND INSTRUMENTATION**

By

**NITISH KUMAR
ROLL NO. – 213EC3221**



DEPARTMENT OF ELECTRONICS AND COMMUNICATION ENGINEERING
NATIONAL INSTITUTE OF TECHNOLOGY
ROURKELA, ODISHA
INDIA
2013 – 2015

DESIGN OF NON INVASIVE WIRELESS EEG RECORDING SYSTEM

A THESIS SUBMITTED IN PARTIAL FULFILMENT OF THE REQUIREMENTS
FOR THE DEGREE OF

**MASTER OF TECHNOLOGY
IN
ELECTRONICS AND INSTRUMENTATION**

By

**NITISH KUMAR
ROLL NO. – 213EC3221**

Under the supervision of

Prof. D. P. ACHARYA



DEPARTMENT OF ELECTRONICS AND COMMUNICATION ENGINEERING
NATIONAL INSTITUTE OF TECHNOLOGY

ROURKELA, ODISHA

INDIA

2013 – 2015



National Institute Of Technology

Rourkela

CERTIFICATE

This is to certify that the thesis entitled, “**Design of Non-Invasive wireless EEG recording system**” submitted to National Institute of technology, Rourkela by **Nitish Kumar**, Roll no. **213EC3221** for the award of Master of Technology degree in **Electronics and Communication Engineering** with specialization in “**Electronics and Instrumentation**” is a bonafide record of research work carried out by him under my supervision and guidance. The candidate has fulfilled all the prescribed requirements.

The thesis, which is based on candidate’s own work, neither this thesis nor any part of it has been submitted for any degree or academic award elsewhere. To the best of my knowledge, the thesis is of standard required for the award of the degree of **Master of Technology** in Electronics & Communication Engineering.

Date:

Prof. D. P. Acharya

Dept. of Electronics and Communication Engg.

National Institute of Technology,

Rourkela – 769008



National Institute of Technology

Rourkela

Dept. of Electronics and Communication Engineering

DECLARATION

I certify that

- (a) The work included in this thesis is authentic and has been done by myself under the general surveillance of my supervisor.
- (b) The work has not been presented to any other institute for any degree or diploma.
- (c) I have proceeded according to the instructions provided by the institute in scripting the thesis.
- (d) Whenever I have practiced materials (datum, theatrical explication and text) from other sources, I have acclaimed them by quoting them in the words of the thesis and giving their specifics in the references.
- (e) Whenever I have credited written materials from other sources, I have kept them covered by quotation marks and acclaimed the sources by mentioning them and giving desired specifics in references.

ACKNOWLEDGEMENT

First and foremost, I place on record, my earnest gratitude to my guide **Prof. D. P. Acharya** who has supported me all the way through my thesis with his co-operation and expert guidance and had been patience whilst letting me the scope to endeavour in my own way. I simply could not hope for a better and friendlier guide.

I am extremely grateful to our Head of the Department **Prof. K. K. Mahapatra** and esteemed faculty members **Prof. U. C. Pati, Prof. T. K. Dan** and **Prof. S.K. Das** for their support and encouragements.

I am very thankful to PHD scholars, especially **Mr. Debasish Nayak** and **Mr. Umakanta Nanda** who always supported me in the successful completion of my thesis work.

I am indebted to my seniors, especially **Sandeep Singh, Sangeeta Sahu** and **Neelima Samal** for buying time off their busy schedules and offering insights to enrich my ideas.

My heartfelt appreciation goes to my friends, **Subhranshu Srivastava** and **Prasann Kovid** for the sleepless nights of working together before the deadlines and my juniors.

Prima facie I would like to thank god for his blessings and my family for their everlasting motivation.

NITISH KUMAR

ROLL NO. – 213EC3221

ABSTRACT

Biomedical signal monitoring systems have drawn great attention now a day by the results yielded from weighty advances in electronics and communications and field of information technologies. As an example EEG (electroencephalogram) is the most popular interface for measuring bio-potential in brain computer interface (BCI) systems which is a prominent topic organising a direct communication link between human brain and a computer. We know that most BCI (brain computer interface) systems are bulky and hard wired EEG experiments which are inconvenient and troublesome for patients to follow their regular routine tasks. So, to overcome this problem we are going to develop a single channel wireless EEG (electroencephalogram) acquisition and recording system which will be more comfortable and convenient to the patients.

The system consists of an EEG signal acquisition and processing units along with the wireless transmission and reception units. The former (analogue processing unit) includes electrodes, pre-amplifiers, filters and gain amplifiers while the later (digital processing unit) includes ADC (analogue to digital converter) and microcontroller which are used to convert the analogue EEG signals into digital signals and fulfil the digital filtering. The transmission and reception units include a Bluetooth communication module which sends the digital signals to the PC (personal computer) to be displayed over the GUI (graphical user interface). Thus the patient's EEG signal could be observed and stored without any bulky wired environment due to which the distortion caused by the long distance transmission could be reduced significantly. The key performances are:

- a) Long range communications (50 metres)
- b) ADC sampling rate is high (400 samples/sec)
- c) Low power consumption.
- d) Portable and
- e) Battery operated.

Medical research applications based on wireless EEG acquisition system can be explored such as brain controlled games and diagnosis of diseases.

CONTENTS

Acknowledgement	(iii)
Abstract	(iv)
List of figures	(vi - vii)
Abbreviations used	(viii)
Chapter 1 – Introduction	(1 - 9)
1.1 Overview	(2 - 7)
1.2 Literature review	(8)
1.3 Thesis description	(9)
Chapter 2 –EEG recording method	(10 - 12)
2.1 10 – 20 electrode placement system	(11 - 12)
2.2 Electroencephalography	(12)
Chapter 3 – Analogue frontal neb for EEG signal	(13 - 38)
3.1 System overview	(14 - 18)
3.2 Components description	(18)
3.2.1 Instrumentation amplifier	(18 - 20)
3.2.2 Low pass filter	(20 - 22)
3.2.3 High pass filter	(23 - 24)
3.2.4 Notch filter	(24 - 27)
3.2.5 Analogue to digital converter	(27 - 29)
3.2.6 8051 Microcontroller board	(29 - 32)
3.2.7 Wireless communication module	(33 - 34)
Chapter 4 – Developing graphical user interface	(35 - 37)
Chapter 5 - Result and conclusion	(38 - 40)
5.1 Result	(38)
5.2 Conclusion	(40)
References	(41 - 42)

LIST OF FIGURES

Fig. 1 Block diagram of EEG recording system	(5)
Fig. 2 10 – 20 electrode placement system	(11)
Fig. 3 Transmitter circuit	(15)
Fig. 4 Schematic of analog circuit	(16)
Fig. 5 PCB layout of analog circuit	(17)
Fig. 6 The profound amplifiers and filters design	(18)
Fig. 7 Internal circuit of instrumentation amplifier	(19)
Fig. 8 Connection diagram of AD8221	(19)
Fig. 9 AD8221 plot of CMRR vs frequency at gain = 1	(20)
Fig. 10 Second order low pass filter	(21)
Fig. 11 Response of low pass Butterworth filter with varying orders	(22)
Fig. 12 Second order high pass filter	(23)
Fig. 13 Response of high pass filter	(24)
Fig. 14 Schematic of notch filter	(26)
Fig. 15 Response of first order notch filter	(26)
Fig. 16 Response of second order notch filter	(27)
Fig. 17 Analog to digital converter (ADC0804)	(29)
Fig. 18 8051 microcontroller	(30)
Fig. 19 8051 internal schematics	(30)
Fig. 20 8051 microcontroller board	(31)
Fig. 21 ADC and LCD interfacing with microcontroller	(32)
Fig. 22 Simplified block diagram of ZL70321	(38)
Fig. 23 Block diagram for signal acquisition	(40)
Fig. 24 Front panel numeric indicators	(41)
Fig. 25 Front panel Waveform graph	(41)
Fig. 26 Digital circuit output	(43)
Fig. 27 EEG waveform	(43)

ABBREVIATIONS USED

EEG	Electroencephalography
SNR	Signal to noise ratio
PC	Personal computer
ADC	Analogue to digital converter
PCB	Printed circuit board
NIRS	Near infrared spectrometry
icEEG	Intra cerebral EEG
NLEO	Non linear energy operator
AR	Auto regressive
LCD	Liquid crystal display
Lab VIEW	Laboratory virtual instrumentation engineering workbench
CMRR	Common mode rejection ratio
LED	Light emitting diode
MICS	Medical implant communication service
CRC	Cyclic redundancy check
MAC	Media access control
BER	Bit error rate
LGA	Land grid array
GUI	Graphical user interface
PQFP	Plastic quad flat package
TQFP	Thin quad flat package
PLCC	Plastic leaded chip carrier

CHAPTER1

INTRODUCTION

1.1 Overview:

Richard Caton was the first man in late 1800s who found the presence of bio-potentials on the covering of human brain. Since then EEG (electroencephalography) has been used for analysing different neural environment. EEG is the measurement of electrical activity of the neurons inside brain. We know that EEG recording in man is widespread, not expensive and non-invasive technologies suitable for long term monitoring with sufficient resolution, the EEG recording systems play an significant role in brain studying, it's diagnosis and sorting out the diseases such as abnormal behaviour, syncope, migraine variants, epilepsy, catatonia, sleeping disorder and patients in coma etc. with the help of recorded data.

EEG recording methods can be classified into two categories:

- a) Invasive method – In this method electrodes are placed over the scalp.
- b) Non-Invasive method – This method requires electrodes placement under the scalp. This method is mostly used in surgical operations.

There is an internationally recognised method developed for the localisation of electrodes on the scalp based on the distances between the electrodes in order to conceal the important points which we are going to use for the measurement.

The Invasive method of electrode placement is far more complicated as compared to Non-Invasive method. This method requires the head should be kept absolutely still when the electrodes are plunged into brain, since any movement can cause damage of neurons inside brain by electrodes. The patient's head should be placed inside a custom designed casing which is pinched to the skull so that the head movement could be reduced. Following this the neurosurgeons drill some holes on skull precisely in order to plunge electrodes and read the data out.

The only disadvantage of Invasive EEG recording method over non-invasive method is it takes at least one or more months for complete recovery of the patient from surgery. This method has some advantages:

- a) It is highly accurate and sensitive.
- b) SNR (signal to noise ratio) of this method is approximately 10 to 100 times higher than non-invasive method.

The use of Invasive method has been reduced recently. The surgeon figures out attentively whether it is necessary to use invasive method or it can be done using non-invasive method.

The invasive method of EEG measurement is applied only when the doctors can't identify the problem using Non-invasive method. In other words we can say that the Non-invasive method has numerous applications and it is more comfortable to the patient. Non-invasive recording method doesn't require the plunge of electrodes into patient's brain since the EEG signal can be recorded by connecting the electrodes into the connectors fixed in the custom designed cap on the scalp only. Sometimes a conductive paste is used to establish an electrical connection between scalp and electrodes in order to improve the SNR.

EEG recording systems currently have EEG recorder based on PC (personal computer) had to transfer data through the I/O ports with the medical instruments. The existing EEG machine uses a bulky wired environment which consists of RS-232 standard interface to transmit the obtained EEG signal. The above system was uncomfortable and inconvenient to patients to perform their daily life tasks in because of the presence of bulky wired transmission lines between display device and the neuronal measurement activity device. Whenever EEG acquisition device is used to transfer signals to a portable device such as PC (personal computer) the bulky wired transmission lines always caused inconvenience in monitoring. Now, if the recent advantages in wireless technology such as Bluetooth technology is used the application of EEG recording machine can be spread more widely. In the conventional EEG system the computer faces problems in reading the program, analysing it and displaying the recorded EEG signals. So, if the recorded data can be treated properly and completely then the reliability of the EEG recording system will be improved significantly.

The purpose of study of the conventional EEG system is to improve its architecture. So in our work, a single channel EEG recording system is being proposed. The Bluetooth transceiver is used create a wireless transmission/reception medium between the acquisition circuit and the computer interface to dwindle the bulkiness of the system. This wireless communication technique will reduce signal distortion and also enhance the quality of EEG signals. 8051 microcontroller board is used as core processor for the digital circuitry since it has better energy saving capability and can be developed easily. Using this system the brain activities such as epilepsy, abnormal behaviour and sleeping disorder could be observed. Providing a better EEG reading program on PC requires an effective and simple classification process of EEG signal from noise.

During long term recording of EEG signals the movement of patient always creates disturbance in observation. So, to obtain correct EEG data we must develop a stepwise algorithm to for signal processing. The above EEG recording system consists of six building blocks:

1. Instrumentation amplifier
2. Band pass filter and amplifier.
3. A/D converter.
4. 8051 microcontroller board.
5. Bluetooth module and
6. PC (Personal computer).

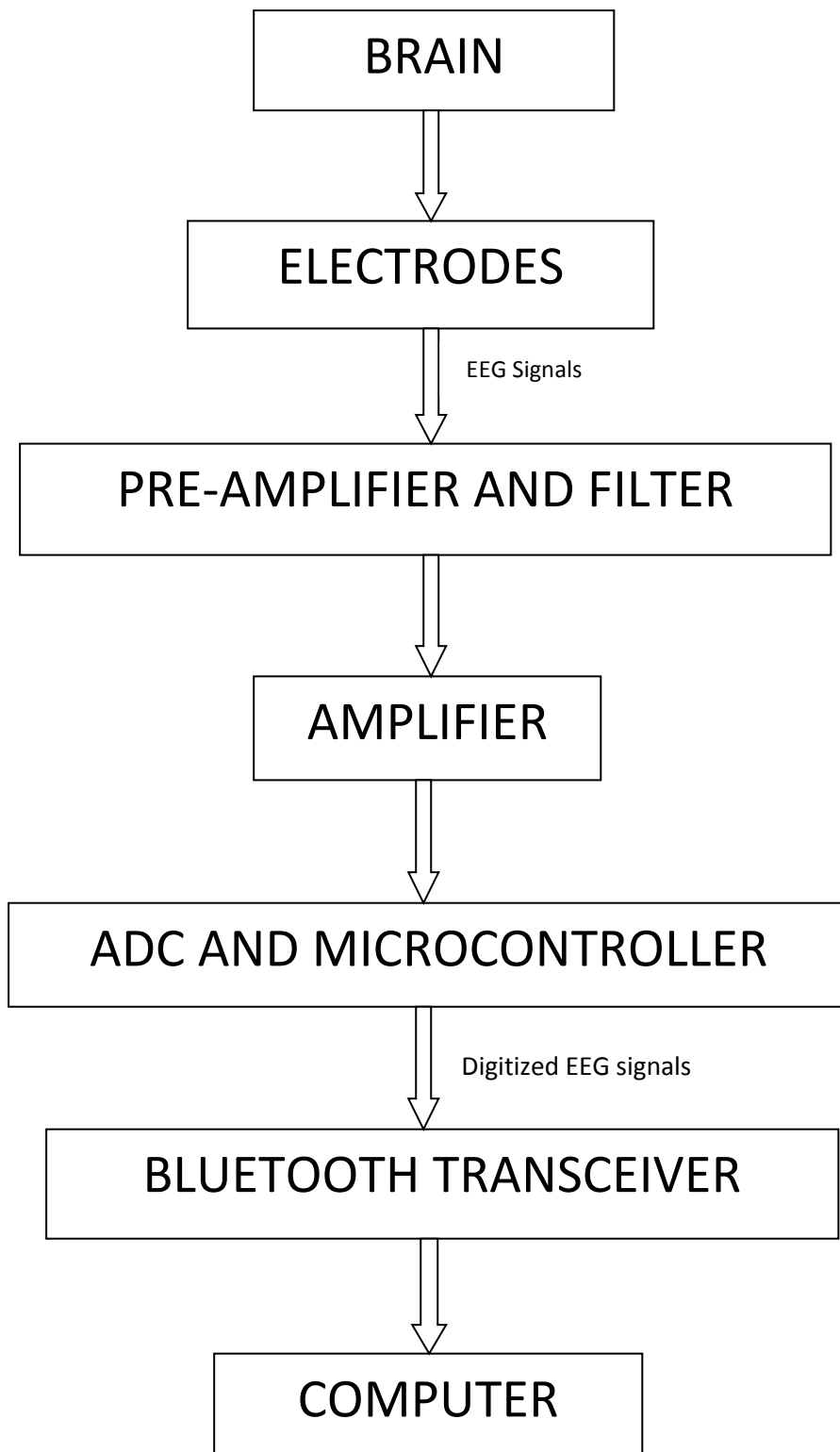

Fig. 1- Block diagram of EEG recording system

Initially the Non-invasive active EEG electrodes used here to acquire the analogue signals from brain which are then amplified and filtered by dissimilar layers of amplifiers and filters. Here we are using instrumentation amplifier (AD8221BR) to provide a higher gain to the EEG signal so that it could be further processed. These amplified signals then filtered and again amplified in order to reduce the noise which then gets digitized by the ADC0804 (analogue to digital converter) assembled in the microcontroller board. Here we have introduced a notch filter (a kind of narrow band stop filter) to prevent the system from power line interferences with 60 Hz frequency that includes higher order harmonics. These digitized signals are then transmitted and received by the transmission and the reception units respectively with the help of Bluetooth module which are then displayed on the PC. The data stored in PC can be used for further use.

Realistic EEG acquisition commonly includes abundant amount of data. For example an EEG recording system with 32 channels and sampling frequency 256 channels per second takes at least an hour to complete the experiment.

An EEG recording and analysis system will receive the transmitted EEG signal along serial port connected to the PC (personal computer). All the involved hardware components in the acquisition part will work together to ensure that the EEG signal can be correctly sampled and transmitted to the outlying computer.

In this thesis, a single channel EEG recording system for monitoring the data acquisition, wireless data transmission and real time signal analysis is presented. This system includes Non-invasive active EEG electrodes, band pass and band stop filters, instrumentation amplifiers, analogue to digital converters, microcontroller board, Bluetooth module, serial port transmission modules, graphical user interface and PCB (printed circuit board) layout for the circuit.

The system provides platform for connecting electrodes over the scalp and performs some EEG scrutiny algorithms on computer. The prototype for single channel EEG is designed and manufactured. The attainments of this proposed system are:

- a) Communication range – 10 metres.
- b) Wireless data transference rate – 82 kbps.
- c) Data acquisition rate – 400 samples per second.
- d) 60 Hz power line interference reduction.
- e) Power consumption is less than 40mw.

1.2 Literature Review:

Xun Chen, Z. Jane Wang – Bioinformatics and biomedical engineering, University of British Columbia, Canada 2011, “Design and implementation of wearable wireless EEG recording system”. In this paper they had designed a single channel EEG recording system based on java software platform and the Zigbee module as the wireless unit.

M. Sawan, M. T. Salam, Jerome Le Lan, Amal Kassab, Sebastien Gelinas, Phets amone Vannasing, Frederic Lesage, Maryse Lassonde and Dang K. Nguyen – IEEE transactions on Biomedical circuits and systems, Vol. 7, No. 2, April 2013, “ Wireless recording systems: from Non invasive EEG-NIRS to Invasive EEG devices”. In this paper they had presented a wireless wearable EEG system for recording and monitoring. This system had been used for measurement of (a) Near Infrared Spectrometry (NIRS) and scalp EEG for Non invasive monitoring and (b) Invasive monitoring for icEEG (Intra Cerebral EEG) using Bluetooth and radio links.

Robert Lin, Ren-Guey Lee, Chwan-Lu Tseng, Yan-Fa Wu and Joe-Air Jiang – Bio Industrial mechatronics engineering, National Taiwan University, December 2006, Vol. 18: 276 – 283, “ Design and implementation of wireless EEG recording system and study of EEG clustering method”. In this paper they had designed a Wireless EEG acquisition and recording system composed of preamplifiers, filters and gain amplifiers. Wireless communication had been established by means of Bluetooth module. A classification method comprising of nonlinear energy operator (NLEO), auto-regressive (AR) model and bisecting k-means algorithm is used for dividing the EEG signals into many small segments depending upon their corresponding amplitude and frequency.

1.3 Thesis description:

This “Design of wireless Non – Invasive EEG recording system” final thesis includes five chapters.

Chapter 1 includes introduction to the system, it’s overview, how to design the system and literature reviews.

Chapter 2 includes the method used for EEG recording and details of EEG (Electroencephalography).

Chapter 3 includes front end analogue system design, system overview, detailed description of components, coding the ADC and LCD and PCB layout of analogue system.

Chapter 4 includes design of graphical user interface on Lab VIEW platform.

Chapter 6 includes results and conclusions.

CHAPTER 2

EEG RECORDING METHOD

2.1 10 – 20 Electrode placement system:

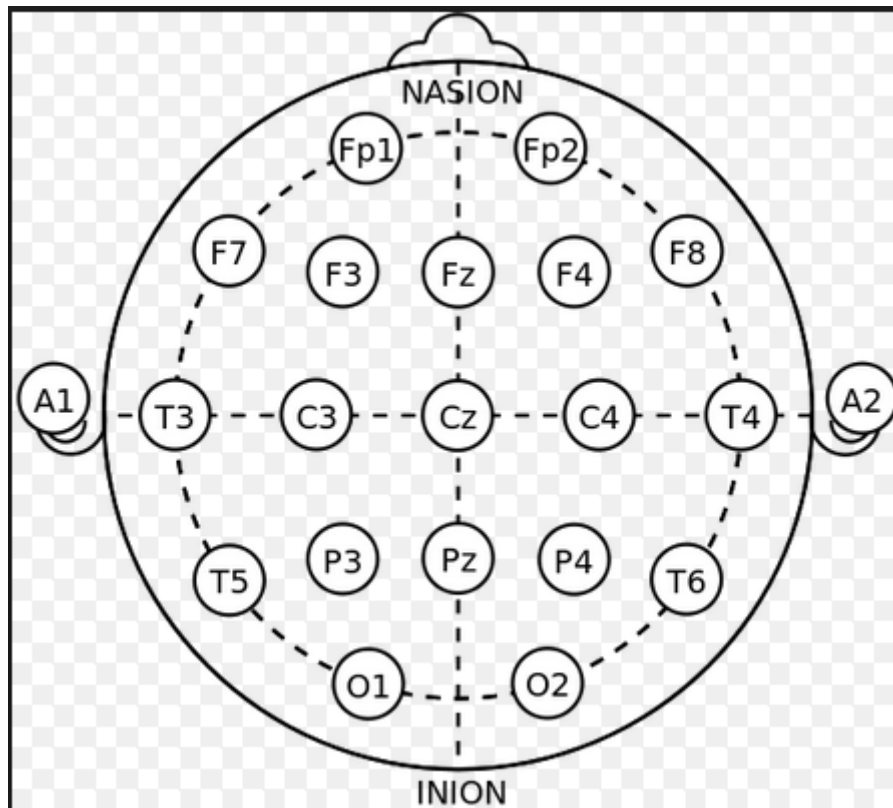

Fig.2- 10 – 20 electrode placement system.

The above is the internationally admitted arrangement for the description of placement electrodes on the scalp for EEG recording. This system describes the relation between location and the area of cortex under electrode. The numbers 10 and 20 indicate the distance between abutting electrodes which are placed either 10 or 20 percent of the entire distance from right to left or front to back.

In the above diagram the alphabets F, O, P, T defines the respective frontal, occipital, parietal and temporal lobes. Here C stands for central but it doesn't indicate any lobe. Z stands for zero to the electrode located on midline. Even numbers (2, 4, 6, 8) indicate the electrodes placed on the right half of scalp whereas odd numbers (1, 3, 5, 7) indicate electrodes on left half of scalp. The letters F_p, A, P_g refer to frontal polar, earlobe and nasopharyngeal areas respectively.

There are two corporal points marked which are important for the positioning of electrodes. They are nasion and inion. Nasion is the area compressed betwixt eyes above bridge of nose whereas inion is the bottommost portion of skull from back of head.

2.2 EEG (electroencephalography):

Basically EEG is the measurement of electrical actions of neurons inside brain as a result of voltage fluctuation due to ionic current flow in neurons. Depending upon the frequency ranges EEG signal is classified as:

- (a) Delta– Frequency range up to 4Hz. These waves are slow and have high amplitudes. These are found generally in adults during slow wave sleep.
- (b) Theta – Frequency ranging from 4 – 7Hz. These waves are generally originate in young children in relaxed, meditative states.
- (c) Alpha - Frequency range from 8 to 15Hz. These waves are higher in amplitude and found in right-left sides of head. These waves are seen during closing and opening of eyes i.e. relaxed state.
- (d) Beta – Frequency range from 16 – 31Hz. These are low amplitude waves and are found in front and back positions of head. These waves arise in active, busy etc. States.
- (e) Gamma – Frequency range is above 32Hz. These waves arise due to short term memory matching of recognized objects.

CHAPTER 3

ANALOG FRONTAL NEB FOR EEG SIGNAL

3.1 System Overview:

An analogue frontal end circuitry for single channel EEG signal recording commonly includes:

- a) Preamplifier, filter and amplifier circuit.
- b) Analogue to digital converter and microcontroller.
- c) Wireless transmitter.

The analogue circuitry mainly include DC filter and amplifier circuit: to filter out the DC signal in order to keep it in a predefined range (0.1 – 70Hz) and to prevent the circuit from high frequency noise signals resulting from power line interferences (60Hz). As we know that EEG signals lie in micro volts range which is very less in amplitude so in order to make it process able further we need to amplify it. Here we are using two amplifiers: an instrumentation amplifier which provides 1000 gain and a non-inverting differential amplifier which provides 10 gains, since the ADC needs minimum 19.5mv when connected in eight bit mode. Digital circuit consists of analogue to digital converter, microcontroller (8051) and LCD (liquid crystal display). The purposed analogue EEG acquisition circuit is a modified version of the conventional design. From the figure drawn below the detailed description of each and every component with respective schematic will be discussed in further sections in detail.

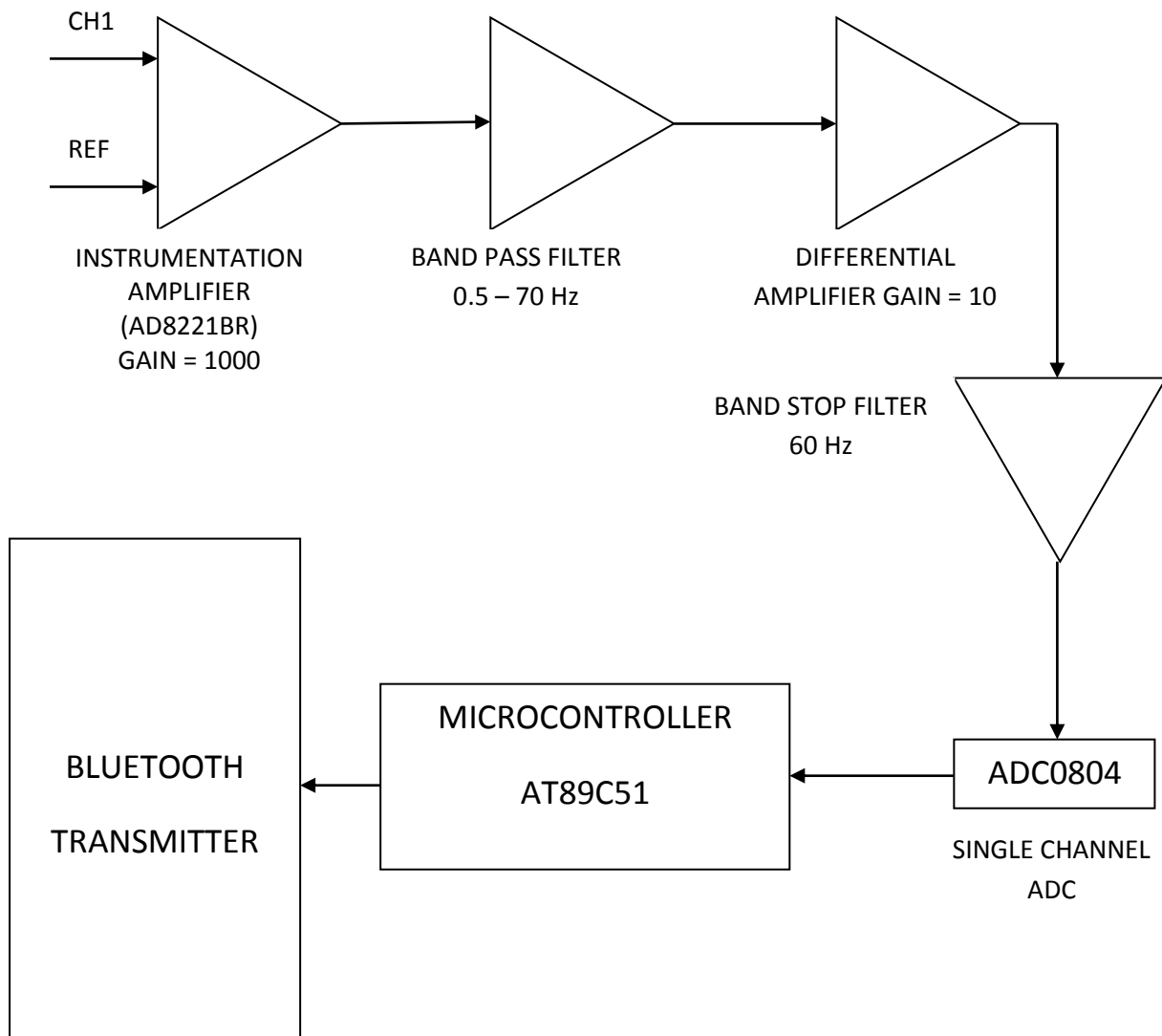

Fig. 3 – Transmitter circuit

The above is the schematic diagram of transmitter section. This circuit includes analogue as well as digital circuit components. In the figure below we are going to discuss in detail about the analogue circuit only consisting of amplifiers and filters, their gains, their bandwidths and why they are used.

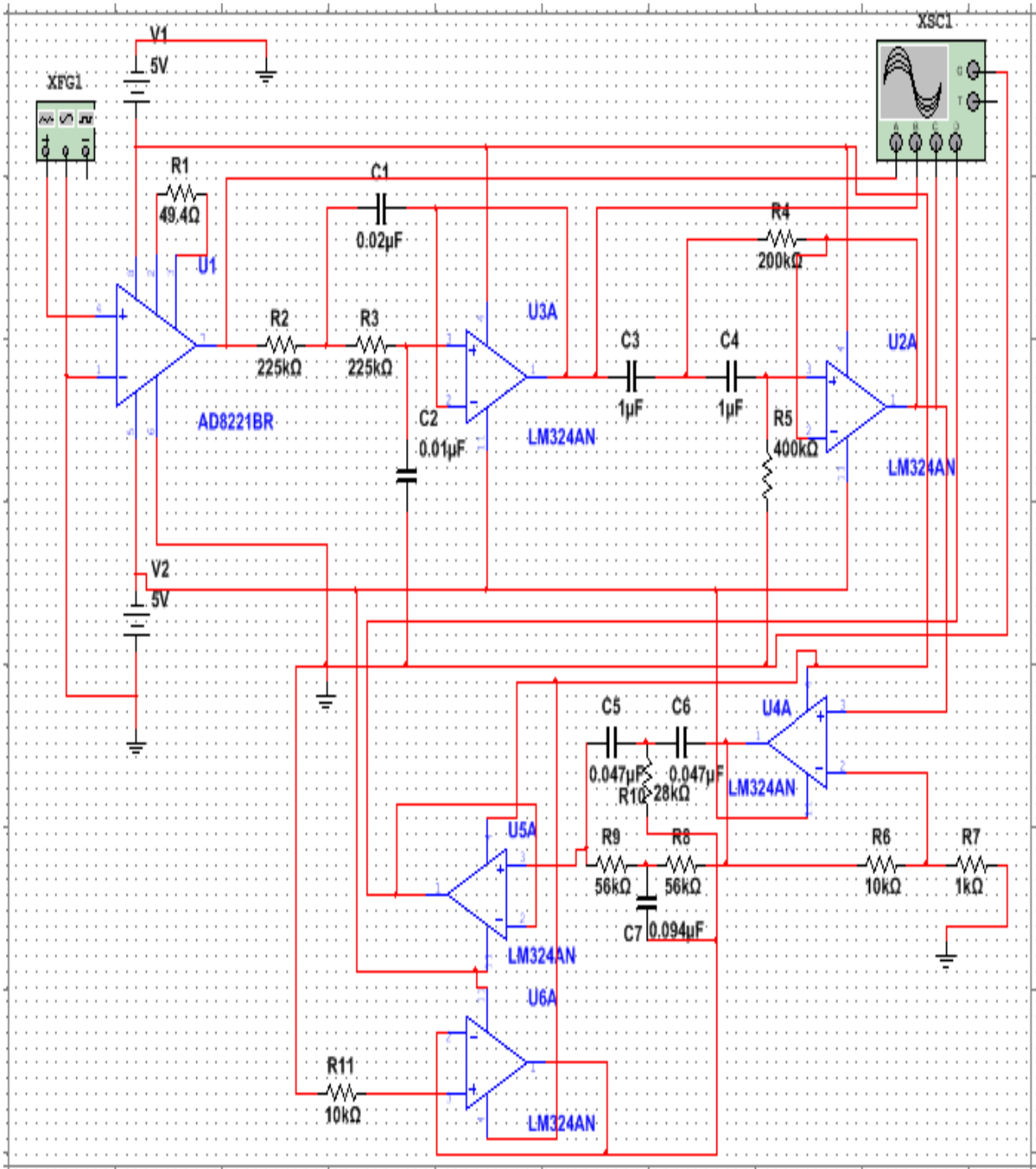

Fig. 4 – Schematic of analogue circuit

RESISTORS(K Ω)	CAPACITORS(μ F)
R1 = 0.0494	C1 = 0.02
R2 = 225	C2 = 0.01
R3 = 225	C3 = 1
R4 = 200	C4 = 1
R5 = 400	C5 = 0.047
R6 = 10	C6 = 0.047
R7 = 1	C7 = 0.094
R8 = 56	
R9 = 56	
R10 = 28	
R11 = 10	

Table 1 – resistances and capacitances values

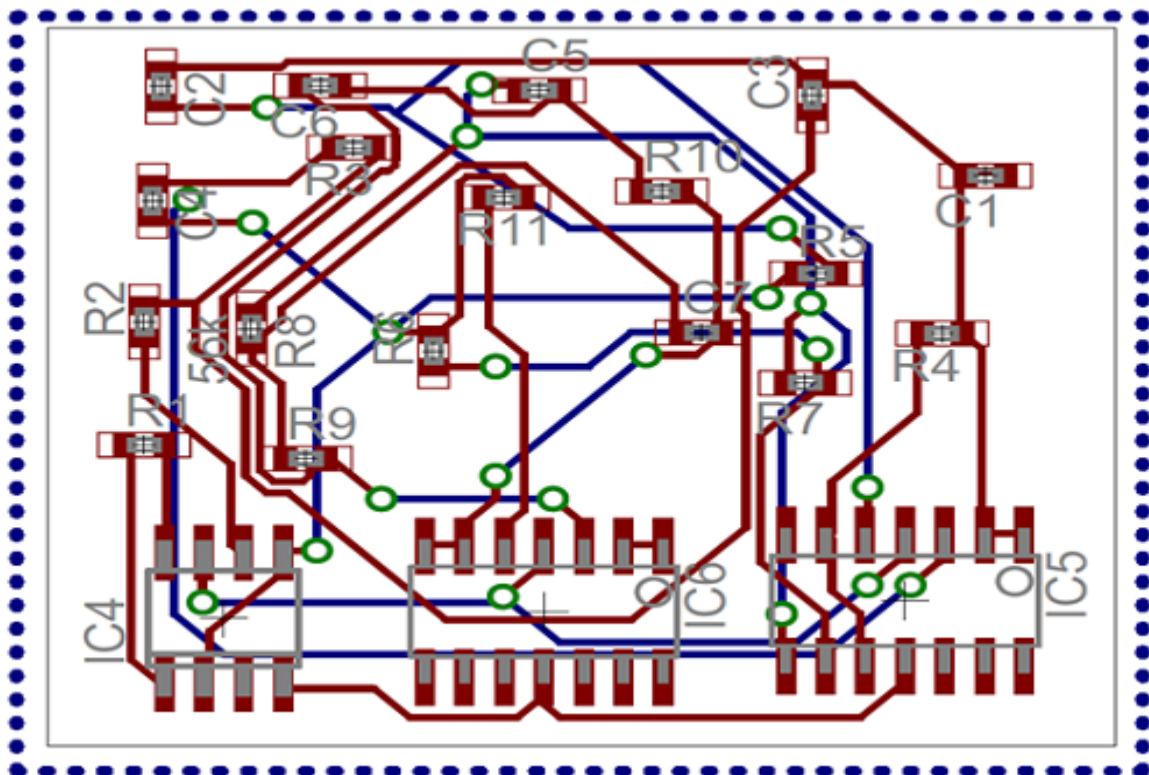

Fig. 5 – PCB layout of analogue circuit.

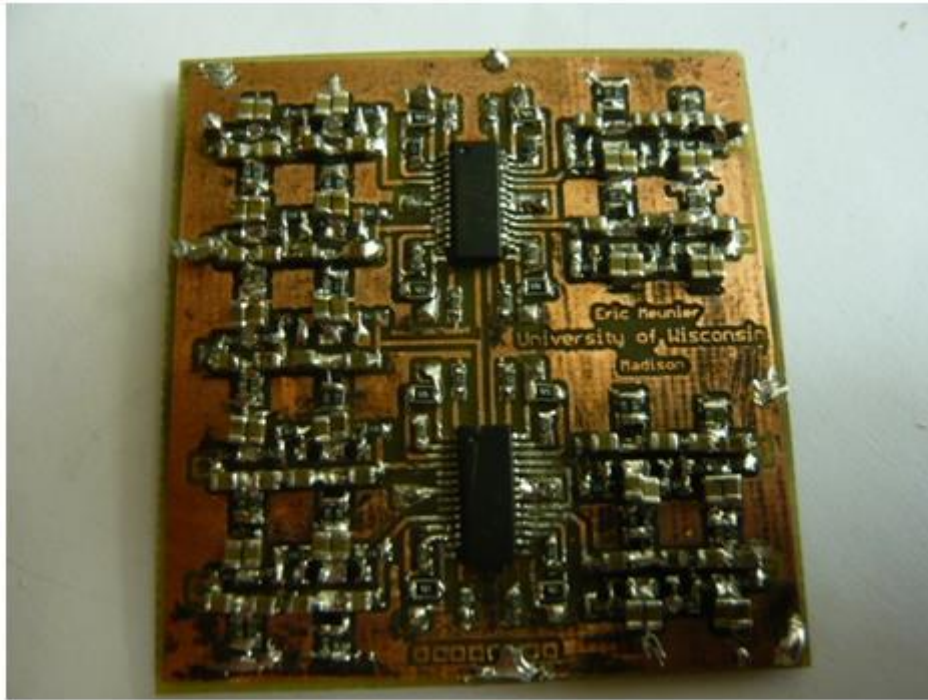

Fig. 6 – The propound filters and amplifiers design.

3.2 Components Description:

3.2.1 Instrumentation Amplifier:

The instrumentation amplifier is a type of differential amplifier that is suited up with three buffer amplifiers which remove the necessity of impedance matching in order to make the amplifier suitable for use in calculation. Its advantages include low noise, high gain (open loop), high input impedance, high CMRR (common mode rejection ratio), low DC offset etc. It has great accuracy and stability as well.

EEG signals are in the range of 10 to 100 micro volts when recorded from non-invasive electrodes while around 10 to 20 milli volts when recorded from invasive electrodes. So an instrumentation amplifier evolves into a best choice for the amplification of EEG signal. Generally a 60 to 100dB of CMRR and a voltage gain of around 1000 to 10000 is required for the amplification to make it up to a level of the range of analogue to digital converter.

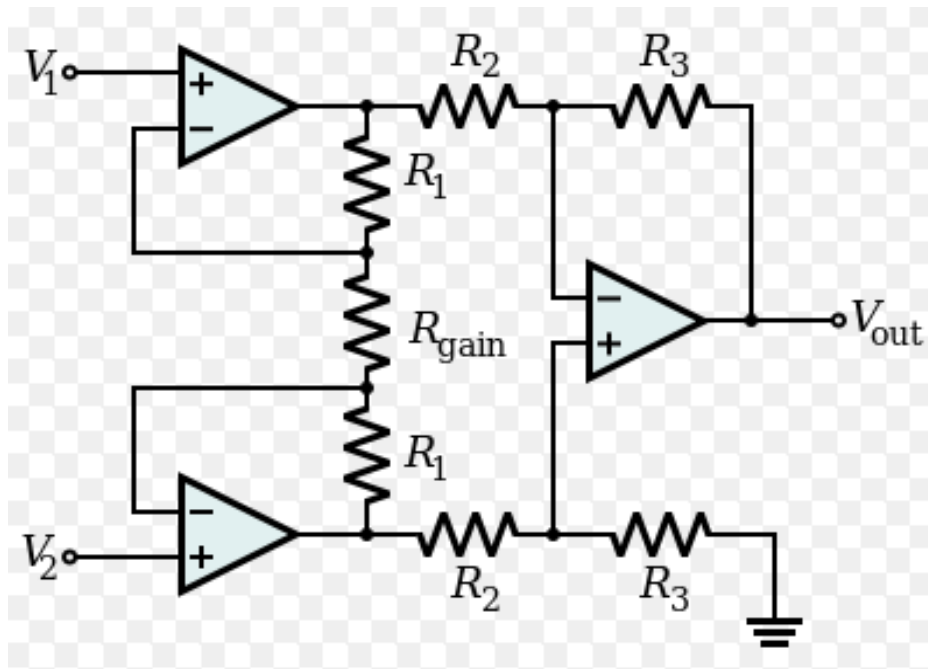

Fig.7 – Internal circuit of instrumentation amplifier.

Here gain G is $\frac{V_{out}}{V_d} = \left(1 + \frac{2R_1}{R_g}\right) \frac{R_3}{R_2}$.

The AD8221BR instrumentation amplifier is a good choice to satisfy the requirements. It has a programmable gain range of 1 to 1000 which can be set with an external resistor, minimum 80dB CMRR and is available in MSOP and SOIC package. The figure below is the connection diagram of AD8221BR. Here gain $G = (1 + 49.4K\Omega / R_g)$

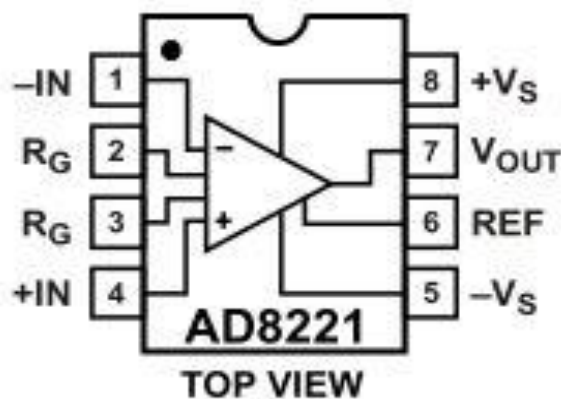

Fig. 8 – Connection diagram

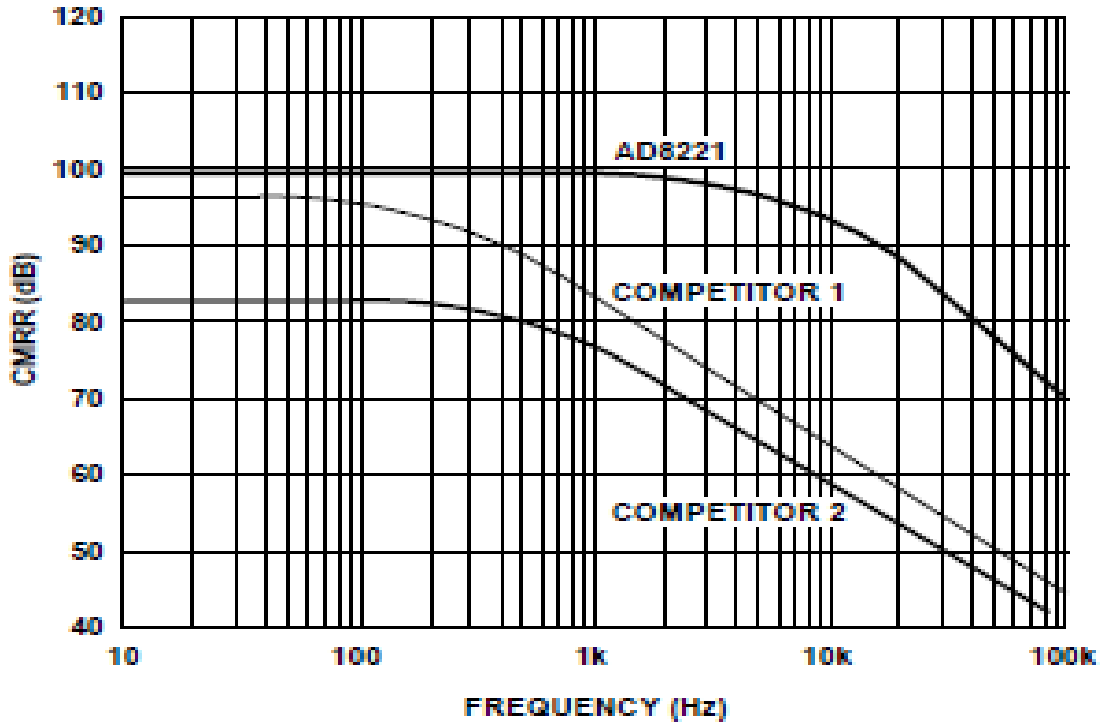

Fig. 9 – CMRR vs frequency at $G = 1$.

3.2.2 Low pass filter:

A low pass filter permits signals with frequencies lower than the roll off frequency to pass through it and constricts the frequency greater than the roll off frequency. The low pass filter is used here to cut out the high frequency artefact signals i.e. electromyographic signals. Here we are going to use LM324 to produce a 2nd order Butterworth low pass filter since it has a sharp cut off and a flat frequency response. Here in this case roll off frequency is 70 Hz.

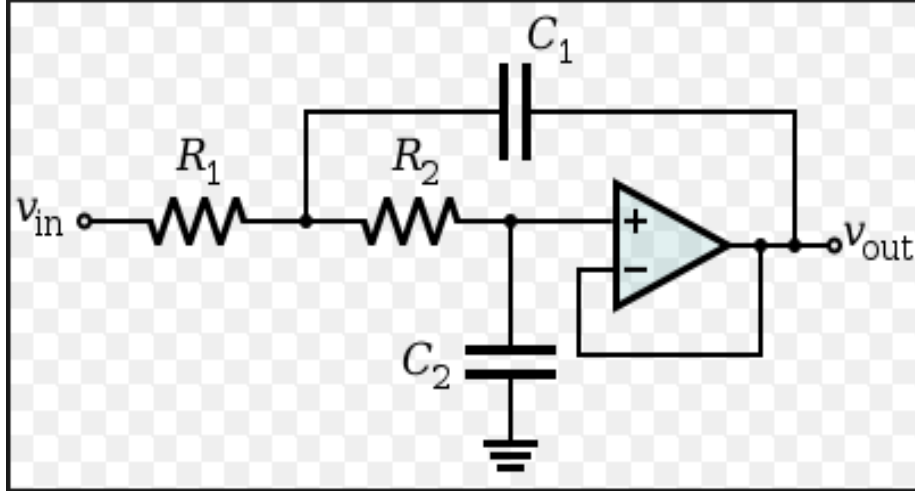

Fig. 10 – Second order low pass filter.

So for the derivation of transfer function of the filter we need to apply KVL and KCL here. Using virtual ground concept $V_{+ve} = V_{-ve} = V_{out}$. Now applying KCL at node 1

$$\frac{V_{in} - V_1}{R_1} = \frac{V_1 - V_{out}}{X_{c1}} + \frac{V_1 - V_{+ve}}{R_2} \quad (1)$$

Now, since $V_{+ve} = V_{-ve} = V_{out}$ we have,

$$\frac{V_{in} - V_1}{R_1} = \frac{V_1 - V_{out}}{X_{c1}} + \frac{V_1 - V_{out}}{R_2} \quad (2)$$

Now applying virtual ground concept and KCL at V_{+ve} we have

$$\frac{V_1 - V_{out}}{R_2} = \frac{V_{out}}{X_{c2}} \quad (3)$$

$$\text{i.e. } V_1 = V_{out} \left(\frac{R_2}{X_{c2}} + 1 \right) \quad (4)$$

Combining equations (2) and (4) we have

$$\frac{V_1 - V_{out} \left(\frac{R_2}{X_{c2}} + 1 \right)}{R_1} = \frac{V_{out} \left(\frac{R_2}{X_{c2}} + 1 \right) - V_{out}}{X_{c1}} + \frac{V_{out} \left(\frac{R_2}{X_{c2}} + 1 \right) - V_{out}}{Z_2} \quad (5)$$

Simplifying equation (4) we get the transfer function as

$$\frac{V_{out}}{V_{in}} = \frac{X_{c1} X_{c2}}{R_1 R_2 + X_{c1} (R_1 + R_2) + X_{c1} X_{c2}} \quad (6)$$

Substituting the values of $X_{c1} = \frac{1}{sC_1}$, $X_{c2} = \frac{1}{sC_2}$ and comparing with the transfer function of second order filter i.e. $\frac{\omega^2}{s^2 + 2\beta s + \beta^2}$ at gain = 1 we get

$$\omega = 2\pi f = \frac{1}{\sqrt{R_1 R_2 C_1 C_2}} \text{ and}$$

$$2\beta = 2\zeta\omega = \omega/Q = \frac{1}{C_1} \left(\frac{R_1 + R_2}{R_1 R_2} \right)$$

$$\text{Therefore } Q = \frac{\omega}{2\beta} = \frac{\sqrt{R_1 R_2 C_1 C_2}}{C_2 (R_1 + R_2)} \text{ where}$$

f = undamped frequency, Q = quality factor, β = attenuation and ζ = damping ratio. Here in our case we have taken $R_1 = R_2$. So putting the values of frequency and resistance we get the values of capacitances i.e. $R_1 = R_2 = 225\text{k}\Omega$, $f = 70\text{Hz}$, $C_1 = 0.02\mu\text{F}$ and $C_2 = 0.01\mu\text{F}$.

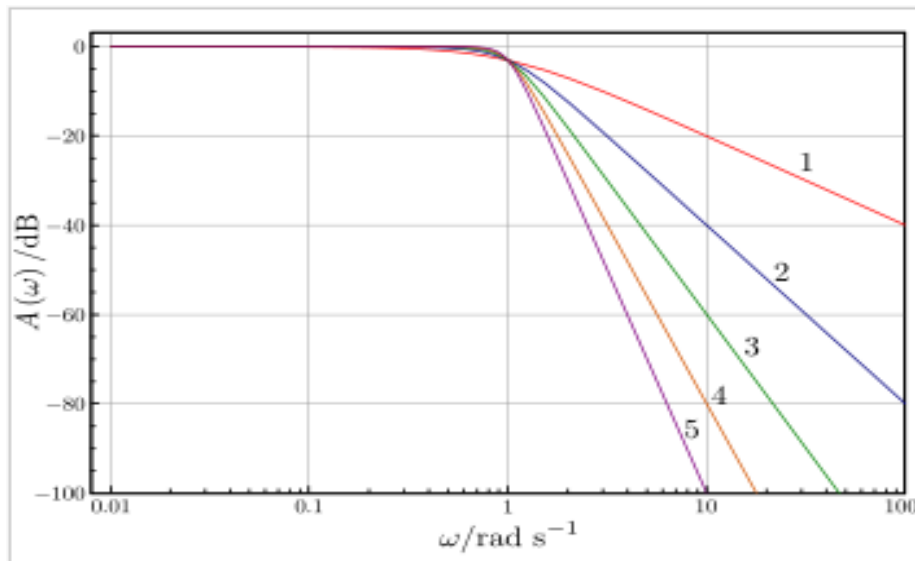

Fig. 11 – Response of low pass butterwoth filter with varying orders.

3.2.3 High Pass filter:

A high pass filter permits signals with frequencies greater than the roll off frequency to pass through it and constricts signals with frequency lower than the roll off. The high pass filter is used here to remove the low frequency artefacts i.e. electro galvanic signals and artefact created by body movement. We are going to continue with the same procedure as in the production of low pass filter. The cut off frequency here is 0.5 Hz. So comparing the derived transfer function with the general transfer function $\frac{S^2}{S^2 + 2\zeta\omega S + \omega^2}$ of second order high pass filter we get $\omega = 2\pi f = \frac{1}{\sqrt{R_1 R_2 C_1 C_2}}$ and

$$2\zeta\omega = \frac{\omega}{Q} = \frac{1}{2\zeta} = Q = \frac{\omega}{2\beta} = \frac{\sqrt{R_1 R_2 C_1 C_2}}{R_1(C_1 + C_2)}$$

$$\text{Therefore } 2\beta = 2\zeta\omega = \frac{\omega}{Q} = \frac{C_1 + C_2}{R_2(C_1 C_2)}$$

Here we are taking $C_1 = C_2$. So after putting the values of capacitances and the desired frequencies we found the values of resistances here:

For $f = 0.5\text{Hz}$ we get $R_1 = 200\text{k}\Omega$, $R_2 = 400\text{k}\Omega$ and $C_1 = C_2 = 1\mu\text{F}$.

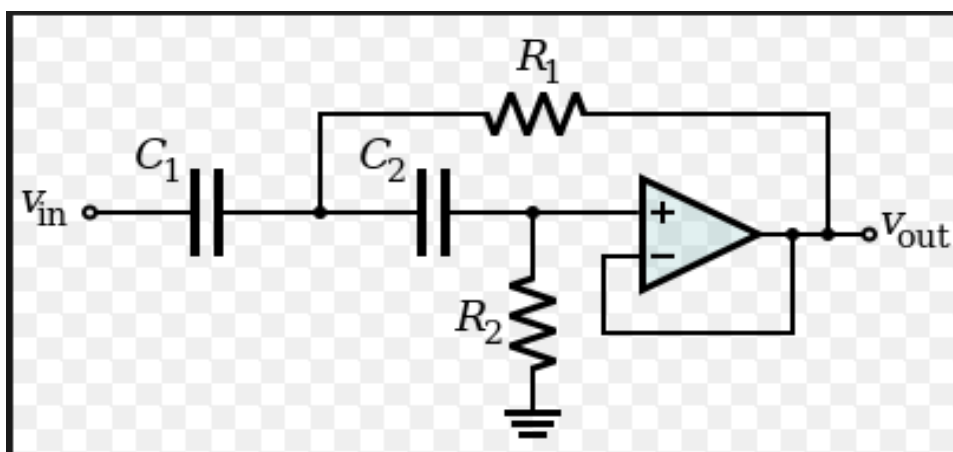

Fig. 12 – second order high pass filter

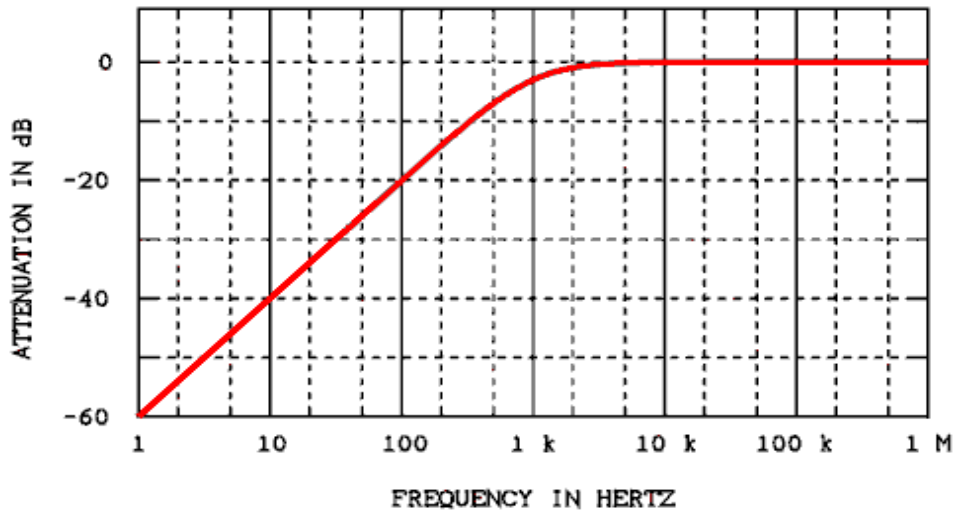

Fig. 13 – high pass filter response

3.2.4 Notch filter:

A filter that passes most of the frequencies unchanged but attenuates a particular band of frequency is known as a band stop filter. A notch filter is a kind of band stop filter that attenuates a narrow band of frequency i.e. has a narrow stop band. Here in our case we are using it to reduce noise of a particular frequency which has encountered into our experiment from outside the acquisition system such as electrical power lines, connectors and mainly from the fluorescent tube present inside the laboratory. As an example, with a wire of length one metre and eight prevailing fluorescent tubes can introduce 100mV noise at 60Hz frequency which we all know is commensurable enough to bury our low level EEG signal.

Prevailing EEG acquisition systems commonly use 24 bit high resolution ADC's (analogue to digital converters) to sample the transmitted EEG signals unswervingly from the wired cables and remove 60Hz noise signals from the recorded EEG signals using digital filter. Nevertheless, an analogue to digital converter with 24 bit resolution will be expensive if we will go on for the best one that will satisfy our requirements such as power communication bandwidth, sampling rate and power. An effortless and elementary way to resolve this noise complication is to build up a 60Hz notch filter (narrow band stop filter) to remove the 60Hz electrical noise before the ADC. Then a 8 bit ADC will be commensurable enough to process the noise free signal.

Passive analogue filters are most commonly used to remove the noise component. Passive filters have the property of forbidding the noise signal from the power lines specifically when dealing with small signals. So for the sake of the formation of a 60Hz notch filter passive components such as resistances, capacitances and inductances are required to lessen the frequency to 60 Hz. As we all know that it is severe to manufacture a filter with large inductance and small resistance value it would be better to deal with only resistors and capacitors which appear to be practical and inexpensive choice.

So a RC coupled band stop filter is designed to solve our purpose which will introduce very low impedance at resonant frequency when the ratio of values of resistors and capacitors will be satisfied in figure 11. Theoretically a large gain to rejection ratio could be obtained since it has a very low impedance at resonant frequency but practically due to some variations between resistance and capacitance values approximately -30dB rejection ratio is calculated for our designed filter.

So in order to remove the noisy component even more a second order narrow band stop filter is required. A second order narrow band stop filter is the series combination of two first order band stop filters. These first order band stop filters have different frequencies 55Hz and 65Hz. From the figure shown below the rejection ratio at 60Hz will attain 50dB. Moreover the -50 dB rejection bandwidth will reach 20Hz. Nevertheless as a settlement the high rejection at 60Hz this second order narrow band stop filter has comparatively high rejection from 10Hz to 30Hz which includes valuable EEG signal. Time domain curve is also introduced in which the green line is input whereas the output is indicated by the blue line. Analysing the time domain curve it could be concluded that the low frequency signals had been debilitated a lot which results in 10 times smaller magnitude of the output signal relative to the input signal. The second order narrow band stop filter is used only in complex electromagnetic surrounding.

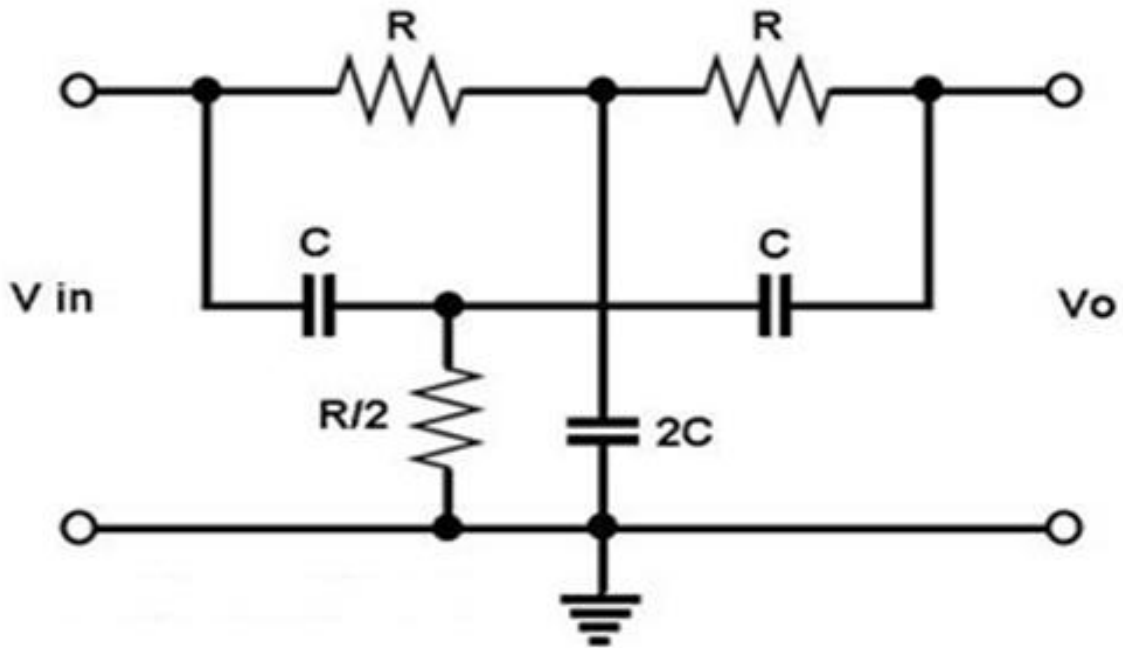

Fig. 14 – Schematic of notch filter

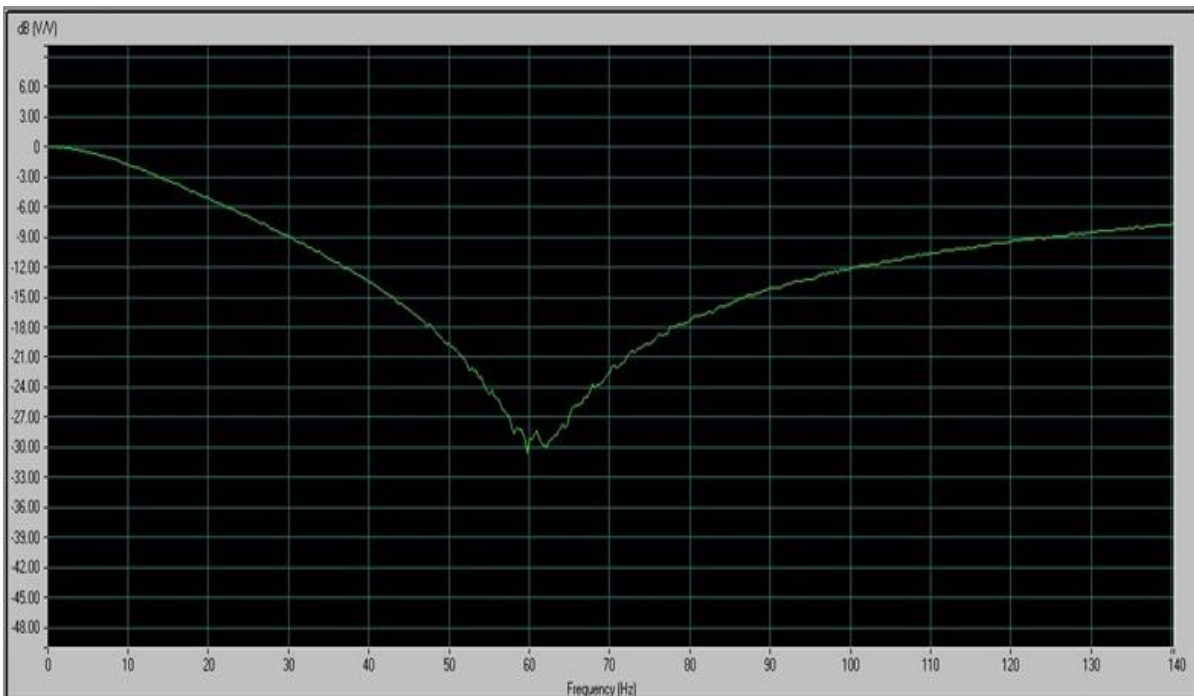

Fig. 15 – Response of first order notch filter.

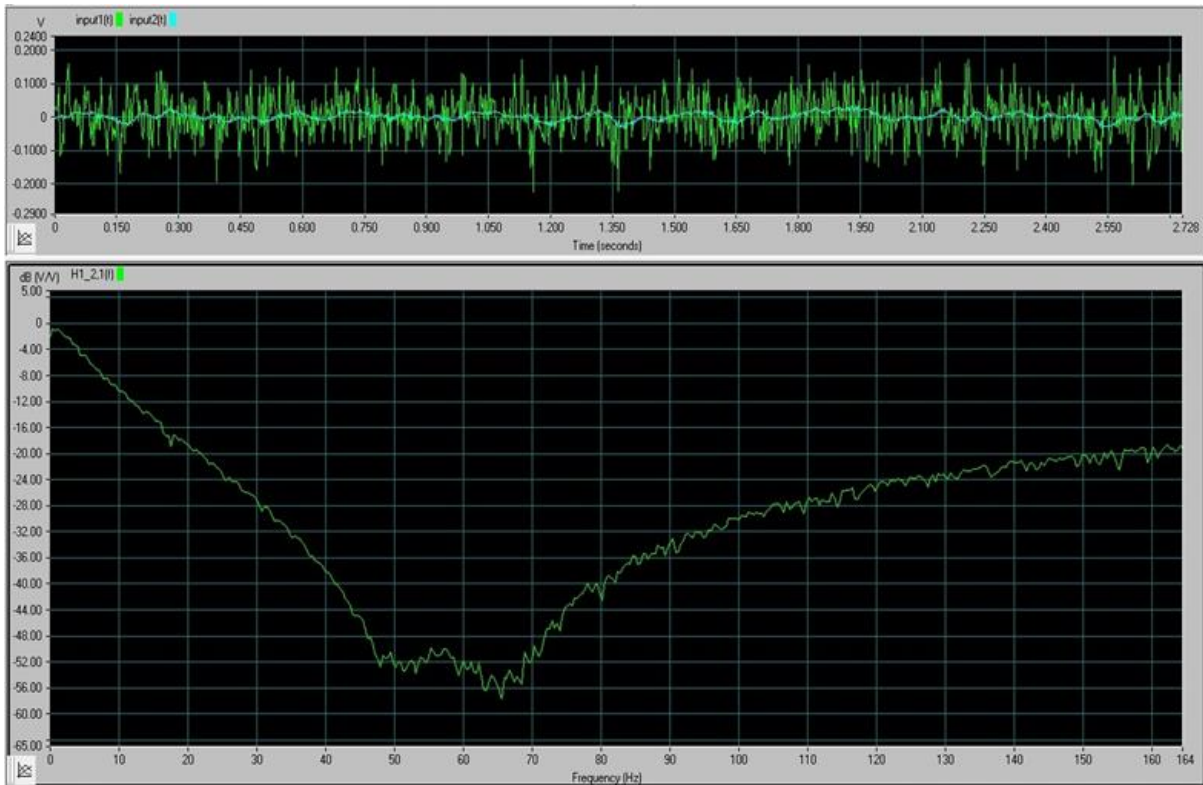

Fig. 16 – Response of second order notch filter.

3.2.5 Analogue to digital converter:

An ADC is an instrument that converts analogue signal (voltage mostly) to digital signal representing its amplitude. The ADC can perform multiple conversions which results in digital signal with discrete time and amplitude from continuous time and amplitude signal. The ADC is described by its bandwidth and SNR. The actual bandwidth is typified by its sampling rate and its error handling capability.

24 bit is the maximal ADC resolution available in market recently. The raw data sampling is done by the amplifier and filter layer after which the sampled signal is enforced to the digital filter to cut out the 60Hz noisy components accurately. 60Hz noise is the basic component of raw signal in which the SNR (signal to noise ratio) is approx 0.03.

The above designed notch filter has -50dB rejection at 60Hz frequency which means that our 60Hz noisy component problem will be solved by this filter and the SNR can achieve a

different value i.e. $1/0.3$ after the notch filter. In other words we can say that 24 bit ADC will have the same resolution as the 16bit ADC when 60Hz notch filter is placed before it.

Since the noisy signal is removed, an ADC with 8 bit resolution is placed after the notch filter which is sufficient enough to sample the EEG signal. In our project 8 bit ADC is used for demonstration. This 8 bit resolution could be varied from 8 to 12 to 14 or other resolutions by changing the parameters in coding.

It is appealing to note that there is a settlement betwixt resolution and sampling frequency of the ADC. That's why it takes extra time to complete a sample for ADC's with higher resolution.

Conversion time of ADC = clock period * resolution bits getting converted.

For single channel applications an ANALOG DEVICES product ADC0804 is preferred for realization of our system. For 16 channel applications ATMEGA introduced microcontroller board with inbuilt ADC is preferred. Both of these ADC's could achieve a sampling frequency of 400Hz with 12 bit resolution which is satisfactory to sample EEG signal.

There are some key features of ADC0804:

- (a) On chip clock
- (b) Adaptable to 8080 microprocessor derivatives, no interfacing required
- (c) 0 – 5V range with 5V power supply
- (d) 8 bits resolution
- (e) 100 micro second conversion time
- (f) Available in 20 pin DIP and SOIC packages.

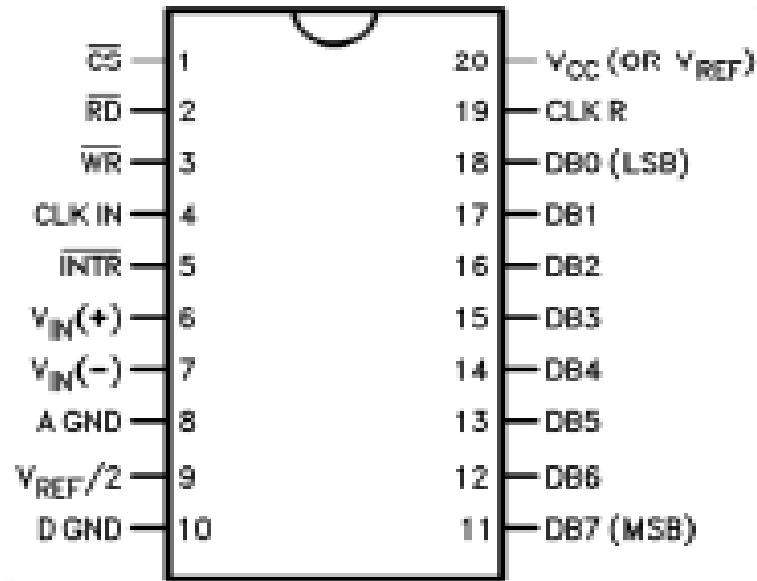

Fig. 17 – ADC0804 pin diagram

3.2.6 8051 Microcontroller Board:

Since we are using ADC for the conversion of signals from analogue to digital we need a device to display the digitized signals on to the LCD to ensure that our circuit is working properly as well as to send it to the wireless module so that it could be transmitted to the receiver end. For this subsequent process we need a multipurpose device which can satisfy our requirement. In our case we have used a 40 pin 8051 microcontroller with 4 ports with 8 pins each, and has its internal clock frequency generated by crystal oscillator.

The 8051 is the most common microcontroller in use currently. These microcontrollers are referred as MCS51 family of microcontrollers produced by ATMEL, TEXAS INSTRUMENTS etc. These are available in DIP, PQFP/TQFP and PLCC packages.

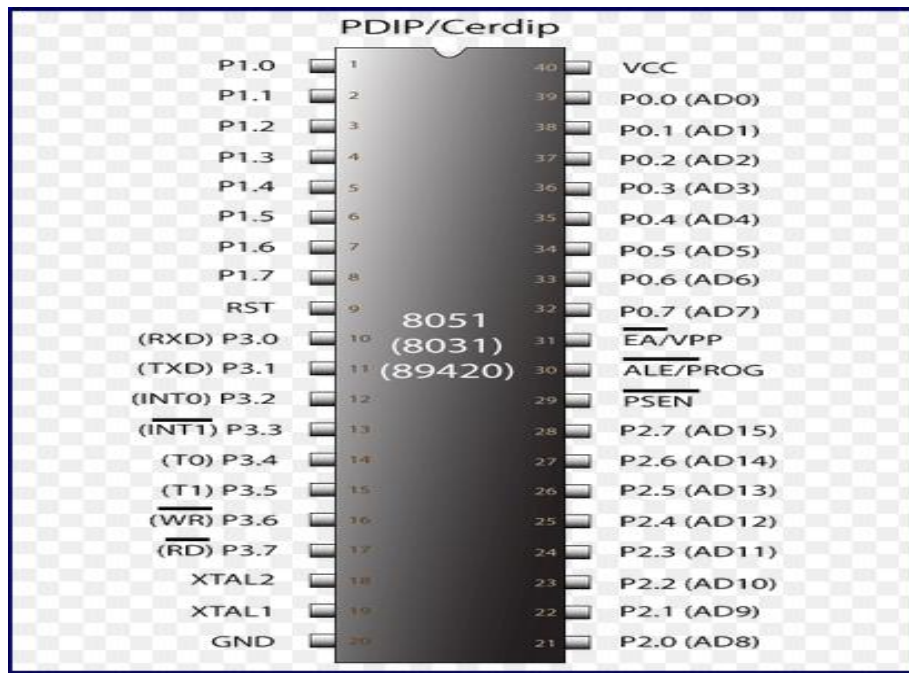

Fig.18 - 8051 pin diagram.

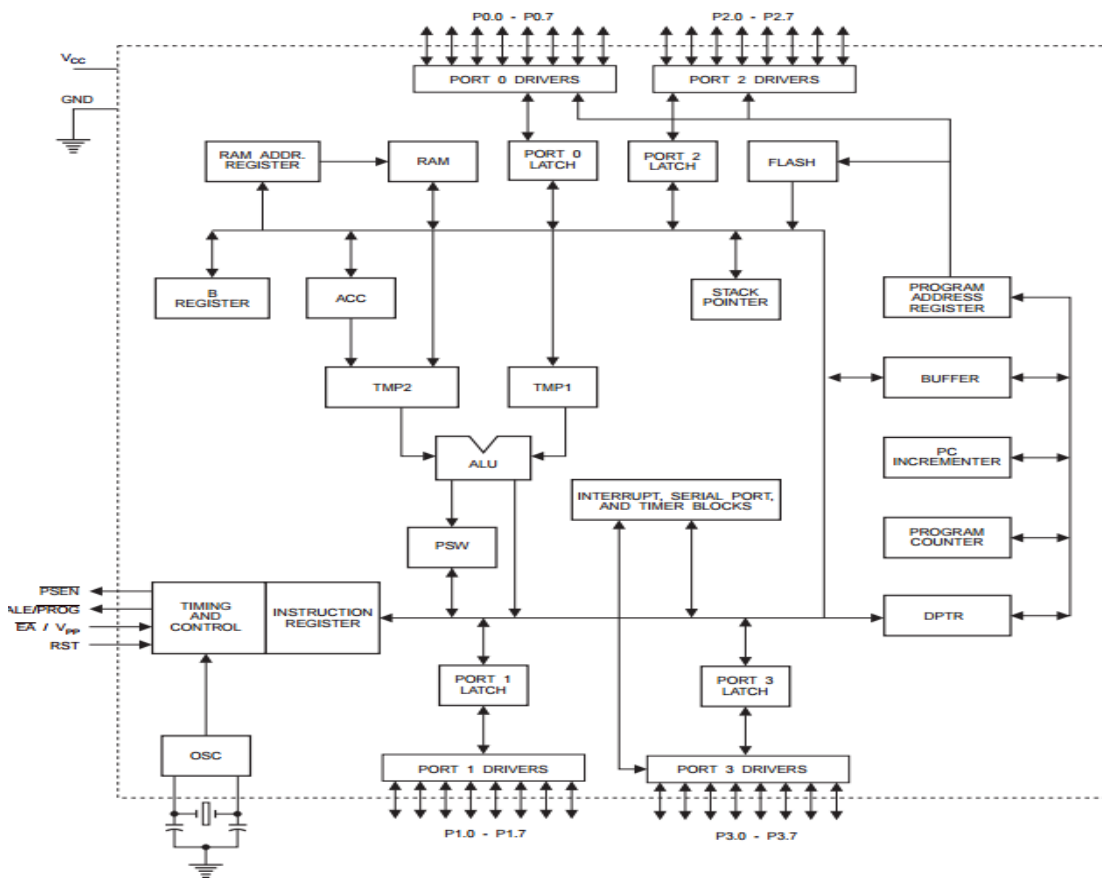

Fig. 19 – 8051 internal schematics.

A 40 pin 8051 microcontroller board consists of onboard 16X2 LCD, 4 LED's (light emitting diode), 4 switches, power supply circuit, reset switch, status LED, RS232 serial standard port for interfacing with other devices. This board supplies enlargement for all ports and hole for each I/O pin which can be used for further expansion. These boards are excellent for learning, experimenting and development. The board provides support for LCD's contrast control and number of general purpose LED's and switches. These LED's and switches are linked with the microcontroller to its I/O pins through jumpers. Some features of this board are:

- (a) Provides easy communication.
- (b) Accepts both DC and AC inputs due to the presence of bridge rectifier.
- (c) Provides LM7805 regulator for heat sinking.
- (d) Onboard crystal oscillator.

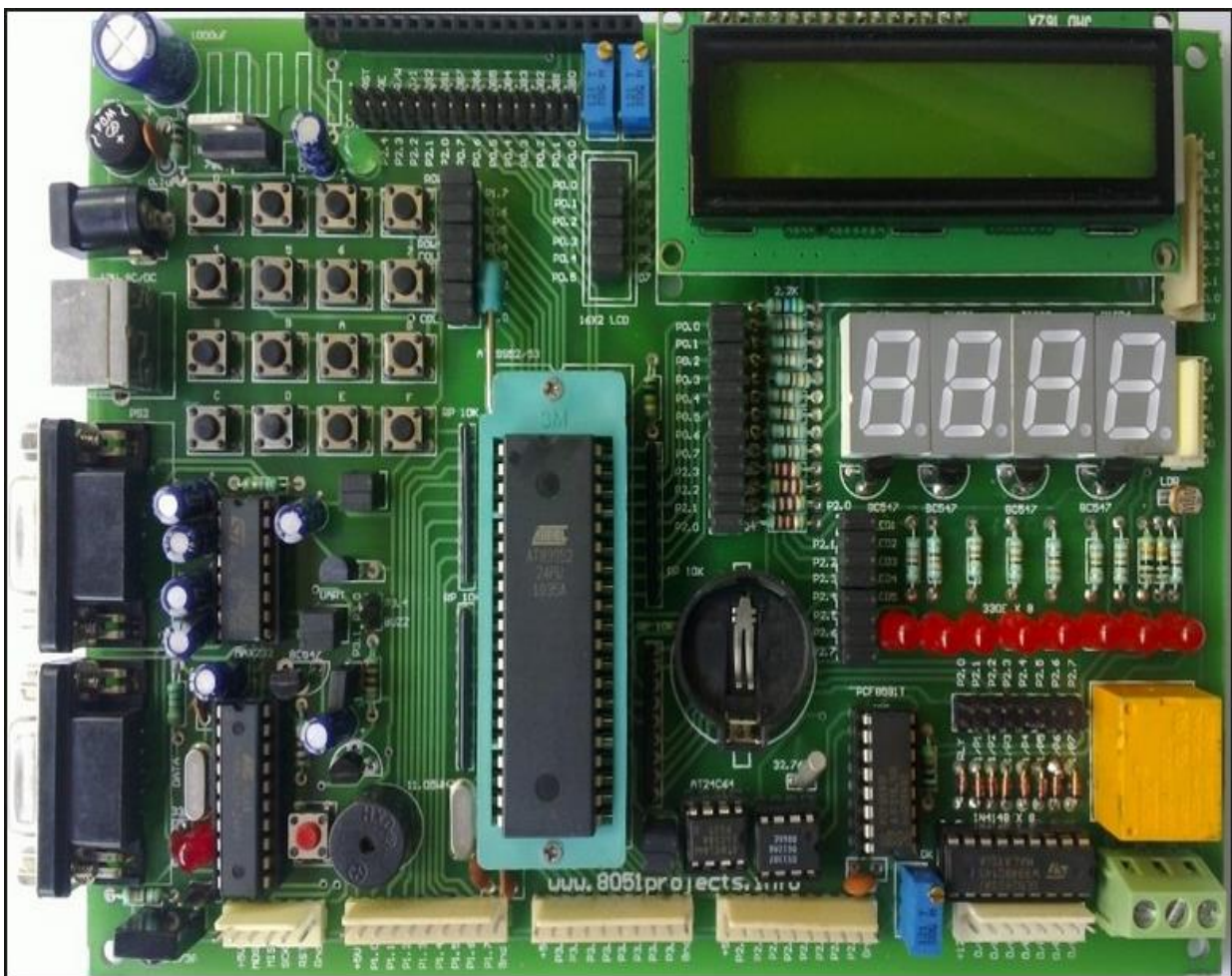

Fig. 20 – 8051 microcontroller board.

Components connection with microcontroller:

- (a) **Switches** – There are four switches in the microcontroller board. SW1, SW2, SW3, are linked to port 3 of at 1st, 2nd and 3rd bit positions respectively. SW1 and SW2 are interrupt switches. The fourth switch is used to reset the microcontroller.
- (b) **Sensors** – Four sensors are connected to address data pins of port 2 i.e. sensors 1, 2, 3, 4 is connected to 7, 6, 5, 4 pins of port 2. This port could be used to interface ADC input with 8/16 bits resolution. +ve and –ve supplies are connected to Vcc and GND.
- (c) **LCD** – LCD have three control pins and data pins. Among the three control pins RW is connected to ground whereas RS and EN are connected to port 1 at bits 4 and 5 respectively. All the three data pins are connected to port 0 at bits 0 – 3.
- (d) **LED** – Five LED's are fixed in this board one of which is the status LED used for power supply indication. LED's 2 and 3 are connected to port 3 at bit positions 0 and 1 respectively. LED 1 is connected to port 1 at bit 6. The fourth one is the coding LED.
- (e) **Motor driver IC** – There are two motor drivers connected to port 2 among which first one is connected to bit positions 0 – 3 while the second one to bit positions 4 -7 respectively.

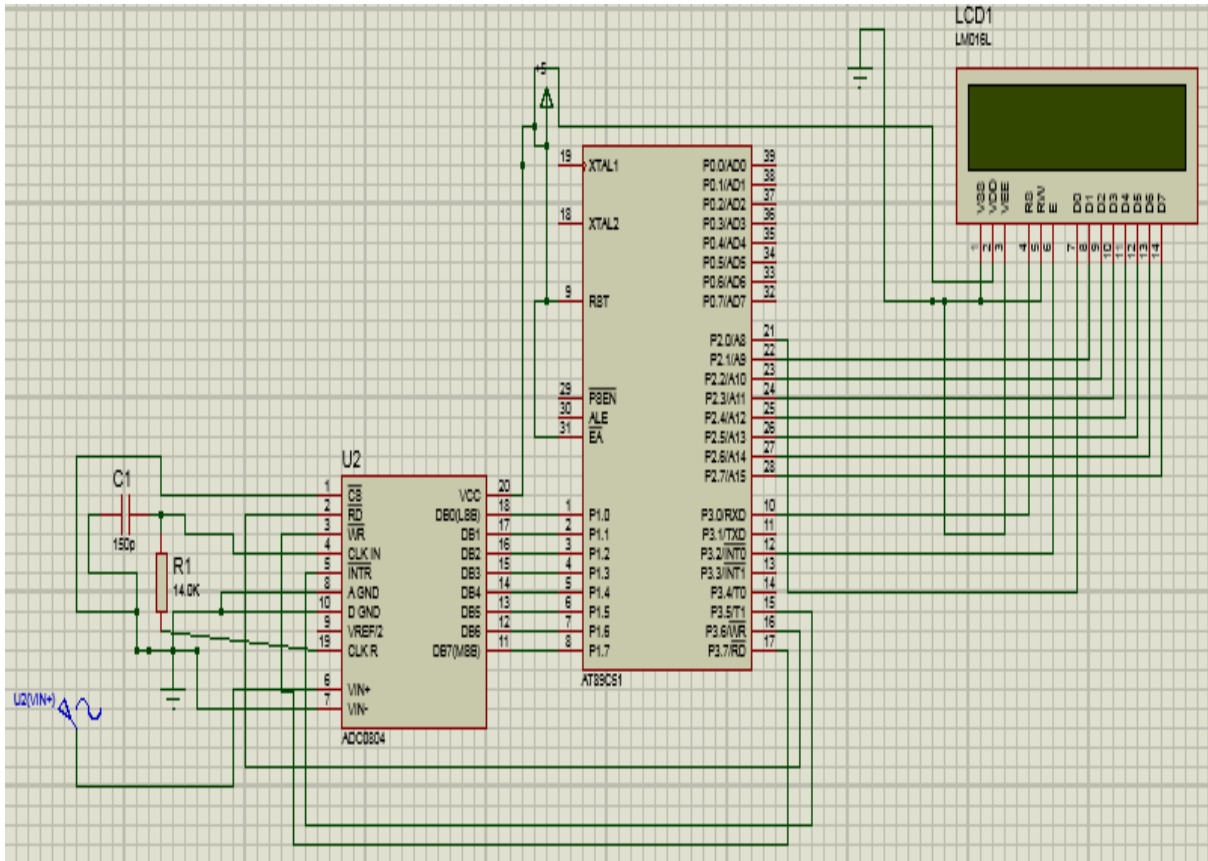

Fig. 21 – ADC and LCD interfacing with microcontroller

3.2.8 Wireless communication module:

The experiment requires low power utilization, relatively higher performance, lower price and compact sized hardware. Considering all these facts Bluetooth communication module is the best choice for the realization of our EEG recording system.

Bluetooth module aims at low power, inexpensive (around Rs. 500) and long communication range (50m) wireless module. These advantages provide widespread application of Bluetooth module in near future.

A straightforward easy approach for wireless communication realization is the ZL70102 (ZL - Zaralink) and ZL70321 (latest version of ZL70102) which is the integrated solution in MICS (multiple implant communication service) band of 402 – 405MHz with 800Kbps data transfer rate and a little current consumption of about 5mA. The ZL70102 chip's custom

design allows patient's data to be transmitted quickly with a little use of battery. The ZL70102 can be installed both in medical equipment's and base stations.

The ZL70102 chip is very adaptable and supports many low power wake up operations from base station. Low power action is accomplished using the 2.45GHz band wake up option at receiver. A hovering level of integration involves a MAC (media access control) responsible for coding and decoding of messages, CRC check (cyclic redundancy check), error detection and correction to accomplish a safe and stable communication link with BER (bit error rate) less than 10^{-10} . The ZL70102 is controlled digitally by the microcontroller through RS232 interface and allows integration with analogue circuit. According to our preferences in data transmission we have various battery options i.e. for limited transmission we go with 1200mAh lithium ion battery and for maximum transmission we need 2800mAh lithium ion battery. The ZL70102 is available in 43 pad LGA packages. Its key features include:

- (a) Operates in 433 – 434MHz frequency range for two ISM channels and 402 – 405 MHz for 10 MICS channels.
- (b) Higher data rates, bidirectional and efficient data transmission.
- (c) Low power consumptions extend battery life.
- (d) Better error detection and correction capacity.

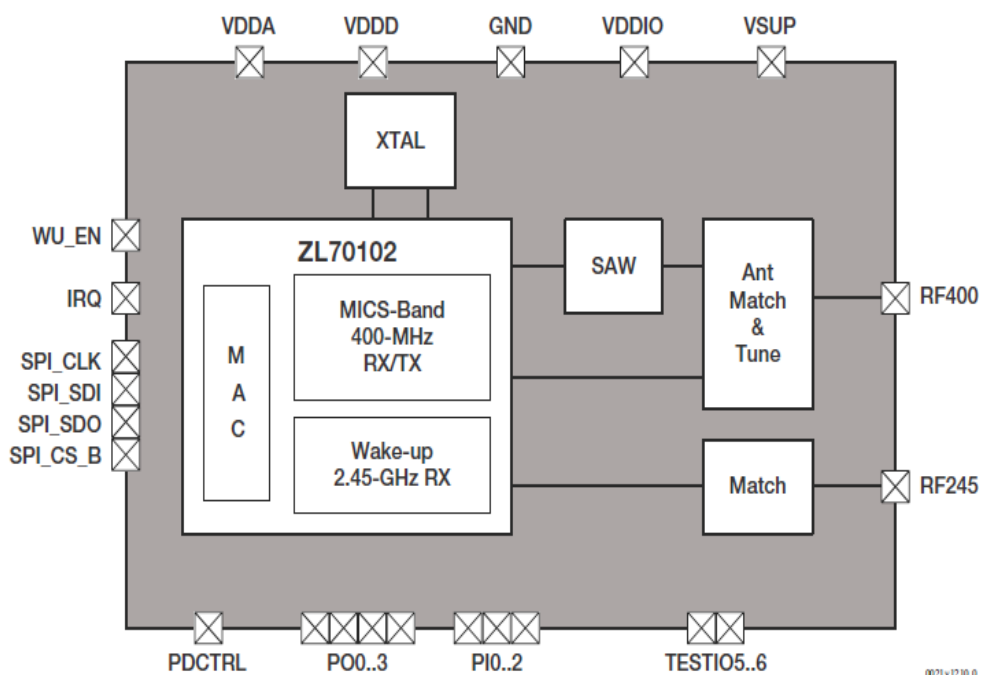

Fig. 22 – simplified block diagram of ZL70321.

CHAPTER 4

DEVELOPING GRAPHICAL USER INTERFACE

Lab VIEW stands for laboratory virtual instrumentation workbench. It was evolved by National Instruments. It provides system designing platform in a visually programmed language. Lab VIEW has evolved as a most common programming language for data acquisition and recording recently. National Instruments had given 14 new Lab VIEW versions in last 24 years for it to be easily accessible and user friendly to develop any kind of instrumentation hardware. Moreover, based on visual programming it has dominance in handling real world signals. It is flexible enough in connections with various ports and hardware as well as has user friendly GUI. Considering the above Lab VIEW has been chosen for the development of our EEG recording system.

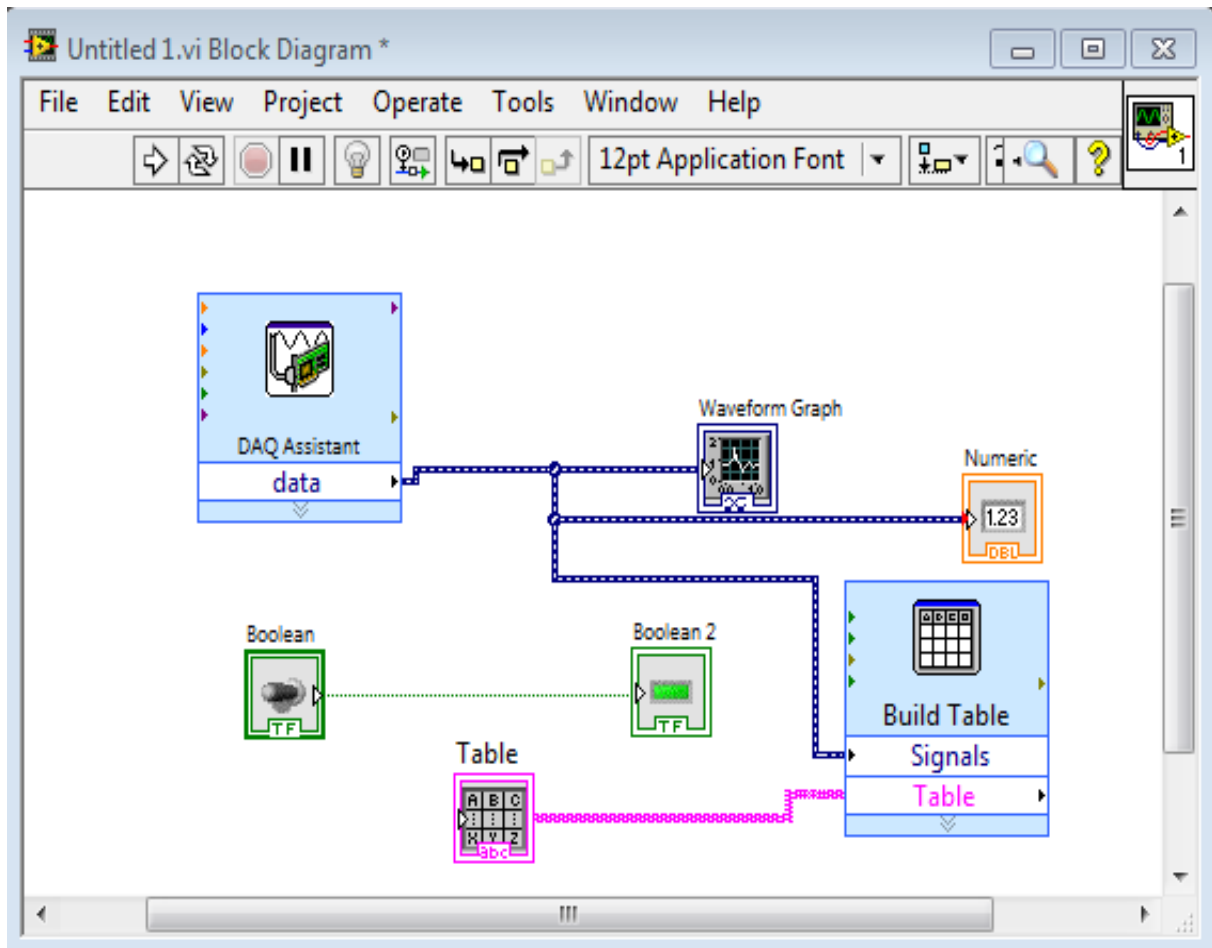

Fig. 23 – Block diagram for signal acquisition

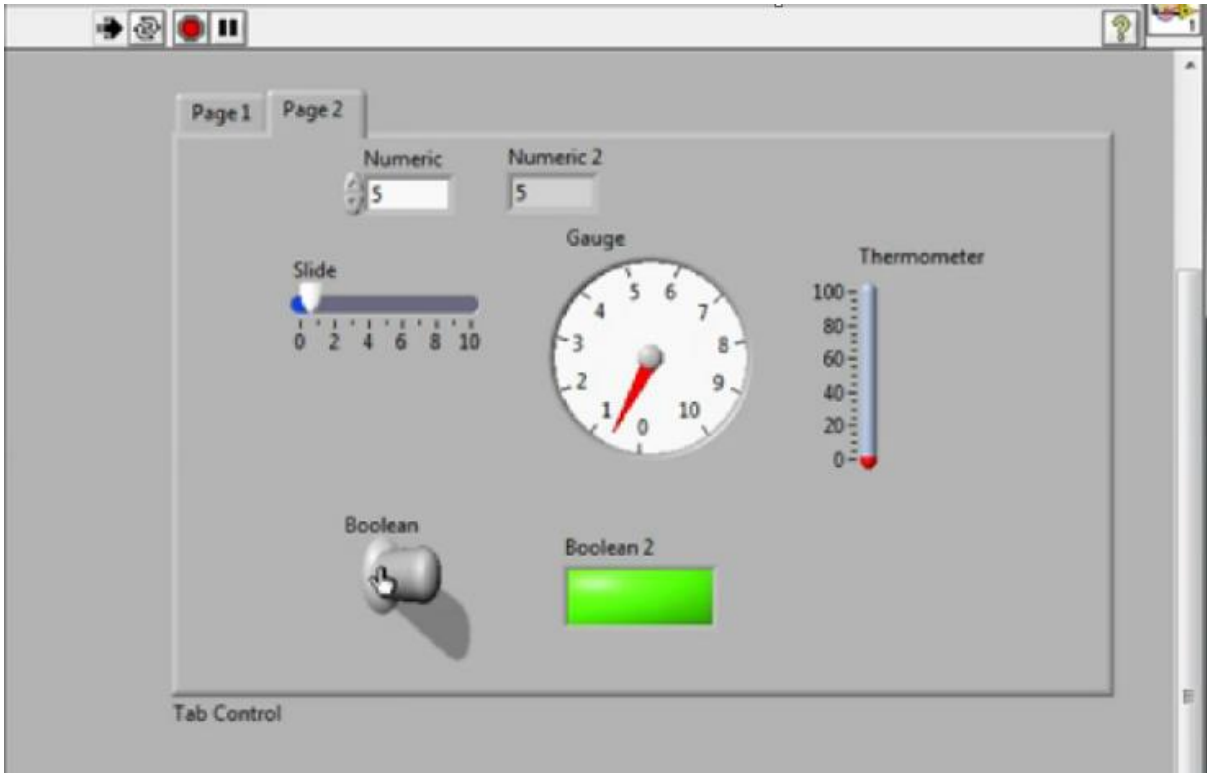

Fig. 24 – Front panel numeric indicators

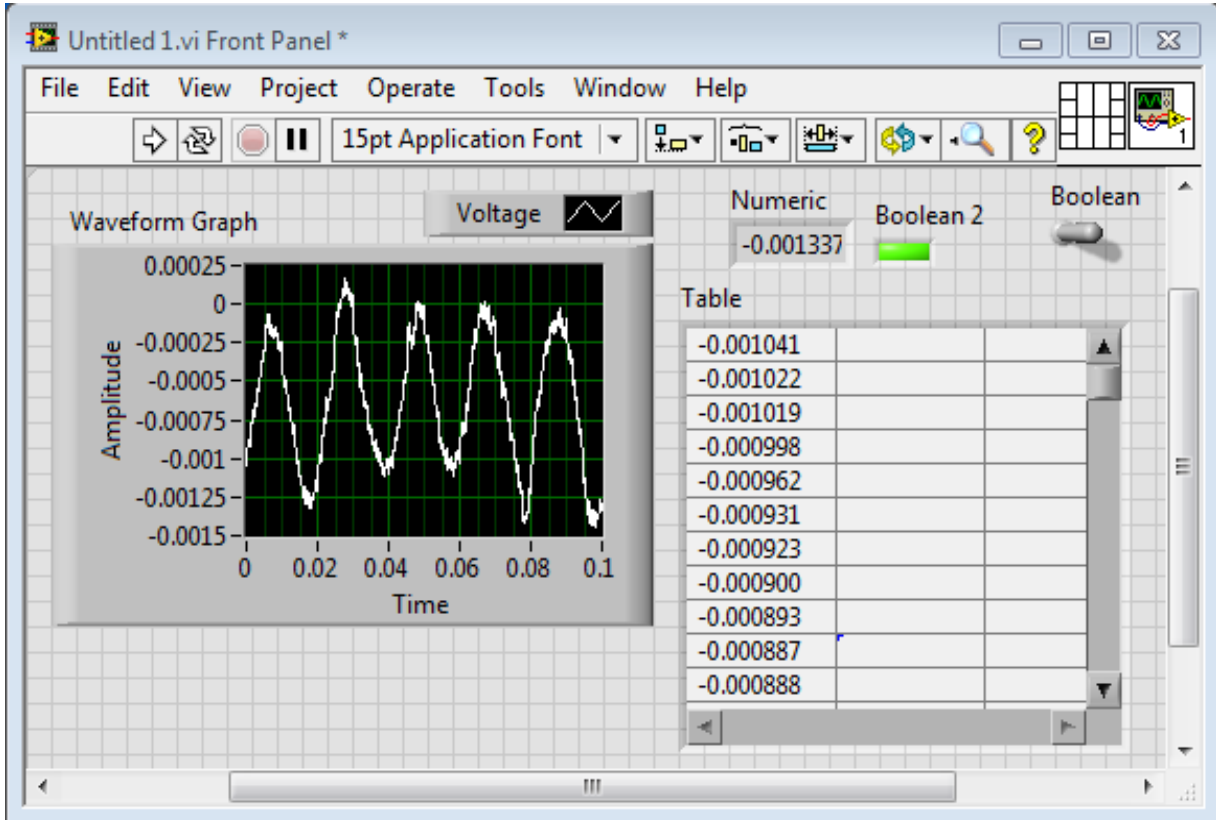

Fig. 25 – Front panel waveform graph

CHAPTER 5

RESULT AND CONCLUSION

5.1 RESULT:

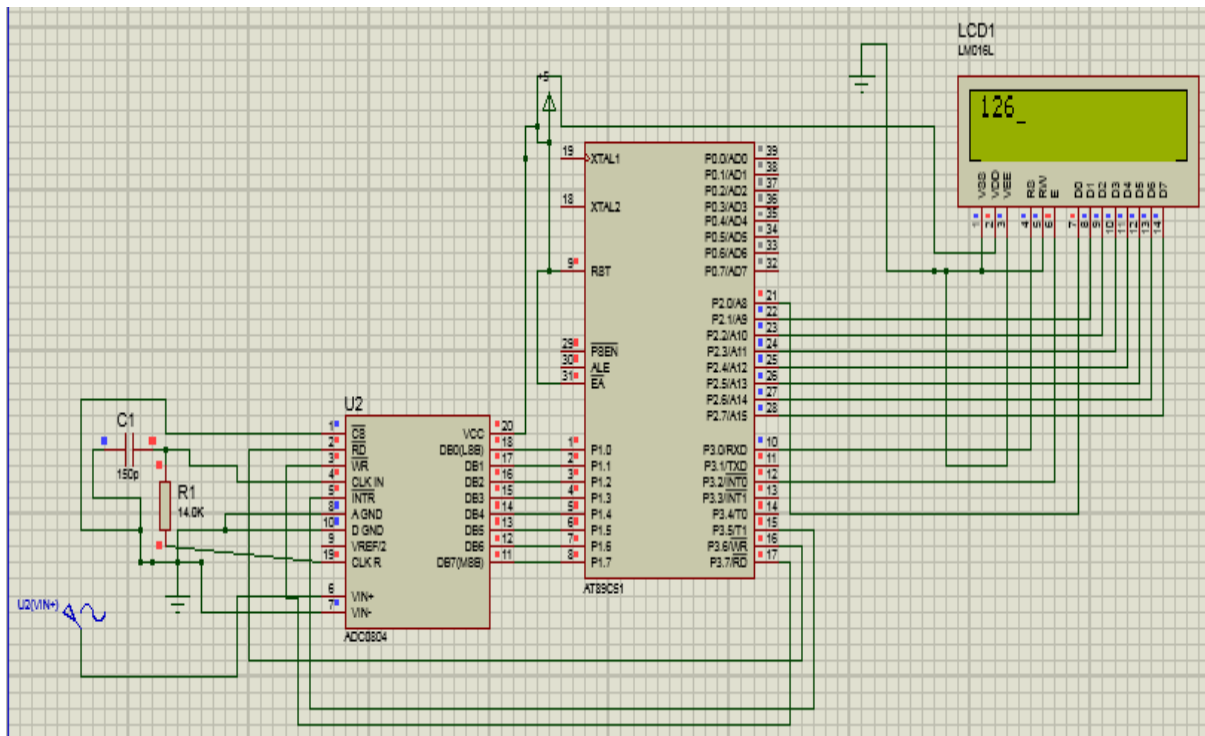

Fig. 26 – Digital circuit output.

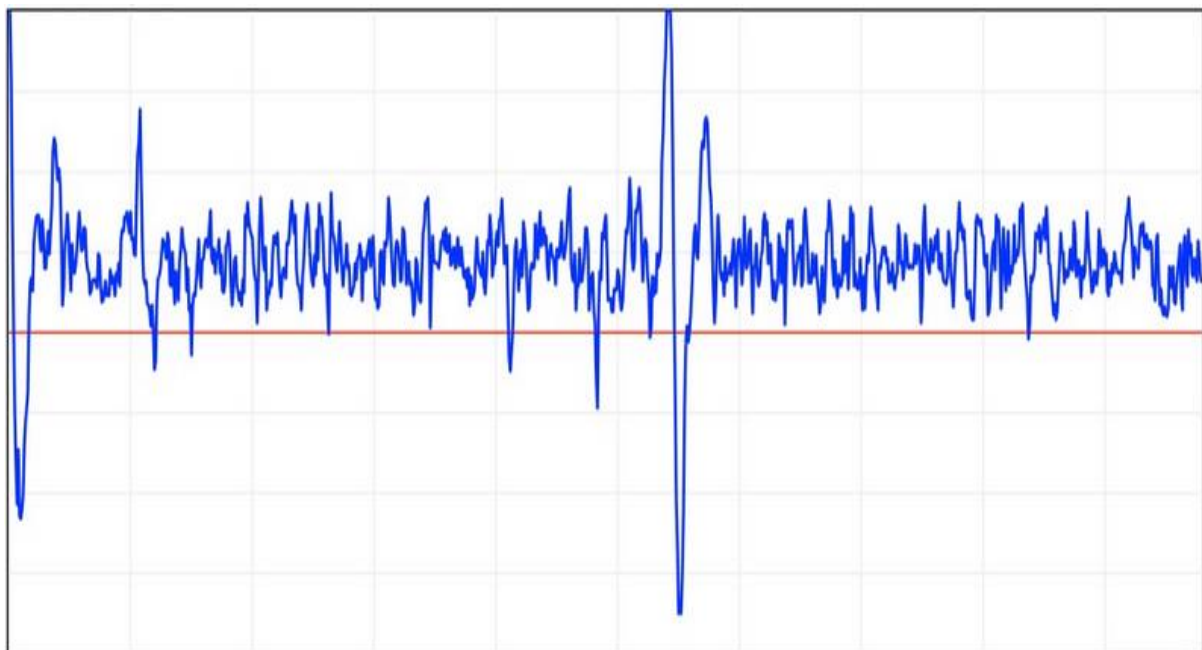

Fig. 27 – EEG waveform.

The Non invasive single channel wireless EEG device is developed above. It is light in weight and can be fixed to human body to reduce inconvenience and discomfort. Based on the 10 – 20 system a cap made up of neoprene material is used for localisation of electrodes. Some features of the purposed EEG recording system over the existing conventional system is:

- (a) Power consumption reduction up to 2.2 Watt.
- (b) Wireless module includes Bluetooth technology with 84Kbps successful data transfer rate.
- (c) Sampling frequency is 400Hz with 8 bit resolution.

5.2 CONCLUSION:

A wireless non invasive EEG acquisition and recording system for observing single channel EEG signals is purposed in this thesis. This system is convenient and comfortable to the patient allowing him to perform his daily life tasks without any bulky wired environment. This system has a wireless connection between acquisition and recording circuit which makes it more preferable than the existing system. The future works will be aiming towards reduction in size, noise introduced to the system and power consumption and increase in number of channels.

REFERENCES

- [1] L. F. Haas, “Hans Berger (1873-1941), Richard Caton (1842-1926), and electroencephalography,” *Journal of Neurology, Neurosurgery and Psychiatry*, vol. 74, p. 9, 2003.
- [2] J. J. Carr and J. M. Brown, *Introduction to Biomedical Equipment Technology*, 4th edition, New Jersey, USA: Prentice Hall, 2001.
- [3] Webster JG, *Medical Instrumentation: Application and Design*, 3rd edition, John Wiley and Sons Inc, New York, 1998.
- [4] M.J. Burke and D.T. Gleeson, A micro power dry-electrode ECG preamplifier, *IEEE Trans. Biomed. Eng.* Vol. 47, pp. 155–162, 2000.
- [5] M. Fifer, S. Acharya, H. Benz, M. Mollazadeh, N. Crone, and N. Thakor, “Toward electrocorticographic control of a dexterous upper limb prosthesis: Building brain-machine interfaces,” *IEEE Pulse*, vol. 3, no. 1, pp. 38–42, Jan. 2012.
- [6] I. H. Stevenson and K. P. Kording, “How advances in neural recording affect data analysis,” *Nature Neurosci.*, vol. 14, pp. 139–142, 2011.
- [7] R. F. Yazicioglu, T. Torfs, P. Merken, J. Penders, V. Leonov, R. Puers, B. Gyselinckx, and C. VanHoof, “Ultra-low-power biopotential interfaces and their applications in wearable and implantable systems,” *Microelectron.J.*, vol. 140, pp. 1313–1321, 2009.
- [8] S. S. Spencer, D. K. Nguyen, and R. B. Duckrow, “Invasive EEG in presurgical evaluation of epilepsy,” in *The Treatment of Epilepsy*, S. Shorvon, E. Perucca, and J. Engel, Eds., 3rd ed. Hoboken, NJ, USA: Wiley–Blackwell, 2009, pp. 767–798
- [9] Nicolelis, MA. Brain-machine interfaces to restore motor function and probe neural circuits. *Nat. Rev. Neurosci.* 4(5), 417-422, (2003).
- [10] Wolpaw, JR., McFarland, DJ., Neat, GW., Forneris, CA. An EEGbased brain-computer interface for cursor control. *Electroencephalogr.Clin.Neurophysiol.*78, 252-259 (1991).
- [11] Leuthardt, EC., Miller, KJ.,Schalk, G., Rao, RP., Ojemann, JG. ECoG-based brain computer interface--the Seattle experience. *IEEETrans. Neural Syst. Rehabil.Eng.* 14, 194-198, (2006).
- [12] Brown, L.; van de Molengraft, J.; Yazicioglu, R.F.; Torfs, T.; Penders, J.; Van Hoof, C.; A low-power, wireless, 8-channel EEG monitoring headset, *Engineering in Medicine and Biology Society (EMBC), 2010 Annual International Conference of the IEEE* , vol., no., pp.4197-4200, Aug. 31 2010-Sept. 4 2010
- [13] J. Connor, R. Norton, S. Ameratunga, E. Robinson, I. Civil, R. Dunn, J. Bailey, and R. Jackson, “Driver sleepiness and risk of serious injury to car occupants: Population based case control study,” *Brit. Med. J.*, vol. 324, pp. 1125–1128, 2002.

- [14] A. Eskandarian and A. Mortazavi, "Evaluation of a smart algorithm for commercial vehicle driver drowsiness detection," in Proc. IEEE Intelligent Vehicles Symp., 2007, pp. 553–559.
- [15] S. Roberts, I. Rezek, R. Everson, H. Stone, S. Wilson, and C. Alford, "Automated assessment of vigilance using committees of radial basis function analysers," Proc. Inst. Elect. Eng., Sci., Meas. Technol., vol. 147, no. 6, pp. 333–338, 2000.
- [16] S. Makeig and M. Inlow, "Lapses in alertness: Coherence of fluctuations in performance and EEG spectrum," *Electroencephalography Clinical Neurophysiol.*, vol. 86, no. 1, pp. 23–35, 1993.
- [17] J. M. Carmena, M. A. Lebedev, R. E. Crist, J. E. O'Doherty, D. M. Santucci, D. F. Dimitrov, P. G. Patil, C. S. Henriquez, and M. A. L. Nicolelis, "Learning to control a brain-machine interface for reaching and grasping by primates," *PLoS Biol.*, vol. 1, p. e42, 10 2003.
- [18] J. P. Donoghue, A. Nurmikko, M. Black, and L. R. Hochberg, "Assistive technology and robotic control using motor cortex ensemble-based neural interface systems in humans with tetraplegia," *The Journal of Physiology*, pp. 603–611, March 2007.
- [19] J. R. Wolpaw and D. J. McFarland, "Control of a two-dimensional movement signal by a non-invasive brain-computer interface in humans," *Proceedings of the National Academy of Sciences of the United States of America*, vol. 101, pp. 17849–17854, December 2004.
- [20] F. Sharbrough, C. Chatrian, R. Lesser, H. Luders, M. Nuwer, and T. Picton, "American Electroencephalographic Society guidelines for standard electrode position nomenclature," *J. Clin. Neurophysiology*, vol. 8, pp. 200–202, 1991.
- [21] K. Stamps and Y. Hamam, "Towards inexpensive BCI control for wheel chair navigation in the enabled environment—A hardware survey," in Proc. 2010 Int. Conf. Brain Informat., Toronto, ON, Canada, 2010, pp. 336–345.
- [22] T. M. Sokhadzeet al., "EEG biofeedback as a treatment for substance use disorders: Review, rating of efficacy, and recommendations for further research," *Appl. Psychophysiol. Biofeedback*, vol. 33, pp. 1–28, 2008.
- [23] J. F. Lubaret al., "Evaluation of the effectiveness of EEG neuro feedback training for ADHD in a clinical setting as measured by changes in T.O.V.A. scores, behavioral ratings, and WISC-R performance," *Biofeedback Self-Regulation*, vol. 20, pp. 83–99, 1995.
- [24] P. Abry and F. Sellan, "The wavelet-based synthesis for fractional Brownian motion proposed by F. Sellan and Y. Meyer: Remarks and fast implementation," *Appl. Comput. Harmonic Anal.*, vol. 3, pp. 377–383, 1996.
- [25] M. Mollazadeh, K. Murari, G. Cauwenberghs, and N. V. Thakor, "Wireless micropower instrumentation for multimodal acquisition of electrical and chemical neural activity," *IEEE Trans. Biomed. Circuits Syst.*, vol. 3, no. 6, pp. 388–397, Dec. 2009.