

# Development of Application Specific Clustering Protocols for Wireless Sensor Networks

Ph. D. Thesis

*by*

Asis Kumar Tripathy



Department of Computer Science and Engineering

National Institute of Technology Rourkela

Rourkela - 769008, India

April 2016

# Development of Application Specific Clustering Protocols for Wireless Sensor Networks

*A dissertation submitted to the department of*

*Computer Science and Engineering*

*of*

*National Institute of Technology Rourkela*

*in partial fulfilment of the requirements*

*for the degree of*

*Doctor of Philosophy*

*by*

*Asis Kumar Tripathy*

*(Roll No- 511CS105)*

*under the supervision of*

*Prof. Suchismita Chinara*



Department of Computer Science and Engineering

National Institute of Technology Rourkela

Rourkela - 769008, India

April 2016



Department of Computer Science and Engineering  
**National Institute of Technology Rourkela**

Rourkela - 769 008, India. [www.nitrkl.ac.in](http://www.nitrkl.ac.in)

April 04, 2016

## Certificate of Approval

Certified that the thesis entitled “*Development of Application Specific Clustering Protocols for Wireless Sensor Networks*” submitted by *Asis Kumar Tripathy*, bearing **Roll No: 511CS105** to National Institute of Technology, Rourkela, for award of the degree of Doctor of Philosophy has been accepted by the external examiners and that the student has successfully defended the thesis in the viva-voce examination held today.

Prof. S K Jena  
Member DSC

Prof. D P Mohapatra  
Member DSC

Prof. S. Maity  
Member DSC

Prof. S Chinara  
Supervisor

Prof. N C Shivaprakash  
External Examiner

Prof. S K Rath  
Chairman DSC



Department of Computer Science and Engineering  
**National Institute of Technology Rourkela**

Rourkela - 769 008, India. [www.nitrkl.ac.in](http://www.nitrkl.ac.in)

**Dr. Suchismita Chinara**

Assistant Professor

April 04, 2016

## Certificate

This is to certify that the work in the thesis entitled “*Development of Application Specific Clustering Protocols for Wireless Sensor Networks*” by *Asis Kumar Tripathy*, bearing Roll No: 511CS105, is a record of an original research work carried out by him under my supervision and guidance in partial fulfillment of the requirements for the award of the degree of *Doctor of Philosophy in Computer Science and Engineering*. Neither this thesis nor any part of it has been submitted for any degree or academic award elsewhere.

*(Suchismita Chinara)*

# Declaration

I certify that,

- a) The work contained in the thesis is original and has been done by myself under the general supervision of my supervisor.
- b) The work has not been submitted to any other Institute for any degree or diploma.
- c) I have followed the guidelines provided by the Institute in writing the thesis.
- d) I have conformed to the norms and guidelines given in the Ethical Code of Conduct of the Institute.
- e) Whenever I have used materials (data, theoretical analysis, and text) from other sources, I have given due credit to them by citing them in the text of the thesis and giving their details in the references.
- f) Whenever I have quoted written materials from other sources, I have put them under quotation marks and given due credit to the sources by citing them and giving required details in the references

*Signature of the student*

*To my loving parents..*

Who always instilled in me the importance of education, and never stopped dreaming about my success, and whose selfless love, devotion, and guidance kept me going.

*We do not remember days, we remember moments.*

Cesare Pavese

## Acknowledgment

Foremost, I would like to express my sincere gratitude to my supervisor Prof. Suchismita Chinara for the continuous support of my Ph.D study and research, for her patience, motivation, enthusiasm, and immense knowledge. Her guidance helped me in all the time of research and writing of this thesis. I could not have imagined having a better advisor and mentor for my Ph.D study.

Besides my supervisor, I would like to thank the rest of my thesis committee: Prof. S. K. Rath, Chairman , Prof. S. K. Jena, Prof. D. P. Mohapatra and Prof. S. Maity, for their encouragement, insightful comments, and hard questions.

My sincere thanks also goes to Dr. M. Sarkar, for offering me the opportunity to work in her research group at San Diego State University, CA, USA.

Many thanks to my fellow research colleagues, all teaching and non-teaching staffs of our department. It gives me a sense of happiness to be with you all.

A special thanks to my family. Words can not express how grateful I am to my father, mother, father-in-law and mother-in-law for all of the sacrifices that you have made on my behalf. Your prayer for me was what sustained me thus far. I would also like to thank my two lovely sisters and brother-in-laws for their unconditional support throughout my Ph.D. work. I would especially like to thank to rest of my family members who has helped me in a number of ways. Last, but not the least I would like to express appreciation to my beloved wife *Sarmistha* who spent sleepless nights with and was always my support in the moments when there was no one to answer my queries.

*Asis Kumar Tripathy*

# Abstract

Applications in wireless sensor networks (WSNs) span over various areas like weather forecasting to measuring soil parameters in agriculture, and from battlefield to health monitoring. Constrained battery power of sensor nodes make the network design a challenging task. Amongst several research areas in WSN, designing energy efficient protocols is a prominent area. Clustering is a proven solution to enhance the network lifetime by utilizing the available battery power efficiently. In this thesis, a hypothetical overview has been done to study the strengths and weaknesses of existing clustering algorithms that inspired the design of distributed and energy efficient clustering in WSN.

Distributed Dynamic Clustering Protocol (DDCP) has been proposed to allow all the nodes to take part in the cluster formation scheme and data transmission process. This protocol consists of a cluster-head selection algorithm, a cluster formation scheme and a routing algorithm for the data transmission between cluster-heads and the base station. All the sensor nodes present in the network takes part in the cluster-head selection process.

Staggered Clustering Protocol (SCP) has been proposed to develop a new energy efficient clustering protocol for WSN. This algorithm is aiming at choosing cluster-heads that ensure both the intra-cluster data transmission and inter-cluster data transmission are energy-efficient. The cluster formation scheme is accomplished by exchanging messages between non-cluster-head nodes and the cluster-head to ensure a balanced energy load among cluster-heads.

An energy efficient clustering algorithm for wireless sensor networks using particle swarm optimization (EEC-PSO) has been proposed to ensure energy efficiency by creating optimized number of clusters. It also improves the link quality among the cluster-heads with the cluster member nodes. Finding a set of suitable cluster-heads from  $N$  sensor nodes is considered as non-deterministic polynomial (NP)-hard optimization problem.

The application of WSN in brain computer interface (BCI) has been proposed to detect the drowsiness of a driver on wheels. The sensors placed in a braincap worn by the driver are divided into small clusters. Then the sensed data, known as EEG signal, are transferred towards the base station through the cluster-heads. The base station may be placed at a nearby location of the driver. The received data is processed to take a decision when to trigger the warning tone.

**Keywords:** wireless sensor network, clustering, energy efficiency, heterogeneity, electroencephalogram, brain computer interface, PSO.



# Contents

<b>Certificate of Approval</b>	<b>iii</b>
<b>Certificate</b>	<b>iv</b>
<b>Declaration</b>	<b>v</b>
<b>Acknowledgment</b>	<b>vii</b>
<b>Abstract</b>	<b>viii</b>
<b>List of Acronyms / Abbreviations</b>	<b>xiii</b>
<b>List of Figures</b>	<b>xiv</b>
<b>List of Tables</b>	<b>xvi</b>
<b>1 Introduction</b>	<b>1</b>
1.1 Applications of Wireless Sensor Networks . . . . .	3
1.2 Challenges of Wireless Sensor Networks . . . . .	4
1.3 WSN Implementation Requirements . . . . .	5
1.4 Clustering in Wireless Sensor Networks . . . . .	7
1.4.1 Distributed Clustering . . . . .	9
1.4.2 Energy Efficient Clustering . . . . .	9
1.5 Data Transmission in Clustered WSNs . . . . .	10
1.6 Clustering based on Particle Swarm Optimization (PSO) . . . . .	11
1.7 Brain Computer Interface . . . . .	12
1.8 Motivation . . . . .	13
1.9 Research Objectives . . . . .	14
1.10 Outline of the Thesis . . . . .	15
<b>2 Literature Review</b>	<b>17</b>
2.1 Clustering Scheme Overview . . . . .	18
2.1.1 History of Clustering . . . . .	19

2.1.2	Need of Clustering . . . . .	19
2.2	State-of-art of Clustering Algorithms . . . . .	20
2.3	Brain Computer Interface . . . . .	30
2.4	Summary . . . . .	34
<b>3</b>	<b>Distributed Dynamic Clustering Protocol for WSN</b>	<b>36</b>
3.1	Introduction . . . . .	37
3.2	Clustering Parameters . . . . .	39
3.3	System Model . . . . .	40
3.3.1	Notations . . . . .	40
3.3.2	Assumptions . . . . .	40
3.3.3	Energy Consumption Model . . . . .	41
3.3.4	Clusterhead Selection Mechanism . . . . .	42
3.4	The Proposed Distributed Dynamic Clustering Protocol (DDCP)	44
3.4.1	Work Flow of the Protocol . . . . .	44
3.4.2	Description of the Protocol . . . . .	45
3.4.3	Network Model . . . . .	46
3.4.4	Analysis of the Algorithm . . . . .	47
3.5	Simulation Results and Discussions . . . . .	49
3.5.1	Performance metrics . . . . .	49
3.5.2	Study 1: Efficiency with regard to percentage of advanced nodes ( $m$ ) . . . . .	50
3.5.3	Study 2: Robustness with regard to number of cluster- heads . . . . .	53
3.5.4	Study 3: Efficiency with respect to Network lifetime . . . . .	55
3.5.5	Study 4: Case study for the use of clustering in wireless Brain Computer Interface . . . . .	56
3.6	Summary . . . . .	56
<b>4</b>	<b>Staggered Clustering Protocol for WSN</b>	<b>58</b>
4.1	Introduction . . . . .	59
4.2	Problem Statement . . . . .	60
4.3	Proposed Solution to the Problem . . . . .	61
4.4	System Model . . . . .	61
4.4.1	Network Model . . . . .	61
4.4.2	Energy Model . . . . .	62
4.5	Clustering Parameters . . . . .	64
4.6	Proposed Staggered Clustering Protocol . . . . .	64
4.6.1	Description of the Protocol . . . . .	64
4.6.2	Cluster Head Selection Mechanism . . . . .	65
4.6.3	Analysis of Cluster Head Selection Mechanism . . . . .	66

4.6.4	Clustering Algorithm . . . . .	67
4.7	Analysis of the Algorithm . . . . .	70
4.8	Simulation and Result Discussion . . . . .	71
4.8.1	Study 1: Robustness with regard to numbers of clusters	72
4.8.2	Study 2: With respect to the number of data packets transmitted . . . . .	74
4.8.3	Study 3: With respect to energy consumption . . . . .	74
4.8.4	Study 4: Efficiency with respect to lifetime . . . . .	75
4.8.5	Case 5: Case study for the use of Clustering in Wireless Brain Computer Interface . . . . .	76
4.9	Summary . . . . .	77
<b>5</b>	<b>Energy Efficient Clustering Algorithm for Wireless Sensor Networks using Particle Swarm Optimization</b>	<b>79</b>
5.1	Introduction . . . . .	80
5.2	System Modeling . . . . .	81
5.2.1	Network Model . . . . .	82
5.2.2	Energy Model . . . . .	82
5.3	Particle Swarm Optimization . . . . .	83
5.4	The Proposed Protocol . . . . .	84
5.4.1	Cluster Formation Phase . . . . .	85
5.4.2	Data Communication Phase . . . . .	87
5.5	Simulation and Result discussion . . . . .	88
5.6	Summary . . . . .	92
<b>6</b>	<b>An Application of Wireless Brain Computer Interface for Drowsiness Detection</b>	<b>94</b>
6.1	Introduction . . . . .	95
6.1.1	System Model . . . . .	97
6.1.2	Wireless EEG Signal Acquisition Unit . . . . .	98
6.1.3	EEG Signal Processing Module . . . . .	99
6.2	Network Model . . . . .	100
6.2.1	Energy Dissipation Model . . . . .	101
6.2.2	Clustering Strategy . . . . .	101
6.3	Drowsiness Detection and Warning Process . . . . .	103
6.3.1	Alert Model . . . . .	104
6.3.2	Drowsiness detection algorithm . . . . .	105
6.4	Results and Discussions . . . . .	107
6.4.1	Experimental Results . . . . .	107
6.4.2	Drowsiness Detection . . . . .	109
6.5	Summary . . . . .	112

<b>7 Conclusions and Future Scope of Work</b>	<b>113</b>
7.1 Future scope of work . . . . .	115
<b>Dissemination</b>	<b>117</b>
<b>References</b>	<b>119</b>

# List of Acronyms/Abbreviations

CH	Cluster-head
BS	Base Station
WSN	Wireless Sensor Network
BAN	Body Area Network
WBAN	Wireless Body Area Network
DCP	Direct Communication Protocol
CTP	Collection Tree Protocol
LCA	Linked Cluster Architecture
RCC	Random Competition Based Clustering
TDMA	Time Division Multiple Access
CWSN	Clustered Wireless Sensor Network
BCI	Brain Computer Interface
EEG	Electroencephalogram
MAC	Media Access Control
CPU	Central Processing Unit
HWSN	Heterogeneous Wireless Sensor Network
ES	Embedded System
LEACH	Low Energy Adaptive Clustering Hierarchy
DWEHC	Distributed Weight Based Energy Efficient Hierarchical Clustering
HCA	Hybrid Clustering Approach
DECP	Distributed Election Clustering Protocol
EEHC	Energy Efficient Heterogeneous Clustered Scheme
EDFCM	Energy Dissipation Forecast and Clustering Management
EEUC	Energy Efficient Unequal Clustering
EECS	Energy Efficient Clustering Scheme
FLOC	Fast Local Clustering Service
MOCA	Multi-hop Overlapping Clustering Algorithm
PEGASIS	Power Efficient Gathering in Sensor Information System
PEACH	Power Efficient and Adaptive Clustering Hierarchy
WIBEEM	Wireless BCI EEG Electronics Module
ADAS	Advanced Driver Assistance System

# List of Figures

1.1	A Wireless Sensor Network . . . . .	2
1.2	An example of clustering . . . . .	8
1.3	Multi-hop communication in clustered WSN . . . . .	10
3.1	Radio Model . . . . .	41
3.2	Flow chart of the algorithm . . . . .	44
3.3	Wireless Sensor Network with 0.2 times advanced nodes . . . . .	52
3.4	Wireless Sensor Network with 0.5 times advanced nodes . . . . .	52
3.5	Efficiency based on percentage of advanced nodes . . . . .	53
3.6	Number of cluster-heads created for different protocols . . . . .	54
3.7	Lifetime comparison between different algorithms . . . . .	55
3.8	Lifetime of the algorithms on different simulation settings . . . . .	57
4.1	Network operation of the protocol . . . . .	68
4.2	Number of Cluster heads per round . . . . .	72
4.3	Amount of data packets received at the base station until the first node dies versus initial energy . . . . .	73
4.4	Amount of data packets received at the base station until half the nodes die versus initial energy . . . . .	73
4.5	Average energy dissipation of the network versus number of rounds	75
4.6	Lifetime of some selected algorithms . . . . .	76
4.7	Lifetime of some selected algorithms on different settings (reduced number of nodes) . . . . .	77
5.1	Number of Cluster-heads per round . . . . .	89
5.2	Average energy dissipation of the network versus number of rounds	90
5.3	Lifetime of the algorithms . . . . .	91
5.4	Lifetime of some selected protocols on different simulation settings	92
6.1	Photographs of (a)Wireless braincap used for signal acquisition (b) Signal processing module . . . . .	96
6.2	Working model of wireless BCI System . . . . .	98
6.3	Work flow of the algorithm . . . . .	104

6.4	Flowchart of drowsiness detection methodology . . . . .	106
6.5	Comparison based on number of data packets received at base station . . . . .	108
6.6	Lifetime comparison between different protocols . . . . .	109
6.7	Confusion matrix . . . . .	110
6.8	Receiver Operating Characteristics (ROC) for drowsiness detection . . . . .	111

# List of Tables

2.1	Summary of Clustering Algorithms in terms of strengths and weaknesses . . . . .	27
2.2	Summary of BCI Algorithms in terms of strengths and weaknesses	33
3.1	Notations . . . . .	40
3.2	Simulation parameters . . . . .	50
4.1	Simulation parameters . . . . .	71
5.1	Simulation parameters . . . . .	88
6.1	Simulation parameters . . . . .	108
6.2	Different parameters for drowsiness detection . . . . .	112



# Chapter 1

## Introduction

---

Wireless sensor network (WSN) research concentrates on working with small, modest, multi-functional sensor nodes that can sense, process, and communicate. WSNs have numerous confinements contrasted with Ad-Hoc networks regarding its sensor nodes' capability of memory storage, processing and the available energy source. These are light weight energy constrained devices that work with little limit DC source. The recharging or replacement of energy sources of the sensor nodes is sometimes difficult or even impractical.

WSNs can be applied to measure humidity, temperature, pollution levels, wind speed and direction, pressure, sound, vibration, and power [1, 2]. With the development of robotized devices and the advancement in wireless communications, it becomes easier to acquire information about the physical environment. Thus, the use of WSN has reduced the challenges met by the conventional method of measuring, processing, and communicating the data to a remote location. In any kind of WSN, these sensor nodes gather and agreeably send this gathered data to a remote base station. The major challenges of the sensor nodes are processing power constraints, battery power limitations, duplicate data gathering, and limited memory power of

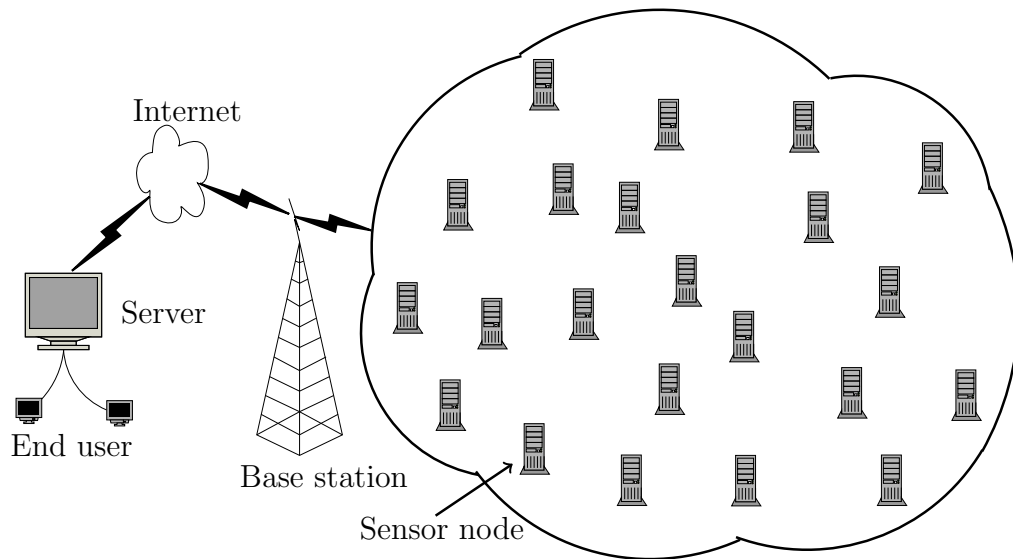

Figure 1.1: A Wireless Sensor Network

the network [3, 4].

A WSN comprises of spatially appropriated independent sensor nodes to agreeably sense physical or environmental conditions. These type of networks are fundamentally data collecting networks, where data are exceedingly associated for the end user [5, 6]. The deployed sensor nodes communicate wirelessly to the base station and often try to build a network. The general overview of a wireless sensor network is depicted in Figure 1.1. The WSN may comprise of hundreds or even more number of nodes, which provides reliable monitoring of any applications. The sensed data are transmitted to the base station directly or by a multi-hop fashion. The base station is connected to the wired world where the data can be collected in large databases for future use.

A WSN framework merely provides a communications infrastructure to existing sensors or standalone gadgets [7, 8]. Permitting different devices and machines to communicate with each other or with a centralized controller, improves the way of association with themselves.

## 1.1 Applications of Wireless Sensor Networks

Wireless Sensor Networks may comprise of various sorts of sensors, for example, seismic, thermal, visual, infrared, acoustic and radar. They find themselves able to monitor a broad range of surrounding conditions that incorporate humidity, temperature, lightning condition, vehicular movement, enemy's position and the speed, direction and size of an object.

**Military applications:** The fast organization, self-association and adaptation to non-critical failure qualities of a sensor network make them an extremely encouraging sensing procedure for military command, control and communication. The WSNs could be utilized to identify and receive as much data as could reasonably be expected about enemy positions, blasts and other activities. Where as, the network also helps in battlefield surveillance, atomic, natural and chemical attack recognition and monitoring.

**Healthcare applications:** Now-a-days the rising cost of healthcare applications influence the WSN researchers to invent the Body Area Sensor Networks (BAN) to provide better treatment at lesser cost. Body area sensor networks can be utilized to monitor physiological information of patients. The BANs can give interfaces for incorporated patient observing. The networks permit patients a more prominent opportunity of treatment and permit doctors to distinguish predefined symptoms prior on.

**Home applications:** With the development of innovation, the little sensor nodes can be implanted into furniture and appliances. For example, vacuum cleaners, microwave ovens and washing machines, etc. They find themselves able to correspond with one another and the room server to find out about the administrations they offer, e.g., cleaning, examining and washing. These tiny sensor nodes can be incorporated with existing installed gadgets to end up self-arranging, self-managed and versatile systems to frame a smart environment.

**Environmental applications:** WSN is widely used for environmental monitoring, which includes animal tracking and observing ecological

conditions that influence yields and animals. In case of environmental monitoring application long term monitoring is needed to get sufficient evidence to take a decision. Different uses of WSN are chemical and organic discovery, precision agriculture, woods fire recognition, volcanic checking and meteorological or geophysical exploration.

## **1.2 Challenges of Wireless Sensor Networks**

WSNs may contain hundreds or a large number of nodes that are deployed in an extensive region. These nodes are obliged to have the capacity to communicate with one another even without a built up network infrastructure. Besides, in spite of the fact that nodes in a wireless sensor network are fixed, the system topology is consistently changing because of dead nodes and fluctuating channel conditions. In this manner, the protocols used for the wireless sensor networks must have the capacity to manage proficiently network topology [9, 10]. What's more, WSNs are required to have the ability to keep up the execution without considering the size of the networks. That implies the execution of the network won't be influenced notwithstanding when the quantity of nodes is enormous. Consequently, scalability is an outline test for any kind of protocol used for the WSNs.

The sensor nodes have limited energy source. In the situations where the sensor nodes work in remote application areas, it might be difficult to recover the nodes to energize batteries. In this way, the network is relied upon to have a certain lifetime amid which nodes have adequate energy. This implies that the protocols for wireless sensor networks must be intended to be energy efficient. The protocols used for the WSNs ought to have the capacity to adjust the energy dissemination of nodes keeping in mind the end goal to maximize the network lifetime.

Different difficulties, for example, data quality and latency time influences the efficiency of the protocols used for the wireless sensor networks. These

challenges can be taken care of according to the requirement of specific applications.

### 1.3 WSN Implementation Requirements

So as to make these networks a reality, the node equipment and usage ought to be improved for three attributes:

- **Lesser cost:** The utility of the network relies on high density and universality, which implies vast quantities of nodes. In order to make huge scale deployments financially plausible, nodes must be very cheap.
- **Lesser power:** For the miniaturized nodes of WSN, the battery recharging/replacement is troublesome, costly, or even outlandish. Nodes should have the capability to function for long stretches without running out of power.
- **Real-time support:** In case of real time support data should be delivered without any delay. There are some of the applications which needs the real data instead of stored and forwarded data.

Each of these three elements is sort of intertwined. For instance, electronic segments are now so small that the general module size is limited by power supply or energy storage prerequisites. Hence, diminishing power utilization of the gadgets is a viable approach to shrink the size as well. An alternate case is that the use of integrated circuits with few external segments can at the same time diminish both size and cost. Among all the node capacities, for example, computation, sensing, and activation, the wireless communication energy is still a prevailing segment [11].

The sensor nodes present in a wireless sensor network are responsible for sending the sensed information to the base station. Those nodes may detect the real-time movement of animals, vehicles, etc. For the fast moving items,

the nodes have to monitor a slight change from the previous state. The base station needs to take few actions soon after getting the real time data from the member nodes. The wireless sensor networks may be used to detect the health conditions of the severely injured patients. In general, the member nodes forward the data to the collector node, which will again transmit the received data to a health awareness server. Then, the server checks the gathered data to take the decision of informing to the concerned doctors. To save a patient's life through WSN, it needs to receive the real-time data by the server [12].

The sensor nodes can communicate with the base station in two possible ways as described below:

- Direct Communication Protocol (DCP): In this type of communication, every sensor sends its information straightforwardly to the base station. In the event that the base station is far from the nodes, direct correspondence will oblige a lot of transmission energy from every node. This will rapidly deplete the battery of the nodes and decrease the network lifetime. In this method, the main gatherings in this protocol happen at the base station.
- Collection Tree Protocol (CTP): In a collection tree protocol the data is delivered to the cluster-heads, providing a many-to-one network layer characteristics. This protocol uses routing metrics to update and construct accumulation tree in the network. The CTP is intended for generally low traffic rates such that there is sufficient space in the channel to transmit and receive routing packets [13].

However, both the DCP and CTP suffers from its own drawbacks and do not solve the problem of energy efficiency. A proven solution is partitioning the nodes into virtual groups called *clusters*. Every cluster is associated with a cluster-head (CH) and few members. The process of sensing, aggregating and communication are done by the CH and members by mutually agreeable protocols.

## 1.4 Clustering in Wireless Sensor Networks

Clustering is the process of segregating the sensor nodes into virtual groups. Each one cluster is administered by a node called as cluster-head (CH) and different nodes are implied as member nodes. Clustered nodes don't communicate straightforwardly with the base station, but they need to transmit the gathered information through the cluster-head. The CH tries to aggregate the received data, received from the cluster members and forwards it to the BS. Thus, it minimizes the energy utilization and a number of messages imparted to the base station [14, 15]. Likewise, the communications traffic in the network is lessened. The amazing result of clustering the sensors in a network helps in extending the lifetime of the network. Clustering is the hierarchical procedure followed in a network, made to streamline the communication process of the network. It prompts the presence of an incredible number of task-specific clustering protocols [16, 17].

In clustering as shown in Figure 1.2, the nodes are divided into different clusters based on certain heuristics, where one cluster-head is present for each cluster. All the member nodes transmit data to their respective cluster-heads, where the cluster-head performs the data aggregation and forward to the base station. As the nearby nodes inside one cluster may sense the same data, the duplicate data can be eliminated at the cluster-heads by the data aggregation technique. Subsequently, it helps in energy saving and re-utilizing the bandwidth in the process of clustering [18, 19]. Additionally, clustering helps in settling the topology of the network and improves the versatility of the network [20].

The different entities present in a clustering process are:

**Cluster members:** These are the sensors deployed in the application area, which helps in building a clustered wireless sensor network. They are capable of sensing the real data and transmitting them towards the base station.

**Cluster Head:** There exists a virtual leader in each cluster, which are

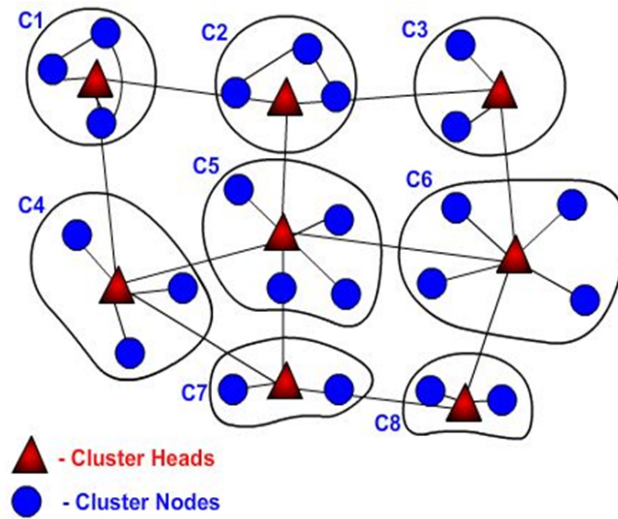

Figure 1.2: An example of clustering

designated as cluster-heads. In more, it is in charge of distinctive exercises done in the cluster, for example, data aggregation, data scheduling and data transmission to the CH.

**Base Station:** The base station is the primary data accumulation center for the wireless sensor network. This is considered as the bridge between the network and the end client. The BS regarded as having no resource constraints like bandwidth, battery power and processing capability.

Advantages of clustering are,

- Transmit aggregated information to the BS
- Lesser number of nodes involved in transmission
- Valuable Energy utilization
- Versatility for vast number of nodes
- Diminishes communication overhead
- Productive use of resources in WSNs



### 1.4.1 Distributed Clustering

The authors of Linked cluster algorithm (LCA) [21] initially proposed distributed clustering as linked cluster architecture for wireless networks. In distributed clustering process, there is no settled central CH for all time. The responsibility of being a CH focused around a few parameters, such as residual energy [22], the probability of becoming a cluster-head, degree of connectivity, etc. The responsibility of becoming a cluster-head is distributed amongst the sensor nodes as a federal structure [23]. A centralized clustering method is utilized as a part of a WSN and if the central node fails, the whole system will crumble and subsequently there is no certification for reliability in centralized clustering scheme. Thus, the unwavering quality of a WSN can be tremendously enhanced by utilizing distributed architecture [24, 25]. Distributed construction modeling is utilized as a part of WSNs for some particular reasons like sensor nodes inclined to failure and better gathering of information. Additionally, nodes sensing and sending the redundant data can be minimized. Since there is no central node to apportion the resources, they must act to be self-organized [26]. Concentrating on these anticipated favorable circumstances of distributed algorithms over centralized algorithms, a distributed clustering algorithm is talked about in this thesis with their parameters.

### 1.4.2 Energy Efficient Clustering

In WSNs, proficient utilization of node's energy by accomplishing best coverage of the terrain is a testing issue. Sensor nodes expend a lot of energy during transmitting and receiving. So, we need to shuffle the responsibility of being cluster-heads among the nodes present in the network. Due to the use of efficient algorithms for selection of cluster-heads, it is possible to diminish the energy utilization and enhance the network coverage proficiently. The cluster-heads utilize a lot of energy in transmitting or receiving data packets

from the member nodes, so it is important that the cluster-head won't be permitted to be a CH in the following round [27]. The use of sleep or listen states of the sensor nodes and the data aggregation strategies diminish energy utilization in the sensor networks. Motivated by the time division multiple access (TDMA), shutting down the radio, when it's not sending information bits, is a well known methodology to moderate energy in WSN [28, 29]. Energy-aware routing and clustering protocols additionally endeavor to lessen energy utilization and amplify the network lifetime by controlling specialized communication strategy over the network.

## 1.5 Data Transmission in Clustered WSNs

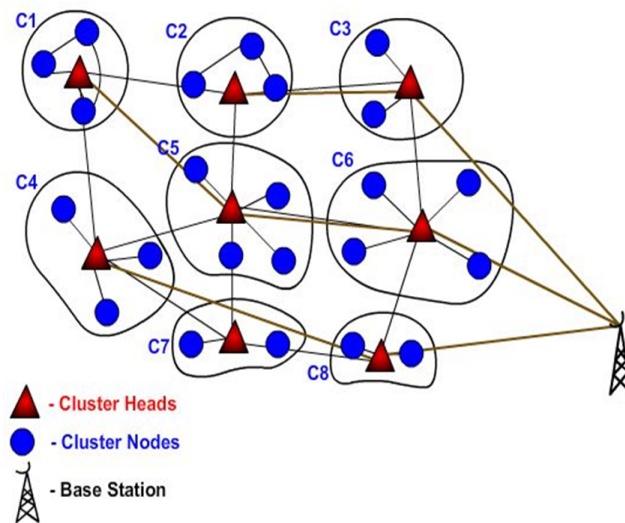

Figure 1.3: Multi-hop communication in clustered WSN

Cluster based data transmission in WSNs has been researched by researchers keeping in mind the end goal to attain the network scalable and manageable. This expands node lifetime and diminishes bandwidth consumption by utilizing nearby coordinated effort among sensor nodes [30, 31]. Data transmission in a clustered network can be possible in two ways, intra-cluster and inter-cluster communication.

The communication in between the members present inside a cluster is known as intra-cluster communication. The nodes found in the transmission range of each other within a cluster performs direct communication. Whereas, the nodes present outside the transmission region adopts multi-hop communication. In this way, the closer nodes do not have an additional load on them. In customary communication, the closer nodes to the cluster-head spend energy rapidly both for sensing and forwarding.

However, the communication between the cluster-heads with the base station is known as inter-cluster communication. In this type of communication, the CHs use IEEE 802.11 to send data to the base station. The cluster-heads combine a few data packets into one data packet that results in lessening energy overhead.

## **1.6 Clustering based on Particle Swarm Optimization (PSO)**

Clustering is one of the design methods used to manage the network energy consumption efficiently, by minimizing the number of nodes that take part in long-distance communication with the base station and distributing the energy consumption evenly among the nodes in the network. In this approach, each group of sensors has a cluster-head node that aggregates data from its respective cluster and sends it towards the base station as a representative sample of its cluster [32]. Therefore, the application of the clustering-based approach has the advantage of reducing the amount of information that needs to be transmitted, as well as enhancing resource allocation and bandwidth reusability.

The PSO algorithm is an evolutionary computing technique, modeled after the social behaviour of a flock of birds. In the context of PSO, a swarm refers to a number of potential solutions to the optimization problem, where

each potential solution is referred to as a particle. The aim of the PSO is to find the particle position that results in the best evaluation of a given fitness function [33]. In the initialization process of PSO, each particle is given initial parameters randomly and is flown through the multi-dimensional search space.

## 1.7 Brain Computer Interface

One of the important applications of WSN is the real time health monitoring by the implementation of a wireless body area network (WBAN). This could be a wearable WBAN or implantable WBAN. To monitor the signals of the brain, a wearable cap deployed with sensors could also be very useful. The sensors on the cap interfaces the brain with a computer for processing, creates a new paradigm called brain computer interface (BCI). In the course of recent times, the investigation of the BCI has got much emphasis rather than any other. BCI framework provides another way of communication from the brain to the computer. This framework measures neurological signals from the brain of the human, especially the electroencephalogram (EEG) signal is captured. Wireless BCI frameworks are intended to disentangle the human intention and produce orders to operate outer gadgets or computerized applications. This innovation permit humans with the new encounters that empower an immediate communication between the brain and the computers [34, 35].

With compact wireless BCI frameworks, different day-to-day applications are being worked on now. At the beginning of BCI researchers, playing video games and controlling the cursor movement were developed for the shake of crippled individuals. As of late, with becoming interest of the human being, wireless BCI systems is useful for entertainments too. Also, other researchers have used wireless BCI frameworks for intriguing newer applications, for example, focused on checking the biomedical status of the human [36], instructing mobile phone [37], and detecting drowsiness state of the drivers [38].

## 1.8 Motivation

The unusual properties specified above get to be difficulties to set up a sensor network. The key test for setting up and proper operation of WSN is to maximize the lifetime of the sensor network by minimizing the energy utilization.

In traditional distributed frameworks, a fixed number of cluster-heads is known to each node in the network. In this proposal, each node can go about as either a cluster-head or a member node, which inspires the requirement for efficient algorithms to choose CHs as per the network applications. A node just thinks about the CH, that is inside its reachable extent. It suggests that attaining to global objectives can't be ensured yet can be approximated through smart local decisions. At long last, a node may come up short in the event that its energy asset is drained, which propels the requirement for pivoting the cluster-head role among all nodes for burden adjusting.

Since from last few years a variety of changes have been made to the utmost energy necessity in WSN, as energy dispersal is more for wireless transmission and reception [39]. Numerous methodologies were focused at rolling out the improvements at MAC layer and network layer to minimize the energy dissipation. If the cluster-heads are appropriately chosen over the network and sufficient clusters are structured, it will help to reduce the dissemination of energy and would contribute to expand the lifetime of the network [40]. To handle with all the difficulties mentioned above clustering have been discovered the proficient solution.

In recent times, numerous conventional wired BCI frameworks are utilized by the researchers. In this manner, the application of BCI frameworks is hard to escape from laboratory research experiments. Wireless BCI frameworks are to dispose of the wire connection between the signal acquisition and the interpretation unit. The wireless transmission unit uses Bluetooth or Zigbee modules as per the application environment. Development of wireless BCI

frameworks is extraordinarily moved forward with the removal of the wired connections.

## 1.9 Research Objectives

The sole reason for this work is to discover the strategy that is distributed and more energy proficient. Wireless sensor networks are battery operated networks. Sensor nodes gather the data and pass them on to the network for further use, which connotes the significance of getting the real sensed data. The transmitting and receiving of data uses the greater part of the energy of the network. So for better operation and increase the lifetime of the network, distributed and energy consumption must be the primary factor of concern. In this thesis, new methods for clustering the sensor network were proposed by using distributed approach and energy saving method. At last, the application of the clustering algorithm is shown in the thesis as a model of brain computer interface (BCI) framework. In particular, the objectives are as follows:

1. To design and evaluate a distributed clustering algorithm for WSN, which outperforms the clustering algorithms of its type. It creates clusters without the help of any centralised base station.
2. To design and evaluate energy efficient clustering algorithm for WSN, by utilizing state-of-the-art energy consumption techniques. It offers a promising improvement over conventional clustering algorithms.
3. To design and evaluate an application of cluster based WSN in brain computer interface (BCI). Here, we have detected the drowsiness of the driver by using clustered wireless BCI.

## 1.10 Outline of the Thesis

This thesis is organized into six different chapters. Each chapter is discussed below in a nutshell:

### **Chapter 2: Literature Review**

This chapter integrates the key research efforts that are available in this field. Specifically, this chapter describes the shortcomings of existing state-of-art clustering techniques, communication methodologies and wired brain-computer-interface algorithms.

### **Chapter 3: Distributed Dynamic Clustering Protocol for WSN**

This chapter introduces a distributed clustering protocol for wireless sensor network. It increases the lifetime of the network by minimizing the number of control packets being transferred.

### **Chapter 4: Staggered Clustering Protocol for WSN**

This chapter introduces an energy efficient clustering protocol for wireless sensor network. It attempts to maintain the constraint of well balanced energy consumption in the network.

**Chapter 5: Energy Efficient Clustering Algorithm for Wireless Sensor Networks using Particle Swarm Optimization** This chapter, a distributed and PSO-based clustering protocol to create hierarchical cluster structure for the sensor nodes. The proposed energy efficient clustering algorithm using PSO (EEC-PSO) is trying to optimize the number of cluster-heads to minimize the energy consumption of the network.

### **Chapter 6: An Application of Wireless Brain-Computer Interface for Drowsiness Detection**

This chapter introduces a wireless brain-computer interface for drowsiness detection. A drowsy driver recognition framework is one of the potential applications of intelligent vehicle systems.

### **Chapter 7: Conclusions**

This chapter presents the conclusions drawn from the proposed work with

much emphasis on the work done. The scope for further research work has been discussed in the end.

The contributions made in each chapter are discussed in the sequel; which include proposed schemes, their simulation results, and comparative analysis.



# Chapter 2

## Literature Review

---

Wireless sensor networks are special kind of wireless networks due to its constraints and application specific characteristics. Consequently, WSNs pose different research challenges. In a wireless communication system, cost and other application specific issues affect the communication properties of the system. For example, radio communication in WSN is considered as low power and short range contrasted with some other wireless communication system [41, 42]. The system performance characteristics vary considerably in WSN even though the same fundamental principles of the wireless communication network are used in WSN [43]. Considering the fundamental differences between the wireless communication system, many issues have been identified and investigated. Major issues affecting the design and performance of the wireless sensor network are the following:

- i) Deployment strategy
- ii) Localization
- iii) Efficient medium access control
- iv) Database centric design

- v) Quality of service
- vi) Clustering for hierarchical routing
- vii) Intra-cluster and inter-cluster communication
- viii) Application of WSN

We have restrained ourselves to the study of last three issues of the wireless sensor network. This thesis concentrates mainly on clustering for hierarchical routing, efficient intra-cluster and inter-cluster communication and application of WSN.

## 2.1 Clustering Scheme Overview

During clustering, the sensor nodes of a WSN are isolated into diverse virtual groups. They are apportioned geologically nearby into the same cluster as per some set of guidelines. In clustering, sensor nodes work either as a cluster-head or a member node [44–46]. A CH serves as a local coordinator for its cluster, by performing data aggregation and inter-cluster transmission. The CHs can combine the data and send it to the server as a solitary packet, thus diminishing the overhead from packet headers. Clustering has preferences for 1) decreasing energy consumption and 2) enhancing bandwidth utilization. Most of the algorithm aim to extend the network lifetime by balancing energy consumption among nodes and by distributing the load among different nodes from time to time [47, 48]. During the reformation of clusters, the cluster-head is changed along with the members affiliated to it. Clustering helps in resource utilization and minimizes energy consumption in WSN. It also provides better throughput by decreasing the quantity of sensor nodes that join in long distance transmission [49, 50]. In WSN the essential concern is the energy proficiency so as to expand the utility of the network.

### 2.1.1 History of Clustering

The wireless sensor network is fragmented into disjoint sets of nodes by using the clustering algorithms. In a clustered network a hierarchical structure is followed by the member nodes, cluster-heads and the base station. Conventional algorithms start the clustering for sensor networks by using the centralized control and global data available about the nodes. The network traffic and time delay in a WSN actuated by the accumulation of substantial measure of information may be undesirable. The problem is like the minimum dominating set problem in graph theory.

Linked cluster architecture (LCA) [51] is proposed by Baker and Ephremides in 1981 to demonstrate the clustering algorithm for wireless networks. They have mainly focused on building the network that can support the mobility of the nodes. The problem of creating more number of clusters in LCA was refined in [52]. In [53], the researchers, have showcased the use of multimedia application in wireless ad hoc networks. However, the data delivery delay can be minimized by using clustering, where every cluster performs their duty independently. Initially random competition based clustering RCC [54] was designed for MANETs, but afterwards it is well suited for WSNs. In [55], Nagpal and Coore proposed CLUBS, which uses local communication to build efficiently groups amongst the computers.

### 2.1.2 Need of Clustering

Initially, because of the relatively large number of sensor nodes, it is hard to distinguish each sensor nodes and their sensed information [56]. These nodes require the framework to structure connection among themselves, which helps in creating clusters [57]. The cluster structure guarantees essential performance accomplishment in a WSN with an extensive number of sensor nodes. Clustering gives some immediate profits like spatial reuse of assets to increase the framework limit [58]. Clusters give execution

improvement in case of routing. The cluster-heads of the clusters typically structure a virtual spine for inter-cluster routing [59]. Clustering in WSNs is exceptionally difficult because of the inborn qualities that recognize these networks from different wireless networks [20, 60].

## 2.2 State-of-art of Clustering Algorithms

There exist several clustering algorithms in WSN.

Heinzelman *et al.* [18] proposed low-energy adaptive clustering hierarchy (LEACH), which is a standout amongst the most well-known clustering protocols for WSN. The data collection is bound together with characterized periods. The clusters are created based on the received signal quality and the cluster-heads work as a local coordinator to forward the data packets. The data processing tasks, such as data aggregation are performed locally by the cluster-heads. The clusters are created in this algorithm by distributed mechanism, where nodes settle on autonomous decisions with no centralized control. At first a node decides to be a CH with a probability  $p$  and shows its choice. Every non-CH node determines its cluster by picking the CH that can be reached utilizing minimum correspondence energy. The role of being a CH is turned periodically among the nodes of the cluster with a specific end goal to adjust the load. A node becomes a CH for the current rotation round if the number is less than the following threshold:

$$T(n) = \begin{cases} \frac{p}{1-p^{*(r \bmod \frac{1}{p})}} & \text{if } n \in N \\ 0 & \text{otherwise} \end{cases} \quad (2.1)$$

where  $p$  is the desired percentage of CH nodes in the sensor population,  $r$  is the current round number, and  $N$  is the set of nodes that have not been CHs in the last  $\frac{1}{p}$  rounds. However, it is not applicable to networks deployed in large regions.

Younis *et al.* [61] proposed a distributed clustering scheme known as

Hybrid Energy-Efficient Distributed Clustering (HEED). In this protocol, cluster-heads are chosen intermittently as indicated by a hybridization of the node residual energy and an optional parameter which is intra-cluster communication cost. It selects the cluster-head that has the highest residual energy. The cluster-heads are well distributed throughout the sensing area. Energy utilization is not thought to be uniform for all the nodes. In HEED, every node is mapped to precisely one cluster and can explicitly communicate with its CH. However, this algorithm manages a considerable measure of cluster-heads that complexes the routing tree required amid inter-cluster communication and hence restrain the information gathering latency.

Ding *et al.* [62] have proposed distributed weight based energy-efficient hierarchical clustering (DWEHC) to attain better cluster size such that, the minimum energy topology will be kept up. DWEHC makes no suspensions on the size and the density of the network. The weight is an element of the sensor's energy reserve and the nearness of the neighbors. In a network, the node with largest weight would be chosen as a CH and the remaining nodes get to be members. The number of levels in the hierarchy depends on the extent of the cluster and the minimum energy required to reach the CH. The process of becoming either one-hop or multi-hop node to reach CH proceeds until nodes settle on the most energy efficient intra-cluster topology. Regardless of a portion of the likenesses, there are numerous execution contrasts between DWEHC and HEED, for instance, clusters produced by DWEHC are all the more very much adjusted than HEED. However, this algorithm also uses a complicated routing methodology that consumes a lot of energy in intra-cluster communication.

Neamatollahi *et al.* [63] proposed hybrid clustering approach (HCA), a distributed clustering algorithm for wireless sensor networks. In HCA, clustering is not performed in each round, which happens in dynamic clustering algorithms. Furthermore, when the residual energy of a CH gets to be short of what a predefined quantity, it sets a particular bit in the TDMA

data packet to be sent to the BS. So that the BS will inform to all the nodes about the begin of clustering process toward the start of the following round. At that point, the BS sends a particular synchronization pulse to all the nodes. In the wake of getting the pulse, every node sets them up for re-clustering. However, the delay between the request for re-clustering time and the actual start of the process affects the performance of the network.

Wang *et al.* [64] proposed distributed election clustering protocol (DECP), to prolong the network lifetime of WSNs, where the CHs are elected based on residual energy and communication cost. This protocol meets expectations for two-level heterogeneous wireless sensor networks. In DECP, the cluster head election is a function of residual energy and communication cost. On the off chance that the energy is not balanced for all the nodes then the node with most astounding energy is considered for the determination of CH. DECP gives more load balance when contrasted with traditional protocols like LEACH and DWEHC. However, this protocol suffers from more energy utilization during intra-cluster and inter-cluster communication.

Gong *et al.* [65] proposed a distributed, multi-hop routing protocol with unequal clustering for WSNs to upgrade network lifetime. In this algorithm, the BS is spotted in the middle of the sensing field that brings about adjusting the energy utilization. Here, each node is associated with a cluster to abstain from sensing gaps. All the nodes have the same initial energy and a unique identifier (ID) at the beginning of the clustering process. This algorithm picks a node as cluster head among the sensors having more residual energy. However, it requires more memory to store the table containing the distance values of each node.

Dilip *et al.* [66] proposed an energy efficient heterogeneous clustered scheme (EEHC) for wireless sensor networks. It is focused around weighted election probabilities of every node to turn into a cluster-head according to the residual energy of each node. The algorithm begins the clustering process with the nodes present in the heterogeneous network, having a distinctive measure of

energy at the beginning. Here the researchers utilized three types of sensors used in the network, they are, super nodes, advanced nodes and normal nodes. The first improvement they have achieved to the current LEACH is to expand the lifetime of the sensor network by minimizing the energy utilization. Super nodes are furnished with  $\beta$  times and advanced nodes are  $\alpha$  times more energy than the normal nodes, where  $\alpha$  and  $\beta$  are constants. EEHC has expanded the lifetime of the network by 10% as contrasted with LEACH in the vicinity of same setting of capable nodes in a network. However, this protocol suffers from storing of complicated route information by using all the three types of nodes.

Zhou *et al.* [67] proposed energy dissipation forecast and clustering management (EDFCM), which gives longer lifetime and more dependable transmission administration. The cluster-head selection in EDFCM is focused on a technique for on-stage energy utilization estimate. Furthermore, the management nodes assume a helpful part at present the determination of CHs to verify that the quantity of cluster-heads in every round is ideal. The algorithm tries to adjust energy utilization round by round, which will give the longest steady period to the networks. However, it uses energy consumption statistics of the previous round that requires a lot of calculation.

Li *et al.* [68] proposed energy-efficient unequal clustering (EEUC) protocol for periodical data gathering application in WSNs. The hot spot issue which emerges in multi-hop routing is evacuated in this algorithm. The problem arises when the CHs nearer to the base station dies because of the trouble by substantial relay traffic. To tackle this sort of issue researchers picked the clusters closer to the base station are required to have smaller cluster sizes. Along these lines, they will devour less energy amid the intra-cluster correspondence, and can protect some more energy for inter-cluster transfer activity. However, this protocol suffers from calculating the location of the cluster-head is troublesome.

Qing *et al.* [69] proposed a distributed multilevel clustering algorithm for

heterogeneous wireless sensor networks. Here the cluster-head is chosen by a likelihood focused around the proportion of the residual energy present at every node and the average energy of the network. The lifetime of a cluster-head is decided by the ratio of initial energy and residual energy. So dependably the nodes with high residual energy have more opportunity to turn into a CH. However, this algorithm suffers from deciding the cluster-head election threshold used during clustering procedure.

Ye *et al.* [70] proposed energy efficient clustering scheme (EECS), which helps in periodical data gathering applications of WSN. EECS algorithm is based on the gimmicks of most popular clustering algorithm LEACH. This algorithm chooses the cluster-head from the sensor nodes having more residual energy. It tackles the issue of even conveyance of cluster heads all through the sensing zone. Toward the starting, the candidate nodes contend among themselves to turn into a cluster-head. This algorithm uses single-hop communication between the CH and base station. During cluster formation the BS broadcasts a ‘hello’ message to all the nodes at a certain power level. In the wake of getting ‘hello’ message the nodes can figure the approximate distance to the BS focused around the received signal strength. However, it continuously monitors the energy level of the cluster-heads that requires a lot of energies.

Demirbas *et al.* [71] proposed a distributed clustering algorithm known as Fast Local Clustering service (FLOC). It delivers the clusters with pretty nearly equivalent size, which keeps up the overlapping as less as would be prudent. In FLOC, all sensor nodes are within unit separation from the cluster-head. Here the researchers have proposed another clustering property known as solid-disc property, which implies minimization of overlap. This property chooses all the nodes inside a unit distance from the cluster-head belongs to the same cluster. However, it requires a lot of attention during deployment to have unit distance sensor nodes to build equal size clusters.

Banarjee *et al.* [72] proposed a distributed hierarchical clustering algorithm for multi-hop wireless networks. The algorithm works based on certain



properties, for example, cluster size and the level of overlap. Every node present in that network joins the lowest layer in the hierarchy. The cluster-heads join the immediate next layer furthermore a few clusters are formed. The researchers expected that the topology changes in wireless sensor networks would be moderate and infrequent to implement this sort of algorithm. However, this algorithm suffers from the unnecessary use of energy to place different nodes in the different hierarchy.

Zhang *et al.* [73] proposed a distributed clustering algorithm for self-configuring and self-healing multi-hop wireless sensor network. Here the overlapping between the neighboring nodes is less, as a result of the cellular hexagonal structure of the nodes with range  $R$ . To attain to geographical clustering in expansive scale networks, the researchers attempted to bound the network with some predefined span of the cells. It utilizes extensive range for the hexagons to lessening energy utilization and unwavering quality for intra-cell correspondence. Self-healing property of the algorithm confirms the node join, node leave, node movement and node crash in the network. However, this algorithm suffers from collecting local information continuously to run the clustering algorithm.

Youssef *et al.* [74] proposed Multi-hop Overlapping Clustering Algorithm (MOCA) for wireless sensor network. Here the researchers contended that they will make the clusters overlapped to encourage numerous applications, for example, inter-cluster routing, topology revelation, node localization and recovery from cluster-head failure. In this algorithm, each node is either a cluster-head or inside  $k$ -hop separation from at least one CH, where  $k$  is a predefined estimation of cluster radius. However, the gateway nodes used in this algorithm are prone to failure because of the communication from the overlapped clusters.

Wang *et al.* [75] proposed a distributed clustering algorithm for WSN, which is based on the hierarchical approach. It actualizes cluster-head failure recovery and load balancing among cluster members. This practically

controlled hierarchical algorithm gives preferable result over flooding. Because of the idea of attribute based clustering, we can specifically contact that particular node rather flooding to the entire network. The proposed algorithm works indicated by the important attributes that can be abused to decrease unnecessary traffic. However, detecting the failure of the cluster-heads at real time is troublesome.

Yi *et al.* [16] proposed Power-Efficient and Adaptive Clustering Hierarchy (PEACH) protocol for wireless sensor networks. It is a versatile, hierarchical, scalable and power efficient clustering protocol. Clusters are shaped without any overhead in cluster-head choice. It can be pertinent in both location-unaware and locationaware WSNs. In this algorithm, there is no overhead for promoting about CH and to join cluster-heads. This algorithm operates on probabilistic energy-aware routing protocols like EAR, EAR-DPS, GEAR. However, this algorithm uses the location information of each node that requires a lot of storage area.

Sing *et al.* [76] proposed a new algorithm named as energy-efficient homogeneous clustering algorithm for wireless sensor networks. The lifetime of the network is expanded in this algorithm by using homogeneous sensor nodes. Efficiency and throughput of the network are enhanced due to the selection of cluster heads on the premise of residual energy and the nearest hop count of the node. However, the researchers trying to restrict the number of nodes for a cluster, which is very much difficult.

Norouzi *et al.* [77] proposed a new clustering protocol for WSN using genetic algorithm approach. They are trying to increase the lifetime by optimizing the energy consumption in a network. These two contending targets have a profound impact on the administration capability of networks. As per late studies, cluster development is a fitting answer to the above issue. They have utilized Genetic Algorithm (GA) as an element system to discover an ideal number of cluster-heads. However, the algorithm suffers from training the network with real world problems is almost impossible.

An energy-aware clustering for WSNs using PSO algorithm (PSO-C) is a centralized clustering protocol implemented at the BS [32]. It considers both energy available to nodes and physical distances between the nodes and their CHs. This protocol defines a cost function which tries to minimize both the maximum average euclidean distance of nodes to their associated CHs and the ratio of total initial energy of all nodes to the total energy of the CH candidates. It also ensures that only nodes with sufficient energy are selected as CHs. PSO-C outperforms both LEACH and LEACH-C in terms of the network lifetime and the throughput.

Elhabyan *et al.* [32] proposed a novel centralized PSO protocol for Hierarchical Clustering (PSO-HC) in WSNs. They tried to maximize the network lifetime by minimizing the number of active CHs and to maximize the network scalability by using two-hop communication between the sensor nodes and their respective CHs. The effect of using a realistic network and energy consumption model in cluster-based communication for WSN was investigated. Extensive simulations show that PSO-HC outperforms the well-known cluster-based sensor network protocols in terms of average consumed energy and throughput.

Table 2.1 summarizes the existing clustering protocols of WSN in terms of its strengths and weaknesses.

Table 2.1: Summary of Clustering Algorithms in terms of strengths and weaknesses

<i>Algorithm</i>	<i>Pros</i>	<i>Cons</i>
Younis <i>et al.</i>	(i) Balanced clusters (ii) Low message overhead	(i) Repeated iterations complexes algorithm (ii) Decrease of residual energy forces to iterate the algorithm.
Heinzelman <i>et al.</i>	(i) Uniform node distribution (ii) Inter-cluster communication using TDMA	(i) Energy depletes quickly (ii) CHs selected based on probability

Continued on Next Page. . .

Ding <i>et al.</i>	<ul style="list-style-type: none"> <li>(i) Hierarchical clusters.</li> <li>(ii) Inter-cluster communication using TDMA.</li> </ul>	<ul style="list-style-type: none"> <li>(i) Calculating weight is difficult.</li> <li>(ii) Algorithm is implemented by each node.</li> </ul>
Neamatollahi <i>et al.</i>	<ul style="list-style-type: none"> <li>(i) Clustering is not performed in each round.</li> <li>(ii) Cluster formation is on-demand.</li> </ul>	<ul style="list-style-type: none"> <li>(i) Continuous evaluation on CH's energy level also spends energy.</li> <li>(ii) Reclustering starts at the beginning of the next round.</li> </ul>
Wang <i>et al.</i>	<ul style="list-style-type: none"> <li>(i) Removes flooding in algorithm.</li> <li>(ii) Globally unique identifier for each node.</li> </ul>	<ul style="list-style-type: none"> <li>(i) Excess memory needed to store the energy level.</li> <li>(ii) CH selection process is complicated.</li> </ul>
Gong <i>et al.</i>	<ul style="list-style-type: none"> <li>(i) Sensing holes are avoided.</li> <li>(ii) BS is located at the center, to balance energy consumption.</li> </ul>	<ul style="list-style-type: none"> <li>(i) Calculating the distance based on received signal strength.</li> <li>(ii) More memory required to store the table containing the distance values of each node.</li> </ul>
Dilip <i>et al.</i>	<ul style="list-style-type: none"> <li>(i) Use of three types of nodes.</li> <li>(ii) Extends lifetime because of advanced nodes.</li> </ul>	<ul style="list-style-type: none"> <li>(i) Calculation of weight is difficult.</li> <li>(ii) Finding the spatial density.</li> </ul>
Zhou <i>et al.</i>	<ul style="list-style-type: none"> <li>(i) Provides longer lifetime.</li> <li>(ii) CHs per round is optimum.</li> </ul>	<ul style="list-style-type: none"> <li>(i) Uses energy consumption statistics of the previous round.</li> <li>(ii) Requires more memory to store the previous data.</li> </ul>
Li <i>et al.</i>	<ul style="list-style-type: none"> <li>(i) Removes the hot-spot problem.</li> <li>(ii) CH chooses a relay node from its adjacent nodes.</li> </ul>	<ul style="list-style-type: none"> <li>(i) Location of the CH is precomputed.</li> <li>(ii) Each node calculates their distance from the BS.</li> </ul>
Qing <i>et al.</i>	<ul style="list-style-type: none"> <li>(i) Role of CH is rotated among the nodes.</li> <li>(ii) All nodes have the idea of total energy and lifetime of the network.</li> </ul>	<ul style="list-style-type: none"> <li>(i) Repeated iterations complexes algorithm</li> <li>(ii) Deciding the election threshold is very difficult.</li> </ul>

Continued on Next Page...

Ye <i>et al.</i>	<ul style="list-style-type: none"> <li>(i) CH is elected based on local radio communication</li> <li>(ii) It uses single hop communication between CH and BS.</li> </ul>	<ul style="list-style-type: none"> <li>(i) Distance from BS is calculated at each node.</li> <li>(ii) Always checks for another node having more residual energy.</li> </ul>
Demirbas <i>et al.</i>	<ul style="list-style-type: none"> <li>(i) Non-overlapping clusters</li> <li>(ii) Clustering is done in constant time regardless of the network size.</li> </ul>	<ul style="list-style-type: none"> <li>(i) Designing equal size clusters.</li> <li>(ii) Double band nature of the wireless radio model is exploited.</li> </ul>
Banarjee <i>et al.</i>	<ul style="list-style-type: none"> <li>(i) Clusters are defined as subset of vertices.</li> <li>(ii) Created desired number of clusters.</li> </ul>	<ul style="list-style-type: none"> <li>(i) All sensors deployed will be identical.</li> <li>(ii) Nodes only can join to the lower layer.</li> </ul>
Zhang <i>et al.</i>	<ul style="list-style-type: none"> <li>(i) Nodes are self configurable.</li> <li>(ii) Dynamic change of number of nodes don't affect the performance.</li> </ul>	<ul style="list-style-type: none"> <li>(i) Local information is used for clustering.</li> <li>(ii) Higher number of control messages.</li> </ul>
Youssef <i>et al.</i>	<ul style="list-style-type: none"> <li>(i) Randomized distributed multi-hop clustering.</li> <li>(ii) Overlapping of clusters.</li> </ul>	<ul style="list-style-type: none"> <li>(i) Gateway nodes prone to failure.</li> <li>(ii) Cluster head probability is used.</li> </ul>
Wang <i>et al.</i>	<ul style="list-style-type: none"> <li>(i) CH elected based on residual energy and communication cost</li> <li>(ii) Load balanced compared to other algorithms.</li> </ul>	<ul style="list-style-type: none"> <li>(i) More use of computational power to calculate the communication cost.</li> <li>(ii) Repeated iterations complexes the algorithm.</li> </ul>
Yi <i>et al.</i>	<ul style="list-style-type: none"> <li>(i) Supports adaptive multi-level clustering.</li> <li>(ii) Minimizes energy consumption of each node.</li> </ul>	<ul style="list-style-type: none"> <li>(i) All sensor nodes have equal capabilities.</li> <li>(ii) Links are symmetric.</li> </ul>
Sing <i>et al.</i>	<ul style="list-style-type: none"> <li>(i) Homogeneous distribution of nodes.</li> <li>(ii) Efficient use of scarce resources at individual sensor nodes.</li> </ul>	<ul style="list-style-type: none"> <li>(i) Restricts the number of nodes in the cluster.</li> <li>(ii) CHs depletes energy very quickly.</li> </ul>

Continued on Next Page...

Norouzi <i>et al.</i>	<ul style="list-style-type: none"> <li>(i) Finds optimum number of CHs.</li> <li>(ii) Uses genetic algorithm to select clusters.</li> </ul>	<ul style="list-style-type: none"> <li>(i) Training the network is difficult.</li> <li>(ii) Multiple communication between CHs.</li> </ul>
Latiff <i>et al.</i>	<ul style="list-style-type: none"> <li>(i) Optimizes number of CHs and distance from node to CH.</li> <li>(ii) Lifetime is enhanced.</li> </ul>	<ul style="list-style-type: none"> <li>(i) Clustering is done by the BS.</li> <li>(ii) Duplicate candidate nodes present.</li> </ul>
Elhabyan <i>et al.</i>	<ul style="list-style-type: none"> <li>(i) Optimizes number of CHs and RSSI.</li> <li>(ii) Average energy consumption is minimized.</li> </ul>	<ul style="list-style-type: none"> <li>(i) Clustering is performed centrally by the BS.</li> <li>(ii) Uses multi-hop communication.</li> </ul>

## 2.3 Brain Computer Interface

Brain-Computer Interface (BCI) innovation is another quick advancing field that looks for direct cooperation between the human neural framework and machines. It plans to enlarge human abilities by empowering individuals (particularly disabled) to impart and control gadgets through wired or wireless communication. In the brain, networks of neurons structures input loops in charge of the oscillatory movement recorded in the EEG. BCIs are the main intends to gather user data through direct measures of brain activity ordinarily as a result of EEG signals. A BCI framework is just to translate EEG signals from an impression of brain activity into client action through framework's equipment and software. BCI methodologies are in light of a variety of strategies to create control signals that may be the aftereffect of auditive or visual incitement or imaginary motor tasks. For example, the paralyzed patients can not operate objects or communicate their needs, even though their mental capabilities are integral. Past studies have proposed different strategies to find drowsy driving by concentrating on blink rate, eye

closure, and inclination of driver's head.

Lin *et al.* [78] proposed a real-time wireless electroencephalogram (EEG) based braincomputer interface (BCI) system for drowsiness detection. Real-time drowsiness monitoring can avoid traffic accidents successfully. The work comprises of a wireless physiological signal acquisition module and an embedded signal processing module. Here, the physiological signal acquisition module and embedded signal processing module were intended for long-term EEG monitoring and real-time drowsiness detection, respectively. However, this methodology uses the headband to collect EEG from the brain, which receives less amount of signals as compared to the use of braincap.

Filipe *et al.* [79] designed a wireless multichannel data acquisition system for electroencephalography (EEG) recording. The WIBEEM (Wireless BCI EEG Electronics module) platform is being worked on and will be a wearable device for wireless 32-channel EEG recording. The outline of the WIBEEM platform considers all the imperatives of a wearable medical device: ultra-low power, scaling down, safety and reliability. However, the RF model used in this system only suits the medical application. So, it can only solve the problem for one type of users.

Hong and Qin [80] proposed an efficient method to solve the problems for eye state identification of drivers' for drowsiness detection. It tackles the issue by utilizing image processing methods. The essential spotlight on measuring physical changes of the driver, for example, eye blinking measures and size of the eye to distinguish drowsiness and alert the driver before meeting an accident. However, it requires a lot of computation by detecting the face of a person and the eye feature will be extracted to detect drowsiness.

Lin *et al.* [81] proposed a novel and simple technology to incorporate interactivity value in a BCI system to control an electric wheelchair. The BCI framework will be developed to permit correspondence between human and machine. At that point, it supplies a continuous interpretation of brain

and eye-blinking waves into a command like “start”, “moving forward”, or “stop” to control the wheelchair. In this system, they used the NeuroSky’s headset MindSet to capture EEG and eye blinking signals. However, it captures the EEG and eye-blinking wave from the forehead only, which uses less number of data items for controlling the wheelchair.

Ji *et al.* [82] proposed a real-time online prototype driver fatigue monitor, which utilizes remotely placed charge-coupled-device cameras furnished with dynamic infrared illuminators to acquire video images of the driver. A probabilistic model is used to model human fatigue and to predict exhaustion focused on the visual signals obtained. The multiple visual signals and their systematic combination yields a substantially more powerful and exact fatigue characterization than utilizing a single visual signal. However, it suffers from the problem of capturing real time video during driving.

Flores *et al.* [83] proposed a new Advanced Driver Assistance System (ADAS) for automatic driver’s drowsiness detection based on visual information and artificial intelligence. The point of this algorithm is to place and to track the face and the eyes to figure a drowsiness list. This framework uses advanced technologies for examining and checking driver’s eye state at real-time and genuine driving conditions. However, use of an optical flow algorithm for visual information based on artificial intelligence methods makes the system complex.

Eskandarian *et al.* [84] described an experimental analysis of commercially licensed drivers who were subjected to drowsiness conditions in a truck driving simulator. They likewise assessed the execution of a neural network based algorithm that monitors just the drivers’ steering data. The execution of the drowsy driver detection framework for truck drivers was like different structures that recognized drowsiness in passenger car drivers. However, it only uses driver’s steering input to make a decision on drowsiness detection.

Table 2.2 summarizes the existing work on BCI in terms of their strengths



and weaknesses.

Table 2.2: Summary of BCI Algorithms in terms of strengths and weaknesses

<i>Algorithm</i>	<i>Pros</i>	<i>Cons</i>
Lin <i>et al.</i>	<ul style="list-style-type: none"> <li>(i) Detects human cognitive state and provide biofeedback to the driver.</li> <li>(ii) Requires low power consumption and small volume.</li> </ul>	<ul style="list-style-type: none"> <li>(i) By using head band it doesn't collect EEG from all part of the brain.</li> <li>(ii) Same alertness model is used for all drivers.</li> </ul>
Filipe <i>et al.</i>	<ul style="list-style-type: none"> <li>(i) Wireless low power 32-channel data acquisition system is used.</li> <li>(ii) Different submodules are validated.</li> </ul>	<ul style="list-style-type: none"> <li>(i) The RF model only suits medical applications.</li> <li>(ii) Micro-controller module is highly complicated.</li> </ul>
Hong <i>et al.</i>	<ul style="list-style-type: none"> <li>(i) Eye state identification for detection of drivers' drowsiness.</li> <li>(ii) An object tracking method is used to keep track of the eyes.</li> </ul>	<ul style="list-style-type: none"> <li>(i) Eyes location can be identified with erect face by face detection.</li> <li>(ii) Face detection requires more computation.</li> </ul>
Lin <i>et al.</i>	<ul style="list-style-type: none"> <li>(i) It is a low cost and easy control with attention and eye-blinking.</li> <li>(ii) Simple unipolar electrode was used to capture EEG.</li> </ul>	<ul style="list-style-type: none"> <li>(i) EEG captured from the forehead only.</li> <li>(ii) The central control unit (CCU) may give wrong instructions.</li> </ul>
Ji <i>et al.</i>	<ul style="list-style-type: none"> <li>(i) Human fatigue is detected based on the visual cues.</li> <li>(ii) It is reasonably robust, reliable, and accurate in fatigue characterization.</li> </ul>	<ul style="list-style-type: none"> <li>(i) Real-time acquisition of video during driving may not give accurate result.</li> <li>(ii) Requires complex hardware for making it non-intrusive.</li> </ul>
Flores <i>et al.</i>	<ul style="list-style-type: none"> <li>(i) Drowsiness detection based on visual information and artificial intelligent.</li> <li>(ii) Based on the position of face and eye drowsiness index is computed.</li> </ul>	<ul style="list-style-type: none"> <li>(i) Use of optical flow algorithm over eyes and head is difficult.</li> <li>(ii) Classification amongst open and closed state of the eye is complex.</li> </ul>

Continued on Next Page . . .

Eskandarian <i>et al.</i>	<p>(i) Unobtrusive drowsiness detection methods can avoid catastrophic crashes.</p> <p>(ii) A trained ANN is used for detection.</p>	<p>(i) It monitors only the drivers' steering input.</p> <p>(ii) Calculation of subjective drowsiness rating is difficult.</p>
---------------------------	--	--

## 2.4 Summary

It has been observed from the literature study that quite a good number of clustering schemes have been proposed till date. However, the existing schemes are expensive from communication, energy, and time perspectives. The shortcomings of present clustering techniques are as follows.

- In the majority of existing works handshaking messages are sent as a routine task of a WSN. This increases energy and communication overhead.
- More research is yet to be done on energy efficiency.
- Most of the techniques do not optimize the number of clusters.
- Less amount of work has been done by using heterogeneous nodes.
- The clustering algorithms need to be application specific.

This provides a motivation for designing distributed, energy efficient clustering algorithms that could reduce the maintenance overhead as well as could increase the cluster stability.

Recently, the brain computer interface (BCI) has gained a lot of research interest for health monitoring, safety management and security in public places, etc. Understanding the brain signals for various human activities may save a lot of resources and human life. Use of BCI for drowsiness detection of a person on the wheel is one of them. Most of the existing schemes on BCI

are wire based. Due to the need of wire connectivity the object has to be static. So it forces the person to stay nearer to the computer that processes the brain signals. This motivated us to go for wireless BCI, where the person can move comfortably while communicating to the base station efficiently. In previous studies, we found that the wireless sensors used in BCI system makes direct communication with the data processing center. Furthermore, to increase the lifetime of each sensor node by spending less amount of energy in data transmission we have used the clustering mechanism even if we have less number of sensors. In case of clustered BCI, the sensors present on the braincap sends data to the respective cluster-head and then the data will be forwarded to the data processing center by the CH. In this way, we have tried to minimize the long distance communication from all the sensors participating in the BCI system.

## Chapter 3

# Distributed Dynamic Clustering Protocol for WSN

---

(Shows the effectiveness of distributed clustering approach)

## 3.1 Introduction

The broad utilization of wireless sensor networks (WSNs) in differing applications, forced the end users to feel the unreachable places as accessible areas. Primarily, WSN relies on upon correlated information, which are gathered by the network. These networks allude to a substantial number of scattered and dynamic sensors for checking and recording the sensing environment. The collected information are stored at a central location with the goal that they can be used afterward. The sensor nodes arrange themselves as an intermediate node when the end clients are at far distance. WSNs need to satisfy the simplicity of deployment, greater lifetime, and lower latencies data exchanges [46, 85–87].

The WSN confronts distinctive challenges, like storage constraints, computational limitations, and restricted power supply. Due to the deployments at unreachable territories and contaminated situations, where central monitoring is more troublesome or even impossible, the requirement for distributed mechanisms occurs [88]. In general the sensor nodes are less mobile, constrained with processing abilities and transmission capacity. Nonetheless, transmitting or receiving information and query processing influences the distributed algorithms in the sensor network [89, 90]. To minimize the direct correspondence from every sensor to the base station (BS) the distributed clustering procedure is presented in this chapter.

In clustering, a portion of the nodes are chosen as cluster-heads which will correspond with the BS for the individuals connected with it. On account of which the energy utilization can be minimized, and the network lifetime can be expanded by dispersing the role of CH among distinctive nodes. Grouping sensor nodes into clusters has been widely pursued by the research community in order to achieve the network scalability objective. In WSNs, clustering is performed to achieve the critical design goals like network

longevity and coverage of the sensing area [91, 92]. During communication, the CH nodes are over-burden with the long range correspondence with the base station. The CHs oblige additional processing for data aggregation, which brings about earlier lapsing of nodes. One critical way to pivot the role of a CH amongst all the sensor nodes has been indicated in low-energy adaptive clustering hierarchy (LEACH) [39], power efficient gathering in sensor information systems (PEGASIS) [93], and hybrid energy efficient distributed clustering (HEED) [61]. These protocols have been proved for indicating poor performance in heterogeneous environment. That is the fact that, the low-energy nodes will die more rapidly than the high-energy ones. The data aggregation performed at the cluster-heads pulls in a massive decrease in the measure of overhead for sending a lot of data packets to the BS. This is the motivation behind developing distributed heterogeneous wireless sensor network.

After clustering is done, every sensor node transmits data with a selected time space allocated by the cluster-head by using time-division multiple access (TDMA) methodology [94]. In numerous existing algorithms, cluster association fundamentally reliant on a gathering of spatially closed sensor nodes. In centralized clustering protocols, the BS or any central agent is held responsible for the clustering procedure by using the global information in the network [95]. Whereas, in distributed clustering each node takes part in choosing cluster-heads with the knowledge of neighborhood data instead of global data.

The proposed distributed dynamic clustering protocol (DDCP) lives up to expectations in conjunction with the primary clustering protocol and adventures the dynamic change of cluster-head responsibilities. A choice about the distributed condition of a network is taken in light of the power decentralization among the nodes. This is because of the agreement on the quantity of one-hop neighbors of a sensor node to build the network. We

have modeled a distributed algorithm for a wireless sensor network to outperform other algorithms of its type.

The rest of the chapter is organized as follows. Section 3.2 presents the clustering parameters. The system model is presented in Section 3.3. The proposed algorithm is described in Section 3.4. Where as Section 3.5 presents the simulation results and discussion of the algorithm. Finally, Section 3.6 summarizes the chapter.

## **3.2 Clustering Parameters**

In clustering, the sensor nodes are partitioned into distinctive virtual groups, as indicated by the spatially closed sensors. In clustered environment, the sensor nodes are allotted with any of the two roles, either a cluster-head (CH) or a cluster member. The duty of the CH is to play as a neighborhood coordinator for its group, which performs intra-cluster transmission plan and data forwarding. The CH aggregates the received data and sends it to the base station as a single packet.

Clustering in WSN reduces the use of both useful and inefficient energies by enhancing bandwidth utilization and diminishing overhead separately. The lifetime of the network can be extended by dispersing the load of being CH among diverse nodes. Amid the transformation of clusters, the responsibility of cluster-head is changed dynamically, alongside the members partnered to it. The multi-hop communication process decreases the long distance transmission in a network. In a clustered network, the expense is computed in light of intra and inter-cluster communication cost. The proposed algorithm is a well-balanced distributed protocol that upgrades lifetime of the heterogeneous wireless sensor network. It is a heuristic based algorithm that select the CHs based on the number of neighbors and the amount of energy left with each node.

## 3.3 System Model

### 3.3.1 Notations

The list of the notations used in this chapter and their meanings are shown in Table 3.1.

Table 3.1: Notations

Symbols	Meaning
$N$	Number of sensor nodes.
$n_c$	Number of cluster heads.
$v_i$	Sensor node.
$r$	Radio range of sensor node
$x_i$	Sensor reading at node $v_i$ .
$S(v_i)$	One-hop neighbor set of $v_i$ .
$R_{Tx}$	Transmission range.
$E_{Tx}$	Energy spent in transmitting one bit.
$E_{Rx}$	Energy spent in receiving one bit
$E_{DA}$	Energy spent in aggregation of data.
$E_{elec}$	Per bit electronics energy.

### 3.3.2 Assumptions

The following assumptions are considered for the algorithm:

- a) The nodes of the WSN are deployed by random distribution process.
- b) The transmission power of all the sensors are same and hence all of them have the same radio range  $r$ .
- c) Single-hop strategy is utilized for communication between two sensors.



- d) For each transmit or receive operation the energy is computed.
- e) CHs directly forwards the data to the base station.
- f) The communication medium is wireless.

### 3.3.3 Energy Consumption Model

We used the energy model for the radio equipment energy dissipation as proposed by Heinzelman *et al.* [18]. The transmitter disperses energy to run the radio equipment and the power amplifier. The receiver also dissipates some energy to run the radio gadgets. Both the free space ( $\epsilon_{fs}$ ) ( $d^\alpha$  power loss) and the multi-path ( $\epsilon_{mp}$ ) fading ( $d^\alpha$  power loss) channel models are utilized, contingent upon the distance between the transmitter and receiver. The threshold  $d_0$  for practical frameworks utilizing low pick up antennas is commonly decided to be one meter in indoor situations and hundred meters in outside situations. The energy spent for transmission of a  $b$ -bit packet over distance  $d$  is shown in Figure 3.1.

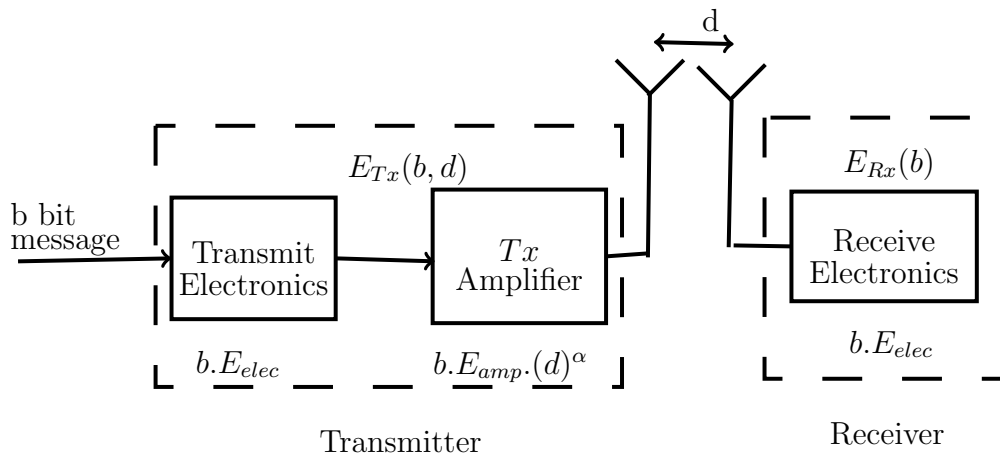

Figure 3.1: Radio Model

The electronics energy,  $E_{elec}$ , is the energy spent per bit to transmit or receive, which depends on factors such as the digital coding and modulation.

The amplifier energy,  $\in_{fs} \times d^\alpha$  or  $\in_{mp} \times d^\alpha$ , depends on the transmission distance and the acceptable bit-error rate. In the radio model of Tx amplifier, we use  $\alpha = 2$  for free space and  $\alpha = 4$  for multipath model.

$$E_{Tx}(b, d) = \begin{cases} b * (E_{elec} + \in_{fs} * d^\alpha), & \text{if } d < d_0, \\ b * (E_{elec} + \in_{mp} * d^\alpha), & \text{if } d \geq d_0 \end{cases} \quad (3.1)$$

To receive this message, the radio expends energy:

$$E_{Rx}(b) = b * E_{elec} \quad (3.2)$$

Cluster head consumes  $E_{DA}(nJ/bit/signal)$  amount of energy for routine data aggregation.

### 3.3.4 Clusterhead Selection Mechanism

In this stage, the algorithm chooses cluster-heads in view of the communication signal quality and the quantity of neighbors. Here, a few provisional cluster-heads are arbitrarily selected to seek final cluster-heads with the same probability. Nodes those fail to be provisional heads continue sleeping until the cluster-head determination stage closes. Every provisional cluster-head  $v_i$  has a transmission range  $T_i$ . The signal strength  $S_i$  can be figured by  $(1 - c) \times T_i$ , where  $c$  is a constant coefficient ( $0 \leq c \leq 1$ ). The quantity of clusters can be determined by figuring a number of neighbors. It can be minimized by calculating the following parameters based on certain assumption like  $n_c$  is the expected number of cluster-heads. From the inequality math relation [67], we can apply a confinement to the required number of clusters ( $R_c$ ) to be made in each round:

$$R_c = \sqrt{\frac{n}{2\pi} \times \frac{M^2}{n_c}} \quad (3.3)$$

Where  $M$  is the maximum distance between the base station and the farthest node present in the network.

In the cluster-head selection process, each provisional cluster-head nodes broadcast HELLO\_MSG by setting transmission radius to  $R_0$ . The HELLO\_MSG contains provisional cluster-head node's present status and the energy information. The present status specifies whether the node was a cluster-head in past rounds or not. After accepting HELLO\_MSG, every provisional cluster-head sensor node develops a set of its adjoining provisional heads. The provisional head sensor node  $v_j$  is an adjacent node of  $v_i$  if  $v_i$  is within  $v_j$ 's transmission range. The provisional cluster-head sensor nodes  $v_i$  or  $v_j$  chooses to turn into a final cluster-head in light of the measure of energy they have left with. The node with the most elevated measure of energy will turn into the final cluster-head. At that point, it broadcasts the FINAL\_MSG to illuminate its neighboring provisional cluster-heads. Provisional cluster-head sensor node  $v_j$  quits the competition promptly in the wake of accepting this FINAL\_MSG, and illuminates all the nodes in its neighbor by broadcasting a QUIT\_MSG.

Every non-cluster-head node picks its closest cluster-head with the highest received signal quality and afterward informs the cluster-head by sending a JOIN\_MSG. Each one cluster-head sets up a TDMA schedule and transmits it to the affiliated member nodes. After the TDMA schedule is known to all nodes in the cluster, the setup phase is completed, and the data transmission begins.

This algorithm produces limited number of clusters, so that the intra-cluster communication can be minimized. It additionally lessens inter-cluster interference in the network. All the nodes in the cluster transmit their data to the cluster-head using the TDMA slot. In this methodology, the distance between each one set of cluster-heads can be ascertained as per the received signal quality. Every sensor node registers the approximate distance to the base station with respect to the received signal quality of a beacon signal broadcasted by the base station amid initial deployment. In the event

that a node's distance to the base station is smaller than a threshold (TD.MAX), it sends its data to the base station directly. Else, it discovers a relay node that can forward its data to the base station. The relay node is picked in light of the energy expense of the relay path.

## 3.4 The Proposed Distributed Dynamic Clustering Protocol (DDCP)

In this section, we discuss the working procedure of the distributed dynamic clustering protocol for wireless sensor networks,

### 3.4.1 Work Flow of the Protocol

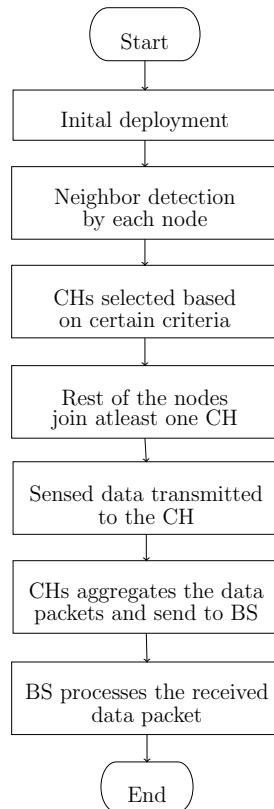

Figure 3.2: Flow chart of the algorithm

Figure 3.2 shows the working procedure of the clustering protocol. Initially the sensors are deployed throughout the sensing field to cover the total area. The neighbor detection is the next process to continue the clustering process. Then, the cluster-heads are selected based on energy information and number of neighbors. After the CH selection, the rest of the nodes join to the cluster-heads. After the clustering job is completed, the data communication from nodes to CHs is started. Finally, the CHs aggregates the data packets and sends to the BS.

### 3.4.2 Description of the Protocol

This section depicts about distributed dynamic clustering protocol (DDCP) which can be applied to a heterogeneous wireless sensor network. The network model is made out of two sorts of nodes deployed randomly in a square area, including normal nodes and advanced nodes. Each advanced node can be chosen as initial cluster-heads in view of the weighted probability of starting energy with respect to that of all the node's average energy in the network. It is assumed that  $n$  normal nodes and  $m$  number of advanced nodes are deployed in an area in random fashion. In this algorithm,  $L$  indicates the lifetime of the network. A percentage of the researchers have considered the lifetime as the time distinction between the beginning time of the network and the time when the first node dies. It is all that much impractical that if one node goes out of energy then the network is dead. Here, we considered the lifetime  $L$  of the network until at least 50 % of the node dies. Sensors in a WSN are susceptible to failures because of restricted battery power. It is considered that,  $E_0$  is the initial energy of each normal node. Let the energy of advanced nodes are furnished with  $\alpha$  times more energy than the normal nodes. So the initial energy of each advanced node is,  $E_0(1 + \alpha)$

So, the total energy of the heterogeneous network can be defined as,

$$E_T = nE_0 + mE_0(1 + \alpha)$$

During reclustering, the data processing and communication must be ceased in the sensor network. The recurrence of re-clustering exceedingly influences lifetime of a sensor network and its energy proficiency. DDCP begins the reclustering process when it gets a signal from the cluster-head that drains almost 50% of its initial energy. This algorithm gives on-demand reclustering instead of the periodical methodology that followed by a large number of customary clustering algorithms.

### 3.4.3 Network Model

The WSN comprises of  $N$  sensor nodes  $v_1, v_2, v_3, \dots, v_n$ . The sensor nodes are arbitrarily deployed in the network that form a random network topology. Sensor nodes are considered as neighboring sensors when they are inside the transmission range ( $R_{Tx}$ ) of one another. Each sensor node  $v_i$  maintains a neighbor table  $S(v_i)$  that stores the set of IDs of the neighbor nodes. All sensor nodes in the WSN are indistinguishable and are organized into non-overlapping clusters. Nodes are composed into one-hop clusters where each member node is mindful of its own cluster-head. The cluster-heads drain their battery power very fast in comparison to the member nodes. This situation demands for reclustering in order to prolong the lifetime of the network.

Every node in the sensor network can be a CH, in view of the weighted probability function of spatial density and energy of the node. The correspondence between the CHs with the BS is minimized by utilizing data aggregation methods. The member nodes must be at a distance of one-hop from the cluster-head. The neighbor detection is the initial phase of this clustering algorithm, which helps in measuring the distance amongst nodes. The CHs are chosen in light of the geographic range and the remaining energy of the nodes in each round. There are some suppositions taken for

building the network, which are as per the following,

- a) All the sensor nodes must be randomly deployed inside the landscape.
- b) The BS is fixed, and the sensor nodes are stationary after the deployment.
- c) This network comprises of heterogeneous nodes i.e. the nodes having the distinctive measure of energy.
- d) Continuously the data aggregation is performed only at the cluster-head.
- e) The BS doesn't have any energy constraint or computation limitation.

In the clustering phase, the protocol builds a cluster-head backbone rooted at the base station. In this methodology, the distance between each one set of cluster-heads can be ascertained amid the neighbor revelation process. Every sensor node processes the approximate distance to the base station in light of the received signal strength of a beacon signal broadcasted by the base station amid introductory deployment. On the off chance that a CH's distance to the base station is smaller than a threshold (TD\_MAX), it transmits its data to the base station directly. Else, it discovers a relay node that can forward its data to the base station. The relay node is picked taking into account the energy expense of the relay path. The CHs save their residual energy in their memory toward the end of every setup phase. At whatever point a CH observes that its  $E_{residual}$  gets to be less than  $\alpha E_{CH}$ , it sends a synchronization bit in the data packet to the base station. Next, the base station informs to all the nodes that re-clustering will be performed in the following round.

### 3.4.4 Analysis of the Algorithm

In situations where the node density in the area is not equal, we have to be cautious at the time of selecting the cluster-heads. Because the cluster-heads with weak neighbor density live for more time as compared to the

---

**Algorithm 1** DDCP Algorithm

---

- 1: The threshold =  $d_0 = \sqrt{\epsilon_{fs} / \epsilon_{mp}}$
  - 2: Random distribution of  $n$  sensor nodes.
  - 3: **for**  $i \leftarrow 1$  to  $n$  **do**
  - 4:   **for**  $j \leftarrow 1$  to  $n$  **do**
  - 5:      $d(i,j) = \sqrt{(node_i.x - node_j.x)^2 + (node_i.y - node_j.y)^2}$
  - 6:     **if** ( $d(i,j) \leq T_{Rx}$  &&  $j \neq i$ ) **then**
  - 7:        $node_i.nbr = node_j$
  - 8:     **end if**
  - 9:   **end for**
  - 10: **end for**
  - 11: some advanced nodes declares themselves as provisional cluster-heads.
  - 12: Each provisional CH sends a HELLO\_MSG
  - 13: After receiving all the HELLO\_MSG the provisional CHs maintains a neighbor list.
  - 14: Randomly any one from the neighbor declares itself as CH and other one give up the competition.
  - 15: Then the final list of CHs came into picture
  - 16: Now other member nodes joins the corresponding CHs.
  - 17: Let  $E_{CH}$  be the residual energy of CH.
  - 18:  $\alpha$ , is a random number between 0 to 1.
  - 19:  $\forall v_i \in n$ , and  $E_{residual}(v_i) > 0$ ,
  - 20: **if** ( $E_{residual}(v_i) < \alpha E_{CH}$ ) **then**
  - 21:   node  $v_i$  gives a synchronization pulse to the BS
  - 22: **end if**
  - 23: **if** synchronization pulse received by the BS **then**
  - 24:   BS informs to  $\forall v_i$  that Clustering will be performed in the upcoming round
  - 25: **end if**
-



cluster-heads from high density area. Amid data transmission, when a node chooses to transmit a packet, it is scheduled for an assignment in a sensor node. The aggregate time spent in developing the packet at the application layer and after that sending to MAC layer is the propagation time. The deferral in transmitting a packet at the physical layer over the wireless link is fundamentally deterministic in nature and can be evaluated utilizing the packet size and the radio speed. The propagation delay is the genuine time taken by the packet to navigate the wireless connection from the sender node to the receiver node. It is irrelevant when contrasted with different sources of delay. The reception delay alludes to the time taken in accepting the bits and passing them to the MAC layer.

## 3.5 Simulation Results and Discussions

We have simulated a wireless sensor network of 500 nodes deployed randomly over a square area of  $500 \times 500 m^2$ . The sink node placed in the middle of the terrain. The simulation parameters are demonstrated in Table 3.2. We expect that  $m$  is the percentage of the nodes that are outfitted with  $\alpha$  times more energy than the normal nodes. The initial energy of normal node is  $2J$ , so the initial energy of advance node is  $2(\alpha + 1)J$ .

### 3.5.1 Performance metrics

**Network lifetime:** The lifetime of the network emphatically relies on upon the individual life span of each single node that constitutes the WSN. It is fundamentally reliant upon two main considerations: firstly, the measure of the energy it spent over rounds and also, the measure of energy needed for data aggregation and data sending. The lifetime is individually corresponding to the measure of data received from the network. Thus, the amount of time the sensor nodes will stay alive that gives a more noteworthy as a result of the

Table 3.2: Simulation parameters

Parameter	Value
Area	$500 \times 500$
Nodes	500
Base Station	(250,250)
Initial Energy (normal node)	2J
$E_{elec}$	50nJ/bit
$\epsilon_{fs}$	10pJ/bit/ $m^2$
$\epsilon_{mp}$	0.0013pJ/bit/ $m^4$
$E_{DA}$	5nJ/bit/message
Packet Size	2000 bits
Frames/round	30

lifetime of the sensor network.

**Number of clusters:** The lifetime of the network is affected based on the number of clusters created in each round. The clusters are created depending on the number of CHs selected by the algorithm. The selected cluster-head nodes will exhaust energy rapidly, because they handle data aggregation and data forwarding. It is well observed that, after a certain number of clusters, clustering reduces the lifetime rather than increasing it. So it is necessary to minimize the number of cluster-heads to extend the lifetime of the network.

### 3.5.2 Study 1: Efficiency with regard to percentage of advanced nodes ( $m$ )

The performance of DDCP protocol is compared with LEACH, DEEC and EECS in the same heterogeneous setting, where  $m = 0.5$  (percentage of advanced nodes),  $\alpha = 0.8$  (energy difference between normal and advanced nodes),  $b = 2$  (heterogeneity level),  $l=4000$  (message size) and  $tr$  is the

transmission range. The notation  $E_{elec}$  specifies the energy dissipated to run the electronics circuits.  $\epsilon_{fs}$  and  $\epsilon_{mp}$  are the energy parameters. But the  $E_{DA}$  specifies the amount of energy for data aggregation. The CH can often aggregate the data into a single packet that are received from the member nodes. Thus, the sensed information is considered as highly co-related. We employ the *number of rounds* as a metric to quantify the time required to build the network.

In this simulation the duration of each *round* is taken as 500 milliseconds. Figure 3.3 shows the wireless sensor network consisting of 500 nodes deployed in a square area with a random distribution. We denote a normal node with “o”, an advanced node with “+”, the dead nodes with red “.” and the BS with “×”. Here the number of advanced nodes are 0.2 times than the normal nodes present in the network. It also shows the number of dead nodes after 500 rounds from the beginning of the algorithm.

Whereas, Figure 3.4 shows the network with 0.5 times advance nodes than the normal nodes. The advanced nodes are having more energy than the normal nodes, so it lives a longer time than the normal nodes. It can be observed that this network is more robust than the network having 0.2 times of advanced nodes. From the above two figures it can be analyzed that the number of dead nodes present in Figure 3.3 is much higher than the dead nodes present in Figure 3.4. So it draws this conclusion that, if we put more number of high energy nodes then the lifetime will be increased accordingly.

Figure 3.5 shows the time when the first node dies in the network according to the different heterogeneity parameter  $m$ . Here it can be observed that, as the heterogeneity level increases the lifetime of the network also increases, so they are directly proportional to each other. But after a certain level the lifetime becomes constant.

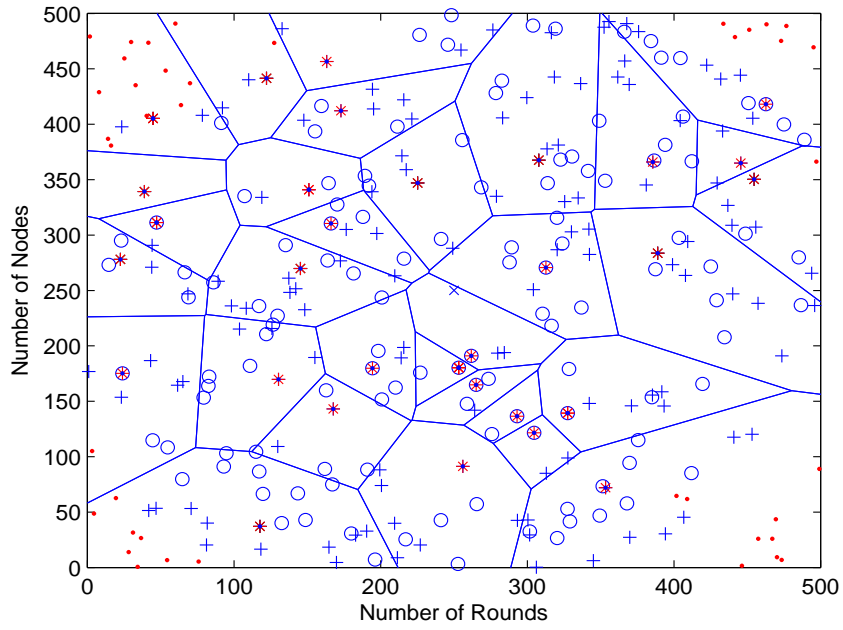

Figure 3.3: Wireless Sensor Network with 0.2 times advanced nodes

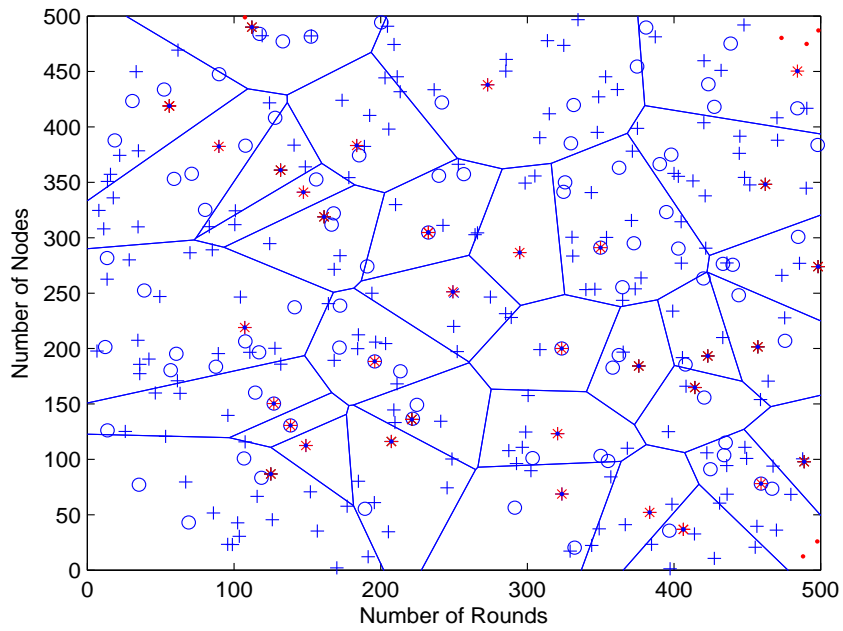

Figure 3.4: Wireless Sensor Network with 0.5 times advanced nodes

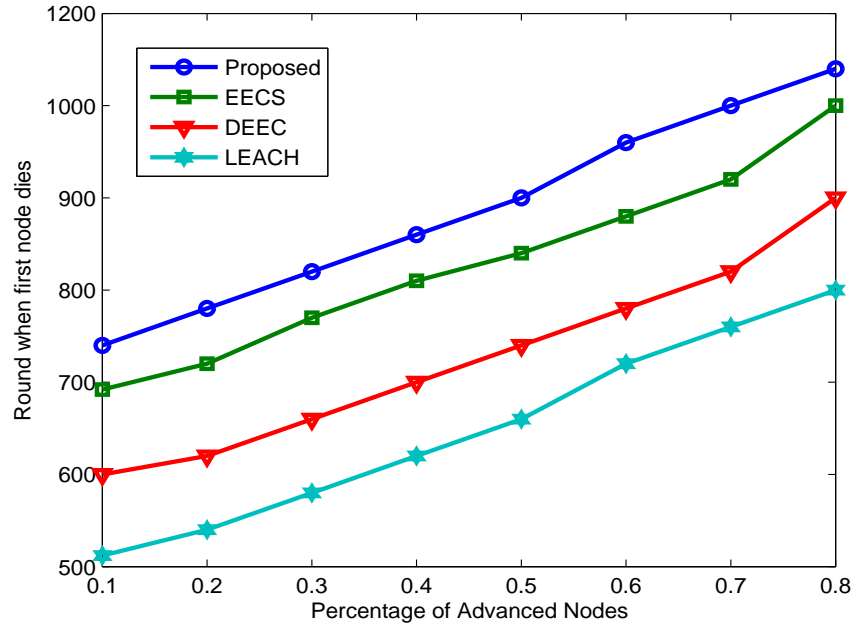

Figure 3.5: Efficiency based on percentage of advanced nodes

### 3.5.3 Study 2: Robustness with regard to number of cluster-heads

Figure 3.6 shows the number of cluster-heads created in each round. The number of CHs established in each round are different. According to the transmission range of each sensor, the clusters are created. If any of the nodes found in the network, who doesn't come in the range of any of the CH then that node becomes a CH. So it is crucial to minimize the number of cluster-heads so that higher lifetime can be achieved for the network. If a larger number of nodes will be appointed as CHs then the energy level of all the CHs decreases, so that the lifetime of the network decreases. Figure 3.6(a) shows the number of cluster-heads created in a different round of LEACH algorithm. Whereas, Figure 3.6(b) shows the number of CHs created in a different round of EECS algorithm. But the number of cluster-heads created in a different round of DEEC algorithm are shown in Figure 3.6(c). And Figure 3.6(d) shows

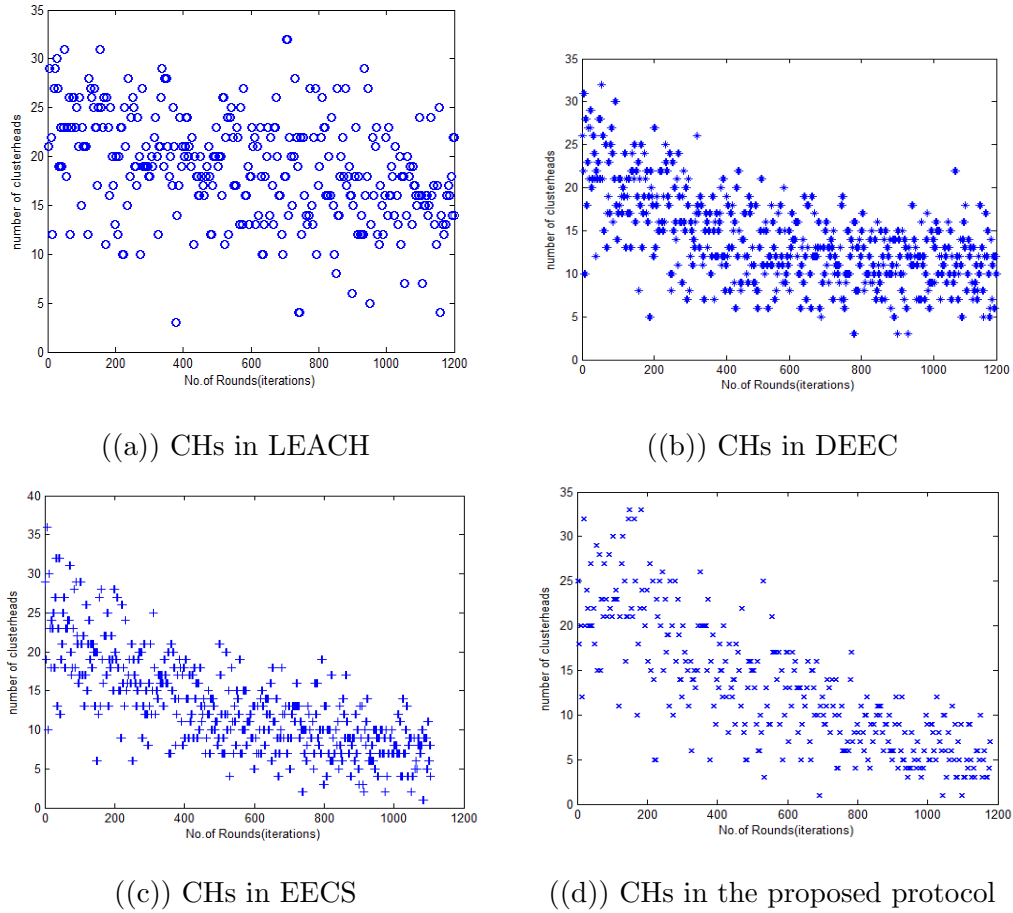

Figure 3.6: Number of cluster-heads created for different protocols

the number of CHs created in a different round of the proposed algorithm. The Figure 3.6 clearly describes the density of the CHs created for different protocols. The number of CHs created by the proposed protocol is 7 %,5 % and 11 % lesser than LEACH, EECS and DEEC respectively. At the beginning of the rounds, the number of CHs is much higher than in the end because all the sensor nodes have higher power level at the start of the clustering process.

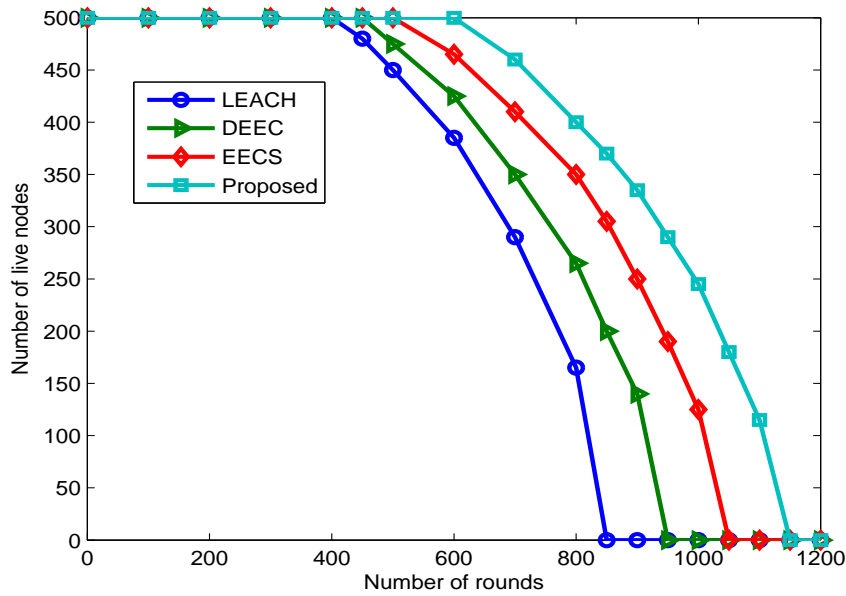

Figure 3.7: Lifetime comparison between different algorithms

### 3.5.4 Study 3: Efficiency with respect to Network lifetime

Figure 3.7 shows that DDCP remarkably extends the stable region compared to existing algorithms. On the other hand, DDCP attains higher lifetime than the algorithms like LEACH, DEEC and EECS. The algorithm selects the nodes as cluster-head, which is left with a large amount of residual energy, and the low energy nodes join the CHs as member nodes. The number of alive nodes compared to different protocols at different time intervals known as *rounds* measured in milliseconds. The starting time of demolition of the first node of DDCP is much higher than the compared protocols, so it performs better utilization of the network with all the alive nodes.

### 3.5.5 Study 4: Case study for the use of clustering in wireless Brain Computer Interface

One of the prominent application of WSN is sensing the human parameters and map them with the computer/machine to realize the brain signals. In case of brain computer interface, a wearable braincap can be used for the deployment of the sensor nodes. Due to the small application area the number of sensor nodes may be reduced significantly. The sensor nodes present on the braincap are required to transmit the brain signal to the base station. The base station could be available at a small distance from the braincap. In case of direct communication each sensor node spends equal amount of energy for data transmission. But after the use of clustering for the sensor network the energy consumption is minimized. All the member nodes send data to the respective cluster-heads which requires very less amount of energy as compared to the direct communication methodology. The cluster-heads only required more energy to transmit data to the base station. In this way, the lifetime and efficiency of the network is increased by using a constant amount of energy source.

The lifetime of the proposed protocol can be tested on a different simulation setting, where area of the network is  $5 \times 5 \times 5 \text{ cm}^3$  and number of nodes are hundred with a structural deployment. Figure 3.8 shows the lifetime comparison of different protocols in the same simulation settings.

## 3.6 Summary

In this chapter, a distributed dynamic clustering protocol (DDCP) for heterogeneous wireless sensor networks has been proposed. The suggested protocol minimizes the cost of communication energy to enhance the lifetime of the network. The protocol takes the decision of re-clustering based on the



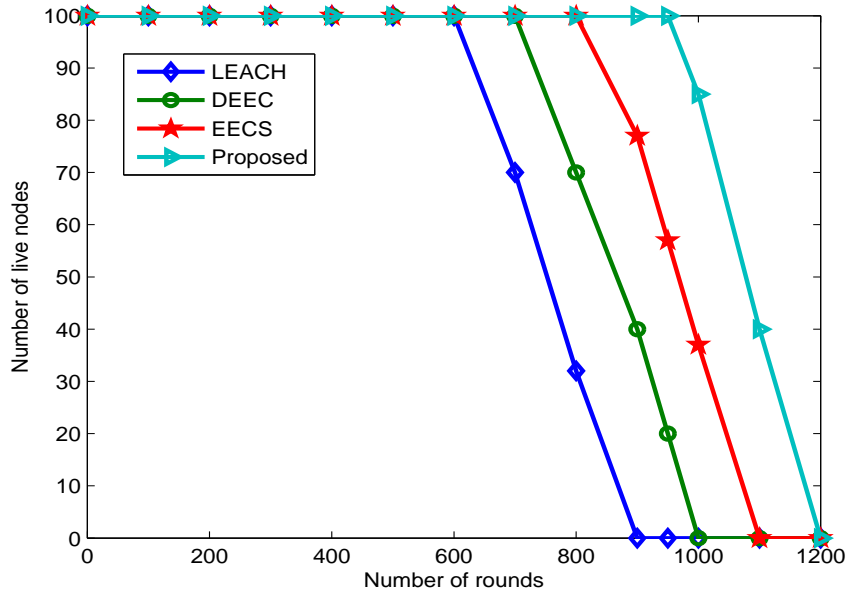

Figure 3.8: Lifetime of the algorithms on different simulation settings

information received from the cluster-heads. A sensor node is selected as a cluster-head that is based on the residual energy and the number of neighboring nodes. The proposed DDCP is not dependent on the geographic information. Hence, it is scalable to a large number of nodes. This protocol mainly depends on local information like energy information and communication cost for the clustering purpose. Simulation results have been discussed to describe the CH selection procedure, the effect of heterogeneity and the lifetime of the network. The DDCP achieves the advantage of on-demand re-clustering approach. From further investigation, it has been observed that the energy efficiency is a viable factor besides the enhanced lifespan of the entire network. This factor leads to improve the efficacy of the designed network. Thus, the observed requirement can be incorporated in the further contribution.

## Chapter 4

# Staggered Clustering Protocol for WSN

---

(Effectiveness of energy efficient clustering protocol is showcased)

## 4.1 Introduction

Wireless sensor networks contain a considerable amount of low-power sensor nodes to construct the network. Substantially it can be utilized in an extensive variety of uses, for example, in the military applications, ecological sensing and environment observing [85]. WSN alludes to a gathering of spatially scattered and devoted sensors for checking and recording the physical data. Thus, it is vital to outline clustering protocols, which can expand network lifetime, throughput of the network and reduce the energy consumption by the nodes at the same time [39]. The sensor nodes are irreplaceable, so it requires more consideration towards energy efficient protocols. Essentially, clustering is the methodology of grouping the sensor nodes shrewdly, which will bring about noteworthy enhancements in wireless sensor networks [46]. WSNs are networks of dispersed autonomous gadgets that can sense the ecological conditions agreeably. It confronts numerous difficulties mainly brought on by communication failures, low memory space and computational imperatives. The constrained power supply plays a vital role where battery substitution or recharge is troublesome or even difficult to be performed. These networks are fundamentally information gathering networks where information are profoundly associated [92]. A robust clustering algorithm should attempt to generate clusters with well-positioned cluster-heads and minimize the communication cost among the sensor nodes.

The available energy of a node is restricted due to its miniaturized size. In the situations where the sensor nodes work in remote or inaccessible areas, it might be difficult to recover the nodes keeping in mind that recharging the battery is impossible. In this manner, the network is relied upon to get higher lifetime when the nodes have sufficient energy to assemble, process, and transmit information. This implies that the designing of new clustering protocols must be intended to be energy efficient. In spite of decreasing

energy scattering, protocols ought to have the capacity to adjust the energy dissemination of nodes so that the lifetime of the network is augmented.

The rest of the chapter is composed as follows. Section 4.2 determines the genuine issue to be comprehended in this chapter. Where as Section 4.3 gives the solution to the problem referred in the previous section. The system model that comprises of network model and energy model is portrayed in Section 4.4. The clustering parameters are delineated in Section 4.5. In Section 4.6, the proposed energy efficient clustering algorithm is clearly described elaborately. The operation of the proposed algorithm is demonstrated in Section ???. Followed by the analysis of the algorithm in Section 4.7. Section 4.8 presents the simulation results and discussion of the algorithm. Finally, Section 4.9 summarizes the chapter.

## **4.2 Problem Statement**

The number of nodes deployed in the wireless sensor network are large. Accordingly, the general data packets in the network are considerable but large data packet will bring about critical energy dissemination for nodes. Since the nodes are energy compelled, the clustering protocol is obliged to be energy proficient. The energy utilization by the nodes in the network differs by position, so the protocol ought to have the capacity to adjust the energy scattering of nodes. The sensor nodes in a wireless sensor network may be far away from the base station. Long distant data transmission will bring about impressive energy dispersal. Along these lines, the clustering protocol ought to have the capacity to minimize the energy utilization of data transmission from nodes to the base station. Therefore, the issues that need to be carried out in the configuration of clustering protocol can be described as:

- Effectively deploy the nodes by certain distribution process.

- Utilize efficient method to adjust the energy utilization of nodes.
- Instructions to minimize the energy dissemination of data transmission from sensor nodes to the base station.

### 4.3 Proposed Solution to the Problem

The problem of energy-efficiency in a wireless sensor network is a major parameter in case of designing the network. The clustering methodology is a sensible answer for such a network scenario. It can productively compose various nodes, aggregate data, and diminish energy scattering of nodes [96]. The CHs send accumulated information to the BS, that is situated far from network area. Utilizing a proficient multi-hop clustering can minimize the energy dispersal of data transmission from CHs to the BS [97].

These effective strategies lead us to develop an energy efficient clustering protocol for WSN. The clustering protocol comprises of the following steps:

- Initially, the cluster-heads (CHs) are selected.
- Then, the member nodes join the CHs to form the clusters.
- After clustering, the data transmission starts with sensor nodes and the base station via corresponding cluster-heads.

### 4.4 System Model

We portray the system model, consisting of the network model and the energy model in this section.

#### 4.4.1 Network Model

The network model provides the working environment that comprises of  $N$  number of nodes with one base station. All the nodes are arbitrarily deployed

in a  $L \times L$  region with the base station found outside or inside the node zone. The members of the sensor network periodically gather the required data and forwards to the BS. While the base station is in-charge of accepting data from nodes and presenting the end-client a portrayal of the sensed environment. The network model has the following properties:

- Every node has comparable abilities of sensing, processing power, and communication;
- Each of the node is energy compelled;
- The beginning energy of the nodes can be distinctive;
- Each node has the capacity to fluctuate its transmission power. This implies nodes can change their transmitting reach in light of the prerequisite;
- All nodes are fixed;
- The base station is settled and has no energy constraint.

Moreover, in spite of the energy oblige, every node has sufficient energy to correspond straightforwardly with the others including the BS. Likewise, each node has a little bit of processing power to pre-process the data before it is sent to the cluster-head. Also, the nodes have low amount of memory to store small information packets.

#### 4.4.2 Energy Model

In this protocol, we utilized the energy model used in [39] to gauge the energy dissemination for our network. The energy model comprises of a transmitter, power amplifier, and receiver. The energy model has two propagation models: 1) free space model and 2) multi-path fading model. In case of free space propagation model there is immediate, observable pathway

between the transmitter and the receiver. But, the engendering between the transmitter and the receiver is not immediate in case of multi-path fading model. In this model, the electromagnetic wave will bounce off the ground and land at the receiver from diverse ways at distinctive times. The propagation loss for transmitting power in free space model is considered as  $d^2$ , where  $d$  is represented as the distance from the transmitting node and the receiving node. Whereas, the propagation loss for transmitting power is considered as  $d^4$  in case of multi-path fading model.

The transmitting power can be enhanced amid the transmission by the power amplifier to repay the propagation loss. Accordingly, the amount of energy required to transmit a  $b$  bit message from the source to destination at a distance  $d$  is characterized as:

$$E_{Tx}(b, d) = \begin{cases} b * (E_{elec} + \epsilon_{fs} \cdot d^\alpha), & \text{if } d < d_0, \\ b * (E_{elec} + \epsilon_{mp} \cdot d^\alpha), & \text{if } d \geq d_0 \end{cases} \quad (4.1)$$

Where  $E_{Tx}$  specifies the amount of energy disseminated for transmitting a data packet, but  $E_{elec}$  defines the energy dissipation per bit in transceiver hardware. The power amplifier parameter used for the free space propagation model is  $\epsilon_{fs}$ . Whereas, for the multi-path propagation model the energy amplifier parameter  $\epsilon_{mp}$  is used. The traverse distance,  $d_0$ , can be obtained from:

$$d_0 = \sqrt{\frac{\epsilon_{fs}}{\epsilon_{mp}}} \quad (4.2)$$

If the distance  $d$  between the source and the destination is bigger than the traverse distance  $d_0$ , the multi-path propagation model is utilized. Else, the free space model is employed to quantify the energy dissolution. The amount of energy needed for accepting an  $b$  bit message is:

$$E_{Rx}(b) = b * E_{elec} \quad (4.3)$$

## 4.5 Clustering Parameters

In clustering, the sensor nodes in a WSN are isolated into distinctive virtual groups, and they are apportioned topographically adjacent into the same group as indicated by some set of heuristics. In a linked cluster architecture, sensor nodes may be appointed as an alternate status or capacity, for example, CH or member node. The cluster-head performs as a coordinator between the member nodes with the base station. The responsibility of the CHs is to aggregate all the data packets received from the member nodes and forward to the base station as a solitary packet. Clustering has the following advantages:

- Reduces energy utilization by node and enhances bandwidth utilization.
- Reduces overhead by changing the CHs from time to time.

The vast majority of the algorithms expect to develop the network lifetime by adjusting energy utilization among nodes and by circulating the load among distinctive nodes now and again. Amid the renewal of clusters, the cluster-head is changed alongside the individuals partnered to it. In WSN, the essential concern is the energy effectiveness with a particular end goal to expand the utility of the network.

## 4.6 Proposed Staggered Clustering Protocol

In this section, a staggered clustering protocol for WSNs is proposed. The proposed protocol minimizes the energy consumption of the network as compared to other existing clustering protocols.

### 4.6.1 Description of the Protocol

In case of designing clustering protocol, the first step towards the development is to select the cluster-heads. The CHs are selected based on



combined weighted value of energy and transmission cost. The selected cluster-heads serve as the public face for the respective clusters. They are responsible for doing numerous energy devouring assignments, for example, data receiving, data aggregating, and data forwarding. Accordingly, the energy consumed by a CH can be calculated based on the quantity of neighboring nodes served by it and transmission distance between itself and the BS. Also, the advanced nodes having more energy are picked as CHs ahead of the normal nodes. In this algorithm, the selected cluster-heads take necessary measures for achieving the intra-cluster and inter-cluster communication to be energy efficient.

At the time, when it is found that the energy level of any of the cluster-head becomes less than a predefined value, the respective cluster-heads inform to the base station to perform the clustering algorithm again. So that new CHs can be appointed before the death of the previous cluster-head. Thus, the network will give continuous performance without any break. The best selection of cluster-heads enrich the algorithm to provide better performance. There is a chance that the cluster-heads will get redundant data from the member nodes, which needs to be taken care of at the time of data aggregation.

### 4.6.2 Cluster Head Selection Mechanism

In clustering protocol, the nodes are organized into small groups called as clusters. The clusters are composed of a CH and some member nodes. The sensed data of the member nodes must be transmitted to the respective cluster-heads. The CH performs data aggregation and sends to the remote BS [98]. The cluster-head determination procedure used in this protocol is described below,

We characterize the sensor nodes of the network as  $N = n_1, n_2, \dots, n_m$ , where  $m$  is the number of nodes in the network. The residual energy of every node  $n$ , is termed as  $E_n$ .

**Step 1:** Calculate the set of neighbors for every node  $n$ :

$$S(n) = \sum_{n' \in N} \{distance(n, n') \leq I_c\} \quad (4.4)$$

Where  $S(n)$  is the set of neighbors of node  $n$ ,  $distance(n, n')$  gives the transmission distance in between node  $n$  and node  $n'$ , where as  $I_c$  shows the transmission range.

**Step 2:** Figure out the aggregate of square distance in between node  $n$  and its neighbors as,

$$d_n = \frac{1}{|S(n)|} \sum_{n' \in S(n)} distance(n, n')^2 \quad (4.5)$$

**Step 3:** Calculate the distance  $D_n$  for every node  $n$

$$D_n = Dist(n, BS) \quad (4.6)$$

where  $Dist(n, BS)$  is the transmitting distance between the node  $n$  and the base station ( $BS$ ).

**Step 4:** Ascertain the joined weight for every node  $n$  as:

$$W_n = (|S(n)| + d_n + D_n) \frac{E_0}{E_n} \quad (4.7)$$

Where  $E_0$  = the initial energy of the node  $n$  in joule.

$E_n$  = the current energy of the node  $n$  in joule.

**Step 5:** The node having smallest  $W_n$  is selected as the CH. Once a cluster-head is determined its neighbors are considered as member nodes.

**Step 6:** The steps from 2 to 6 will be repeated for the remaining nodes to complete the clustering algorithm.

### 4.6.3 Analysis of Cluster Head Selection Mechanism

The central point of this algorithm is to be more energy efficient when contrasted with other existing ones. Hence it utilizes two fundamental

parameters, for example, average energy and the transmission cost in between nodes. The average energy of all the nodes can be calculated as follows,

$$AE_n = \frac{\sum_{n' \in S(n)} E_{n'}^{current} + E_n^{current}}{|S(n)|} \quad (4.8)$$

In this equation,  $E_{n'}^{current}$  shows the present energy estimation of all the neighbors of node  $n$ , and  $E_n^{current}$  is the current energy estimation of node  $n$ . Whereas,  $AE_n$  reflects the average energy of all the nodes present in the network. On the off chance that the residual energy of any node  $n$  gets to be not exactly the  $AE_n$  then the node is considered as a low energy node. The low energy nodes are disregarded at the time of cluster-head selection process. So the nodes having more residual energy when contrasted with  $AE_n$  are considered to turn into a cluster-head in the resulting rounds.

In the cluster-head selection process, both the average power refinement and communication cost are given equivalent significance. The communication cost for each node is computed as,

$$C_{cost} = E_n^{current} \cdot \frac{\sum_{n' \in S(n)} distance(n, n')}{|S(n)|} \quad (4.9)$$

Where  $distance(n, n')$  is the transmitting distance between the node  $n$  and node  $n'$ , which is calculated with respect to the received signal strength indicator (RSSI). After the estimation of  $C_{cost}$  for each node, it is supplied to the base station. At that point, in view of energy information and the communication cost the best suitable nodes are chosen as cluster-heads for each round.

#### 4.6.4 Clustering Algorithm

The operation of the protocol is separated into rounds. Figure 4.1 shows that, a set-up phase is followed after the initial deployment is done.

Furthermore, when the clusters are created, the next step to complete the process is transmission phase.

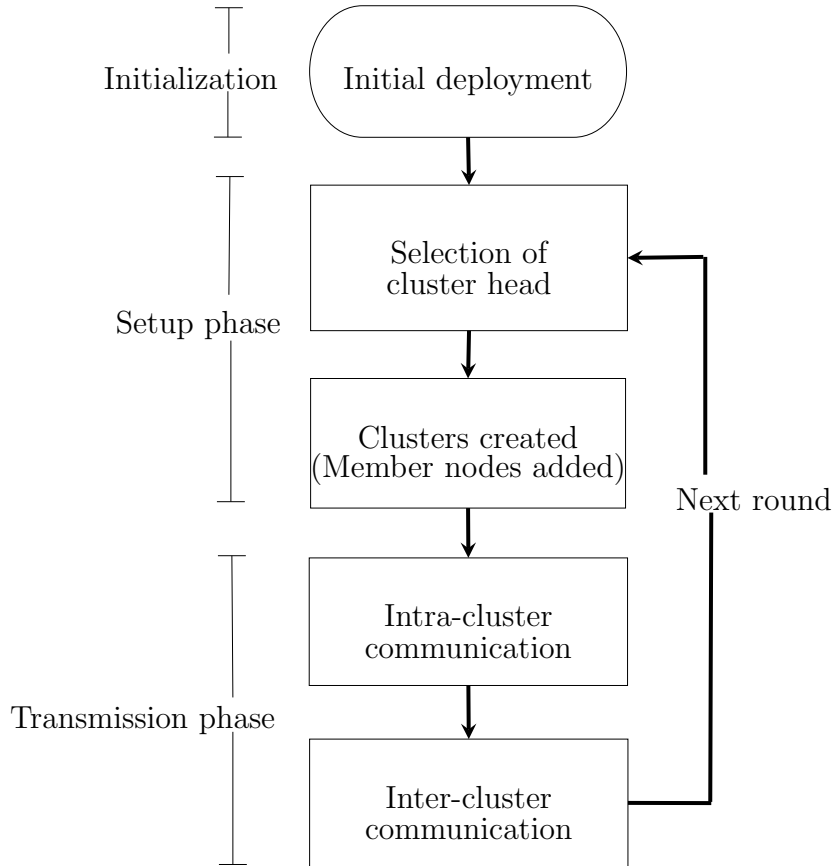

Figure 4.1: Network operation of the protocol

The clustering starts with selecting cluster-heads based on the geographical information of the nodes when they are dispersed throughout the terrain. At the point when the node gets all the data about the neighbors, it computes  $C_{cost}$  and broadcasts to its neighbors. As indicated by  $C_{cost}$ , every node analyzes their candidature for becoming cluster-head. On the off chance that the node ends up suitable for the position then it sends  $elect_{msg}$  to different nodes. The nodes which get the highest  $elect_{msg}$  from neighbors, declares itself as the cluster-head for the current round. All the non-cluster-head nodes then join the closest cluster-head to fabricate the cluster. The node  $n$  who is working as a cluster-head is indicated by  $CH_n$ .

---

**Algorithm 2** SCP Algorithm

---

```

1:  $d_0 = \sqrt{\epsilon_{fs}/\epsilon_{mp}}$ 
2: for  $i \leftarrow 1$  to  $n$  do
3:   for  $j \leftarrow 1$  to  $n$  do
4:      $d(i,j) = \text{sqrt}(((node_n.x - node'_n.x)^2) + (node_n.y - node'_n.y)^2)$ 
5:     if  $d(i,j) \leq tr$  &&  $j \neq i$  then
6:        $node_n.nbr = node'_n$ 
7:     end if
8:   end for
9: end for
10: for  $r \leftarrow 1$  to  $rmax$  do
11:   for  $i \leftarrow 1$  to  $n$  do
12:     Calculate  $AE$ ,  $Ccost$  and  $node_n.broadcast(AE, Ccost)$ 
13:     if  $node_n.E \leq 0$  then
14:        $dead = dead + 1$ 
15:     end if
16:      $node_n.send(elect\_msg)$  to all neighbours
17:     if  $node_n.receive(elect\_msg)$  from  $node_n.nbr$  then
18:        $node_n.ticket = node_n.ticket + 1$ 
19:     end if
20:     if  $Node_n.ticket = Max$  then
21:        $CH \leftarrow node_i$ 
22:     else
23:        $Node_n$  is not CH, associates with nearest CH
24:     end if
25:   end for
26: end for

```

---

## 4.7 Analysis of the Algorithm

Let there are  $N$  number of sensor nodes consistently appropriated in a  $L \times L$  area in this protocol. In the event that we have  $n_c$  number of clusters, then  $\frac{N}{n_c}$  amount of nodes are associated with each cluster. Every cluster comprises of one cluster-head and  $\frac{N}{n_c} - 1$  member nodes. Every CH node scatters energy by getting data from member nodes, performing data aggregation and forwarding the aggregated data to the BS. Subsequently, the energy scattering of the cluster-head  $E_{CH}$  is:

$$E_{CH} = l \times E_{elec} \left( \frac{N}{n_c} - 1 \right) + l \times E_{DA} \frac{N}{n_c} + E_{inter} \quad (4.10)$$

Where  $l$  showcases the amount of bits present in every data packet,  $E_{elec}$  is the parameter characterized in the energy model, and  $E_{DA}$  is the required energy for data aggregation. The amount of energy spent for data transmission from the cluster-head to the base station is denoted as  $E_{inter}$ .

The member nodes in clusters usually send the sensed data to the cluster-head. Apparently the transmitting distances between CHs and the member nodes in the same cluster are not exactly the cross-over distance. So the energy dispersal takes after the free space model. Therefore, the energy devoured by one member node is  $E_{member}$ ,

$$E_{member} = l E_{elec} + l \epsilon_{fs} d_{toCH}^2 \quad (4.11)$$

where  $E_{elec}$  and  $\epsilon_{fs}$  are the parameters characterized in energy model, and  $d_{toCH}$  is the distance from the member node to the cluster-head.

Now the normal energy dispersed in a cluster is:

$$E_{cluster} = E_{CH} + \left( \frac{N}{n_c} - 1 \right) E_{member} \quad (4.12)$$

Total energy is:

$$E_{total} = n_c E_{cluster} \quad (4.13)$$

## 4.8 Simulation and Result Discussion

We simulate a wireless sensor network of 500 nodes in a  $500 \times 500 m^2$  area, and the base station is placed in the middle of the zone. The simulation parameters are indicated in Table 4.1. It is assumed that there are  $p$  percentage of advanced nodes outfitted with  $\alpha$  times more energy as compared with normal nodes are present in the network. The starting energy of each of the normal nodes are present in the network. The starting energy of each of the normal node is 2J, but in case of advance nodes it is 5J. LEACH is considered as the basic clustering algorithm that gave another course to the field of clustering in WSN, whereas DEEC and EECS utilize the two level heterogeneity to improve lifetime over the LEACH.

Table 4.1: Simulation parameters

<i>Parameter</i>	<i>Value</i>
Area	$500 \times 500$
Nodes	500
Base Station	(250,250)
Initial Energy (normal node)	2J
$E_{elec}$	50nJ/bit
$\epsilon_{fs}$	10pJ/bit/ $m^2$
$\epsilon_{mp}$	0.0013pJ/bit/ $m^4$
$E_{DA}$	5nJ/bit/message
Packet Size	2000 bits
Frames/round	30

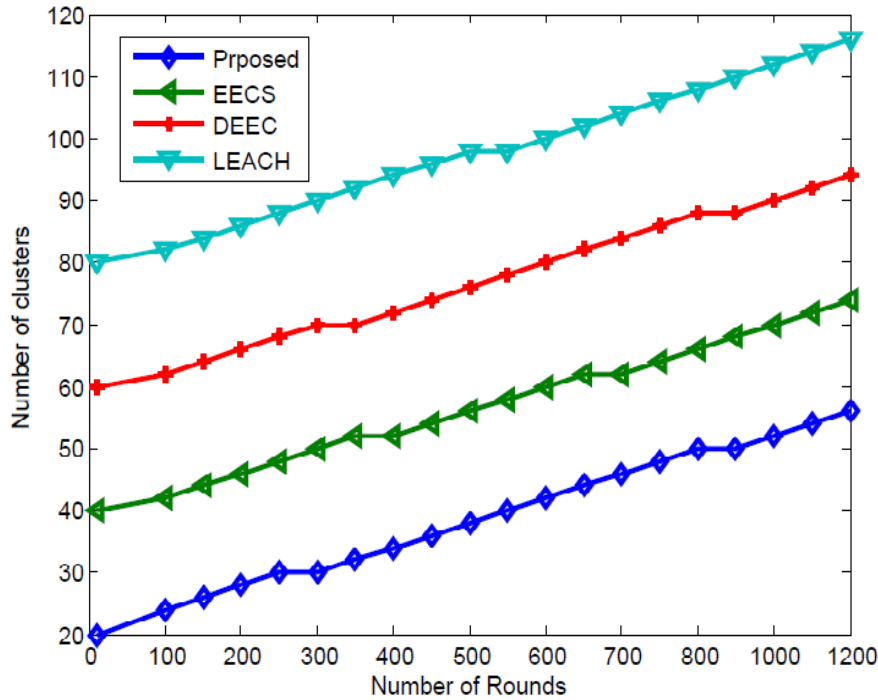

Figure 4.2: Number of Cluster heads per round

#### 4.8.1 Study 1: Robustness with regard to numbers of clusters

Figure 4.2 exhibits the amount of cluster-heads made in each round. The number of CHs selected in each round is not same, in light of the way that the amount of clusters is not settled. According to the transmission range and the nature of energy data received, the clusters are created. Furthermore, the lifetime of the network is very much subject to the number of cluster-heads appointed. The lifetime of the network is directly affected based on the number of clusters created by the clustering algorithm.



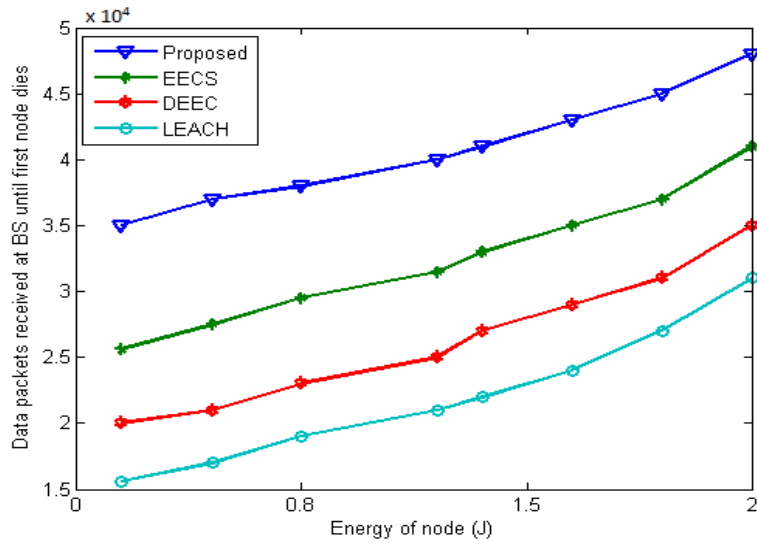

Figure 4.3: Amount of data packets received at the base station until the first node dies versus initial energy

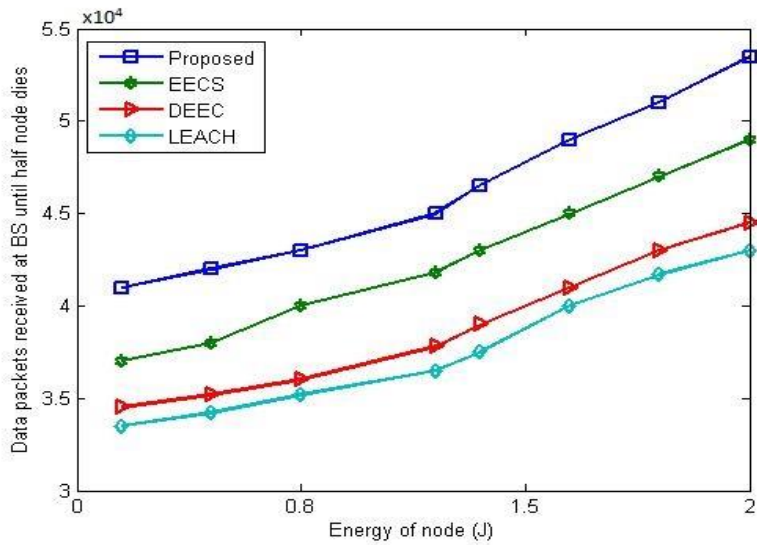

Figure 4.4: Amount of data packets received at the base station until half the nodes die versus initial energy

### **4.8.2 Study 2: With respect to the number of data packets transmitted**

The wireless sensor network is data-oriented network, whose priority is to get the real data. The data are transferred to the base station through the cluster-heads by the manifestation of data packets. In this way, the estimation of data packets transmitted in a network is given most extreme significance. The number of data packets transmitted in the network until the first node of the network dies is shown in Figure 4.3. Whereas, the quantity of data packets received at the base station until half of the node die is explained in Figure 4.4.

### **4.8.3 Study 3: With respect to energy consumption**

Figure 4.5 demonstrates that the proposed protocol is more energy efficient than LEACH, DEEC and EECS. Residual energy is the amount of energy left with the node. The node that is having more residual energy will have more opportunities to turn into a CH. In heterogeneous networks, the advance nodes have more opportunity to be the cluster-head so that the lifetime of the network will be expanded. This protocol gives better performance when contrasted with other existing ones due to the energy efficiency parameters used for data transmission. Determination of high energy node with low communication cost remain the key parameter for achieving energy efficiency in the protocol.

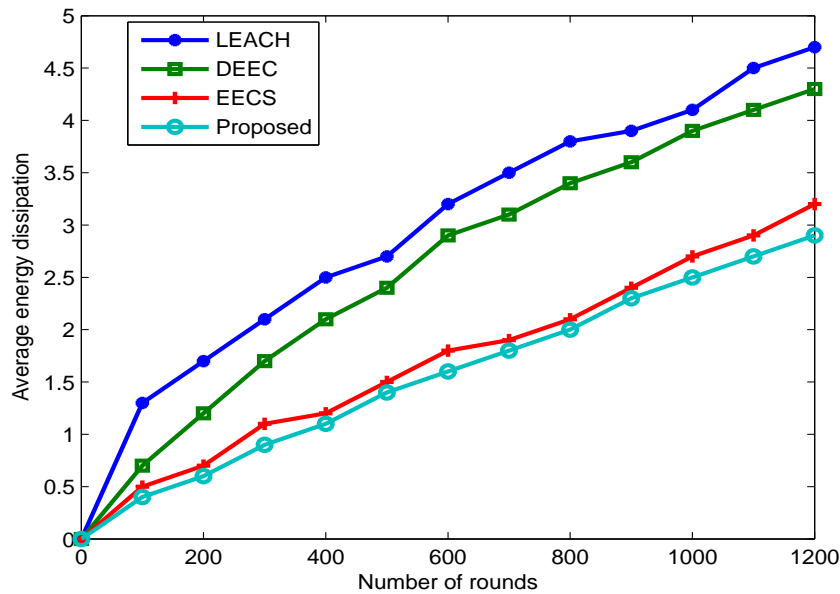

Figure 4.5: Average energy dissipation of the network versus number of rounds

#### 4.8.4 Study 4: Efficiency with respect to lifetime

The estimation of the lifetime of the network is a critical parameter to exhibit the productivity of the network. Figure 4.6 demonstrates that the proposed protocol outperforms the other existing ones with respect to the lifetime of the network. The staggered clustering protocol is contrasted with LEACH, DEEC and EECS in the same heterogeneous setting. Moreover, the lifetime of the network is considered in this protocol until 50% of the node stays alive. The proposed protocol chosen high energy nodes to be the cluster-head because of the availability of advanced nodes in the network. So it dodges earlier death of low energy nodes and draws out the stability of the wireless sensor networks.

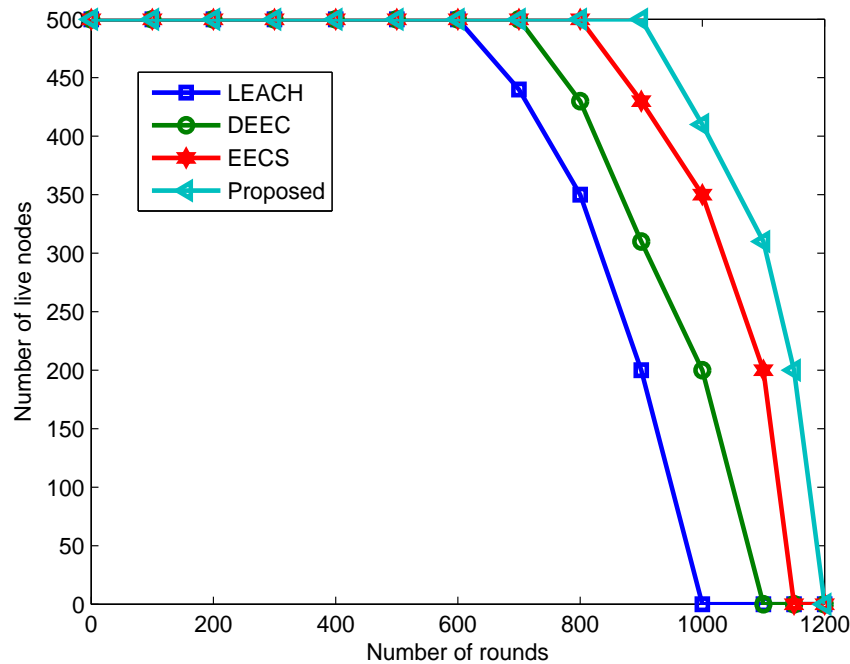

Figure 4.6: Lifetime of some selected algorithms

#### 4.8.5 Case 5: Case study for the use of Clustering in Wireless Brain Computer Interface

Wireless BCI frameworks can be used in practical applications, for example, house control system and drowsiness detection system for drivers. Recently, BCI has begun its approach to get the attention of the general public to show the possibility of another kind of user experience. For example, drowsiness detection can be applied to car drivers for preventing traffic accidents. The main aim of the wireless BCI framework is to maximize the lifetime of the network by using less amount of energy. So that, the network can work for maximum time without the replacement of the batteries. The BCI framework can be energy proficient by using the energy aware clustering protocols. The use of clustering protocols provide a lot a of benefits, for example, scalability, energy efficiency and throughput of the network.

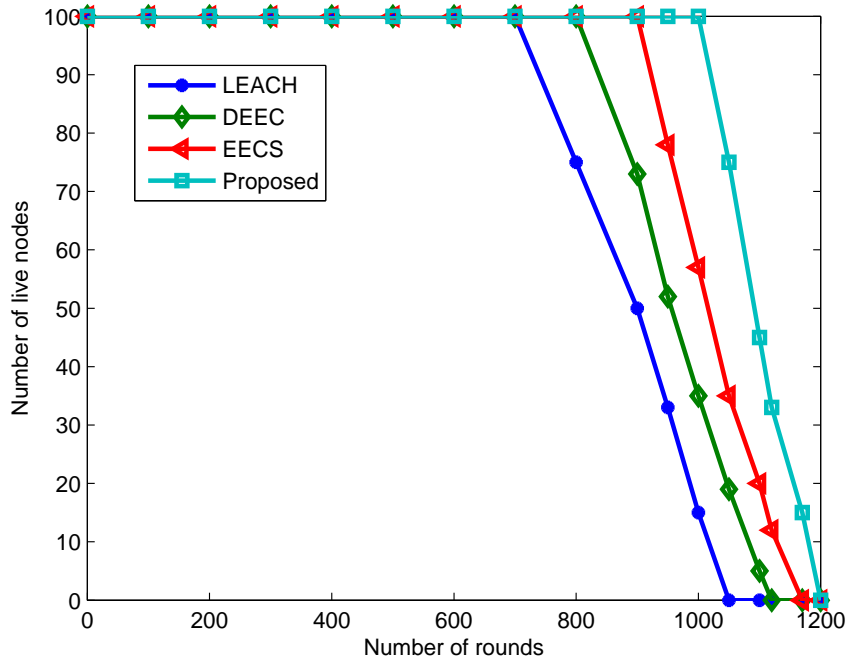

Figure 4.7: Lifetime of some selected algorithms on different settings (reduced number of nodes)

The proposed protocol is tested on a different simulation setting where area of the network is  $5 \times 5 \times 5 \text{ cm}^3$  and number of nodes are hundred with a structural deployment. Figure 4.7 shows the lifetime comparison of different protocols in the same simulation settings.

## 4.9 Summary

In this chapter, a staggered clustering protocol (SCP) for two-level heterogeneous wireless sensor networks has been proposed that accomplishes the energy efficiency of the network. The suggested protocol minimizes the expense of communication energy to increase the lifetime of the network. This protocol does not require any global energy knowledge during clustering process. As long as the nodes trade local information, the selection of

cluster-heads becomes easier. It relies upon the local information sharing like energy information and communication cost. Simulation results show better performance with respect to the impact of CH selection, cluster density and frequency of re-election. It may be noted that, the performance result with respect to cluster-head selection can be optimal to build an energy efficient network. This optimization process can be accomplished in further contribution.

## Chapter 5

# Energy Efficient Clustering Algorithm for Wireless Sensor Networks using Particle Swarm Optimization

---

[Energy optimization is explored by using PSO]

## 5.1 Introduction

Wireless Sensor Network (WSN) has become popular as an effective technological platform with huge and novel applications. It has turned into an important innovation in acknowledging numerous applications such as military applications, environment monitoring and surveillance systems. There are few factors that affect designing and working of WSNs. These factors incorporate energy efficiency, low latency, network coverage and load balancing in terms of energy used by sensor nodes [99]. Because of these unique attributes, it is a challenging task to select or propose a new clustering algorithm for a specific WSN application [100]. Utilizing clustering strategies in WSN can help solving some of those concerns, by organizing the network nodes into smaller clusters and elect a cluster-head. In cluster based protocols, the network operating time is divided into rounds. Each round consists of two phases, the cluster set-up phase and the data-communication phase. In the cluster set-up phase, the network is configured. The CH nodes and the clusters are determined, and each CH assigns a member node to a slot in order to create time-division multiple-access (TDMA) schedule. In the data-communication phase, each member node sends its data to its respective CH at the assigned time slot and the CH aggregates the data and forwards it to a central Base Station (BS) [101].

The decision of selecting CHs relies on a couple of segments, for instance, residual energy and neighbour density. Since the CH needs to stay active during the whole round, it may deplete its energy sooner than the other members of the cluster. So the role of cluster-head is periodically pivoted among the sensor nodes to ensure adjusted energy consumption. Since the CHs are continually dynamic during the whole round, minimizing the number of CHs will in turn decrease the energy consumption and increase the network lifetime [56]. Hence, the number of chosen CHs is an essential



element that influences the network lifetime fundamentally. The objective of clustering is to look among a group of sensor nodes to locate an arrangement of nodes that can act as cluster-heads. For a given network topology, it is hard to locate the ideal arrangement of CH nodes. For  $N$  sensor nodes, there are  $2^N - 1$  distinctive combination of solutions, where in each arrangement, a sensor node is either chosen as CH or non-CH. This has been ended up being a Non-deterministic Polynomial (NP)-hard optimization problem [100]. Solutions for NP-hard problems include searches through huge spaces of possible arrangements. Swarm intelligence methodologies have been applied effectively to a variety of NP-hard problems. Particle swarm optimization (PSO) is a swarm intelligence based optimization strategy. PSO has numerous advantages over different alternatives optimization techniques like Genetic Algorithms (GA). For instance, simplicity of execution on hardware or software, excellent solutions because of its capacity to escape from local optima and fast convergence [102]. In view of its adequacy in solving NP-hard problems, PSO has been adopted to optimize the CH election by several clustering protocols. Clustering is a rehashed procedure; in this way, the easier the optimization algorithm, the better the network productivity is. This is another reason PSO is a popular choice for WSN clustering.

The remainder of this chapter is organized as follows. The proposed system model is presented in Section 5.2. Section 5.3 provides a brief summary of PSO. Section 5.4 provides a detailed description of the proposed protocol. Simulations results are illustrated in Section 5.5. Finally, we summarize our work in Section 5.6.

## 5.2 System Modeling

Our proposed protocol relies on the following key realistic assumptions regarding the Wireless Sensor network:

### 5.2.1 Network Model

A set of sensor nodes is randomly spread throughout a two-dimensional square field. Also, no suspicions are made about the network density. We consider the following properties of the sensor network:

- The sensor nodes are static.
- There are two types of nodes are used, for example, normal nodes and advanced nodes.
- Communication links are bidirectional.
- The processing and communication capabilities are the same for all network nodes.
- The sensor nodes are unaware of their location.

### 5.2.2 Energy Model

In this protocol, we utilized the energy model used in [18] to gauge the energy dissemination for our network. The energy model comprises of a transmitter, power amplifier, and receiver. The energy model has two propagation models: 1) free space model and 2) multi-path fading model.

The transmitting power can be enhanced amid the transmission by the power amplifier to repay the propagation loss. Accordingly, the amount of energy required to transmit a  $b$  bit message from the source to destination at a distance  $d$  is characterized as:

$$E_{Tx}(b, d) = \begin{cases} b \cdot (E_{elec} + \epsilon_{fs} \cdot d^2), & \text{if } d < d_0, \\ b \cdot (E_{elec} + \epsilon_{mp} \cdot d^4), & \text{if } d \geq d_0 \end{cases} \quad (5.1)$$

Where  $E_{Tx}$  specifies the amount of energy disseminated for transmitting a data packet, but  $E_{elec}$  defines the energy dissipation per bit in transceiver hardware. The power amplifier parameter used for the free space propagation model is

$\in_{fs}$ . Whereas, for the multi-path propagation model the energy amplifier parameter  $\in_{mp}$  is used.

The amount of energy needed for accepting an  $b$  bit message is:

$$E_{Rx}(b) = bE_{elec} \quad (5.2)$$

### 5.3 Particle Swarm Optimization

Particle Swarm Optimization (PSO) is a stochastic population based optimization algorithm which is motivated by social behaviour of bird flocking or fish schooling [33]. The basic PSO comprises a swarm of  $S$  particles (potential solutions), which fly through a  $D$ -dimensional problem search space in search of the global optimum position that produces the best fitness of an objective function.

Initially, each particle  $i$  is randomly assigned a position  $x_{id}$  and a velocity  $v_{id}$  ( $i = 1, 2, \dots, S$ ), and  $d = (1, 2, \dots, D)$ . In every iteration, each particle adjusts its velocity to follow two best solutions. The first is the cognitive part, where the particle follows its own best solution found so far. This is the solution that produces the lowest cost (has the highest fitness). This value is called  $pbest_i$  (particle best). The other best value is the current best solution of the swarm, i.e., the best solution by any particle in the swarm. This value is called  $gbest$  (global best). After finding the two best values, particle  $i$  then updates both its position and velocity iteratively with the following equations:

$$v_{id}(t+1) = w \times v_{id}(t) + c_1 r_1 (pbest_i(t) - x_{id}(t)) + c_2 r_2 (gbest(t) - x_{id}(t)) \quad (5.3)$$

$$x_{id}(t+1) = x_{id}(t) + v_{id}(t+1) \quad (5.4)$$

The parameters,  $c_1$  and  $c_2$  are two positive constant named as learning factors. Whereas,  $r_1$  and  $r_2$  are random variables between  $[0, 1]$ . The parameter  $w$  is a weight factor that control the velocity of the particle. The PSO algorithm is shown below:

---

**Algorithm 3** PSO Algorithm

---

```

1: for each particle do
2:   initialize particle
3: end for
4: while target fitness or maximum epoch is not attained do
5:   for each particle do
6:     calculate fitness
7:     if current fitness value better than (pbest) then
8:       pbest = current fitness
9:     end if
10:  end for
11:  set gbest to the best one among all pbest
12:  for each particle do
13:    update velocity using equation 5.3
14:    update position using equation 5.4
15:  end for
16: end while

```

---

## 5.4 The Proposed Protocol

In this section, we discuss a distributed and PSO-based clustering protocol to create hierarchical cluster structure for the sensor nodes. The proposed energy efficient clustering algorithm using PSO (EEC-PSO) is trying to optimize the number of cluster-heads to minimize the energy consumption of the network.

In EEC-PSO, the network operating time is divided into rounds. Each round consists of two phases, (i) the cluster formation phase and (ii) the data communication phase.

### 5.4.1 Cluster Formation Phase

The primary objective of this stage is to locate the optimal set of CHs and form the clusters.

This phase begins with neighbour discovery where every sensor node broadcasts a HELLO packet that includes its ID. A sensor node that receives this HELLO packet will update its neighbour table with the ID included in the packet along with the Received Signal Strength Indicator (RSSI) [103] value in the received packet. After the neighbour discovery ends by all the sensor nodes, each node broadcast the ID, residual energy and its neighbour table data.

A particle is represented as a sequence of candidate cluster head ID's. Some of the nodes declare themselves as candidate nodes based on the RSSI value. Only nodes with an energy level above the average are eligible to be a CH candidate for each subsequent round except the beginning round. Next, any one of the candidate nodes voluntarily runs the PSO algorithm to find the best  $B$  CHs that can minimize the energy efficiency function.

1) *Particle Initialization*: In the proposed protocol, each particle's position vector that represents the CH nodes ID is initialized with random integer values. The particle size is equal to the upper bound on the number of CH candidates. It should be noted that the velocity update by equation 5.3 gives non-integer velocity values, which are converted to the nearest integer in the implementation.

Every node has the knowledge of RSSI value and energy information of all its neighbors. The nodes having highest RSSI value and energy than the neighbors declare themselves as a candidate cluster-head for the current round. From the set of candidate CHs, the node having the maximum RSSI strength will finally become the CH. At last, the final list of CH is informed to each member present in the network.

2) *Cluster Formation*: Rest of the nodes present in the network joins the nearest cluster-heads which are generated from the particles. We aim at designing the clusters with the objective of improving the network scalability and minimizing the number of CHs during each round.

3) *Objective Function*: The best CHs are selected such that they optimize the combined effect of the following properties: energy efficiency and link quality.

i) **Energy Efficiency:**

To achieve an energy efficient clustering protocol, less number of CHs need to be selected during each round. To achieve that, the protocol needs to minimize the number of CHs. Minimizing the following function will achieve that objective:

$$EE_p = \frac{B}{U} \quad (5.5)$$

$B$  is the total number of CHs generated from particle  $p$ .  $U$  is the upper bound on the number of CHs.

ii) **Link Quality:**

The aim of this sub-objective is to maximize the link quality between the cluster members and their respective CHs in order to maximize the Packet Delivery Rate (PDR). RSSI, strength of the received RF signal, is one fundamental indicator of link quality.

Let  $LQ(n_i, CH)$  be an indicator of the link quality between cluster member  $n_i$  and its  $CH$ . It can be calculated using:

$$LQ_{(n_i, CH)} = \frac{RSSI(n_i, CH)}{\min RSSI} \quad (5.6)$$

$RSSI(n_i, CH)$  is the RSSI for the link from  $n_i$  to  $CH$  and  $\min RSSI$  is the worst RSSI value among all communicating pairs.

After calculating the previous sub-objectives, the final objective function that needs to be minimized is:

$$wc_1 \times EE_p + wc_2 \times LQ \quad (5.7)$$

$w_{c_1}$  and  $w_{c_2}$  are weight coefficients that specify the contribution of each sub-objective in the main objective function.

4) *TDMA Scheduling*: The CHs create schedules based on TDMA to allocate time slots for each of the cluster members.

The energy efficient clustering algorithm using PSO is described in step-by-step manner in Algorithm 4.

---

**Algorithm 4** EEC-PSO Algorithm
 

---

- 1: Initialize  $S$  particles to contain  $K$  randomly selected cluster-heads among the eligible cluster-head candidates.
  - 2: For each node  $n_i$ ,  $i = 1, 2, \dots, N$
  - 3: Calculate distance  $d(n_i, CH_t)$  between node  $n_i$  and all cluster-heads  $CH_t$ .
  - 4: Assign node  $n_i$  to cluster-head  $CH_t$  where;
 
$$d(n_i, CH_t) = \min_{t=1,2,\dots,K} \{d(n_i, CH_t)\}$$
  - 5: Find the personal and global best for each particle.
  - 6: Update the particle's velocity and position using equation 5.3 and 5.4
  - 7: Map the new updated position with the closest (x,y) coordinates.
  - 8: Repeat steps 2 to 7 until the maximum number of iterations is reached.
- 

### 5.4.2 Data Communication Phase

In the data-communication phase, each member node uses its TDMA schedule to transmit its data to its cluster-head. When a member node finishes its data transmission slot, it enters the sleep state to save its energy until it receives any new data.

Table 5.1: Simulation parameters

<i>Parameter</i>	<i>Value</i>
Area	$500 \times 500$
Nodes	500
Base Station	(250,250)
Initial Energy (normal node)	2J
$E_{elec}$	50nJ/bit
$\epsilon_{fs}$	10pJ/bit/ $m^2$
$\epsilon_{mp}$	0.0013pJ/bit/ $m^4$
$E_{DA}$	5nJ/bit/message
Packet Size	2000 bits
Frames/round	30

## 5.5 Simulation and Result discussion

We simulate a wireless sensor network of 500 nodes in a  $500 \times 500 m^2$  area, and the base station is placed in the middle of the zone. The simulation parameters are indicated in Table 5.1. It is assumed that there are  $p$  percentage of advanced nodes outfitted with  $\alpha$  times more energy as compared to the normal nodes that are present in the network. The starting energy of each of the normal node is 2J, but in case of advance nodes it is  $2(\alpha+1)J$ . In this simulation, we assumed the value of  $\alpha$  as 2. The performance of the proposed algorithm is investigated against the well known protocols LEACH, DEEC, EECS and PSO-HC.

### Case 1: Robustness with regard to number of clusters

Figure 5.1 exhibits the amount of cluster-heads made in each round. The number of CHs selected in each round is not equal. According to the



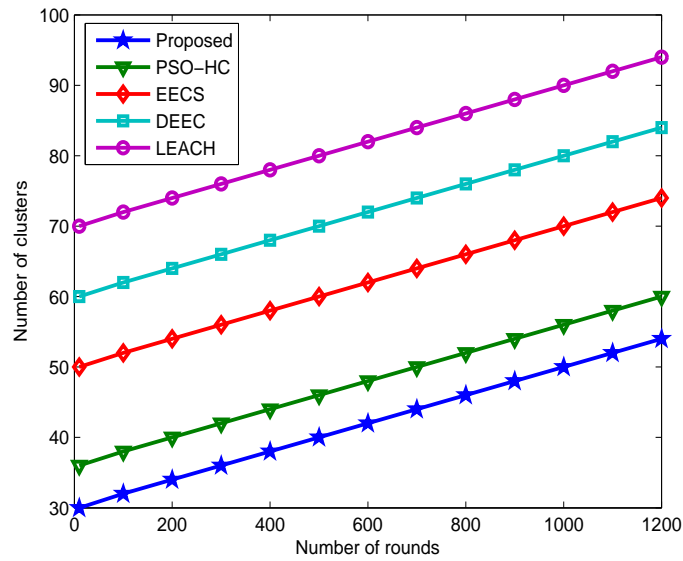

Figure 5.1: Number of Cluster-heads per round

transmission range and available energy of a node, the clusters are created. If any node doesn't come under the close proximity of any CH then that turns into an isolated CH. Furthermore, the lifetime of the network is very subject to the number of cluster-heads appointed. At the point when the number of cluster-heads is more, it consumes a lot of energy in data forwarding, which decreases the lifetime of the network.

## Case 2: Efficiency based on energy consumption

Figure 5.2 demonstrates that the proposed protocol is more energy efficient than LEACH, DEEC, EECS and PSO-HC. Residual energy is the amount of energy left with the node. The node that is having more residual energy will have more opportunities to turn into a CH. In heterogeneous networks, the advance nodes have more opportunity to be the cluster-head so that the lifetime of the network will be expanded. This protocol gives better performance when contrasted with other existing ones due to the energy efficiency parameters used for data transmission. Determination of high

energy node with low communication cost remain the key parameter for achieving energy efficiency in the protocol.

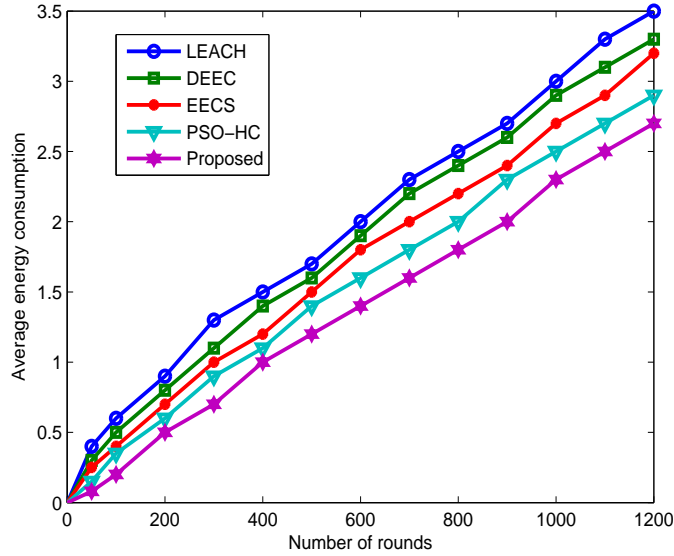

Figure 5.2: Average energy dissipation of the network versus number of rounds

### Case 3: Efficiency with respect to lifetime

The estimation of the lifetime of the network is a critical parameter to exhibit the productivity of the network. Figure 5.3 demonstrates that the proposed protocol outperforms the other existing ones with respect to the lifetime of the network. The staggered clustering protocol is contrasted with LEACH, DEEC, EECS and PSO-HC in the same heterogeneous setting. Moreover, the lifetime of the network is considered in this protocol until 50% of the node stays alive. The proposed protocol selects high energy nodes to be the cluster-head because of the availability of advanced nodes in the network. So it dodges earlier death of low energy nodes and draws out the stability of the wireless sensor networks.

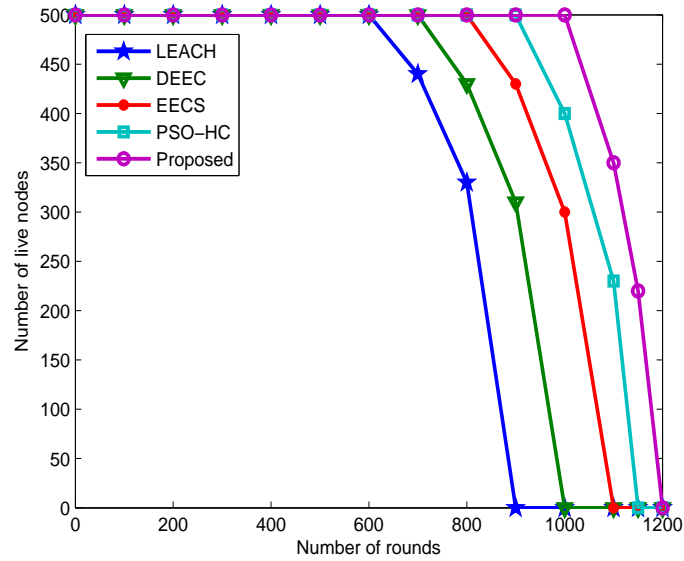

Figure 5.3: Lifetime of the algorithms

#### Case 4: Case study for the use of clustering in wireless Brain Computer Interface

Wireless BCI frameworks can be used in practical applications, for example, house control system and drowsiness detection system for drivers. Recently, BCI has begun its approach to get the attention of the general public to show the possibility of another kind of user experience. For example, drowsiness detection can be applied to car drivers for preventing traffic accidents. The main aim of the wireless BCI framework is to maximize the lifetime of the network by using less amount of energy. So that, the network can work for maximum time without the replacement of the batteries. The BCI framework can be energy proficient by using the energy aware clustering protocols. The use of clustering protocols provide a lot a of benefits, for example, scalability, energy efficiency and throughput of the network. The lifetime of the proposed protocol can be tested on a different simulation setting, where area of the network is  $5 \times 5 \times 5 \text{ cm}^3$  and number of

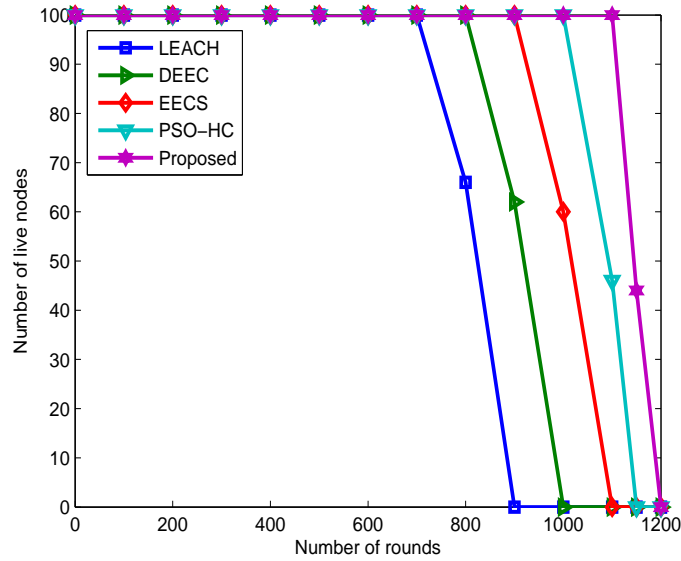

Figure 5.4: Lifetime of some selected protocols on different simulation settings

nodes are hundred with a structural deployment. Figure 5.4 shows the lifetime comparison of some selected protocols in the different simulation settings.

## 5.6 Summary

In this chapter, a PSO based energy efficient clustering protocol has been proposed for designing WSNs. The suggested protocol enhances the network energy efficiency by fixing an upper bound for the number of CHs. The optimization method minimizes the number of CHs as mapped to that fixed bound value. Furthermore, it improves the network scalability by utilizing heterogeneous cluster structure. The protocol has been tested on an energy consumption model that can be viewed as a realistic network. The empirical simulations has been conducted to achieve the adequate performance. The simulation results outperform its competent approaches. The current suggested protocol comprises all the achieved advantages of preceding

approaches. This optimized approach can be applied in brain computer interface (BCI) to enhance the lifetime of the sensor network used in the interface. Subsequently, the BCI detects drowsiness of the driver on wheel that uses the proposed scheme.

## Chapter 6

# An Application of Wireless Brain Computer Interface for Drowsiness Detection

---

(Use of wireless sensor network in brain computer interface)

## 6.1 Introduction

Brain computer interface (BCI), typically understood as networks of wearable or implantable wireless devices designed to interpret the brain signals by the computer. The biomedical devices are implanted or worn by the humans to collect diagnostic information, which will fine-tune medical treatments or biomedical applications over extended periods of time [104]. This chapter aims to detect the drowsiness of the drivers on wheel by utilizing the wireless brain computer interface. Driver's drowsiness has been embroiled as a causal element in numerous mischances due to the stamped decrease in drivers' ability to detect danger and distinguishment of risk [83]. Drowsiness is move state in the middle of getting up and slumber, amid which a diminishing of vigilance is achieved. Drowsy driver recognition framework helps in reducing the number of accidents caused by the drowsy drivers. The National Highway Traffic Safety Administration (NHTSA) reported that drowsy driving causes more than 100,000 accidents a year, bringing about 40,000 wounds and 1,550 passings [105]. As per a study from National Sleep Foundation (NSF), 37 percent of individuals said that, they had fallen asleep on the wheel, and 13 percent said they did so once a month. Youthful grown-ups aging 18 to 29 are more inclined to say they've driven drowsy (71 percent), contrasted with generally 50% of grown-ups aging 30 to 64. To be sure, it is evaluated that more youthful drivers represent very nearly two-thirds of drowsy driving accidents. Men are more prone to drive drowsy than ladies (56 versus 45 percent) and are very nearly twice as prone to nod off at the wheel [106].

Previous studies have proposed various strategies to discover drowsiness driving by focusing on blink rate, eye closure, and inclination of driver's head. There are a few signs of drowsiness that ought to advise a driver to stop and rest. It is watched that, the parameter like overwhelming eyelids are

effectively fluctuating in distinctive vehicle sorts and driving conditions [79]. The primary focus on measuring physical changes of the driver, such as pulse rate, heartbeat rate, eye blinking measures and electroencephalographic (EEG) activities to detect drowsiness and alert the driver before meeting an accident [80]. Orden *et al.* [107] showed the comparison between the EEG-based methods with the eye activity based method for detection of drowsy driving.

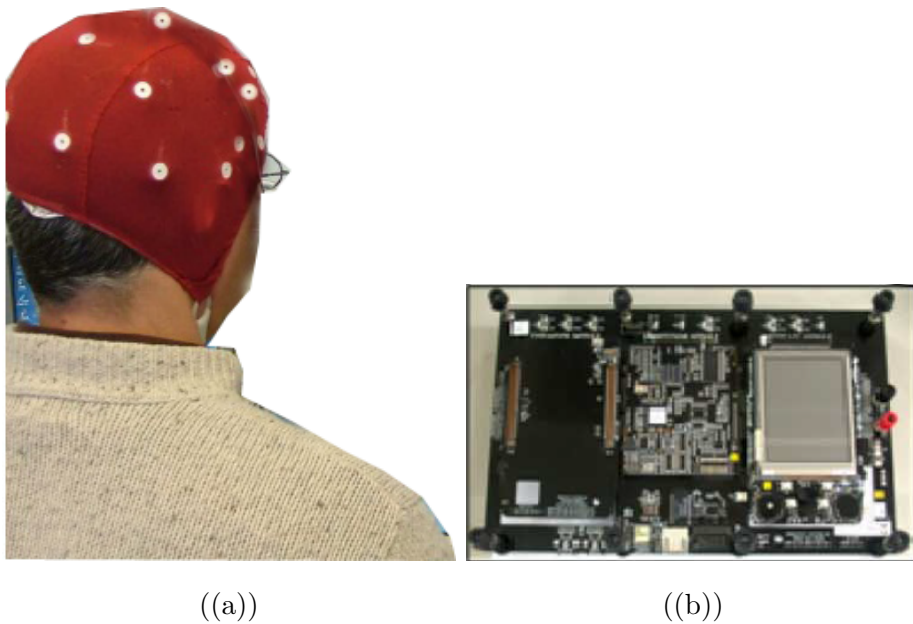

Figure 6.1: Photographs of (a)Wireless braincap used for signal acquisition (b) Signal processing module

This chapter describes a quick distinguished EEG-based wireless brain computer interface scheme for detecting the drowsiness. There exist a couple of approaches to detect drowsiness by using wired BCI communication. The wired BCI is found to be unsuitable when there is a need of movement for the BCI application. The proposed wireless BCI model comprises of a braincap, signal acquisition unit, and a signal processing module. The braincap as shown in Figure 6.1(a) is utilized to gather EEG signals continuously, which will be further processed by the signal processing module



as shown in Figure 6.1(b).

The rest of the chapter is organized as follows:

The system modeling of BCI is described in Section 6.1.1. Section 6.2 depicts the network model of the proposed framework. The drowsiness detection and issuance of warning tone is discussed in Section 6.3, followed by Section 6.4, where the results are being discussed. Finally, the chapter is summarized in Section 6.5.

### **6.1.1 System Model**

A general working model of the proposed wireless brain computer interface is demonstrated in Figure 6.2. The brain signals are captured through the braincap mounted EEG sensors. The EEG signal acquisition unit(SAU) handles getting the signal from the braincap, and it will send digital information to the signal processing unit(SPU) after the necessary filtration and amplification of the signal followed by an analog to digital converter. Then, it is the job of the SPU to take the decision, whether warning tone should be triggered or not. The two parts of the SAU are analog and digital. In the analog stage, bandwidth filtering and amplification are two main components needed for getting accurate and useful signal. Due to the low amplitude of the EEG signal, amplification is very much required for further processing. The digitized signal is then processed through the microprocessor to check the bit errors. At last, the signal is transmitted through a wireless transmitter to the signal processing unit.

Furthermore, a clustering algorithm can be used for the total number of sensors used in the braincap. This will help to enhance the longevity of the sensors mounted on the braincap. In this phase, on the basis of location information and the energy power of the sensors the cluster-heads are selected periodically. The CHs are the only responsible nodes to send the sensed data to the base station (BS). In this way, we can save the energy of the cluster

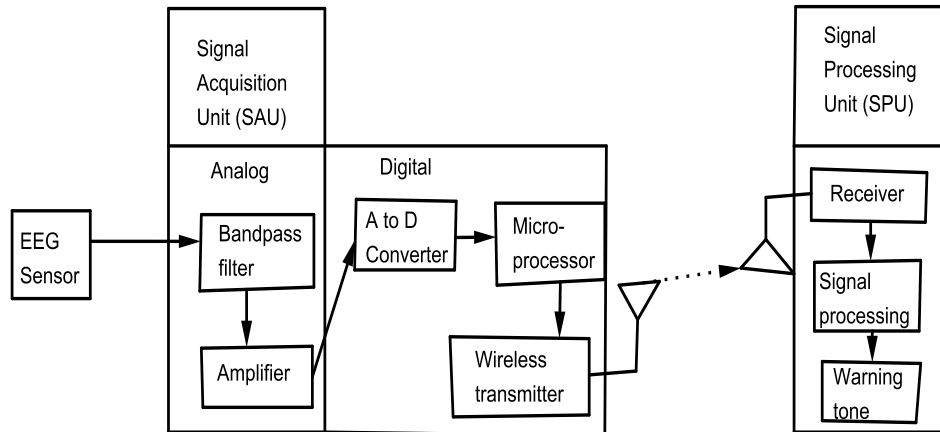

Figure 6.2: Working model of wireless BCI System

member nodes which help in enhancing the lifetime. As per the principle of the proposed algorithm, after the selection of the CHs, the neighbor nodes try to become cluster member by sending request to join them. Then the CHs decide which node to be their member. Thus the clusters are formed with one cluster-head and one or more cluster members. After the end of the clustering process if any node stays alone without becoming a member of any cluster, then it becomes an isolated cluster-head.

### 6.1.2 Wireless EEG Signal Acquisition Unit

The EEG signals are collected from the electrodes fitted with the braincap worn by the driver. The signal is recorded as unipolar by taking the left ear as a reference point. The EEG signals collected from the braincap are sampled at a rate of 256 Hz utilizing a bandpass filter of 0.1–100 Hz [108]. We likewise require a frequency filtering strategy to evacuate different noise components. The recorded EEG signals possess a narrow bandwidth (0.1 Hz to 50 Hz). Subsequently, filtering is useful for concentrating on valuable signals from the raw signals. To channel out unwanted frequency bands, the analog system uses a bandpass filter. Those filtering procedures are performed

utilizing inactive or dynamic filtering circuits.

In the amplification process, the wireless BCI framework uses operational amplifiers or instrumentation speakers. Those amplifiers ordinarily give an increase in signal strength going from thousands to many thousands. Amplification with high gain gives more prominent heartiness against a variety of clamor sources. Then again, we have to focus a suitable amplification increase to boost the signal determination in the simple analog to digital converter (ADC). In this way, the amplification process helps in transmitting a higher bandwidth signal to the digital system of the framework.

In the digital framework, four components are incorporated: a multiplexer, a microprocessor, an ADC and a remote transmission unit. For the most part, most EEG-based wireless BCI frameworks help multi-channel recording [35, 84]. To utilize multi-channel signals at the same time, a multiplexer is required to get access to all the channels. Since the measured EEG signals are of analog type, an ADC must be incorporated to process the recorded EEG information on the digital circuits. This integrated circuit changes the EEG analog signals into discrete digitized information with a particular sampling frequency. The Bluetooth module is most generally utilized as a part of medicinal applications, where the transmission distance is up to 10 meter. In this application, we also utilized bluetooth as the transmission between the wireless transmitter and the receiver.

### **6.1.3 EEG Signal Processing Module**

The EEG signal processing module is used to pre-process the received signal. It can perform different calculations to help peripheral interfaces. The module comprises of three submodules, for example, a recipient module, signal transforming module and a warning tone unit. The responsibility of the signal processing module is to process and analyze the received EEG

data. The warning tone generates an indication for the driver when the drowsy state is caught. The Blackfin processor (ADSP-Bf533) can be utilized as a part of the implanted signal processing module. The CPU speed of the installed Blackfin processor is measured up to 600 Mhz. The processor utilizes different signal processing algorithms to measure the strength of the received EEG signals. However, the warning signal is generated when the value reaches the threshold.

## **6.2 Network Model**

For our proposed wireless sensor network, following are the few assumptions,

- All sensor nodes are uniformly deployed over the braincap.
- Each node in the network is static.
- Each node is capable enough to increase their transmitting power upto a threshold value when they are appointed as a cluster-head.
- The responsibility of acting as a cluster-head changes dynamically.
- The base station is deployed within one meter region from the application area, which is nearby the driver's seat.
- Every node present in the network sends the sensed data to their respective cluster-heads, and the CHs convey the data straightforwardly to the BS.
- The cluster-heads aggregate the received data from all it's member nodes and forward to the base station as a single packet.

### 6.2.1 Energy Dissipation Model

The energy dissipation model utilized in this algorithm is followed from [18]. The amount of energy required to transmit a  $b$  bit message from the source to destination at a distance  $d$  is characterized as:

$$E_{Tx}(b, d) = \begin{cases} b \cdot (E_{elec} + \epsilon_{fs} \cdot d^\alpha), & \text{if } d < d_0, \\ b \cdot (E_{elec} + \epsilon_{mp} \cdot d^\alpha), & \text{if } d \geq d_0 \end{cases} \quad (6.1)$$

Besides, The amount of energy needed for accepting an  $b$  bit message is:

$$E_{Rx}(b) = b \cdot E_{elec} \quad (6.2)$$

Here,  $E_{elec}$  defines the energy dissipation per bit in transceiver hardware, and  $\epsilon_{fs}$  (free space) or  $\epsilon_{mp}$  (multi-path fading) is the amplifier energy. In the event that the distance  $d$  between the source and the destination is bigger than the traverse distance  $d_0$ , the multi-path propagation model is utilized. Something else, the free space model is utilized to quantify the energy dissolution.

### 6.2.2 Clustering Strategy

The lifetime of the clustered WSN depends on the measure of time the nodes stay alive. The sensing scope of the network varies depending on the number of live nodes. The lifetime of this proposed wireless BCI is characterized as the time for which the *Effectiveness* is at the very least 70% [109]. The wireless sensor network is fully effective when all of the sensor nodes are alive and they cover the entire region of interest.

$$Effectiveness = \sqrt{\frac{x \cdot N'}{y \cdot N}} \quad (6.3)$$

Where,  $x$ =Area covered

$y$ =Total area

$N'$ =Surviving nodes

$N$ =Total number of nodes

The lifetime of the wireless sensor network is defined as the weighted sum of the lifetime of the individual sensors present in the network. In an active monitoring like application, the primary job of the sensors is to sense the data and transmit it for further processing. In the processing of the sensor network, the energy is consumed when the sensor sends or receives a message. The lifetime of the individual sensor is calculated by using the following equation,

$$L_j = \frac{E_j - \sum (\epsilon_{rcv} + \epsilon_{snd})}{E_j} = 1 - \frac{\sum (\epsilon_{rcv} + \epsilon_{snd})}{E_j} \quad (6.4)$$

Where,  $\epsilon_{rcv}$  is the amount of energy consumed when the sensor receives a message and  $\epsilon_{snd}$  is the energy consumed on sending a message. The lifetime of the whole network can be calculated as,

$$L_N = \sum_{j=1}^n w_j L_j \quad (6.5)$$

Weight =  $w_j = c \frac{1}{d_{jib}^2}$ , where  $c$  is a constant.

$d_{jib}$  : Distance from  $j^{th}$  sensor to the base station at  $i^{th}$  moment.

$n$  : Total number of sensor nodes present.

To increase the number of living nodes of the network, the energy dissipation rate of ought to be minimized. Accordingly the average energy  $A_{energy}$  consumption is characterized as,

$$A_{energy} = \frac{1}{N} \sum_{j=1}^N E_j^C \quad (6.6)$$

Here,  $E_j^C$  specifies the amount of energy consumed by node  $j$  during one round of the clustering algorithm. The energy consumption rate for cluster-heads and member nodes are different. In case of member nodes,  $E_j^C$  is only calculated based on the amount of energy required for transmitting data packets to the cluster-head. Whereas,  $E_j^C$  is calculated for cluster-heads by including the energy consumed for receiving data packets, the energy consumed for aggregating the received data packets and the amount of energy required for transmitting the data packets towards the signal processing unit.

$$E_j^C = \begin{cases} b_r \cdot (E_{elec} + E_{amp}) & \text{if node} \neq CH \\ b_r \cdot [E_{elec} + (n_j + 1) \cdot E_{DA} + E_{elec} + E_{amp}] & \text{if node} = CH \end{cases} \quad (6.7)$$

$$b_r = b \cdot n_{Tx} \quad (6.8)$$

Here,  $b$  specifies the length of the data packet, and  $n_{Tx}$  defines the actual number of transmissions occurred for a particular round. The total number of bits transmitted in a given round is shown as  $b_r$ . Whereas,  $n_j$  determines the amount of member nodes associated with node  $j$ , and  $E_{DA}$  ascertains the amount of energy needed for data aggregation. The amplifier energy can be classified as  $E_{amp} = \epsilon_{fs} d^2$  or  $\epsilon_{mp} d^4$ .

### 6.3 Drowsiness Detection and Warning Process

The wireless BCI framework proposed in this chapter is intended for drowsiness detection by consolidating the EEG data acquisition process and signal processing module. Consequently, a constant drowsiness detection technique joined with an online cautioning system is actualized in the created BCI framework for an exhibit. An element working environment is additionally developed to test and check the vigor of the BCI framework. The EEG range are for the most part arranged into two type,  $\alpha$  type (8–13 Hz) and  $\beta$  type (>13 Hz) [110]. In the initial stage of driving, the driver stays alert under any circumstances. The threshold value for the driver can be decided at the beginning stage of the EEG recording. It is always difficult to determine the threshold upon which the warning tone will be triggered. The threshold may change from time to time as per different working areas. For the best result, we have used the Mardia's test [111] for deciding the

threshold value. The warning tone generation process of the is demonstrated in Figure 6.3.

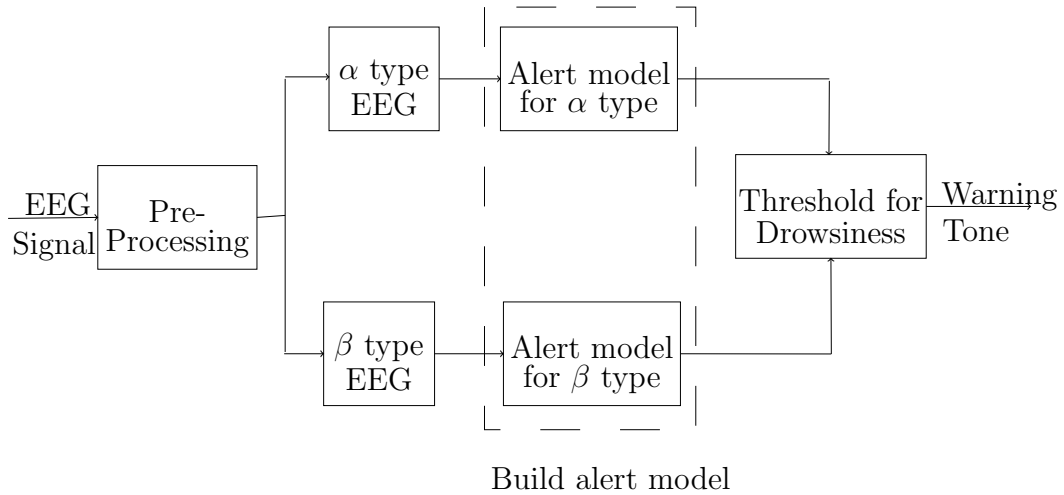

Figure 6.3: Work flow of the algorithm

### 6.3.1 Alert Model

The alarm model utilized in our scheme is designed by using the multivariate normal distribution model. In this algorithm, we use the received EEG signal after each 3 minutes of an interval to deduce the alert model. The multivariate normal distribution  $N(\mu, \Sigma^2)$ , where  $\mu$  is the mean vector and  $\Sigma$  is the variance-covariance matrix, is used for the derivation of the alert model. The value of  $\mu$  and  $\Sigma^2$  are appropriately taken to get better result during evaluation of EEG signals. In the wake of discovering the alert model, the type of EEG signal is classified either as  $\alpha$  type or  $\beta$  type. There are different models built for both the type of EEG signal. In the event that the alert model finishes Mardia's test [111], the alert model is finalized. Otherwise, the Mardia's test will be performed subsequently for the next three minutes of EEG recordings. Once the alert model is decided, then the warning tone will be triggered based on the comparison between the sensed EEG signal and the alert model.



$$\alpha_{alert} = \sqrt{\frac{(\alpha_{eeg} - \mu)}{\sum^2} \cdot (\alpha_{eeg} - \mu)} \quad (6.9)$$

$$\beta_{alert} = \sqrt{\frac{(\beta_{eeg} - \mu)}{\sum^2} \cdot (\beta_{eeg} - \mu)} \quad (6.10)$$

The aggregated deviance (totaled abnormality) value ( $ad_{val}$ ) for drowsiness recognition is computed focused around the direct mix of  $\alpha_{alert}$  and  $\beta_{alert}$  values.

$$AD_{val} = x \cdot \alpha_{alert} + (1 - \alpha) \cdot \beta_{alert}, \quad 0 \leq x \leq 1 \quad (6.11)$$

where  $x$  is a constant.  $\alpha_{alert}$ ,  $\beta_{alert}$ , and  $AD_{val}$  are combined used to detect the drowsiness. Finally, based on the observation of these three parameters the *threshold* value is decided.

### 6.3.2 Drowsiness detection algorithm

The ongoing drowsiness detection algorithm is actualized in the signal handling unit. The digitized EEG information is received from the EEG obtaining unit by the beneficiary at the signal processing unit. The multivariate normal distribution is used to deduce the alert model amid the initial three minutes of the received EEG signal. The EEG signal is classified into two types, for example,  $\alpha$  and  $\beta$  type to compute the deviance value from the real. After each one time the aggregated deviance ( $ad_{val}$ ) is calculated, it is checked with the threshold. On the off chance that the  $ad_{val}$  is more prominent than the threshold then a warning tone is activated. The working model of the drowsiness detection algorithm is shown as a flow chart in Figure 6.4.

Outlining energy efficient and reliable clustering protocols is profoundly essential for a resource-constraint wireless sensor network (WSN). Every cluster has a cluster-head, which organizes all the nodes of a cluster. During

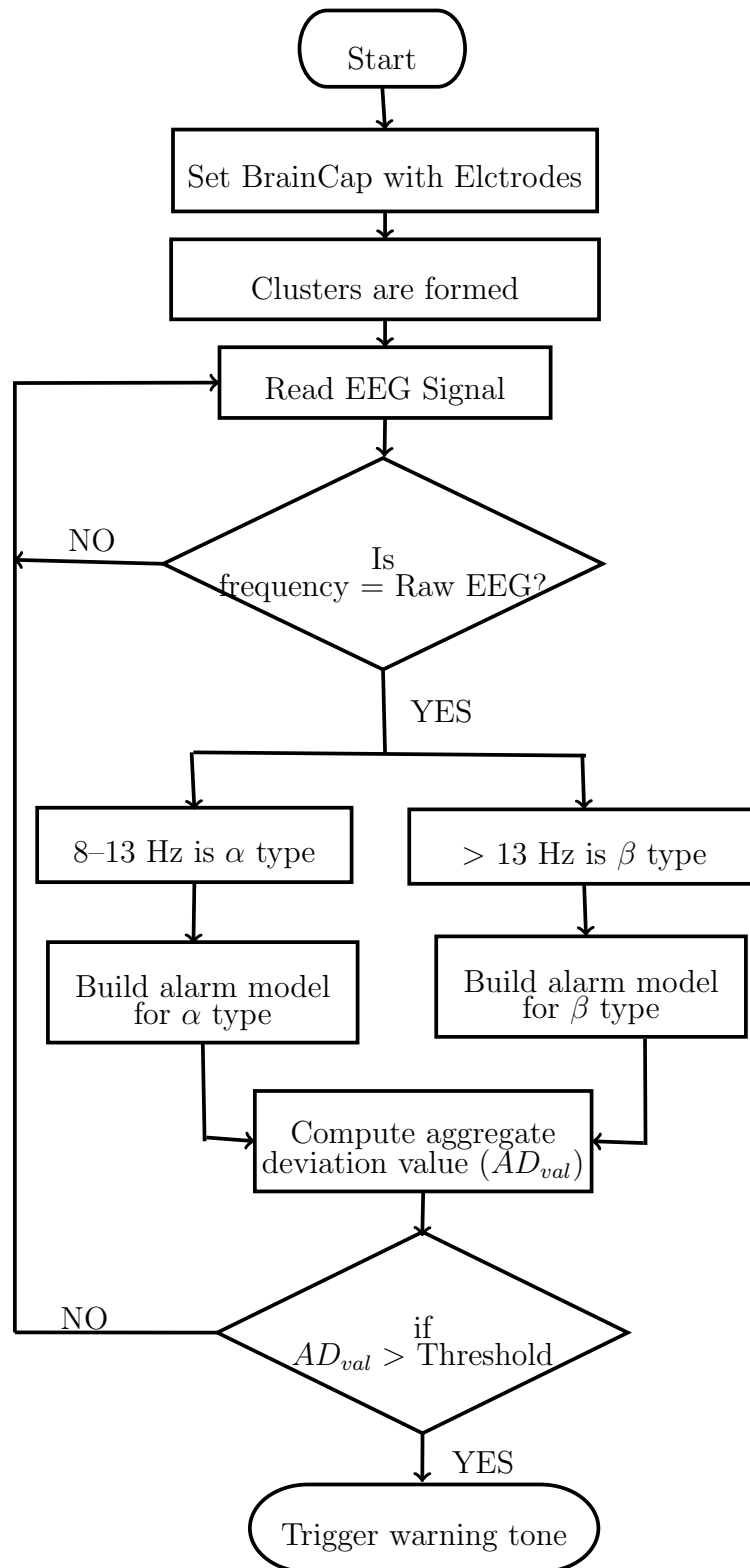

Figure 6.4: Flowchart of drowsiness detection methodology

clustering approach, all the sensor nodes in the communication range of the CH constitutes a cluster. The role of the clustering-based approach is to minimize the quantity of nodes that take part in long distance communication. Thus, it reduces the energy consumption of the network. In clustering protocols, CHs produces a single data packet from a large amount of raw data that are sensed by the member nodes of a cluster. It requires less amount of energy to transmit the precise and non-redundant information to the BS of the network. Due to the limited bandwidth, energy, storage capacity, and processing speed of the sensor nodes, designing an energy-efficient clustering protocol is an important issue in WSN.

## 6.4 Results and Discussions

The proposed wireless BCI is intended for continuous evaluation of EEG signals to detect the drowsy state and to trigger of warning tone. Subsequently, putting electrodes on the braincap is a doable and advantageous methodology for driver's drowsiness detection. Out of all the electrodes present on the cap, one is considered as a common ground electrode connected to the ground power supply. The EEG signals used in this algorithm are collected from the rest of the nodes.

### 6.4.1 Experimental Results

The simulation parameters for the proposed model is showcased in Table 6.1. The area of the network is  $5 \times 5 \times 5 \text{ cm}^3$  decided based on the assumptions taken by Liao *et al.* [112]. The use of clustering in wireless BCI was a challenging problem. In BCI applications, the sensing area is too small, so number of sensors are also less. We have applied the clustering algorithm for such a small network. The performance comparison of the clustered network in terms of number of data packets is shown in Figure 6.5.

Table 6.1: Simulation parameters

Parameter	Value
Area	$5 \times 5 \times 5 \text{ cm}^3$
Nodes	100
Initial Energy	2J
$E_{elec}$	50nJ/bit
$\epsilon_{fs}$	10pJ/bit/ $m^2$
$\epsilon_{mp}$	0.0013pJ/bit/ $m^4$
$E_{DA}$	5nJ/bit/message
Packet Size	1000 bits
Frames/round	30

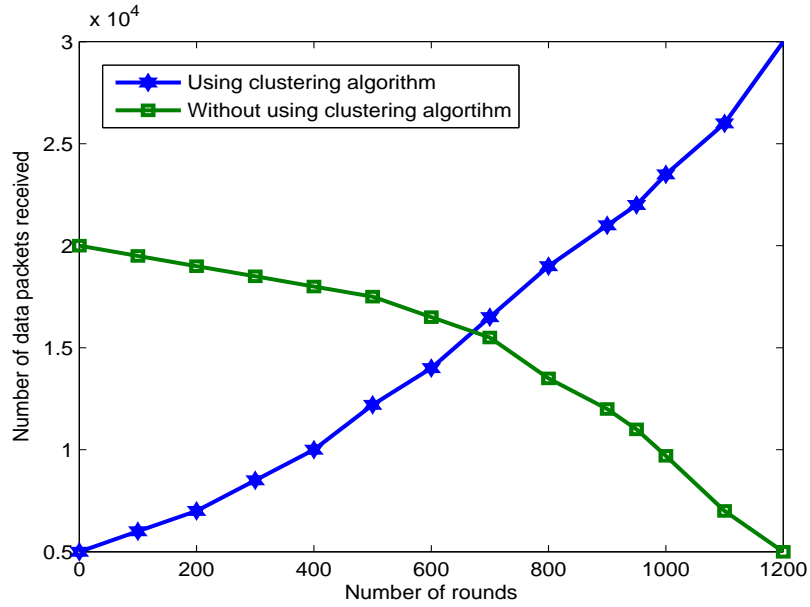

Figure 6.5: Comparison based on number of data packets received at base station

Another important parameter for any network is the lifetime of the network. The network lifetime is calculated based on the number of live nodes present in the network. Figure 6.6 shows the variability of the lifetime of different protocols. All these protocols are tested on the same simulation setting to

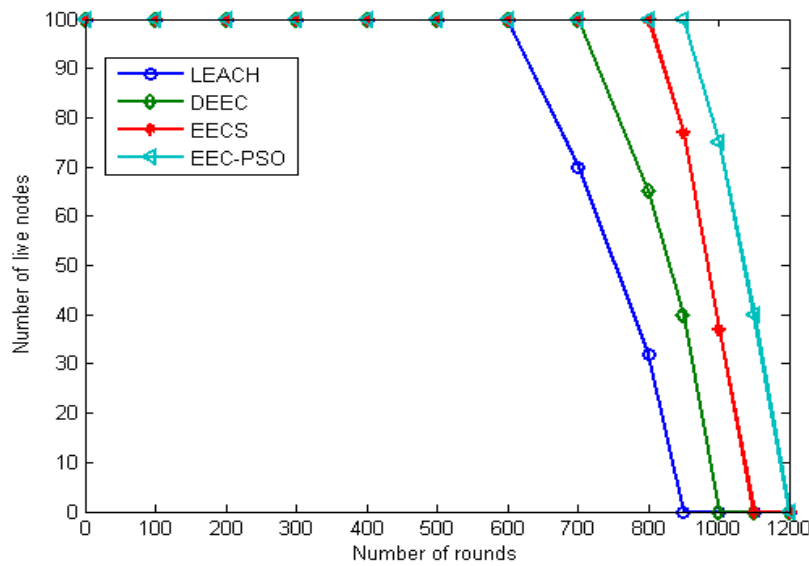

Figure 6.6: Lifetime comparison between different protocols

measure the lifetime of the network.

### 6.4.2 Drowsiness Detection

To classify active and drowsy states of a person effectively, a binary classification test has been performed. The EEG data used for the drowsiness detection has been taken from the dataset created by the multimedia signal processing group of Swiss Federal Institute of Technology, Switzerland. Hoffmann *et al.* [113] have build the dataset to observe disabled subjects for a longer time by utilizing brain computer interface. They have collected the EEG data in four different sessions.

The performance of binary classification test is evaluated using the confusion matrix which is shown in Figure 6.7. A confusion matrix for a two-class problem has following entries.

- True positive (TP) : predicted to be drowsy when the person is in drowsy state.

- False positive (FP) : predicted to be drowsy when the person is in active state.
- True negative (TN) : predicted to be active when the person is in active state.
- False negative (FN) : predicted to be active when the person is in drowsy state.

		Active state	
		p	n
Drowsy state	Y	TP	FN
	N	FP	TN
		Total : p	N

Figure 6.7: Confusion matrix

There are four important metrics used for performance evaluation of classification test that are derived from the entries of confusion matrix. The metrics are true positive rate ( $TPR$ ), false positive rate ( $FPR$ ), positive predictive value ( $PPV$ ), and  $F1 - score$ . The  $TPR$  and  $FPR$  are two most important metrics for evaluation of performance achieved by classification test. The  $TPR$  is defined as the fraction of drowsy state predicted correctly by the system. Similarly, the  $FPR$  is the fraction of active state predicted as drowsy state. For an ideal performance the  $TPR$  should be high. The  $PPV$  determines the percentage of drowsy state in case of drowsiness test. To classify active and drowsy states efficiently,  $F1 - score$  is used to find out the threshold for drowsiness detection. It is the harmonic mean of  $PPV$  and  $TPR$ . The definition of all these metrics are given below.

$$TPR = \frac{TP}{TP+FN},$$

$$FPR = \frac{FP}{FP+TN},$$

$$PPV = \frac{TP}{TP+FP}, \text{ and}$$

$$F1 - score = 2 \times \frac{PPV * TPR}{PPV+TPR}$$

In this work, the performance evaluation has also been accomplished with the help of a receiver operating characteristics (ROC) curve as shown in Figure 6.8. The ROC curve is a two dimensional graph which specifies TPR-FPR trade-off. The ROC curve shows that the drowsiness detection in this model works with the considerable amount of accuracy.

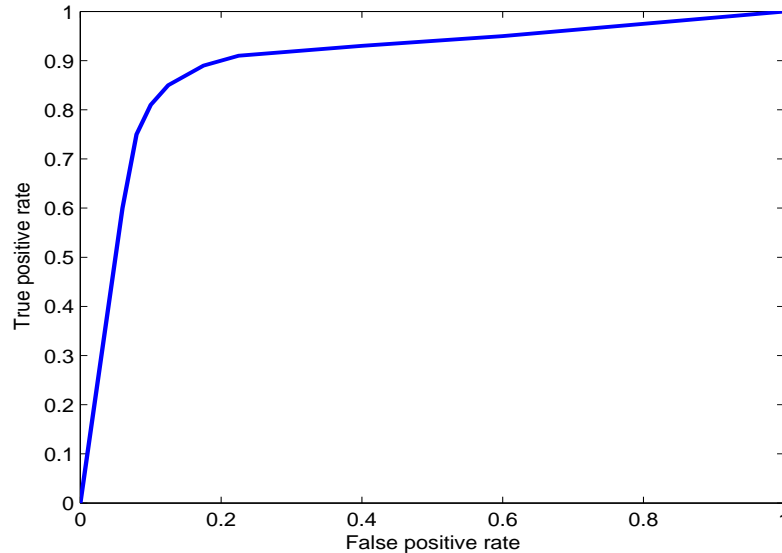

Figure 6.8: Receiver Operating Characteristics (ROC) for drowsiness detection

Furthermore, ten subjects' EEG signals and the threshold for drowsiness detection for testing sessions were used to test the reliability of this system. The result of the testing session for drowsiness detection was listed in Table 6.2. It showed that most of the true positive rate of drowsiness detection was between 75% and 88%. The average of F1-score of ten subjects is 84%. Here, higher  $TPR$  of our system can help drivers avoid traffic accidents more effectively.

Table 6.2: Different parameters for drowsiness detection

Subjects	F1 score (%)	TPR (%)	FPR (%)
1	78.5	77.4	22.6
2	79.7	82.1	17.9
3	85.2	87.3	12.7
4	84.1	81.5	18.5
5	89.7	90.0	10.0
6	85.3	82.3	17.7
7	88.8	87.2	12.8
8	79.0	75.8	24.2
9	86.8	85.4	14.6
10	91.0	88.5	11.5
Average	84.8	83.7	16.3

## 6.5 Summary

In this chapter, an wireless brain computer interface (BCI) utilizing PSO based energy efficient clustering protocol has been proposed to recognize the drowsiness in automobile applications. The interface comprises of an EEG signal acquisition unit and a signal processing unit. The real time EEG signals are captured by the signal acquisition unit and transmitted wirelessly to the signal processing unit. It provides the advantage of mobility and long term EEG monitoring by using braincap technology. The signal processing unit gives compelling calculations to provide real time decision for drowsiness detection. In addition to drowsiness detection, the enhancement of lifetime of the network used in BCI is an important factor. To achieve this desired property, the proposed EEC-PSO technique has been found suitable.



# Chapter 7

## Conclusions and Future Scope of Work

The conclusive comments taking into account the research work carried out in this thesis are incorporated in this chapter alongside the degree of future work.

Huge scale organization of ease sensor nodes in uncontrolled, cruel or unfriendly situations is the natural property of WSNs. In wireless sensor networks, base stations are associated with wired backbone, which support real time processing of the received data. The ideal location of the base station can be maintained such that, the transmission energy expenditure is minimized, and the lifetime of the sensor network is maximized. This thesis has given the cluster longevity by extending the cluster lifetime with the utilization of heterogeneous sensor nodes, distributed clustering and energy efficient clustering.

In this thesis, Chapter 2 depicts the protocols proposed for the efficient design of clustering in WSN. The existing clustering schemes are thoroughly examined in this chapter. The correlation between the existing algorithms highlights the flaws and strengths associated with. Analysis of results has given a direction to move with proposing new protocols for clustering in WSN.

As a consequence of the distributed control for the cluster head selection, there are little time latency and correspondence overhead issues exists for designing clustering protocols in WSN. Moreover, utilizing the multi-hop routing for data transmission from cluster-heads to the base station needs some more time than direct communication. The clustering algorithm proposed in Chapter 3 aims at distributing workload among cluster-heads. This can maintain a strategic distance from the circumstance that some cluster-heads may pass on earlier than others because of the heavy load.

In Chapter 4, an energy efficient clustering protocol has been proposed. Energy efficiency, energy appropriation, and network lifetime are characterized as the performance measurements to contrast the proposed protocol with three existing clustering protocols. Simulation results demonstrate that the proposed protocol outperformed existing protocols regarding the vast majority of the performance metrics. Besides, these outcomes verified the theoretic analysis of the protocol in light of the time complexity and space complexity. Keeping in mind the end goal to reduce the energy consumption for data transmission from cluster-heads to the base station, energy efficient clustering algorithm is developed. Significant energy dissipation of data transmission can be diminished by utilizing this clustering algorithm.

In Chapter 5, a PSO based energy efficient clustering protocol has been proposed. For  $N$  sensor nodes, there are  $2^N - 1$  distinctive combination of solutions, where in each arrangement, a sensor node is either chosen as CH or non-CH. This has been ended up being a Non-deterministic Polynomial (NP)-hard optimization problem. Solutions for NP-hard problems include searches through huge spaces of possible arrangements. Swarm intelligence methodologies have been applied effectively to a variety of NPhard problems.

A wireless BCI system with real time processing capacity is proposed in Chapter 6. It comprises of a signal acquisition unit and a signal processing

unit. Signal acquisition unit first acquired the EEG signal and afterward transmitted from a wireless data transmitter to the wireless data receiver. Wirelessly transmitted EEG signals are processed by the signal processing unit, to take the decision of triggering the warning device.

The general conclusions that can be drawn from the work presented in this thesis is that the discoveries will be helpful for the researchers, practitioners, and the software professionals in light of the accompanying issues being addressed:

1. The advantage of using distributed clustering over centralized clustering.
2. It controls the amount of energy spent in data transmission to make the algorithm energy efficient.
3. An application of WSN can be observed in brain computer interface.

## **7.1 Future scope of work**

Nobody can unwrap the future. The future is a state in view of the arrangement of occasions that have occurred since the beginning state. Over the long haul, the effort put in are of concern. Activated by this perspective, all the work reported in this thesis work will lead to an extension that will prompt augmentation that will improve their effect in the particular area of work.

The research discoveries made out of this thesis has opened a few auxiliary research directions, which can be further explored. The proposed protocols that generally manage the cluster formation, cluster maintenance, and energy consumption can be reached out to some other areas of clustering like load balancing among the cluster-head, fault tolerant clustering. A further study will be useful to discover the exact mobility of the node and its resulting investigation. An alternate direction is to optimize the value of the maximum

transmission range for which the cluster maintenance can be decreased without compromising with the network lifetime. The communication overhead in the protocol ought to be diminished for the applications that oblige quick response and minimal overhead. A more elevated amount of data encryption with low computation may be used as a part of the future, to secure further the data transmission process. In the event of brain computer interface, we are only controlling the data transmission process by using clustering methodology to enhance the network lifetime. Whereas, the load balancing and security features can be added to the BCI system to make the approach more efficient and reliable.

# Dissemination

## Journals

1. **Asis Kumar Tripathy**, and Suchismita Chinara, “Comparison of Residual Energy-Based Clustering Algorithms for Wireless Sensor Network”, *ISRN Sensor Networks*, Hindawi, Vol. 2012, Article ID 375026, Pages. 1-10.
2. **Asis Kumar Tripathy**, and Suchismita Chinara, “Distributed Dynamic Clustering Protocol for Wireless Sensor Network”, *Int. Journal of Computer Applications in Technology*, Inderscience, Vol. 51, No. 2, Pages. 112-119, 2015
3. **Asis Kumar Tripathy**, Suchismita Chinara, and Mahasweta Sarkar, “An Application of Wireless Brain-Computer Interface for Drowsiness Detection”, *Biocybernetics and Biomedical Engineering*, Elsevier, Vol. 36, Issue. 1, Pages. 276-284. (I.F. 0.6).

## Book Chapter

1. **Asis Kumar Tripathy**, and Suchismita Chinara, “Evolution of Virtual Clustering in Wireless Sensor Networks”, in *Wireless Sensor Networks: From Theory to Applications*, CRC Press, Taylor & Francis Group, USA, August 2013

## Conferences

1. **Asis Kumar Tripathy**, and Suchismita Chinara, “Staggered Clustering Protocol: SCP an Efficient Clustering Approach for Wireless Sensor Network”, in *Proceedings of WICT 2012: IEEE 2<sup>nd</sup> World Congress on Information and Communication Technology*, pp. 937-941, 30<sup>th</sup> Oct-2<sup>nd</sup> November 2012, Trivandrum, India.
2. **Asis Kumar Tripathy**, and Suchismita Chinara, “Authenticated Data Transmission Technique for Clustered Wireless Sensor Network”, in *Proceedings of ICIS 2014: 9<sup>th</sup> IEEE International Conference on Industrial and Information Systems*, pp. , 15<sup>th</sup>-17<sup>th</sup> December 2014, Gwalior, India.

## Communicated

1. **Asis Kumar Tripathy**, and Suchismita Chinara, “Energy Efficient Clustering Protocol for Wireless Sensor Networks using PSO”, *Computer Networks*, Elsevier, Communicated.
2. **Asis Kumar Tripathy**, and Suchismita Chinara, “Energy Efficient Data Collection Algorithm for Wireless Brain-Computer Interface”, *Wireless Personal Communications*, Springer, Communicated.

# References

- [1] A. A. Abbasi and M. Younis, “A survey on clustering algorithms for wireless sensor networks,” *Computer communications*, vol. 30, no. 14, pp. 2826–2841, 2007.
- [2] O. Boyinbode, H. Le, and M. Takizawa, “A survey on clustering algorithms for wireless sensor networks,” *International Journal of Space-Based and Situated Computing*, vol. 1, no. 2, pp. 130–136, 2011.
- [3] K. Sohraby, D. Minoli, and T. Znati, *Wireless sensor networks: technology, protocols, and applications*. John Wiley & Sons, 2007.
- [4] S. Ci, M. Guizani, and H. Sharif, “Adaptive clustering in wireless sensor networks by mining sensor energy data,” *Computer Communications*, vol. 30, no. 14, pp. 2968–2975, 2007.
- [5] Y. Ozturk and V. Nagarnaik, “A scalable distributed dynamic address allocation protocol for ad-hoc networks,” *Wireless Networks*, vol. 17, no. 2, pp. 357–370, 2011.
- [6] R. Rout and S. Ghosh, “Enhancement of lifetime using duty cycle and network coding in wireless sensor networks,” *IEEE Transactions on Wireless Communications*, vol. 12, no. 2, pp. 656–667, 2013.
- [7] A. M. Mehta, “Mobility in wireless sensor networks,” Ph.D. dissertation, EECS Department, University of California, Berkeley, Dec 2012.

- 
- [8] S. Halder and S. DasBit, “Enhancement of wireless sensor network lifetime by deploying heterogeneous nodes,” *Journal of Network and Computer Applications*, vol. 38, pp. 106–124, 2014.
- [9] X. J. Li and P. H. Chong, “Performance analysis of multihop cellular network with fixed channel assignment,” *Wireless Networks*, vol. 16, no. 2, pp. 511–526, 2010.
- [10] K. Chebrolu and A. Dhekne, “Esense: Energy Sensing-Based Cross-Technology Communication,” *IEEE Transactions on Mobile Computing*, vol. 12, no. 11, pp. 2303–2316, 2013.
- [11] N. Pletcher and J. M. Rabaey, “Ultra-low power wake-up receivers for wireless sensor networks,” Ph.D. dissertation, EECS Department, University of California, Berkeley, May 2008.
- [12] K. S. Prabh, “Real-time wireless sensor networks,” Ph.D. dissertation, University OF Virginia, 2007.
- [13] R. Fonseca, O. Gnawali, K. Jamieson, S. Kim, P. Levis, and A. Woo, “The collection tree protocol (ctp),” *TinyOS TEP*, vol. 123, pp. 2–3, 2006.
- [14] I. Sim, K. Choi, K. Kwon, and J. Lee, “Energy efficient cluster header selection algorithm in wsn,” in *International Conference on Complex, Intelligent and Software Intensive Systems, 2009. CISIS’09.*, 2009, pp. 584–587.
- [15] H. Wang, N. Agoulmine, M. Ma, and Y. Jin, “Network lifetime optimization in wireless sensor networks,” *Selected Areas in Communications, IEEE Journal on*, vol. 28, no. 7, pp. 1127–1137, 2010.
- [16] S. Yi, J. Heo, Y. Cho, and J. Hong, “PEACH: Power-efficient and adaptive clustering hierarchy protocol for wireless sensor networks,” *Computer communications*, vol. 30, no. 14, pp. 2842–2852, 2007.



- [17] M. Chatterjee, S. K. Das, and D. Turgut, “WCA: A weighted clustering algorithm for mobile ad hoc networks,” *Cluster Computing*, vol. 5, no. 2, pp. 193–204, 2002.
- [18] W. Heinzelman, A. Chandrakasan, and H. Balakrishnan, “An application-specific protocol architecture for wireless microsensor networks,” *IEEE Transactions on Wireless Communications*, vol. 1, no. 4, pp. 660–670, 2002.
- [19] X. Du, Y. Xiao, and F. Dai, “Increasing network lifetime by balancing node energy consumption in heterogeneous sensor networks,” *Wireless Communications and Mobile Computing*, vol. 8, no. 1, pp. 125–136, 2008.
- [20] M. Younis, M. Youssef, and K. Arisha, “Energy-aware management for cluster-based sensor networks,” *Computer Networks*, vol. 43, no. 5, pp. 649–668, 2003.
- [21] D. J. Baker, A. Ephremides, and J. Flynn, “The design and simulation of a mobile radio network with distributed control,” *IEEE Journal on Selected Areas in Communications*, vol. 2, no. 1, pp. 226–237, 1984.
- [22] N. Shigei, H. Miyajima, H. Morishita, and M. Maeda, “Centralized and distributed clustering methods for energy efficient wireless sensor networks,” in *Proceedings of the International MultiConference of Engineers and Computer Scientists*, vol. 1, 2009, pp. 18–20.
- [23] A. B. Bomgni and J. F. Myoupo, “An energy-efficient clique-based geocast algorithm for dense sensor networks,” *Communications and Network*, vol. 2010, pp. 125–133, 2010.
- [24] N. Vlahic and D. Xia, “Wireless sensor networks: to cluster or not to cluster?” in *Proceedings of the 2006 International Symposium on on World of Wireless, Mobile and Multimedia Networks*. IEEE Computer Society, 2006, pp. 258–268.
- [25] C. Schurgers and M. B. Srivastava, “Energy efficient routing in wireless sensor networks,” in *IEEE Military Communications Conference, (MILCOM)*, vol. 1, 2001, pp. 357–361.

- [26] S. R. B. Prabhu and S. Sophia, "A survey of adaptive distributed clustering algorithms for wireless sensor networks," *International Journal of Computer Science and Engineering Survey*, vol. 2, no. 4, pp. 165–176, 2011.
- [27] Z. Liu, Q. Zheng, L. Xue, and X. Guan, "A distributed energy-efficient clustering algorithm with improved coverage in wireless sensor networks," *Future Generation Computer Systems*, vol. 28, no. 5, pp. 780–790, 2012.
- [28] M. Veyseh, "Energy efficient clustering and routing protocols for wireless sensor networks," Ph.D. dissertation, San Jose Sate University, 2005.
- [29] D. Mandala, X. Du, F. Dai, and C. You, "Load balance and energy efficient data gathering in wireless sensor networks," *Wireless Communications and Mobile Computing*, vol. 8, no. 5, pp. 645–659, 2008.
- [30] H. Lu, J. Li, and M. Guizani, "Secure and efficient data transmission for cluster-based wireless sensor networks," *IEEE Transactions on Parallel and Distributed Systems*, vol. 25, no. 3, pp. 750–761, 2014.
- [31] Y. He, Y. Zhang, Y. Ji, and X. S. Shen, "A new energy efficient approach by separating data collection and data report in wireless sensor networks," in *Proceedings of the 2006 international conference on Wireless communications and mobile computing*, 2006, pp. 1165–1170.
- [32] N. M. Latiff, C. C. Tsimenidis, and B. S. Sharif, "Energy-aware clustering for wireless sensor networks using particle swarm optimization," in *IEEE 18th International Symposium on Personal, Indoor and Mobile Radio Communications*, 2007, pp. 1–5.
- [33] J. Kennedy, "Particle swarm optimization," in *Encyclopedia of Machine Learning*. Springer, 2010, pp. 760–766.
- [34] S. Lee, Y. Shin, S. Woo, K. Kim, and H. Lee, *Review of Wireless Brain-Computer Interface Systems*. InTech, 2013.

- [35] F. Lotte, M. Congedo, A. Lecuyer, F. Lamarche, and B. Arnaldi, "A review of classification algorithms for EEG bases brain computer interface," *Human Factors*, vol. 4, no. R1-R13, 2007.
- [36] C. T. Lin, F. C. Lin, S. A. Chen, S. W. Lu, T. C. Chen, and L. W. Ko, "EEG-based brain-computer interface for smart living environmental auto-adjustment," *Journal of Medical and Biological Engineering*, vol. 30, no. 4, pp. 237–245, 2010.
- [37] Y. T. Wang, Y. j. Wang, and T. P. Jung, "A cell-phone-based brain-computer interface for communication in daily life," *Journal of neural engineering*, vol. 8, no. 2, pp. 233–240, 2011.
- [38] C. T. Lin, Y. C. Chen, T. Y. Huang, T. T. Chiu, L. W. Ko, S. F. Liang, H. Y. Hsieh, S. H. Hsu, and J. R. Duann, "Development of wireless brain computer interface with embedded multitask scheduling and its application on real-time driver's drowsiness detection and warning," *IEEE Transactions on Biomedical Engineering*, vol. 55, no. 5, pp. 1582–1591, 2008.
- [39] W. R. Heinzelman, A. Chandrakasan, and H. Balakrishnan, "Energy-efficient communication protocol for wireless microsensor networks," in *Proceedings of the 33rd Annual Hawaii International Conference on System Sciences, 2000*, 2000, pp. 1–10.
- [40] V. Katiyar, N. Chand, and S. Soni, "Clustering algorithms for heterogeneous wireless sensor network: A survey," *International Journal of applied Engineering research*, vol. 1, no. 2, pp. 273–274, 2010.
- [41] N. Dimokas, D. Katsaros, and Y. Manolopoulos, "Energy-efficient distributed clustering in wireless sensor networks," *Journal of parallel and Distributed Computing*, vol. 70, no. 4, pp. 371–383, 2010.
- [42] K. Dasgupta, K. Kalpakis, and P. Namjoshi, "An efficient clustering-based heuristic for data gathering and aggregation in sensor networks," in *IEEE*

- 
- Wireless Communications and Networking, (WCNC'03)*, vol. 3, 2003, pp. 1948–1953.
- [43] X. Min, S. Wei-Ren, J. Chang-Jiang, and Z. Ying, “Energy efficient clustering algorithm for maximizing lifetime of wireless sensor networks,” *AEU-International Journal of Electronics and Communications*, vol. 64, no. 4, pp. 289–298, 2010.
- [44] G. Wittenburg, K. Terfloth, F. L. Villafuerte, T. Naumowicz, H. Ritter, and J. Schiller, “Fence monitoring: experimental evaluation of a use case for wireless sensor networks,” in *Proceedings of the 4th European conference on Wireless sensor networks*, ser. EWSN'07, 2007, pp. 163–178.
- [45] X. Zhu, L. Shen, and T. Yum, “Hausdorff clustering and minimum energy routing for wireless sensor networks,” in *IEEE 18th International Symposium on Personal, Indoor and Mobile Radio Communications, 2007.*, ser. PIMRC 2007, 2007, pp. 1–7.
- [46] S. Chinara and S. K. Rath, “A survey on one-hop clustering algorithms in mobile ad hoc networks,” *Journal of Network and Systems Management*, vol. 17, no. 1-2, pp. 183–207, 2009.
- [47] B. Elbhiri, R. Saadane, and D. Aboutajdine, “Stochastic and equitable distributed energy efficient clustering (SEDEEC) for heterogeneous wireless sensor networks,” *Int. J. Ad Hoc Ubiquitous Comput.*, vol. 7, no. 1, pp. 4–11, 2011.
- [48] Y. T. Hou, Y. Shi, H. D. Sherali, and S. F. Midkiff, “On energy provisioning and relay node placement for wireless sensor networks,” *IEEE Transactions on Wireless Communications*, vol. 4, no. 5, pp. 2579–2590, 2005.
- [49] R. Rajagopalan and P. K. Varshney, “Data aggregation techniques in sensor networks: A survey,” *IEEE Comm. Surveys and Tutorials*, vol. 8, no. 4, pp. 48–63, 2006.

- [50] C. Chong and S. P. Kumar, “Sensor networks: evolution, opportunities, and challenges,” *Proceedings of the IEEE*, vol. 91, no. 8, pp. 1247–1256, 2003.
- [51] D. J. Baker and A. Ephremides, “The architectural organization of a mobile radio network via a distributed algorithm,” *IEEE Transactions on Communications*, vol. 29, no. 11, pp. 1694–1701, 1981.
- [52] A. Ephremides, J. E. Wieselthier, and D. J. Baker, “A design concept for reliable mobile radio networks with frequency hopping signaling,” *Proceedings of the IEEE*, vol. 75, no. 1, pp. 56–73, 1987.
- [53] C. R. Lin and M. Gerla, “Adaptive clustering for mobile wireless networks,” *IEEE Journal on Selected Areas in Communications*, vol. 15, no. 7, pp. 1265–1275, 1997.
- [54] K. Xu and M. Gerla, “A heterogeneous routing protocol based on a new stable clustering scheme,” in *Proceedings of Military communications conference (MILCOM’02)*, vol. 2, 2002, pp. 838–843.
- [55] R. Nagpal and D. Coore, “An algorithm for group formation in an amorphous computer,” in *Proceedings of 10th International Conference on Parallel and Distributed Computing Systems (PDCS98)*, 1998.
- [56] O. Younis, M. Krunz, and S. Ramasubramanian, “Node clustering in wireless sensor networks: Recent developments and deployment challenges,” *IEEE Network Magazine*, vol. 20, no. 3, pp. 20–25, 2006.
- [57] T. Kaur and J. Baek, “A strategic deployment and cluster-header selection for wireless sensor networks,” *IEEE Transactions on Consumer electronics*, vol. 55, no. 4, pp. 1890–1897, 2009.
- [58] A. Boukerche, H. Oliveira, E. Nakamura, and A. Loureiro, “Localization systems for wireless sensor networks,” *IEEE Wireless Commun. Mag*, vol. 14, no. 6, pp. 6–12, 2007.

- 
- [59] H. Chan and A. Perrig, “ACE: An emergent algorithm for highly uniform cluster formation,” in *Wireless Sensor Networks*, ser. Lecture Notes in Computer Science. Springer, 2004, vol. 2920, pp. 154–171.
- [60] M. C. M. Thein and T. Thein, “An energy efficient cluster-head selection for wireless sensor networks,” in *Proceedings of International Conference on Intelligent Systems, Modeling and Simulation*, 2010, pp. 287–291.
- [61] O. Younis and S. Fahmy, “HEED: A hybrid, energy-efficient, distributed clustering approach for ad hoc sensor networks,” *IEEE Transactions on Mobile Computing*, vol. 3, no. 4, pp. 366–379, 2004.
- [62] P. Ding, J. Holliday, and A. Celik, “Distributed Energy-Efficient Hierarchical Clustering for Wireless Sensor Networks,” in *Distributed Computing in Sensor Systems*, ser. Lecture Notes in Computer Science. Springer, 2005, vol. 3560, pp. 322–339.
- [63] P. Neamatollahi, H. Taheri, M. Naghibzadeh, and M. Yaghmaee, “A hybrid clustering approach for prolonging lifetime in wireless sensor networks,” in *International Symposium on Computer Networks and Distributed Systems (CNDS)*, 2011, pp. 170–174.
- [64] X. Wang and G. Zhang, “Decp: A distributed election clustering protocol for heterogeneous wireless sensor networks,” in *Proceedings of the 7th international conference on Computational Science, Part III*, ser. ICCS '07, 2007, pp. 105–108.
- [65] B. Gong, L. Li, S. Wang, and X. Zhou, “Multihop routing protocol with unequal clustering for wireless sensor networks,” in *ISECS International Colloquium on Computing, Communication, Control, and Management, 2008. CCCM '08.*, vol. 2, 2008, pp. 552–556.
- [66] D. Kumar, T. C. Aseri, and R. B. Patel, “EEHC: Energy efficient heterogeneous clustered scheme for wireless sensor networks,” *Computer Communications*, vol. 32, no. 4, pp. 662–667, 2009.

- [67] H. Zhou, Y. Wu, Y. Hu, and G. Xie, "A novel stable selection and reliable transmission protocol for clustered heterogeneous wireless sensor networks," *Comput. Commun.*, vol. 33, no. 15, pp. 1843–1849, 2010.
- [68] C. Li, M. Ye, G. Chen, and J. Wu, "An energy efficient unequal clustering mechanism for wireless sensor networks," in *Proceedings of IEEE International Conference on Mobile Adhoc and Sensor Systems*, ser. MASS'05, 2005, pp. 604–611.
- [69] L. Qing, Q. Zhu, and M. Wang, "Design of a distributed energy-efficient clustering algorithm for heterogeneous wireless sensor networks," *Comput. Commun.*, vol. 29, no. 12, 2006.
- [70] M. Ye, C. Li, G. Chen, and J. Wu, "EECS: An energy efficient clustering scheme in wireless sensor networks," in *Proceedings of the IEEE Conference on International conference on Performance Computing and Communications*, 2005, pp. 535–540.
- [71] M. Demirbas, A. Arora, and V. Mittal, "FLOC: A fast local clustering service for wireless sensor networks," in *Workshop on Dependability Issues in Wireless Ad Hoc Networks and Sensor Networks*, ser. DIWANS/DSN 2004, 2004, pp. 1–6.
- [72] S. Banerjee and S. Khuller, "A clustering scheme for hierarchical control in multi-hop wireless networks," in *Proceedings of the 20th Annual Joint Conference of the IEEE Computer and Communications Societies*, ser. INFOCOM 2001, vol. 2, 2001, pp. 1028–1037.
- [73] H. Zhang and A. Arora, "GS3: Scalable self-configuration and self-healing in wireless networks," *Computer Networks*, vol. 43, no. 4, pp. 459–480, 2003.
- [74] A. Youssef, M. Younis, M. Youssef, and A. Agrawala, "Distributed formation of overlapping multi-hop clusters in wireless sensor networks," in *Proceedings of the 49th Annual IEEE Global Communication Conference*, ser. Globecom06, 2006, pp. 1–6.

- 
- [75] K. Wang, S. A. Ayyash, T. D. C. Little, and P. Basu, "Attribute-based clustering for information dissemination in wireless sensor networks," in *Proceeding of 2nd Annual IEEE Communications Society Conference on Sensor and Ad Hoc Communications and Networks*, ser. SECON05, 2005, pp. 498–509.
- [76] S. K. Singh, M. P. Singh, and D. K. Singh, "Energy-efficient homogeneous clustering algorithm for wireless sensor network," *International Journal of Wireless & Mobile Networks*, vol. 2, no. 3, pp. 49–61, 2010.
- [77] A. Norouzi, F. S. Babamir, and A. H. Zaim, "A new clustering protocol for wireless sensor networks using genetic algorithm approach," *Wireless Sensor Network*, vol. 3, no. 11, pp. 362–370, 2011.
- [78] C. Lin, C. Chang, B. Lin, S. Hung, C. Chao, and I. Wang, "A real-time wireless brain–computer interface system for drowsiness detection," *IEEE Transactions on Biomedical Circuits and Systems*, vol. 4, no. 4, pp. 214–222, 2010.
- [79] S. Filipe, G. Charvet, M. Foerster, J. Porcherot, J. Beche, S. Bonnet, P. Audebert, G. Regis, B. Zongo, S. Robinet, C. Condemine, C. Mestais, and R. Guillemaud, "A wireless multichannel EEG recording platform," in *Annual IEEE International Conference of the Engineering in Medicine and Biology Society*, ser. EMBC'11, 2011, pp. 6319–6322.
- [80] T. Hong and H. Qin, "Drivers drowsiness detection in embedded system," in *IEEE International Conference on Vehicular Electronics and Safety*, ser. ICVES'07, 2007, pp. 1–5.
- [81] J. S. Lin, K. C. Chen, and W. C. Yang, "EEG and eye-blinking signals through a brain-computer interface based control for electric wheelchairs with wireless scheme," in *4th International Conference on New Trends in Information Science and Service Science*, ser. NISS'10, 2010, pp. 731–734.
- [82] Q. Ji, Z. Zhu, and P. Lan, "Real-time nonintrusive monitoring and prediction



- of driver fatigue,” *IEEE Transactions on Vehicular Technology*, vol. 53, no. 4, pp. 1052–1068, 2004.
- [83] M. J. Flores, J. M. Armingol, and A. Escalera, “Real-time drowsiness detection system for an intelligent vehicle,” in *IEEE Intelligent Vehicles Symposium*, 2008, pp. 637–642.
- [84] A. Eskandarian and A. Mortazavi, “Evaluation of a smart algorithm for commercial vehicle driver drowsiness detection,” in *IEEE Intelligent Vehicles Symposium*, 2007, pp. 553–559.
- [85] I. F. Akyildiz, W. Su, Y. S. subramaniam, and E. Cayirci, “Wireless sensor networks: a survey,” *Computer Networks*, vol. 38, no. 4, pp. 393–422, 2002.
- [86] N. M. A. Latiff, C. C. Tsimenidis, B. S. Sharif, and C. Ladha, “Dynamic clustering using binary multi-objective particle swarm optimization for wireless sensor networks,” in *19th IEEE International Symposium on Personal, Indoor and Mobile Radio Communications*, 2008, pp. 1–5.
- [87] D. Sun, Y. Liu, A. Wang, and B. Ge, “Research on Service-Oriented Lifetime and Network Density in WSN,” in *The 9th International Conference for Young Computer Scientists*, ser. ICYCS’08, 2008, pp. 439–444.
- [88] G. Xin, W. HuaYang, and B. DeGang, “EEHCA: Energy efficient hierarchical clustering algorithm for wireless sensor networks,” *Information Technology*, vol. 7, no. 2, pp. 245–252, 2008.
- [89] C. Duan and H. Fan, “A distributed energy balance clustering protocol for heterogeneous wireless sensor networks,” in *International Conference on Wireless Communications, Networking and Mobile Computing*, ser. WiCom’07, 2007, pp. 2469–2473.
- [90] D. Kumar and R. B. Patel, “Multi-hop data communication algorithm for clustered wireless sensor networks,” *International Journal of Distributed Sensor Networks*, pp. 1–10, 2011.

- 
- [91] C. Stefano, N. Chilamkurti, and S. Zeadally, “A novel centralized clustering algorithm for energy efficient wireless sensor networks,” *International Journal of Autonomous and Adaptive Communications Systems*, vol. 1, no. 2, pp. 242–261, 2008.
- [92] N. Katiyar, V. Chand and S. Soni, “A survey on clustering algorithms for heterogeneous wireless sensor networks,” *International Journal of Advanced Networking and Applications*, vol. 2, no. 4, pp. 745–754, 2011.
- [93] S. Lindsey and C. Raghavendra, “PEGASIS: Power-efficient gathering in sensor information systems,” in *IEEE Aerospace Conference Proceedings*, vol. 3, 2002, pp. 1125–1130.
- [94] S. Soro and W. B. Heinzelman, “Cluster head election techniques for coverage preservation in wireless sensor networks,” *Ad Hoc Networks*, vol. 7, no. 5, pp. 955–972, 2009.
- [95] G. Anastasi, M. Conti, M. D. Francesco, and A. Passarella, “Energy conservation in wireless sensor networks: a survey,” *Ad Hoc Networks*, vol. 7, no. 3, pp. 537–568, 2009.
- [96] M. J. Handy, M. Haase, and D. Timmermann, “Low energy adaptive clustering hierarchy with deterministic cluster-head selection,” in *4th International Workshop on Mobile and Wireless Communications Network*, 2002, pp. 368–372.
- [97] V. Mhatre and C. Rosenberg, “Design guidelines for wireless sensor networks: communication, clustering and aggregation,” *Ad Hoc Networks*, vol. 2, no. 1, pp. 45–63, 2004.
- [98] L. Lu, “Design study of energy-efficient routing protocol for wireless sensor networks.” Ph.D. dissertation, The University of Adelaide, Australia, 2009.
- [99] K. Srinivasan, P. Dutta, A. Tavakoli, and P. Levis, “An empirical study of low-power wireless,” *ACM Transactions on Sensor Networks (TOSN)*, vol. 6, no. 2, pp. 16–20, 2010.

- 
- [100] P. K. Agarwal and C. M. Procopiuc, “Exact and approximation algorithms for clustering,” *Algorithmica*, vol. 33, no. 2, pp. 201–226, 2002.
- [101] L. Arboleda and N. Nasser, “Comparison of clustering algorithms and protocols for wireless sensor networks,” in *Canadian Conference on Electrical and Computer Engineering, (CCECE’06)*, 2006, pp. 1787–1792.
- [102] N. Baccour, A. Koubaa, L. Mottola, M. A. Zuniga, H. Youssef, C. A. Boano, and M. Alves, “Radio link quality estimation in wireless sensor networks: a survey,” *ACM Transactions on Sensor Networks (TOSN)*, vol. 8, no. 4, p. 34, 2012.
- [103] S. K. and K. Levis, “Rssi is under appreciated,” in *Proceedings of the Third Workshop on Embedded Networked Sensors, (EmNets)*, 2006, pp. 239–242.
- [104] J. Qiang, Z. Zhiwei, and P. Lan, “Real-time nonintrusive monitoring and prediction of driver fatigue,” *IEEE Transactions on Vehicular Technology*, vol. 53, no. 4, pp. 1052–1068, 2004.
- [105] “NHTSA National Highway Traffic Safety Administration. Washington, D.C. [online]. available: <http://www.nhtsa.dot.gov/>,” 2014.
- [106] “Sleep facts and stats, National Sleep Foundation. Washington, D.C. [online]. available: <http://www.sleepfoundation.org/>,” 2014.
- [107] K. V. Orden, W. Limbert, S. Makeig, and T. P. Jung, “Eye activity correlates of workload during a visual spatial memory task,” *Human Factors*, vol. 43, no. 1, pp. 111–121, 2001.
- [108] C. Lin, C. Chang, B. Lin, S. Hung, C. Chao, and I. Wang, “A real-time wireless brain–computer interface system for drowsiness detection,” *Biomedical Circuits and Systems, IEEE Transactions on*, vol. 4, no. 4, pp. 214–222, 2010.

- [109] S. Bashyal and G. K. Venayagamoorthy, “Collaborative routing algorithm for wireless sensor network longevity,” in *IEEE 3rd International Conference on Intelligent Sensors, Sensor Networks and Information*, 2007, pp. 515–520.
- [110] “Electroencephalography (EEG),” <http://en.wikipedia.org/wiki/Electroencephalography>, accessed: 2014-11-30.
- [111] K. V. Mardia, “Mardia’s test of multinormality in encyclopedia of statistical sciences,” pp. 217–221, 1985.
- [112] L. Liao, C. Chen, I. Wang, S. Chen, S. Li, B. Chen, J. Chang, and C. Lin, “Gaming control using a wearable and wireless eeg-based brain-computer interface device with novel dry foam-based sensors,” *Journal of neuroengineering and rehabilitation*, vol. 9, no. 1, p. 5, 2012.
- [113] U. Hoffmann, J. Vesin, T. Ebrahimi, and K. Diserens, “An efficient p300-based brain-computer interface for disabled subjects,” *Journal of Neuroscience methods*, vol. 167, no. 1, pp. 115–125, 2008.