

**AMBIENT AIR QUALITY MODELLING USING AERMOD  
AND PARTICULATE MATTER CHARACTERIZATION  
IN OPENCAST MINES**

*A THESIS SUBMITTED IN PARTIAL FULFILLMENT OF  
THE REQUIREMENTS FOR THE DEGREE*

*Of*

**MASTER OF TECHNOLOGY  
IN  
MINING ENGINEERING**

By

**KAUSHAL KISHORE**  
213MN1494



**DEPARTMENT OF MINING ENGINEERING  
NATIONAL INSTITUTE OF TECHNOLOGY  
ROURKELA – 769 008  
2015**

**AMBIENT AIR QUALITY MODELLING USING AERMOD  
AND PARTICULATE MATTER CHARACTERIZATION  
IN OPENCAST MINES**

*A THESIS SUBMITTED IN PARTIAL FULFILLMENT OF  
THE REQUIREMENTS FOR THE DEGREE*

*Of*

**MASTER OF TECHNOLOGY  
IN  
MINING ENGINEERING**

By

**KAUSHAL KISHORE  
213MN1494**

UNDER THE GUIDANCE OF  
**PROF. H. B. SAHU**



**DEPARTMENT OF MINING ENGINEERING  
NATIONAL INSTITUTE OF TECHNOLOGY  
ROURKELA – 769 008**

**2015**



**NATIONAL INSTITUTE OF TECHNOLOGY  
ROURKELA**

---

**CERTIFICATE**

This is to certify that the thesis entitled “**Ambient Air Quality Modelling using Aermod and Particulate Matter Characterization in Opencast Mines**” submitted by **Shri Kaushal Kishore** for the final completion towards the award of Master of Technology degree in Mining Engineering at National Institute of Technology, Rourkela; is an authentic work carried out by them under my supervision and guidance.

To the best of my knowledge, the matter embodied in the thesis has not been submitted to any other University/Institute for the award of any Degree or Diploma.

Date:

**Prof. H. B. Sahu**  
Department of Mining Engineering  
National Institute of Technology  
Rourkela-769008

# DECLARATION

---

I certify that

- The work contained in the thesis is original and has been done by myself under the supervision of my supervisor.
- The work has not been submitted to any other Institute for any degree or diploma.
- The writing of this thesis is as per the prescribed guidelines of the Institute.
- I have taken utmost care to adhere by the norms and guidelines of the institute.
- The work of others wherever is used are cited in the reference section of the thesis.
- The referred sites for the work has been mentioned in the reference section.

Kaushal Kishore

## ACKNOWLEDGEMENT

---

I am highly obliged to my project guide Dr. Himanshu Bhushan Sahu, Associate Professor, Department of Mining Engineering; for his inspiring guidance, constructive criticisms, valuable suggestions and help throughout this project work. I am very much thankful to him for his painstaking effort in improving my understanding of this project.

I would like to express my sincere thanks to Er. Rajesh Kanungo, COO (Chief Operating Officer), Sun Consultancy and Services, Bhubaneswar for his help in understanding the finer points of air quality modeling and guidance in learning the AERMOD software.

I am thankful to Mr. N. Mallick, Regional Officer, SPCB Rourkela Regional office for his help in arranging the field visit for carrying out the study.

I would also like to extend my sincere thanks to faculty and staff members of Department of Mining Engineering, NIT Rourkela for their support and help.

I would also like to thank my friends and family for extending all sorts of support for the successful completion of the project.

**Date:**

**KAUSHAL KISHORE**

**Roll No.: 213MN1494**

Department of Mining Engineering

National Institute of Technology

Rourkela-769008

## ABSTRACT

---

Particulate Matter (dust) pollution is the most hazardous environmental issue associated with any opencast mining activity. Opencast extraction activities are major sources of air pollution in mining environment. The operations such as drilling, blasting, overburden/material handling and mineral processing generates large quantities of respirable particulate matter concentrations and are a potential source of air pollution. These airborne particulate matters are the main reason for the several severe health related issues such as Visibility disorder, Pneumoconiosis, neurological disorders etc. not only to the miners but to the people residing closer to mines. Therefore, the prediction of particulate matter concentration in and around the mine is essential to analyze the impact assessment of the mining activity over the surrounding environment. It is also necessary to identify the constituents of the particulate matter such that the severity of its impact can be analyzed at micro level.

Considering the above situation the present work focuses on the monitoring of the different sources of particulate matter generation in Iron and Manganese mines using the gravimetric dust samplers (Envirotech APM 460 NL). The prediction of the fugitive dust concentration at different locations of mine and nearby areas is carried out using AERMOD software. The particulate matter characterization (PM<sub>10</sub>) of some Iron and Manganese ore Mines such as Kalta, Essel, Oraghat, Tantra and Sanindpur mines from Sundargarh district of Odisha has been carried out using Atomic Absorption Spectrophotometer to find the presence of major mineral compositions in it. Patmunda project which is an opencast manganese mine situated in Sundergarh district of Odisha, was chosen for the modelling purpose, where ambient air monitoring was conducted from September 2014 to November 2014 at an averaging period of 1 hour, 24 hour and monthly basis to derive the particulate matter generation behaviour in and around the mines. Different modelling options with different source pathways have been evaluated viz: Line source modelling, Volume source modelling and open pit. It is found that the monitored and predicted particulate matter concentrations thus obtained were within the prescribed limits of NAAQS 2009. On the basis of these findings suitable mitigation and environmental plans can be devised for the sensitive areas.

# Table of Contents

<b>CERTIFICATE</b>	
<b>DECLARATION</b> .....	<b>i</b>
<b>ACKNOWLEDGEMENT</b> .....	<b>ii</b>
<b>ABSTRACT</b> .....	<b>iii</b>
<b>Table of Contents</b> .....	<b>iv</b>
<b>List of Figures</b> .....	<b>vii</b>
<b>List of Tables</b> .....	<b>viii</b>
<b>1. INTRODUCTION</b> .....	<b>1</b>
1.1 GENERAL .....	1
1.2 MOTIVATION .....	3
1.3 OBJECTIVES .....	3
1.4 ORGANIZATION OF THE THESIS.....	4
<b>2. LITERATURE REVIEW</b> .....	<b>5</b>
<b>3. ENVIRONMENTAL AND HEALTH IMPACTS</b> .....	<b>10</b>
3.1 PARTICULATE MATTER.....	10
3.1.1 Sources .....	11
3.2 ENVIRONMENTAL IMPACTS.....	12
3.3 HEALTH EFFECTS .....	13
3.3.1 Pneumoconiosis .....	14
3.3.2 Health hazards associated with Iron Ore dusts .....	15
3.3.3 Health hazards associated with Manganese ore dusts.....	15
<b>4. MODELLING AND CHARACTERIZATION</b> .....	<b>17</b>
4.1 MODELLING .....	17
4.1.1 Introduction.....	17
4.1.2 Models.....	17
4.1.3 Emission Rates.....	21
4.1.4 AERMOD View.....	23
4.2 MONITORING .....	29
4.2.1 PM <sub>10</sub> SAMPLING .....	31
4.2.2 PM <sub>2.5</sub> SAMPLING .....	33
4.2.3 Personal Dust Sampler.....	35

4.2.4 Dust Track II Aerosol Monitor 8532 .....	35
4.3 CHARACTERIZATION .....	36
<b>5. CASE STUDIES.....</b>	<b>40</b>
5.1 SPM and PM <sub>10</sub> MONITORING OF SOME IRON AND MANGANESE ORE MINES.....	40
5.1.1 BARSUAN – TALIDIH – KALTA Iron Mines (ML-130) of M/S SAIL.....	40
5.1.2 ORAGHAT Iron Mine of Rungta Sons Pvt. Ltd. ....	41
5.1.3 TANTRA Iron Ore Mines of M/S Korp Resources Pvt. Ltd.....	41
5.2 AIR QUALITY MODELLING OF PATMUNDA MANGANESE ORE MINE...	41
5.2.1 Methodology .....	43
5.2.2 Calculation of Haul road emission rate:.....	46
5.2.3 Calculation for open pit source: .....	47
5.3 PARTICULATE MATTER CHARACTERIZATION OF ESSEL, ORAGHAT, KALTA,TANTRA AND SANINDPUR IRON ORE MINES.....	51
<b>6. DISCUSSION AND CONCLUSION .....</b>	<b>52</b>
6.1 DISCUSSION .....	52
6.1.1 Practical application.....	54
6.2 CONCLUSION.....	55
<b>7. REFERENCES.....</b>	<b>59</b>



## List of Figures

---

Figure 3.1	Particulate generation from Blasting Operation .....	12
Figure 3.2	Dust particle size and penetration in respiratory tract .....	13
Figure 4.1	Gaussian plume .....	19
Figure 4.2	Data flow Diagram of AERMOD.....	24
Figure 4.3	AERMOD 8.2 Window with Line volume source modelling.....	28
Figure 4.4	Respirable Dust Sampler .....	31
Figure 4.5	A schematic sampler.....	32
Figure 4.6	PM <sub>2.5</sub> sampler .....	33
Figure 4.7	A Personal dust sampler .....	35
Figure 4.8	DustTrack II Aerosol Monitor 8532.....	36
Figure 4.9	Block Diagram of an Atomic Absorption Spectrophotometry.....	39
Figure 5.1	the location map of study area.....	42
Figure 5.2	Windrose diagram .....	45
Figure 5.3	Wind Class frequency distribution .....	45
Figure 5.4	Isopleths of Line Source Modelling .....	49
Figure 5.5	Isopleths of Volume Source modelling .....	49

## List of Tables

---

Table 4.1: Different mining activities and their Emission Factors .....	22
Table 4.2: National ambient air quality standard for Particulate Matter PM <sub>10</sub> .....	33
Table 4.3: National ambient air quality standard for Particulate Matter PM <sub>2.5</sub> .....	35
Table 5.1: AAQ monitoring result of Barsuan-Talidih-Kalta Iron Mines.....	40
Table 5.2: AAQ Monitoring result of Oraghat Iron Mine .....	41
Table 5.3: Monitoring result of Tantra Iron Ore mine.....	41
Table 5.4: Sample Met data used for the modelling purpose .....	44
Table 5.5: Input for Line source and Volume source modelling .....	46
Table 5.6: Fugitive dust concentrations at the sampling points.....	48
Table 5.7: Open pit modelling by varying pit size, orientation angle and release height.....	50
Table 5.8: Line Volume source modelling according to Wind direction .....	50
Table 5.9: Line Area Source modelling according to Wind directions .....	50
Table 5.10: The mineral constituents of particulate matter (PM <sub>10</sub> ) in µg/m <sup>3</sup> .....	51

# Chapter 1

## INTRODUCTION

### 1.1 GENERAL

It is the thrust towards the modernization that leads to exploitation of the natural resources. From the beginning of the civilization till date minerals have proved its need in almost every part of the society. Extraction of these minerals from the earth commonly termed as mining is thus essential for the world what we see today, whether its coal that we need for power generation or iron that serves the steel sector or limestone that bases the cement industry for the infrastructure development in all of the core sectors there is the necessity of minerals. With rapid industrialization and urbanization the need for the minerals increased rapidly so does the extraction.

There are two types of mining: surface mining or opencast mining which is the major source of mineral extraction and Underground mining. Though underground mining is costly and there is associated problems of transportation and ore extraction but it is quite suitable as far as environment is concerned. With the persisting situation we thus left with no other choice but open cast extraction.

Mostly mining activities produces particulate matter which is one of the major threat to environment once it becomes airborne. These airborne particulate matters leads to several severe health problems such as, visible impairment, Pneumoconiosis, allergic reactions etc. Dusts, as per the size of particulates are classified mainly as Total Suspended particulates (TSP), Particulate matter of size less than 10 microns ( $PM_{10}$ ) and Particulate matter of size less than 2.5 microns ( $PM_{2.5}$ ). These particulate matters are basically measured in microgram per cubic meters. The mining activities such as drilling, blasting, transportation, haul roads, overburden/mineral loading and unloading and losses from exposed overburden dumps, material handling plants, exposed pit faces and workshops i.e almost every mining activities generates huge amount of particulate matter. Therefore it is necessary to identify the emission sources and emission rates of different mining activities so that there impacts on the surrounding air quality can be known and depending on its severity proper preventive measures could be devised. It is equally important to know the constituents of these

particulate matters in order to find the correct pollutant composition and types of health issues it can create on miners and the people residing in the nearby areas.

Thus there are three basic requirements:

- Monitoring,
- Modelling and
- Characterization.

The monitoring is an essential part of the particulate matter impact assessment and so long term comprehensive monitoring is desired. Monitoring is done by sampling which includes a gravimetric sampler assembly and the glass fiber filter paper. The modelling is the prediction of the particulate matter concentrations in and around the mining areas based on the emission, meteorology, topography, deposition and other factors. Though the dispersion pattern and emission through the dispersion models are difficult to predict, since there are multiple number of sources of particulate matter generation, and the meteorology and topography varies widely, but by selecting the partial empirical equations for each activities at a time this could be possible. The characterization of the particulate matter is to find the constituent of it such as silica, mineral matter, and diesel exhausts etc. which determine its harmfulness towards human health.

Limited work has been done regarding the impact of Iron and Manganese ore mining in Indian context. Moreover many Iron and Manganese ore mines occurs in clusters such as Joda-Barbil area in Keonjhar district, Koira in Sundargarh district of Odisha etc. Though the environmental impact assessment for individual mines are carried out, but the cumulative impact for the number of mines occurring in clusters are rarely being considered. It has been noticed of late that the people residing in the area are suffering from a variety of lung diseases which may be due to the inhalation of particulate matter arising out of Iron and Manganese ore mining. In such areas no study has been carried out to validate and correlate impact of mining on health hazards.

In the present work, particulate matter monitoring of Patmunda open cast manganese mine is carried for dispersion modelling purpose while other open cast iron and manganese ore mines such as, Essel Iron ore Mines, Kalta Iron Ore Mines, Oraghat Iron Ore Mines, Tantra Iron Ore Mines and Sanindpur Iron and Bauxite Mines are taken for the particulate matter monitoring and characterization. Monitoring is performed by ENVIROTECH APM 460 NL

sampler for PM<sub>10</sub> and the modelling is done by AERMOD 8.2 for the prediction of the particulate matter concentration at the mining area. For the characterization of dust particulates first the segregation is done by acid digestion and then the solution is analyzed through Atomic Absorption Spectrophotometer for the detection of the presence of mineral matter in it.

## **1.2 MOTIVATION**

Ever since the evolution of mankind begun, we are thriving hard to exploit the natural resources without giving any concern towards the after effect of our actions such as degradation of air quality (the alteration of the state of air around us). Mining activities are potential source of air pollution as the involved practices generates huge amount of particulate matters. These particulate matters when become airborne causes severe health issues to the miners and the people of the surrounding areas. Different mining activities generates huge amount of fugitive dusts. When the workers are exposed to these for long duration they may get chronic bronchitis i.e. pneumoconiosis, cancer and other allergic disorders.

In lieu of the severity of the problem several attempts were made by the researchers to control the menace by identifying the emissions, predicting the concentrations of particulate matters and devising control measure to curb the problems. In the present work attempts are made to monitor the emissions and predicting the future of it by modelling, at the same time some more metal mines particulates are characterized in order to identify the percentage composition of the constituents present in them.

## **1.3 OBJECTIVES**

The particulate matter which proves to be the main source of air pollution in mining areas needed to be assessed. The present work has three main objectives: monitoring of particulate matter concentrations in open cast Iron and Manganese mines, particulate matter dispersion modelling and particulate matter characterization.

The monitoring of particulate matter through sampling gives the concentration in ambient air. The modelling determines the maximum ground level concentration of the generated particulate matter at any certain location. For the ambient air quality objective it is necessary to determine the concentration of the substance at the ground level. In order to analyze whether an emission meets the ambient air objective it is important to determine the ground-

level concentrations that may arise at various distances from the source which is the function of the dispersion model. The characterization gives the amount of constituents present in the particulates. The particulate matter from different iron and manganese ore mines are taken for the characterization purpose so that the micro analysis of dust particulates can be carried out. The current work has been planned with the following objectives:

- Assessment of the ambient air quality in the open cast Iron and Manganese ore mines in the Sundargarh district of Odisha.
- Collection of the respirable particulate matter monitoring data of some iron ore mines and from Patmunda Manganese ore mine for various operations and at various locations.
- Collection of micro-meteorological data for the duration of sampling like Collection of data from EIA reports and SPCB, Rourkela for the above areas.
- Modeling of particulate matter dispersion by AERMOD using the above data.
- To determine the constituent matter of particulate matters from different iron ore mines near the Sundargarh district of Odisha.

#### **1.4 ORGANIZATION OF THE THESIS**

The project “Ambient air quality modelling using AERMOD and particulate matter characterization in open cast metal mines” focusses on the ambient air quality assessment due to different mining activities. Literature review presents the earlier associated work in the field of particulate matter monitoring, modelling and characterization. The health impacts because of the generated particulate matters from metal mines are discussed in brief. Then the different applied methodologies included along with the site specific case studies have been mentioned. The plan of work can be summarized as listed below:

- Introduction to the work
- Literature Review
- Environmental and Health Impacts
- Modelling and Characterization
- Case Studies
- Discussion and Conclusion
- References

## Chapter 2

### LITERATURE REVIEW

Minerals are essential for human welfare. The extraction is associated with both opportunities and challenges. Primitive concerns regarding working conditions and the competitiveness of the mining sector have been associated by a growing number of other issues. Mining activities involves generation of huge amount of respirable particulate matters which contributes in polluting the environment.

Such concerns always had troubled the environmentalists and thus several means and ways had been tried out in analyzing and mitigating the problems. Particulate matter monitoring, modelling and characterization of mine dusts evolved by sheer dedication of the eminent researchers and experts. Some of the related works in such regard have been mentioned below:

**EPA (1995)** presented the dust dispersion modeling for surface mining operations using “The Industrial Source Complex model” ISC. A subroutine was included in this model for flat and complex terrain. This model successfully modelled dispersions from four types of emission sources: point source such as drilling point, volume source which includes blasting zones, area source such as haul road and open pit source. The model was based on Gaussian equation for point source emission of a typical stack which is given by the equation:

$$\chi = \frac{QKVD}{2\pi u_s \sigma_y \sigma_z} \exp \left[ -0.5 \left( \frac{y}{\sigma_y} \right)^2 \right] \text{----- (1)}$$

Where,

- $u_s$  : mean wind speed at the release height (m/sec)
- $\sigma_y$  : Standard deviation of lateral concentration distribution (m)
- $\sigma_x$  : Standard deviation of vertical concentration distribution (m)
- $\chi$  : Concentration at downwind distance x on an hourly basis ( $\mu\text{g}/\text{m}^3$ )
- y : Crosswind distance from source to receptor
- Q : Pollutant emission rate (g / sec)

- $K$  : Scaling coefficient to convert calculated concentrations to desired units
- $V$  : Vertical term
- $D$  : Decay term

**Pereira et al. (1997)** used the Gaussian dispersion equation to predict dust concentrations from the stockpiles of operating surface from a Portugal mine. The used equation was:

$$C = \frac{Q}{2\pi\sigma_y\sigma_x u} \exp\left[-0.5\left(\frac{y_r}{\sigma_y}\right)^2\right] \exp\left[-0.5\left(\frac{h_e - z_r}{\sigma_z}\right)^2\right] \dots\dots\dots (2)$$

Where,

- $C$  : Pollutant concentration at location receptor
- $Q$  : Emission rate
- $\sigma_y$  : Horizontal standard deviation.
- $\sigma_z$  : Vertical standard deviation.
- $\bar{u}$  : Average wind speed
- $h_e$  : Effective emission height.

The equation was used to create risk maps of air quality for locations surrounding the mine.

**Chaulya (1999)** did the study for a period of 1 year at the Lakhanpur area. The annual average concentrations of PM<sub>10</sub> and TSP found to be above the prescribed limits given by NAAQS. The linear regression analysis was used to predict the concentrations of one type of particulate matter by knowing the level of the other for the open cast coal mines. The sampling and analysis were done twice monthly for buffer zone (residential areas) and six times monthly for core zone/mining area (industrial areas) during the period Sep 1998 - Aug 1999.

It was suggested that effective control measures for the coal handling plant, excavation area & overburden dumps should be optimized to mitigate the emissions of respirable dusts. The concentrations of carbon monoxide (CO) and lead (Pb) were found below the detectable limits.

**Vernath et al. (2000)** conducted the laboratory method of productions of particulates and performed its detailed characterization in order to find the inhalable intracellular iron.



Anderson cascade impactor were used for generating particles whereas multi-jet pre-separator and rectangular slot virtual separator were used for fractioning purpose. The iron particles mobilization was done by physiologically relevant chelator which was not in correlation with the total iron. They found that the particle characteristics and iron speciation are important for the analysis of abnormality in human airway epithelial cells thus, particle sources and size fractions both should be given equal emphasis for the detail characterization.

**Ghose and Majee (2001)** observed that the emission of particulate matters is not only functional but it depends on the seasons too. The open cast coal production has higher contribution in total coal production in the country (about 70%) so this proved to be the better way of analyzing the air pollution resulting due to different mining activities. It was observed that the air pollutants coming from mines had seasonal fluctuations in its quantity and on the health. The control measure such as afforestation and use of chemicals on haul road along with sprinkler system were suggested by them so that pollution free environment could be achieved.

**Banerjee *et al.* (2001)** carried out the study on the twelve open cast mining activities in Belpahar open cast coal mines in Orissa. The Pasquill and Gifford formula was used to compute ground level emissions. It was found that the total emission rate of haul and transport roads contributes 2.3749g/s out of the total emissions of overall mining activities of 25.7117g/s. The emission of NO<sub>x</sub> and SO<sub>2</sub> were negligible. The result shows that the maximum contribution in air pollution was because of SPM, among all other mining activities. They concluded that SPM is the major problem associated with the open cast mining and so short term and long term biological measures were suggested for its control.

**Chakraborty *et al.* (2002)** developed empirical formulae with the objective to calculate emission rate of various opencast mining activities. For the purpose they selected seven coal and 3 iron ore mines based on the available resources, their locations and working methods. In the process they developed 12 Empirical formula for Suspended particulate matter generating from different mining activities such as drilling, haul road, exposed pits etc. For the verification and the universal applicability of the formula Rajpura opencast coal mines was chosen and it was found that the calculated value was 77.2% to 80.4% of the actual field value. They concluded that suspended particulate matter is the main constituent of emissions while NO<sub>x</sub> and SO<sub>2</sub> had negligible contribution to it. The result proved to be of great importance to the engineers and scientists related to the field of air quality monitoring.

**Anastasiadou and Gidarakos (2006)** evaluated the environmental quality of open air asbestos mine at Northern Greece over a long period of time by measuring and monitoring the concentration of asbestos fibres in the atmosphere. Sampling was performed according to the standard method for asbestos sampling— NIOSH Method 740 for phase contrast microscopy (PCM) and as per the EU guidelines for air sampling. The samples were taken from the fixed locations 1.5m above the ground level. Samples were first observed optically and were analyzed afterwards with XRD (X-ray diffraction) and Scanning electronic microscope (SEM), the suspected fibres were examined with an energy dispersive X-ray. They came out with the result that majority of the asbestos exposure is attributed to human activities such as excavations, the treatment of asbestos, the use of asbestos and the disposal of asbestos products into landfills.

**Trivedi and Chakraborty (2008)** studied the different sources of particulate matter generation due to coal mining activities and quantification of particulate matter emission and its dispersion for the Durgapur Opencast Coal Project of WCL. Particulate matter dispersion in horizontal as well as vertical direction was estimated by the procedure suggested by Pasquill and Gifford keeping in view the stability class of prevalent meteorological conditions. The particulate matter emission rates for different point, line and area sources were estimated considering the background particulate matter concentration. For the selected stations ambient air quality data was generated and air quality modeling was done using FDM (Fugitive Dust Model) at the source as well as at the selected receptors at different distances along downwind directions. They found that under normal meteorological conditions particulate matter generated due to mining activities does not contribute to ambient air quality significantly in surrounding areas beyond 500m.

**Sharma and Siddiqui (2010)** performed for the assessment and management of the air quality around Jayant open cast coal mining situated at Jayant in Sidhi district of Madhya Pradesh. The monitoring for TSP, NO<sub>x</sub> and SO<sub>2</sub> was done for 24 hrs. once every 15 days at each sites. They used HVS (High Volume Sampler) with glass fiber filter paper for the sampling purpose. The study revealed that the concentration of dust particulates exceeded the prescribed limit especially during the post and pre monsoon i.e. summer and winter. Implementation of regular cleaning of transportation roads, establishment of water and chemical binding agent sprinkler system and effective dust suppression mechanisms at the CHP were recommended.

**Roy *et al.* (2010)** attempted to quantify the particulate matter emission due to blasting operations. The other mining operations had the emission factors for the quantification purpose so they developed the emission factor for blasting by carrying out detailed field study of one of the largest Indian opencast coal mine for a period of one year. The developed emission factors were used for the adjacent mines and it was found that there were seasonal variations in moisture content of the benches. It was also found that emission factors are site specific.

**Jaiprakash *et al.* (2010)** studied the impact of SPM and PM<sub>10</sub> emission resulting from mines, industries and vehicles in Dhanbad, Jharkhand. AERMOD was used for estimating concentrations of air pollutants. It was found that the mining activities contributed 73% whereas the industrial and vehicular contribution was merely 20% and 7% respectively. The statistical analysis too was carried out for the evaluation of model performance which was found to be 64.9% accurate.

**Kumari *et al.* (2011)** carried out the experiment to determine quartz content in airborne respirable dust (ARD) using FTIR spectrometer at Jharia coalfields. GLA-500 PVC membrane filter was used with Personal dust samplers to collect airborne respirable dust at different locations of the mine. The percentage of quartz was found to be less than 1% in almost all working areas. The maximum Exposure Limit (MEL) was equal to 3mg/m<sup>3</sup> in most of the working places while in case of metal mines, the quartz content was found to be more than 5% in many working areas. They proposed that good ventilation and wet drilling controls the dust problem at some locations whereas in some other locations it is required to rotate the workers.

## Chapter 3

### ENVIRONMENTAL AND HEALTH IMPACTS

Particulate matters are generated in almost every mining activities and is the major source of pollution resulting in severe health hazards to miners. The particulate matter of size less than 10 microns are potential threat to environment. So it is important to identify the sources of such pollution and find out the ways to mitigate such problems. The section gives a brief idea about the following:

- Particulate Matters
- Environmental Impacts
- Health Impacts

#### 3.1 PARTICULATE MATTER

The term “dust” refers to the particulate matter generally classified based on its properties such as size, composition, exposure time etc. Normally it is measured in  $\mu\text{g}/\text{m}^3$ .

The fine particulate matters suspended in air is known as dusts. Particulate matter basically consists of solid particles, aerosols compounds, organic and inorganic minute substances etc. This suspension results due to several natural and man-made activities such as volcanic eruptions, soil particulates lifted by weather, mining activities, automobile exhausts, construction activities etc. The Particulate matter in air is characterized by the size of particulates it contains which varies from 1 to 100 microns. The size under consideration remains from  $1\mu\text{m}$  to  $20\mu\text{m}$ , the earlier one is known as fine particulate matters while later is termed as coarse particulate matter. The finer the particulate matter there is the chances of it being getting suspended and carried further while the coarser settles down quickly. Based on the size, the particulate matters are of following types:

- **SPM:** These are the particles in the air of all sizes. It is a complex mixture of organic substances present in the atmosphere in the form of both as solid particles and liquid droplets. They include dusts, flumes, smokes and aerosols.
- **PM<sub>10</sub>:** These are the particles which has the diameter less than  $10\mu\text{m}$ . They are commonly called as coarse particles coming out of roads, industries as well as particles formed under combustion.

- **PM<sub>2.5</sub>**: The particulate matter which has the size less than 2.5µm is known as PM<sub>2.5</sub>. These are usually called as fine particles which contains secondary aerosols, combustion particles, re-condensed organic metallic vapours and acid components.
- **TSP**: these are the total suspended particulates having the nominal size of the particle diameter upto 50 µm. It is measured in µg/m<sup>3</sup>. It contains larger particulates, RSPM, PM<sub>10</sub>, PM<sub>2.5</sub> and aerosol compounds all in it, so it is not quite good indicator of health related issues since the larger particulates do not penetrates into the human being.
- **Ultrafine Particles**: These are the particles having size less than 1µm. They are not visible to the naked eyes.
- **Coarse Particles**: These are the particles which has the size 2.5 µm to 10µm. They are inhalable.

### 3.1.1 Sources

Mining activities mostly produces dust particulate matters which results due to the mining practices and ore processing. Though the generation is not uniform and so does the effects. Some sources are linear while some are complex. There are several activities which contributes to the particulate matter generation.

In mines the particulate matter generation results due to the following activities:

- Removing vegetation and top soil
- Drilling and blasting overburden
- Drilling and blasting ores
- Haul roads
- Transporting and stockpiling overburden
- Extracting, transporting and dumping ores
- Crushing ores
- Ore beneficiation
- Workshop operations
- Rehabilitation and backfilling etc.

The particulate matters generated due to above activities are commonly called as mine dusts. The surface mining produces large amount of particulate matters than underground mining. In open cast mines the removal of huge overburden requires drilling, blasting and use of

dumpers, draglines and shovels which produces large amount of particulate matters. The ore mining which involves drilling, blasting and use of surface miners generates huge amount of dust particulates. These ores are than loaded and transported via haul roads resulting in generation of particulate matters. The open face of overburden dumps too are potential source of particulate matter generation.

### **3.2 ENVIRONMENTAL IMPACTS**

The generation of particulate matter is unavoidable in open cast mining activities. These particulates when becomes airborne brings unfavorable changes to the environment and ecology of the mining zones. The mining of iron and manganese brings inevitable alterations to the surroundings by deforestations, air and water contaminations, soil erosions and changing the climate. There are a number of ways in which iron and manganese ore mining causes environmental damages, such as:

- The land use pattern is altered
- The flora and fauna of the place is affected
- The natural topology of the place changes
- The water table goes down, surface water and natural drainage is affected
- Water pollution
- The air gets polluted
- The agricultural lands gets affected
- Noise pollution
- Loss of biodiversity etc.



**Figure 3.1** Particulate generation from Blasting Operation

### 3.3 HEALTH IMPACTS

The particulate matters generated due to mining operations when inhaled leads to development of several diseases such as Pneumoconiosis like silicosis, asbestosis, siderosis etc. visual disorders, nervous disturbances etc.

The major health impact due to mine dusts are on respiratory system, though the system has its own defense mechanisms against particulate matters but the finer particles (PM<sub>2.5</sub>) still has the severe effect on it. However the coarser particles (PM<sub>10</sub>) can also leads to adverse health effects. The more coarse particles severely effects the visibility.

The air we breathe goes to nasal and passes through the trachea and bronchioles to enter into alveoli where oxygen is transmitted into blood. When this air is contaminated with dusts containing fine particulate matters, it gets deposited on the lung surface and subsequently there occurs the hindrance to oxygen exchange. The coarser particles of the particulate matters are taken care by the alveolar macrophages consisting of phagocytes. But, if the particles had the composition of silica then this macrophages gets destroyed and the lung is left with silica and destroyed macrophages. When this destruction exceeds to a larger quantity scar tissues are formed which further results in degradation of the respiratory cycle.

The figure below depicts the particulate matter particle size and penetration in respiratory tract

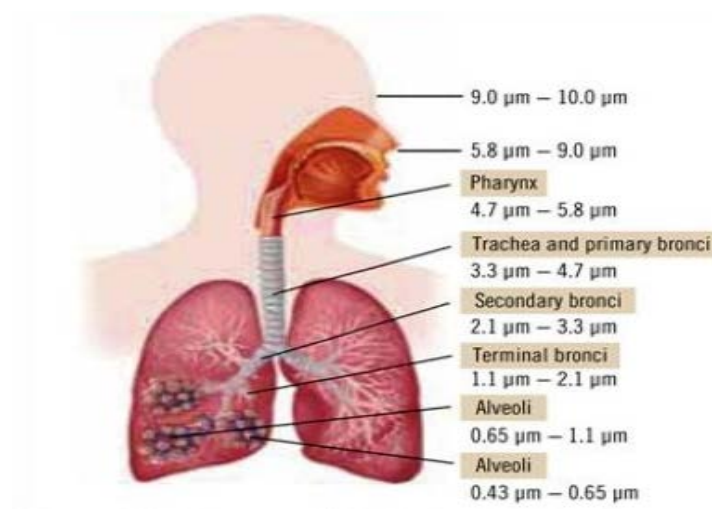

**Figure 3.2** Dust particle size and penetration in respiratory tract

(Source: [www.allaboutfeed.net](http://www.allaboutfeed.net))

It is not only the size of the particulates that matters but the composition of the substances present in dust particulate matter are equally important to be considered to analyze the health impacts.

### 3.3.1 Pneumoconiosis

It is a type of lung disorder caused due to inhalation of mineral particulates in which areas of the lungs are temporarily damaged because of inflammation. When this continues for longer period results in formation of tough fibrous tissue deposits known as fibrosis. Fibrosis stiffens the lungs and interferes the oxygen and CO<sub>2</sub> exchange. Pneumoconiosis sometimes does not cause any symptoms but they generally shows cough (with or without mucus), wheezing, and shortness of breath especially during physical activities. Severe pneumoconiosis results in bluish tinge of lips and fingernails even in more advanced stage leg swelling and much strain on heart is observed.

**Types:** Pneumoconiosis is usually divided into three groups:

- **Major-** Here the inhalation results in major fibrosis such as: Asbestosis, Silicosis, Coal worker's pneumoconiosis, talcosis etc.
- **Minor-** In this type there is minor fibrosis such as: Kaolin (china clay) pneumoconiosis, pneumoconiosis due to clay, mica, feldspar etc.
- **Benign-** In this type there is no reaction in the lungs but dust particulate deposition casts a shadow in X-ray of the lung. There is no fibrosis and no disturbances occurs in the functioning of lung.

Some important pneumoconiosis generally found in miners are

- Asbestosis (due to asbestos)
- Aluminosis (due to aluminum dust particulates)
- Baritosis (due to barium dust particulates)
- Berylliosis (due to beryllium and its compound)
- Coal worker's pneumoconiosis
- Silicosis (due to dust particulates containing free crystalline silica)
- Siderosis (due to iron ore dust particulates)
- Stannosis (due to tin oxide dust particulates)
- Talcosis (due to talcum dust particulates)



- Hard metal diseases (due to titanium, tantalum, chromium, nickel, cobalt etc.)
- Mixed dust fibrosis (due to less fibrogenic dust particulates like iron, carbon etc)
- Pneumoconiosis depends on the composition, concentration, size of the particles, the time of exposure and habit of the patients. It can be prevented by implementing practices such as use of filter masks, frequent regulation of shifts, practicing particulate matter suppression techniques etc.

### **3.3.2 Health hazards associated with Iron Ore dusts**

Iron ore consists mainly of iron oxides (magnetite (  $\text{Fe}_3\text{O}_4$  ) and hematite ( $\text{Fe}_2\text{O}_3$ )), the impurities present in it are : quartz, alumina, lime, magnesium, phosphorous, sulphur, sodium, calcium, titanium, vanadium, tin, cadmium etc. some of these substances are reddish brown solids with physical properties of incombustibility and insolubility in water which when inhaled results in different types of health problems. Exposure to iron ore dust particulates can cause metal fume fever in which the patient suffers with flu like illness. Metallic taste, fever and chills, chest tightness and cough are the symptoms of it. Prolonged and repeated contact may discolor the eyes causing permanent iron staining. Repeated exposure might cause changes which can be seen on chest X-ray. Silica being one of the major constituent of iron ore dust might cause silicosis and other related lung diseases such as irritation and lung cancer. Siderosis is caused due to iron ore dust inhaling which does not cause any symptoms but abnormality could be seen on X-ray. Pulmonary Siderosis is one kind of pneumoconiosis caused by the long term exposure (inhalation) of iron ore dust particulates (Banerjee, Wang et al. 2006).

According to OSHA the permissible exposure limit is  $10 \text{ mg/m}^3$  averaged over an 8- hour work shift and  $5 \text{ mg/m}^3$  averaged over a 10- hour work shift as per NIOSH.

### **3.3.3 Health hazards associated with Manganese ore dusts**

Manganese ore particulate matters too have potential health impacts if inhaled or swallowed. Inhalation of manganese particulate matters or fumes primarily affects the central nervous system. If the concentration is high then it may cause influenza like illness called as manganese pneumonitis. Manganese can act as either direct neurotoxin or may affect adversely to certain neuro-enzymes. It causes a disease similar to Parkinsonism if one gets exposed to it for a period of 6 months to 2 years in which initially person suffers from headache, asthma, restless sleep or somnolence. Further there is change in personality with

psycho instability associated with restlessness, irritability and a tendency to laugh and cry in appropriately. There is visual hallucination, double vision, impaired hearing, uncontrollable impulses, mental confusion, euphoria and lesser feeling of pain. In advanced phase there may be anemia, excessive salivation, muscle weakness, Parkinson type disorders, tremor of head and impaired gait. Short term high concentration inhalation may leads to results similar to mental fume fever while long term exposure may affect the nervous system with difficulty in walking or cramps of legs, hardness of voice, memory loss, unstable emotions and unusual irritability (Dudka and Adriano 1997).

The permissible exposure limit as per current OSHA standard is  $5\text{mg}/\text{m}^3$  of air.

Thus the environmental and health impacts of Iron and Manganese ore mines have serious issues which needs to be monitored and proper mitigation and control strategies should be devised so that the extraction doesn't leads to destruction.

## Chapter 4

# MODELLING AND CHARACTERIZATION

### 4.1 MODELLING

#### 4.1.1 Introduction

Air quality modeling is a numerical tool used to describe the causal relationship between emissions, meteorology, atmospheric concentration, deposition and other factors. In general air pollution measurement gives important quantitative information about ambient concentration and deposition at a certain locations at specific times. Whereas air quality modelling can give a more complete deterministic description of air quality problem including an analysis of factors and causes. In simple words modelling is the mathematical prediction of ambient concentration of air pollution based on measured inputs.

#### 4.1.2 Models

There are many dust dispersion models available, they are developed in hierarchical order from the shortfalls of the previous one or from the requirements specific to certain conditions. They are described in brief as follows:

**4.1.2.1 Box Model:** In the box model the air shed is taken in the shape of a simple box of homogeneous concentration. The equation governing the Box model is:

$$\frac{dC_v}{dt} = QA + uC_{in}WH - uCWH \text{ ----- (10)}$$

Where,

- Q : emission rate of the pollutant per unit area (g/s)
- C : homogeneous dust concentration within the airshed (mg/m<sup>3</sup>)
- V : volume of the box considered (m<sup>3</sup>)
- C<sub>in</sub> : dust concentration entering the airshed (mg/m<sup>3</sup>)
- A : horizontal area of the box (m<sup>2</sup>)
- L : length of the box (m)
- W : width of the box (m)
- U : wind speed normal to the box (m/s)
- H : mixing height (m)

As stated above the box considered the concentration to be homogenous inside the box which is not the case in practical but still the model predicts average concentration over a large area around the source.

**4.1.2.3 Gaussian model:** This model of dust dispersion is a mathematical model suited for point source emitters (dust generating sources) but it can be used for the non-point source too. This model assumes that after a short period of time the steady state condition exists with regard to air pollutant emissions and meteorological changes (Vardoulakis, Fisher et al. 2003).

Here the model characterizes the pollutant to be releasing as the plume from the stack tip. Thus the model does the calculations regarding the effective vertical displacement of the plume, stack height and the plume dispersion in and around the atmosphere as per the wind (downwind and crosswind directions) and meteorological conditions of the vicinity. The vertical and lateral dispersion thus relies on the atmospheric stability which is a function of the Gaussian curve. The equation below defines the concentration at different heights and lengths from the stack tip:

$$C(x, y, z) = \frac{Q}{2\pi u \sigma_y \sigma_z} \left\{ \exp\left(\frac{-(z-h)^2}{2\sigma_z^2}\right) + \exp\left(\frac{-(z+h)^2}{2\sigma_z^2}\right) \right\} \left\{ \exp\left(\frac{-(y)^2}{2\sigma_y^2}\right) \right\} \dots\dots\dots (11)$$

Where,

- C : concentration of the dust emitted.
- Q : emission rate
- $\sigma$  : diffusion values along the axes defined experimentally.
- Y : horizontal distance from plume axis
- Z : height from the ground level
- H : emission height.

The Gaussian distribution has certain assumption pertaining to the dust modelling. Such as:

- The emission rate was taken continuous and constant
- Plume spread has the normal distribution
- The terrain was taken relatively flat (no crosswind barriers)
- Wind speed and its direction was taken uniformThe total reflection of the plume takes place at the surface.

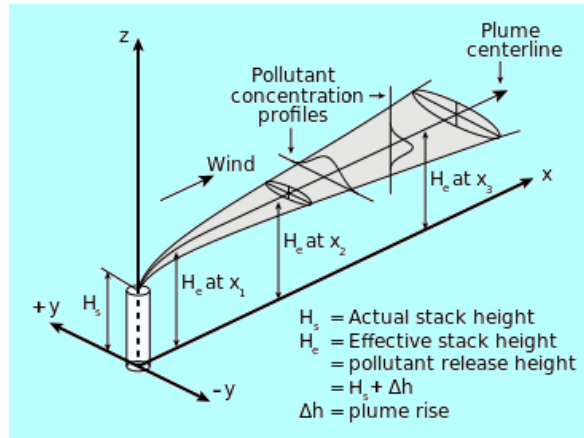

**Figure 4.1** Gaussian plume

(Source: Turner, D, B., 1994, Workbook of Atmospheric Dispersion Estimates: An Introduction to Dispersion Modeling, Lewis publishing)

The plume rise results due to the entrainment (mixing of plume with ambient air) and buoyancy which brings the pollutant lofted into the atmosphere. Thus the final height or say effective stack height ( $H$ ) is the summation of physical stack height ( $h$ ) and plume rise ( $\Delta h$ ). The plume rise is calculated from the Briggs' plume rise equation:

$$\Delta h = \frac{\left(1.6 \times F^{\frac{1}{3}} \times x^{\frac{1}{3}}\right)}{u} \text{----- (12)}$$

Where,

$\Delta h$  : plume rise above stack.

$$F = \frac{g}{\pi} \times V \left( \frac{(T_s - T_a)}{T_s} \right) \text{----- (13)}$$

$F$  : Buoyancy flux

$u$  : average wind speed

$x$  : downwind distance from the stack

$g$  : acceleration due to gravity ( $9.8 \text{ m/s}^2$ )

$V$  : volumetric flow rate of the Dust from the stack

$T_s$  : temperature of stack dust

$T_a$  : temperature of ambient air.

The shapes of plume depends on atmospheric stability conditions which is the function of environmental lapse rate (ELR) and dry adiabatic lapse rate (DLR). The relations below tells how plume behaviour will be subjected to atmospheric stability, if:

- ELR > DLR, atmosphere is stable
- ELR >> DLR, atmosphere is very stable
- ELR = DLR, atmosphere is neutral
- ELR < DLR, atmosphere is unstable

**4.1.2.4 Eulerian model:** Eulerian model is based on the principle of conservation of mass equation for the pollutant. The Eulerian equation,

$$\frac{\partial \langle C_i \rangle}{\partial t} = -\bar{U} \cdot \nabla \langle C_i \rangle - \nabla \cdot \langle C_i U' \rangle + D \nabla^2 \langle C_i \rangle + \langle S_i \rangle \quad \text{----- (14)}$$

Where,

$$U = \bar{U} + U'$$

U : wind field vector U(x, y, z) in m/s

$\bar{U}$  : average wind field vector in m/s

U' : fluctuating wind field vector in m/s

$$c = \langle c \rangle + c'$$

c : pollutant concentration in mg/m<sup>3</sup>

$\langle c \rangle$  : average pollutant concentration in mg/m<sup>3</sup>

c' : fluctuating pollutant concentration in mg/m<sup>3</sup>

D : molecular diffusivity in kelvin

$S_i$  : source term in g/s

Is quite difficult to solve as it has complex mathematical adversities like advection term being hyperbolic and the turbulent diffusion term is parabolic while the source terms are functions of differential equations. This type of equations are computationally expensive and requires optimization in order to reduce the solution time required.

**4.1.2.5 Lagrangian model:** This model predicts the pollutant dispersion based on a shifting reference grid which is based on the prevailing wind direction or the general direction of the dust plume movement. The Lagrangian model has the following form:

$$\langle C(r, t) \rangle = \int_{-\infty}^t \int P(r, t | r', t') S(r', t') dr' dt' \quad \text{----- (15)}$$

Where,

$\langle C(r, t) \rangle$  : average pollutant concentration at location r at time t

$S(r', t')$  : source emission term

$p(r, t | r', t')$  : probability function that an air parcel is moving from location r' at time t' to location r at time t.

The mathematical model has limitations when the results are compared with actual measurements. This is due to the models consideration of the moving reference grid whereas the measurements are made at stationary points.

### 4.1.3 Emission Rates

The emission rates are one of the important and crucial parameter for modelling. There are several sources of particulate matter generation in a mine which makes it cumbersome to identify and imply the correct techniques to find the emission rates still there are some prominent sources which can be considered for the purpose. The emission rates of different mining activities have been calculated on the basis of the modified Pasquill – Gifford formula:

$$C_{x,0} = \frac{Q}{\pi \times u \times \sigma_y \times \sigma_z} \text{----- (16)}$$

Where,

$C_{x,0}$  : the difference in pollutant concentration i.e. downwind and crosswind ( $\text{g/m}^3$ )

$Q$  : emission rate ( $\text{g/s}$ )

$u$  : mean wind speed ( $\text{m/s}$ )

$\sigma_y$  : horizontal dispersion coefficient compiled as a function of downwind distance and stability.

$\sigma_z$  : vertical dispersion coefficient compiled as a function of downwind distance and stability.

The empirical formula for emission factors of different mining activities as been derived by Chakraborty et al (2002) are listed below.

**Table 4.1:** Different mining activities and their Emission Factors

<b>Mining Activity</b>	<b>Empirical Equation</b>
Drilling	$E = 0.0325\{[(100-m)su]/[(100-s)m]\}^{0.1}(df)^{0.3}$
Overburden loading	$E = [0.018\{(100-m)/m\}^{1.4}\{s/(100-s)\}0.4(uhxl)^{0.1}]$
Mineral loading	$E = [\{(100-m)/m\}^{0.1}\{s/(100-s)\}^{0.3}h^{0.2}\{u/(0.2+1.05u)\}\{xl/(15.4+0.87xl)\}]$
Haul road	$E = [\{(100-m)/m\}^{0.8}\{s/(100-s)\}^{0.1}u^{0.3}\{2663+0.1(v+fc)\}10^{-6}]$
Transport road	$E = \{(100-m)s\}/\{m(100-s)\}^{0.1}u^{1.6}\{1.64+0.01(v+f)\}10^{-3}$
Overburden unloading	$E = [1.76h^{1/2}\{(100-m)/m\}^{0.2}\{s/(100-s)\}^2u^{0.8}(cy)^{0.1}]$
Mineral unloading	$E = 0.023[\{(100-m)sh\}/\{m(100-s)\}]^2(u^3cy)^{0.1}$
Exposed overburden dump	$E = [\{(100-m)/m\}^{0.2}\{s/(100-s)\}^{0.1}\{u/(2.6+120u)\}\{a/(0.2+276.5a)\}]$
Stock yard	$E = \{(100-m)/m\}^{0.1}\{s/(100s)\}\{u/(71+43u)\}[\{cy/(329+7.6cy)\} + \{lx/(30+900lx)\}]$
Coal handling plant	$E = [\{(100-m)/m\}^{0.4}\{a^2s/(100-s)\}^{0.3}\{u/(160+3.7u)\}]$
Workshop	$E = [0.064\{(100-m)/m\}^{1.8}\{as/(100-s)\}^{0.1}\{u/(0.01+5u)\}10^{-4}]$
Exposed pit surface	$E = [2.4\{(100-m)/m\}^{0.8}\{as/(100-s)\}^{0.1}\{u/(4+66u)\}10^{-4}]$
Overall mine (SPM)	$E = [u^{0.4}a^{0.2}\{9.7+0.01p+b/(4+0.3b)\}]$
Overall mine (SO <sub>2</sub> )	$E = a^{0.14}\{u/(1.83+0.93u)\}[\{p/(0.48+0.57p)\} + \{b/(14.37+1.15b)\}]$
Overall mine (NO <sub>x</sub> )	$E = a^{0.25}\{u/(4.3+32.5u)\}[1.5p + \{b/(0.06+0.08b)\}]$

Parameters and units and symbols used in the above equations are:

- m : Moisture content (%)
- s : Silt content (%)
- u : Wind speed (m/s)
- d : Hole diameter (mm)
- f : Frequency (no. of holes/day)
- h : Drop height (m)
- l : Size of loader (m<sup>3</sup>)
- v : Average vehicle speed (m/sec)
- c : Capacity of dumper (ton)
- a : area (km<sup>2</sup>)
- y : Frequency of unloading (no. / Hr)
- x : Frequency of loading (no. / Hr)
- p : Mineral production (Mt/yr)
- b : OB handling (Mm<sup>3</sup>/yr)
- E : Emission rate (g/sec)



#### **4.1.4 AERMOD View**

The term AERMOD is an abbreviation of American Meteorological Society-Environmental Protection Agency Regulatory Model (AERMOD). AERMOD View is a complete and powerful air dispersion modeling package that seamlessly incorporates the popular U.S. EPA models, AERMOD, ISCST3, and ISC-PRIME into one interface without any modifications to the models. These models are used extensively to assess pollution concentration and deposition from a wide variety of sources.

An air dispersion model is a computational way of predicting the concentration based on the knowledge of emission characteristics, topography and meteorology. AERMOD was developed by the AERMIC (American Meteorological Society (AMS)/United States Environmental Protection Agency (EPA) Regulatory Model Improvement Committee). AERMOD model is applicable to both rural and urban areas, surface and elevated releases flat, complex terrain, and multiple sources such as point, area and volume sources(Holmes and Morawska 2006).

#### **Features**

- Creates impressive presentations of the model results with the easy and intuitive graphical interface of AERMOD View. The project can be customized using display options such as transparent contour shading, annotation tools, various font options, and specify compass directions.
- It specifies the model objects such as sources, receptors and buildings graphically so that access to the mode in which parameters needed to be modified could be attained at ease.
- It can import base maps in a variety of formats for easy visualization and source identification.
- The major digital elevation terrain formats - USGS DEM, NED, GTOPO30 DEM, UK DTM, UK NTF, XYZ Files, CDED 1-degree, AutoCAD DXF are used.
- It can interpret the effects of topography by displaying the model results with 3D terrain using the powerful 3D visualization.
- Completes the building downwash analysis effectively and quickly using the necessary tools which is incorporated in it.
- Prepares the meteorological data quickly and accurately using the step-by-step meteorological pre-processing interface.

- It performs integrated post-processing with automatic contouring of results, automatic gridding, blanking, shaded contour plotting and posting of the results.
- Compares different models rapidly.
- Summarizes the modeling input in professionally designed reports using report-ready formats.

Basically AERMOD is a steady-state plume model. It uses, processed meteorological observations such as wind speed, wind direction, humidity, rainfall, temperature which is first preprocessed by AERMET and along with the emission characteristics (as mentioned in the emission rates) it estimates the concentration of the particulate matter released by different sources. The data flow diagram briefly explains how the model works.

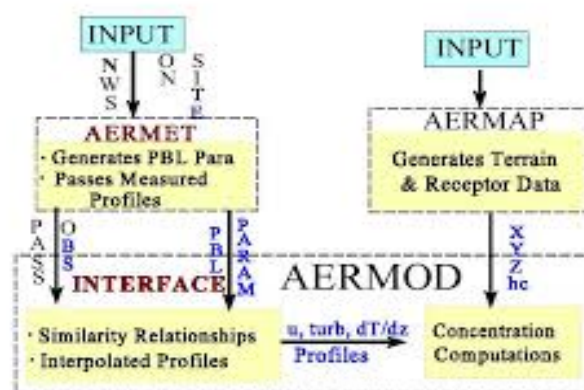

**Figure 4.2** Data flow Diagram of AERMOD

(Source: <http://www.weblakes.com/guides/aermod/section2/index.html>)

There are some of the required inputs to the AERMOD as listed below:

- Latitude and longitude of the place under consideration
- Base map of the area where modelling is to be performed.
- The pollutants to be modelled
- Hourly met data.
- Receptors
- Terrain data
- The emission factors of the generating sources
- Source locations etc.

AERMOD has the following improved functionality than its predecessor ISC:

- Areas where there are increased surface roughness and heat flux and there is enhanced dispersion this model is effective.
- It can have continuous functions for both elevated and surface release.
- It can treat building downwash.
- It can treat the effects of the terrain on dispersion.
- It can account for both the upward and downward dispersion.

**AERMET View:** It is the Lakes Environmental interface for the US EPA AERMOD meteorological preprocessor, AERMET. The AERMET program pre-processes meteorological data into a format suitable for use by the AERMOD air dispersion model.

It uses the meteorological information such as wind, temperature, cloud cover, humidity, rainfall, ceiling height along with surface characteristics such as surface roughness, albedo, and bowen ratio as the input to it in order to estimate the sensible heat flux which further is utilized to find the surface shear stress exerted by the turbulence and speed of the wind. The mixing height is computed by the use of sensible heat flux while the night time boundary layer is computed by surface shear stress. All this estimated and computed information like sensible heat flux, surface parameters and shear stress, the mixing height and boundary conditions are fed to the AERMOD. Meteorological preprocessor for AERMOD is basically a program which preprocesses the raw met data into a format suitable for it. AERMET creates two files for the input to AERMOD:

- Surface file which has the estimated boundary parameters and
- Profile file containing multiple level observations of wind speed, wind direction, temperature and standard deviation of the fluctuating components of wind.

**AERMAP:** It is a terrain preprocessor which gives the relationship between the plume behaviour and terrain features. This generates the height and location of each receptor locations along with it also gives the model the information regarding the effects of hills on the wind. Thus AERMOD uses these information to carry out the dispersion modelling. It can handle all types of terrains from flat to complex. To obtain the height and base elevation for a receptor this preprocessor needs to be run. AERMAP produces two main outputs:

- Receptor output file (\*.rou) which is used as the input to AERMOD for receptor pathway.

- Source output file (\*.sou) which contains the calculated base elevations for all the sources.

### **Steps for Modelling:**

#### **I. Met file preparation:**

##### **a. Using Rammet view**

- Hourly met data in excel sheet is prepared.
- Processed met file then is prepared from Rammet view. For this two files are prepared:
  - Hourly surface data file in Samson format (.sam)
  - Mixing height file in scam format is prepared (.txt)
- Surface data file and mixing height file is then selected simultaneously as the input to the Rammet view and then is run as PC Rammet.
- Output file is then generated with .met extension in ISC format which is the processed met file.
- The output file is present in both text and grid format. Obtained WRPLOT consists of windrose diagram and frequency distribution bar graph for both wind speed and stability class.

##### **b. Using AERMET view:**

- The first step is same as the Rammet view preprocessor. While in the next we need to upload only the Hourly surface data file in Samson format (.sam).
- In the upper air data we can select either standard AERMET or upper air estimator. Here upper air estimator is selected with site time zone (UTC +5 (Islamabad) for the present site).
- In additional surface parameters Anemometer height has to be mentioned.
- In sector segment of the AERMET view we have two options one of which is to use file of sector and surface parameters and another is to specify the sector and surface parameters manually. Here the sectors are divided manually into four with selection of period on the seasonal basis while specific surface parameters (Albedo, Bowen Ratio and surface roughness) for each sector is entered under each column by clicking within the cell for seasons of each sectors.

- Finally the AERMET view is ready to run. After running, Two files are produced by the AERMET model for input to the AERMOD dispersion model, the Surface (\*.SFC) and the Profile (\*.PFL) met files. Surface file contains observed and calculated surface variable, one record per hour and Profile file contains the observations made at each level of a site-specific tower.

## **II. Line and Volume source selection**

- Selecting the source pathway from the options
- Line / Volume source is selected by manually entering the data in the table (coordinates, release heights, etc.) or can be drawn by selecting the drawing tool and moving it on the haul road direction. Other related data such as emission rate, vehicle height and width (for calculating plume characteristics) etc.
- One of the most important information is emission rate which is established either through field measurement in working mines & extrapolating the information to required capacity in expansion or using empirical equations and putting the value of variables from site conditions
- After processing of Line / Volume source data in AERMOD, isopleths for fugitive dusts (Line Source) and isopleths for fugitive dusts (Volume Source) are generated.

## **III. Control pathway**

Here output type is selected as the concentration as was looking for the PM<sub>10</sub> concentration. Non default option is taken as flat and elevated.

- Pollutant type as mentioned above is taken PM<sub>10</sub> with exponential decay and averaging time option is taken to be 1 hour and 24 hour for the period of the months while dispersion coefficient is chosen as rural.
- Non default regulatory option is selected as flat and elevated and reception elevations/hill heights is selected to run AERMOD using AERMAP receptor output file.

## **IV. Receptor Pathway**

Here the number of receptors, coordinates of the grid, center of it, uniform and non-uniform Cartesian grid, receptor center coordinates, no of points, spacing is entered manually thereby generating receptor on its own with coordinates.

## V. Meteorology Pathway

- Surface and profile met file are imported here which was generated by AERMET preprocessor.
- Base elevation (above mean sea level for the site has to be provided).
- Wind speed and category has default selection.

## VI. Terrain Processor

- This is used to specify the terrain elevation files to be used for the project.
- Selecting a Map Type from the drop down list. Here STRM3 (global- 90m) is selected to import Digital elevation model files (DEM Files).
- Then the region is selected upto which the terrain data has to be used. It can be entered manually or by selecting the region from the tool provided with the software (10000\*10000 km<sup>2</sup> is used for the purpose).

## VII. Running the AERMOD view

AERMOD view is ready to run which is selected from the run menu as AERMOD (available in the menu bar). The figure below shows the AERMOD 8.2 volume source modelling with isopleths window:

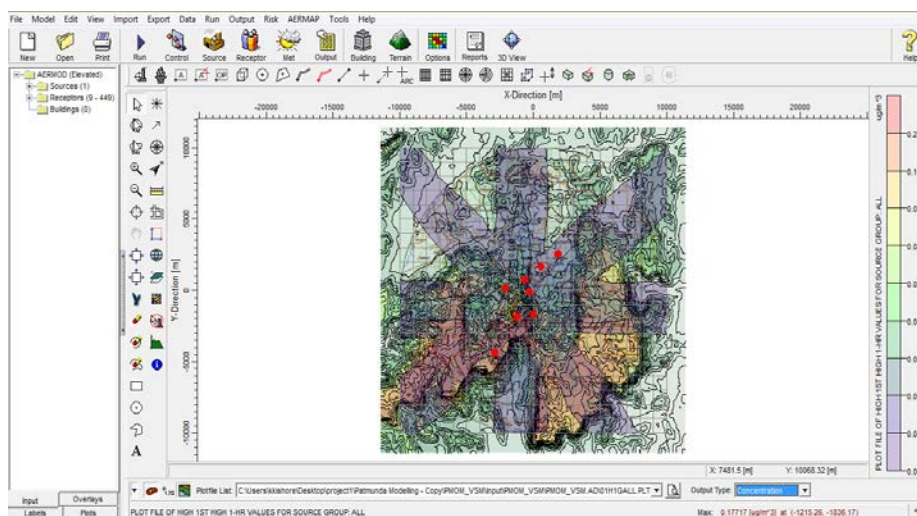

**Figure 4.3** AERMOD 8.2 Window with Line volume source modelling

Isopleths are line or curve drawn on a map connecting points having the same numerical value of some variable. The isopleths are generated during line area source, line volume source and open pit source modelling.

## **4.2 MONITORING**

The associated health impacts due to mine dusts are of grave concern so it is required to monitor the amount of particulate matters generated and their sources. Primarily the monitoring is concerned with quantification of particulate matters emitted which is done by sampling.

Monitoring of particulate matter is required to be done in order to assess the amount of particulate matter that is being emitted from different operations. The monitoring results will also help in finding out whether the emissions are exceeding the limits prescribed by NAAQs (National Ambient Air Quality standards) and DGMS (Director General of Mine Safety). DGMS clearly specifies that the exposure of workers to the respirable dust should be to an extent that are reasonably practicable and within the limits. The regulation prescribes that the monitoring shall be carried out at least every six months in general. If the monitoring result shows the concentration in excess of 50% or 75% of the maximum allowable concentration then the subsequent measurements shall be carried on every three and one month respectively.

To estimate the concentration of particulate matters in mines the first and foremost step is sampling. It is the collection of particulate matter samples that represents the total emission at a particular location. There are different dust sampling methods available for the quantification of particulate matters (Crocker 1991). These are:

**1. Filtration:** These samplers are based on filtration of the particulates of desired pollutants. In this method the particulate matter is passed through filtering media after being collected from the surroundings. It is one of the mostly practiced method since it can collect and segregate the respirable size fraction of the particulate matter which are the source of severe health issues. The instruments used in this methods are: Gravimetric Dust Sampler (GDS), Safety in Mines Personal Dust Sampler (SIMPEDS), Safety in Mines Quarry Dust Sampler (SIMQUADS), Personal Dust Samplers (PDS), High Volume Samplers (HVS), etc.

**2. Inertial precipitation:** This method is based on three principles namely:

- Impaction where dust particulates gets deposited on the instrument when kept in the dusts and measures it directly. E.g. Konimeter
- Centrifuging is the collection of dust particles through centrifugal actions. E.g. Centrifuge.
- Impingement is the way by which dust are impinged on the instrument. E.g. Midget impinge.

**3. Sedimentation:** In this method of sampling the particulate matters are collected in a vertical cylinder and is allowed to settle on the glass slide from where it is taken for the microscopic study.

**4. Thermal precipitation:** In this method heat is used to precipitate the particulates. The body surrounding the dust is heated which result in the formation of the gradient zone around it then the glass cover slips are used to collect the dust particulates. The glass slide then is taken for microscopic analysis.

**5. Electrical precipitation:** ESPs are both sampling and controlling arrangements where dust particles are charged oppositely to that of the electrodes and are collected accordingly.

**6. Optical Methods:** This method uses the scattering of light due to hindrance in its path as the basic principle. This can be used for the particle size greater than the wavelength of light. The intensity of scattered light can be given as:

$$\frac{I_s}{I_0} = KND^2 \text{----- (3)}$$

Where,

$I_s$  : intensity of scattered light

$I_0$  : intensity of incident light

$N$  : No. of particles per unit volume

$D$  : diameter of particles

$K$  : is the constant depending on the refractive index, the shape of particles and the absorption co-efficient as well as the wave length of light, the distance of the point of observation from the dust cloud and angle of scattering.

For particles of smaller diameter Rayleigh's equation can be used

$$I_s = D^6 \text{----- (4)}$$



Tydalloscope, RAM, Simslin are commonly used instruments based on this method.

Sampling is carried out as per the guidelines of CMR 1957 and DGMS circular. Mostly mines use personal dust sampler, gravimetric samplers and optical samplers for the sampling purpose.

#### 4.2.1 PM<sub>10</sub> SAMPLING

In the present work the PM<sub>10</sub> sampling is performed by Respirable dust Sampler ENVIROTECH APM 460 NL.

**Principle:** Air is drawn through a size-selective inlet and through a 20.3 cm × 25.4 cm filter at a flow rate of about 1132 liter per minute. The particles with aerodynamic diameter less than the cut-point of the inlet are collected by the glass fiber filter paper. The concentration can be determined by the difference in filter weights prior to and after sampling. Concentration of PM<sub>10</sub> in the designated size range is calculated by dividing the weight gain of the filter by the volume of air sampled by it.



**Figure 4.4** Respirable Dust Sampler (ENVIROTECH APM460NL)

**Sampler:** It is a typical cyclonic fractionating sampler for respirable particulate matter consisting of rotameter, voltage stabilizer, blower, time totalizer, protective housing and filter holder capable of supporting a 20.3 cm × 25.4 cm glass fiber filter paper. A schematic sampler is shown in the Figure 3-4.

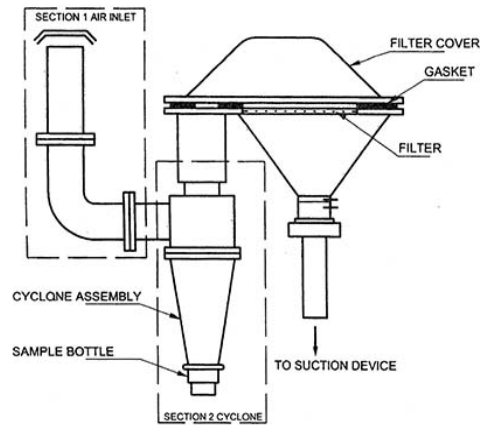

**Figure 4.5** A schematic sampler  
(Source: IS 5182 (Part 23), 2006)

**Calculation:** The calculation of volume of air sampled is given by the equation:

$$V = QT \text{ ----- (5)}$$

Where,

- V : is the volume of air sampled, in m<sup>3</sup>
- Q : is the average flow rate, in m<sup>3</sup>/min
- T : is the total sampling time, in min.

The PM<sub>10</sub> concentration in ambient air can be calculated by the equation:

$$PM_{10} (as \mu g / m^3) = \frac{(W_2 - W_1)}{V} \times 10^6 \text{ ----- (6)}$$

Where,

- PM<sub>10</sub> : the mass concentration of particulate matter less than 10 micron diameter in μg/m<sup>3</sup>
- W<sub>1</sub> : is the initial weight of the filter in gram
- W<sub>2</sub> : the final weight of the filter after sampling in gram
- V : the volume of air sampled, in cubic meter
- 10<sup>6</sup> : the conversion of g to μg.

The purpose of the PM<sub>10</sub> sampling is to monitor and quantify the amount of particulate matter of particle size less than 10 microns present in the air. As per the National Ambient Air Quality Standards the PM<sub>10</sub> limits are as shown in the table.

**Table 4.2:** National ambient air quality standard for Particulate Matter PM<sub>10</sub>

Pollutant	Time weighted Average	Industrial/ Residential Area	Ecologically Sensitive Areas
PM <sub>10</sub> (µgm/m <sup>3</sup> )	Annual	60	60
	24 hour	100	100

#### 4.2.2 PM<sub>2.5</sub> SAMPLING

**Principle:** Sampler draws the ambient air at the constant volumetric flow rate of 16.7 l pm through the cyclones/impactors. Here the suspended particulate matter of aerodynamic diameter less than 2.5 microns are separated and is collected on a 47 mm PTFE (polytetrafluoroethylene) filter. The filter is weighed before and after the sampling, the difference gives the amount of particulate matter concentration (PM<sub>2.5</sub>) in µ gm/m<sup>3</sup>. The flow rate is maintained by volumetric flow controller which is governed by microprocessor. It also averages and stores the ambient temperature, ambient pressure, volumetric flow rate and coefficient of variation of flow rate for the entire sample run time.

The procedure of sampling is same as PM<sub>10</sub>.



**Figure 4.6:** PM<sub>2.5</sub> sampler (ENVIROTECH APM550)

The APM 550 is a manual method for sampling fine particles based on impactor designs standardized by USEPA for ambient air quality monitoring. Air enters through omnidirectional inlet (cut point of 10 microns) the air then proceeds to the second impactor

that has aerodynamic cut point of 2.5 microns which then is passed through a 47mm diameter Teflon filter membrane that retains the fine particulates.

**Calculation:** The concentration of the collected particulate matter can be measured by the following equation:

$$M_{2.5} = (M_f - M_i) \text{mg} \times 10^3 \mu\text{g} \text{----- (7)}$$

Where,

- $M_{2.5}$  : represents total mass of fine particulate collected during sampling period in  $\mu\text{g}$
- $M_f$  : the mass of the filter paper after sampling in mg
- $M_i$  : the initial mass of the conditioned filter before sample collection in mg
- $10^3$  : unit conversion factor from mg to  $\mu\text{g}$

If total volume through the sampler is not known then it can be found by using the relation:

$$V = Q_{avg} \times t \times 10^{-3} \text{m}^3 \text{----- (8)}$$

Where,

- $V$  : the total sample value in  $\text{m}^3$
- $Q_{avg}$  : is the average flow rate over the entire duration of the sampling period in L/min
- $t$  : the duration of sampling period in min
- $10^3$  : the unit conversion factor from L to  $\text{m}^3$

Thus the concentration then can be found by the relation:

$$PM_{2.5} = \frac{M_{2.5}}{V} \text{----- (9)}$$

Where,

- $PM_{2.5}$  : the mass concentration of  $PM_{2.5}$  particulates in  $\mu\text{g}/\text{m}^3$
- $M_{2.5}$  : the total mass of fine particulate collected during sampling period in  $\mu\text{g}$
- $V$  : the total volume of air sampled in  $\text{m}^3$

As per the National Ambient Air Quality Standards, the PM<sub>2.5</sub> limits are as shown in the table:

**Table 4.3:** National ambient air quality standard for Particulate Matter PM<sub>2.5</sub>

Pollutant	Time weighted Average	Industrial/ Residential Area	Ecologically Sensitive Areas
PM <sub>2.5</sub>	Annual	40 µgm/m <sup>3</sup>	40 µgm/m <sup>3</sup>
	24 Hours	60 µgm/m <sup>3</sup>	60 µgm/m <sup>3</sup>

### 4.2.3 Personal Dust Sampler

This is a light weight hand held battery operated sampler which makes the monitoring of particulate matter exposure of miners convenient. It can measure both suspended and respirable particulate matters just by changing the cyclone assembly attached to it. Cyclone is designed for a cut off size of 5µm with a glass fiber filter of 37mm diameter as per DGMS recommendation. The sampling collects the particulate matter on the filter paper which can further be analyzed for its constituents. It is generally mounted on the body of the miners like on waist and monitors his exposure to the dust particulates. Flow rate is maintained as per the breathing rate of the person. The figure 5 shows a personal dust sampler:



**Figure 4.7** A Personal dust sampler (ENVIROTECH APM 801)

### 4.2.4 Dust Track II Aerosol Monitor 8532

The Dust Track Aerosol Monitor 8532 is a handheld battery operated, data logging, light scattering laser photometer that gives real time aerosol mass readings. It measures aerosols

like dusts, smokes, fumes and mists through the light scattering principle. It is a class I laser based instrument.



**Figure 4.8** DustTrack II Aerosol Monitor 8532

At first zero calibration is done by zero filter then size selective impactors are attached to the inlet. The instrument has three modes of operations: survey, manual and log, based on its data logging facilities and real time operations. The figure shows the DustTrack II Aerosol Monitor:

### **4.3 CHARACTERIZATION**

Particulate matter characterization is the process by which the constituents of the particulate matter can be identified along with its composition quantitatively. Characterization of airborne particulate matter resulting due to mining activities can provide the information regarding the sources and hazards on human exposure. There are several ways available for the purpose some of the useful one are: XRD (X-ray diffraction), SEM (Scanning electron microscopy), FTIR (Fourier Transform infrared Spectroscopy), Atomic Absorption Spectrophotometry etc.

The first and foremost step for the particulate matter characterization is the extraction of the particulate matters from the filter paper which can be done either by microwave extraction or hot acid digestion or by mere combustion.

**Combustion:** The combustion is the burning down of the filter paper in the absence of sufficient air inside a muffle furnace. This system doesn't prove to be the feasible way of extraction since the glass melts down instead of burning and the crushed powdered form has high silica and oxygen contents. So there is always a scope of high error while characterization is performed.

**Microwave Extraction:** In this method the filter paper is first cut into strips of 1"× 8" inches. The particulates are extracted from the filter strip by an HCl/HNO<sub>3</sub> acid solution by using acid digestion procedure. After cooling, the digested solution is rinsed to a volumetric flask and further diluted to a volume. The insoluble matters are removed through filtration. For the microwave digestion of the particulate sample the Teflon containers are used and the sample is kept in a plastic desiccator before being fed to the microwave oven.

**Acid Digestion:** In this method of extraction, first the filter paper is cut into strips and then is washed by Isopropyl alcohol in a beaker. Then it is allowed to evaporate so that the beaker remains with the particulates. This sample is then acidified with nitric acid or Hydrochloric acid, which heats the sample and the volume is reduced substantially. The digested is filtered and diluted to certain volume. This solution is further diluted by double distilled water and the solution is taken for the analysis by spectrophotometer or other such instruments (Avie, M. et al., 1999).

Thus there are two types of samples available for the characterization one in powdered form i.e. Solid and the other as a solution i.e. in liquid form. Based on this there are different methods of analysis. The X-ray and Electron microscopy deals with the solid samples whereas the Spectrophotometer can be used for the liquid samples. Some of the commonly practiced characterization techniques are given below:

**XRD:** It is an analytical technique in which the wavelength of X-ray interacts with the matter and based on the physical properties of the matter the substance is identified. This technique for long was suited only for the well-ordered crystalline structures. It can successfully identify phase composition, orientation, crystallinity and stress of the atoms. SAXS (small angle x-ray scattering) uses Cu K $\alpha$  x-ray scattering at very small angles to probe structure of electron density. This technique can be utilized in finding the polymer structure, biological membrane structure, structure of catalysts, silica, coal and other porous materials, nano precipitate size and disparity in alloys. Powder X-ray diffraction can give the information regarding lattice parameters, phase identity, phase purity, crystallinity, and percent phase composition. A much better approach of this kind is through XRF. X-ray fluorescence is the technique in which the emission of characteristics (secondary/fluorescent) X-ray from the material takes place on being bombarded with high energy X-ray or gamma rays. This phenomena is used in elemental and chemical analysis of the metals, chemicals, glass, forensic science, archeology, geochemistry, building materials and several other fields

**SEM:** Scanning electron microscope is the system in which the focused beam of electrons scans the sample and captures the microscopic information about it. In this method the electrons interact with the atoms of the sample generating signals as the function of the surface characteristics and composition of it. SEM can have the resolution better than one nanometer. The surface topography is known because of the result of the emitted secondary electrons out of the atoms. The SEM generally needs the polished and ultra-smooth surface for that the specimen for EDS (energy dispersive X-ray spectroscopy) is coated with carbon but that is not the case with metals since this practice would make the specimen conductive and become grounded. So SEM of the mineral or metal sample is examined just in the powdered form without any coating. This practice gives the concentrations in terms of percentage composition of the sample.

**FTIR:** It is a method of measuring infrared absorption spectrum. Fourier transform infrared spectroscopy is the technique by which the infrared spectrum is obtained from the physical properties of the sample. It collects high spectral resolution over wide spectral region. In this technique light beam of several frequencies are shined on the sample and the absorption is measured this is repeated for different wavelengths. For the characterization of particulate matters the samples are first freed from organic matter and is then mixed with certain compounds (KBr) in order to improve the spectrum. Then pellets are prepared and spectra is taken normally in some specified region. The instrument is set for some scanning frequency (Stuart, 2005).

**Atomic Absorption Spectrophotometer:** This is an analytical technique which is used for the quantitative determination of the elements which uses the absorption property of free atoms from falling optical radiations. Atomic absorption spectrophotometry (AAS) is basically an analytical technique of elemental concentration measurement. The system is very sensitive and can measure down to parts per billion of a gram i.e.  $\mu\text{g}/\text{m}^{-3}$ . The technique makes use of the wavelengths of light specifically absorbed by an element. They correspond to the energies needed to promote electrons from one energy level to another, higher, energy level. The block diagram below explains the overall working assembly of the AAS:



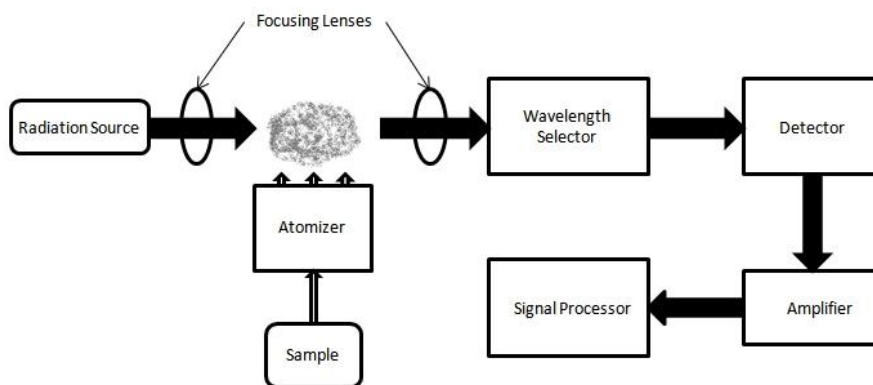

**Figure 4.9** Block Diagram of an Atomic Absorption Spectrophotometry

Atoms of different elements absorb characteristic wavelengths of light. For finding the particular element from the sample is based on the light emitting out of it. The sample is atomized and from a reference the electromagnetic radiation is passed through it. These atomized samples absorbs the radiation based on their quantities present. Greater the amount higher is the absorption. An atomic absorption spectrophotometer needs the following three components: a light source, a sample cell to produce gaseous atoms and a means of measuring the specific light absorbed.

In the present work WFX 130 Rayleigh Atomic Absorption Spectrophotometer is used for the characterization part.

## Chapter 5

### CASE STUDIES

In the present work different iron and manganese ore mines from Sundargarh district of Odisha were taken for the monitoring and characterization purpose while a detailed monitoring and modelling is performed for the Patmunda Manganese Ore Mine (of Orissa Manganese and Minerals Limited) from Sundargarh district of Odisha.

#### 5.1 SPM and PM<sub>10</sub> MONITORING REPORTS OF SOME IRON AND MANGANESE ORE MINES (Source: SPCB Rourkela)

##### 5.1.1 BARSUAN – TALIDIH – KALTA Iron Mines (ML-130) of M/S SAIL

The mine is situated at Tensa and Kalta in Sundargarh district. It is a fully mechanized mine with a production capacity of 8.05 MTPA. The ambient air quality and fugitive monitoring was conducted for PM<sub>10</sub> and SPM at different AAQ monitoring stations on 5<sup>th</sup> and 6<sup>th</sup> of January 2015 the results are shown in the table:

**Table 5.1:** AAQ monitoring result of Barsuan-Talidih-Kalta Iron Mines

Sl No	Locations	Parameters	Concentrations (µg/m <sup>3</sup> )	Prescribed standards (µg/m <sup>3</sup> )
1	Tensa guest house (Buffer zone)	PM <sub>10</sub>	73	100
2	Barsuan guest house (Buffer zone)	PM <sub>10</sub>	56	100
3	Admin building near mine entry gate (Buffer zone)	PM <sub>10</sub>	63	100
4	Near Tanta village (Buffer zone)	PM <sub>10</sub>	52	100
5	Near active mine area (25m from the source)	SPM	721	1200
6	Guest house of Kalta township (Buffer zone)	PM <sub>10</sub>	81	100
7	Kalta basti (Buffer zone)	PM <sub>10</sub>	76	100
8	Kalta admin building (buffer zone)	PM <sub>10</sub>	89	100
9	Near active mining area (25m from source)	SPM	980	1200

### 5.1.2 ORAGHAT Iron Mine of Rungta Sons Pvt. Ltd.

The mine is situated at Oraghat village of Sundargarh district. The mine has a grant of 5.0 MTPA out of which 3.5MTPA is ROM iron ore and remaining 1.5MTPA is dry processing of low grade iron ore from old stacks. The mine was monitored for environmental compliance on 16<sup>th</sup> February 2015. The table below shows the monitoring result of PM<sub>10</sub> at different monitoring locations:

**Table 5.2:** AAQ Monitoring result of Oraghat Iron Mine

Sl No	Locations	PM <sub>10</sub> (µg/m <sup>3</sup> )	Prescribed Standard (µg/m <sup>3</sup> )
1	Mines office building towards northern direction (core zone)	71	100
2	Village Sanindpur towards southern direction (Buffer zone)	78	
3	Village Jalipada towards eastern direction (Buffer zone)	68	
4	Village Gopisahi towards NE direction (Buffer zone)	46	

### 5.1.3 TANTRA Iron Ore Mines of M/S Korp Resources Pvt. Ltd.

Tantra iron ore mine is situated at Tantra of Sundargarh district. It has a production capacity of 0.12MTPA. The mine was inspected on 5<sup>th</sup> January 2015. The SPM and PM<sub>10</sub> concentrations at different locations were monitored. The result is shown in the table:

**Table 5.3:** Monitoring result of Tantra Iron Ore mine

Sl No	Locations	Parameters (µg/m <sup>3</sup> )	Standard
1	Tensa area (Buffer zone)	PM <sub>10</sub> = 51	100
2	Near crushing plant (25m from source)	SPM = 546	1200
3	Near active mining (25m from source)	SPM = 344	1200

The monitoring was carried out using Gravimetric method of sampling with Whatman glass fiber filter paper. It was found that the PM<sub>10</sub> and SPM concentrations were well within the limits.

## 5.2 PATMUNDA MANGANESE ORE MINE, OMML, SUNDARGARH, ODISHA

Patmunda manganese mine have a lease area of 807.316 hectares located in Bonai tehsil of Sundargarh district Odisha bounded by the latitudes 21<sup>o</sup>50'15"N to 21<sup>o</sup>53'07"N and longitudes 85<sup>o</sup>18'06"E to 85<sup>o</sup>20'05"E (as per the survey of India toposheet bearing number

73G/5 and 73G/1). It falls within six villages: kadamdihi, podadihi, patmunda, barpatholi, sanpatholi and sanarisibenua. The location map below shows the detailed location of the mine and the monitoring stations:

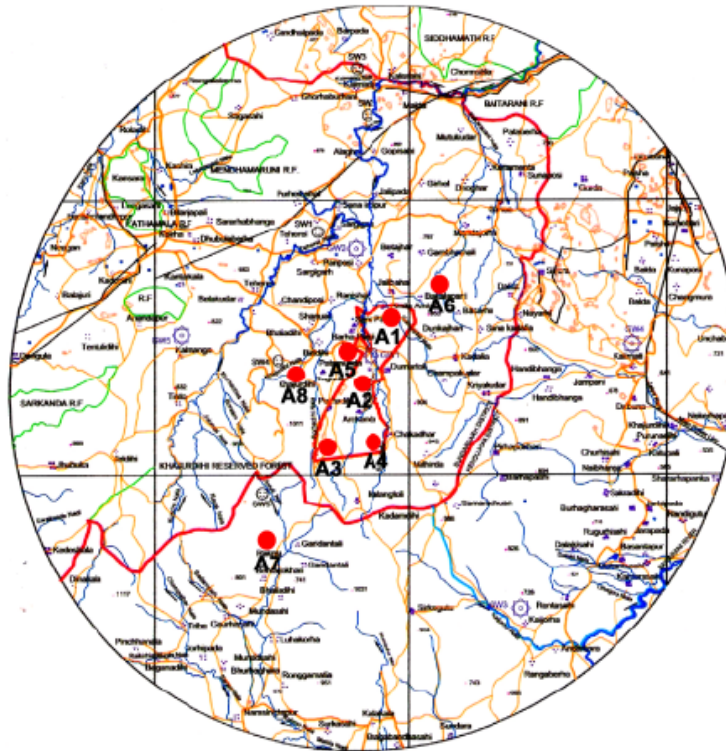

**Figure 5.1** the location map of study area.

**Scope of Study:** The study is limited to the selected zone of radius 10000 m<sup>2</sup> area around the mines. The mine has the total lease area of 525.926 hectares with an excavation of 108864m<sup>3</sup>/year and production of 253375 TPA Manganese Ore along with OB / Int. Wastes of 503282m<sup>3</sup> / Year.

The total detail about the mining area has been listed in table 5. The study is confined to three specific types of source of generation of particulate matters namely-

- Line Volume source
- Line Area Source
- Open Pit source

For the Line Volume Source and Line Area Source the maximum ground level concentration of the particulate matter generated due to dumpers on haul road is evaluated downwind and crosswind direction of the wind for the particular period. While in case of open pit source there are three constraints which are studied by varying it, viz Release Height, Pit Volume

(along with the length of pit in x and y direction) and Orientation Angle of the pit from the North. The variation in the above parameters leads to different sets of knowledge thereby giving important results so that we could design our production in such a way that leads to higher yield with less damage to the environment.

### **5.2.1 Methodology**

There were eight monitoring stations for air quality. Monitoring was carried out during September 2014 to November 2014 (post monsoon season), sampling stations were taken based on the factors like predominant wind direction, sensitive receptors, reserve location, topography etc. the Indian standards IS: 8829, IS: 5128 and emission regulations from central pollution control board (CPCB) were followed. Four sampling stations A1, A2, A3 and A4 are in mining lease area while A5 was located in Patmunda village (500 mt from ML). Two sampling stations were in pre dominant wind direction: one was within mining lease area and other in the buffer zone. The frequency of monitoring for ambient air quality was on 24 hourly basis twice a week for three months. The sampling was carried out using Respirable dust sampler of Envirotech Pvt. Ltd.

The highest PM<sub>10</sub> concentration was recorded at 87.4 µg/m<sup>3</sup> while SO<sub>2</sub> and NO<sub>x</sub> was found to 4.8 – 13.2 µg/m<sup>3</sup> and 7.1 – 21.0 µg/m<sup>3</sup> respectively which was within the norms of NAAQS and CPCB.

For the modelling analysis PM<sub>10</sub> was taken as the criteria pollutant. The period for baseline data collection was post monsoon of 2011. The micro meteorological data of the study period was very important for the interpretation of the baseline information and the as the input in modelling. The meteorological station was installed near the ML by the SUN consultancy and services at the site to record continuously the temperature, humidity, wind direction and cloud cover of the area in addition to that annual climatic data was collected from IMD Keonjhar, which is the nearest meteorological station to the project site. The following parameters were recorded continuously on hourly basis:

- Wind speed
- Wind direction
- Air temperature
- Relative humidity
- Rain fall

- Cloud cover

The mathematical modelling for the purpose of prediction of impacts on air quality is performed by AERMOD model, which is based on straight line steady state Gaussian Plume dispersion Model approved by USEPA and MoEF, govt of India.

The table below shows the meteorological data recorded for the modelling purpose this data is calculated to represent the hourly information:

**Table 5.4:** Sample Met data used for the modelling purpose

Days	Hr	Cloud Cover (tenths)	Dry Bulb Temp. (°C)	RH (%)	Station Pr. (mbar)	WD (deg)	WS (m/s)	Ceiling Height (m)	Hrly ppt. (1/100 th of Inch)	Global Horizontal Radiation (Wh/m <sup>2</sup> )
1	1	5	31	83	988	180	0.8	3000	0	0
1	2	5	30	80	988	135	3.7	3000	0	0
1	3	5	29	83	988	135	3.5	3000	0	0
1	4	5	30	80	988	270	0.7	3000	0	0
1	5	5	30	80	988	45	4.5	3000	0	0
1	6	5	29	81	988	0	0	3000	0	0
1	7	5	30	80	988	0	0	3000	0	5000
1	8	5	31	83	988	0	0	3000	0	5000
1	9	4	31	81	962	270	0.8	3000	0	5000
1	10	4	24	78	962	225	2.9	3000	0	5000
1	11	5	24	78	988	45	3.1	3000	0	5000
1	12	4	26	76	962	135	2.8	3000	0	5000
1	13	4	27	83	962	270	0.7	3000	0	5000
1	14	5	26	76	988	0	0	3000	0	5000
1	15	5	25	77	988	0	0	3000	0	5000
1	16	5	25	77	988	0	0	3000	0	5000
1	17	5	24	78	988	135	2.9	3000	0	5000
1	18	5	32	79	988	360	1	3000	0	0
1	#	4	32	80	962	225	1	3000	0	0
1	#	5	31	81	988	180	0.9	3000	0	0
1	#	4	31	81	962	270	0.8	3000	0	0
1	#	4	31	81	962	0	0	3000	0	0
1	#	5	31	82	988	0	0	3000	0	0
1	#	4	31	83	962	45	6.5	3000	0	0

This met information was converted to .Samson format from AERMET and is used by it to generate the WARPLOT which has the windrose plot and frequency distribution bar graph of wind class shown in the picture it also prepares two files: .SFC and .PFL for the AERMOD.

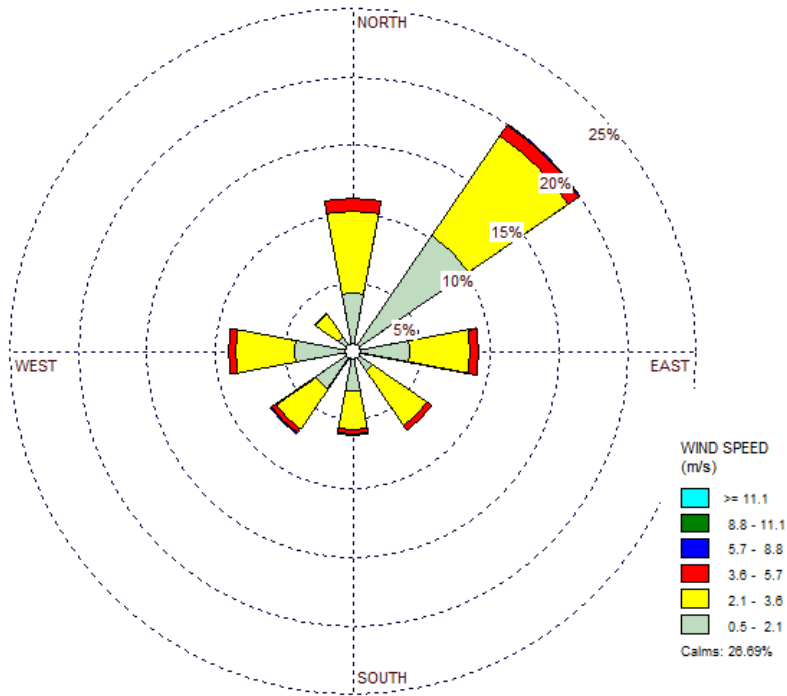

**Figure 5.2** Windrose diagram

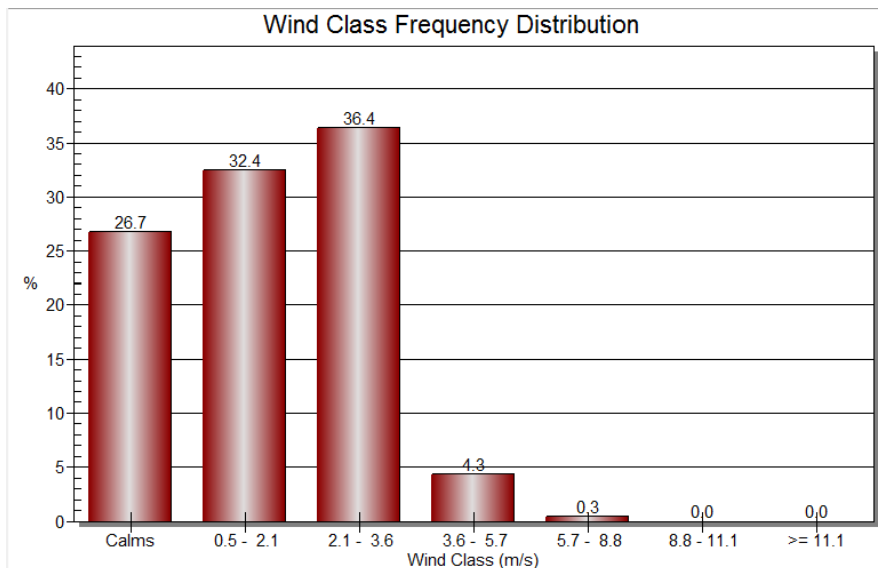

**Figure 5.3** Wind Class frequency distribution

The model needs the emission rates for the different sources in the present work the haul road empirical equation is used for the line source while open pit equation is considered for the volume source. With the same emission rate of open pit, open pit source type is also tried. For the emission rate calculation some mining data is required which is given in the table below:

**Table 5.5:** Input for Line source and Volume source modelling

Sl. No.	Description	Data	
		Line Source	Volume Source
1	Moisture Content = [m], (%)	18	10
2	Silt Content = [s], (%)	9	7
3	Wind Speed = [u]		
4	Exposed quarry Pit Surface Area = [a], m <sup>2</sup>	--	Q1 – 80000 Q2 – 150000 Q3 – 120000
5	Release Height = Working Depth, mtr.	--	30
6	Emission Rate = [E]		
7	Average Vehicle Speed m/sec.	5.6	--
8	Production	--	Mn Ore – 253375 TPA OB / mineral Wastes 503282m <sup>3</sup> /yr
9	Query pit area		
10	Dumping Area, Km <sup>2</sup>	--	Existing - 0.0424 Proposed-0.1817
11	Lease Area, ha.	--	525.926
12	Excavation	--	108864m <sup>3</sup> /yr
13	Transported Material	990 TPD	--
14	No. of Trips / day	66	--
15	No. of Trips / hour	8.22	--
16	Qty of Ore in each Trip	15 T	--
17	Road Width	8 - 10m	--
18	Road Length	1.0km	--
19	Capacity of dumpers in ton.	15 T	--

### 5.2.2 Calculation of Haul road emission rate:

According to the given empirical equation haul road emission rate depends on silt content, wind speed, average vehicle speed, frequency of the vehicle movement and capacity of the dumpers. The knowledge of these data can give the required haul road emission for line source modelling.

$$E = \left[ \left\{ \frac{(100 - m)}{m} \right\}^{0.7} \left\{ \frac{us}{(100 - s)} \right\}^{0.1} \{ (41.6 + 0.03fc + 108v) \} 10^{-5} \right] \text{----- (17)}$$

Where,



- E : Emission rate in g/s/m<sup>2</sup>
- m : Moisture content in road dust in % = 18
- u : Wind speed in m/s = 1.57
- s : Silt content in road dust in % = 9
- v : Average vehicle speed in m/s = 5.6
- f : Frequency of vehicle movement in no. /hr. = 8
- c : capacity of dumpers in ton = 15

From the above data the emission rate for the haul road is calculated as 0.01559561 g/s/m<sup>2</sup>

### 5.2.3 Calculation for open pit source:

The open pit source calculation gives the required emission rate for the volume source modelling. The associated equation requires the data such as moisture content, silt content, wind speed and area of the pit. The governing empirical equation is:

$$E = \left[ \left\{ \frac{(100-m)}{m} \right\}^{0.1} \left\{ \frac{s}{(100-s)} \right\}^{0.3} a^{1.6} \left\{ \frac{u}{(10+125u)} \right\} \right] \text{----- (18)}$$

Where,

- E : Emission rate in g/s/m<sup>2</sup>
- m : Moisture content of surface in % = 10
- s : Silt content of surface material in % = 9
- u : Wind speed in m/s = 1.57
- a : Area of pit in Km<sup>2</sup> = 0.35

From the above data the emission rate for the open pit mine is calculated as 0.000813623238929g/s/m<sup>2</sup> (for SPM) while it is 0.00048817394335783g/s/m<sup>2</sup> (for PM<sub>10</sub>).

The resultants GLCs of all Cartesian locations are given in table 5-6 and are well within the NAAQs norms.

**Table 5.6:** Fugitive dust concentrations at the sampling points

Location ID	Direction of mines	Distance from mines in Km	Fugitive Dust (in $\mu\text{g}/\text{m}^3$ )				Resultant conc.
			Background Conc.	Incremental Conc.(contribution due to proposed mines)			
				Volume Source Modelling	Line Source Modelling	Total Incremental Conc.	
A1	NE of ML Area	-	78.4	0.01118	0.00012	0.0113	78.4113
A2	Center of MI Area	-	87.1	0.01215	0.00011	0.01226	87.11226
A3	SW of ML Area	-	80.8	0.00122	0.00995	0.01117	80.81117
A4	SE of ML Area	-	86.2	0.00346	0.00021	0.00367	86.20367
A5	West of ML Area	-	64.2	0.08082	0.00030	0.08112	64.28112
A6	NNE of ML Area	3.0	54.7	0.00544	0.00020	0.00564	54.70564
A7	SSW of ML Area	6.1	62.9	0.00018	0.00009	0.00027	62.90027
A8	West of ML Area	2.2	58.4	0.01595	0.00038	0.01633	58.41633

The Line and Volume Source modelling yields the following isopleths (curves and lines drawn along the regions of same numeric values) of  $\text{PM}_{10}$  concentrations as shown in the Figure 5.4 and Figure 5.5 respectively.

From the different modelling options available the line, volume and open pit sources. The release height, orientation angle of the pit, and pit size are the three constraints which results in variation of the particulate matter generation in open pit case. While the selection of the haul road according to the Windrose depicts the particulate matter concentration level i.e if the haul road is selected along the wind direction there is high ground level concentration (GLC) whereas across it the GLC decreases. The different modelling options tried with varying the release height, orientation angle and pit size has been tabled with the maximum ground level concentrations at the source.

PROJECT TITLE:  
LINE SOURCE MODELLING

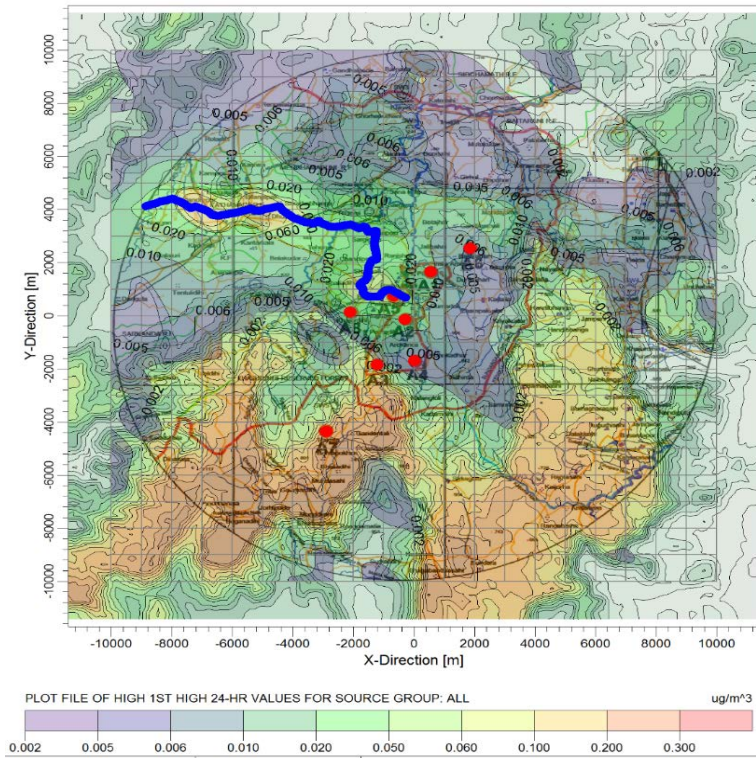

**Figure 5.4** Isopleths of Line Source Modelling (24 hr, max conc. = 0.25325 $\mu\text{g}/\text{m}^3$ )

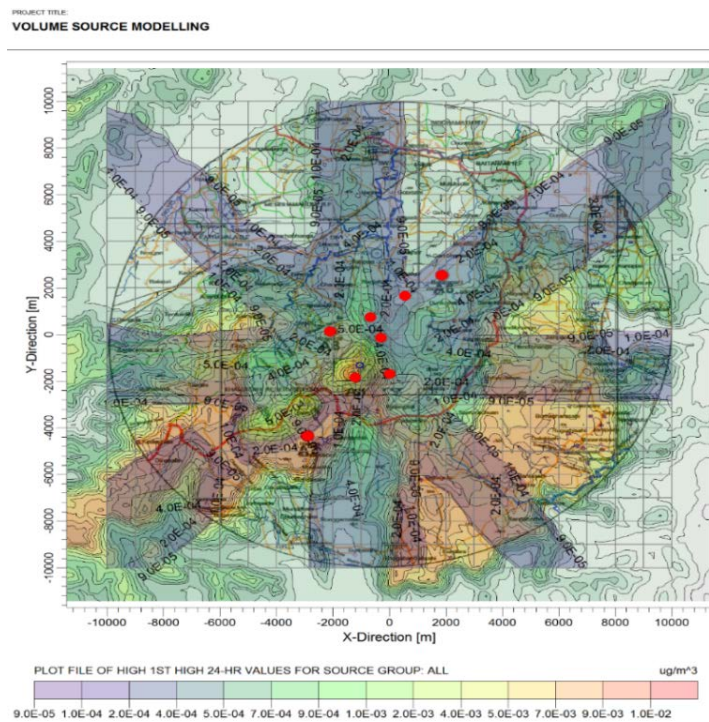

**Figure 5.5** Isopleths of Volume Source modelling (24 hr, max conc. = 0.00995 $\mu\text{g}/\text{m}^3$ )

**Table 5.7: Open pit modelling by varying pit size, orientation angle and release height**

SI No	Constraints	Length of pit on X-axis, L <sub>x</sub> (m)	Length of pit on Y-axis, L <sub>y</sub> (m)	Orientation Angle from North, $\theta$ (degrees)	Release Height (m)	Maximum ground Level Concentration at center (0,0), GLC <sub>max</sub> ( $\mu\text{g}/\text{m}^3$ )	Remarks
I	Keeping Pit size, orientation angle constant and varying release ht.	50	100	45	5.0	88.437622	
		50	100	45	10.0	100.051685	
		50	100	45	15.0	173.210463	
II	Keeping Pit size, Release ht. constant and varying orientation angle	50	100	45	15.0	173.210463	Approximate down wind direction.
		50	100	90	15.0	158.157065	
		50	100	135	15.0	121.395701	
III	Keeping Release ht. orientation angle constant and varying Pit size.	20	100	45	15.0	147.73703	Approximate down wind direction.
		100	20	45	15.0	131.07804	Cross wind direction.
		2	100	45	10.0	157.44356	Down wind direction.
		100	2	45	10.0	101.59756	Cross wind direction.

**Table 5.8: Line Volume source modelling according to Wind direction**

SI No	Haul Road Direction	Configuration	Plume Height (m)	Plume Width (m)	Emission Rate, (g/s)	Maximum Ground Level concentration, GLC <sub>max</sub> at (0,0), ( $\mu\text{g}/\text{m}^3$ )
I	Towards Downwind	Adjacent	6.8	9.0	0.000488	162.35681
II	Towards Crosswind	Adjacent	6.8	9.0	0.000488	107.65219

**Table 5.9: Line Area Source modelling according to Wind directions**

SI No	Haul Road Direction	Length of side, (m)	Initial Vertical Dimension, (m)	Ratio	Emission Rate, (g/s)	Maximum Ground Level concentration, GLC <sub>max</sub> , ( $\mu\text{g}/\text{m}^3$ )
I	Towards Downwind	9.0	3.16	1:10	0.00139	142.1153234
ii	Towards Crosswind	9.0	3.16	1:10	0.001392	135.7789765

The monitoring reports explains the emitted concentrations of particulate matters while the modelling gives the predicted concentration along with the three modelling options with varying the parameters that effects the particulate matter concentration.

### 5.3 Particulate matter characterization of Essel, Oraghat, Kalta, Tantra and Sanindpur Iron Ore Mines

The particulate matter characterization is essential in order to do both qualitative and quantitative analysis of particulate matters. In the present work Filter papers are cut in to pieces by stainless steel scissors and transferred in to beaker. Digestion is done with 6ml concentrated nitric acid and 4ml hydrogen peroxide and 50ml distilled water. This procedure is repeated twice until residue is dry and white ash appears. The residue is again dissolved with 5ml concentrated nitric acid and filtered with repeated small washing of nitric acid into 25ml volumetric flask and make up volume with dilute nitric acid. This is for one element. This clear extract is then taken for analysis in Atomic Absorption Spectrophotometer.

The particulate matter of size less than 10 microns i.e PM<sub>10</sub> from different Iron Ore Mines have been taken for the purpose of characterization. The table shows the presence of mineral matters in the dust particulates collected from different mines:

**Table 5.10:** The mineral constituents of particulate matter (PM<sub>10</sub>) in µg/m<sup>3</sup>

SL. No.	Locations	Fe	Mn	Na	K	Zn	Cu	Cr	Ni	Pb	As
1.	Essel Mining near water bodies	<0.2	<0.1	<0.2	<0.2	0.04	<0.1	<0.2	<5.0	<0.4	<1.0
2.	Kalta Iron Ore Mines near guest house	<0.2	<0.1	<0.2	22.4	0.08	<0.1	<0.2	<5.0	<0.4	<1.0
3.	Oraghat Iron and Manganese Mines near crusher	<0.2	<0.1	<0.2	<0.2	0.02	<0.1	<0.2	<5.0	<0.4	<1.0
4.	Tantra Iron Ore Mines near crusher	<0.2	<0.1	<0.2	<0.2	0.026	<0.1	<0.2	<5.0	<0.4	<1.0
5.	Sanindpur Iron and Bauxite Mines near water bodies	<0.2	<0.1	<0.2	<0.2	0.029	<0.1	<0.2	<5.0	<0.4	<1.0

## Chapter 6

### DISCUSSION AND CONCLUSION

#### 6.1 DISCUSSION

Since there is greater stress on improving production by open cast mining methods, we are moving towards larger scale mechanization. However some of the operations are potential source in generating larger quantity of particulate matter. If, appropriate preventive and control measures are not adapted then the concentration of particulate matter may reach alarming levels causing environmental and health hazards not only to the persons in mining but also to the local people residing in downwind side. There could be seen components in particulate matter which has greater potential to cause health hazards compare to others. It is therefore essential to carry out sampling of particulate matter and compare it with the standards prescribed by NAAQs.

#### **AIR Quality Monitoring**

The monitoring of different iron ore mines viz. Barsuan and Kalta, Tantra and Oraghat mines revealed that the emission of SPM and PM<sub>10</sub> were well within the NAAQs and SPCB guidelines.

#### **Modeling**

The modelling of Patmunda Manganese ore mine reveals that the maximum ground level concentration (GLC) of PM<sub>10</sub> due to line Source emission would be 0.25325  $\mu\text{g}/\text{m}^3$  which will be experienced at a distance of 7.5 Km W-NW from the center of the mine lease area. The maximum GLC of PM<sub>10</sub> 0.00995  $\mu\text{g}/\text{m}^3$  due to volume source emission (from exposed area of the mine pits) would be experienced at a distance of 2.0 Km SW of the center of the mine lease area. The experimented modelling options showed that if the release height and pit volume is decreased and the pit orientation is kept across the wind the emission concentration reduces.

The modelling of particulate matter dispersion is essential to find out the potential locations where the particulate matter concentration could be higher. This will help in adapting appropriate control strategies. Keeping this in mind samples were collected from Barsuan and Kalta, Tantra and Oraghat iron ore mines. Characterization from a few is carried out to find

the mineral compositions of the particulate matters. Modelling of Patmunda manganese ore mine is carried out as the case study.

The study reveals that the modelling options from the source pathway provides different types of sources of Particulate matter generation and thereby gives maximum particulate concentration at a point from the emitted one.

While considering the **open pit** source type of Particulate matter generation the three main constraints are observed they are: Pit size, orientation angle of the pit from the North and release height. Taking each one to be a variable at a time and the other two constant gives interesting findings. Like keeping the pit size, orientation angle of the pit constant and varying/increasing the release height of the emission gradually, shows the increase in maximum ground level concentration. Likewise keeping pit size, release height constant and varying the orientation angle of the pit from north along the downwind direction and along the crosswind clearly indicates that the maximum ground level concentration reduces as the pit moves from the downwind towards the crosswind. Whereas when the release height, orientation angle are kept constant and pit size is varied, two conclusions can be drawn in this regard: i) lesser is the pit volume lesser is the maximum ground level concentration and ii) As the pit length increases in the direction of the downwind the maximum ground level concentration increases while when the pit length moves towards the crosswind direction the maximum concentration decreases.

Out of the other source types available with the AERMOD, **Line volume source** is the one in which AERMOD handles the line sources as the series of the volume sources. AERMOD View can automatically generate these volume sources to represent the line source that is specified. Examples of line sources include haul roads, conveyor belts, rail lines, etc. primarily it is the number of volume sources that is generated to represent the line segments. Here when the haul road is taken in the direction of the downwind the maximum ground level concentration increases while the same gets significantly reduced when the haul road is taken across it.

Line area source is one more source type available with AERMOD. The **Line Area Source** tool is an option specific to AERMOD View which allows us to define a series of area sources to represent a line. The same trend is observed here as in line volume sources.

Air quality modeling has been done using AERMOD. Line source & Volume source modeling were carried out for haul road and open pit respectively. Wind rose and stability

class diagram for the area for the monitoring period has been generated. From the modeling exercise, Particulate matter concentrations at certain receptor locations have been predicted and it was found that the resultant SPM level at these locations will remain within the NAAQS norms. With use of meteorological data, Particulate matter concentration data and emission data, isopleths for mining area could be generated using AERMOD. AERMOD could be used not only for existing mines but for also proposed mines. It can predict Particulate matter concentrations and accordingly measures for its control could be adopted.

### **Characterization**

The characterization of the particulate matter (PM<sub>10</sub>) from Essel iron ore mines, Kalta iron ore mines, Oraghat iron and manganese ore mines, Tantra iron ore mines and Sanindpur iron and bauxite ore mines shows the presence of Nickel and Lead present in the dust particulates in all of them. Moreover the particulate matter of Kalta iron ore mine has higher concentration of Potassium and zinc in it as compared to others. The presence of Arsenic is observed in each of the mine dusts in though in small proportions. The other minerals such as Iron, Manganese, Sodium, Copper and chromium too have their presence though were in proportionately meager quantities.

#### **6.1.1 Practical Applications**

The above findings leads us to the situations that needed to be considered while any mining project is planned. The wind and other meteorological conditions are important parameters that has significant impact on environment since particulates generated through different mining operations has got carriers and thus a potential threat to the air quality of the areas. These meteorological conditions are mostly or say predominantly associated with the seasons and hence our actions should also be accordingly. The air quality modelling gives us some of the important results which must be our bases while planning for the mining operation. Some of them are:

- **Seasonal pit excavations:** As been seen from the modelling that the wind direction along with its speed and other meteorological conditions, the pit when excavated in the crosswind direction yields lesser ground level concentrations. But since these parameters are season dependent thus this should be planned accordingly
- **Season-wise vehicle movement:** From the line volume source and line area source we have seen that if the haul road is across the downwind direction there is lesser



particulates being liberated to far flung areas and at the same time this is seasonal as wind changes its directions and so be our haul road usage too.

- **Dump management:** The over burden dumping is a critical operation generating large Particulate matter deposition into the environment. These OB dumps should be managed by taking into consideration that in which season the dump should be started how the slope should, be since slope failure is one of the most unpredictable and fatal scenario in mining industry.

The characterization is the detailed analysis of the particulate matter. There should be proper method for the dust segregation the combustion was tried out followed with SEM which yielded higher silica and oxygen percentages due to presence of glass in the filter paper. Thus it is equally important to choose the method with less error. There were 10 different elemental concentrations were analyzed but a dust particulate may have a number of other elements present, so in depth analysis requires more precise and thorough study of the samples.

## 6.2 CONCLUSION

The monitoring of air quality which is done by sampling at some of the iron and manganese ore mines shows that the ambient concentrations of particulate matters were well within the limits as prescribed by NAAQs. Some of the sampling points such as near haul roads, crusher area and active mining areas had recorded higher concentrations though were within the limits but needed to be taken care of. There should be greater stress on frequent sampling and efficient dust suppression techniques such as sprinklers and plantations must be implemented as a preventive measure. Black topping of major haul road and regular cleaning of haul road will reduce the particulate matter towards substantial extent. Maintaining the green belt by planting trees having a thick foliage on both side of the haul road will help in arresting the particulate matter travelling outwards. Spillage of material by transporting vehicle should also be avoided. Putting a cover at the material delivery point and making water sprinkling arrangement will help in controlling the particulate matter from getting airborne. The operation that causes the particulate matter emission from mining area are drilling and blasting. Using drilling machines with more thrust and less rotation reduces the generation of particulate matter. Wet drilling is another method that is being practiced increasingly to control dust, however it has the demerit of reducing the rate of penetration. For increased production, dry drilling is practiced these days. Modern drilling machines used for dry

drilling are now available with dust hoods and extractors. This should be used to maintain a particulate matter free environment around the drilling site. Blasting is usually carried out in between two sheets where very less number of people are present in the mines, however the blast generated particulate matter has the tendency to travel far off from the mine in the prevalent wind direction. The strata, where blasting is to be carried out may be wetted prior to blasting to control the generation of particulate matter. Water spray arrangement may be activated immediately after blasting to suppress the dust from getting airborne. Fog cannons are now available which may be located at the pit top and could be directed to the blasting site immediately after blasting is done to control the dust from getting airborne.

The modelling was attempted using USEPA model known as AERMOD. Line source, Volume source and open pit modelling has been tried for haul roads and open pit areas. From the hourly met data the surface and profile file along with the Windrose and wind class frequency distribution chart has been generated from AERMET preprocessor. The terrain data is preprocessed using AERMAP. The particulate matter concentrations at different sampling locations and emission rates from mining data were used to predict the particulate matter concentrations at the specified receptor locations. The isopleths and predicted concentrations shows that it will remain under the prescribed limits of NAAQs. From different modelling options it can be concluded that the pit designing if could be seasonal then the emission could further be reduced significantly.

The characterization shows the elemental concentrations in the particulates. The presence were not at the alarming levels but could atmost cause the nuisance if being subjected to the exposure for the longer durations. There were some elemental concentrations available which needs to be taken care of. The harmful elements such as nickel, lead and arsenic have registered their presence in the particulate matters which is unlikely and needed to be dealt with some effective control methodologies. The traces of other elements such as Iron, Manganese, Sodium, Pottasium, Copper, Chromium too were found though were well below the prescribed limits.

### **6.3 LIMITATIONS AND SCOPE OF STUDY**

There are some suggestions which could lead to the easy and comprehensive analysis of air quality around a mine. They are:

- In India the hourly meteorological data is not monitored which is the primary requirement for modelling. The met stations should record hourly met data so that better assessment on air could be carried out.
- The better environmental and health effects of particulate matters can be evaluated if it can be categorized further such as 1-2.5 microns, 4-5 microns, 5-10 microns etc.
- Proper real time Particulate matter monitoring for all the potential particulate generating sources from every mining activities if could be devised than it will easier to check and implement the control measures.
- It would have been much better if we can use advanced methods of mineral extractions such as acid leaching and other such methods so that there will be lesser scope of particulate matter emission.

## Chapter 7

### REFERENCES

- Anastasiadou, K., and, Gidarakos, E., 2006, Toxicity evaluation for the broad area of the asbestos mine of northern Greece, *Journal of Hazardous Materials*, Vol. A139, pp: 9–18.
- Avie, M., William, T., Jerry, W, Jr., 1999, Compendium of methods for the determination of inorganic compounds in ambient air, Center for Environmental Research Information Office of Research and Development, USEPA, <http://www.epa.gov/ttnamti1/files/ambient/inorganic/mthd-3-1.pdf>, Accessed on April 20, 2015.
- Banerjee, G.K., Srivastava, K.K and Chakraborty, M.K., 2001, SPM is the major pollution in open cast mining – a case study, *Journal of Scientific and Industrial Research*, Vol. 60, pp: 416-420.
- Banerjee, K.K., Wang, H., Pisaniello, D., 2006, Iron-ore dust and its health impacts, *Environmental Health* Vol. 6 (1), pp: 11-16.
- Chakraborty, M.K., Ahmad, M., Singh, R.S., Pal, D., Bandopadhyay, C. & Chaulya, S.K., 2002, Determination of the emission rate from various opencast mining operations, *Environmental Modelling & Software*, Vol. 17, pp: 467–480.
- Chaulya, S.K., 1999, Air quality status of an open pit mining area in India, *Environmental Monitoring and Assessment*, Vol. 105, pp: 369–389
- Crocker, B. B., 1991, Air pollution control methods. *Kirk-Othmer Encyclopedia of Chemical Technology*.
- Dudka, S., and Adriano, D. C., 1997, Environmental impacts of metal ore mining and processing: a review, *Journal of Environmental Quality*, Vol. 26(3), pp: 590-602.
- EPA, 1995, User's guide for the industrial source complex (ISC3) dispersion models. Vol. I. Research Triangle Park, NC: U.S. Environmental Protection Agency, Office of Air Quality Planning and Standards, Emissions, Monitoring, and Analysis Division, EPA publication No. EPA-454/B-95-003.
- Ghose, M.K. and Majee, S.R., 2001, Air pollution caused by opencast mining and its abatement measures in India, *Journal of Environmental Management*, Vol. 63, pp: 193– 202.
- Holmes, N. S. and Morawska, L., 2006, "A review of dispersion modelling and its application to the dispersion of particles: an overview of different dispersion models available." *Atmospheric Environment*, Vol. 40(30), pp: 5902-5928.
- IS (Indian Standard) – 5182 (Part 23), 2006, Methods for measurement of air pollution part 23 respirable suspended particulate matter (PM<sub>10</sub>), cyclonic flow technique, 2006,
- Jaiprakash., Singh, G., Pal, A.K., 2010, Air Dispersion Modelling Performance for Mining Complex, *Environment and We An International Journal of Science and Technology*, Vol. 5, pp: 205-222.

- Kumari, S., Kumar, R., Mishra, K.K., Pandey, J.K., Udaybandhu, G.N. & Bandopadhyay, A.K., 2011, Determination of quartz and its abundance in respirable airborne dust in both coal and metal mines in India, *Procedia Engineering*, Vol. 26, pp: 1810-1819.
- MRI, 2015, Characterization Techniques, X-Ray Diffraction, The Pennsylvania State University- Material Characterization Laboratory, <http://www.mri.psu.edu/facilities/mcl/capabilities/characterization-techniques/xrd.asp>
- NIOSH, 1978, Occupational Health Guidelines for Manganese, <http://www.cdc.gov/niosh/docs/81-123/pdfs/0379.pdf>, Accessed on March 5, 2015
- Pereira, M, J., Soares, A., Branquinho, C., 1997, Stochastic simulation of fugitive dust emissions. In: Baafi EY, Schofield NA, eds. Wollongong '96, Fifth International Geostatistics Congress. Dordrecht, Netherlands: Kluwer Academic Publishers, Vol. 2, pp: 1055–1065.
- Roy, S., Adhikari, G.R., Singh, T, N., 2010, Development of emission factors for quantification of blasting dust at surface coal mines, *Journal of Environmental Protection*, 2010, Vol. 1, pp: 346-361.
- Sharma, A.K. and Siddiqui, K.A., 2010, Assessment of air quality for an open cast coal mining area, *Indian Journal of Scientific and Industrial Research*, Vol. 1 (2), pp: 47-55.
- Stuart, B. 2005, Infrared spectroscopy, Wiley Online Library, <http://onlinelibrary.wiley.com>, Accessed on May 19, 2015.
- Trivedi, R. , Chakraborty , M.K., 2008, Dust generation and its dispersion due to mining activities in Durgapur open cast coal project of W.C.L. - A Case Study, *The Indian Mining & Engineering Journal*, February, pp: 24–31.
- Turner, D, B., 1994, Workbook of Atmospheric Dispersion Estimates An Introduction to Dispersion Modeling, Lewis publishing, pp:2-4
- Vardoulakis, S., Fisher, B.E.A., Pericleous, k., 2003, Modelling air quality in street canyons: a review, *Atmospheric Environment*, Vol. 37 (2), pp: 155-182.
- Veranth, J, M., Smith, K, R., Aust, A, E., Dansie, S, L., Griffin, J, B., Hu, A, A., Huggins, M, L., Lighty, J, A, S., 2000, Coal fly ash and mineral dust for toxicology and particle characterization studies: equipment and methods for PM<sub>2.5</sub> and PM<sub>1</sub>- enriched samples, *Aerosol Science and Technology*, Vol. 32 (2), pp: 127-141.
- [www.weblakes.com/](http://www.weblakes.com/), Accessed on March 1, 2015
- <http://www.envirotechindia.com>, Accessed on February 11, 2015
- [www.allaboutfeed.net](http://www.allaboutfeed.net), Accessed on February 20, 2015
- [http://atmosphericdispersion.wikia.com/wiki/File:Gaussian\\_Plume.png](http://atmosphericdispersion.wikia.com/wiki/File:Gaussian_Plume.png), April 20, 2015