

Spectrum Sensing in Cognitive Radio

*A Thesis submitted in partial fulfillment
of the Requirements for the degree of*

Master of Technology
in
Electronics and Communication Engineering
Specialization: Communication and Networks

By
Naresh G
Roll No: 213EC5248



Department of Electronics and Communication Engineering
National Institute of Technology Rourkela
Rourkela, Odisha, 769 008, India
June 2015

Spectrum Sensing in Cognitive Radio

*A Thesis submitted in partial fulfillment
of the Requirements for the degree of*

Master of Technology

in

Electronics and Communication Engineering

Specialization: Communication and Networks

By

Naresh G

Roll No: 213EC5248

Under the guidance of

Prof. S.M.Hiremath



Department of Electronics and Communication Engineering
National Institute of Technology Rourkela
Rourkela, Odisha, 769 008, India
June 2015

Dedicated to my Parents, Guide and well-wishers...



Dept of Electronics and Communication Engineering
National Institute of Technology Rourkela
Rourkela-769 008, Odisha, India.

Certificate

This is to certify that the work in the thesis entitled **Spectrum Sensing in Cognitive Radio** by **Naresh G** is a record of an original research work carried out by him during 2014 - 2015 under my supervision and guidance in partial fulfillment of the requirements for the award of the degree of Master of Technology in Electronics and Communication Engineering (Communication and Networks), National Institute of Technology, Rourkela. Neither this thesis nor any part of it, to the best of my knowledge, has been submitted for any degree or academic award elsewhere.

Place: NIT Rourkela
Date: 27th May 2015

Prof. S.M.Hiremath
Assistant Professor



Dept of Electronics and Communication Engineering
National Institute of Technology Rourkela
Rourkela-769 008, Odisha, India.

Declaration

I certify that

- a) The work contained in the thesis is original and has been done by myself under the general supervision of my supervisor.
- b) The work has not been submitted to any other Institute for any degree or diploma.
- c) I have followed the guidelines provided by the Institute in writing the thesis.
- d) Whenever I have used materials (data, theoretical analysis, and text) from other sources, I have given due credit to them by citing them in the text of the thesis and giving their details in the references.
- e) Whenever I have quoted written materials from other sources, I have put them under quotation marks and given due credit to the sources by citing them and giving required details in the references.

Naresh G
27th May 2015

Acknowledgments

With deep regards and profound respect, I avail this opportunity to express my deep sense of gratitude and indebtedness to Prof. S.M.Hiremath, Department of Electronics and Communication Engineering, NIT Rourkela for his valuable guidance and support. I am deeply indebted for the valuable discussions at each phase of the project. I consider it my good fortune to have got an opportunity to work with such a wonderful person.

Sincere thanks to Prof. S.K.Patra, Prof. S.K.Behera, Prof. S.Deshmukh, Prof. K.K.Mahapatra, Prof. S.Meher, Prof. Samit Ari, Prof. A.K.Sahoo, Prof. S.K.Das, and Prof. S.Maiti for teaching me and for their constant feedbacks and encouragements. I would like to thank all faculty members and staff of the Department of Electronics and Communication Engineering, NIT Rourkela for their generous help.

I would like to make a special mention of the selfless support and guidance I received from my senior Varun, Department of Electronics and Communication Engineering, NIT Rourkela during my project work. Also I would like to thank Manas, Chithra, Satyendra and Venkatesh for making my hours of work in the laboratory enjoyable with their endless companionship and help. Last but not least I also convey my deepest gratitude to my parents and family for whose faith, patience and teaching had always inspired me to walk upright in my life.

Finally, I humbly bow my head with utmost gratitude before the God Almighty who always showed me a path to go and without whom I could not have done any of these.

Naresh G
gnaresh.nitr@gmail.com

Abstract

In modern wireless communications the spectrum is allocated to fixed licensed users and on the other side the number of wireless devices are increasing rapidly, that has lead to spectrum crunch. As the spectrum is precious it has to be utilized efficiently. The solution to mitigate this problem is Spectrum Sharing. One of the innovative approach to recognize and access the spectrum holes present in the licensed spectrum is Cognitive Radio (CR).

Spectrum sensing is a base for the performance of all functions performed by the Cognitive Radio (CR). Cognitive radio recognizes the unused spectrum and shares it to secondary users (SUs) without creating harmful interference to primary users (E.g. Cellular Networks, TV).

Literature discusses various SS techniques like ED, CSD, CMME with their advantages and disadvantages. ED is most preferred in CR because of simple implementation and semi-blind nature. But its performance is very poor at low SNR bound. So other combined techniques are preferred over the ED to enhance sensitivity of CR. So, thesis proposes Two Stage Spectrum Sensing as preferred in IEEE 802.22 standard. Combination of both ED and CMME method to enhance accuracy and timing of sensing in coarse and fine sensing stage respectively, is proposed and compared with individual sensing techniques. As the type of sensing takes place in two-level, the weak primary signals present in the spectrum are easily detected. If the signal is not identified in the first stage, it will be sensed in the second stage even if it is not detected, it can be declared as the absence of PU in the spectrum.

In this thesis, the performance of Single user and Global decision using Modified Deflection Coefficient (MDC) method is observed. Extensive study of cooperative SS and optimal cooperative sensing is done and results are presented.

Contents

Acknowledgement	v
Abstract	vi
Contents	vii
List of Figures	xii
List of Tables	xiii
1 Introduction	1
1.1 Background	1
1.2 Cognitive Radio (CR)	1
1.2.1 Functions of cognitive radio [1]:	2
1.2.2 TV White Spaces (TVWS):	2
1.2.3 Roles of Cognitive Radio (CR) [1] [2]:	3
1.2.4 Software Defined Radios (SDRs)	4
1.3 Literature Survey	5
1.4 Motivation	5
1.5 Objective of the work	6
1.6 Thesis format	6
2 Spectrum Sensing Techniques	8
2.1 Energy Detection Technique	8
2.1.1 Comparison of energy detection technique (ED) under Rayleigh channel along with AWGN and AWGN:	11
2.2 Cyclostationary detection technique:	15

2.3	Combination of Maximum Minimum Eigen value based detection technique:	19
2.4	Comparison of ED, CSD and CMME techniques	22
3	Two Stage Spectrum Sensing using ED and CMME	24
3.1	Two Stage Spectrum Sensing Scheme	25
3.2	Mathematical Analysis	25
3.3	Observation	27
4	Cooperative Spectrum Sensing	31
4.1	Diversity techniques:	34
4.1.1	Equal Gain Combining (EGC)	34
4.1.2	Maximal Ratio Combining (MRC)	36
4.2	Optimal Cooperative Spectrum Sensing	37
4.2.1	Local Sensing	39
4.2.2	Global Decision	40
5	Conclusion	45
5.1	Conclusion	45
5.2	Scope of Future work	46
	Bibliography	47
	Publication	52

Abbreviations

A/D	Analog to Digital Converter
AP	Access Point
AWGN	Additive White Gaussian Noise
BPSK	Binary Phase Shift Keying
BS	Base Station
CMME	Combination of Max-Min Eigen value detection technique
CR	Cognitive Radio
CSD	Cyclostationary detection technique
D/A	Digital to Analog Converter
DARPA	Defense Advanced Research Projects Agency
DVB-T	Digital Video Broadcasting Terrestrial
ED	Energy detection technique
EGC	Equal Gain Combining
FCC	Federal Communications Commission
GPS	Global Positioning System
IDEA	Infeasibility Driven Evolutionary Algorithm
LOS	Line-of-Sight
MDC	Modified Deflection Coefficient
MF	Matched Filter
MRC	Maximal Ratio Combining
NLOS	Non-Line-of-Sight
OFDM	Orthogonal Frequency Division Multiplexing
PSD	Power Spectral Density
PSO	Particle Swarm Optimization
PU's	Primary Users
RF	Radio Frequency

ROC	Receiver Operating Characteristics
SBI	Spectrum Bridge, Inc.
SDR	Software Defined Radio
SNR	Signal-to-Noise Ratio
SS	Spectrum Sensing
SU's	Secondary Users
TVBD	Television Band Devices
TVWS	Television White Spaces
UHF	Ultra High Frequency
VHF	Very High Frequency
WS	White Space

Nomenclature

T_x	Transmitter
R_x	Receiver
P_d	Probability of detection
P_{md}	Probability of misdetection
P_f	Probability of false-alarm
τ	Sensing time
f_s	Sampling frequency
σ_s^2	Signal power
σ_w^2	Noise power
Φ_{ED}	Threshold in Energy detection technique
$Q(\cdot)$	Q-function
$\Gamma(\cdot)$	Γ -function
$\mu_x(k)$	Mean of $x(k)$
$R_x^\alpha(K)$	Cyclic auto-correlation function of $x(k)$
α	Cyclic frequency
\widehat{C}_v	Covariance matrix of \widehat{R}_x
R_x	Covariance matrix of $x(k)$
λ_{max}	Maximum Eigen value
λ_{min}	Minimum Eigen value
γ_2	Threshold in CMME technique
β	false alarm rate constraint
$F_1(\cdot)$	Tracy-widom distribution function

List of Figures

1.1	White Spaces Network [3]	3
2.1	Spectrum Sensing techniques [4]	9
2.2	Energy Detector block diagram [5]	10
2.3	P_d vs SNR	12
2.4	P_d vs P_f	13
2.5	Spectrum Sensing in Rayleigh channel along with AWGN	14
2.6	P_d vs P_f	14
2.7	Cyclostationary detection technique	18
2.8	Combination of Maximum Minimum Eigen value based detection technique	22
2.9	Comparison of ED, CSD and CMME techniques	23
3.1	Two-stage spectrum sensing technique (ED and CMME detection technique)	25
3.2	P_d vs SNR by taking BPSK as input signal (N=100)	27
3.3	P_d vs SNR by taking BPSK as input signal (N=1000)	28
3.4	γ_2 vs P_d	28
3.5	P_d vs SNR by taking DVB-T as input signal	29
3.6	Comparison of Spectrum Sensing techniques	29
4.1	P_f vs P_{md} by varying the no. of receive antennas	35
4.2	P_f vs P_{md} by varying the no. of receive antennas	37
4.3	Schematic representation of weighting cooper. for SS in CR net- works [6]	38
4.4	P_f vs P_{md}	43
4.5	P_f vs P_{md}	44

List of Tables

3.1	Comparison of Prob. of detection P_d of spec.sen. tech's with SNR	30
-----	---	----

1

Introduction

1.1 Background

As the bandwidth of frequency spectrum employed in modern wireless communication systems is fixed and on the other side the number of wireless devices are increasing rapidly. To overcome the spectrum scarcity, the unused frequency bands are accessed by secondary users (SU's) without interfering with primary users (PUs). These unused licensed frequency bands of primary users (PUs) or primary systems technically known as white spaces or spectrum holes. The only innovative approach to access these white spaces without creating any interference to the primary users (PUs) is cognitive radio (CR). While coordinating to access the frequency channel, the transmitting parameters should be changed in order to overcome the interference with the PUs. Spectrum sensing (SS) is the important task to enable dynamic spectrum access without interfering with PUs.

1.2 Cognitive Radio (CR)

Cognitive radio (CR) is an intelligent radio of wireless communication in which a transceiver identifies which communication channels are busy and which are free, and immediately move into empty channels while avoiding occupied frequency channels [7]. This optimizes the utilization of available radio frequency (RF) spectrum while mitigating the interference to other PUs by identifying and utilizing only the white spaces [1].

CR is a modern technology that is developed on SDR platform.

1.2.1 Functions of cognitive radio [1]:

- The ability of a transceiver to decide its geographic location.
- Identify and authorize its user.
- Encrypt or decrypt signals.
- Sense adjacent wireless devices in operation and
- Adjusts output power and modulation characteristics.

There are two categories of cognitive radio (CR). They are [1]:

a) Full cognitive radio:

Full CR considers all parameters that a wireless network or node can be aware of.

b) Spectrum sensing cognitive radio:

Spectrum sensing CR is used to identify channels in the radio frequency (RF) spectrum. There is a provision for accessing the unutilized parts of the Radio Frequency (RF) spectrum for public use as per the decision made by the Federal Communications Commission (FCC). There is a requirement of white space devices which should contain advanced technologies to block interference. The proposal for CR was enhanced by J.Mitola at the DARPA in US. Full CR can be called as "Mitola radio."

1.2.2 TV White Spaces (TVWS):

Television White Spaces (TVWS) can be defined as, the frequencies which are made accessible for unlicensed utilization at the places where licensed users are not using the spectrum such as TV broadcasting [3], [8].

- Capability to cover a more prominent range at a relatively less cost.
- RF signals has a capability of penetrating through the obstacles in Non-line-of-sight propagation.

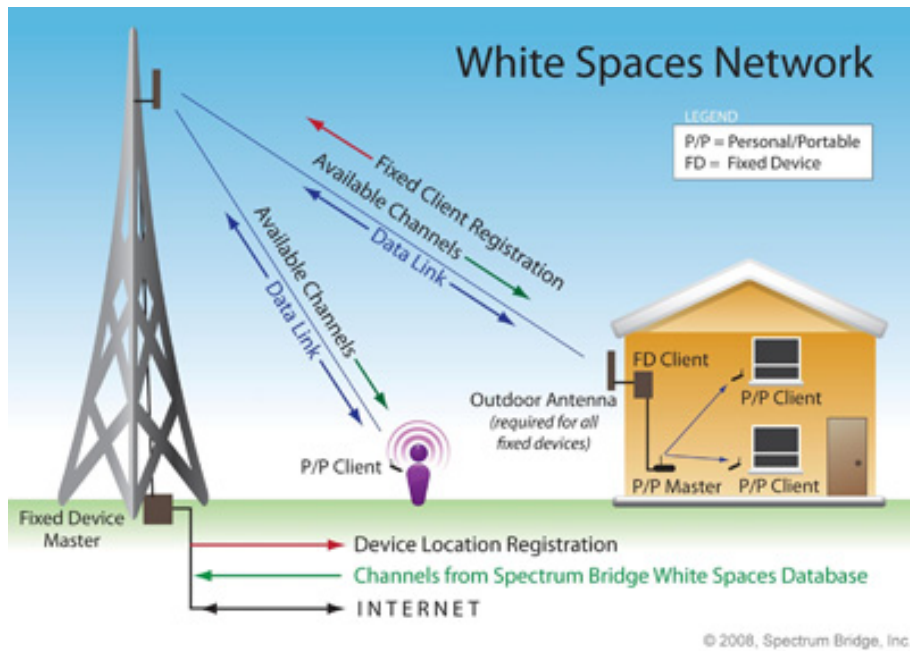

Figure 1.1: White Spaces Network [3]

1.2.3 Roles of Cognitive Radio (CR) [1] [2]:

The main roles performed by Cognitive Radio (CR) are [2]:

a) Spectrum Sensing (SS):

The role of SS is to recognize the unused spectrum and shares it to the secondary users (SU's) without creating any harmful interference with other licensed users i.e., primary users (PU's) (e.g. Television (TV), Cellular Networks).

b) Spectrum Management:

The role of spectrum management is to select the available spectrum and allocating it to user for better communication.

c) Spectrum Mobility:

In this process exchange of frequency of operation by CR user takes place.

d) Spectrum Sharing:

Spectrum sharing determines the secondary user (SU) that can utilize the white space (i.e., spectrum hole) at some particular time.

1.2.4 Software Defined Radios (SDRs)

A software-defined radio (SDR) is a wireless communication system. The functionality of the SDR can be configured using software or programmable hardware. Conventional radio transmitters (T_x) and receivers (R_x) can usually send and receive a signal of single type. SDRs are more adaptable. Using different software configurations, software-defined radio (SDR) hardware can communicate at different frequencies using multiple wireless standards such as Global Positioning System (GPS), Wi-Fi, FM Radio, Bluetooth and LTE technology [1].

A software-defined radio (SDR) has a special portion of the system defined in software and it has several advantages:

- Ease of advancement
- Flexibility in reconfiguration and
- Cost adequacy

SDRs normally comprise of a RF front end (transmitter or receiver) with an A/D (analog to digital) or D/A (digital to analog) converter. A general purpose PC or reconfigurable hardware (e.g., FPGA) is utilized with the SDR for baseband signal processing [1].

Development Workflow:

An optimal work process for developing software-defined radios (SDRs) involves designing and verifying the system in a single progress environment. Software-defined radio (SDR) hardware can be incorporated into your design in two ways:

a) Input and Output (I/O):

Connect and configure the software-defined radio (SDR) hardware to send and receive present radio signals using the transmitter (T_x) and receiver (R_x) terminals on the radio. These signals are processed to the host, for quick prototyping of the transmitter (T_x) and receiver (T_x) algorithms.

b) Target:

Deploy the code onto the FPGA or software-defined radio (SDR) hardware platform. The FPGA is programmed with the precompiled bitstream file or generate HDL code from the design, compile the code and program the FPGA.

1.3 Literature Survey

Spectrum Sensing (SS) is the significant task performed by CR which helps in identifying the unused spectrum and is allocated to secondary users (SUs) without disturbing the primary users (PUs). The overview of various sensing schemes and their performance, applicability and effectiveness under various transmission conditions and advantages and disadvantages with each sensing technique is explained in [4]. In [2] presents an overview of SS techniques.

In [5] explains the significance of spectrum sensing schemes and used energy detection technique to show that the formulated problem indeed has one optimal sensing time which obtain the highest throughput of the secondary network. In [9] explains the significance of the cyclostationary detection technique, which is used in fine sensing stage. In ([10], [11]) proposed that the eigen-value detection technique avoids the effect of noise uncertainty and it has a better probability of detection compared with the energy detection in both AWGN and fading channels.

In [12] the comparison between energy detection and cyclostationary detection technique is explained with respect to Receiver Operating Characteristics (ROC) by considering BPSK, BFSK and GMSK channels for application in Cognitive Radio (CR).

In [13], the performance of cooperative SS and optimal soft combination algorithm to enhance the detection probability was proposed. In [14], cooperative SS when two SU's collaborate via the relaying scheme was proposed.

1.4 Motivation

According to current scenario the spectrum is allocated to fixed licensed users or PUs. It leads to underutilization of the spectrum, the unused spectrum (white space) can be allocated to secondary users (SUs) without creating any harmful interference to the PUs. Spectrum sensing (SS) plays an important role in identifying the presence of white spaces performed by Cognitive Radio (CR).

After observing the individual performance of spectrum sensing techniques like energy detection, cyclostationary detection and eigen-value detection technique. The advantages of two stage SS technique w.r.to individual techniques motivated

to implement Two stage SS technique using ED and CMME. As suggested in IEEE 802.22 standard for CR, novel two stage spectrum sensing based on energy detection as coarse sensing first stage and combination of maximum-minimum eigen value based detection technique (CMME) as fine sensing second stage is proposed which enhances the accuracy, sensitivity and timing.

1.5 Objective of the work

The objective of the research work is summarized as follows :

- To compare the individual techniques in spectrum sensing like energy detection (ED), Cyclostationary detection (CSD) and combination of maximum minimum eigen value detection (CMME).
- To implement the two stage spectrum sensing using energy detection (ED) and combination of maximum minimum eigen value detection (CMME) technique.
- To analyse the detection performance of the two stage with respect to individual techniques.
- To implement the diversity techniques like Equal gain combining (EGC) and Maximal ratio combining (MRC) by considering Rayleigh channel along with AWGN noise and to compare its detection performance.
- To implement optimal cooperative spectrum sensing by considering single user and multi user case.

1.6 Thesis format

This thesis is composed of six chapters. The background details of Cognitive Radio (CR), its functions and roles, information regarding TV White Spaces (TVWS) and Software Defined Radios (SDRs) are discussed in the current chapter. The objective for this thesis work is written after literature review and motivation. This chapter ends with the outline of the thesis.

Chapter-2 Spectrum Sensing Techniques

This chapter discusses in detail of the basic transmitter detection techniques like Energy Detection (ED), Eigen-value based detection and cyclostationary detection (CSD) techniques. The advantages and disadvantages are also discussed after each technique. Comparison of all the three techniques is presented at the end of the chapter.

Chapter-3 Two Stage Spectrum Sensing using ED and CMME

This chapter includes the implementation of two stage technique. The mathematical analysis regarding the thresholds is carried out. The Two Stage Spectrum Sensing using ED and CMME is implemented by taking BPSK and DVB-T as input signals. The individual performance of each technique is compared with the two stage technique using ED and CMME. The comparison between two stage technique using ED and CSD and two stage technique using ED and CMME is presented.

Chapter-4 Cooperative Spectrum Sensing

Cooperative Spectrum Sensing describes the drawbacks in Spectrum Sensing and the advantages in Cooperative SS. Presented diversity techniques like EGC and MRC. The comparison between two techniques w.r.t Probability of detection (P_d) is presented. Optimal linear cooperation framework for SS is to identify the weak PU accurately is presented. Global decision is made by using Modified Deflection Coefficient (MDC) method. The comparison between single user and global decision using MDC is presented.

Chapter-5 Conclusion and Scope of Future work

This last chapter is the conclusion and scope of future work of the Optimal Cooperative Spectrum Sensing.

2

Spectrum Sensing Techniques

Spectrum sensing is a base for the performance of all functions performed by the Cognitive Radio (CR). So the effective performance of spectrum sensing is very essential for CR. Hence very active research is ongoing on spectrum sensing over recent years [2]. Cognitive radio has the ability to estimate the information regarding its operating environment and it recognizes the unused spectrum and shares it to SUs without creating interference to PU's (E.g. Cellular Networks, TV). The possible problems with spectrum sensing are Shadowing, Multi-path fading and Receiver uncertainty issues etc.

Spectrum sensing techniques are mainly classified into three types [4]:

- (i) Transmitter detection
- (ii) Interference based detection
- (iii) Cooperative detection

Transmitter detection methods are Energy Detection (ED) [15], Matched Filter (MF), Eigen-value based detection and cyclostationary detection technique (CSD). Cooperative detection techniques include centralized, distributed and cluster-based sensing schemes.

(i) Transmitter Detection

2.1 Energy Detection Technique

Energy detection (ED) technique is the simplest and popular spectrum sensing scheme. The received signal at CR receiver is given by [5],

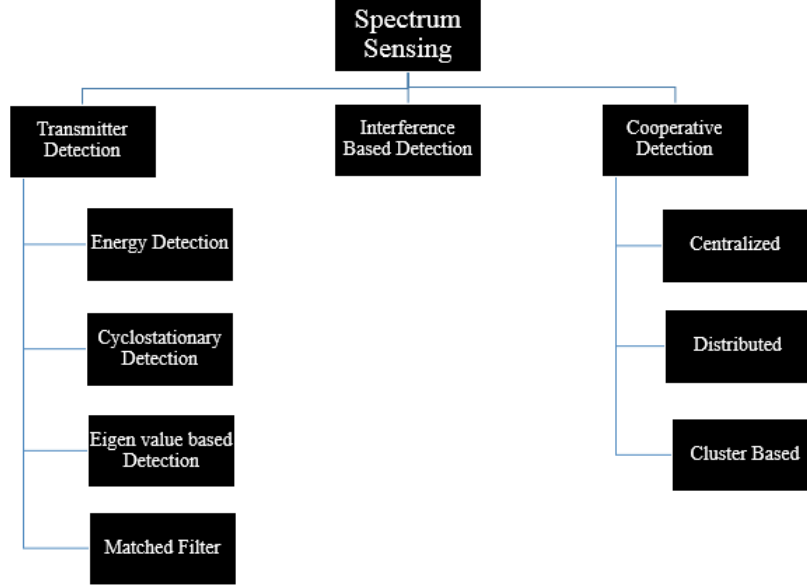

Figure 2.1: Spectrum Sensing techniques [4]

$$y(n) = \begin{cases} s(n) + w(n) & H_1 \\ w(n) & H_0 \end{cases} \quad (2.1)$$

Where $s(n)$ is the PU signal and $w(n)$ is the Additive White Gaussian Noise (AWGN). The presence of PU signal is represented by the hypothesis H_1 and the absence of PU signal is represented by the hypothesis H_0 .

In any detection technique, while detecting the presence of PU there are two possibilities of errors that can take place in fixing the threshold value. In the first case, if the threshold value is too high the detection device fails to recognize the presence of PU signal even though the PU signal is present. This type of error in decision making is known as Probability of Misdetection (P_{md}) [16]. Because of this error the SU tries to use that frequency channel which leads to interference and it is not desirable. In the second case, if the threshold value is too low the detection device detects the presence of PU signal even though the PU signal is not present. This type of error in technical terms is known as Probability of false alarm (P_f). Because of this error the SU not able to use that frequency channel which leads to the underutilization of spectrum and it is not

diserable [17].

For an optimum detector, it is necessary to minimize both the (P_{md}) and (P_f) where [12]

$$P_d = P(H_1|H_1) \quad (2.2)$$

$$P_{fa} = P(H_1|H_0) \quad (2.3)$$

$$P_{md} = 1 - P_d \quad (2.4)$$

The decision statistic for energy detector is given by,

$$T(y) = \frac{1}{N_{ED}} \sum_{n=1}^{N_{ED}} |y(n)|^2 \quad (2.5)$$

where N_{ED} is the number of samples present in the received signal, $N_{ED} = \tau f_s$ (should not be greater than τf_s), τ is the available sensing time and f_s is the sampling frequency if the received signal.

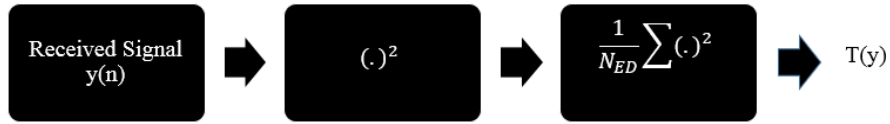

Figure 2.2: Energy Detector block diagram [5]

The probability of detection ($P_{d,ED}$) of ED technique is given by [5],

$$P_{d,ED}(\Phi_{ED}, \tau) = Q\left(\left(\frac{\Phi_{ED}}{\sigma_w^2} - \gamma - 1\right) \sqrt{\frac{\tau f_s}{2\gamma + 1}}\right) \quad (2.6)$$

$$Q^{-1}(P_{d,ED}) = \left(\left(\frac{\Phi_{ED}}{\sigma_w^2} - \gamma - 1\right) \sqrt{\frac{\tau f_s}{2\gamma + 1}}\right) \quad (2.7)$$

where $\gamma = \frac{\sigma_s^2}{\sigma_w^2}$, signal to noise ratio (SNR) of the received PU signal computed at the secondary receiver, Φ_{ED} is the detection threshold.

σ_s^2 , σ_w^2 are the variances of the primary signal $s(n)$ and noise $w(n)$.

The relation between the threshold, Φ_{ED} and probability of false alarm, $P_{f,ED}$, is given as:

$$P_{f,ED} = Q \left(\left(\frac{\Phi_{ED}}{\sigma_w^2} - 1 \right) \sqrt{\tau f_s} \right) \quad (2.8)$$

$$Q^{-1}(P_{f,ED}) = \left(\left(\frac{\Phi_{ED}}{\sigma_w^2} - 1 \right) \sqrt{\tau f_s} \right) \quad (2.9)$$

The probability of detection ($P_{d,ED}$) and probability of false alarm ($P_{f,ED}$) are related as follows:

$$Q^{-1}(P_{d,ED}) = \left(\left(\frac{\Phi_{ED}}{\sigma_w^2} - 1 \right) \sqrt{\frac{\tau f_s}{2\gamma + 1}} - \gamma \left(\sqrt{\frac{\tau f_s}{2\gamma + 1}} \right) \right) \quad (2.10)$$

$$\frac{Q^{-1}(P_{f,ED})}{\sqrt{2\gamma + 1}} = Q^{-1}(P_{d,ED}) + \gamma \left(\sqrt{\frac{\tau f_s}{2\gamma + 1}} \right) \quad (2.11)$$

$$Q^{-1}(P_{f,ED}) = Q^{-1}(P_{d,ED}) \left(\sqrt{2\gamma + 1} \right) + \gamma \sqrt{\tau f_s} \quad (2.12)$$

$$P_{f,ED} = Q \left(Q^{-1}(P_{d,ED}) \left(\sqrt{2\gamma + 1} \right) + \gamma \sqrt{\tau f_s} \right) \quad (2.13)$$

$$P_{d,ED} = Q \left(\frac{Q^{-1}(P_{f,ED})}{\sqrt{2\gamma + 1}} - \gamma \sqrt{\tau f_s} \right) \quad (2.14)$$

Simulation Results:

2.1.1 Comparison of energy detection technique (ED) under Rayleigh channel along with AWGN and AWGN:

Rayleigh channel along with AWGN:

The received signal distorted by Rayleigh channel with flat fading (designed as a filter (single tap) with complex impulse response h) also adds AWGN noise is represented as,

$$y = h * s + n \quad (2.15)$$

where

n is the AWGN noise which is normally distributed with mean zero and variance one.

h is the Rayleigh fading response with mean zero and variance one.

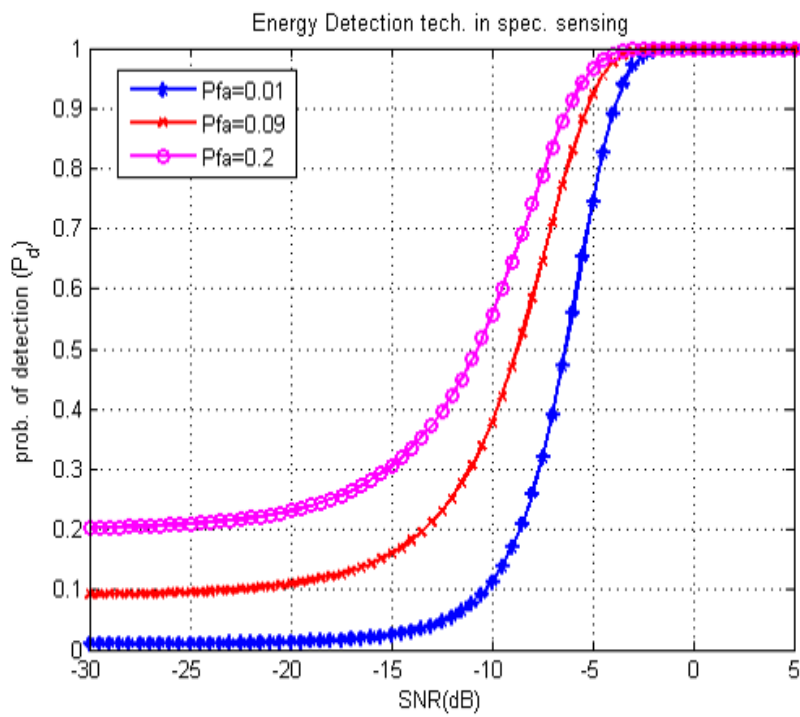
Figure 2.3: P_d vs SNR

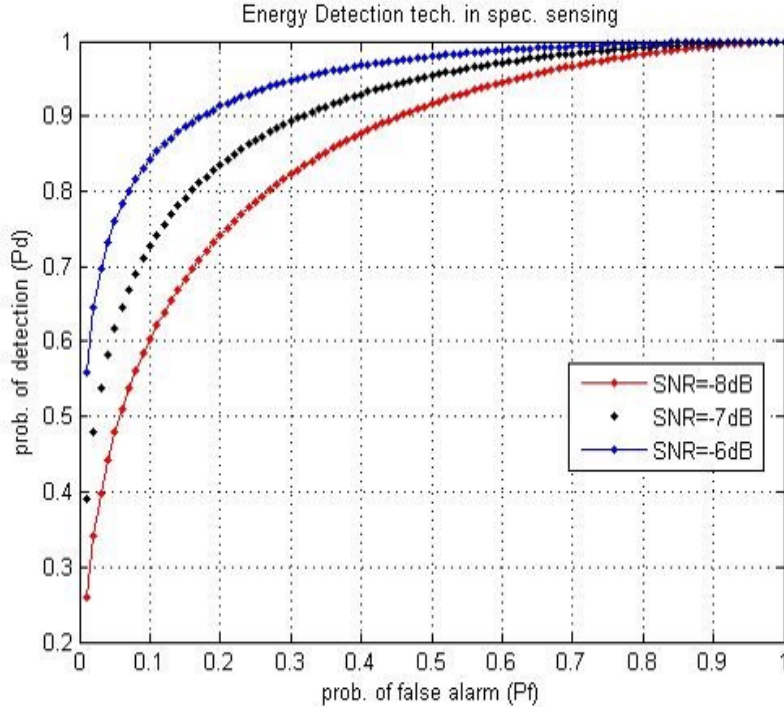
Figure 2.4: P_d vs P_f **AWGN:**

The received signal under AWGN channel without any Rayleigh fading is represented as,

$$y = s + n \quad (2.16)$$

Simulation Results:

From Figure 2.6, for Rayleigh channel along with AWGN noise the Probability of Misdetction ($P_{md}=0.3$) which implies the Probability of Detection ($P_d = 1 - P_{md}=0.7$) which is low compared to the performance, when only AWGN noise is considered. The Probability of Misdetction ($P_{md}=0.002$) which implies the Probability of Detection ($P_d = 1 - P_{md}=0.998$) which is better compared to the performance of Rayleigh channel along with AWGN noise is considered.

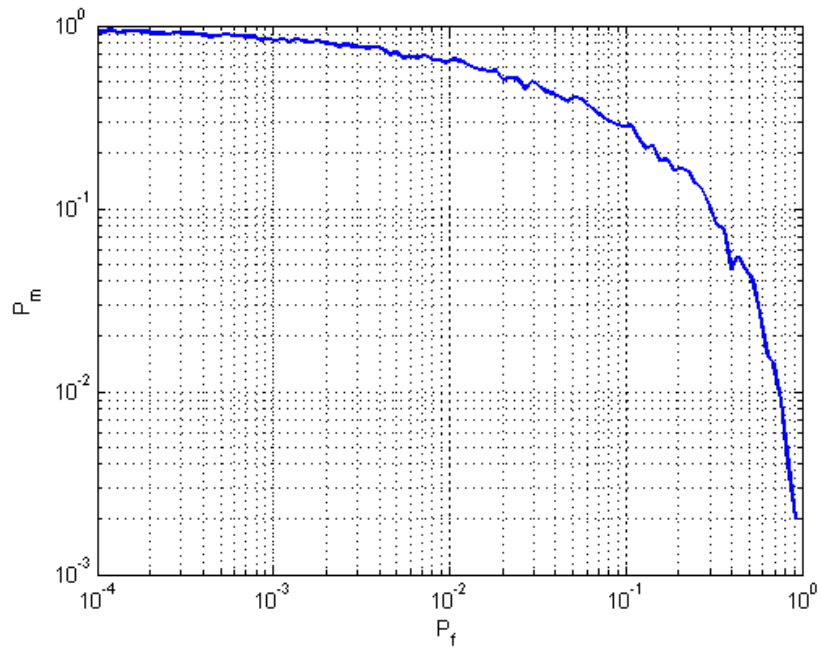
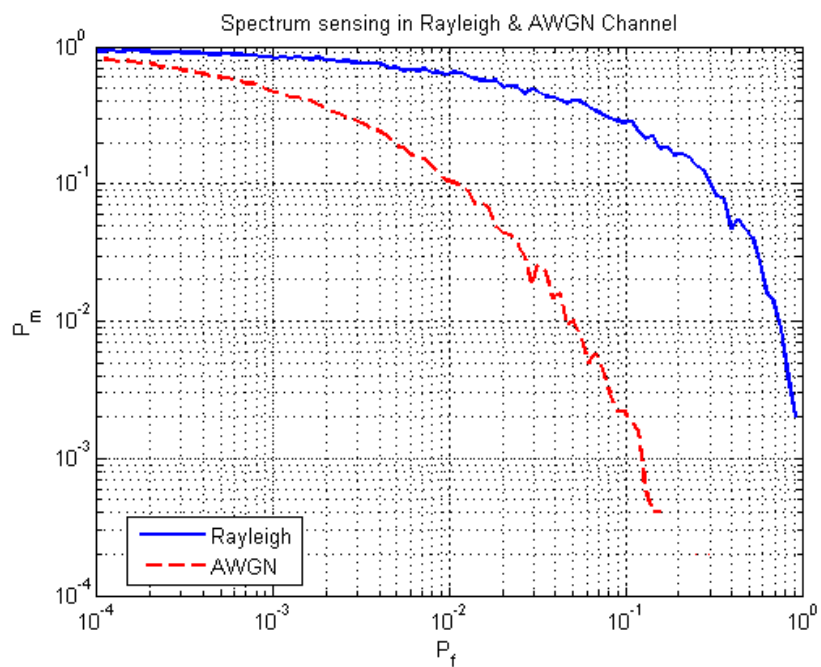

Figure 2.5: Spectrum Sensing in Rayleigh channel along with AWGN

Figure 2.6: P_d vs P_f

Advantages:

- Prior knowledge of the licensed user is not required.
- Performs well with unknown dispersive channels.
- Less computational and implementation complexity.
- Less delay relative to other techniques.

Disadvantages:

- ED technique depends on the information of accurate noise power because of this it is greatly affected by noise uncertainty.
- ED technique gives better performance at high SNRs for detecting independent and identically distributed (iid) signals, but not optimal for detecting correlated signals.

2.2 Cyclostationary detection technique:

A signal consists of frequency or spectral components constant w.r.t time is known as stationary [18]. For example generate a sine wave by using either a function generator or software, the selected frequency value is constant. Thus the frequency component of the sine wave is constant with time, which we can consider as one of the examples of stationary signal. By changing the frequency, it becomes a new sine wave [9].

$$x(k) = \begin{cases} s(k) + n(k) & H_1 \\ n(k) & H_0 \end{cases} \quad (2.17)$$

For example, consider two dice, one of which comprises of six sides, and the alternate has nine sides. Roll a six-sided die on Sundays, Mondays, Tuesdays and Wednesdays, and the nine-sided die for the rest of the days in a week. It is expected to get a mean of 3.5 on the days where a six-sided die is used, and a mean of 5 on the days where a nine-sided die is used [19]. Therefore the statistics do vary with time, so they are not stationary. In fact, they change periodically (i.e. weekly), and the process is said to be 'cyclostationary'.

A signal having statistical properties that change periodically with time is known as cyclostationary process. These processes are not periodic with time but their statistical properties shows periodicities [20]. These periodicities occur for signals in precised manner due to processes such as sampling, scanning, modulating, multiplexing, and coding. A signal is said to be wide sense cyclostationary, if the following conditions are satisfied [9]:

$$\begin{aligned}\mu_x(k) &= \mu_x(k + K'), \forall k \\ R_x(k, K) &= R_x(k + K', K), \forall (k, K)\end{aligned}\quad (2.18)$$

where

$k = 1, 2, \dots, N_{CSD}$, N_{CSD} is the number of samples present in the received signal of Cyclostationary detection technique.

$\mu_x(k) = E[x(k)]$ is the mean and $R_x(k, K) = E[x(k)x^*(k + K)]$ is the autocorrelation function and K is called the cyclic period [21].

Because of the periodicity the Fourier-series representation of the autocorrelation function of received signal in Cyclostationary detection technique is given as [9],

$$R_x(k, K) = \sum_{\alpha} R_x^{\alpha}(K) e^{j\alpha k}, \quad (2.19)$$

In (2.19) the Fourier series coefficients are

$$R_x^{\alpha}(K) = \lim_{N_{CSD} \rightarrow \infty} \frac{1}{N_{CSD}} \sum_{k=0}^{N_{CSD}-1} R_x(k, K) e^{-j\alpha k} \quad (2.20)$$

with $R_x^{\alpha}(K)$ is called cyclic autocorrelation function and α is called the cyclic frequency.

To check whether $R_x^{\alpha}(K)$ is null for a given candidate cycle [9], take up

$$\widehat{R}_x^{\alpha}(K) = R_x^{\alpha}(K) + \epsilon_x^{\alpha}(K) \quad (2.21)$$

where $\epsilon_x^{\alpha}(K)$ is the estimation error which vanishes as $N_{CSD} \rightarrow \infty$

For the simultaneous verification of presence of cycles in a set of lags K , the vector in (2.21) is considered than the single value.

Here K_1, K_2, \dots, K_N be the fixed set of lags [9].

$$\begin{aligned} \widehat{R}_x = & [R \{ \widehat{R}_x^\alpha(K_1) \}, R \{ \widehat{R}_x^\alpha(K_2) \}, \dots, R \{ \widehat{R}_x^\alpha(K_N) \}, \\ & I \{ \widehat{R}_x^\alpha(K_1) \}, I \{ \widehat{R}_x^\alpha(K_2) \}, \dots, I \{ \widehat{R}_x^\alpha(K_N) \}] \end{aligned} \quad (2.22)$$

represents a $1 \times 2N$ vector consists of cyclic correlation estimators from Equation (2.22) where R and I represents the real and imaginary parts respectively [22].

If the asymptotic value of \widehat{R}_x is given as R_x where

$$\begin{aligned} R_x = & [R \{ R_x^\alpha(K_1) \}, R \{ R_x^\alpha(K_2) \}, \dots, R \{ R_x^\alpha(K_N) \}, \\ & I \{ R_x^\alpha(K_1) \}, I \{ R_x^\alpha(K_2) \}, \dots, I \{ R_x^\alpha(K_N) \}] \end{aligned} \quad (2.23)$$

and the estimation error is given as,

$$\begin{aligned} \epsilon_x = & [R \{ \epsilon_x^\alpha(K_1) \}, R \{ \epsilon_x^\alpha(K_2) \}, \dots, R \{ \epsilon_x^\alpha(K_N) \}, \\ & I \{ \epsilon_x^\alpha(K_1) \}, I \{ \epsilon_x^\alpha(K_2) \}, \dots, I \{ \epsilon_x^\alpha(K_N) \}] \end{aligned} \quad (2.24)$$

The decision statistic of the Cyclostationary detector is given as,

$$D_{CSD} = N_{CSD} \widehat{R}_x \widehat{C}_v^{-1} \widehat{R}_x^H \quad (2.25)$$

where \widehat{C}_v is the covariance matrix of \widehat{R}_x . From equation (2.25) of Cyclostationary detector, if the $D_{CSD} \geq \gamma$ it can be declared that the particular frequency channel is occupied by PU and α is the cyclic frequency else it can be declared that the PU is absent and α is not the cyclic frequency, the frequency channel can be accessed by the SU [23].

We can get the Probability of detection, $P_{d,CSD}$, and false alarm, $P_{f,CSD}$ as,

$$P_{f,CSD} = P(D_{CSD} \geq \gamma | H_0) = \frac{\Gamma(\frac{\gamma}{2}, N)}{\Gamma(N)} \quad (2.26)$$

$$P_{d,CSD} = P(D_{CSD} \geq \gamma | H_1) = Q \left(\frac{\gamma - N_{CSD} \widehat{R}_x \widehat{C}_v^{-1} \widehat{R}_x^H}{\sqrt{4N_{CSD} \widehat{R}_x \widehat{C}_v^{-1} \widehat{R}_x^H}} \right) \quad (2.27)$$

where $\Gamma(a)$ is the gamma function and $\Gamma(a, x)$ is the incomplete gamma function ($\Gamma(a, x) = \int_x^\infty t^{a-1} e^{-t} dt$).

Simulation Results:

Figure 2.7: Cyclostationary detection technique

From the Fig 2.7, it is observed that the Probability of detection, $P_{d,CSD}$ at SNR=-20dB is 0.85 by considering Probability of false alarm, $P_{f,CSD}$ as 0.03. Whereas the Probability of detection, $P_{d,ED}$ of ED at SNR=-20dB is 0.3 by considering Probability of false alarm, $P_{f,ED}$ as 0.03. It is clear from the detection values that the performance of CSD is better compared to ED technique.

Advantages

- Under low SNRs and uncertain noise powers cyclostationary detector can perform better than the energy detector.
- This technique recognize the signal of PU at low SNR values by taking the information which is present in the received signal if the signal of PU have good cyclostationary probabilities.

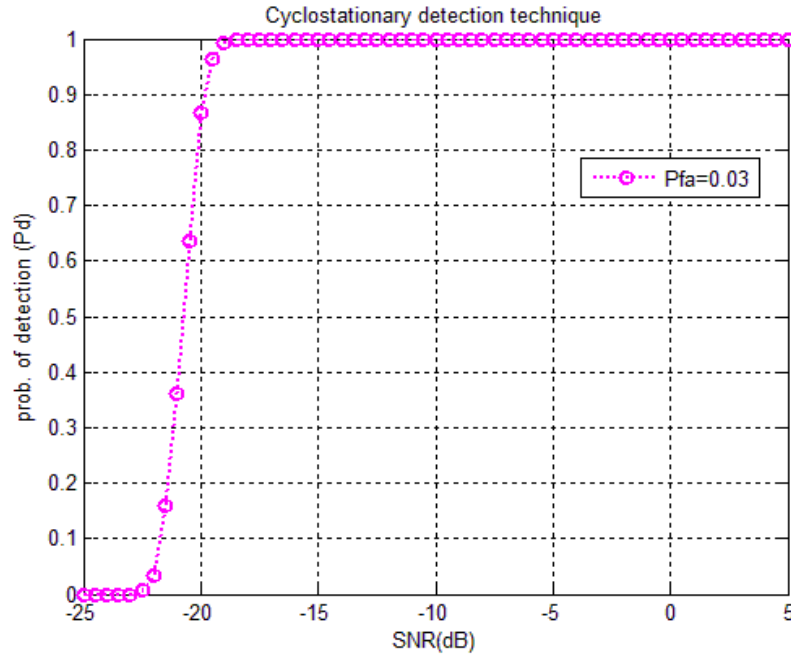
Disadvantages

- CSD needs more signal processing capabilities and is complicate to implement.

2.3 Combination of Maximum Minimum Eigenvalue based detection technique:

The decision threshold is the ratio between maximum eigenvalue and noise power, which is considered in [24]. Due to noise uncertainty MED performance is low. In [25], it is proposed that Maximum Minimum eigenvalue based method (MME) which uses the maximum eigenvalue to minimum eigenvalue ratio of the received signal's covariance matrix to recognize the existence of signal. This thesis includes an algorithm which is implemented by taking combination of maximum and minimum eigenvalues (CMME) as the decision statistic. To analyze the sensing methodology and to set the threshold random matrix theory is used [26]. Because of the correlations present between the the signal samples which is noticed during the calculation of covariance matrix, the CMME scheme performs better than the energy detection in case of correlated signals [27].

CMME works better in low SNR with correlated signals without having prior information about PU and channel noise [27][11][24]. Assuming $K \geq 1$ SU's. Then the received signal at the i^{th} SU is denoted by $x_i(k)$ ($i = 1, 2, \dots, K$). Then the statistical matrix can be defined as [28]:

$$\begin{aligned} x(k) &= [x_1(k), x_2(k), \dots, x_K(k)]^T \\ s(k) &= [s_1(k), s_2(k), \dots, s_K(k)]^T \\ n(k) &= [n_1(k), n_2(k), \dots, n_K(k)]^T \end{aligned} \quad (2.28)$$

Where the received signal is given by $x(k)$, ($k = 1, 2, \dots, N$) where N is the number of samples in CMME technique. $s(k)$ is the signal transmitted passed through a wireless channel and $n(k)$ is the AWGN with variance σ_n^2 and mean zero.

According to the above definitions, (1) can be written as,

$$x = s + n \quad (2.29)$$

Considering the statistical covariance of the received signal, transmitted

signal and noise signal as [11],

$$\begin{aligned} R_x &= E(xx^T) \\ R_s &= E(ss^T) \\ R_n &= E(nn^T) \end{aligned} \quad (2.30)$$

Let us consider N consecutive samples, then the statistical covariance matrices of the received signal, transmitted signal and noise signal becomes [11],

$$\begin{aligned} R_x(N) &= \frac{1}{N}xx^T \\ R_s(N) &= \frac{1}{N}ss^T \\ R_n(N) &= \frac{1}{N}nn^T \end{aligned} \quad (2.31)$$

Assuming that the noise is real. Let $A(N) = \frac{N}{\sigma_n^2}R_n(N)$, $\mu = \left(\sqrt{N-1} + \sqrt{K}\right)^2$, $\nu = \left(\sqrt{N-1} + \sqrt{K}\right) \left(\frac{1}{\sqrt{N-1}} + \frac{1}{\sqrt{K}}\right)^{1/3}$. Assume that $\lim_{N \rightarrow \infty} \frac{K}{N} = \alpha$ ($0 < \alpha < 1$). Then $\frac{\lambda_{max}(A(N)) - \mu}{\nu}$ converges (with probability one) to the Tracy-Widom distribution of order 1 as mentioned in [27][11] [10]. Assuming that the noise is complex. Let $A(N) = \frac{N}{\sigma_n^2}R_n(N)$, $\mu' = \left(\sqrt{N} + \sqrt{K}\right)^2$, $\nu' = \left(\sqrt{N} + \sqrt{K}\right) \left(\frac{1}{\sqrt{N}} + \frac{1}{\sqrt{K}}\right)^{1/3}$. Assume that $\lim_{N \rightarrow \infty} \frac{K}{N} = \alpha$ ($0 < \alpha < 1$). Then $\frac{\lambda_{max}(A(N)) - \mu'}{\nu'}$ converges (with probability one) to the Tracy-Widom distribution of order 2 [11].

If N is large then, μ and μ' , ν and ν' are nearly same, but their limit distribution is not same [27]. From [24] which provides details about the tables for Tracy-Widom distribution function that are calculated by numerical computation. For example $F_1^{-1}(0.9) = 0.45$, $F_1^{-1}(0.5) = 0.98$, $F_1^{-1}(0.99) = 2.02$

λ_{max} and λ_{min} are the maximum and minimum eigen values of the received statistical covariance matrix ($R_x(N)$).

Algorithm [11]

$$P_{f,eig} = P\left(\lambda_{max} > \gamma'(\lambda_{max} - \lambda_{min})\right) \quad (2.32)$$

From above assumptions, we can get:

$$P_{f,eig} = P\left(\frac{\sigma^2}{N}\lambda_{max}(A(N)) > \gamma'(\lambda_{max} - \lambda_{min})\right) \quad (2.33)$$

$$\approx P\left(\lambda_{max}(A(N)) > \gamma'\left(\sqrt{N} - \sqrt{K}\right)^2\right) \quad (2.34)$$

$$= 1 - F_1 \left(\frac{\gamma' (\sqrt{N} - \sqrt{K})^2 - \mu}{\nu} \right) \quad (2.35)$$

$$P_{d,eig} = Q \left(\frac{\gamma_2 - \left(\frac{\lambda_{max}}{\lambda_{max} - \lambda_{min}} \right)}{\sqrt{4N \left(\frac{\lambda_{max}}{\lambda_{max} - \lambda_{min}} \right)}} \right) \quad (2.36)$$

Let

$$\gamma' = \frac{(\sqrt{N} + \sqrt{K})^2}{(\sqrt{N} - \sqrt{K})^2} \left(1 + \frac{(\sqrt{N} + \sqrt{K})^{-2/3}}{(NK)^{1/6}} \right) \star (F_1^{-1}(1 - P_{f,eig})) \quad (2.37)$$

The threshold 2 is: $\gamma_2 = \frac{\gamma'+1}{\gamma'} = 1 + \frac{1}{\gamma'}$.

Therefore, the judgment rule for CMME detection technique is [29]

[11]:

$$D_{eig} = \frac{\lambda_{max}}{\lambda_{max} - \lambda_{min}} \begin{array}{c} H_1 \\ > \\ < \\ H_0 \end{array} \gamma_2 \quad (2.38)$$

If the decision is more than the threshold, it can be declared that the PU is present else the particular frequency channel is empty.

Simulation Results:

From the Fig 2.8, it is observed that the Probability of detection, $P_{d,eig}$ at SNR=-20dB is 1 by considering Probability of false alarm, $P_{f,eig}$ as 0.03. Where as the Probability of detection, P_d of ED and CSD at SNR=-20dB is 0.3 and 0.85 by considering Probability of false alarm, $P_{f,ED}$ as 0.03. It is clear from the detection values that the performance of CMME is better compared to ED and CSD techniques.

Advantages:

- Without having any information of the PU signals, noise power and channel, high detection probability (P_d) and low false alarm probability (P_f) can be achieved by using this technique. Hence this technique avoids the problem

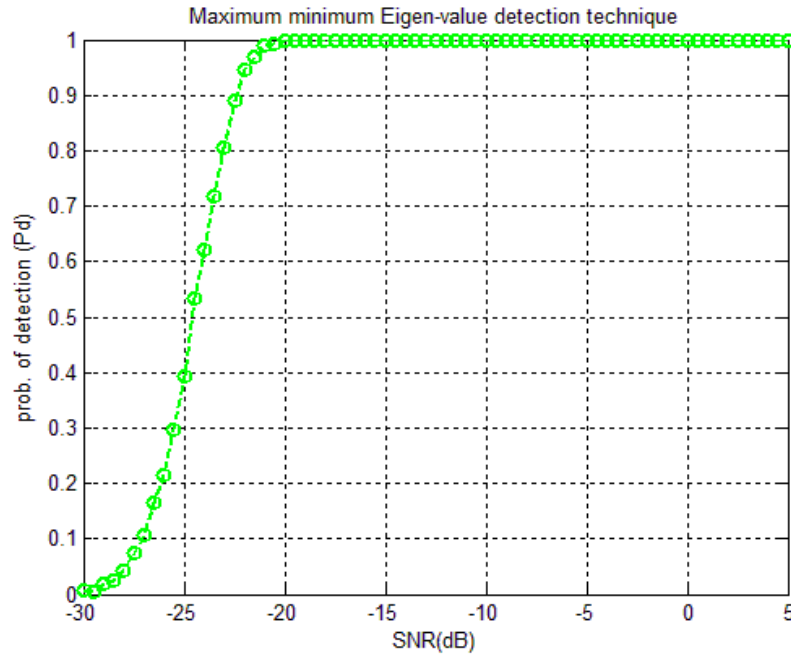

Figure 2.8: Combination of Maximum Minimum Eigen value based detection technique

of noise uncertainty experienced by energy detector.

- This technique doesn't require synchronization.
- Because of the correlations present between the the signal samples which is noticed during the calculation of covariance matrix, the CMME scheme performs better than the energy detection in case of correlated signals.

Disadvantages:

- This technique is more complicate than the energy detector.

2.4 Comparison of ED, CSD and CMME techniques

The individual performance of each technique is shown in the Figure 2.9. The drawbacks of Energy Detection technique (ED) i.e., poor performance at low SNR which is giving 0 probability of detection (P_d) at -20dB can overcome by using

CSD and CMME techniques. From the Figure 2.9 we can observe at low SNR i.e., CSD giving probability of detection (P_d) of 0.85 at -20dB and CMME giving 1 at -20dB, which is better than the ED.

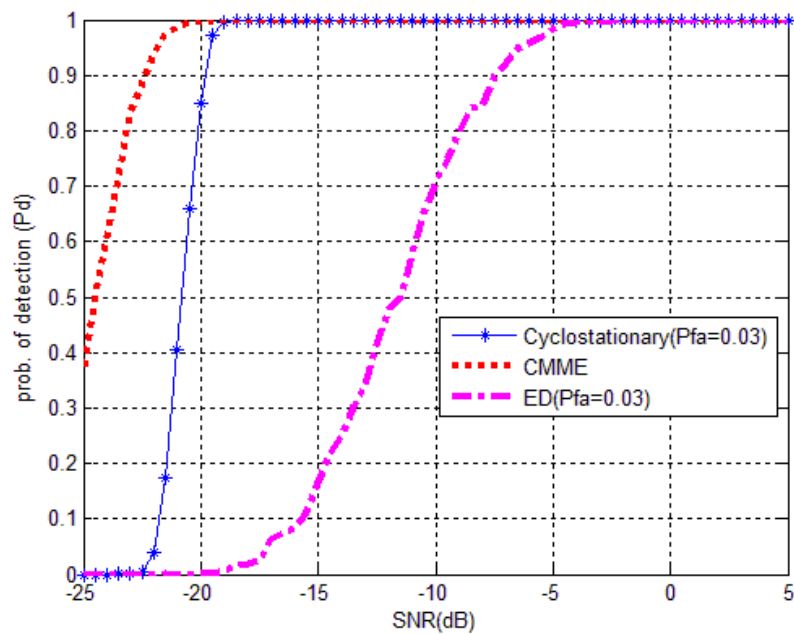

Figure 2.9: Comparison of ED, CSD and CMME techniques

3

Two Stage Spectrum Sensing using ED and CMME

In [30], two threshold ED technique is considered in coarse sensing first stage and single threshold CSD technique is considered in fine sensing second stage to enhance the sensing speed and accuracy. In [9], the two stage sensing was proposed by considering ED as coarse sensing first stage and CSD as fine sensing second stage to enhance the detection performance and timing analysis was also proposed. The signal should possess cyclostationary feature to implement CSD technique, which may be caused by modulation and coding or it may be provided purposely like the cyclic prefix (CP) in an OFDM signal. This chapter includes the implementation of two stage technique using ED and CMME. The mathematical analysis regarding the thresholds is carried out. The Two Stage Spectrum Sensing (SS) using ED and CMME is implemented by taking BPSK and DVB-T as input signals. The transmitted OFDM signal is organised in frames. Every frame has 68 OFDM symbols with 1705 sub-carriers in 2k mode and transmitted with a symbol duration of $T_s = 244 \mu\text{sec}$ [31]. The individual performance of each technique is compared with the two stage technique using ED and CMME. The comparison between two stage SS technique using ED and CSD [15] and two stage SS technique using ED and CMME is observed. The Two Stage SS using ED and CSD is implemented in [9] which is giving good performance than individual ED and CSD techniques but the Two Stage SS technique using ED and CMME is giving better detection probability than the Two Stage SS using ED and CSD techniques.

3.1 Two Stage Spectrum Sensing Scheme

Analysis for two stage sensing is carried out quite similar to [9] by assumption to sense L channels. As suggested in IEEE 802.22 standard for CR, novel two stage spectrum sensing based on energy detection as coarse sensing first stage and combination of maximum-minimum eigen value based detection technique (CMME) as fine sensing second stage is proposed which enhances the accuracy, sensitivity and timing. If the decision is more than the threshold Φ_{ED} , then the channel is decided as occupied. Else the received signal is again sensed by using the second stage i.e., CMME technique [30]. If the decision is more than the threshold γ_2 , then the channel is considered as occupied else it is empty [30]. Proposed two stage sensing shown in Fig 3.1:

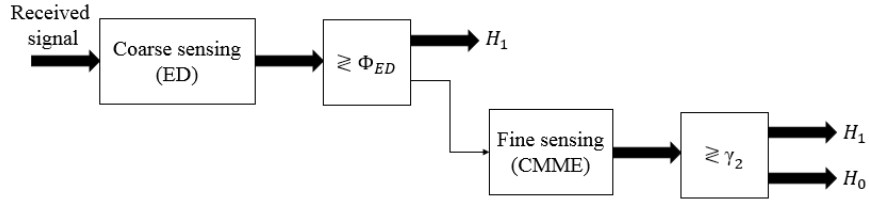

Figure 3.1: Two-stage spectrum sensing technique (ED and CMME detection technique)

3.2 Mathematical Analysis

The total probabilities of false alarm and detection for a single channel are as follows [9],

$$P_f = P_{f,ED} (1 - P_{f,ED}) P_{f,eig} \quad (3.1)$$

$$P_d = P_{d,ED} (1 - P_{d,ED}) P_{d,eig} \quad (3.2)$$

The objective is to determine the thresholds Φ_{ED} and γ_2 to maximize the probability of detection of each channel subject to a false alarm rate constraint. Therefore the corresponding problem is given by,

$$\max_{(\Phi_{ED}, \gamma_2)} P_d(\Phi_{ED}, \gamma_2) \quad (3.3)$$

$$s.t. P_f \leq \beta$$

The inequality constraint in the problem (3.3) is reduced to an equality constraint by using the theorem in [9].

Theorem: The optimal value of detection probability in (19) is obtained by $P_f = \beta$. Proof for the following is analysed similar to the [9] since P_d consists of Tracy-widom distribution function which is similar to Gaussian function (differentiable) and Q-function (differentiable). Hence P_d is differentiable and decreasing function w.r.to the thresholds Φ_{ED} and γ_2 [9]. Consequently, the first derivative of P_d w.r.t Φ_{ED} and γ_2 is negative. Hence, the maximum P_d is attained for the lowest possible Φ_{ED} and γ_2 . Same analysis holds for P_f . Assuming $(\Phi_{ED}^*, \gamma_2^*)$ to be the optimal solution of (3.3) corresponding to $P_f < \beta$. With keeping either of them Φ_{ED}^* or γ_2^* constant and varying one of them produce the better solution than as assumed. Therefore, $(\Phi_{ED}^*, \gamma_2^*)$ cannot be the optimal solution of the problem. Hence, the optimal P_d is obtained by $P_f = \beta$. Now equation (3.3) becomes [9],

$$\begin{aligned} \max_{(\Phi_{ED}, \gamma_2)} P_d(\Phi_{ED}, \gamma_2) \\ s.t. P_f = \beta \end{aligned} \quad (3.4)$$

Solving (3.1),

$$\beta = P_{f,ED} (1 - P_{f,ED}) P_{f,eig} \quad (3.5)$$

Substituting Probability of false alarm equations of ED and CMME techniques in (3.5), we get,

$$\Phi_{ED} = f(\gamma_2) = Q^{-1} \left(\frac{\beta - \left(1 - F_1 \left(\frac{\gamma'(\sqrt{N}-\sqrt{K})^2 - \mu}{\nu} \right) \right)}{1 - \left(1 - F_1 \left(\frac{\gamma'(\sqrt{N}-\sqrt{K})^2 - \mu}{\nu} \right) \right)} \right) \star \sqrt{2M^c \sigma_n^4} + M^c \sigma_n^2 \quad (3.6)$$

since $\gamma' = \frac{1}{\gamma_2 - 1}$.

Thus, the problem (3.4) can be reduced to an unconstrained problem given as:

$$\max_{\gamma_2} P_d(f(\gamma_2), \gamma_2) \quad (3.7)$$

The optimal γ_2 and $\Phi_{ED} = f(\gamma_2)$ can be obtained from (3.7) and

(3.6). So the problem is unimodal in γ_2 and the optimal value of γ_2 is calculated at each SNR which gives the maximum probability of detection (P_d), which can be observed from the Figure 3.4. The final optimal equation (P_d) which is the function of γ_2 can be evaluated in MATLAB.

Simulation Results:

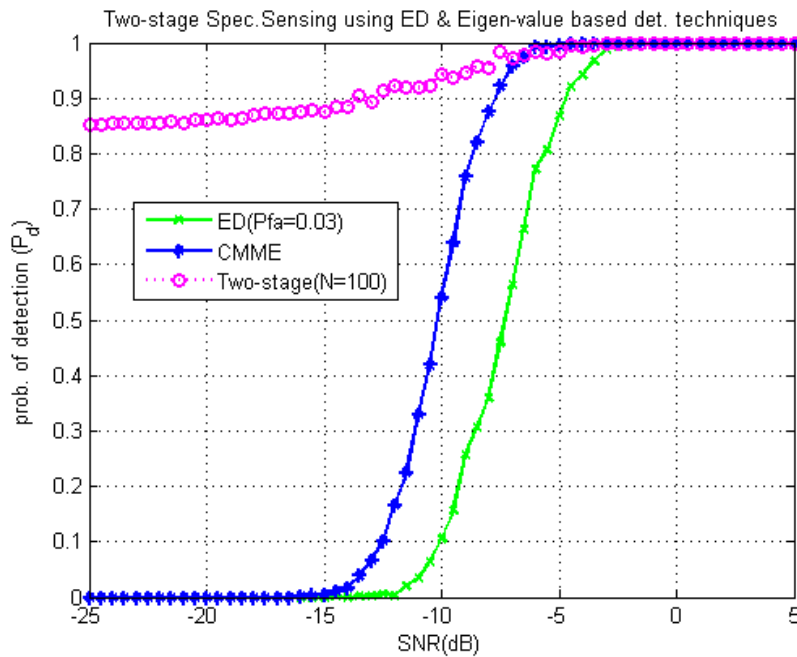

Figure 3.2: P_d vs SNR by taking BPSK as input signal ($N=100$)

3.3 Observation

From Table 3.1 we can observe that the probability of detection (P_d) is better for Two-stage spectrum sensing schemes compared to individual detection techniques in both the cases. The probability of detection (P_d) performance of two-stage spectrum sensing using ED and CMME is better compared to two-stage spectrum sensing using ED and CSD[9].

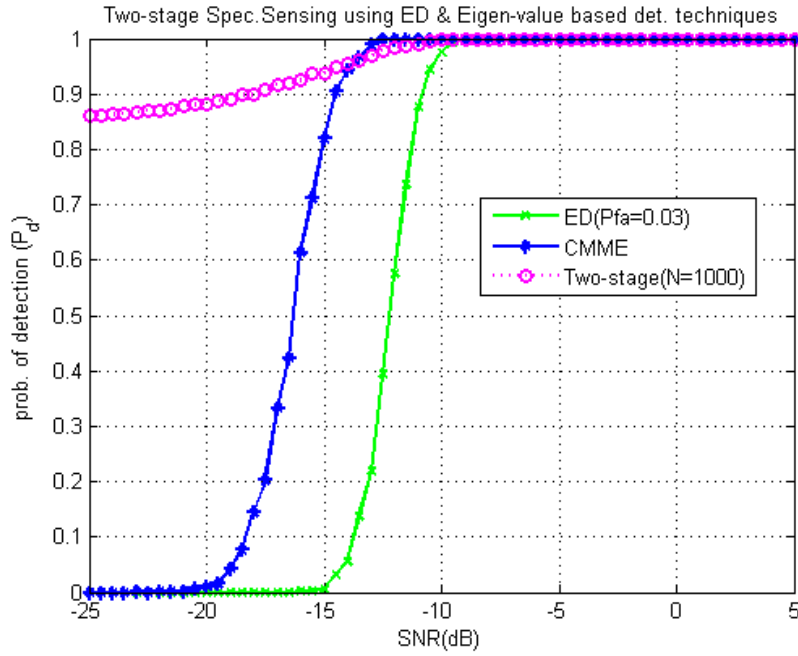

Figure 3.3: P_d vs SNR by taking BPSK as input signal ($N=1000$)

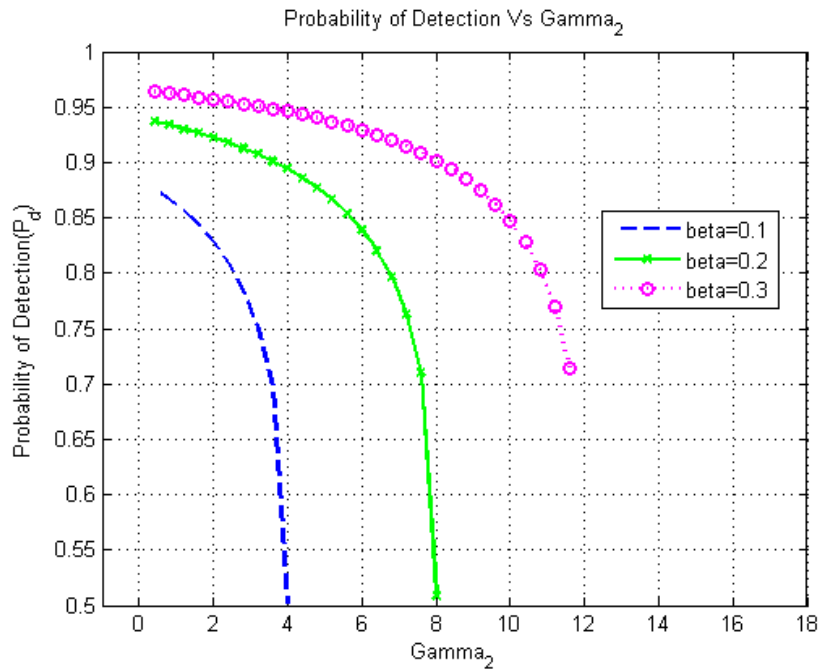

Figure 3.4: γ_2 vs P_d

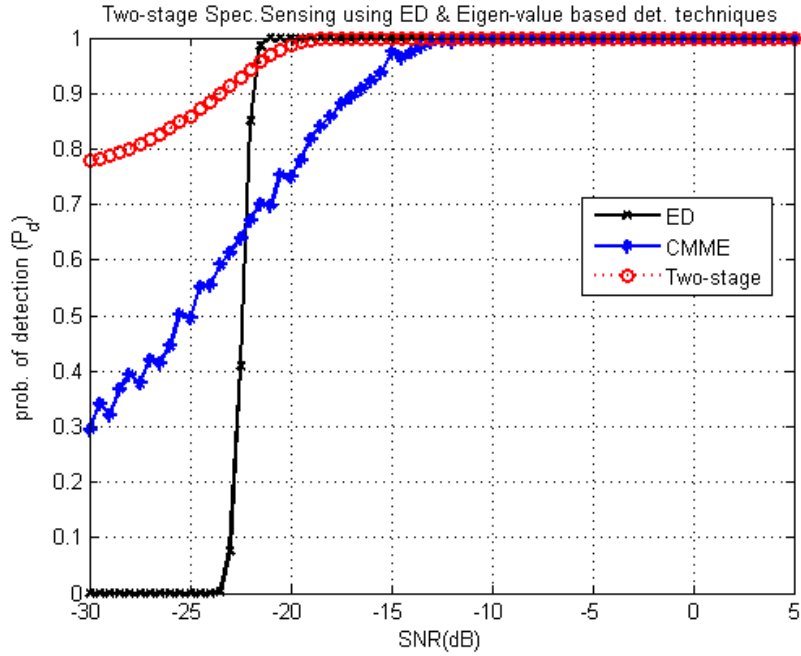

Figure 3.5: P_d vs SNR by taking DVB-T as input signal

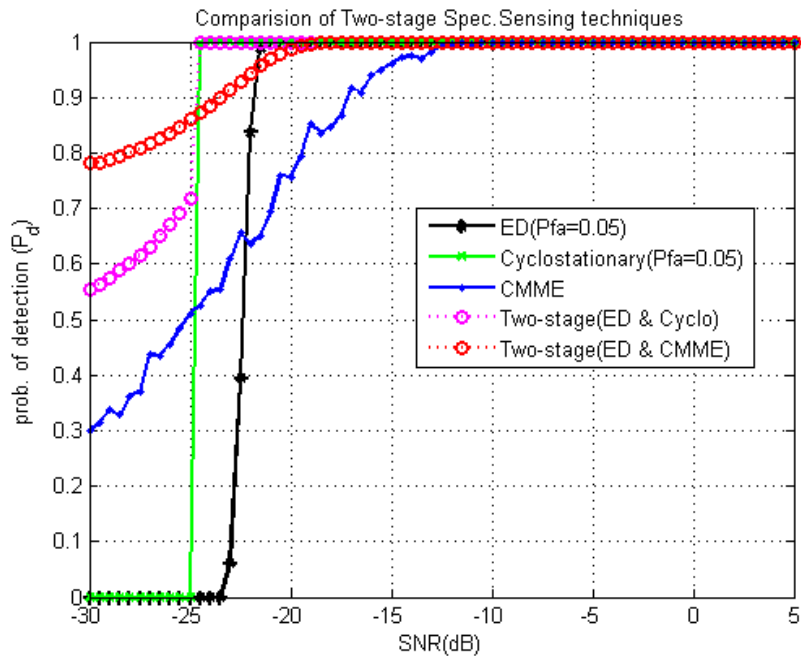

Figure 3.6: Comparison of Spectrum Sensing techniques

SNR (dB)	ED ($P_{d,ED}$)	CSD ($P_{d,CSD}$)	CMME ($P_{d,CMME}$)	Two-stage spec.sen. (ED-Cyclo) (P_d)	Two-stage spec.sen. (ED-CMME) (P_d)
-30	0	0	0.3	0.57	0.79
-23	0.1	1	0.62	1	0.92
-20	1	1	0.78	1	1

Table 3.1: Comparison of Prob. of detection P_d of spec.sen. tech's with SNR

4

Cooperative Spectrum Sensing

Spectrum sensing (SS) is less reliable if multi-path fading is ignored. For next generation systems using high transmit power or additional bandwidth, SNR improvement is not possible as it is against the requirements [32]. CR should approximate the power spectral density (PSD) of the radio spectrum before transmitting any signal to examine which frequency bands are busy and which are not [33]. Cognitive radio (CR) user and licensed user are separated by a building, the CR user not able to receive other user's signal and decides the spectrum is not occupied. The hidden node problem must overcome to protect PUs from interference. The possibility to avoid this problem is cooperative spectrum sensing technique. CR cooperative spectrum sensing [33] takes place when the information among CR's is shared.

The functioning of this method can be performed as:

- Local sensing is done by all CR's and a binary decision is made.
- The common receiver (R_x) receives binary decisions from all the cognitive radios, generally an access point (AP) in a WLAN or a base station (BS) in a cellular network.
- The common receiver (R_x) combines the received information and takes a final decision to decide the presence or absence of the PU in the observed band.

CR cooperative spectrum sensing takes place when a network of CR's share the detected information. This provides a better idea of the spectrum

utilization over the area where the cognitive radios are located.

The two approaches to cooperative spectrum sensing are [33]:

- **Centralised approach:** In this approach, a master node within the network that collects the detected information from all the sense nodes or radios. Then the master node analyses the detected information from all the sense nodes and determines which frequency bands are occupied and which are not.

The central node or controller organizes various sensor nodes to collect different measurements at different times. So, it is possible to take different sense actions at the same time. For example, directions may be given to some nodes to detect on channel signal levels, while other nodes may be instructed to measure levels on adjacent channels to determine suitable choices in case change of channel is required.

- **Distributed approach:** In this approach, no node takes control. Rather, communication lies between different nodes and they are able to share detected information. However, this approach requires for the individual radios have a more elevated amount of self-rule and setting themselves up as an ad-hoc network.

Advantages of cooperative spectrum sensing:

Cooperative spectrum sensing is more complicated than a single non-cooperative system, beyond complexity, it has many advantages. For all applications cooperative SS is not applicable. If it is applicable, reasonable improvements in system performance can be achieved [33].

- **Reduction of Hidden node problem:** One of the major problems under non-cooperative SS is that the Cognitive Radio (CR) may fail to recognize the presence of primary user and also there is a possibility of creating interference at receiver which can identify both PU and CRs. As the number of receivers are more in cooperative SS, the accuracy in detecting the presence of both PU and CRs can be increased.

- **Increase in agility:** As the number of spectrum sensing nodes are more the sensing accuracy is high.
- **Reduced false alarms:** As it consists of multiple nodes, accuracy is high in identifying a signal in the channel and this reduces the number of false alarms.
- **Signal detection accuracy:** It provides high signal detection accuracy and greater reliability of the system.

System requirements:

Cognitive Radio cooperative SS provides many advantages which outweigh the disadvantages [33].

- **Control channel:** Separate control channel is required for the communication among the nodes in the sensing network which occupies a proportion of the overall bandwidth.
- **System synchronization:** Synchronization is required among all the nodes in the CR cooperative SS network to keep the channel transmission free during the sensing period. Sometimes adaptive scheduling of the sense period is beneficial. Spectrum sensing requires a long time period to sense accurately than a rough sense to check whether a strong signal has returned. By adjusting the sense periods, channel throughput can be maximized, in spite of the fact that synchronization is important to maintain under these circumstances.
- **Suitable geographical spread of sensing nodes:** It is necessary to obtain the best geographical spread to gain the optimum sensing from the nodes within the cognitive network. In this way the hidden node problem can be minimized, and the most accurate SS can be attained.

Receiver diversity is a form of space diversity in which multiple antennas at the receiver are considered. It creates an interesting problem of collecting the data from all the antennas to demodulate the data.

4.1 Diversity techniques:

4.1.1 Equal Gain Combining (EGC)

Under EGC, the channel assumed as a multi-path Rayleigh flat fading channel and BPSK modulation is considered. Combining all the signals in a co-phased manner with unity weights for all signal levels so as to have the highest achievable SNR at the receiver at all times [34].

Background:

1. Here we assume the number of transmit antennas are one and the number of receive antennas are N .
2. Here we consider flat fading channel. So, the convolution becomes multiplication.
3. The channel varies randomly w.r.to time is experienced by each receive antenna. Here each transmitted data is multiplied with complex number h_i (which varies randomly) for the receiver antenna i . The imaginary and real parts of Rayleigh channel, h_i are distributed normally with mean $\mu_{h_i} = 0$ and variance $\sigma_{h_i}^2 = \frac{1}{2}$.
4. Each receiver antenna receives different channel and noise.
5. The noise n has the normal probability density function at every receive antenna, with

$$p(n) = \frac{1}{\sqrt{2\pi}\sigma^2} e^{-\frac{(n-\mu)^2}{2\sigma^2}} \quad (4.1)$$

here $\mu = 0$ and $\sigma^2 = \frac{N_0}{2}$

6. Each receiver has a knowledge about channel h_i .
7. The bit energy-to-noise ratio at i^{th} receive antenna in the presence of h_i is $\frac{|h_i|^2 E_b}{N_0}$.

$$\gamma_i = \frac{|h_i|^2 E_b}{N_0} \quad (4.2)$$

The pdf of γ_i is

$$p(\gamma_i) = \frac{1}{E_b/N_0} e^{-\frac{\gamma_i}{E_b/N_0}} \quad (4.3)$$

Here we equalize the i^{th} receiver by dividing the received data y_i by phase of h_i . Since the channel h_i is complex quantity, it can be denoted in polar form as

$|h_i| e^{j\theta_i}$ [35]. The decoded symbol can be determined by the addition of all phase compensated channel from all the receive antennas, which is given as,

$$\hat{y} = \sum_i \frac{y_i}{e^{j\theta_i}} \quad (4.4)$$

$$= \sum_i \frac{|h_i| e^{j\theta_i} x + n_i}{e^{j\theta_i}} \quad (4.5)$$

$$= \sum_i |h_i| x + \tilde{n}_i \quad (4.6)$$

where

$$\tilde{n}_i = \frac{n_i}{e^{j\theta_i}} \quad (4.7)$$

For demodulation, we use

$$\begin{aligned} \hat{y} > 0 &\rightarrow 1 \\ \hat{y} \leq 0 &\rightarrow 0 \end{aligned} \quad (4.8)$$

Simulation Results:

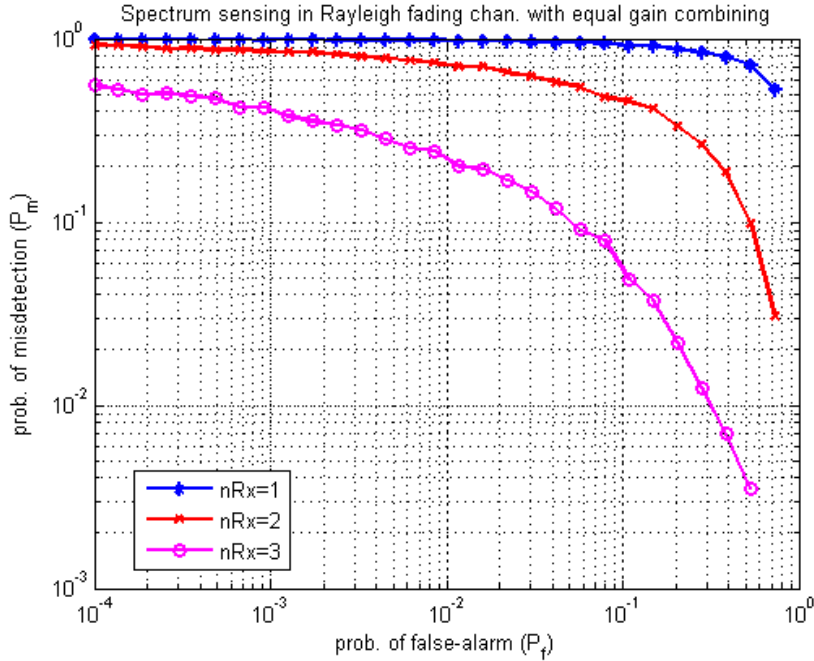

Figure 4.1: P_f vs P_{md} by varying the no. of receive antennas

The above procedure can be used to plot BER performance of Equal

Gain Combining (EGC). To detect the signal, the signals from all the receive antennas are summed after compensating the phase of the channel. Energy detection technique (ED) is applied to the received signal and performance is observed by varying the number of receive antennas.

4.1.2 Maximal Ratio Combining (MRC)

Combining all the signals in a co-phased and weighted manner so as to have the highest achievable SNR at the receiver at all times. Each signal of the branch is multiplied with the gain factor which is directly proportional to its own SNR [35].

The received signal at the i^{th} receiver is,

$$y_i = h_i x + n_i \quad (4.9)$$

where

y_i is the symbol received on the i^{th} receiver,

h_i is the channel on the i^{th} receiver,

x is the symbol transmitted and

n_i is the noise on the i^{th} receiver.

The received signal in matrix form is,

$$y = hx + n \quad (4.10)$$

where

$y = [y_1 y_2 \dots y_N]^T$ is the received symbol from all the receivers,

$h = [h_1 h_2 \dots h_N]^T$ is the channel,

x is the transmitted symbol and

$n = [n_1 n_2 \dots n_N]^T$ is the noise on all the receivers.

The equalized symbol is,

$$\hat{x} = \frac{h^H y}{h^H h} = \frac{h^H h x}{h^H h} + \frac{h^H n}{h^H h} = x + \frac{h^H n}{h^H h} \quad (4.11)$$

where the sum of channel powers over all the receivers is given by,

$$h^H h = \sum_{i=1}^N |h_i|^2 \quad (4.12)$$

Energy detection technique (ED) is applied to the received signal and performance is observed by varying the number of receive antennas.

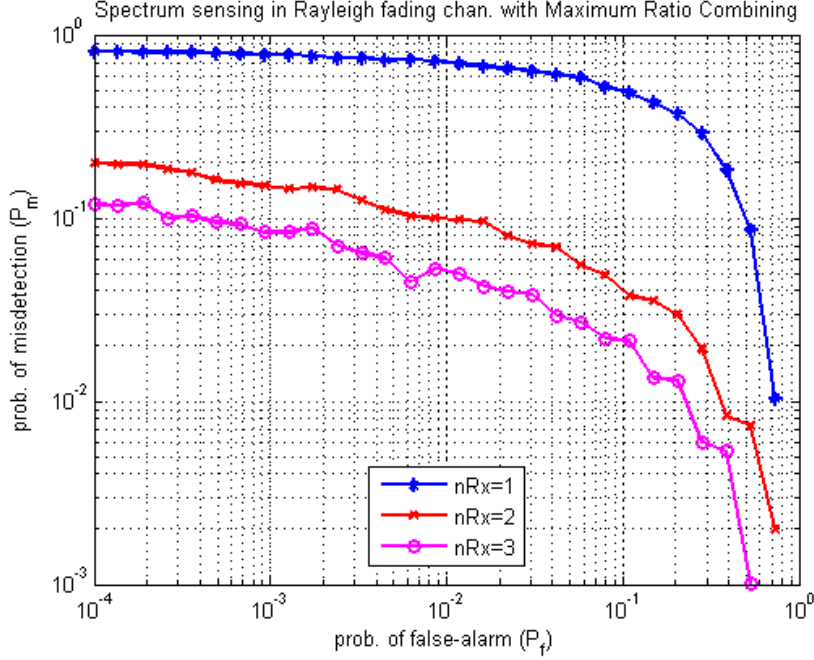
Simulation Results:Figure 4.2: P_f vs P_{md} by varying the no. of receive antennas

From the above Fig 4.1 and Fig 4.2, it is observed that the detection probability (P_d) for MRC is good compared to EGC.

4.2 Optimal Cooperative Spectrum Sensing

Let us consider CR network has M number of secondary users. The weighting co-operation for spectrum sensing in CR network has been schematically represented in Fig 4.3

The binary hypothesis test for SS at the instant k can be written as [6],

$$x_i(k) = \begin{cases} h_i s(k) + v_i(k) & H_1 \\ v_i(k) & H_0 \end{cases} \quad (4.13)$$

where signal radiated by the primary user (PU) is represented as $s(k)$ and signal received by i^{th} secondary user is denoted as $x_i(k)$. $s(k)$ is affected by the channel gain h_i due to which the radiated signal by the PU is altered. The

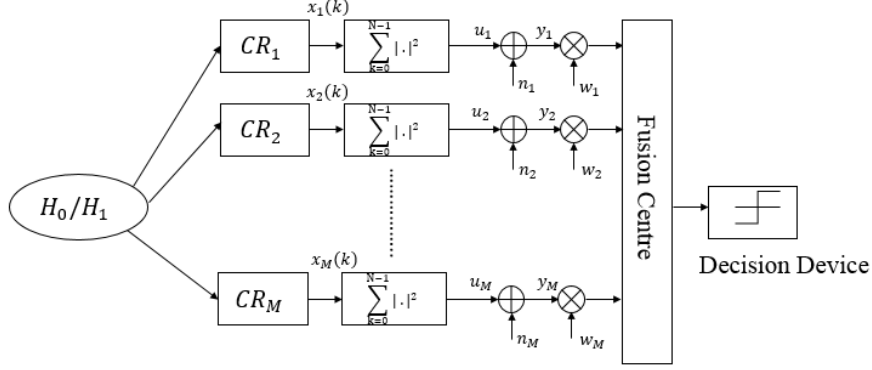

Figure 4.3: Schematic representation of weighting cooper. for SS in CR networks [6]

effect of channel h_i on $s(k)$ is assumed as constant during the detection period. Here the signal $s(k)$ is also distorted by the AWGN $v_i(k)$ with mean as zero. Here we take $s(k)$ and $v_i(k)$ does not depend on each other, i.e., $v_i(k) \sim \mathbb{N}(0, \sigma_i^2)$ and variances, $\sigma = [\sigma_1^2, \sigma_2^2, \dots, \sigma_M^2]^T$ [6].

As in Fig 4.3, the summary statistic u_i is measured by each secondary user over a detection period of N samples, i.e.,

$$u_i = \sum_{k=0}^{N-1} x_i(k)^2 \quad i = 1, 2, \dots, M \quad (4.14)$$

here N is calculated by the product of time-bandwidth.

Now the summary statistics u_i are passed to the fusion center through a control channel in an orthogonal manner which is denoted as

$$\underbrace{\begin{bmatrix} y_1 \\ y_2 \\ \cdot \\ \cdot \\ \cdot \\ y_M \end{bmatrix}}_y = \underbrace{\begin{bmatrix} u_1 \\ u_2 \\ \cdot \\ \cdot \\ \cdot \\ u_M \end{bmatrix}}_u + \underbrace{\begin{bmatrix} n_1 \\ n_2 \\ \cdot \\ \cdot \\ \cdot \\ n_M \end{bmatrix}}_n \quad (4.15)$$

where the channel noises n_i are zero-mean, spatially uncorrelated Gaussian variables with variances δ_i^2 ; the variances are collected into the vector form

$\delta = [\delta_1^2, \delta_2^2, \dots, \delta_M^2]^T$. The AWGN channel shown in (4.15) is validated by the assumptions we made on analog forwarding process and the moderate changing behavior of the channels between the SU's and the fusion centre. Here the assumption is made that the channel coherence time is more than the estimation period such that once the fusion centre has predicted the gains of the channel from the SU's, these channels could be considered as non varying AWGN channels [6].

The fusion centre calculates a global test statistic, y_c (4.24) from all the individual secondary user outputs y_i and the spectrum sensor employs y_c to make a global decision. This chapter deals with the design of optimal linear fusion rules at the fusion center to improve the detection performance as maximum as possible.

4.2.1 Local Sensing

First let us do local spectrum sensing at each and every SU's. Using energy detection the decision statistic of secondary user i is given by (4.14).

Central limit theorem states that if the number of samples N is very large, then the test statistics u_i are normally distributed with mean [6], which is given by Eq (4.16).

$$E_{u_i} = \begin{cases} N\sigma_i^2 & H_0 \\ (N + \eta_i)\sigma_i^2 & H_1 \end{cases} \quad (4.16)$$

where the local SNR at i^{th} SU is given by η_i

$$\eta_i = \frac{E_s h_i^2}{\sigma_i^2} \quad (4.17)$$

and

$$E_s = \sum_{k=0}^{N-1} |s(k)|^2 \quad (4.18)$$

and variance

$$Var(u_i) = \begin{cases} 2N\sigma_i^4 & H_0 \\ 2(N + 2\eta_i)\sigma_i^4 & H_1 \end{cases} \quad (4.19)$$

The decision statistic at each and every SU for a single-CR spectrum sensing method [6], is given by

$$\begin{array}{c} H_1 \\ u_i \geq \gamma_i \\ u_i < \gamma_i \\ H_0 \end{array} \quad i = 1, 2, \dots, M \quad (4.20)$$

where decision threshold is denoted as γ_i . Therefore, SU i have the probabilities of false alarm and detection [6]:

$$P_f^{(i)} = Pr(u_i > \gamma_i | H_0) = Q \left[\frac{\gamma_i - E(u_i | H_0)}{\sqrt{Var(u_i | H_0)}} \right] \quad (4.21)$$

and

$$P_d^{(i)} = Pr(u_i > \gamma_i | H_1) = Q \left[\frac{\gamma_i - E(u_i | H_1)}{\sqrt{Var(u_i | H_1)}} \right] \quad (4.22)$$

Spectrum sensing can be simply done by using a single CR, but suffers from either fading or shadowing. Hence accuracy can be improved by detecting the presence of primary detection using cooperation between CR's.

4.2.2 Global Decision

Under global decision multiple SU's are considered. The u_i is passed to the fusion centre directly through a fixed control channel. The Equation (4.15) tells that the received statistic y_i are distributed normally having means $E_{y_i} = E_{u_i}$ and variances [6]

$$Var(y_i) = \begin{cases} 2N\sigma_i^4 + \delta_i^2 & H_0 \\ 2(N + 2\eta_i)\sigma_i^4 + \delta_i^2 & H_1 \end{cases} \quad (4.23)$$

The global test statistic is computed after the reception of y_i at fusion centre by using Eq (4.24),

$$y_c = \sum_{i=1}^M w_i y_i = \mathbf{w}^T \mathbf{y} \quad (4.24)$$

where

$$\mathbf{w} = [w_1, w_2, \dots, w_M]^T, \quad w_i \geq 0 \quad (4.25)$$

The global spectrum detector can be controlled by using weight vector represented in Eq (4.25). Larger weighting coefficient is assigned to the CR which generates high SNR. Decreased weights should be assigned to the CR's or SU's which are getting deep fading or shadowing to decrease their negative effect to the decision fusion [6].

Linear combination of y_i are normal as the variables y_i are normal random variables. Accordingly, y_c has mean

$$\bar{y}_c = E_{y_c} = \begin{cases} N\sigma^T \mathbf{w} & H_0 \\ (N\sigma + E_s \mathbf{g})^T \mathbf{w} & H_1 \end{cases} \quad (4.26)$$

where

$$\mathbf{g} = [|h_1|^2, |h_2|^2, \dots, |h_M|^2]^T \quad (4.27)$$

represents the squared amplitudes of the channel gains, and variance

$$\begin{aligned} Var(y_c) &= E(y_c - \bar{y}_c)^2 \\ &= \mathbf{w}^T E[(y - \bar{y})(y - \bar{y})^T] \mathbf{w} \end{aligned} \quad (4.28)$$

The variances under different hypothesis are respectively given by

$$\begin{aligned} Var(y_c|H_0) &= \mathbf{w}^T E[(y - \bar{y}_{H_0})(y - \bar{y}_{H_0})^T | H_0] \mathbf{w} \\ &= \sum_{i=1}^M (2N\sigma_i^4 + \delta_i^2) w_i^2 \\ &= \mathbf{w}^T \Sigma_{H_0} \mathbf{w} \end{aligned} \quad (4.29)$$

with

$$\Sigma_{H_0} = 2N \text{diag}^2(\sigma) + \text{diag}(\delta) \quad (4.30)$$

and

$$\begin{aligned} \text{Var}(y_c|H_1) &= \mathbf{w}^T E \left[(y - \bar{y}_{H_1}) (y - \bar{y}_{H_1})^T | H_1 \right] \mathbf{w} \\ &= \sum_{i=1}^M (2N\sigma_i^4 + 4\eta_i\sigma_i^4 + \delta_i^2) w_i^2 \\ &= \mathbf{w}^T \Sigma_{H_1} \mathbf{w} \end{aligned} \quad (4.31)$$

with

$$\Sigma_{H_1} = 2N \text{diag}^2(\sigma) + \text{diag}(\delta) + 4E_s \text{diag}(\mathbf{g}) \text{diag}(\sigma) \quad (4.32)$$

Since Σ_{H_1} is diagonal and positive semi-definite, its square root can be represented as

$$\Sigma_{H_1}^{1/2} = \text{diag} \begin{bmatrix} \sqrt{2N\sigma_1^4 + 4E_s|h_1|^2\sigma_1^2 + \delta_1^2} \\ \sqrt{2N\sigma_2^4 + 4E_s|h_2|^2\sigma_2^2 + \delta_2^2} \\ \vdots \\ \sqrt{2N\sigma_M^4 + 4E_s|h_M|^2\sigma_M^2 + \delta_M^2} \end{bmatrix} \quad (4.33)$$

Considering the linear rule, the test statistic at the fusion centre is given by,

$$\begin{aligned} &H_1 \\ &\geq \\ &y_c < \gamma_c \\ &< \\ &H_0 \end{aligned} \quad (4.34)$$

The performance of the proposed cooperative spectrum detection technique can be computed as [6]. The probability of false alarm (P_f) and Probability of detection (P_d) under global decision is given as,

$$P_f = Q \left[\frac{\gamma_c - N\sigma^T \mathbf{w}}{\sqrt{\mathbf{w}^T \Sigma_{H_0} \mathbf{w}}} \right] \quad (4.35)$$

and

$$P_d = Q \left[\frac{\gamma_c - (N\sigma + E_s \mathbf{g})^T \mathbf{w}}{\sqrt{\mathbf{w}^T \Sigma_{H_1} \mathbf{w}}} \right] \quad (4.36)$$

Optimization of the Modified Deflection Coefficient:

The optimal weights [6], [36] are obtained from the equations (4.37) and (4.38), which gives better Probability of detection (P_d).

$$\mathbf{w}' = \Sigma_{H_1}^{-1/2} \mathbf{w} \quad (4.37)$$

The optimal weight equation of the Modified Deflection Coefficient is,

$$\mathbf{w}_{opt} = \frac{\Sigma_{H_1}^{-1/2} \mathbf{w}'}{\left\| \Sigma_{H_1}^{-1/2} \mathbf{w}' \right\|_2} \quad (4.38)$$

Simulation Results:

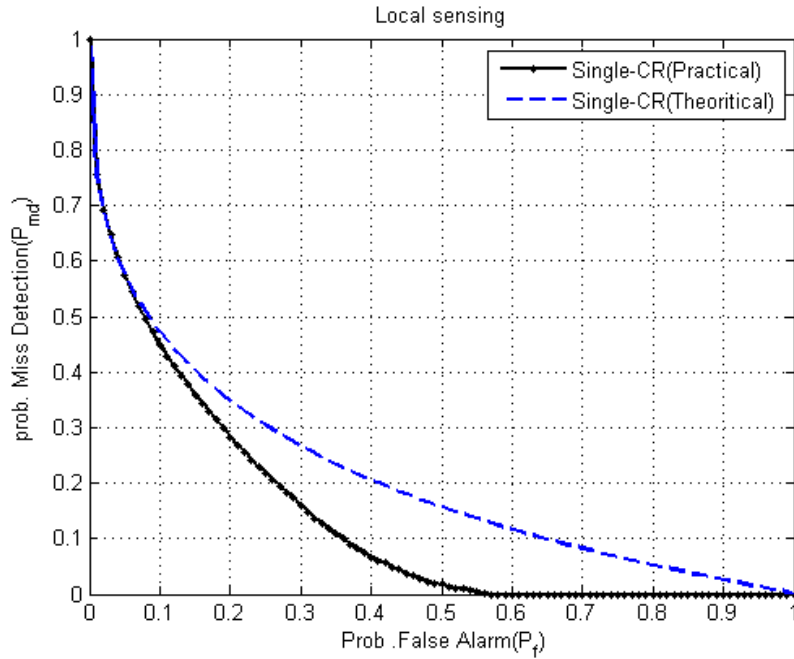
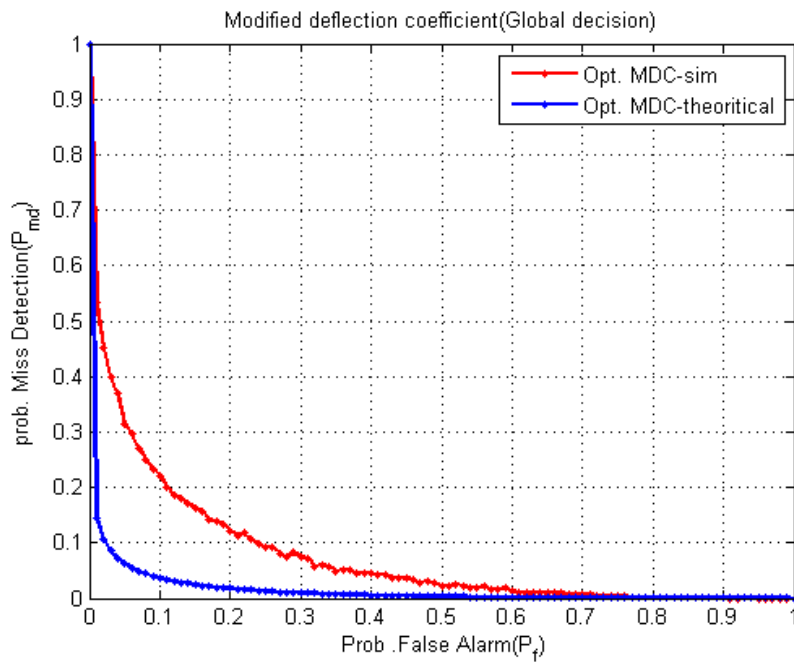

Figure 4.4: P_f vs P_{md}

From Figures 4.4 4.5, it is observed that the Probability of Misdetection (P_{md}) of a single user at probability of false alarm, $P_f=0.1$ is 0.48 which implies that the Probability of detection, $P_d = 1 - P_{md}=0.52$ where as for multi-user using Modified Deflection Coefficient the Probability of Misdetection (P_{md}) at probability of false alarm, $P_f=0.1$ is 0.21 which implies that the Probability

Figure 4.5: P_f vs P_{md}

of detection, $P_d = 1 - P_{md} = 0.79$. Therefore, the performance of multi-user using Modified Deflection Coefficient is better than the single user.

5

Conclusion

5.1 Conclusion

After observing the performances of Transmitter detection techniques like Energy detection (ED), Combination of Maximum Minimum Eigen-value based detection and Cyclostationary detection (CSD) techniques, it is clear that the performance of Energy detection is poor at low SNR, good at high SNR and complexity is less whereas the performance of CMME and CSD is giving better Probability of detection (P_d) at low SNR and the implementation of these two techniques is complex compared to Energy detection technique (ED).

The Two Stage Spectrum Sensing using ED and CSD motivated to implement Two Stage Spectrum Sensing using ED and CMME by taking both BPSK and DVB-T signal because from the simulation results of CSD and CMME, it is observed that the performance of CMME is better at low SNR compared to CSD. In this technique, the channel is tested by using energy detection technique (ED) in the first stage. If the decision is more than the threshold Φ_{ED} , then the channel is decided as occupied, otherwise the received signal is again sensed by using the second stage i.e., CMME technique. If the decision is more than

the threshold γ_2 , then the channel is considered as occupied else it is empty. The individual performance of each technique is compared with the two stage technique using ED and CMME. The comparison between two stage SS technique using ED and CSD and two stage SS technique using ED and CMME is observed. The Two Stage SS technique using ED and CMME is giving better Probability of detection than the Two Stage SS using ED and CSD techniques.

Under Cooperative Spectrum sensing the performance of Equal Gain Combining (EGC) and Maximal Ratio Combining (MRC) is observed. From the simulation results, it is clear that the Probability of detection (P_d) for Maximal Ratio Combining (MRC) is good compared to Equal Gain Combining (EGC).

Optimal linear cooperation framework for ss is observed to detect the weak primary signal accurately. Global decision is made by using Modified Deflection Coefficient (MDC) method. The performance of single user and global decision using MDC is observed. From the simulation results, it is clear that the Probability of detection (P_d) for global decision using MDC is better compared to single user.

5.2 Scope of Future work

- Performance analysis of two stage spectrum sensing technique based on timing can be carried out.
- CMME can be used to estimate the noise variance and fed it back to ED to enhance the performance of first stage in two stage spectrum sensing technique. Indirectly making the dual stage as full blind and self-adaptive.
- Real-time measured data can be used to check the detection performance.
- Under Optimal Cooperative Spectrum Sensing, the weights can be optimized by using evolutionary optimization techniques like Particle Swarm Optimization (PSO), Infeasibility Driven Evolutionary Algorithm (IDEA) etc to obtain better Probability of detection (P_d).

Bibliography

- [1] H. Arslan, *Cognitive radio, software defined radio, and adaptive wireless systems*. Springer, 2007, vol. 10.
- [2] N. Yadav and S. Rathi, “Spectrum sensing techniques: Research, challenge and limitations 1,” 2011.
- [3] “Tv white space.” [Online]. Available: <https://spectrumbridge.com/tv-white-space/>
- [4] L. Perera and H. Herath, “Review of spectrum sensing in cognitive radio,” in *Industrial and Information Systems (ICIIS), 2011 6th IEEE International Conference on*. IEEE, 2011, pp. 7–12.
- [5] Y.-C. Liang, Y. Zeng, E. C. Peh, and A. T. Hoang, “Sensing-throughput tradeoff for cognitive radio networks,” *Wireless Communications, IEEE Transactions on*, vol. 7, no. 4, pp. 1326–1337, 2008.
- [6] Z. Quan, S. Cui, and A. H. Sayed, “Optimal linear cooperation for spectrum sensing in cognitive radio networks,” *Selected Topics in Signal Processing, IEEE Journal of*, vol. 2, no. 1, pp. 28–40, 2008.
- [7] D. Cabric, S. M. Mishra, and R. W. Brodersen, “Implementation issues in spectrum sensing for cognitive radios,” in *Signals, systems and computers, 2004. Conference record of the thirty-eighth Asilomar conference on*, vol. 1. IEEE, 2004, pp. 772–776.

- [8] V. Gonçalves and S. Pollin, “The value of sensing for tv white spaces,” in *New Frontiers in Dynamic Spectrum Access Networks (DySPAN), 2011 IEEE Symposium on*. IEEE, 2011, pp. 231–241.
- [9] S. Maleki, A. Pandharipande, and G. Leus, “Two-stage spectrum sensing for cognitive radios,” in *Acoustics Speech and Signal Processing (ICASSP), 2010 IEEE International Conference on*. IEEE, 2010, pp. 2946–2949.
- [10] M. Yang, J. An, X. Bu, and L. Sun, “An improved eigenvalue-based algorithm for cooperative spectrum sensing,” in *Wireless Communications Networking and Mobile Computing (WiCOM), 2010 6th International Conference on*. IEEE, 2010, pp. 1–4.
- [11] H. Liu and W. Chen, “A robust detection algorithm based on maximum-minimum eigenvalue for cognitive radio,” in *Wireless Communications, Networking and Mobile Computing (WiCOM), 2012 8th International Conference on*. IEEE, 2012, pp. 1–4.
- [12] A. Satheesh, S. Aswini, S. Lekshmi, S. Sagar, and H. Kumar, “Spectrum sensing techniques a comparison between energy detector and cyclostationarity detector,” in *2013 International Conference on Control Communication and Computing (ICCC)*.
- [13] M. Li and L. Li, “Performance analysis and optimization of cooperative spectrum sensing based on soft combination,” in *Wireless Communications, Networking and Mobile Computing (WiCOM), 2011 7th International Conference on*. IEEE, 2011, pp. 1–4.
- [14] T. Cui, F. Gao, and A. Nallanathan, “Optimization of cooperative spectrum sensing in cognitive radio,” *Vehicular Technology, IEEE Transactions on*, vol. 60, no. 4, pp. 1578–1589, 2011.
- [15] A. Bagwari and G. S. Tomar, “Multiple energy detection vs cyclostationary feature detection spectrum sensing technique,” in *Communication Systems and Network Technologies (CSNT), 2014 Fourth International Conference on*. IEEE, 2014, pp. 178–181.

- [16] K. Chhabra, G. Mahendru, and P. Banerjee, "Effect of dynamic threshold & noise uncertainty in energy detection spectrum sensing technique for cognitive radio systems," in *Signal Processing and Integrated Networks (SPIN), 2014 International Conference on*. IEEE, 2014, pp. 377–361.
- [17] J. Dalai and S. K. Patra, "Spectrum sensing for wlan and wimax using energy detection technique," in *Emerging Trends in Computing, Communication and Nanotechnology (ICE-CCN), 2013 International Conference on*. IEEE, 2013, pp. 620–624.
- [18] J. Mishra, D. K. Barik, and C. M. K. Swain, "Cyclostationary based spectrum sensing in cognitive radio: Windowing approach," *a a*, vol. 2, no. 2, p. 2.
- [19] J. Chen, A. Gibson, and J. Zafar, "Cyclostationary spectrum detection in cognitive radios," 2008.
- [20] S. Narieda and T. Kageyama, "Simple spectrum sensing techniques based on cyclostationarity detection in cognitive radio networks," *Electronics Letters*, vol. 49, no. 17, pp. 1108–1109, 2013.
- [21] J. K. Tugnait and G. Huang, "Cyclic autocorrelation based spectrum sensing in colored gaussian noise," in *Wireless Communications and Networking Conference (WCNC), 2012 IEEE*. IEEE, 2012, pp. 731–736.
- [22] Z. Ye, J. Grosspietsch, and G. Memik, "Spectrum sensing using cyclostationary spectrum density for cognitive radios," in *Signal Processing Systems, 2007 IEEE Workshop on*. IEEE, 2007, pp. 1–6.
- [23] H. Li, "Cyclostationary feature based quickest spectrum sensing in cognitive radio systems," in *Vehicular Technology Conference Fall (VTC 2010-Fall), 2010 IEEE 72nd*. IEEE, 2010, pp. 1–5.
- [24] Y. Zeng, C. L. Koh, and Y.-C. Liang, "Maximum eigenvalue detection: theory and application," in *Communications, 2008. ICC'08. IEEE International Conference on*. IEEE, 2008, pp. 4160–4164.

- [25] Y. Zeng and Y.-C. Liang, “Maximum-minimum eigenvalue detection for cognitive radio,” in *Personal, Indoor and Mobile Radio Communications, 2007. PIMRC 2007. IEEE 18th International Symposium on*. IEEE, 2007, pp. 1–5.
- [26] L. S. Cardoso, M. Debbah, P. Bianchi, and J. Najim, “Cooperative spectrum sensing using random matrix theory,” in *Wireless Pervasive Computing, 2008. ISWPC 2008. 3rd International Symposium on*. IEEE, 2008, pp. 334–338.
- [27] F. Liu, H. Chen, L. Xie, and K. Wang, “Maximum-minimum eigenvalue detection-based method to mitigate the effect of the puea in cognitive radio networks,” in *Wireless Communications and Signal Processing (WCSP), 2011 International Conference on*. IEEE, 2011, pp. 1–5.
- [28] N. Pillay and H. Xu, “Blind eigenvalue-based spectrum sensing for cognitive radio networks,” *IET communications*, vol. 6, no. 11, pp. 1388–1396, 2012.
- [29] Y. He, T. Ratnarajah, J. Xue, E. H. Yousif, and M. Sellathurai, “Optimal decision threshold for eigenvalue-based spectrum sensing techniques,” in *Acoustics, Speech and Signal Processing (ICASSP), 2014 IEEE International Conference on*. IEEE, 2014, pp. 7734–7738.
- [30] S. Deng, Y. Ji, F. Zhou, L. Du, B. Wang, and W. Wang, “Optimal threshold for dual-stage spectrum sensing in cognitive radio,” in *Communications and Networking in China (CHINACOM), 2013 8th International ICST Conference on*. IEEE, 2013, pp. 963–968.
- [31] M.-G. Di Benedetto and F. Bader, *Cognitive Communication and Cooperative HetNet Coexistence*. Springer, 2013.
- [32] E. Zhao, Z. Yong-hui, and Y. Wu, “A sequential cooperative spectrum sensing algorithm in cognitive radio,” in *Computing, Measurement, Control and Sensor Network (CMCSN), 2012 International Conference on*. IEEE, 2012, pp. 17–20.

- [33] I. F. Akyildiz, B. F. Lo, and R. Balakrishnan, “Cooperative spectrum sensing in cognitive radio networks: A survey,” *Physical Communication*, vol. 4, no. 1, pp. 40–62, 2011.
- [34] A. Ghasemi and E. S. Sousa, “Opportunistic spectrum access in fading channels through collaborative sensing,” *Journal of communications*, vol. 2, no. 2, pp. 71–82, 2007.
- [35] —, “Collaborative spectrum sensing for opportunistic access in fading environments,” in *New Frontiers in Dynamic Spectrum Access Networks, 2005. DySPAN 2005. 2005 First IEEE International Symposium on*. IEEE, 2005, pp. 131–136.
- [36] L. Chuan-qing and W. Zhi-ming, “Adaptive weighted algorithm of cooperative spectrum sensing in cognitive radio networks,” 2011.

Publication

- Naresh G, S M Hiremath, S K Patra, “**Two Stage spectrum Sensing for Cognitive Radio using CMME,**” *4th IEEE International Conference on Communication and Signal Processing (ICCSP15)*, APR 2015 (Presented).