

SENSOR MODELING AND LINEARIZATION USING ARTIFICIAL NEURAL NETWORK TECHNIQUE

A Thesis submitted in partial fulfillment of the requirements for the degree of

Master of Technology

in

Electronics and Communication Engineering

Specialization: Electronics and Instrumentation Engineering

by

SUNIL RATHOD

Roll No.: 213EC3227

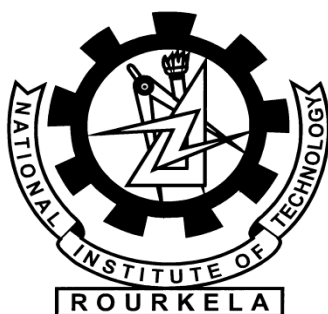

Department of Electronics and Communication Engineering

National Institute of Technology, Rourkela

Odisha- 769008, India

May 2015

SENSOR MODELING AND LINEARIZATION USING ARTIFICIAL NEURAL NETWORK TECHNIQUE

A Thesis submitted in partial fulfillment of the requirements for the degree of

Master of Technology

in

Electronics and Communication Engineering

Specialization: Electronics and Instrumentation Engineering

by

SUNIL RATHOD

Roll No.: 213EC3227

Under the Supervision of

Prof. KAMALAKANTA MAHAPATRA



Department of Electronics and Communication Engineering

National Institute of Technology, Rourkela

Odisha- 769008, India

May 2015



Dept. of Electronics and Communication Engineering
National Institute of Technology, Rourkela
Odisha- 769008, India

CERTIFICATE

This is to certify that the work in the thesis entitled “**SENSOR MODELING AND LINEARIZATION USING ARTIFICIAL NEURAL NETWORK TECHNIQUE**” by **Mr. SUNIL RATHOD**, Roll No. **213EC3227** is a record of an original and authentic research work carried out by him during the session 2014 – 2015 under my supervision and guidance in partial fulfillment of the requirements for the award of the degree of Master of Technology in Electronics and Communication Engineering (Electronics and Instrumentation), National Institute of Technology, Rourkela.

To the best of my knowledge, the work in this thesis has not been submitted to any other University / Institute for the award of any degree or diploma.

Prof. Kamalakanta Mahapatra

Date:

Dept. of Electronics and Communication Engg.

Place: Rourkela

National Institute of Technology, Rourkela

DEDICATED TO
MY TEACHERS,
FRIENDS &
MY PARENTS

ACKNOWLEDGEMENTS

I would like to express my deep sense of respect and gratitude towards my supervisor and guide **Prof. Kamalakanta Mahapatra** who has been a guiding force behind this work. I am highly obliged and grateful for his excellent guidance, endless encouragement and cooperation extended to me right from the onset of this task till its successful completion. I consider myself fortunate to work under such a wonderful person.

I am very thankful to Prof. T.K. Dan and Prof. U.C. Pati for their valuable suggestions during the reviews of this work. I am also thankful to Prof. A.K. Swain, Prof. D.P. Acharya and Prof. S.K. Patra for teaching me and helping me in every aspect throughout my M.Tech. Course duration.

My sincere thanks to PhD Sir Mr. Subhransu Padhee for his encouragements, suggestions and feedbacks which have always motivated me. I would like to thank my friends and classmates, in particular, for the fun and enjoyment that we have shared for the last two years of my stay in NIT Rourkela. The stay at NIT Rourkela would not have been so wonderful without them.

I am indebted to my parents for their love, affection and sacrifice. Their unconditional support and encouragement has always been a guiding force.

SUNIL RATHOD

ABSTRACT

Many Sensors show a nonlinear relationship between their input and output. Sometimes the reason for nonlinearity is inherent and sometimes it is due to the changes in the environmental parameters like temperature and humidity. Ageing is also responsible for the nonlinearity of sensors. Due to the presence of nonlinearity, it becomes very difficult to directly read the sensor over its whole sensing range. The accuracy of the device is affected if it is used in its full input range. Hence it is very much necessary to study the problem of nonlinearity present in sensors and to solve it. Thermistor and thermocouple are the temperature sensors that exhibit nonlinear characteristics. Thermistor is the most nonlinear device but thermocouple is linear if operated in a specific operating temperatures. Thermocouple shows nonlinearity if operated in its entire operating range.

The nonlinearity of a sensor can be compensated by designing an inverse model of the sensor and connecting it in series with the sensor. This enables the digital readout of the output of the sensor. So the inverse models of these temperature sensors are designed and connected in series with them, so that the associated nonlinearity can be compensated and the output can be read digitally. The neural network technique seems to be an ideal technique for designing the inverse model of such sensors. Also, a direct model of such sensors is also designed which can be used for calibrating inputs and for fault detection. A technique for linearizing the output of the sensor without using inverse modeling is also discussed.

CONTENTS

ACKNOWLEDGEMENTS	i
ABSTRACT	ii
CONTENTS	iii
LIST OF FIGURES	v
1 INTRODUCTION	2
1.1 Static Characteristics of a sensor	2
1.1.1 Accuracy.....	2
1.1.2 Precision	2
1.1.3 Error.....	3
1.1.4 Correction	3
1.1.5 Uncertainty	4
1.1.6 Hysteresis	4
1.1.7 Repeatability.....	4
1.1.8 Sensitivity	5
1.1.9 Resolution.....	5
1.1.10 Linearity	6
1.2 Dynamic Characteristics of a sensor	7
1.3 Motivation	7
1.4 Literature Review	8
2 ARTIFICIAL NEURAL NETWORK TECHNIQUE	12
2.1 Properties of ANN.....	12
2.1.1 Power.....	13
2.1.2 Ease of use.....	13
2.1.3 Nonlinearity	13
2.1.4 Adaptivity	13
2.1.5 VLSI Implementation	13
2.2 Model of a neuron	14
2.3 Multilayer Perceptron (MLP)	17
2.4 Back-propagation Algorithm.....	19
2.5 Application of Neural Network	21
2.5.1 System Identification.....	22

2.5.2	Inverse Modeling.....	23
3	DIRECT MODELING AND INVERSE MODELING OF A THERMISTOR.....	25
3.1	Thermistor	25
3.1.1	Basic Operation	25
3.1.2	Thermistor Classification	25
3.1.3	Thermistor Mathematical Models	26
3.1.4	Self Heating Effect of thermistor.....	29
3.2	Voltage Divider Circuit	29
3.3	Development of Direct Model and Inverse Model of Thermistor	30
3.3.1	Direct Modeling.....	30
3.3.2	Inverse Modeling.....	31
3.4	Simulation Results.....	31
3.4.1	Neural network based direct modeling of thermistor	32
3.4.2	Neural network based inverse modeling of thermistor.....	33
4	DIRECT MODELLING AND INVERSE MODELLING OF A THERMOCOUPLE	35
4.1	Thermocouple.....	35
4.1.1	Principle of operation	35
4.1.2	Polynomial Model of thermocouple	36
4.1.3	Thermocouple Measurement	36
4.1.4	Ageing of thermocouple	37
4.1.5	Types of thermocouple	38
4.2	Development of Direct Model and Inverse Model of Thermocouple	39
4.2.1	Direct Modeling.....	40
4.2.2	Inverse Modeling.....	41
4.3	Simulation Results.....	41
4.3.1	Neural network based direct modeling of thermocouple.....	41
4.3.2	Neural network based inverse modeling of thermocouple	43
5	NEURAL NETWORK BASED SENSOR LINEARIZATION.....	45
5.1	Simulation Results.....	46
6	CONCLUSION.....	48
	BIBLIOGRAPHY	49

LIST OF FIGURES

Fig. 1. 1 : Hysteresis Curve	4
Fig. 1. 2 : Nonlinear characteristic of a thermistor	6
Fig. 2. 1 : Model of Neuron	14
Fig. 2. 2 : Threshold Activation Function	15
Fig. 2. 3 : Signum Activation Function	16
Fig. 2. 4 : Sigmoid Activation Function	16
Fig. 2. 5 : Hyperbolic Tangent Activation Function.....	17
Fig. 2. 6 : Structure of Multilayer Perceptron.....	18
Fig. 2. 7 : Two basic signal flows in a Multilayer Perceptron.....	19
Fig. 2. 8 : Neural Network employing Back-propagation Algorithm.....	20
Fig. 2. 9 : Block diagram of System Identification	22
Fig. 2. 10 : Block diagram of Inverse System Modeling.....	23
Fig. 3.1 : Characteristic of a thermistor	28
Fig. 3. 2 : Voltage Divider Circuit for Resistance to Voltage Conversion of a thermistor	29
Fig. 3. 3 : A scheme for direct modeling of Thermistor with VDC using neural network based model..	30
Fig. 3. 4 : A scheme for inverse modeling of Thermistor with VDC using neural network based model	31
Fig. 3.5 : Plot of Actual and Estimated Output of thermistor sensor.....	32
Fig. 3. 6 : Plots of forward, inverse and overall characteristics of the thermistor	33
Fig. 4. 1 : Thermocouple measurement scheme	37
Fig. 4. 2 : Characteristic functions of different thermocouple types	38
Fig. 4. 3 : A scheme for direct modeling of Thermocouple using neural network based model.....	40
Fig. 4. 4 : A scheme for inverse modeling of Thermocouple using neural network based model	41
Fig. 4. 5 : Plot of Actual and Estimated Output of thermocouple sensor	42
Fig. 4. 6 : Plots of forward, inverse and overall characteristics of the thermocouple	43
Fig. 5. 1 : Neural Network based Linearization (a) Training and (b) Testing	45
Fig. 5. 2 : Characteristics of the sensor before and after linearization suing neural network.....	46

1

INTRODUCTION

1 INTRODUCTION

The devices which convert the physical input quantities into electrical or any different physical quantity for the purpose of measurement are known as sensors. The Instrument Society of America has defined the sensor as “*a device which provides a usable output in response to a specified measurand*”. Sensors and transducers are the basic devices needed to sense and convert the physical parameters to a convenient form. The convenient form of the measurement is, most commonly, an electrical signal, which has many advantages compared to other forms such as optical, fluidic and mechanical. A sensor is unique while the transducer is composite. A sensor structure gets more physically attached to the environment under operation than the transducer.

1.1 Static Characteristics of a sensor

Static characteristics are related to the amplitude of the response or the output of the system when the measurand or input does not vary with time. The important static characteristics are discussed below.

1.1.1 Accuracy

Accuracy can be defined as the capacity of an instrument system that gives a result that is near to the true or ideal value. The true or ideal value is the standard against which the system can be calibrated. The measured value of most systems fails to represent the true value either due to the effects inherent to the system or other interfering inputs such as temperature, humidity and vibration. The accuracy of the system given by

$$A = 1 - \left| \frac{Y - X}{Y} \right| \quad (1.1)$$

where

X is the measured value

Y is the true or ideal value

Accuracy is generally expressed in percentage form as

$$\%A = A \times 100 \quad (1.2)$$

1.1.2 Precision

Precision is the characteristics of a measuring system that indicates how closely it repeats the same value of the outputs when the same inputs are applied to the system under the same operating and

environmental conditions. Although there is very less likelihood that the output response is exactly repeated, the closeness of repetition can be considered by taking a cluster of repeating points. The degree of this precision is expressed as the probability of a large number of readings falling within the cluster of closeness. However such closeness may not have closeness to the true value. Hence an accurate system is also precise but a precise system may not be accurate.

Let us take N readings of the measurements of which the mean value is

$$\bar{X} = \frac{1}{N} \sum_{n=1}^N X_n \quad N = \text{Number of data} \quad (1.3)$$

The precision of measurement is given by

$$P = 1 - \left| \frac{X_n - \bar{X}}{\bar{X}} \right| \quad (1.4)$$

1.1.3 Error

The deviation of the output or response of the system from true or ideal value is defined as the error of the system. The difference of the measured value and the true value is taken to calculate error. This is called absolute error. Sometimes, the error is calculated as a percentage of the full scale range or with respect to the span of the instrument. Therefore the error is expressed is

$$\varepsilon = X - Y \quad (1.5)$$

and

$$\% \varepsilon = \frac{X - Y}{Y_{FS}} \times 100 \quad (1.6)$$

where, Y_{FS} = true or ideal full scale value.

1.1.4 Correction

During the calibration of the instrument, the error has to be compensated using a calibrating circuit. The correction is the value to be added with the measured value to get the true value.

Hence the correction can be expressed as

$$\text{Correction} = Y - X = -\varepsilon \quad (1.7)$$

Depending on the polarity of deviation from the true value, the correction can be either positive or negative.

1.1.5 Uncertainty

Uncertainty is a term similar to error, which is used to express the deviation of the instrument from the actual value. It is the range of the deviation of the measured value from the true value. Uncertainty is also alternatively defined as a limiting error and expressed as a percentage of full scale reading.

1.1.6 Hysteresis

Many sensors with primary sensing devices made of elastic members show a difference between the two output readings for the same input, depending on the direction of successive input values either increasing or decreasing. This difference in output values is known as hysteresis. Hysteresis is a characteristic of not only mechanical or magnetic elements but also of many chemical and biochemical devices. A ferromagnetic material shows hysteresis effect upon magnetization and subsequent demagnetization. Many chemical sensors upon being exposed to chemicals get their sensitivity deformed and show a hysteresis effect.

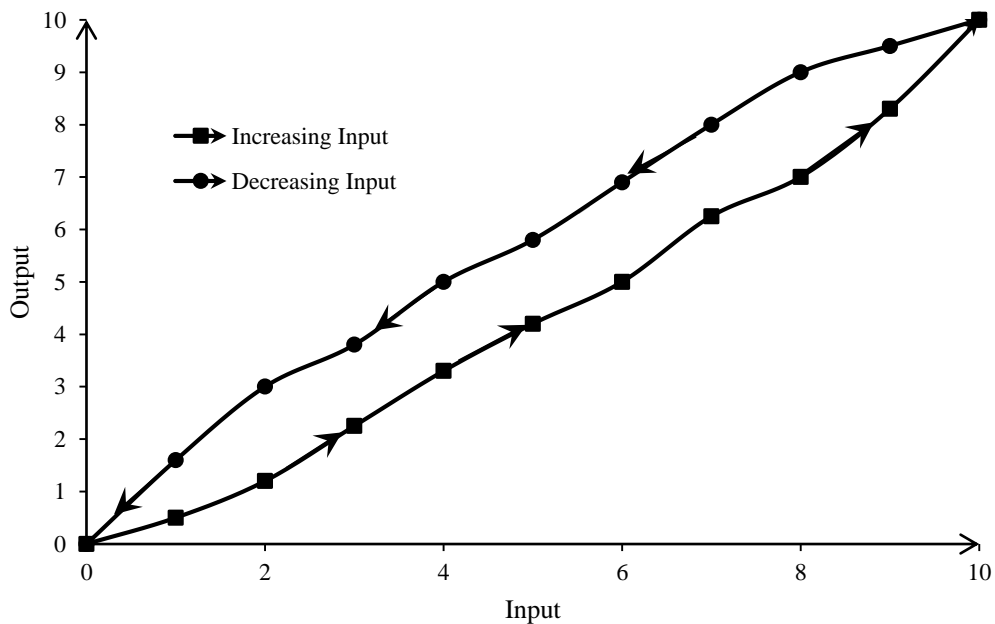

Fig. 1. 1 Hysteresis Curve

1.1.7 Repeatability

Repeatability of an instrument signifies the degree of closeness of a set of measurements for the same input obtained by the same observer with the same method and apparatus under the same

operating conditions, but for a short duration of operation. Alternatively, it can be defined as it is the degree of conformity by which a set of reading is produced again and again for a particular value of input. It must be noted that the surrounding conditions should be same during the entire process.

1.1.8 Sensitivity

When a measuring instrument is used to measure an unknown quantity x , we need to know how the instrument relates the amplitude of input x with the amplitude of output or response y . This input-output- relationship is called sensitivity. Quantitatively, the sensitivity at any measuring point i is given by the slope

$$S_i = \frac{dy_i}{dx_i} \quad (1.8)$$

where x_i and y_i are the input and output at the measuring point i . It is desirable that a sensor has a constant sensitivity so that

$$\frac{dy_i}{dx_i} = K \quad \text{for } i = 1, 2, 3, \dots, m \quad (1.9)$$

where m is the measuring point of the highest operating range.

1.1.9 Resolution

A measuring instrument produces the smallest output quantity on application of smallest input. The smallest input for which the system produces the detectable output is called its resolution. The resolution is mostly a characteristic inherent to the measuring system that depends on its geometry or structural factors.

1.1.10 Linearity

The measuring instruments possess some undesirable characteristics due to which the actual output deviates from true or ideal values. The causes of deviation are various, including the inherent design characteristics and interfering inputs. Many instruments show a typical deviation from a trend of outputs even without interfering inputs making the system nonlinear. Such a characteristic of a measuring system is essential for calibrating the instrument by adopting various linearization techniques. In fact, when the sensitivity is constant over the operating range, the calibration characteristic is a straight line either passing through the origin or intercepting any one of the axis. When the sensitivity changes or does not remain constant over the operating range, the instrument is said to be non-linear. Linearity is a quantity that denotes the maximum deviation of the output from the true value as the percentage of the true value. The lesser this value, higher is the linearity.

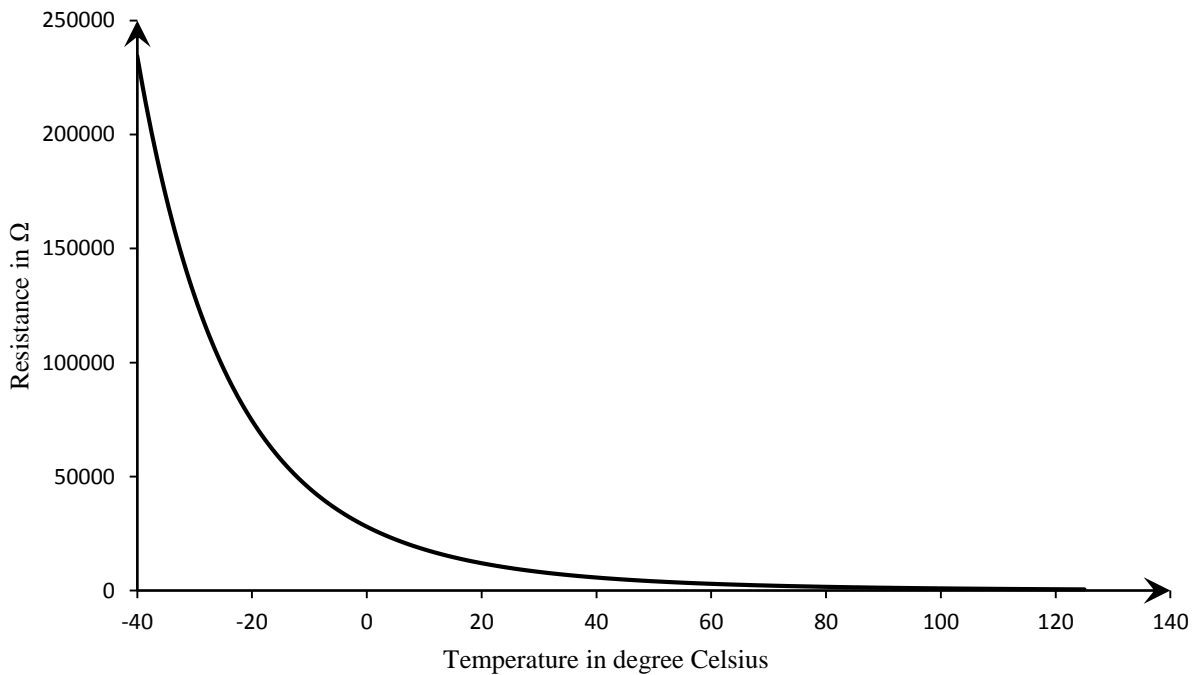

Fig. 1. 2 Nonlinear characteristic of a thermistor

1.2 Dynamic Characteristics of a sensor

When the energy storing elements are present in a system then the sensors show dynamic behavior for a time varying input than a time-invariant input. The dynamic behavior of these systems depends on their own characteristics as well as the dynamic characteristics of the input signal.

Different types of time varying signals are employed for a measuring system. But the dynamic characteristics of the measuring system are explained with respect to few common input signals such as step and ramp signals.

1.3 Motivation

The sensors shows nonlinear relationship between its input and output which limits their dynamic range. It becomes very difficult to read the output digitally over a whole input range of the sensor. So it is a challenging task to design and implement sensors which are free from the problem of nonlinearity associated with them. Also the accuracy in measurement is affected greatly due to ageing of the sensor and environmental parameters like temperature and humidity.

Thermistor and thermocouple are such sensors that exhibit nonlinear characteristics. The nonlinearity of a sensor can be compensated by designing an inverse model of the sensor and connecting it in series with it. This enables the digital readout of the output of the sensor. Also, a direct model of such sensors can be designed for the purpose calibrating inputs and for fault detection. Apart from developing an inverse model, a sensor can be linearized directly using neural networks.

So, the problems associated with the nonlinearity of the sensors along with the variations in nonlinearity with environmental changes motivated in the areas of modeling and linearization of the sensors.

1.4 Literature Review

- I. D. Patranabis, S. Ghosh, C. Bakshi; “Linearizing Transducer Characteristics”.

In this paper [1], the practical transducers are categorized into two types according to the relationship between their inputs and outputs. Type I is the one whose characteristics is exponentially rising whereas Type II is having characteristic that is exponentially decaying. Transducers with Type I characteristics can be easily linearized using logarithmic converters but Type II requires additional inverting ways so that it can be linearized. Although advantages of digital linearizing methods are given, the analog linearization schemes are given to linearize the transducer in a broad manner particularly of thermistors. Linearization scheme is developed for a thermistor using a log converter and an FET inverter. The error produced by this scheme are in the acceptable limits. In the end, it is concluded that the analog schemes of linearization are more suitable in the applications requiring wide range of operation. The digital scheme, however, leads to error which are unacceptable. The digital schemes such as look-up table techniques are expected to achieve the desired goal of linearization.

- II. N. Medrano-Marqués, R. del-Hoyo-Alonso, B. Martín-del-Brío, “A Thermocouple Model Based on Neural Networks”.

The classical thermocouple models consist of a set of polynomial expressions reproducing their behavior in different temperature ranges. In this paper [2] a new single model covering the whole sensing range of the thermocouple is presented. The model is developed using a neural network which reproduces the sensor behavior in the operating span of the thermocouple. To make a thermocouple model, a 1-3-3-1 multilayer perceptron is selected and the activation function $\tanh(x)$ is used as a nonlinear differentiable function. The learning data for a J-type thermocouple is obtained from the National Institute of Standards and Technology (NIST) tables. The developed model for a J-type thermocouple covers the whole sensor span (-200 to 1200 deg. C). The neural model and the classical model of the thermocouple are compared. The neural model yields error similar to that of the classical polynomial model. It has been concluded that the model structure depends on the thermocouple type in case of polynomial model but it remains the same for every type of thermocouple in neural model.

III. N. Medrano-Marqués, B. Martín-del-Brío, “Sensor Linearization with Neural Networks”.

In this paper [3], the linear range of an arbitrary sensor is extended. Here the nonlinear sensor response is considered as input and desired linear response is the output. The proposed procedure is implemented using a negative temperature coefficient resistor commonly known as thermistor. A thermistor is placed in a resistive divider circuit for the conversion of resistance into temperature. There is a nonlinear relationship between the voltage obtained from the voltage divider circuit and the temperature sensed by the thermistor. The difference between the voltage divider output and the ideal linear output is the target of the network. The neural network in the form of multilayer perceptron is having two nonlinear hidden nodes. The implementation of the neural network for the linearization is done in a low resolution microprocessor. For this the linear approximation of the tan sigmoid activation function is explained.

IV. M. Attari, F. Boudema, M. Heniche; “An Artificial Neural Network to linearize a G (Tungsten vs. Tungsten 26% Rhenium) Thermocouple characteristic in the range of zero to 2000 °C”.

In this paper [4] an alternative method for correcting the linearity of a sensor is proposed. In this paper design and behavior of a neural network is used to linearize the nonlinear characteristics of a G type thermocouple whose operating range is from 0 to 2000 °C. The application of interpolation method is also discussed to linearize the non-linearity of such sensors. The learning algorithms used for adjusting the weights of the neural network are backpropagation algorithm and random optimization algorithm. After the neural network is trained, it performs as a neural linearizer to produce temperature which is the physical variable to be measured from the thermocouple output voltage. A comparison is made for the accuracy of this method with the interpolation method.

1.5 Overview of Thesis

This thesis carries out the modeling of thermistor and thermocouple using the neural network techniques. Also the linearization of thermistor is carried out using neural networks. The Chapter 1 provides the introduction to the sensors along with their characteristics. The Chapter 2 provides the basics of neural network and the training methods to train the neural network. The application of neural network in system identification and developing inverse model is discussed in this chapter. Chapter 3 describes the operation of thermistor along with its mathematical models. The development of direct and the inverse model of thermistor using neural network is discussed in this section. Chapter 4 describes the operation of thermocouple along with its polynomial models. The different types of thermocouple are described. The development of the direct and the inverse models of the thermocouple using neural network is discussed in this section. Chapter 5 deals with the linearization of thermistor using neural networks. Chapter 6 gives the conclusion of the entire work.

2

ARTIFICIAL NEURAL NETWORK TECHNIQUE

2 ARTIFICIAL NEURAL NETWORK TECHNIQUE

Artificial Neural Network (ANN) is a network of artificial neurons inspired by the biological neural network similar to the network of nerve cells in human brain. The neural network can be thought as a machine whose function is to perform a certain task in a way similar to that of brain. Usually, the electronic components are used for the implementation of neural networks. The digital computers are used for the simulation of neural networks in software. The presentation of the neural network is in the form of interconnected neurons in such a manner that they can calculate output values from the inputs. The neural network is designed in a manner which enables them to learn from the training data. The massively interconnected computing cells plays a very important role in making the neural network highly efficient. The ANN is similar to an Adaptive Machine which is defined as:

A neural network is a processor with massively distributed and parallel computing power which is capable of learning from its atmosphere. It consists of simple processing units called neurons that are capable of storing knowledge in the form of weights and biases [10]. It is similar to the brain in two aspects:

- a. A learning process plays a very important role for a neural network in acquiring knowledge from its environment*
- b. The synaptic weights which are the interneuron connection strengths stores the acquired knowledge during training*

Learning Algorithm is a set of task used to perform the learning of a neural network. In this process, the aim is to attain the desired design objective by modifying the synaptic weights of the network

2.1 Properties of ANN

Artificial Neural Network (ANN) has remained a topic of interest in the recent past. The artificial neural network is having wide range of application ranging from engineering to medicine and finance to physics. The important properties leading to the success of ANN are discussed below:

2.1.1 Power

ANN are having a very standardized approach which enables it in modeling very difficult functions. It is the nonlinear nature of ANN that makes it more powerful. The linear modeling has been the most accepted scheme because of its easy optimization. But the linear model gives significant errors, as in the case of thermistors which a highly nonlinear device. ANN proves to be a powerful tool in modeling nonlinear systems such as thermistor.

2.1.2 Ease of use

A very less user knowledge is involved in the use of neural network. The reason being the way in which the neural network learns. It needs an example for learning. A user only needs to gather and organize the training data and invoke a learning algorithm to begin the learning of the network. This is much simpler than using the traditional nonlinear models of the systems.

2.1.3 Nonlinearity

Due to highly distributed structure of the neural network and the presence of neurons which are nonlinear themselves, a neural network is always nonlinear. This nonlinearity is having a distributed nature in the network and plays a significant role if the systems which are producing inputs for the network are nonlinear.

2.1.4 Adaptivity

Neural networks are highly adaptive and they can change and adjust their weights in accordance with the changes in the environment they are kept. For example consider a neural network is trained to perform under certain environment. If certain features of the environment are changed suddenly, the network can easily adapt to these changes and retrain itself to work in those changed conditions

2.1.5 VLSI Implementation

The neural networks are highly parallel by their nature. Their very nature makes them fast for the calculation of outputs. Their nature of massive parallelism makes them suitable for VLSI technology.

2.2 Model of a neuron

A neuron is the basic and the most important unit of a neural network. The general block diagram of a typical neuron is given in Fig. 2.1. The basic units of neuron are discussed below:

1. The synaptics are described by a weight or strength of its own. A signal x_j at the input of synapse j is connected to neuron k after multiplying with w_{kj} . Both the positive as well as negative values lies in the range of the synaptic weight of an artificial neuron.
2. An adder (Summing Junction) is used for summing weighted inputs of each neuron.
3. An activation function functions as a limiter to keep the output of neuron in specific limit.

The neuron shown in Fig. 2.1 contains an externally applied offset (bias) given by b_k . When bias b_k is positive, it increases the overall input applied to activation function. It lowers the overall

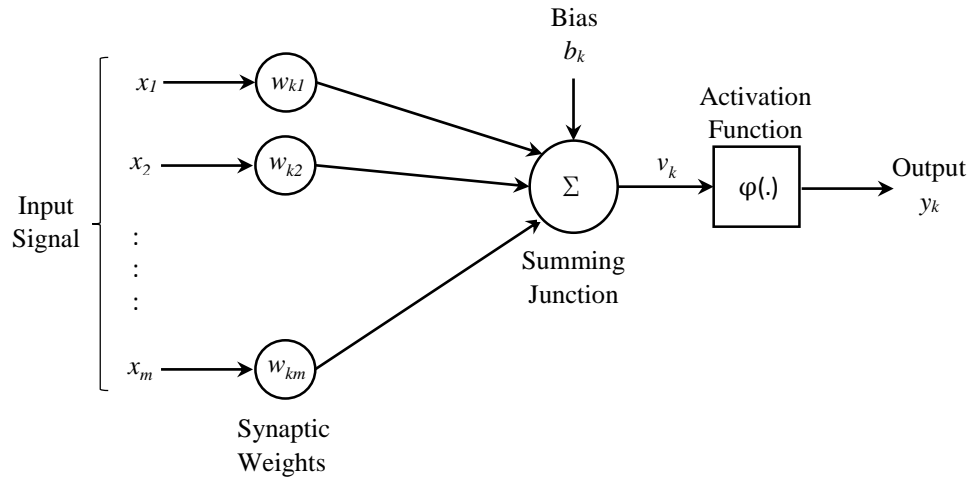

Fig. 2. 1 Model of Neuron

input to the activation function for a negative value.

Mathematically, the neuron k in Fig. 2.1 is described as,

$$u_k = \sum_{j=1}^m w_{kj}x_j \quad (2.1)$$

and

$$y_k = \varphi(u_k + b_k) \quad (2.2)$$

where x_1, x_2, \dots, x_m are the input signals; $w_{k1}, w_{k2}, \dots, w_{km}$ are the respective synaptic weights of the neuron k ; u_k is the linear combiner output due to input signals; b_k is the bias; $\varphi(\cdot)$ is the activation function and y_k is the output of the neuron. The use of bias b_k applies an affine transformation to the output u_k of the linear combiner in the model of Fig. 2.1 shown by

$$v_k = u_k + b_k \quad (2.3)$$

where v_k is termed as induced local field. So neuron output becomes

$$y_k = \varphi(v_k) \quad (2.4)$$

The activation function $\varphi(v)$ is the output of the neuron in terms of the induced local field v . The various activation functions along with their definitions are explained below

(a) Threshold Function

The Threshold Function is

$$\varphi(v) = \begin{cases} 1, & \text{if } v \geq 0 \\ 0, & \text{if } v < 0 \end{cases} \quad (2.5)$$

This Threshold Function is also called as Heaviside function.

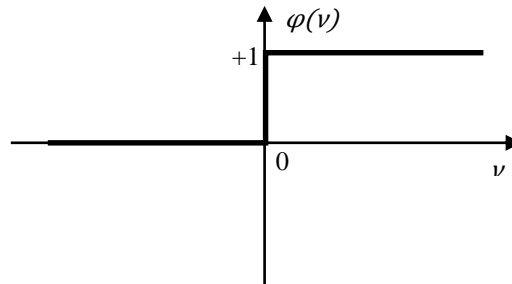

Fig. 2. 2 Threshold Activation Function

(b) Signum Function

The Signum Function is

$$\varphi(v) = \begin{cases} 1, & \text{if } v > 0 \\ 0, & \text{if } v = 0 \\ -1, & \text{if } v < 0 \end{cases} \quad (2.6)$$

The Signum Function is also called as Hardlimiter function.

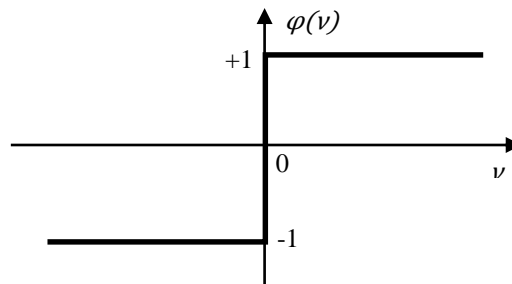

Fig. 2. 3 Signum Activation Function

(c) Sigmoid Function

The Sigmoid Function is a commonly used activation function in the neural networks. It is strictly an increasing function. It is defined below:

$$\varphi(v) = \frac{1}{1 + \exp(-av)} \quad (2.7)$$

where a is the slope parameter. It is used to vary the slope of the function.

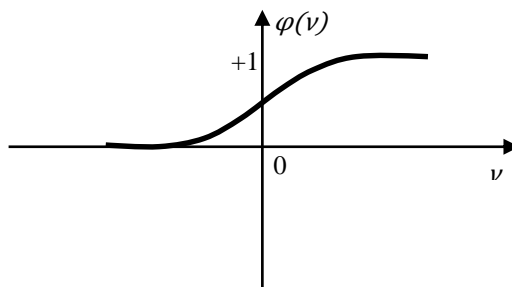

Fig. 2. 4 Sigmoid Activation Function

(d) Hyperbolic tangent function

The hyperbolic function limits the output between (-1, 1) and is defined as

$$\varphi(v) = \tanh(v) \quad (2.8)$$

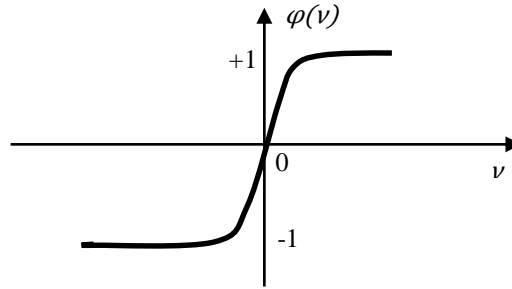

Fig. 2. 5 Hyperbolic Tangent Activation Function

2.3 Multilayer Perceptron (MLP)

The single layer neural network classifies linearly separable patterns only as it limits the computing power. So the neural network structure known as multilayer perceptron is introduced. The scheme of MLP is applied to a variety of difficult problems using a very popular supervised training algorithm known as Back-propagation Algorithm. The points which highlights the basic features of MLP are as shown below:

1. The activation function used in the neural model is nonlinear and differentiable.
2. One or more layers which are hidden from both the input and output nodes, i.e. hidden layer, are present in the network.
3. The MLP network is having a high degree of connectivity.

The Fig. 2.6 depicts the structure of a four layer multilayer perceptron having two hidden layers. $x_i(n)$ is the input of the first layer, f_j and f_k are the output of second and third layer and $y_l(n)$ is the output of the last layer of the MLP network. w_{ij} , w_{jk} and w_{kl} are the synaptic weights between Layer-1 and Layer-2, Layer-2 and Layer-3 and Layer-3 and Layer-4 respectively.

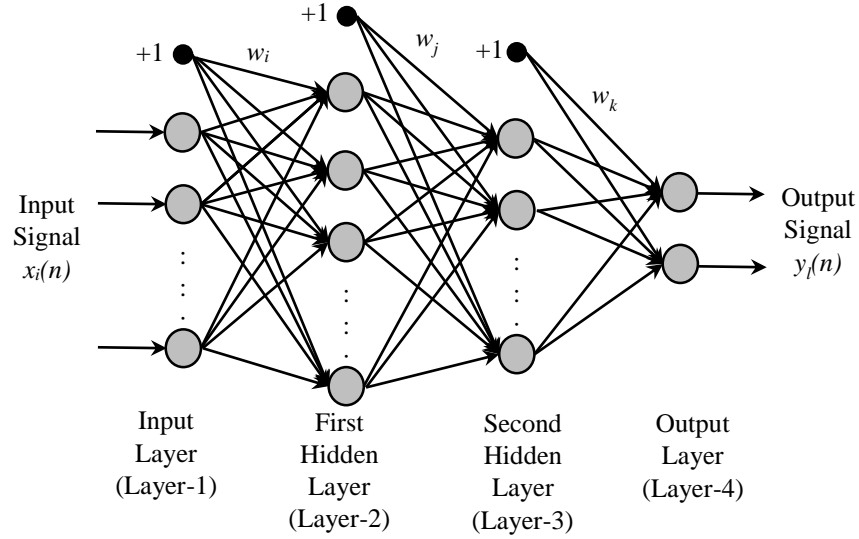

Fig. 2. 6 Structure of Multilayer Perceptron

If N_1 is total number of neurons in the Layer-2 then its output is

$$f_j = \varphi_j \left[\sum_{i=1}^L w_{ij} x_i(n) + \alpha_j \right] \quad (2.9)$$

$$i = 1, 2, \dots, L ; j = 1, 2, \dots, N_1$$

where α_j is the threshold of neurons of the Layer-2, L is total number of inputs and $\varphi(\cdot)$ is nonlinear and differential activation function in Layer-2 of network. If N_2 is the number of neurons in Layer-3 then its output is given by

$$f_k = \varphi_k \left[\sum_{j=1}^{N_1} w_{jk} f_j + \alpha_k \right] \quad k = 1, 2, \dots, N_2 \quad (2.10)$$

where α_k is the threshold of the neurons of Layer-3. If N_3 is total number of neurons in the Layer-4 then its output is

$$y_l(n) = \varphi_l \left[\sum_{k=1}^{N_2} w_{kl} f_k + \alpha_l \right] \quad l = 1, 2, \dots, N_3 \quad (2.11)$$

where α_l is the threshold of the neurons of Layer-4. The overall output of the network is expressed as

$$y_l(n) = \varphi_l \left[\sum_{k=1}^{N_2} w_{kl} \varphi_k \left[\sum_{j=1}^{N_1} w_{jk} \varphi_j \left[\sum_{i=1}^L w_{ij} x_i(n) + \alpha_j \right] + \alpha_k \right] + \alpha_l \right] \quad (2.12)$$

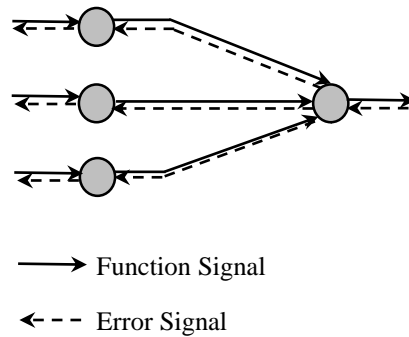

Fig. 2. 7 Two basic signal flows in a Multilayer Perceptron

Fig. 2.7 shows a portion of multilayer perceptron neural network. There are two types of signals in such a network:

(a) Function Signals-

A function signal can be viewed as an input signal (stimulus) that is present at the input end of the network, propagated through the network in the forward direction and comes out as an output signal at the output end of the network. It is of very significant use at the output of the network. A function signal passes through each neuron of the network and calculates signal which is function of the inputs and weights applied to the neuron. It functions similar to the input signal.

(b) Error Signals-

It is the signal generated at the output neuron and propagated backward in a layer by layer fashion in network.

2.4 Back-propagation Algorithm

Back-propagation algorithm is the training algorithm for multilayer perceptron. The multilayer perceptron training using back-propagation algorithm follows the phases given below:

1. This is the forward phase in which the synaptic weights of the network are kept fixed and the input signal propagates, layer by layer, in the network till it is reached at the output. Only the activation function and the output of neuron are affected in the network in this phase.
2. This is the backward phase in which an error signal is generated by comparison of the output of the network and the response that is desired. The error so produced is again passed through the network, layer by layer, but in the backward direction. The adjustments are applied to the synaptic weights of the network so as to reduce the error signal value.

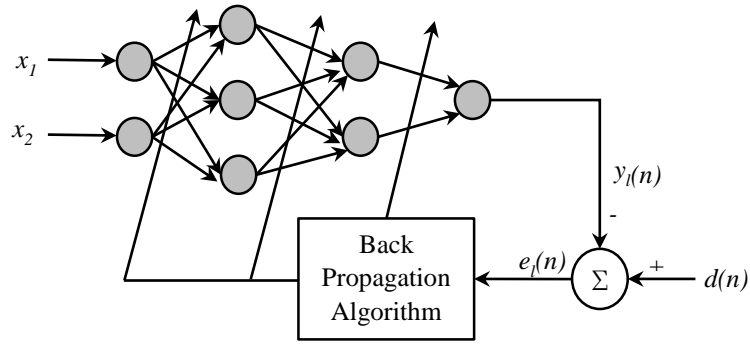

Fig. 2. 8 Neural Network employing Back-propagation Algorithm

A multilayer perceptron network with 2-3-2-1 architecture with back-propagation training algorithm is shown in the Fig. 2.8. Initially, a small and random value is used to initialize the weights and the biases. The comparison is made between the final output $y_l(n)$ and the desired response $d(n)$ and the error signal $e_l(n)$ is generated which is given by

$$e_l(n) = d(n) - y_l(n) \quad (2.13)$$

The total instantaneous error energy of the whole network is obtained by adding the error energy contributions of all the neurons of the output layer.

$$\xi(n) = \frac{1}{2} \sum_{l=1}^{N_3} e_l^2(n) \quad (2.14)$$

where N_3 is the number of neurons in the output layer.

The weights and thresholds of the hidden layers and the output layers are updated through error signal. The weights and the thresholds are adjusted iteratively until the error signal becomes minimum. The adjusted weights are given by

$$w_{kl}(n+1) = w_{kl}(n) + \Delta w_{kl}(n) \quad (2.15)$$

$$w_{jk}(n+1) = w_{jk}(n) + \Delta w_{jk}(n) \quad (2.16)$$

$$w_{ij}(n+1) = w_{ij}(n) + \Delta w_{ij}(n) \quad (2.17)$$

where $\Delta w_{kl}(n)$, $\Delta w_{jk}(n)$ and $\Delta w_{ij}(n)$ are the adjustments in the weights of the second hidden layer to output layer, first hidden layer to second hidden layer and input layer to first hidden layer respectively. Also

$$\begin{aligned} \Delta w_{kl}(n) &= -2\mu \frac{d\xi(n)}{dw_{kl}(n)} = 2\mu e(n) \frac{dy_l(n)}{dw_{kl}(n)} \\ &= 2\mu e(n) \varphi'_l \left[\sum_{k=1}^{N_2} w_{kl} f_k + \alpha_l \right] f_k \end{aligned} \quad (2.18)$$

where μ is the convergence coefficient ($0 \leq \mu \leq 1$). In similar manner, $\Delta w_{jk}(n)$ and $\Delta w_{ij}(n)$ can be calculated.

Similarly, the thresholds of each layer can be updated as under

$$\alpha_l(n+1) = \alpha_l(n) + \Delta \alpha_l(n) \quad (2.19)$$

$$\alpha_k(n+1) = \alpha_k(n) + \Delta \alpha_k(n) \quad (2.20)$$

$$\alpha_j(n+1) = \alpha_j(n) + \Delta \alpha_j(n) \quad (2.21)$$

where $\Delta \alpha_l(n)$, $\Delta \alpha_k(n)$ and $\Delta \alpha_j(n)$ are the adjustments in the thresholds of the output layer and the hidden layers. The adjustments in the thresholds are given by

$$\begin{aligned} \Delta \alpha_l(n) &= -2\mu \frac{d\xi(n)}{d\alpha_l(n)} = 2\mu e(n) \frac{dy_l(n)}{d\alpha_l(n)} \\ &= 2\mu e(n) \varphi'_l \left[\sum_{k=1}^{N_2} w_{kl} f_k + \alpha_l \right] \end{aligned} \quad (2.22)$$

2.5 Application of Neural Network

The neural networks are applied to a wide array of problems prominent being the learning tasks of Pattern Association and Pattern Recognition. Neural network can be also be applied to problems of other domains such as Function Approximation. Take a nonlinear function given by the equation

$$\mathbf{f} = \mathbf{g}(\mathbf{x}) \quad (2.23)$$

where the vector \mathbf{x} works as an input, \mathbf{f} as an output and the function $\mathbf{g}(\cdot)$ is an unknown vector valued function. Although $\mathbf{g}(\cdot)$ is unknown but a set of sample values $\{(\mathbf{x}_i, \mathbf{f}_i)\}_{i=1}^N$ are given where N is the total training samples. Now a neural network is to be designed which will approximate the unknown function $\mathbf{g}(\cdot)$. Supervised learning can be employed with \mathbf{x}_i as the input vector and \mathbf{f}_i being the desired response.

The unknown functions can be easily approximated by neural network. This ability of neural network can be used in two significant ways

2.5.1 System Identification

Suppose equation $\mathbf{f} = \mathbf{g}(\mathbf{x})$ is a function which describes a single input single output system. Then the sample points $\{(\mathbf{x}_i, \mathbf{d}_i)\}_{i=1}^N$ are used in training the neural network as the model of the system. Consider \mathbf{y}_i as the actual output of the neural network produced when input is \mathbf{x}_i . The difference between \mathbf{f}_i and the network output \mathbf{y}_i gives an error \mathbf{e}_i as shown in the Fig. 2.9. The error is used in modifying the weights of the network so as to reduce the difference between the output of the unknown system and the neural model. This is repeated for the entire set of sample points until the error is minimized to a least desired value.

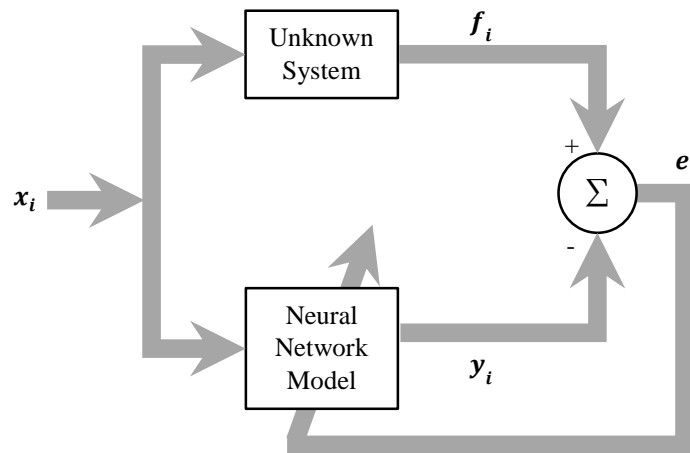

Fig. 2. 9 Block diagram of System Identification

2.5.2 Inverse Modeling

Suppose a known system described by equation $f = g(x)$. Now its inverse model is to be designed that gives the value of x when the input is f , the inverse system is given by

$$x = g^{-1}(f) \quad (2.24)$$

where the function $g^{-1}(\cdot)$ is the inverse of $g(\cdot)$.

In this case the f_i is the input and the x_i is the desired response. The error signal e_i gives the difference of x_i and the actual output y_i of the neural network as shown in Fig. 2.10. Similar to the system identification problem, the error is used in the modification of synaptic weights of the network which reduces the difference between the output of the neural model and actual system. The inverse modeling requires a more difficult learning than system identification because there may not be a unique solution for it.

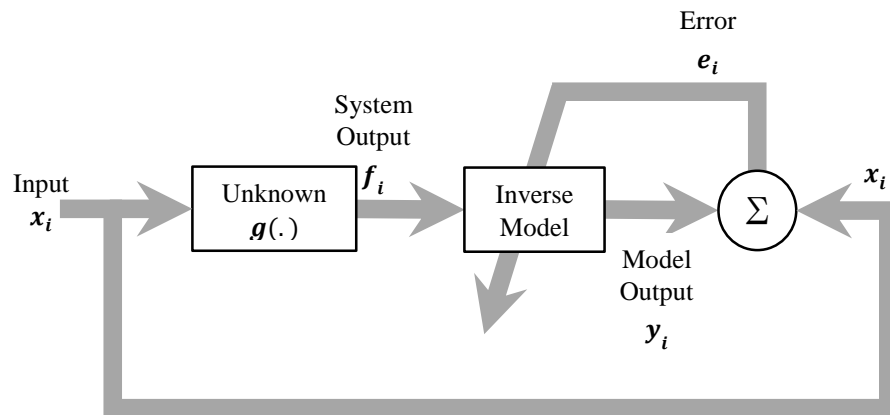

Fig. 2. 10 Block diagram of Inverse System Modeling

3

DIRECT AND INVERSE MODELING OF THERMISTOR

3 DIRECT MODELING AND INVERSE MODELING OF A THERMISTOR USING NEURAL NETWORK TECHNIQUE

This chapter deals with the design and development of direct model and inverse model of very important temperature sensor i.e. thermistor. The thermistor finds extensive use in the temperature measurements owing to its low cost and high degree of accuracy. But it exhibit nonlinear relationship between its input-output characteristics. This prevents its direct digital readout and provides restriction to its dynamic range. Also the accuracy of the thermistor is affected by ageing and variation in environmental parameters. The direct model is similar to a thermistor giving similar responses. The design of direct model using neural network is identical to the system identification problem of control system. The direct model of a sensor helps in determining the faults in sensor. The inverse model compensates for the nonlinearity present in the sensor. The inverse model is same as channel equalization issue associated with communication systems communication system.

3.1 Thermistor

Thermistor is simply a resistor whose resistance varies with the change in temperature. This is the reason why they are also called as temperature sensitive resistors. Thermistors are made up of semiconductor materials and hence, their resistivity is more sensitive to the temperature.

3.1.1 Basic Operation

Taking linear approximation into account, the resistance and temperature relationship is given by

$$\Delta R = k\Delta T \quad (3.1)$$

where ΔR is the resistance change, ΔT is the temperature change, k is the constant. The value of k determines whether the thermistor is either a positive temperature coefficient (PTC) thermistor or a negative temperature coefficient (NTC) thermistor.

3.1.2 Thermistor Classification

Thermistors are classified either as a PTC device or an NTC device depending on the value of k . When k is positive, the resistance increases with rise in temperature and the device is PTC type. When k is negative, the resistance decreases with rise in temperature and the device is NTC type.

For negative k the resistance decreases with the increase in temperature and the device is called as a negative temperature coefficient (NTC) thermistor. Resistors that are not meant to work as a thermistor are having the value of k close to zero so that the resistance does not change with the change in temperature.

a) NTC

The NTC thermistors are constructed from materials such as sintered metals and oxides that are used in semiconductors. The increase in the temperature causes increase in the active charge carriers which enables more current through the material, thus, decreasing its resistance. The ferric oxide (Fe_2O_3) with titanium (Ti) doping forms an n-type semiconductor material with electrons as active charge carriers. The nickel oxide (NiO) with lithium (Li) doping forms a p-type semiconductor material with holes as active charge carriers.

b) PTC

PTC thermistors functions similar to a switch. At a particular value of temperature, there is an abrupt rise in the resistance of PTC thermistors. They are constructed from doped polycrystalline substances like barium titanate (BaTiO_3) and similar compounds. With the variation in the temperature, the dielectric constant of such substances varies. There is a high dielectric constant at temperature below the Curie point temperature preventing the formation of potential barriers between the crystal grains. This is the reason for low resistance values under such conditions. At this point the material has a small negative temperature coefficient. At the Curie point temperature, there is a rise in the resistance value owing to the less value of dielectric constant.

3.1.3 Thermistor Mathematical Models

The Steinhart-Hart equation and β equation are the most commonly used thermistor mathematical models which are discussed below.

a) Steinhart-Hart Equation:

The linear approximation of temperature resistance relationship in a thermistor works well only within a small range of temperature. For error-free temperature measurements, a more accurate approximation in the form of an equation is desired. Steinhart-Hart equation is a used widely which is described below

$$\frac{1}{T} = a + b \ln(R) + c (\ln(R))^3 \quad (3.2)$$

where a , b and c are Steinhart-Hart parameters; T is the absolute temperature; R is the resistance. The Steinhart-hart equation gives error of 0.02°C . The constants a , b and c are calculated from experimental measurements of resistance. Consider datapoints of a typical thermistor in the Table 3.1.

Table 3. 1 Datapoints of a typical 10 k Ω thermistor

T ($^\circ\text{C}$)	R (Ω)
0	28063
25	10000
50	4136

Using these values, three equations in a , b and c are obtained.

$$\begin{aligned} \frac{1}{273} &= a + b \ln(28063) + c (\ln(28063))^3 \\ \frac{1}{298} &= a + b \ln(10000) + c (\ln(10000))^3 \\ \frac{1}{323} &= a + b \ln(4136) + c (\ln(4136))^3 \end{aligned} \quad (3.3)$$

From the above equations, the value of Steinhart-Hart parameters a , b and c is computed and given as under

$$a = 7.37 \times 10^{-4}$$

$$b = 2.78 \times 10^{-4}$$

$$c = 6.79 \times 10^{-8}$$

b) β equation:

The NTC thermistors are characterized by another type of equation known as B or β parameter equation. The β equation is similar to Steinhart-Hart equation with

$$a = \frac{1}{T_0} - \frac{1}{\beta} \ln(R_0); \quad b = \frac{1}{\beta}; \quad c = 0 \quad (3.4)$$

From (4.2) and (4.4) the following B or β parameter equation is obtained

$$\frac{1}{T} = \frac{1}{T_0} + \frac{1}{\beta} \ln\left(\frac{R}{R_0}\right) \quad (3.5)$$

where the T_0, T are in kelvin and R_0 is the resistance corresponding to temperature T_0 . Now solving for R , the following equation is obtained

$$R = R_0 e^{-\beta\left(\frac{1}{T_0} - \frac{1}{T}\right)} \quad (3.6)$$

The β parameter is very important as far as thermistor materials and thermistor components are concerned. All the commercially available thermistors are having their β parameter values specified in their datasheets. The information about the sensitivity of the thermistor material is interpreted from the β parameter value. Fig. 3.1 shows the Resistance Temperature curve of a typical NTC thermistor which clearly shows the nonlinear relationship between them.

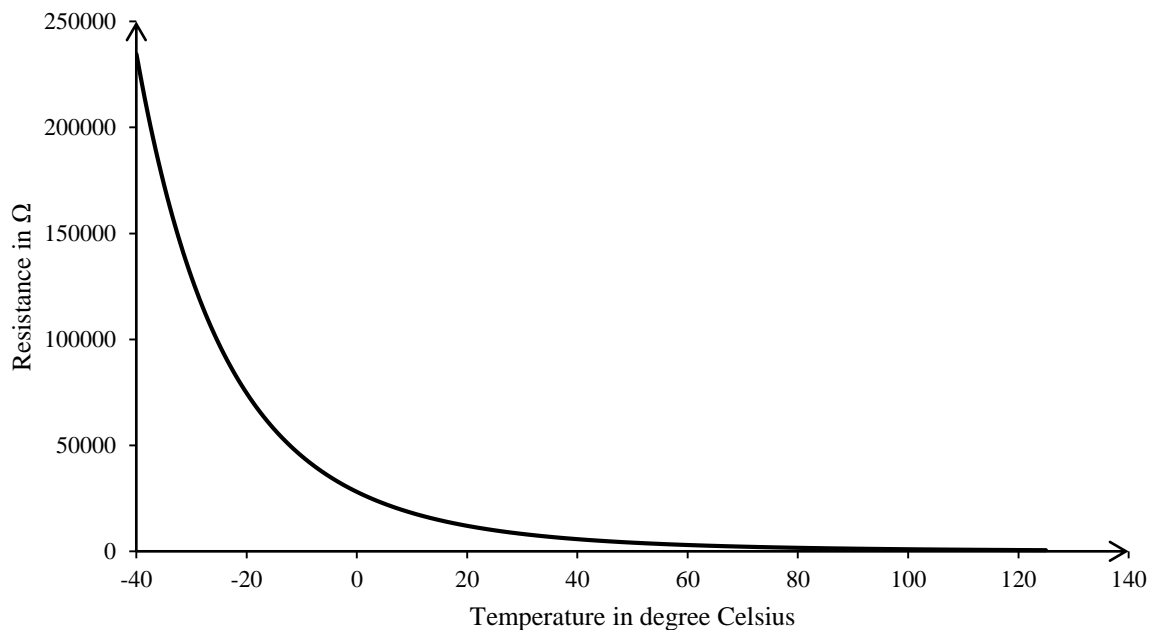

Fig. 3.1 Characteristic of a thermistor

3.1.4 Self-Heating Effect of thermistor

Heat is generated in a thermistor when current flows through it. This heat is the cause of the rise in temperature of the thermistor. This will naturally cause error in the measurement of temperature. So compensation mechanism are employed to compensate for the rise in temperature due to self-heating of thermistor. If the ambient temperature is already known, the thermistor can measure altogether different physical quantity other than temperature. For example it can measure the flow rate of a liquid as the heat dissipation of the thermistor is proportional to the flow rate of the fluid.

3.2 Voltage Divider Circuit

Fig. 3.2 shows a voltage divider circuit (VDC) which provides an equivalent voltage proportional to the resistance of thermistor. Also the resistance of the thermistor is related with its temperature. It means that the VDC simply acts as a resistance to voltage converter. The voltage V_T is given by

$$V_T = \frac{R_S}{R_S + R_T} \times 5 \quad (3.7)$$

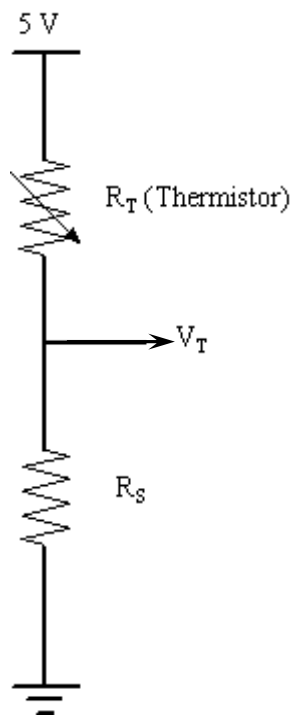

Fig. 3. 2 Voltage Divider Circuit for Resistance to Voltage Conversion of a thermistor

3.3 Development of Direct Model and Inverse Model of Thermistor

A scheme for the development of direct and inverse model of the thermistor has been proposed in this section. The direct modeling is proposed to calibrate inputs and estimate the intrinsic parameters of the thermistor whereas the inverse modelling is proposed for the estimation of the temperature sensed by the thermistor.

3.3.1 Direct Modeling

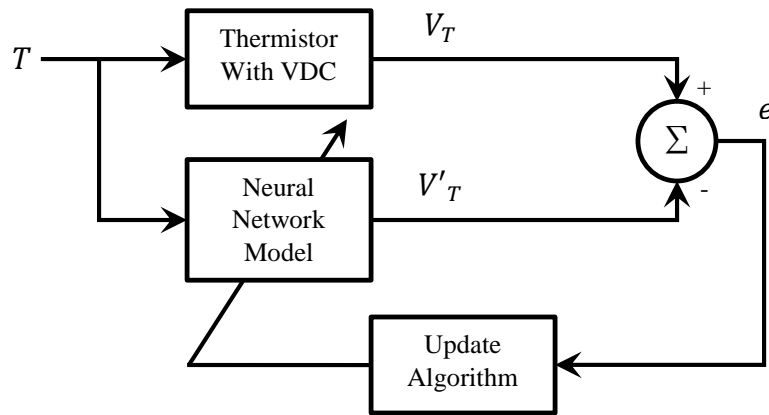

Fig. 3. 3 A scheme for direct modeling of Thermistor with VDC using neural network based model

The direct modeling is similar to the system identification problem of control system. The direct model behaves so, that its output and the output of the thermistor with VDC are almost same. The thermistor with VDC provides a voltage which is equivalent to the resistance of the thermistor which in turn reflects the temperature sensed by the thermistor. By changing the temperature of the thermistor, there is a change in the resistance of the thermistor. By using a voltage divider circuit with thermistor an equivalent voltage proportional to the change in the temperature is obtained. Fig. 3.3 shows a scheme for direct modeling of thermistor with VDC using neural network based model. Here only the temperature is affecting the output voltage of the thermistor (VDC) V_T . So the normalized temperature T is the input to the VDC circuit. The output voltage V_T of the VDC and the output voltage V'_T of the neural model are compared to produce value of e . This value of e is taken to update the neural network model. The neural network model is developed by the application of Multilayer perceptron and Back-propagation Algorithm.

3.3.2 Inverse Modeling

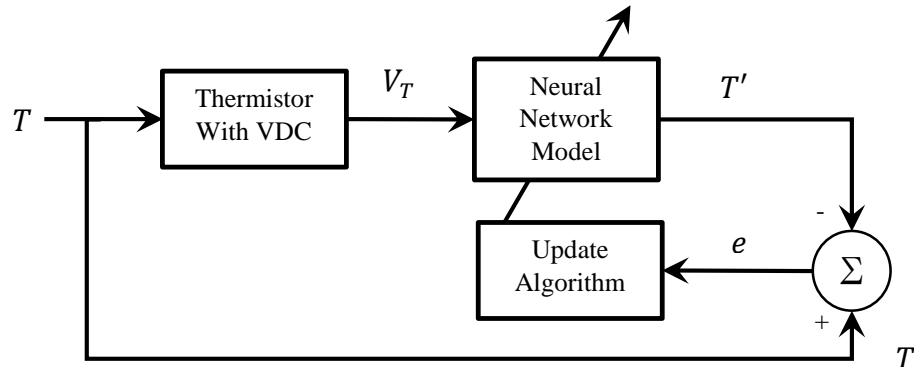

Fig. 3. 4 A scheme for inverse modeling of Thermistor with VDC using neural network based model

Fig. 3.4 shows a scheme for inverse modeling of thermistor with VDC involving neural network based model for the estimation of applied temperature. This is identical to the channel equalization problem in the communication receiver to cancel the adverse effects of the channel for the transmitted data. The direct digital reading of the applied temperature is obtained by cascading the inverse model of the thermistor with it so as to compensate for the nonlinearity of the thermistor. The training and the testing data are used in the same manner as it is used in the direct modeling scheme. The only difference is that the normalized voltage V_T works as input and the normalized temperature T works as output of the inverse model.

3.4 Simulation Results

The neural models, both direct and inverse have been simulated in MATLAB. The Neural Network Toolbox of MATLAB is used. The output voltage V_T of the voltage divider circuit implemented using thermistor is obtained from equation (3.7). The value of resistance for different temperature for a particular thermistor is obtained from equation (3.6) by using the following values of constants

$$\beta = 3380 \text{ per } K; R_0 = 10000\Omega; T_0 = 298K \quad (3.8)$$

The detailed explanation of the neural network based direct and inverse modeling is shown below.

3.4.1 Neural network based direct modeling of thermistor

Simulation of the Multilayer perceptron based neural network is carried so as to get the direct model of the thermistor. Simulation is done using a two layer multilayer perceptron with 1-5-1 structure similar to Fig. 2.6 is used which will behave as the direct model of thermistor. Here the first layer indicates the input layer with only one input. The second layer is the hidden layer consisting of 5 neurons. Finally, the third layer is the output node with only single output. The activation function used in hidden and the output layer is $\tanh(\cdot)$ as in Fig. 2.5. The Back-Propagation Algorithm adjusts the weights of the neural network. The normalized temperature T_N is the input to the neural network and the normalized output voltage V_{TN} is the target. The weights of the network are updated as per Back-propagation algorithm after application of input dataset. Each iteration comprises of application of all the input datasets. To let the network learn effectively, 1000 iterations are made. After completion of training, the weights are stored for future use. While testing the network the stored weights are loaded and the input in the form of normalized temperature T_N is fed to the trained neural network (Direct Model of Thermistor). The output from the model is compared with the actual output to study the accuracy of the direct model. The plot of actual characteristics and the estimated characteristics of the thermistor model is shown in Fig. 3.5.

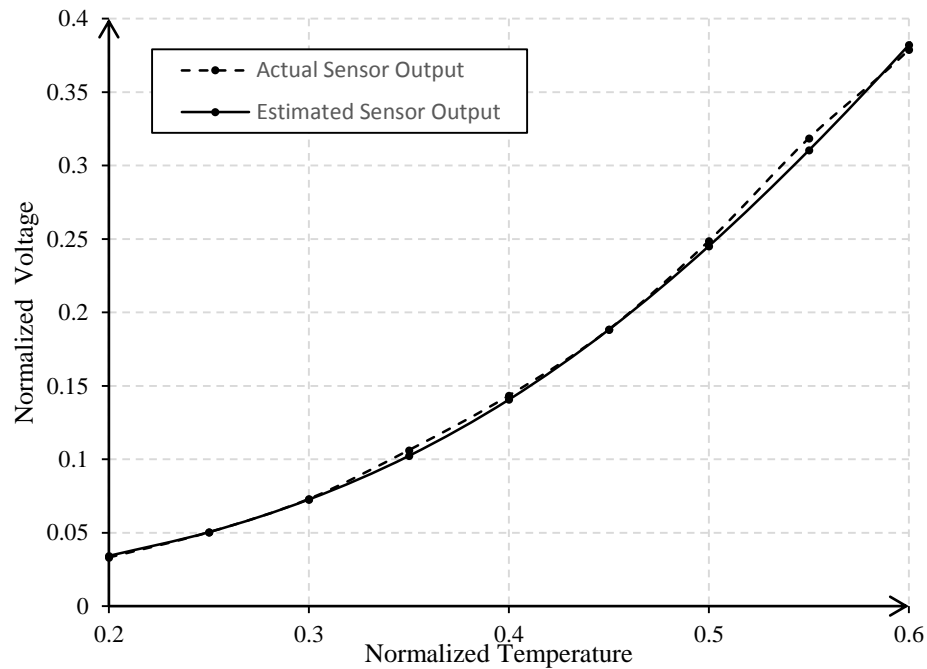

Fig. 3.5 Plot of Actual and Estimated Output of thermistor sensor

3.4.2 Neural network based inverse modeling of thermistor

Same structure 1-5-1 of the multilayer perceptron is used for the simulation of the inverse model of the thermistor. Similar training method is used to train the neural network. The network is trained for 1000 iterations by Back-propagation algorithm and the adjusted weights are stored in the memory. The only difference is the normalized voltage becomes the input and the normalized temperature becomes the output. In testing of the inverse model, the thermistor output V_{TN} is applied to the network and the estimated temperature T_N is obtained from the neural model. The plots in case of neural model are shown in Fig. 3.6.

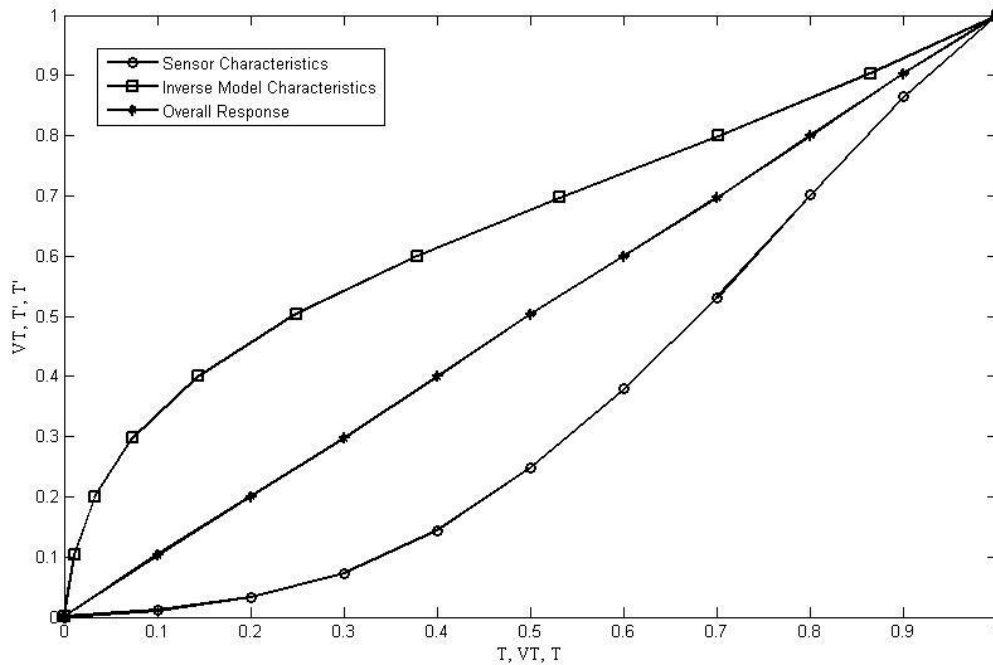

Fig. 3. 6 Plots of forward, inverse and overall characteristics of the thermistor

4

DIRECT AND INVERSE MODELING OF THERMOCOUPLE

4 DIRECT MODELLING AND INVERSE MODELLING OF A THERMOCOUPLE USING NEURAL NETWORK TECHNIQUE

This chapter deals with the design and development of direct model and inverse model of very temperature sensor thermocouple. The thermocouple finds extensive use in the temperature measurements owing to their low cost and simplicity. Although the accuracy of thermocouples is less than thermistors, still they are widely used due to their wide temperature sensing range. But they exhibit nonlinear relationship between their input-output characteristics if used over full sensing range. This prevents their direct digital readout and provides restriction to their dynamic range. Also the accuracy of these sensors is affected by ageing and variation in environmental parameters. The direct model is similar to a thermocouple giving similar responses. The design of direct model using neural network is same as the system identification problem of control system. The direct model of a sensor helps in determining the faults in sensor. The inverse model compensates for the nonlinearity present in the sensor. The inverse model is same as the channel equalization problem of communication system to cancel the adverse effects of channel.

4.1 Thermocouple

A thermocouple is a device to measure temperature and it consists of two different conductors that are connected to each other at one or more locations which are called junctions. Due to the temperature difference at the junctions of a thermocouple, a voltage is produced. Thermocouples are most used as a temperature sensor for measurement and control. Junction with dissimilar metal produces a voltage related to temperature gradient at its junction. Thermocouples that are used for measuring the temperature practically are made up of specific alloys which gives predictable relationship between temperature and voltage. Thermocouples made up of different alloys operates in varying temperature ranges.

4.1.1 Principle of operation

Under the effect of a thermal gradient every conductor generates voltage. This phenomenon is called the thermoelectric effect or the Seebeck effect. For voltage measurement, another conductor must be connected at the hot end. This additional conductor also experiences the thermal gradient

causing a voltage to be developed opposing the previous one. The amount of voltage developed is dependent on the type of metal.

4.1.2 Polynomial Model of thermocouple

Polynomial model is an approximated equation to show the relationship between the temperature sensed and the voltage produced by the thermocouple. It is given as under

$$T = d_0 + d_1E + d_2E^2 + \dots + d_nE^n \quad (4.1)$$

where T is sensed temperature; E is voltage generated; d_0, d_1 , etc. are the polynomial coefficients. This polynomial equation is effective only when the reference junction is fixed zero degree celsius. Each thermocouple has polynomial equation with different coefficients for different operating temperature range. For example, a K-type thermocouple has three different polynomial equation. The National Institute of Science and Technology (NIST) has provided the polynomial equations for different types of thermocouples along with temperature-emf table for each thermocouple [12].

4.1.3 Thermocouple Measurement

The block diagram for thermocouple measurement is shown in the Fig. 4.1. The desired temperature T_{SENSE} is acquired by using the three important quantities – the thermocouple characteristic function $E(T)$, the voltage measured V and the reference junction temperature T_{REF} . These three quantities are combined below

$$E(T_{SENSE}) = V + E(T_{REF}) \quad (4.2)$$

where $E(T)$ is the voltage produced when the hot junction of the thermocouple is at temperature T and the reference junction is kept constant at zero degree celsius.

To measure the desired temperature T_{SENSE} , the measurement of V is not sufficient. As in equation (4.2), the value of T_{REF} must be determined.

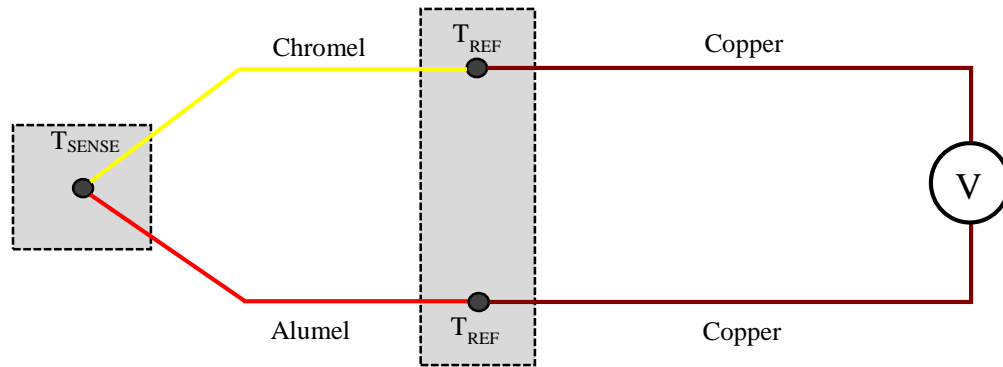

Fig. 4. 1 Thermocouple measurement scheme

The following two methods are used for solving this problem of T_{REF} .

- Ice Bath Method: In this method the reference junction is kept in a bath of water in such a way that the temperature remains at 0°C . Thus the reference junction is fixed at a constant temperature of 0°C .
- Reference Junction Thermometer: In this method, the temperature of the reference junction is not fixed and it varies with the ambient temperature. This varying temperature is measured by another thermometer (mostly thermistor or RTD).

In the above two cases equation (4.2) is used for calculating $E(T_{SENSE})$ and from the temperature-emf chart for a particular thermocouple the value of $E(T_{SENSE})$ is obtained.

4.1.4 Ageing of thermocouple

Thermocouples are mostly used at extreme temperature with reactive atmospheric conditions. Due to such atmospheric conditions the thermocouple is prone to ageing. These extreme conditions causes the thermoelectric coefficients of the thermocouple to vary with time resulting in drop in the voltage produced. The equation (4.1) alongwith the specific coefficients for a particular thermocouple, say K-type, is correct only if each wire of thermocouple is homogeneous. The wires of the thermocouple loose this homogeneity owing to the consistent and extreme exposure to high temperature resulting in permanent chemical and metallurgical changes.

4.1.5 Types of thermocouple

There are industry standards of thermocouple depending on the certain combination of alloys used. The selection of combination of alloys depends on the output, stability, chemical properties, melting point and cost. Also the selection of a particular type of thermocouple depends on particularly application. The factors important for selection are usually temperature range, sensitivity, magnetic properties and chemical inertness of the thermocouple material. The thermocouple types are explained in the following section with their characteristic functions shown in the Fig. 4.2.

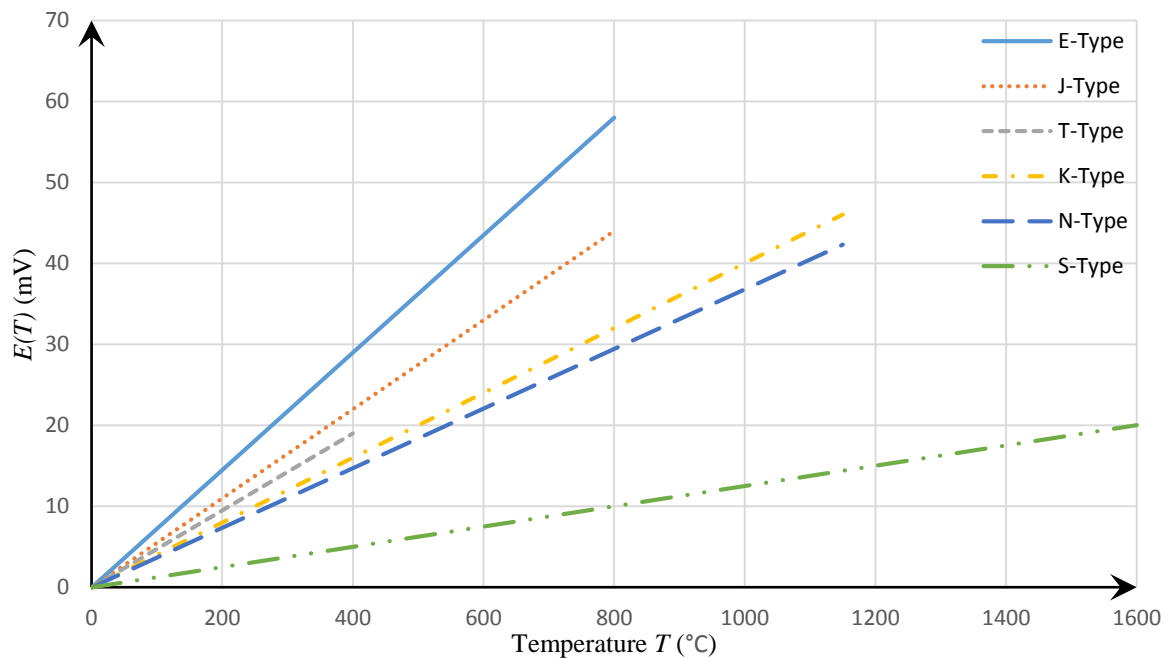

Fig. 4. 2 Characteristic functions of different thermocouple types

a) E-Type

The E-type (chromel-constantan) thermocouple is having a high output ($68\mu\text{V}/^\circ\text{C}$) which is suited for use in cryogenics applications. It is non-magnetic by nature and having range -110°C to 740°C . In E-type, the chromel forms the positive electrode and the constantan forms the negative electrode provided the junction temperature is above reference temperature. Same thing follows for the rest of the thermocouple types.

b) J-Type

The J-type (iron-constantan) thermocouple is having sensitivity $50\mu\text{V}/^\circ\text{C}$. It is having range -40°C to 750°C .

c) T-Type

The T-type (copper-constantan) thermocouple is having a having a sensitivity of about $68\mu\text{V}/^\circ\text{C}$. It is non-magnetic by nature and having range of operation from -200°C to 350°C .

d) K-Type

Type K (chromel-alumel) is having an operating range from -200°C to 1350°C . The sensitivity of K-type thermocouple is around $41\mu\text{V}/^\circ\text{C}$. Since nickel is its constituent metal which is magnetic, it undergoes a deviation in output when reaches Curie Temperature.

e) N-Type

N-type (nicrosil-nisil) thermocouple is suitable in the range of -270°C to 1300°C . The sensitivity of N-type thermocouple is around $39\mu\text{V}/^\circ\text{C}$.

f) S- Type

S-type (platinum 90% / rhodium 10% - platinum) thermocouple can operate up to 1600°C but its sensitivity is very less.

4.2 Development of Direct Model and Inverse Model of Thermocouple

A scheme for the development of direct and inverse model of the thermocouple has been proposed in this section. The direct modeling is proposed to calibrate inputs and estimate the intrinsic parameters of the thermistor whereas the inverse modelling is proposed for the estimation of the temperature sensed by the thermocouple.

4.2.1 Direct Modeling

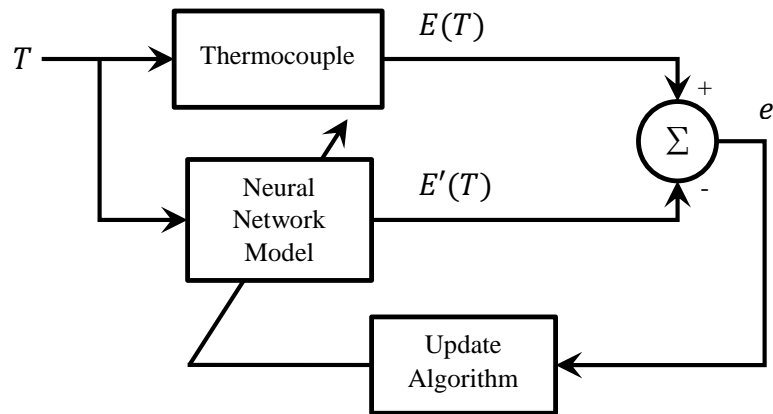

Fig. 4. 3 A scheme for direct modeling of Thermocouple using neural network based model

The direct modeling is same as the system identification problem of control system. The direct model behaves so, that its output and the output of the thermistor with VDC are almost same. The thermocouple provides a voltage which reflects the temperature sensed by the thermocouple. By changing the temperature of the thermocouple, there is a change in the output voltage of the thermocouple. Fig. 4.3 shows a scheme for direct modeling of thermocouple using neural network based model. Here only the temperature is affecting the output voltage of the thermocouple $E(T)$. So the normalized temperature T is used as the input to the thermocouple. The output voltage $E(T)$ of the thermocouple and the output voltage $E'(T)$ of the neural model are compared to produce error e . The neural network model is updated using this error information. The neural network model is developed by the application of Multilayer perceptron and Back-propagation Algorithm.

4.2.2 Inverse Modeling

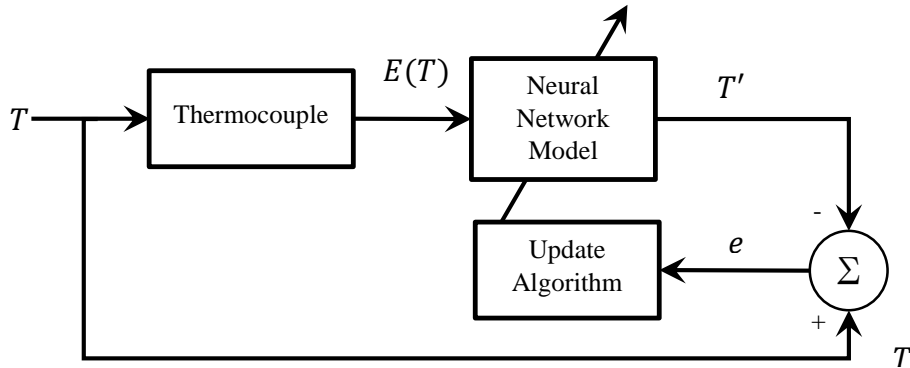

Fig. 4. 4 A scheme for inverse modeling of Thermocouple using neural network based model

Fig. 4.4 shows a scheme for inverse modeling of thermocouple using neural network based model for the estimation of applied temperature. This is similar to the channel equalization problem of digital communication system to cancel the adverse effects of the channel on the data which is transmitted. The direct digital reading of the temperature is obtained by cascading the inverse model of the thermocouple with it so that the nonlinear characteristics of thermocouple are compensated. The generation of the training set and the testing set of the data is similar to the direct modeling scheme. The only difference is that the normalized voltage $E(T)$ works as input and the normalized temperature T works as output of the inverse model.

4.3 Simulation Results

The neural models, both direct and inverse, for a K-type thermocouple have been simulated in MATLAB. The training data for the K-type thermocouple is obtained from NIST [12]. The detailed explanation of the neural network based direct and inverse modeling is shown below.

4.3.1 Neural network based direct modeling of thermocouple

Simulation of the Multilayer perceptron based neural network is carried to get the direct model of thermocouple. For simulation purpose, a two layer multilayer perceptron with 1-5-1 structure similar to Fig. 2.6 is used which will behave as the direct model of thermocouple. Here the first layer indicates the input layer with only one input. The second layer is the hidden layer consisting of 5 neurons. Finally, the third layer is the output node with only single output. The activation function used in both the layers is $\tanh(\cdot)$ as shown in Fig. 2.5. The Back-Propagation Algorithm

modifies the weights of the neural network. The normalized temperature T is the input to the neural network and the normalized output voltage $E(T)$ is the target. The weights of the network are updated as per Back-propagation algorithm after application of input dataset. Each iteration comprises of application of all the input datasets. To let the network learn effectively, 1000 iterations are made. After training, the weights are stored for future use. During testing the network uses the stored weights and the input in the form of normalized temperature T is fed to the trained neural network (Direct Model of Thermocouple). Comparison is made between the actual output and the output from the model. The plot of actual characteristics and the estimated characteristics of the thermocouple model is shown in Fig. 4.5.

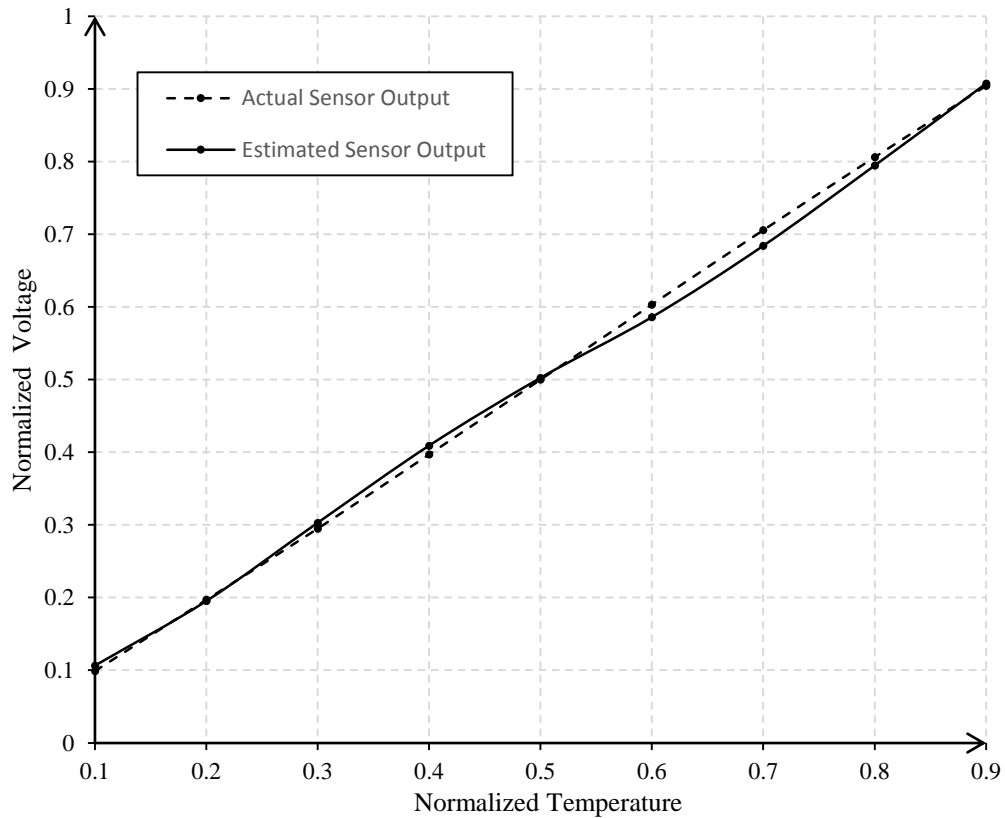

Fig. 4. 5 Plot of Actual and Estimated Output of thermocouple sensor

4.3.2 Neural network based inverse modeling of thermocouple

Same structure 1-5-1 of the multilayer perceptron is used for the simulation of the inverse model of the thermocouple. Similar training method is used to train the neural network. The network training is done for 1000 iterations using Back-propagation algorithm and the adjusted weights are stored in the memory. The only difference is the normalized voltage becomes the input and the normalized temperature becomes the output. In testing of the inverse model, the thermocouple output voltage $E(T)$ is applied to the network and the estimated temperature T is obtained from the neural model. The plots in case of neural model are shown in Fig. 4.6.

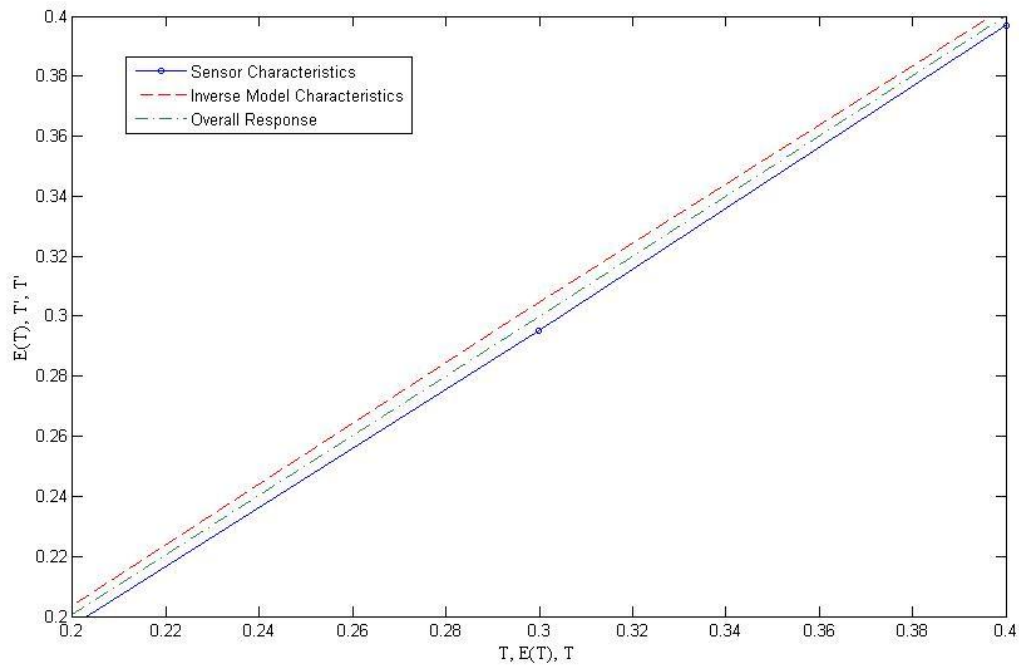

Fig. 4. 6 Plots of forward, inverse and overall characteristics of the thermocouple

5

NEURAL NETWORK BASED SENSOR LINEARIZATION

5 NEURAL NETWORK BASED SENSOR LINEARIZATION

Many sensors provide nonlinear input-output behavior. Analog circuits are used to improve the nonlinearity of sensors. But sometimes the complex circuits along with the component tolerances and temperature drift makes it impossible to use analog method of linearization. These days microcomputer based systems are used for nonlinearity compensation of sensors. For compensating the nonlinearity using arithmetic operations, an accurate model of the sensor is required. The Look-up table is also used in micro-controller based applications but a large amount of memory is required to attain high resolution. Neural network based sensor linearization can be achieved by using comparatively less amount of memory and processing power. In neural network based sensor linearization, a single input single output (SISO) multilayer perceptron network is used where input is the sensor measurement output data and the target is the corresponding desired linear data [11]. Fig. 5.1 shows the block diagrams of the implementation of neural network based linearization. Fig. 5.1(a) illustrates that the neural network is trained with nonlinear sensor characteristics data as input and the desired linear characteristics data as target. Fig. 5.1(b) shows the sensor output V_{nl} is input to the neural network that produces corresponding linear output V_l .

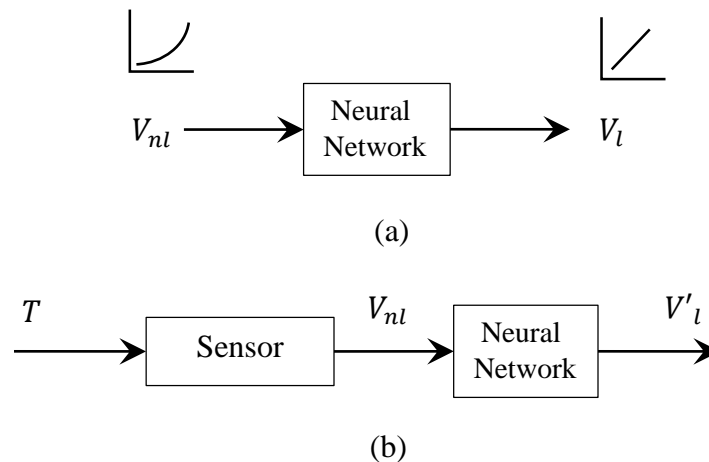

Fig. 5. 1 Neural Network based Linearization (a) Training and (b) Testing

5.1 Simulation Results

The voltage divider circuit of Fig. 3.2 is used to obtain the nonlinear voltage V_{nl} which reflects the temperature sensed by the thermistor. For the purpose of simulation study, a two layer multilayer perceptron with 1-5-1 structure similar to Fig. 2.6 is used. The normalized nonlinear output voltage V_{nl} is applied as an input to the network and the normalized desired linear voltage V_l is used as the target neural network training. All the other parameters and operations to train the neural network are similar to those discussed in section 3.4.1. After training, the weights are stored for future use. During the testing of network the stored weights are used in the network and the normalized nonlinear output voltage V_{nl} is fed to the trained neural network. Comparison is made between the output from the neural network V_l and the actual output to study the effectiveness of the network. The plots of actual nonlinear characteristics of the sensor and the estimated linear characteristics of the neural network are shown in Fig. 5.2.

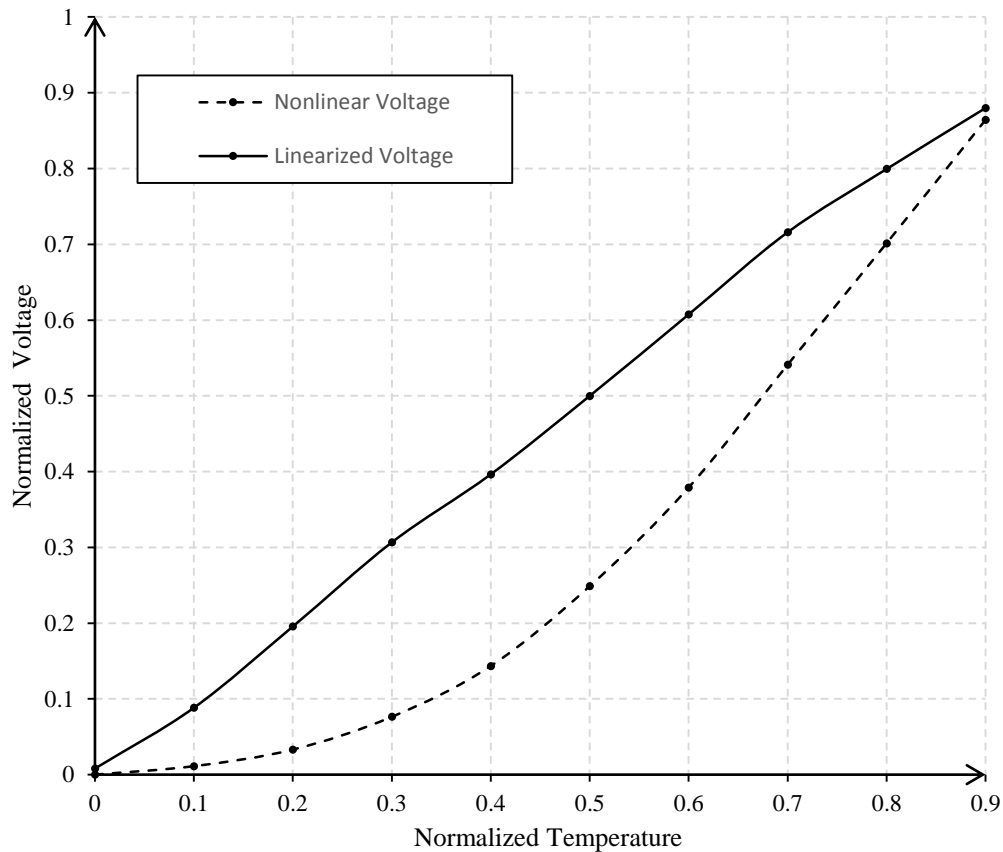

Fig. 5. 2 Characteristics of the sensor before and after linearization using neural network

6

CONCLUSION

6 CONCLUSION

The direct and the inverse model of thermistor as well as thermocouple are designed using neural network technique. The direct model of the thermistor shows the performance similar to the actual sensor. The direct model can be used in the detection of faults in the sensor. The nonlinearity issue of the thermistor can be compensated by using the inverse model of the thermistor. The overall response of the thermistor sensor circuit in series with the inverse model of the thermistor is linear which shows the nonlinearity compensation. Similar models are developed for thermocouple. Thermocouple is nonlinear when its operating range is extended. So inverse model is developed which removes such nonlinearity. Another method to get rid of nonlinearity of thermistor is by using the desired linear output voltage as the target of the neural network and the nonlinear output voltage as an input to the neural network. In this method, the output voltage obtained is in linear relationship with the temperature.

The models designed using the neural network are having very simple architecture. Such models can be implemented in simple microcontrollers reducing the cost of the system. The development of the model is done using the supervised learning. In applications where the training data is not available, unsupervised learning can be carried out. The sensors used in this work are thermistors and thermocouples. This technique can be applied to other sensors with more than one input to affect the output of the sensor.

BIBLIOGRAPHY

- [1] D. Patranabis, S. Ghosh, C. Bakshi, "Linearizing transducer characteristics," *IEEE Trans. Instrum. Meas.*, vol.37, no.1, pp. 66-69, 1988.
- [2] N. Medrano-Marqués, R. del-Hoyo-Alonso, B. Martín-del-Brío, "A Thermocouple Model Based on Neural Networks", *6th International Work-Conference on Artificial and Natural Neural Networks (IWANN) Spain*, pp. 531-538, 2001.
- [3] Medrano-Marques, N.J., Martin-del-Brio, B., "Sensor linearization with neural networks," *IEEE Trans. Ind. Elect.*, vol.48, no.6, pp. 1288-1290, 2001.
- [4] M. Attari, F. Boudema, M. Heniche; "An Artificial Neural Network to linearize a G (Tungsten vs. Tungsten 26% Rhenium) Thermocouple characteristic in the range of zero to 2000°C," *IEEE International Symposium on Circuits and Systems*
- [5] K. Danisman, I. Dalkiran, F.V. Celebi, "Design of a high precision temperature measurement system based on artificial neural networks for different thermocouple types," *Measurement*, vol.39, no.8, pp 695-700, 2006.
- [6] Dempsey, G.L., Alt, N.L., Olson, B.A., Alig, J.S., "Control sensor linearization using microcontroller-based neural network," *Proc. of IEEE Conference on Systems, Man and Cybernetics*, vol.4, pp. 3078-3083, 1997.
- [7] L. R. Klopfenstein, "Software linearization technique for thermocouples, thermistors and RTDs," *ISA Trans.*, vol.33, no.3, pp. 293-305, 1994.
- [8] Obaidat, M.S., Abu-Saymeh, D.S., "Methodologies for characterizing ultrasonic transducers using neural networks and pattern recognition techniques," *IEEE Trans. Ind.. Elect.*, vol.39, no.6, pp. 529-536, 1992.
- [9] J.C. Patra, G. Panda and R. Baliarsingh, "Artificial neural network based nonlinearity estimation of pressure sensors," *IEEE Trans. Instrumentation & Measurement*, vol.43, pp.874-881, Dec.1994.

- [10] Haykin, S., *Neural Networks and Learning Machines*, 3rd edition New Delhi, Prentice Hall, 2011.
- [11] Bhuyan, M., *Intelligent Instrumentation*, Florida, CRC Press, 2011.
- [12] National Institute of Science and Technology (NIST) ITS-90 Thermocouple Database.
Available: http://www.srdata.nist.gov/its90/download/type_k.tab