

HTS INDUCTIVE ENERGY CONTROLLED DISCHARGING CIRCUIT & ITS APPLICATION IN THE DESIGN OF UPS

*A Thesis submitted
To the department of Mechanical Engineering of
National Institute of Technology Rourkela*

*In partial fulfillment of the requirements for the degree of
Master of Technology in “Cryogenic and Vacuum Technology”*

By
Raj Shrivastava
(Roll 212ME5410)



Department of Mechanical Engineering National Institute of Technology,
Rourkela, Odisha, 769008, India

HTS INDUCTIVE ENERGY CONTROLLED DISCHARGING CIRCUIT & ITS APPLICATION IN THE DESIGN OF UPS

A Thesis submitted

*To the department of Mechanical Engineering of
National Institute of Technology Rourkela*

*In partial fulfillment of the requirements for the degree of
Master of Technology in “Cryogenic and Vacuum Technology”*

By

Raj Shrivastava

(Roll 212ME5410)

Under the supervision of

Prof. A.K. Panda



Department of Mechanical Engineering National Institute of Technology,
Rourkela, Odisha, 769008, India

ACKNOWLEDGEMENT

It is indeed a great pleasure for me to express my profound gratitude towards my guide, **Prof. A K Panda**, Head of Department, Department of Electrical Engineering, NIT Rourkela. His constant enthusiasm in guiding my work was indeed a source of inspiration to me. I am full of gratitude towards him for his intellectual and moral support in all phases of my project so that it could be brought to this stage of completion.

I have taken note of his critical review of the final version of this thesis, and accommodated his valuable suggestions for improvement.

I would like to take this opportunity to express my deep appreciation to the Department of Mechanical Engineering, NIT, Rourkela, for giving me the opportunity to work on this project.

I am also indebted to my family members for giving me necessary support and encouragement for completing this thesis. I am also beholden to all my friends for helping me in completing this project.

ABSTRACT

High temperature superconducting magnet (HTS) inductive energy charging and discharging characteristics and its nature has been theoretically dealt in this report and its detailed analysis by specific models and graphs has been presented so as to portray light on the future advancement in this field with the design of UPS. All the design are done using SIMULINK/MATLAB and the charging and discharging characteristics shows the advantage of HTS and, this simulation results will support the development of UPS (uninterruptible power source) using the SMES technology with substantial great advantages.

Superconducting Magnetic Energy Storage is a novel technology that stores electricity from the grid within the magnetic field of a coil comprised of superconducting wires with near zero loss of energy.

SMES is a grid enabling device that stores and release large quantities of power almost instantaneously. The organization is capable of releasing high levels of ability within a fraction of a cycle to replace sudden loss or dip in line power. Strategic injection of brief bursts of power can play a crucial part in maintaining grid reliability, especially with today increasingly congested power lines and the high penetration of renewable energy sources such as wind and solar.

A typical SMES consists of two parts- cryogenically cooled superconducting coil and power conditioning system which are motionless and result in higher reliability than many other power storage devices. Ideally, once the superconductivity coil is charged, the current will not decay and the magnetic energy can be stored indefinitely.

DECLARATION

This end semester Thesis project has been written by me.

Signature of the Student

Certified that the student has performed the project work under my supervision.

Signature of the Supervisor



DEPARTMENT OF ELECTRICAL ENGINEERING

CERTIFICATE

This is to certify that the Thesis titled “**HTS INDUCTIVE ENERGY CONTROLLED DISCHARGING CIRCUIT & ITS APPLICATION IN THE DESIGN OF UPS**”, submitted to the National Institute of Technology, Rourkela by **Raj shrivastava, Roll No. 212ME5410** for the award of Master of Technology in Mechanical Engineering, is a bonafide record of research work carried out by him under my supervision and guidance.

The candidate has fulfilled all the prescribed requirements.

This report, which is based on candidate’s own work, has not been submitted elsewhere for a degree/diploma.

In my opinion, the report is of the standard required in partial fulfillment of the requirements for the degree of Master of Technology in Cryogenics and Vacuum Technology.

Prof. A.K.Panda

Supervisor

Department of Electrical Engineering

National Institute of Technology

Rourkela – 769 008 (ODISHA)

CONTENTS

Acknowledgement	i
Abstract	ii
Declaration	iii
Certificate	iv
List of Symbols	viii
List of Figures	ix
1. Introduction.....	1-2
2. Literature review.....	2-3
3. Thesis objectives.....	3-4
4. Proposed work done.....	4-5
4.1 HTS Inductor being charged and energy stored across it	4
4.2 Mathematical explanation of the above Simulink model	5
5. MATLAB/ Simulink model designed for energy discharging and storing analysis.....	6-11
5.1 Simulation results	7
5.2 Graphs for HTS wire used in the design	9
5.3 Energy discharging analysis.....	10
6. Model designed in MATLAB/simulink for discharging circuit	11-14
6.1 Graphs of the discharging model.....	12
7. Preference of SMES over copper coil.....	15
7.1 Reason for choosing HTS in place of cheap copper wire?.....	15
7.2 Design of UPS.....	15

8. Three-phase rectifier design: model designed in MATLAB.....	16-17
8.1 Graph plotted: voltage vs time.....	17
9. Design of buck and boost converter for the base of UPS design.....	18-23
9.1 Design of RLC filter for buck and boost converter.....	18
9.2 Inductor design using mathematical calculation.....	19
9.3 Calculation for the value of capacitor.....	22
10. Design of buck converter with required LC filter design using Simulink.....	24-26
11. Design of PWM-converter circuit model design in MATLAB/Simulink.....	27-29
12. Design of open loop circuit of UPS (with DC output, inverter output and load output).....	30-33
12.1. Explanation of the circuit that has been designed in the MATLAB/Simulink.....	32
12.2. Observation.....	32
12.3. Calculation of the chopped inverter voltage.....	33
13. Conclusion.....	33
14. References.....	34

LIST OF SYMBOLS

U_p	Discharging Voltage
$U_R(t)$	Feedback Voltage Source, V
I_0	Initial current, A
$I(t)$	Instantaneous Current, A
$Q(t)$	Consumed Energy, J
R	Internal Resistance, Ω
η	Effective Efficiency
E	Inductive Energy J
Z	Load resistance, Ω
L	Initial inductance, H
t_s	Constant Power Discharging Time, sec
$E(t)$	Consumed Energy at any time 't'

LIST OF FIGURES

Figure 1. A simulation model of HTS inductor getting charged and energy getting stored across it	4
Figure 2. Matlab/ simulink of charging circuit	6
Figure 3. Discharging graph using copper wire in the matlab/simulink	7
Figure 4. Graph of residual energy vs time for Cu wire.....	8
Figure 5. Graph of consumed energy vs time for Cu-wire.....	8
Figure 6. Graph of consumed energy with time	9
Figure 7. Graph of residual current with time.....	9
Figure 8. Load current vs time	12
Figure 9. Total efficiency vs time	13
Figure 10. Efficiency vs time	13
Figure 11. Current vs time	14
Figure 12. Design of total circuit in precise.....	15
Figure 13. 3-phase rectifier design	16
Figure 14.3-phase voltage vs time with rms of 933.5 volts.....	17
Figure 15. Buck converter used in the a)switch on mode, b) switch off mode	18
Figure 16. Voltage across the buck converter has been measured using a voltage measurement device.....	24
Figure 17. Design of pwm circuit with 50 Hz frequency and sweeping frequency is taken as 0.5 hertz	27
Figure 18. Graph of different phase matlab/simulink (a)0° degree phase, (b)-120° degree phase and (c) 120° degree phase shift as the output of pwm converter	29
Figure 19. Design of open-loop ups circuit with dc-output, inverter output and load output.....	30
Figure 20. Graph of v_{dc} (volt) vs time (sec).....	30
Figure 21. Graph of v_{ab_inv} (volt) vs time (sec).....	31
Figure 22. Graph of v_{ab_load} (volts) vs time(sec)	31

1. INTRODUCTION

Superconducting magnet Energy storage (SMES) devices can store a large amount of energy as electromagnetic energy in HTS (High temperature superconducting) Inductors and discharge its very small amount of energy even after large interval of time if no load condition exists, reason being that it has very small resistance in series with it i.e. around an order of 10^{-3} ohms. So, its time constant tends to become very large thus it's time to decay down is very large and thus we can utilize the stored energy in different applications. SMES-HTS inductor has been compared with Cu wire inductor and the vast difference will be shown in this simulation work.

The main advantage of the SMES devices compared to other devices are: (a) High energy storage density, (b) High energy Storage efficiency, (c) Long Application life time and (d) less environmental pollution.

In this project, I have analyzed the HTS inductive energy of control charging and discharging characteristic and simulated using MATLAB which aims to study the practicality of SMES-UPS by introducing HTS Technology. Based on the simulation results and calculation done till today will help me in designing 3-phase uninterruptible power system (UPS) simulation using SIMULINK/MATLAB, with effective energy calculation, efficiency calculation and effective discharging time calculation.

2. LITERATURE REVIEW

A limited study has been taken regarding the use of super conducting magnet in the design of UPS and so, several previous work has been undertaken here to give the glimpse of the work. The work carried out by different scholars and different investigators has been presented here:

Jin, Xang et al. [1]: A method has been approached in this paper regarding the control of magnet energy storage and release scheme. This scheme has been approached in this paper so as to make the inductor more manageable and stable in reference to the amount of energy being stored across the inductor. As the energy consumption due to Cu coil inductor is very high so superconducting magnet is being used so that the energy storage can be maintained for a longer period and the inductor Energy can be maintained for a constant period. As this control scheme maintains the energy exchange and release process. The practical approach regarding this has been proposed in this paper “A Power Inductor Energy Control Scheme”

Buck, D. D. S [2]: This paper helps in the design of LC Filter for the buck converter that has been used and also for maintaining the voltage at a constant voltage but step down voltage. The synchronous buck converter is generally used to step down the dc voltage from a higher to lower level. To maintain the high performance the efficiency of the Power converter is very critical. So, to maintain a good efficiency this paper deals with a design of an appropriate LC filter. The Design has been taken in the “LC Selection guide for the DC-DC Synchronous Buck converter”

Xiaoyuan Chen, jianxun Jin. Et al. [3]: This Journal deals with the replacement of Copper conductor with SMES-HTS inductor and its verification being done o MATLAB/SIMULINK. High Temperature superconducting inductive analysis has been done theoretically and it’s detailed calculation and MATLAB/SIMULINK has been presented. And subsequently the approach for the design of UPS has been dealt here and with prior advantage over its contemporary copper inductor wire. And, at the end of this paper following inference can be brought out in picture that the zero

resistance of HTS-SMES inductor favours high current density with longer energy storing-time which is helpful in the design of UPS. As the energy stored in the HTS inductor should be controlled to match with a certain discharging power and thus high efficiency and effective storage energy is obtained. The Explanation has been done in “HTS energy Controlled Discharging Characteristics and UPS Application”

Xiao-Yuan Chen et al. [4]: High temperature superconducting inductor and its control scheme have been studied and analyzed in this journal. Using the MATLAB/Simulink a controlled release scheme has been proposed that has been used in the prototype design of UPS application. Steady state Control scheme have been proposed and have been verified by the UPS application in Simulink.” High Temperature Superconducting Magnetic Energy storage and its Power Control Application”

3. THESIS OBJECTIVES

The Objectives to be achieved in this study:

1. Modelling of different SMES circuits by comparing the parameters of a Cu wire and HTS inductor and then, presenting the reliability of HTS inductors in the field of electrical design in the forthcoming years.
2. The above fact has been based on the modelling of the RL circuit in the SIMULINK/MATLAB and its graph which is supported by a visual proof that the designing has been successful. And, the graph regarding the discharging energy, discharging current and effective efficiency will clearly support the fact.
3. In this thesis work, the aim is to build UPS (Uninterruptible power source) so as to store energy for longer periods. And, to design a 3-phase circuit with inverter and control circuit to make it really efficient for the near future.

4. PROPOSED WORK DONE

4.1. HTS INDUCTOR BEING CHARGED AND ENERGY STORED ACROSS IT

This circuit is a design of charging LC circuit taking first time resistance of copper and then taking the SMES-HTS resistance of value .001 ohm. And, in this simulation the scope displays the outputs of 4 parameters residual current, residual energy, consumed energy and difference between the consumed energy and energy of rated value respectively.

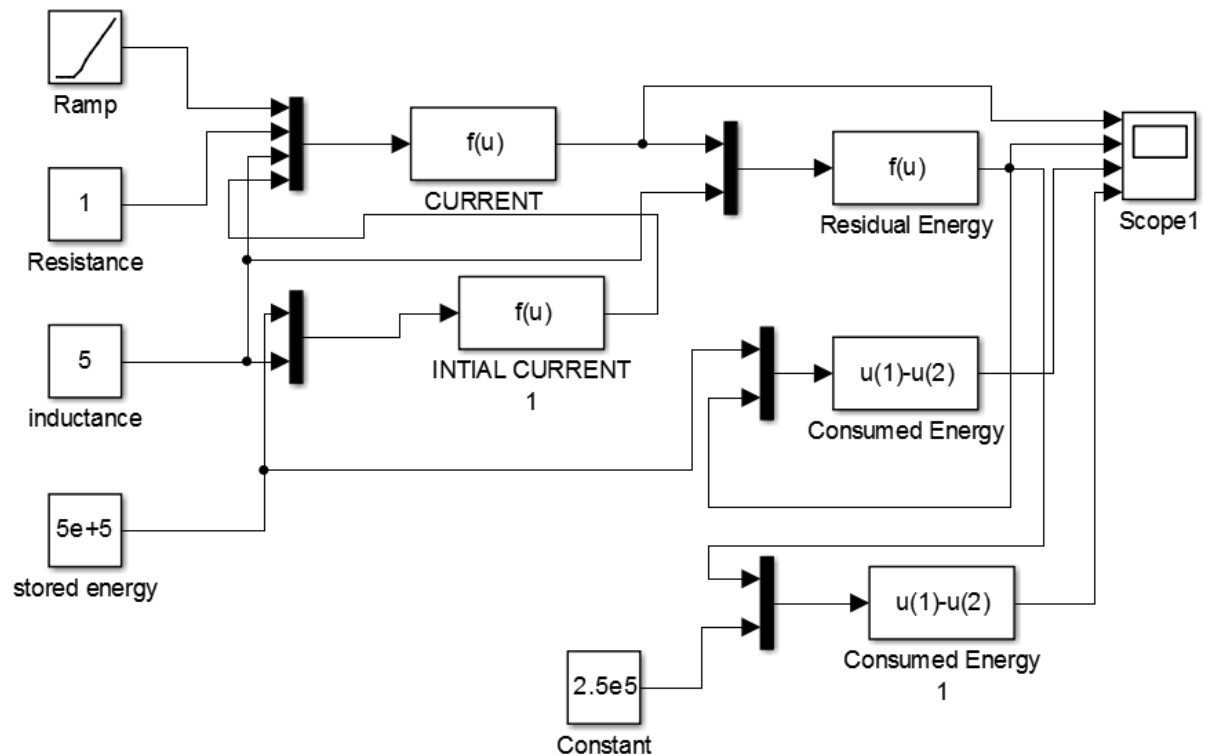

FIGURE 1: A SIMULATION MODEL OF HTS INDUCTOR GETTING CHARGED AND ENERGY GETTING STORED ACROSS IT

4.2. MATHEMATICAL EXPLANATION OF THE ABOVE SIMULINK MODEL

1. The energy stored in an inductor is expressed by following equation:

$$E = \frac{1}{2} LI^2$$

Where, L is the inductance of the inductor, I is the charging current

2. We have initially assumed a ZSR state (zero state response) i.e. Initial current across inductor is zero.

3. As, stored energy is given (i.e. the amount of energy that is to be stored in the magnetic field of inductor) which is taken as 500 KJ. So, initial current block equation is given as,

$$I_0 = \sqrt{\frac{2E(t)}{L}}$$

4. In, the charging process current is given by following equation,

$$i(t) = I_0 \left(1 - \exp\left(-\frac{R_e t}{L}\right) \right)$$

5. Residual energy at any time is defined as the difference in the initially stored energy and at any time till input source is applied

$$E = \frac{1}{2} Li(t)_0^2$$

6. Consumed energy is defined as the difference between the stored energy and Residual energy, which is the last block in the SIMULINK/MATLAB model.

7. The last block compares the consumed energy with threshold energy and Threshold energy and plot the difference

5. SIMULINK/MATLAB MODEL DESIGNED FOR ENERGY DISCHARGING AND STORING ANALYSIS

The simulation of Fig.2 done in MATLAB/Simulink is a design of charging circuit whose graph clearly indicates that the Residual current for the device with copper coil is more in comparison to that of SMES-HTS superconductor coil that has been used. The parameters that are associated with this simulation are Residual current and Residual Energy respectively.

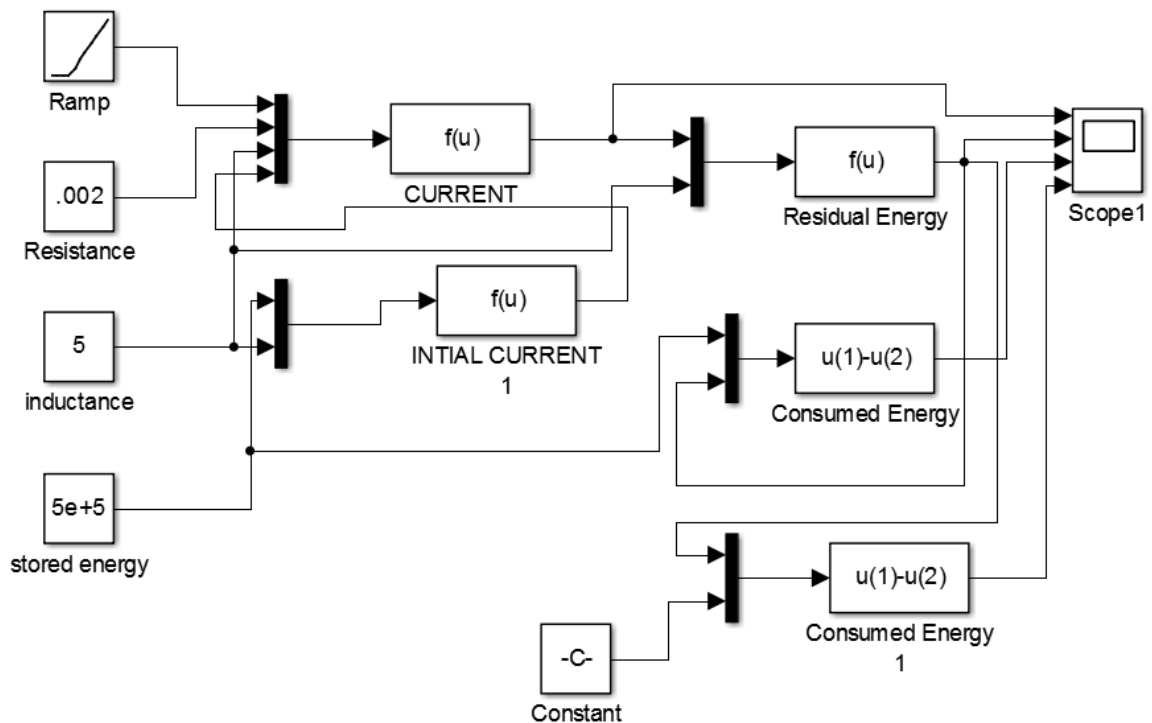

FIGURE 2: MATLAB/ SIMULINK OF CHARGING CIRCUIT

5.1. SIMULATION RESULTS

A.FOR Cu WIRE

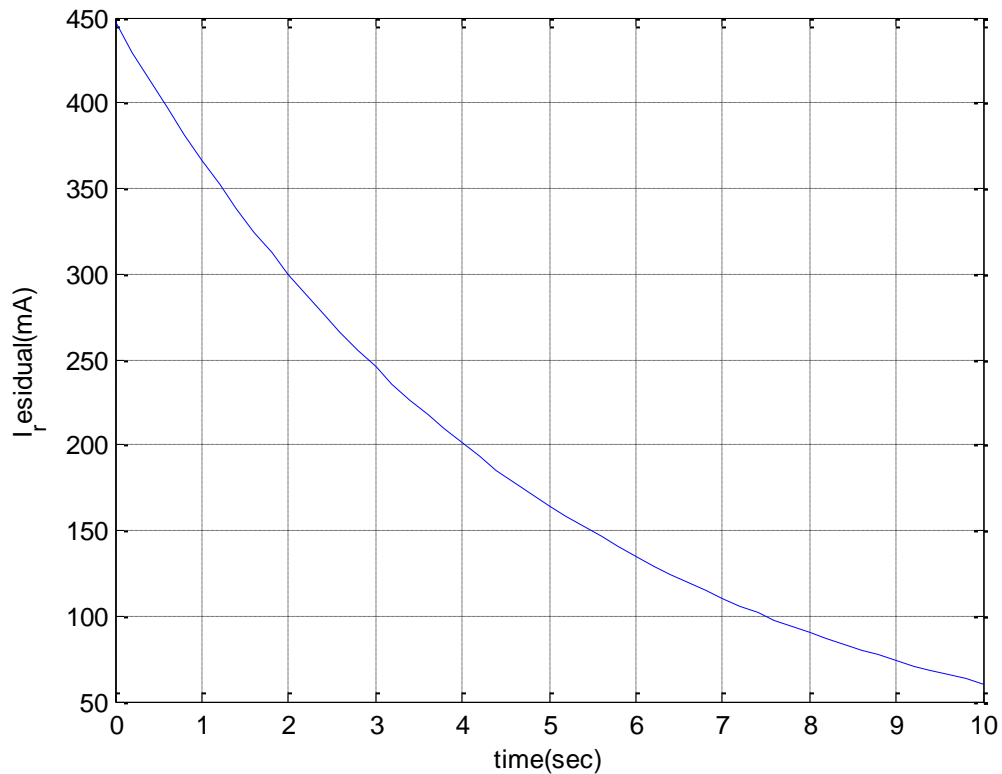

FIGURE 3: DISCHARGING GRAPH USING COPPER WIRE IN THE MATLAB/SIMULINK

GRAPH INFERENCES

The Fig. 4 &5 shows the graph of residual current and consumed energy for the device that has copper wire being used as an inductor. In period span of 10 seconds it is clearly indicated that if copper wire of 1 ohm resistance is used than the residual current almost goes to zero and energy consumed is also high as resistor acts as a dissipater and so even if the circuit is disconnected from the supply then also it can't store energy for a long period of time. While to its contemporary the SMES inductor does its work very efficiently.

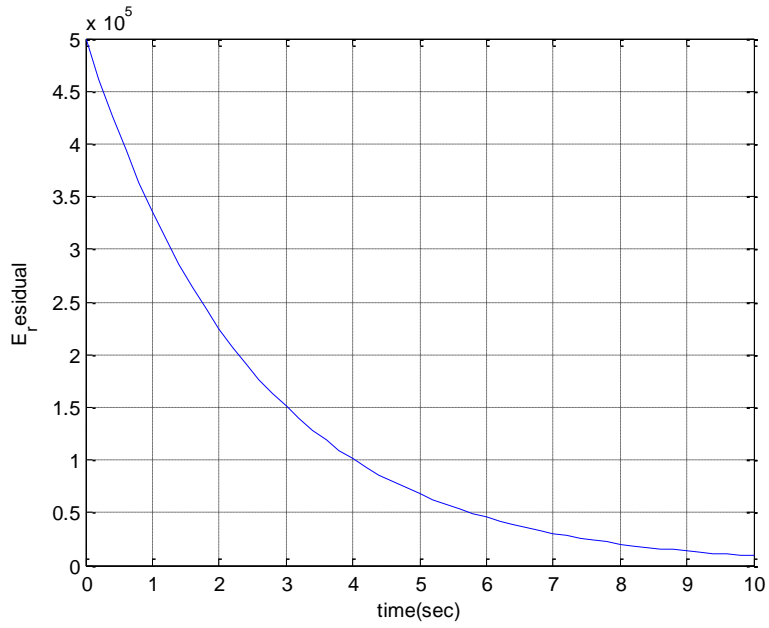

FIGURE 4: GRAPH OF RESIDUAL ENERGY VS TIME FOR CU WIRE

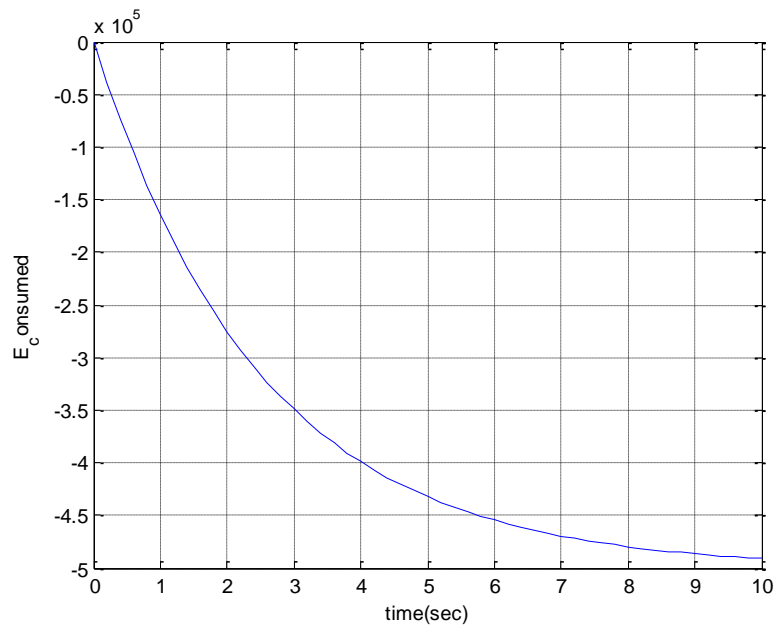

FIGURE 5: GRAPH OF CONSUMED ENERGY VS TIME FOR CU-WIRE

5.2. GRAPHS FOR HTS WIRE USED IN THE DESIGN

Now, the graph in Fig 6 &7 clearly explains the difference between the copper and superconducting coil as clearly can be seen the residual energy is almost the same as that of initial only a drop of .2 %, thereby supporting the design of UPS with the help of superconducting magnet coil.

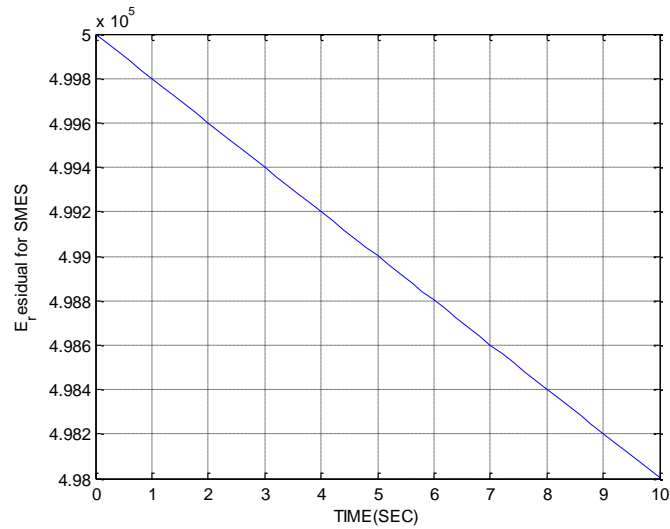

FIGURE 6: GRAPH OF CONSUMED ENERGY WITH TIME

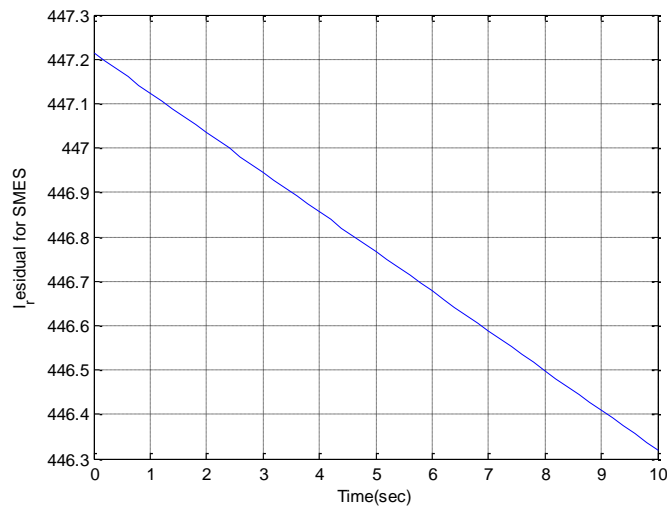

FIGURE 7: GRAPH OF RESIDUAL CURRENT WITH TIME

5.3. ENERGY DISCHARGING ANALYSIS

1. Assuming the initial state of current across inductor after input supply has been removed is I_0 , now stored current will decay with time and its equation regarding this will be,

$$E_2(t_2) = \frac{1}{2}L \left(I_0 \left(\exp\left(-\frac{R_e t_2}{L}\right) \right) \right)^2 \quad i(t) = I_0 \left(\exp\left(-\frac{R_e t}{L}\right) \right)$$

2. Now, the consumed energy by the inductor is given by;

$Q(t)$ = initial stored energy - energy stored at time t ;

So,

$$E(t) = \frac{1}{2}L \left(I_0 \left(1 - \exp\left(-\frac{R_e t}{L}\right) \right) \right)^2$$

3. Now, the inductor can be discharged with a constant power $P_0 (=U_p * I_p)$, thus the Residual energy at any time t is defined as,

$$E(t) = E - P_0(t) - Q_3(t)$$

4. Consumed energy in terms of the HTS inductor with the resistance R_e ,

$$Q(t) = \int i(t)^2 R_e dt$$

5. Similarly, residual current through the inductor is expressed as,

$$i(t) = \sqrt{\frac{2[E - P_0(t) - Q_3(t)]}{L}}$$

6. Load current is given by,

$$i(t) = I_p = \frac{P_0}{U_p}$$

7. The equation relating effective power and total usage power,

$$\eta = \frac{P_{0t_s}}{E} \times 100 \qquad \eta_t = \frac{P_{0t_s} + Q^{(t)}}{E} \times 100$$

6. MODEL DESIGNED IN MATLAB/SIMULINK FOR DISCHARGING CIRCUIT

This is a design of discharging circuit designed in MATLAB/Simulink which is culminated for only SMES-HTS coil that will clearly indicated in its result & the acme importance which makes it the most efficient and most valuable component in the design of UPS. Load current, residual energy, effective energy, consumed energy, efficiency and load current output is dealt in the upcoming results.

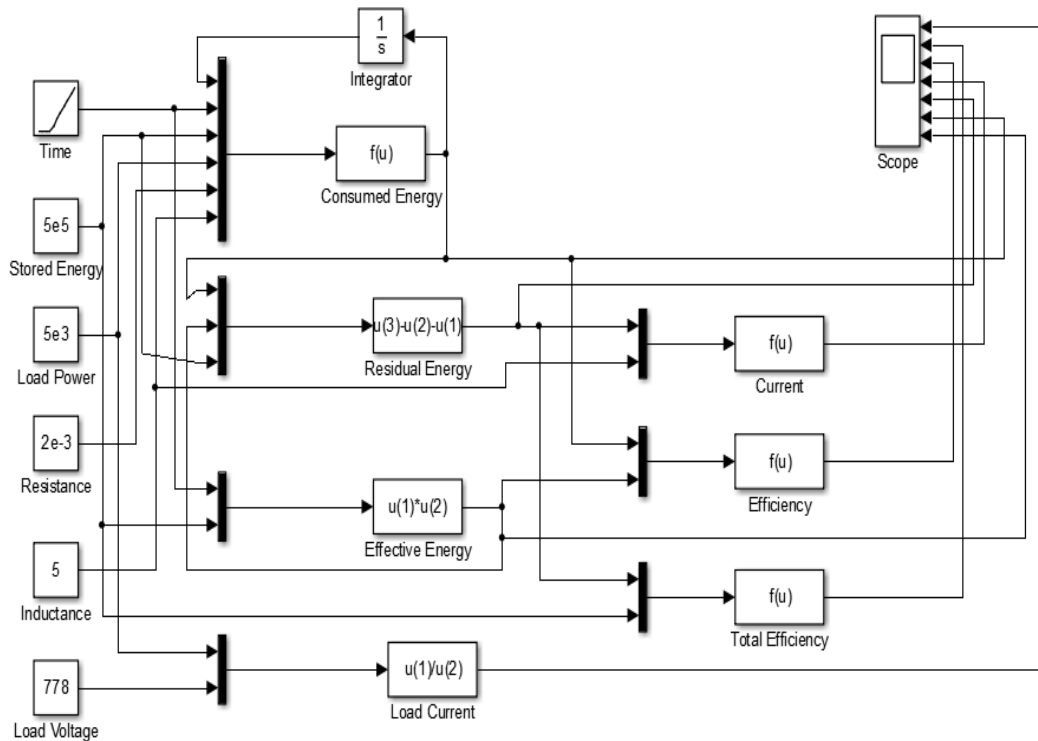

FIGURE 8: MODEL FOR DISCHARGING CIRCUIT MODELLED IN MATLAB/SIMULINK

6.1. GRAPHS OF THE DISCHARGING MODEL

The graphs in the Fig. 8,9,10 and 11 are the output for SMES simulation only. The Fig. 8 clearly shows that load current is almost constant at a particular value of 6.4 mA. And, due to this the total efficiency is also high which comes around 86% as compared to copper coil its very high.

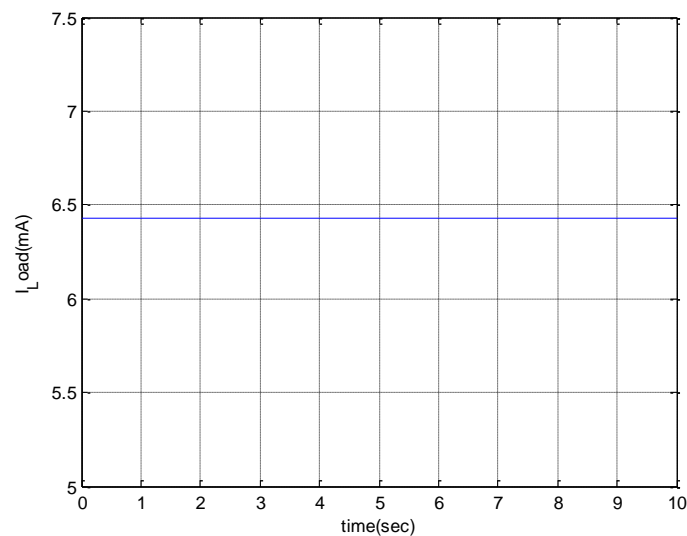

FIGURE 9: LOAD CURRENT VS TIME

And, in the course of the design the effective energy and consumed energy is very low which is a heading advantage over the general etiquettes that has been followed by copper coil. In the design, the discharging time is taken as 10 second and during which the efficiency is quite high and the consumed current is only high so as to maintain a high current density and thus high efficiency.

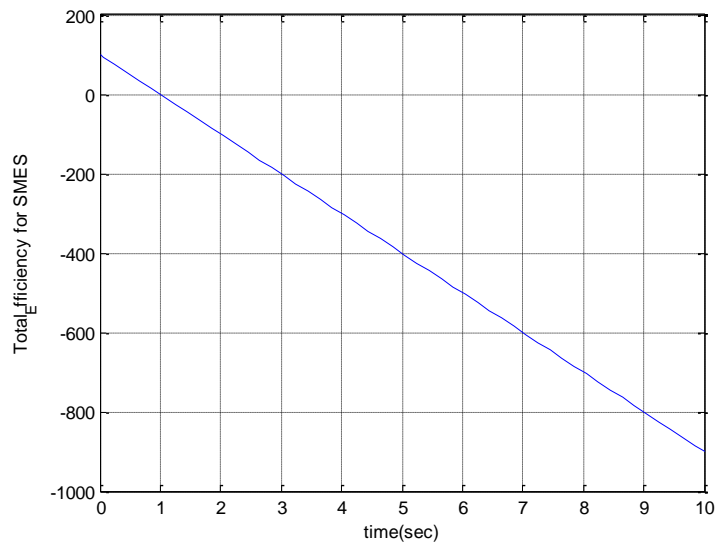

FIGURE 10: TOTAL EFFICIENCY VS TIME

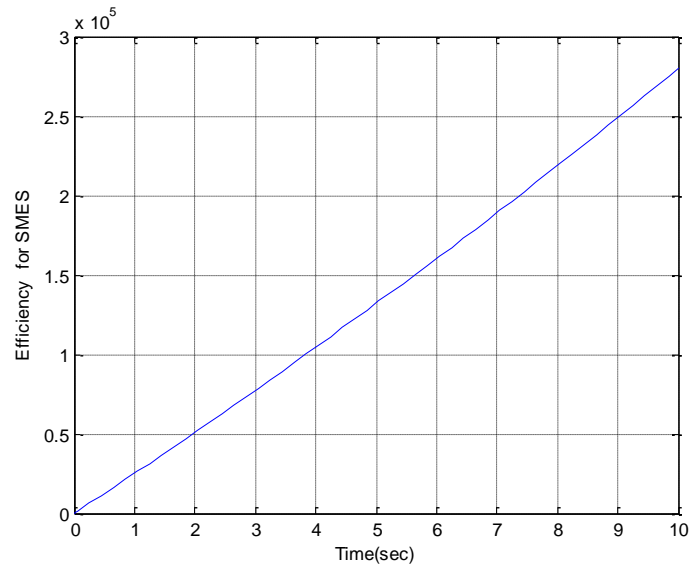

FIGURE 11: EFFICIENCY VS TIME

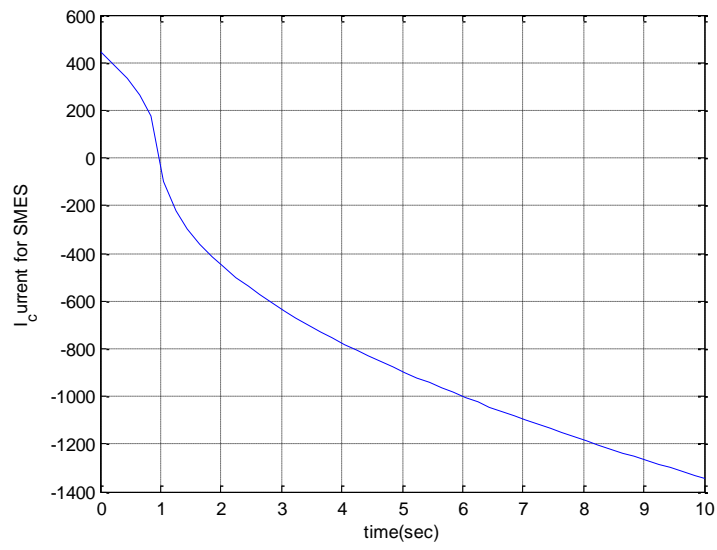

FIGURE 12: CURRENT VS TIME

7. PREFERENCE OF SMES OVER COPPER COIL

7.1 REASON FOR CHOOSING HTS IN PLACE OF CHEAP COPPER WIRE?

1. Thus, from above graph we can see that as discharge time increases as less is the discharge energy or in other words load which consumes less power i.e., P_0 (load power).
2. Thus, HTS inductor with larger stored energy value or the load with smaller power is favorable for obtaining longer discharging time and UPS application.
3. The total energy usage efficiency becomes higher while E increases or P_0 decreases.
4. A general ups stores energy for not more than a day but now this time can be increased, so this is the advantage of HTS.

7.2. DESIGN OF UPS

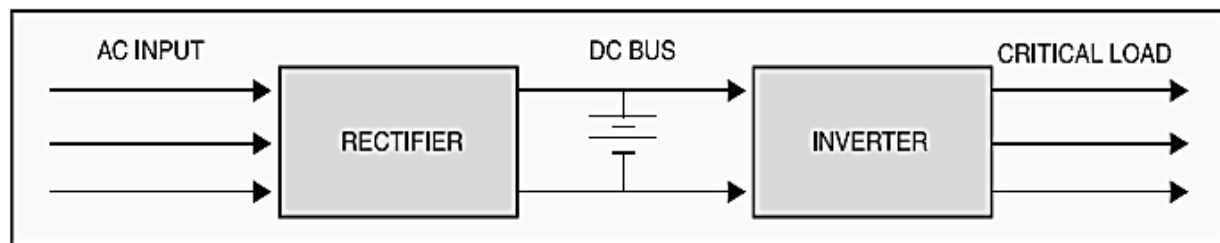

FIGURE 13 DESIGN OF TOTAL CIRCUIT IN PRECISE

1. Generally, we need to design the 3 phase rectifier and then 3 phase inverter and design of RLC FILTER at the load terminal for the inverter.
2. Rectifier converts AC to DC and it has got its own filter circuit to prevent the ripple.
3. And, from there we have to convert that dc to ac where actual critical load is present.

8. THREE-PHASE RECTIFIER DESIGN: MODEL DESIGNED IN MATLAB

The Design of 3 phase controlled bridge rectifier has been done in MATLAB/SIMULINK with a point of view that source that its output should Dc component with minimum ripple.

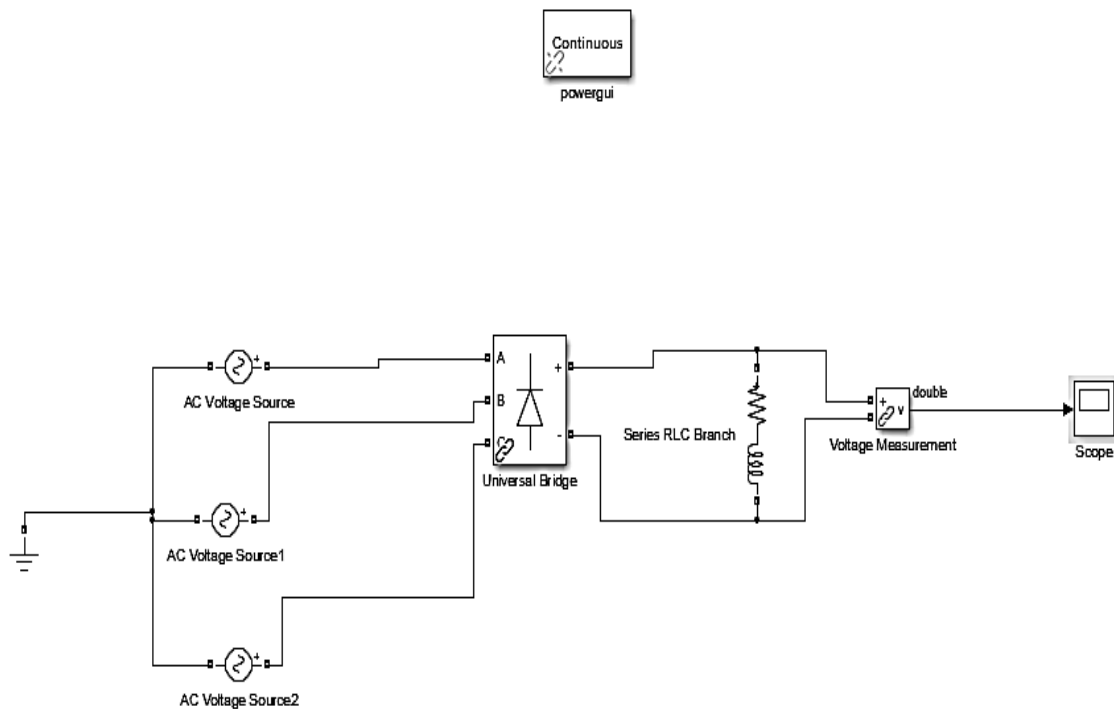

FIGURE 14: 3 PHASE RECTIFIER DESIGN

The 3-phase output voltages differ by an angle of 120 degree and thus the output displayed in the fig 14 is just an envelope comprising all the three phase voltage.

8.1. GRAPH PLOTTED: VOLTAGE VS TIME

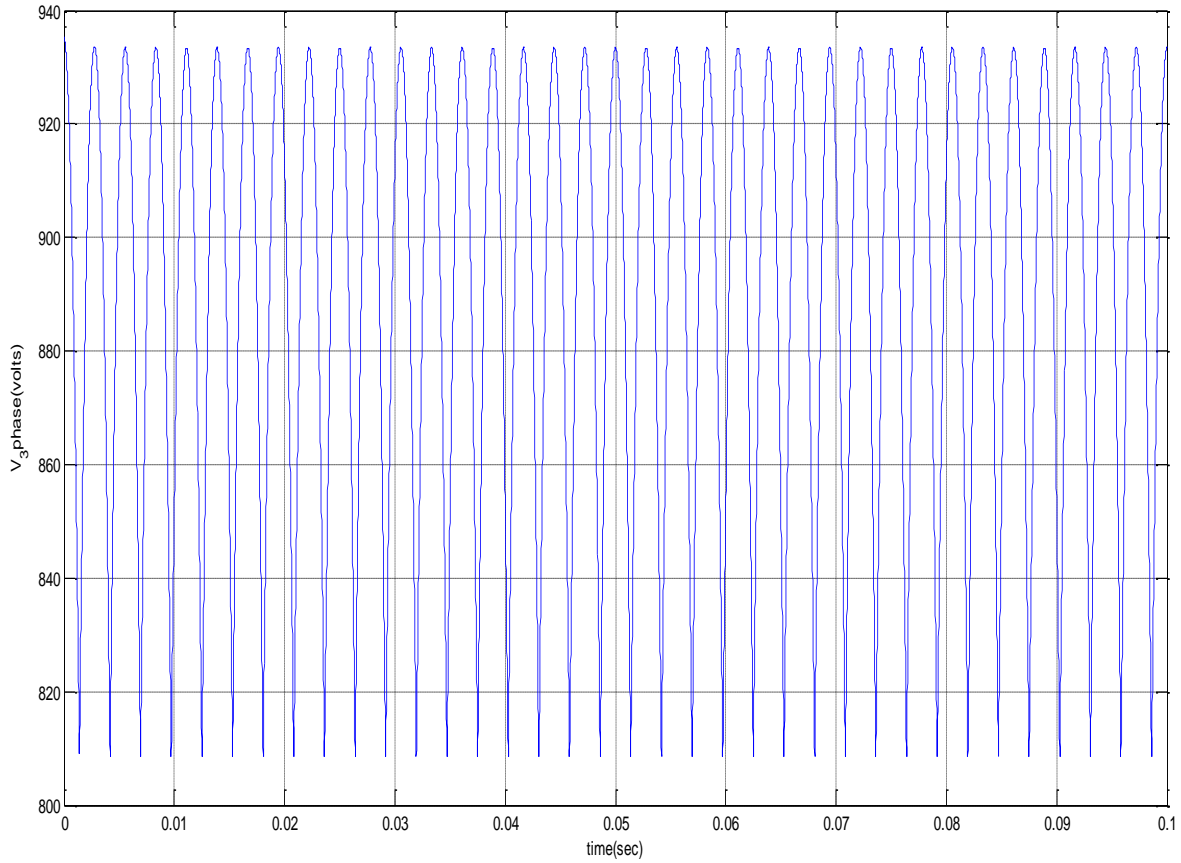

FIGURE 15: 3-PHASE VOLTAGE VS TIME WITH RMS OF 933.5 VOLTS

For 3-phase full wave diode rectifier with no load condition has the following equation:

$$V_{dc} = V_{av} = \frac{3\sqrt{3}V_{peak}}{\pi}$$

$$V_{dc} = V_{av} = \frac{3\sqrt{3}V_{peak}}{\pi} \cos \alpha$$

$$V_{dc} = V_{av} = \frac{3V_{LLpeak}}{\pi} \cos \alpha$$

9. DESIGN OF BUCK AND BOOST CONVERTER FOR THE BASE OF UPS DESIGN

9.1. DESIGN OF RLC FILTER FOR BUCK AND BOOST CONVERTER (CALCULATION OF DUTY CYCLE)

For the design we have to choose the condition at steady state and losses due to switches, inductor and capacitor is neglected for the betterment of the simulation purpose. Another assumption that is taken into mere account is the design does not include the parasitic resistance and the converter is considered to be operating in continuous conduction mode. ($i_L(t) > 0$)

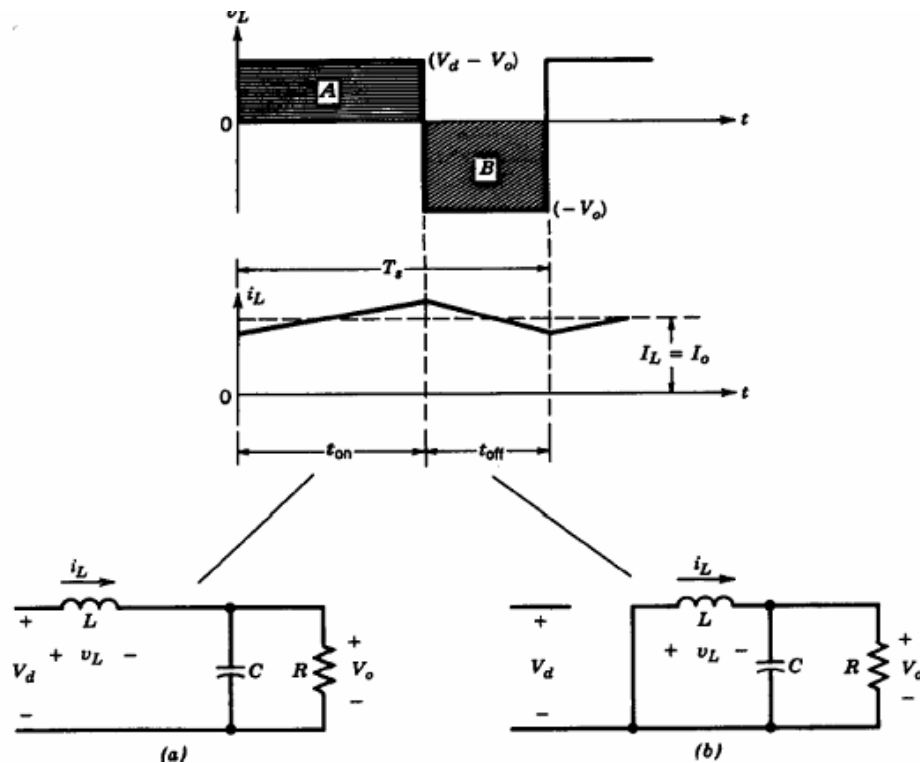

FIGURE 16: BUCK CONVERTER USED IN THE A) SWITCH ON MODE, B) SWITCH OFF MODE

Now, when the switch is in on-state the diode remains off and current starts to build across the inductor and slowly voltage starts to develop across the load as well. The conduction is for the time period denoted as t_{ON} . Thus as a result the voltage developed across load is given as indicated in the above figure is,

$$v_L = V_d - V_0$$

when the switch is turned off then the switch is disconnected so now the current flows to the diode as inductor current can't be made instantaneously zero so direction of current remains same but the voltage polarity is reversed and now the voltage at the output tends to reduce and given as,

$$v_L = -V_0$$

The graphs depicts a triangular behaviour but in practicality it has exponential shape but due to our consideration of time constant to 5 times less than the total time period of its on and off state so it looks somewhat like triangle ($\tau \ll 5 * T_s$).

At steady state the operation repeats itself and over 1 period the voltage across inductor will be zero. Thus from Fig. 12 it is clear that the areas of A and B are equal so,

$$(V_d - V_0)t_{ON} = V_0(T_s - t_{ON})$$

$$\frac{V_0}{V_d} = \frac{t_{ON}}{T_s} = \mathbf{D \text{ (duty cycle)}}$$

Thus, from the derivation it is quite clear that the output voltage does not depends on the input voltage and the other parameters related to the circuit.

9.2. INDUCTOR DESIGN USING MATHEMATICAL CALCULATION

Voltage across load and the capacitor is almost constant due to our assumption of ($\tau \ll 5 * T_s$) and thus differential equation can be written in terms of current flowing through the inductor when the switch

$$L \frac{di_L(t)}{dt} = V_d - V_0$$

Prior to closing of switch, there is some current denoted as $I_{L,min}$ and the time period for its on state is $0 < t < T_{ON} = DT$

$$i_L(t) = \frac{V_d - V_0}{L} t + I_{L,min}$$

The maximum value of inductor current denoted by $I_{L,max}$ as $t \rightarrow T_{ON} = DT$

$$I_{L,MAX} = \frac{V_d - V_0}{L} DT + I_{L,min}$$

Respective peak to peak value of current is represented as ΔI_L ,

$$\Delta I_L = I_{L,max} - I_{L,min} = \frac{V_d - V_0}{L} DT$$

From the above equation, it is clearly seen that the ripple current is directly proportional to the duty cycle and inversely proportional to inductance thus it can be said that we can control the ripple current by varying the amount of inductance as the duty cycle is not in our control due to diverse requirement of the voltages.

Analysis of ripple current for the OFF-state of switch Matlab/Simulink,

Period, $0 < t < T_{off}$

$$L \frac{di_L(t)}{dt} = -V_0$$

Differential solution of the above equation is given as,

$$i_L(t) = -\frac{V_0}{L} t + I_{L,max}$$

Where, $I_{L,max}$ represents maximum value of inductor current at the point when switch is just disconnected.

As, $t \rightarrow T_{OFF} = (1-D) T_s$, the value of inductor current decrease to $I_{L,min}$

Now the value of ripple current in OFF-state is given as

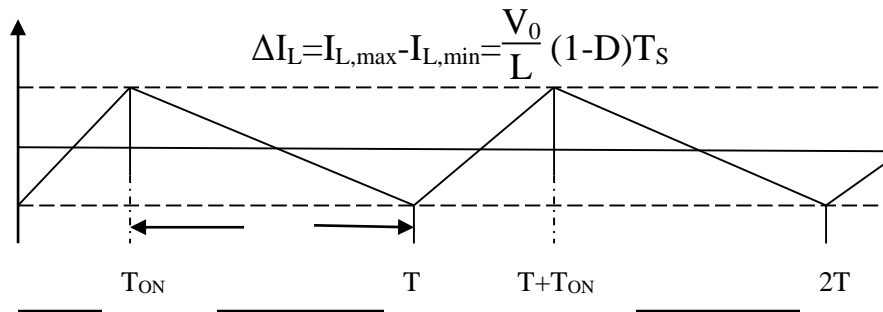

FIGURE 15.1: INDUCTOR CURRENT

The graph for the on time and off time of the circuit is given as in the above equation and the graph is drawn in the figure 15.1. The average current in the conductor must be same as that of dc current through it. So, the equation representing it is as follows,

$$I_{L,avg}=I_0=\frac{V_0}{R}$$

Now, the equation of minima and maxima current through inductor may be represented as,

$$I_{L,max}=I_{L,avg}+\frac{\Delta I_L}{2}=\frac{V_0}{R}+\frac{V_0}{2L}(1-D)T$$

$$I_{L,min}=I_{L,avg}-\frac{\Delta I_L}{2}=\frac{V_0}{R}-\frac{V_0}{2L}(1-D)T$$

Thus, it is clearly proved that the current varies from minima to maxima as per the equation given above during the time switch is closed and is zero otherwise as shown in figure 15.2.

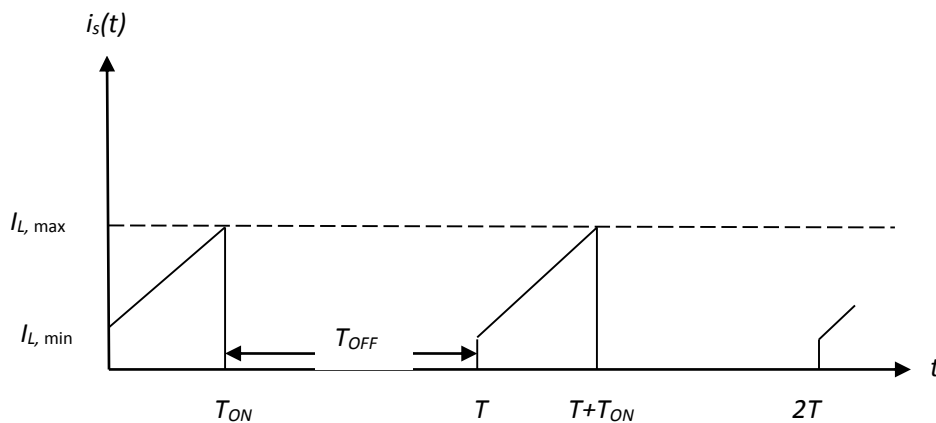

FIGURE 15.2: THE SOURCE CURRENT

When the switch, capacitor and inductor is taken as ideal then the average power dissipated is zero and thus the average power dissipated is only through load. Now, the conservation of power is to be satisfied, so the power supplied by supply is equal to the power dissipated by the load. Thus,

$$V_d I_d = V_0 I_0 = D V_s I_0$$

The equation help us to represent average source current in terms of average load current as

$$I_s = DI_0$$

We know that a buck converter can operate in either a continuous or discontinuous mode. So, when it operates in continuous conduction mode then there is always a current that is flowing in the inductor. Thus, there is a minimum value of inductor that completely confirms that it in continuous conduction mode. And, it can derived by setting $I_{L,\min}$ to zero,

$$\frac{V_0}{R} - \frac{V_0}{2L_{\min}} (1-D)T = 0$$

Which gives,

$$L_{\min} = \frac{(1-D)}{2} RT = \frac{(1-D)}{2f} R$$

The above given value of inductor is used in the design of l filter of buck converter which forms a part of the UPS.

9.3. CALCULATION FOR THE VALUE OF CAPACITOR

The output capacitor is taken as large one so, as to get output voltage as $v_0(t) = V_0$. The work of the capacitor is to block the DC value and thus, the ac which is the ripple is reduced at the output i.e. across load, so less variation occurs at the output. Thus, we can say that all ripple component flows through the capacitor and average value flows through the respective load taken into consideration.

Therefore, peak to peak ripple voltage across capacitor can be written as,

$$\Delta V_0 = \frac{\Delta Q}{C} = \frac{1}{C} \frac{1}{2} \frac{\Delta I_L}{2} T_s$$

And, when the switch is off,

$$\Delta I_L = \frac{V_0}{L} (1-D)T_s$$

Therefore, solving the above two equation we have,

$$\Delta V_0 = \frac{T_s}{8C} \frac{V_0}{L} (1-D)T_s$$

Finally the ratio of the ripple voltage to the actual voltage is represented as,

$$\frac{\Delta V_0}{V_0} = \frac{1}{8} \frac{T_s^2 (1-D)}{LC} = \frac{\pi^2}{2} (1-D) \left(\frac{f_c}{f_s}\right)^2$$

Where f_s stands for switching frequency

$$f_c = \frac{1}{2\pi\sqrt{LC}}$$

Thus, we can clearly see that the ripple can be minimized using a corner frequency $f_c \ll f_s$.

10. DESIGN OF BUCK CONVERTER WITH REQUIRED LC FILTER DESIGN USING SIMULINK

Buck converter has been designed with accurately choosing the L and C values as per the duty cycle requirement. And, special care has been taken so as to avoid the ripple factor associated with the circuit. As, we know that the capacitor is a DC blocker and so all the ripple will pass through it and the DC voltage will appear across load that has resistance of SMES. This circuit has a duty cycle of 50 percent and thus the output is around the half of input.

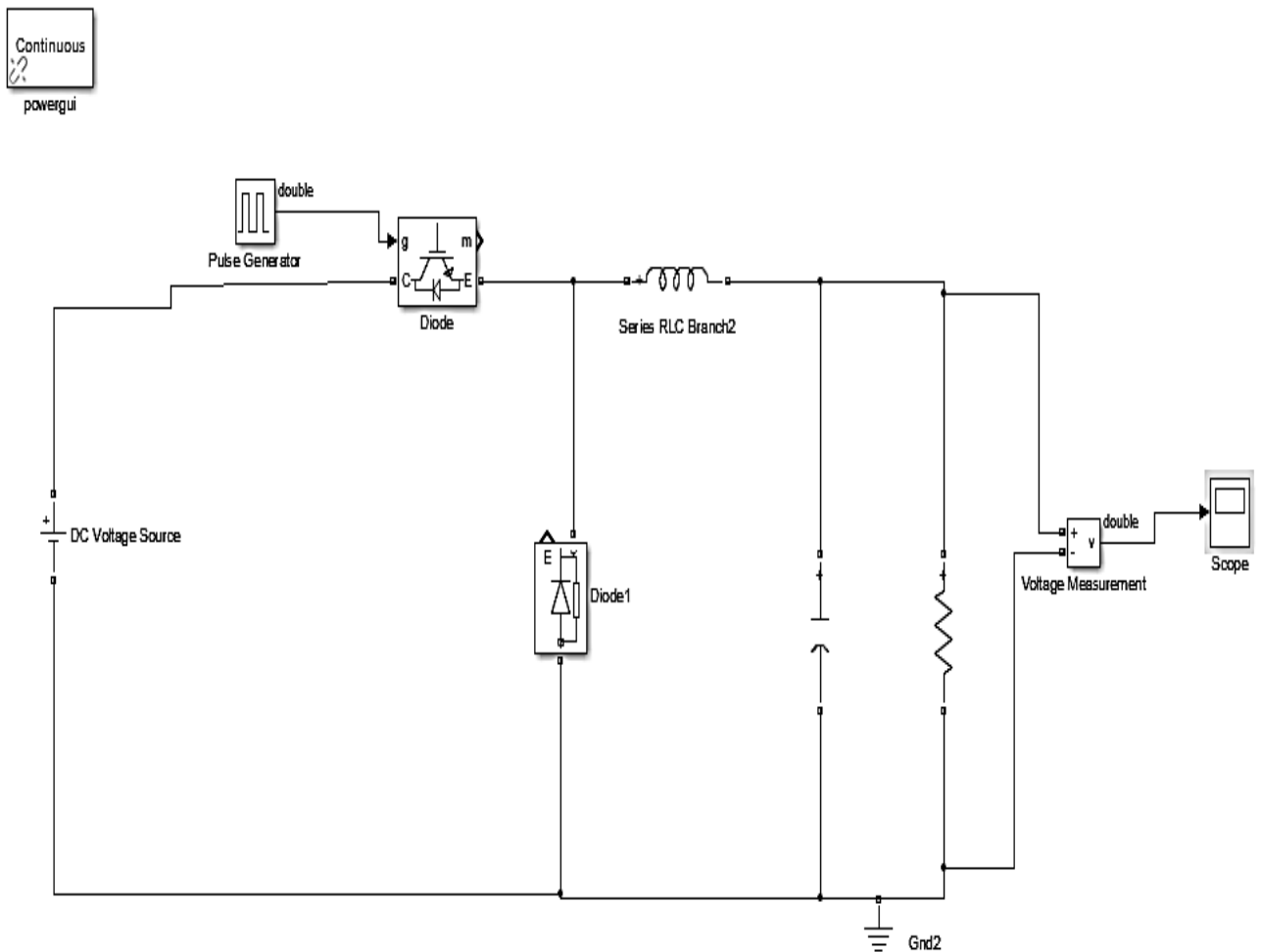

FIGURE 17: VOLTAGE ACROSS THE BUCK CONVERTER HAS BEEN MEASURED USING A VOLTAGE MEASUREMENT DEVICE

Result of the above circuit design in MATLAB/Simulink has been shown in Fig.16 and the graph clearly shows that the design of filter supports the reasoning as the ripple has been minimized.

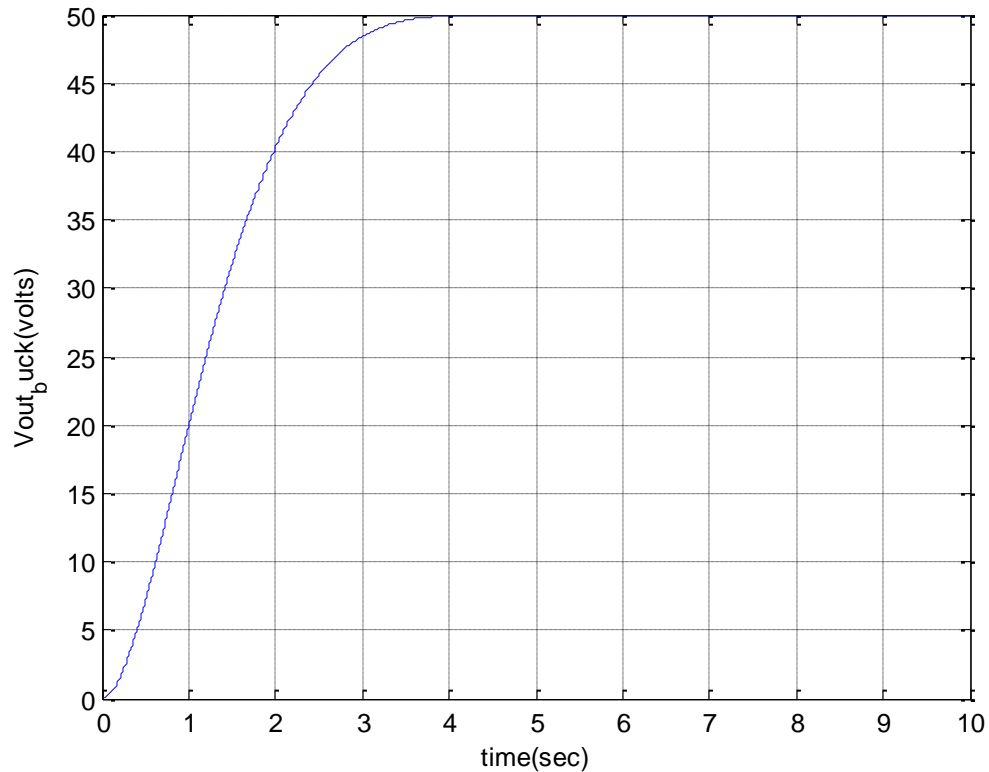

FIG 16: GRAPH OF BUCK CONVERTER THAT HAS BEEN STABILIZED AT 50 VOLTS WITH INPUT BEING APPLIED TO 100 VOLTS WITH ALMOST ZERO RIPPLE.

DATA FOR LC DERIVED FROM THE FORMULA THAT HAS BEEN USED IS AS FOLLOWS:

Assumption as per requirement and as per given:

1. Resistance=0.1 ohm
2. Frequency =50 hertz
3. f_s = switching frequency=5 hertz

Now, applying the formula for the minimum inductance that will stabilize the ripple generated in the Buck converter;

$$L_{\min} = \frac{1-D}{2} RT;$$

Where,

D=Duty cycle;

R=Resistance;

T=Temperature;

L_{\min} = Minimum Inductance for stabilization

$$L_{\min} = 5 * 10^{-4} \text{ Henry}$$

Similarly, from this Capacitance comes out to be: $200 * 10^{-6}$ farad.

11. DESIGN OF PWM-CONVERTER CIRCUIT MODEL IN MATLAB/SIMULINK

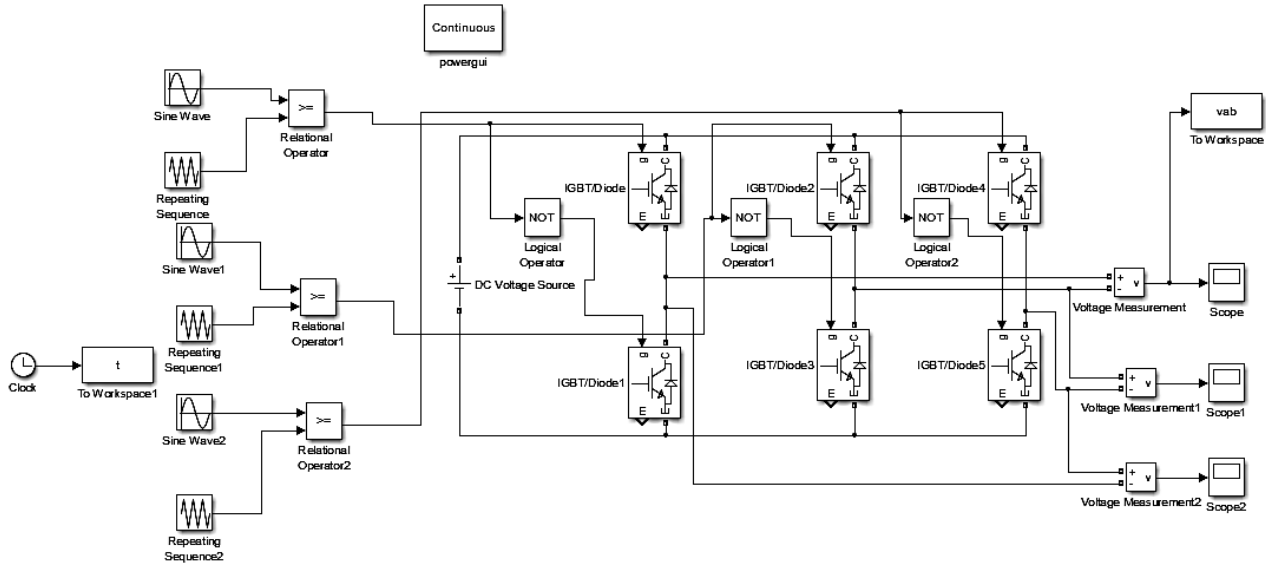
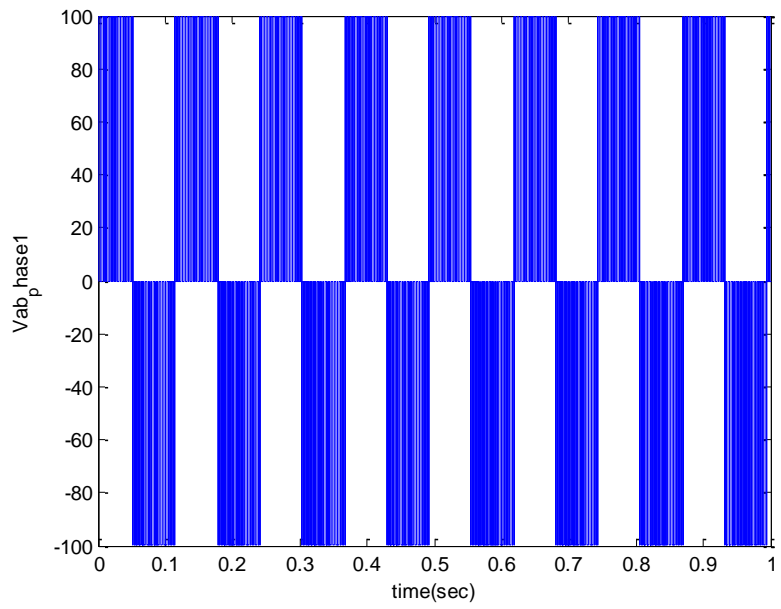
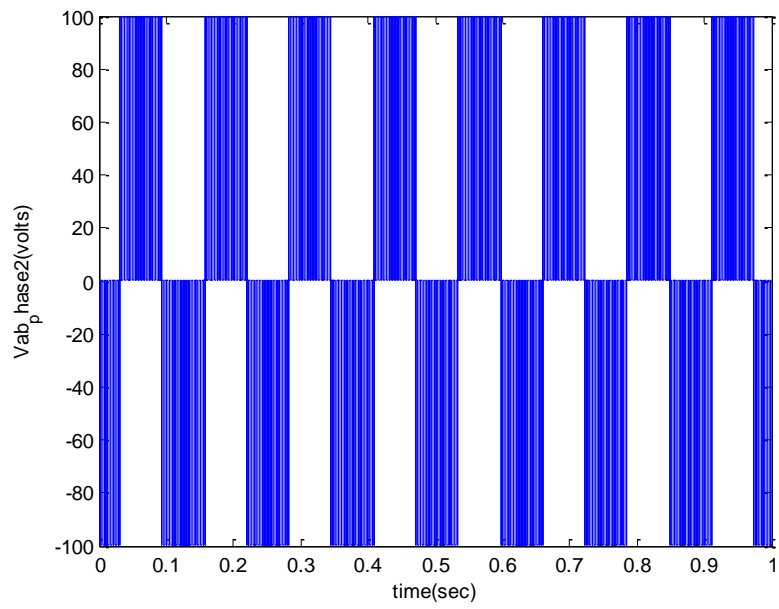

FIGURE 18: DESIGN OF PWM CIRCUIT WITH 50 HZ FREQUENCY AND SWEEPING FREQUENCY IS TAKEN AS 0.5 HERTZ

The Fig. 17 simulation is of PWM-Converter which generates a pulse which is 3-phase, as we have designed a 3-phase converter. The frequency taken into consideration is 50 Hz and the sweeping frequency is 18 times less than household frequency which is taken into consideration. And the output of the above graph has been displayed in the Fig. 18, 19 & 20 which clearly shows that the 3 output pulses are 120 degree out of phase with one another. The first graph is taken as the reference in Fig. 18 and accordingly, 120 degree and -120 degree is the phase of the other two outputs as shown in the figure.



(a)



(b)

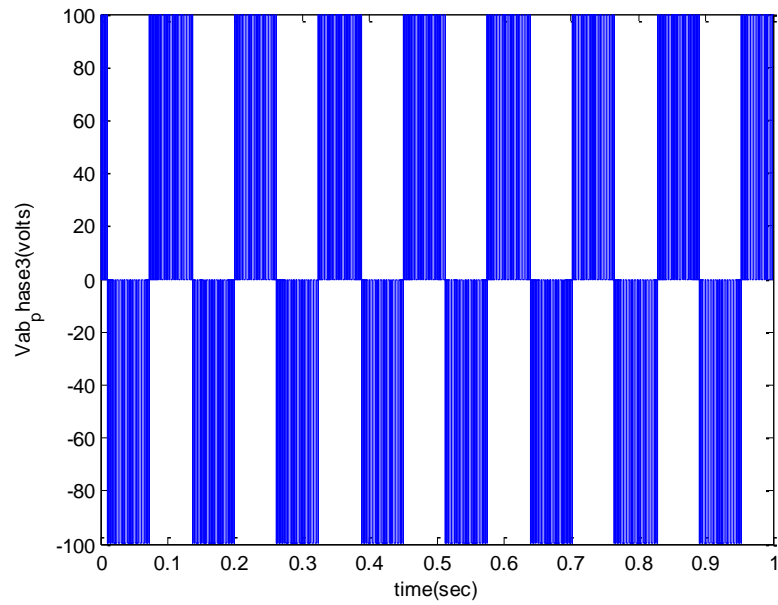

(c)

FIGURE 19: GRAPH OF DIFFERENT PHASE MATLAB/SIMULINK (A) 0° DEGREE PHASE, (B) -120° DEGREE PHASE AND (C) 120° DEGREE PHASE SHIFT AS THE OUTPUT OF PWM CONVERTER

12. DESIGN OF OPEN LOOP CIRCUIT OF UPS (WITH DC OUTPUT, INVERTER OUTPUT AND LOAD OUTPUT)

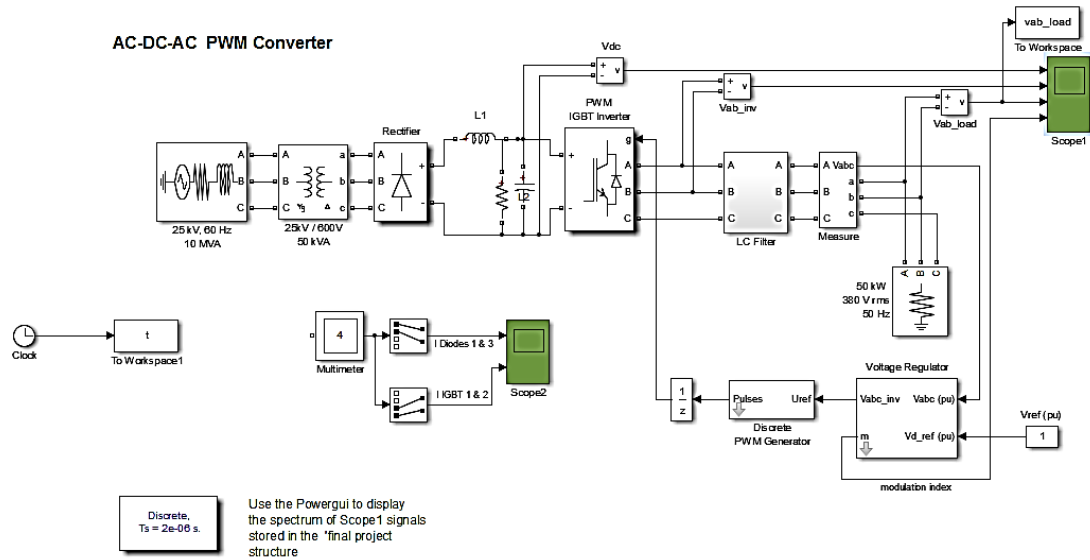

FIGURE 20: DESIGN OF OPEN-LOOP UPS CIRCUIT WITH DC-OUTPUT, INVERTER OUTPUT AND LOAD OUTPUT.

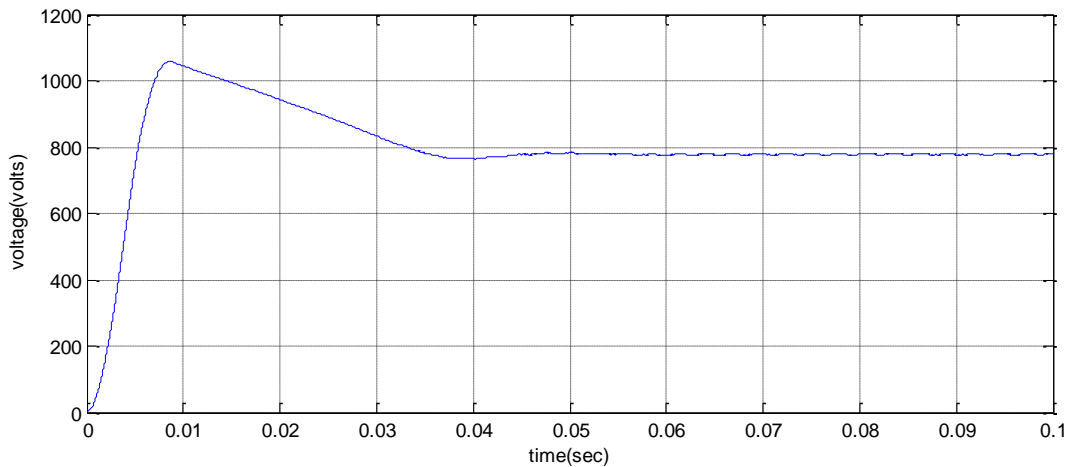

FIGURE 21: GRAPH OF V_{DC}(VOLT) VS TIME (SEC)

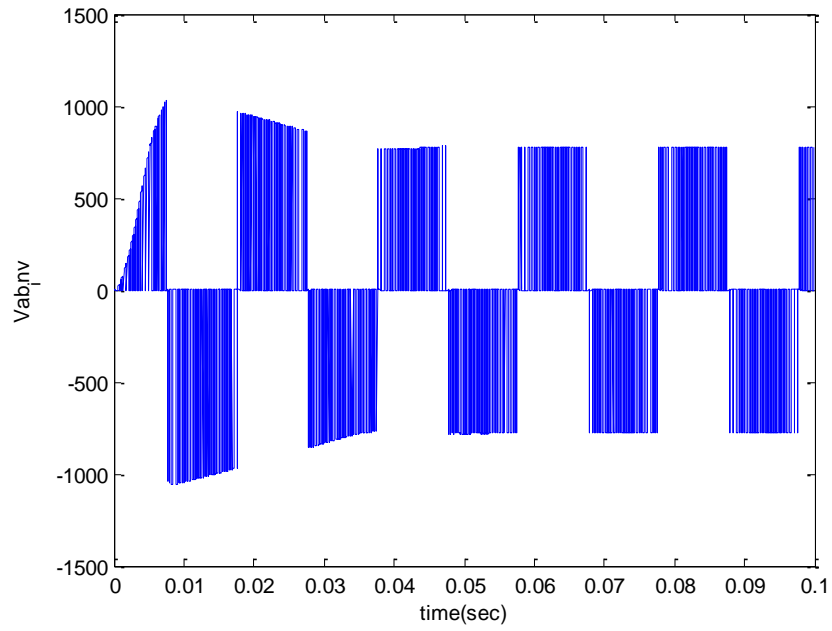

FIGURE 22: GRAPH OF VAB_INV (VOLT) VS TIME (SEC)

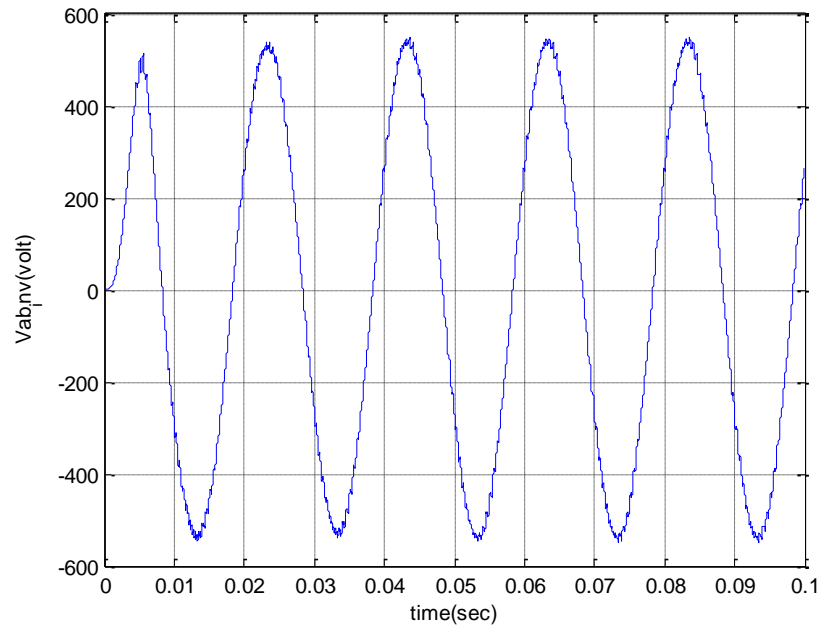

FIGURE 23: GRAPH OF VAB_LOAD (VOLTS) VS TIME (SEC)

12.1. EXPLANATION OF THE CIRCUIT THAT HAS BEEN DESIGNED IN THE MATLAB/SIMULINK

The first phase is a design of charging and discharging circuit so, as to see for the time period and graph analysis from the Simulink. From the simulation it was clear that the time period for which discharging occurred was more for SMES-HTS inductor in comparison to that of copper conductor.

Second phase dealt with the design of 3-phase rectifier where we need to design LC filter which has to be ripple free and accurate. And, use of SMES resistance of value 1×10^{-6} ohm is taken into account.

Third phase has to be with the design of PWM Converter and accordingly, we have to choose a sweeping frequency for its generation that has value 18 times less than that of the given frequency, as we know that the $f_s \ll f_T$, where f_T is the frequency that is used in India i.e. 50hertz.

Fourth phase that is a design of open Loop UPS circuit where PI controller acts as a regulator which has been used to maintain the voltage at 381 V_{rms} and with frequency 50 Hz at load terminal. The multiplier block is used for commutation purpose.

12.2. OBSERVATION

After a period of around 30 millisecond the transient of the circuit dies out and the steady state is reached. And, the voltage of the DC BUS, inverter and load has been observed on the scope that has been observed in SIMULINK. Their respective graphs has been transported to the WORK-SPACE and has been shown. The harmonics generated by the IGBT- inverter has been filtered out by the LC Filter after 2.5 kHz. And, finally we got the rms voltage as 381 volts.

12.3. CALCULATION OF THE CHOPPED INVERTER VOLTAGE

The value of modulation index is taken as 0.8 and peak value of voltage is taken as 778 volts. The fundamental frequency supplied as 50 Hz. So,

$$V_{ab}=778*.0612*.8=381 V_{rms}$$

13. CONCLUSION

The above design is a Simulink model of the OPEN-LOOP SMES based UPS. The graphs used clearly indicated that the design is helpful as it can store energy for a longer period of time due to the high current density and almost zero resistance. Mainly it is the energy that is been stored in HTS- inductor need to be controlled and then it will help in high efficiency and high amount of stored energy. As a trial has been made in the design in MATLAB/Simulink and thus in near future its prototype can be developed.

14. REFERENCES

- [1] J. X. Jin, Z. G. Wang, J. Wen, Y. G. Guo, and J. G. Zhu, "High temperature superconducting energy storage techniques," *Journal of the Japan Society of Applied Electromagnetics and Mechanics*, vol. 15, Supplement, pp. 108-111, Sept. 2007.
- [2] Buck, D. D. S. (2013). AND9135/D. LC Selection Guide for the DC-DC Synchronous Buck Converter.
- [3] A. Kawagoe, S. Tsukuda, F. Sumiyoshi, T. Mito, H. Chikaraishi, T. Baba, M. Yokota, H. Ogawa, T. Hemmi, R. Abe, A. Nakamura, K. Okumura, A. Kuge, and M. Iwakuma, "AC losses in a conduction cooled LTS pulse coil with stored energy of 1 MJ for UPS-SMES as protection from momentary voltage drops," *IEEE Transactions on Applied Superconductivity*, vol. 18, no. 2, pp. 783-786, June 2008.
- [4] X. Y. Chen, J. X. Jin, K. M. Ma, J. Wen, Y. Xin, and W. Z. Gong, "High temperature superconducting magnetic energy storage and its power control technology," *Journal of Electric Science and Technology of China*, vol. 6, no. 2, pp. 137-142, June 2008.