

**Experimental investigation of ethanol fueled  
partially premixed compression ignition (PPCI)  
diesel engine**

A  
THESIS SUBMITTED IN PARTIAL FULFILLMENT OF  
THE REQUIREMENTS FOR THE DEGREE OF

**Master of Technology**  
**In**  
**Mechanical Engineering**  
(Specialization: Thermal Engineering)

By  
**PAWAN KUMAR TIWARI**  
ROLL NO 212ME3323



**DEPARTMENT OF MECHANICAL ENGINEERING**  
**NATIONAL INSTITUTE OF TECHNOLOGY**  
**ROURKELA 769008**

2014

**Experimental investigation of ethanol fueled  
partially premixed compression ignition (PPCI)  
diesel engine**

A  
THESIS SUBMITTED IN PARTIAL FULFILLMENT OF  
THE REQUIREMENTS FOR THE DEGREE OF

**Master of Technology**  
**In**  
**Mechanical Engineering**  
(Specialization: Thermal Engineering)

By  
**PAWAN KUMAR TIWARI**  
ROLL NO 212ME3323

*Guided by*  
**Dr. S. MURUGAN**



**DEPARTMENT OF MECHANICAL ENGINEERING**  
**NATIONAL INSTITUTE OF TECHNOLOGY**  
**ROURKELA 769008**

2014



**NATIONAL INSTITUTE OF TECHNOLOGY  
ROURKELA (INDIA)**

**CERTIFICATE**

This is to certify that the thesis entitled, “**Experimental investigation of ethanol fueled partially premixed compression ignition (PPCI) diesel engine**” submitted by **Mr. Pawan Kumar Tiwari** in partial fulfilment of the requirements for the award of Master of Technology in Mechanical Engineering with Thermal Engineering specialization during session 2013-2014 in the Department of Mechanical Engineering, National Institute of Technology, Rourkela.

It is an authentic work carried out by him under my supervision and guidance. To the best of my knowledge, the matter embodied in this thesis has not been submitted to any other University/Institute for the award of any Degree or Diploma.

**Date:**  
**Place: Rourkela**

**Dr. S. Murugan**  
**(Associate Professor)**  
**Department of Mechanical Engineering**  
**National Institute of Technology, Rourkela**  
**Odhisra, India**

## **ACKNOWLEDGEMENT**

First and foremost I record my sincere gratitude and respect towards my project supervisor, **Dr. S. MURUGAN**, Associate professor, Department of Mechanical Engineering, for his valuable guidance, valuable suggestions and endless support during my study. He has not only been a wonderful supervisor, but also a genuine person. I consider myself extremely lucky to be able to work under guidance of such a dynamic personality. This thesis was made possible by his patience and persistence.

After the completion of this thesis, I experience the feeling of achievement and satisfaction. Looking into the past I realize how impossible it was for me to succeed on my own. I wish to express my deep gratitude to all those who extended their helping hands towards me in various ways during my short tenure at NIT Rourkela.

I also express my sincere thanks to **Prof. K.P. MAITY, HOD, Department of Mechanical Engineering, Prof. R.K. SAHOO, Professor and group head, Thermal Engineering Specialization** and also the other staff members of Department of Mechanical Engineering, NIT Rourkela, for providing me the necessary facilities that was required to conduct the experiment and completion of my thesis.

I also express my special thanks to our research scholar **Mrs. HARI SHANKAR BENDU, Mr. ABHISHEK SHARMA** and my batch mates **Mr. CHUNESHWAR LAL VERMA, Mr. SANDEEP SAHU** and **Mr. ABHISHEK KUMAR SINGH** for their support during my experimentation. I also express my deep thanks to our lab instructor **Mr. N.P. BARIKI** and **Mr. N.K. BISOI** for their help and encouragement.

I am especially indebted to my parents for their love, sacrifice, and support. They are my first teachers after I came to this world and have set great examples for me about how to live, study and work.

**DATE:**

**PAWAN KUMAR TIWARI**

## ABSTRACT

Control of emissions from IC engines applies a huge pressure to engine manufacturers. Low temperature combustion concepts such as HCCI, PPCI, and PCCI are promising solutions for reduction of both the NO<sub>x</sub> and soot particulate from diesel engine. In the present investigation, five different flow rates 0.21, 0.37, 0.51, 0.59 and 0.80 kg/hr of ethanol is injected by port fuel injection. This study investigates the effect of ethanol premixed fraction on PPCI and direct injection combined combustion mode engine. The motivation of using ethanol fuel is that, it can be obtained from both natural and manufactured resources. The combustion, performance and emission parameter are evaluated for all loads with different premixed fractions and compared with diesel fuel operation. Based on the performance and emission parameters, it is understood that the injection of ethanol limits the stable operation range for different ethanol premixed fractions. In order to increase stable operation range, charge heating is used with different flow rates of ethanol. Results indicated that charge heating is beneficial solution for low load operation. For all stable operation range, the NO<sub>x</sub> emission is found to be extremely low than that of diesel, however, the HC and CO emissions are relatively high.

**KEYWORDS** – Premixed fraction, homogeneous, HCCI, combustion, NO<sub>x</sub>, temperature.

# CONTENTS

CERTIFICATE .....	iii
ACKNOWLEDGEMENT.....	iv
ABSTRACT.....	v
CONTENTS.....	vi
LIST OF TABLES.....	ix
LIST OF FIGURES.....	x
NOMENCLATURE.....	xiii
CHAPTER 1: INTRODUCTION	
1.1 General .....	2
1.2 Energy scenario of petroleum products in India .....	2
1.3 Need of alternative technologies and alternative fuels.....	3
1.3.1 Depletion of fossil fuel .....	3
1.3.2 Emission.....	3
1.3.2.1 Unburned hydrocarbon (HC) emission.....	3
1.3.2.2 Carbon monoxide (CO) emission.....	4
1.3.2.3 Oxides of nitrogen (NOX).....	4
1.3.2.4 Particulate matter.....	4
1.3.3 Effects of air pollutants.....	4
1.3.3.1 Global warming.....	4
1.3.3.2 Acid rain.....	5
1.3.3.3 Smog .....	5
1.3.3.4 Health hazards .....	5
1.3.3 Availability of renewable resources.....	6
1.3.4 Technology innovation.....	7
1.4 Aternative fuels for CI engines.....	7

1.4.1	Solid fuels.....	7
1.4.2	Liquid fuels.....	8
1.4.2.1	Alcohol.....	8
1.4.2.2	Methanol.....	8
1.3.2.3	Ethanol.....	9
1.3.2.4	Biodiesel.....	9
1.4.3	Gaseous fuels.....	10
1.4.3.1	Hydrogen.....	10
1.5	Combustion of SI engine.....	10
1.6	Combustion of CI engine .....	10
1.7	Homogeneous charge compression ignition (HCCI).....	11
1.8	Features of HCCI combustion.....	11
1.9	PPCI concept.....	12

## CHAPTER 2 : LITERATURE REVIEW

## CHAPTER 3 : EXPERIMENTATION

3.1	Fuel selection for the study.....	22
3.2	Fuel properties.....	22
3.3	Description of the test engine.....	23
3.4	Experimental procedure.....	24
3.5	Premixed fraction.....	24
3.6	Engine modification.....	24
3.6.1	Port fuel injection system.....	24
3.6.2	Air pre-heater system.....	26
3.7	Schematic layout.....	26
3.8	Uncertainty Analysis.....	27

## CHAPTER 4 : RESULT AND DISCUSSION

### Module 1

4.1	Combustion characteristics.....	30
4.1.1	Pressure CA diagram at full load.....	30
4.1.2	Heat release rate CA diagram at full load.....	31
4.1.3	Pressure CA diagram at medium load.....	32
4.1.4	Heat release rate CA diagram at medium load.....	32
4.1.5	Pressure CA diagram at low load .....	33
4.1.6	Heat release rate CA diagram at low load .....	34

4.1.7	Ignition delay.....	34
4.1.8	Peak cylinder pressure.....	35
4.1.9	Maximum heat release rate.....	36
4.1.10	Combustion duration.....	37
4.2	Performance characteristics.....	37
4.2.1	Brake specific energy consumption.....	37
4.2.2	Exhaust gas temperature.....	38
4.3	Emission characteristics.....	39
4.3.1	Carbon monoxide (CO) emission.....	39
4.3.2	Carbon dioxide (CO <sub>2</sub> ) emission.....	40
4.3.3	Unburned Hydrocarbon (HC) emission.....	40
4.3.4	Nitric oxide (NO) emission.....	41
4.3.5	Smoke opacity.....	42

## Module 2

4.4	Combustion characteristics.....	43
4.4.1	Pressure CA diagram.....	43
4.4.2	Heat release rate CA diagram.....	44
4.4.3	Ignition delay.....	44
4.4.4	Peak cylinder pressure.....	45
4.4.5	Maximum heat release rate.....	46
4.4.6	Combustion duration.....	46
4.5	Performance characteristics.....	47
4.5.1	Brake specific energy consumption.....	47
4.5.2	Exhaust gas temperature.....	48
4.6	Emission characteristics.....	48
4.6.1	Carbon monoxide (CO) emission.....	48
4.6.2	Carbon dioxide (CO <sub>2</sub> ) emission.....	49
4.6.3	Unburned Hydrocarbon (HC) emission.....	50
4.6.4	Nitric oxide (NO) emission.....	50
4.6.5	Smoke opacity.....	51

## CHAPTER 5: CONCLUSION AND FUTURE WORK

5.1	Conclusion .....	53
5.2	Future Work.....	54

REFERENCES.....	55
-----------------	----



## LIST OF TABLES

Table. No.	Description	Page no.
<b>1.1</b>	Adverse effects of principal pollutants	6
<b>3.1</b>	Comparison of Ethanol and Diesel	22
<b>3.2</b>	Technical data of single cylinder engine	23
<b>3.3</b>	Error analysis of instruments	27

## LIST OF FIGURES

Fig. No.	Description	Page. NO.
<b>1.1</b>	Domestic production of petroleum products	2
<b>1.2</b>	Comparison of SI, CI and HCCI combustion	11
<b>3.1</b>	Fuel premixing system	25
<b>3.2</b>	Intake air pre-heating system.	26
<b>3.3</b>	Schematic layout of experimental set up	26
<b>3.4</b>	Photographic view of experimental setup	28
<b>4.1</b>	Variation of cylinder pressure with crank angle at full load	30
<b>4.2</b>	Variation of heat release rate with crank angle at full load	31
<b>4.3</b>	Variation of cylinder pressure with crank angle at medium load	32
<b>4.4</b>	Variation of heat release rate with crank angle at medium load	33
<b>4.5</b>	Variation of cylinder pressure with crank angle at low load	33
<b>4.6</b>	Variation of heat release rate with crank angle at low load	34
<b>4.7</b>	Variation of ignition delay with premixed fraction	35
<b>4.8</b>	Variation of peak cylinder pressure with premixed fraction	35
<b>4.9</b>	Variation of maximum heat release rate with premixed fraction	36
<b>4.10</b>	Variation of combustion duration with premixed fraction	37

<b>4.11</b>	Variation of BSFC with premixed fraction	38
<b>4.12</b>	Variation of exhaust gas temperature with premixed fraction	38
<b>4.13</b>	Variation of carbon monoxide with premixed fraction	39
<b>4.14</b>	Variation of carbon dioxide with premixed fraction	40
<b>4.15</b>	Variation of unburned hydrocarbon with premixed fraction	41
<b>4.16</b>	Variation of nitric oxide with premixed fraction	41
<b>4.17</b>	Variation of smoke opacity with premixed fraction	42
<b>4.18</b>	Variation of cylinder pressure with crank angle at 2.2 kW load	43
<b>4.19</b>	Variation of heat release rate with crank angle at 2.2 kW load	44
<b>4.20</b>	Variation of ignition delay with premixed fraction	45
<b>4.21</b>	Variation of peak cylinder pressure with premixed fraction	45
<b>4.22</b>	Variation of maximum heat release rate with premixed fraction	46
<b>4.23</b>	Variation of combustion duration with premixed fraction	47
<b>4.24</b>	Variation of BSEC with premixed fraction	47
<b>4.25</b>	Variation of exhaust gas temperature with premixed fraction	48
<b>4.26</b>	Variation of carbon monoxide with premixed fraction	49

<b>4.27</b>	Variation of carbon dioxide with premixed fraction	49
<b>4.28</b>	Variation of UHC with premixed fraction	50
<b>4.29</b>	Variation of nitric oxide with premixed fraction	51
<b>4.30</b>	Variation of smoke opacity with premixed fraction	51

# NOMENCLATURE

S.NO	NOTATION	DESCRIPTION
1	AI	Auto ignition
2	IC engine	Internal combustion engine
3	CI	Compression ignition
4	DI	Direct injection
5	TDC	Top dead center
6	bTDC	Before TDC
7	HRR	Heat release rate
8	CA	Crank angle
9	BSFC	Brake specific fuel consumption
10	BSEC	Brake specific energy consumption
11	HCCI	Homogeneous charge compression ignition engine
12	LTC	Low temperature combustion
13	PPCI	Partial Premixed compression ignition
14	PF	Premixed fraction
15	PFI	Port fuel injection
16	ECU	Electronic control unit
17	EGR	Exhaust gas recirculation
18	UHC	Unburned hydrocarbon
19	NO	Nitric oxide
20	CO	Carbon monoxide

# CHAPTER 1

# INTRODUCTION

## 1.1 General

Today, majority of automotive industries manufacture gasoline and diesel engines. Both the engines are contrast to each other in terms of thermal efficiency, fuel economy and emissions. As the population of vehicles increases, there is a huge pressure on the engine manufacturers to apply new technologies which can reduce emissions with a better fuel economy. In an SI engine, the fuel and oxidizer is mixed homogeneously, which reduces soot emissions, so gasoline engines are soot free. But, in order to avoid knocking in them, compression ratio is strictly limited to 10:1. In a CI engine, the fuel is compression ignited and has no throttling losses. Hence, CI engines are superior in terms of power efficiency and fuel economy. But, the oxides of nitrogen ( $\text{NO}_x$ ) and soot are considerable problems for CI engines. In order to reduce emissions and use variety of fuels, there is a need to develop highly efficient and environmental friendly combustion systems.

At present, the main pollutants from IC engines are the  $\text{NO}_x$ , unburned hydrocarbon (HC), carbon mono oxide (CO) and soot. These pollutants are responsible for the local as well as global atmospheric pollution. Therefore, there are laws on emission standards, which limit the amount of each pollutant in the exhaust gas emitted by an automobile engine.  $\text{CO}_2$  is not considered as a pollutant, but it is also responsible for the global warming. It can be reduced only by reducing fuel consumption which can be obtained only by improving engine efficiency.

## 1.2 Energy scenario of petroleum products in India

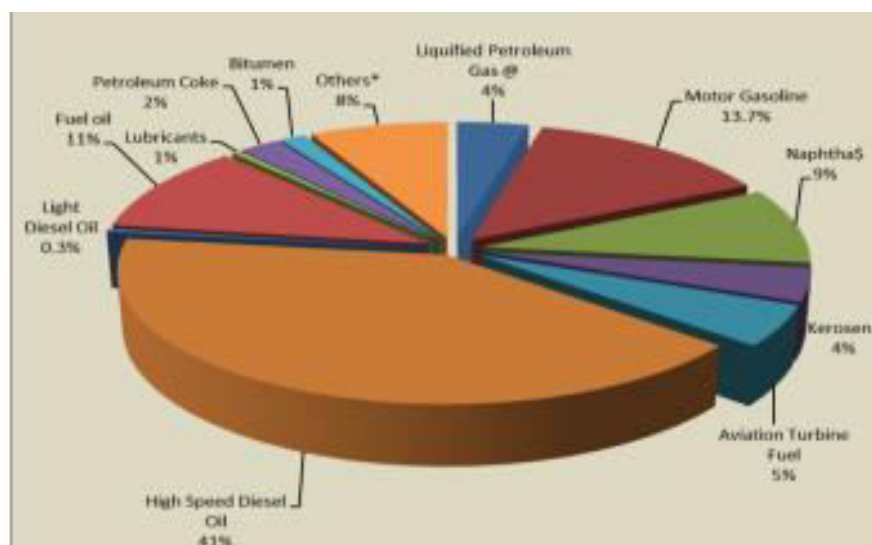

Fig 1.1 Distribution of domestic production of petroleum products in India during 2011-12

Fig 1.1 shows the production of petroleum products in India. According to the Ministry of Statistics and Programme Implementation, Government of India, production of petroleum products report 2013, high speed diesel oil accounted for the maximum share of 41.63%, followed by Motor Gasoline (13.67%), Fuel Oil (9.89%), Naphtha (8.73%), Kerosene (3.8%) and Aviation Turbine Fuel (5.11%). Due to the lower cost of diesel and superior in terms of efficiency, dependency on CI engine increases day by day. In last decade, number of diesel operated vehicles increases as compared to gasoline vehicles.

### **1.3 Need of alternative technologies and alternative fuels**

#### **1.3.1 Depletion of fossil fuel**

Two decades ago, it was forecasted that petroleum and crude oil products will be costly and available with limited reserves. As the population and living standards increase, the number of vehicle increases. Especially transportation heavily depends upon petroleum products. In India, currently about 80% crude oil is imported from foreign countries. Crude oil is a conventional resource which is non-renewable and it takes million of years for new reserves. As a result, day by day cost of gasoline and diesel fuel increases. It will be exhausted in a few years. Since, crude oil requirement increases and the fossil fuel deplete fastly, we will have to switch over to alternatives fuels now and near future. So, in many developing and developed countries scientists engineers and researcher do research on introduction of alternative fuel.

#### **1.3.2 Emission**

Emission is one of the important reasons to inspiring the innovation of alternative fuel technology. It is the serious pollutants from gasoline and diesel engines. A large number of automobiles cause severe air pollution. Some exhaust pollutants get into the atmosphere, they act as irritant, odorant and some are carcinogenic. The different air pollutants are briefly described.

##### **1.3.2.1 Unburned hydrocarbon (HC) emission**

The HC emission is the result of oil film absorption, crevice volume, misfiring condition or incomplete combustion of hydrocarbon fuels. Rich mixture does not have enough oxygen to react with all the carbon and hydrogen, leads to increase in HC emission. Overall equivalence ratio for CI engine is leaner in compare to gasoline engine hence hydrocarbon emission in



compression ignition engine are less than gasoline engine. When hydrocarbon emission gets into the air, they act as irritants and odorants.

### **1.3.2.2 Carbon monoxide (CO) emission**

Reasons for higher CO emission are due to incomplete combustion, heterogeneity of air fuel mixture and temperature rise inside the cylinder. Higher fuel rich mixture leads to carbon monoxide emission during starting or when accelerating under load in the heavy duty vehicles. Not only is CO considered an undesirable emission, but it also represents lost chemical energy.

### **1.3.2.3 Oxides of nitrogen (NO<sub>x</sub>)**

The oxides of nitrogen depend upon availability of oxygen and higher combustion temperature inside the combustion chamber. NO<sub>x</sub> reacts in the environmental gases to form ozone and is one of the major causes of photochemical smog. Development of cyanosis especially at lips, figure and toes, adverse changes in cell structure of lung wall is the long term health effects of oxides of nitrogen.

### **1.3.2.4 Particulate matter**

Particulates are fine solid or liquid particles which are emitted by the vehicles also, may be in solid or liquid phase. Solid particles emitted by vehicles are largely made of carbonaceous matter (soot) consisting a small fraction of inorganic substances Different type of liquid phase substances and other materials are also either adsorbed or absorbed on these particles[1]. The cost of diesel is cheaper than gasoline and therefore in last decade people depended on diesel fuel. Diesel is the more harmful fuel for the reason that it emits ten times more particulate matter per mile than conventional gasoline engines Kinney, P. L. Showed in their study, that particulate matter (PM) dispersed through vehicle emissions and remains suspended at low levels [5].

## **1.3.3 Effects of air pollutants**

### **1.3.3.1 Global warming**

Global warming or green house effect is caused due to accumulation of green house gases at the lower part of earth form a layer, that gases reduce the outward radiation and making earth's climate warm.

CO<sub>2</sub> is one of the main products of automobile exhaust gases, responsible for global warming. This increased temperature affects the natural cycle of weather and changing of climate patterns. Global warming will cause unwanted storms, tsunamis and droughts in plain areas that will lead to crop failures, effect on human life, destroys living and non living things. Unwanted heating melts the glaciers raising the water level of ocean lead to coastal flooding.

#### **1.3.3.2 Acid rain**

Pollutants like sulphur dioxide and oxides of nitrogen react with the water molecule present in atmosphere and form acid. When this acidic substance precipitates in the form of rain or other wet form like snow, cloud water and dew this is called acid rain. Acid rain showed adverse effects on crops, forests, and fresh water, cultivated soil, killed small insects, corrode structures, buildings, bridges, statues. Acid rain lowers the pH value and increases the aluminium concentration of water and soil. The acid precipitation contributes to heart and lung problems including asthma and bronchitis.

#### **1.3.3.3 Smog**

Smog is a type of an air pollutant. Smog is formed by reaction between unburned hydrocarbons and oxides of nitrogen in atmosphere in the presence of ultraviolet radiation. It consists of various organic compounds, ozone and photochemical smog. The harmful constituents of photochemical smog are NO<sub>2</sub>, O<sub>3</sub>, PAN and aldehydes. PAN and aldehydes can cause eye irritation and plant damage [1]. The main problem with this photochemical smog is that, smog traps all the emissions at ground level due to temperature inversion. It is highly toxic and harmful to human health. It can cause severe diseases and long term sickness.

#### **1.3.3.4 Health hazards**

Every impact on our environment directly or indirectly affects human health, on one hand fossil fuel provides a reliable energy for consumers, but the other hand major risk associated with it. Table 1.1 shows the short term and long term adverse effects of principal pollutants.

**Table 1.1** Adverse Effects of principal pollutants (Adapted from B.P. Pundir) [1, 3, 4]

<b>Pollutants</b>	<b>Short- term health effects</b>	<b>Long- term health effects</b>
Oxidants	Difficulty in Breathing, chest tightness, eye irritation	Impaired lung function, increased susceptibility to respiratory function
Ozone	Soreness, coughing, chest discomfort, eye irritation	Development of emphysema, pulmonary edema
Total suspended particulate/ Respirable suspended particulate	Increased susceptibility to other pollutants	Many constituents especially poly-organic matter are toxic and carcinogenic, contribute to silicosis, brown lung
Sulfates	Increased asthma attacks	Reduced lung function when oxidants are present
Nitrogen dioxide	Similar to those of ozone but at a higher concentration	Development of cyanosis especially at lips, fingers and toes , adverse changes in cell structure of lung wall
Carbon monoxide	Headache, shortness of breath, dizziness, impaired judgment, lack of motor coordination	Effect on brain and central nervous system, nausea, vomiting, cardiac and pulmonary function changes, loss of consciousness and death.

### 1.3.4 Availability of renewable resources

Large portion of the world's energy is expected to come from solar, wind, and other renewable resources. These energy sources do not have undesired consequences like dependency on fossil fuels. In India, some places have high temperature, warm environment for example western India and northern India. At these places, solar energy can be harnessed with maximum efficiency. In coastal areas wind power is available. To convert this low grade energy into work, some alternative technologies are required for example fuel cell, solar plates, hybrid vehicles and so on. Now, in cities people prefer electric vehicles that are cheaper than petroleum fueled vehicles. Energy from biomass, wind, solar, geothermal, hydroelectric are renewable and cheaper.

### **1.3.5 Technology innovation**

In early days, research fields and technologies were limited. Researchers faced difficulties to solve complex problems but, now a day technologies become advanced and hence organizations within the academic, industries and R & D conduct large scale and advanced research works. Government and Non-government organisations motivate to adopt latest technologies by giving subsidies and proper knowledge. Marketing is one of the motivators to do research on any product or process

## **1.4 Alternative fuels for CI engines**

In CI engines, chemical characteristic of fuel as well as the functional and design conditions of the engine affect engine combustion, performance and emission parameters. Some important fuel characteristics are as follows;

1. Fuel should have a sufficient volatile for good mixing of charges.
2. Low auto-ignition temperature with high cetane rating.
3. CI engine fuel should have a short ignition lag to reduce knocking.
4. Fuel should not produce either smoke or odour after combustion.
5. For smooth flow of fuel viscosity should be sufficiently low.
6. Fuel should be non corrosive and wear resistance.
7. The fuel should have a high flash and a high fire point.

Conventionally, gasoline and diesel are used in SI and CI engine respectively. But, now introduction of alternative fuels that are not derived from fossil fuels seem to be prominent. The alternative fuel may be a renewable or non-conventional fuel derived from various organic substances that can substitute or replace conventional fuels. That is available in a solid, liquid and gaseous form.

### **1.4.1 Solid fuels**

Now a day, solid fuels are obsolete for IC engines. Before use of petroleum as a fuel, different fuels were tested and tried. Even Rudolf diesel, who is the inventor of diesel engine, used coal dust mixed with water in some of his experiments. Especially, in India coal is a lucrative offer, because of its availability in a large quantity, so research work continues in this technology for the reduction of particle size, changes percentage of water and use some additives.

## **1.4.2 Liquid fuels**

Liquid fuels are easy to storage and have high calorific value. In the liquid fuel category the main alternative fuel is alcohol [2]. The other prominent alternative liquid fuels are biodiesel vegetable oil.

### **1.4.2.1 Alcohol**

Alcohol is obtained from both natural and manufactured sources. That's why alcohols are an attractive alternative fuel. Naturally, it obtained by fermentation process of glucose and manufactured industrially, by hydration reaction. The two most promising form of alcohols are ethanol and methanol.

The main advantages of alcohol are given below:

- High Octane no with antiknock property
- Less exhaust emission than gasoline
- After burning it gives more moles that means higher pressure and more power in expansion stroke.
- Higher latent heat of vaporization
- Low sulphur content in fuel

Alcohols have the following disadvantages:

- Low calorific value almost half of diesel
- Aldehyde emission in the exhaust
- Poor ignition characteristic
- Flammable
- Reduce efficiency of catalytic converter
- Possibility of vapour lock in fuel delivery system

### **1.4.2.2 Methanol**

Maximum research is carried out on methanol, because it is considered as an alternative fuel to gasoline. It has most promising future aspects. It can be obtained from both fossil and renewable sources include coal, petroleum, natural gas, biomass, wood, landfills and oceans. Last decades, many researchers conducted research on pure methanol, mixture of methanol and gasoline. M85 (85% methanol and 15% gasoline) and M10 (10% methanol and 90%

gasoline) combinations is giving good results with saving gasoline and emission reduction, there is a considerable reduction in the HC and CO emissions by using M85. The main problem in methanol and gasoline mixture is immiscibility which results in non homogeneous mixture. This create problem in engine running.

#### **1.4.2.3 Ethanol**

Ethanol is a renewable fuel receiving more attention by many researchers. It has been used for a long time in many countries in the world. Brazil is one of the largest producer of ethanol. In the United States of America also, ethanol and gasohol fuel stations are available. Gasohol is the combination of ethanol with gasoline. Ethanol has important mixture combinations E85 (85% ethanol and 15% gasoline) and E10 (10% methanol and 90% gasoline).

Gasoline mixed with ethanol to eliminate some problem like cold start and tank flammability. A small percentage of ethanol mixed with gasoline can be used in automobile engine without any engine modification. Ethanol obtained naturally by fermentation of grain or sugar, and from the hydrolysis of starch. Ethanol generates less HC emission than gasoline, but more than methanol.

#### **1.4.2.4 Biodiesel**

Biodiesel is produced from the biological tissues of plants and animals. Biodiesel are consisting fat-based long-chain alkyl esters. It gives lower emissions with moderate efficiency. It can be used directly or with diesel blend in CI engine. Some common blends are B100, B20. Biodiesel is capable of used in its pure form with some modification in engine hardware to avoid performance problem. Biodiesel is a cleaner alternative, because it contains no sulphur and no aromatic content. It is rich in oxygen which increases its volumetric efficiency and good combustion. The calorific value of biodiesel varies with the feed stocks material and countries. In India, sources of biodiesel include Jatropha, curcas, karanj, mahua which are non edible in nature. Biodiesel produced from different resources all over world include palm oil, coconut oil, chinese tallow, rapeseed oil, soy oil, peanut oil, sunflower oil and hemp oil. Sunflower, rape seed oil etc., are used as raw materials in Europe, while soya bean is used as a raw material in the U.S, palm oil is used in Thailand and Malaysia, frying oil and animal fats is used in Ireland.

### **1.4.3 Gaseous fuel**

Gaseous fuel can homogeneously mix with air and hence the physical delay is almost zero. It eliminates the accumulation of fuel problem, so better reduction in soot and particulate emission can be observed. In early days, it is very difficult to store and transport gaseous fuel, but now it become easy.

#### **1.4.3.1 Hydrogen**

Hydrogen is a cleaner fuel among all the alternative fuels and hence many automobile manufacturer work on engine design to operate on hydrogen fuel. Because of no carbon atom is present in fuel, there are no CO and HC emissions in the exhaust. It contains high energy per unit volume, when stored in the liquid form. Vehicle can run long without refill the fuel tank. Hydrogen produced easily by electrolysis of water and coal gasification. The most economic process to manufacture hydrogen is from hydrocarbons like natural gas or naphtha by stream reforming. Hydrogen is a good alternative fuel, but till now we are not able to use as source of power due to some reasons as such poor volumetric efficiency, requirement of heavy, bulky fuel storage in vehicles and service station, difficult to refuel and possibility of detonation and high NO<sub>x</sub> emission.

## **1.5 Combustion in SI engine**

In SI engine, fuel and oxidizer is mix homogeneously in the intake manifold by external mixture preparation with the help of carburettor. This mixture enters into the cylinder in suction. After suction fuel and air mixture is compressed together. Since auto ignition temperature of gasoline fuel is high the mixture is ignited by using spark produced by a spark plug. In this type, combustion occurs with a single flame propagation large ignition lag promote antiknock performance.

## **1.6 Combustion in CI engine**

In a CI engine, initially air is compressed with a high compression ratio 16:1 to 20:1 raising its temperature and pressure to the sufficient value of auto ignition for fuel. At that time, fuel is injected in to the cylinder using a high pressure fuel injector. This injected fuel disintegrates into small-small particles surrounded by air in order to promote vaporization. Small liquid droplets absorbing latent heat of vaporization from surrounding air and vaporize. After vaporization temperature further increases. When this reaches to the combustible range,

ignition takes place. Since the fuel droplets cannot be injected and distributed uniformly throughout the combustion space, the fuel-air mixture is essentially heterogeneous. In this type, combustion shorter ignition lag promote antiknock performance. It is necessary to start the actual burning as early as possible after the injection begins.

### 1.7 Homogeneous charge compression ignition (HCCI)

HCCI is a type of combustion in which fuel and air are mixed homogeneously outside the cylinder and then compressed to the point of auto ignition level in compression stroke. The homogeneous charge compression ignition engine incorporates the best features of conventional gasoline and diesel engine. The HCCI engine produces gasoline like soot emission while diesel like power efficiency.

- SI engines: homogeneous charge spark ignition engine (gasoline engine)
- CI engines: stratified charge compression ignition engine (diesel engine)

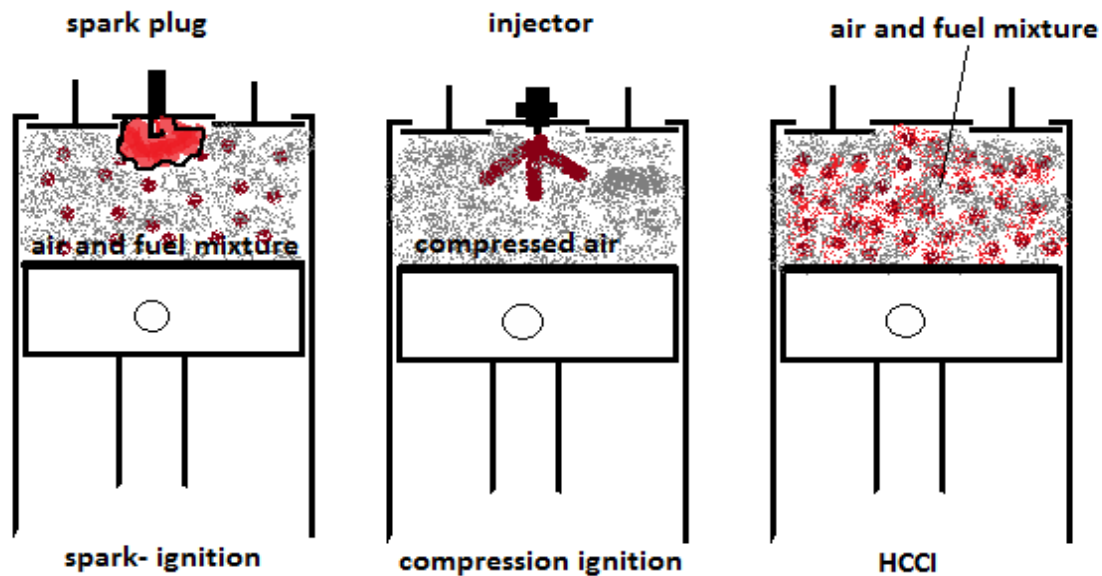

Fig 1.2 Comparison of SI, CI and HCCI combustion

### 1.8 Features of HCCI combustion

- I. Unlike SI engine there is no throttling loss, lean fuel operation and higher compression ratio. Hence, HCCI gives higher power efficiency and superior in fuel economy.



- II. In HCCI combustion, charge is homogeneously mixed, no accumulation of fuel in cylinder, produce less or no soot.
- III. In HCCI combustion, start of combustion occurs when charge is auto-ignited. It completely depends on fuel characteristics, engine properties and atmospheric conditions.
- IV. Since combustion starts instantaneously, there is no flame propagation shorter combustion duration and avoids knocking problem.
- V. In HCCI no more specification of fuel required. HCCI engine is a fuel flexible engine which can be operated by low cetane fuel and several alternative fuels.
- VI. Maximum temperature of cylinder reduces, because of overall cylinder combustion reduces simultaneously and hence lower NO<sub>x</sub> emissions.
- VII. By removing a higher pressure injector and other equipment lower cost of engine can be forecast.
- VIII. The HCCI engine can save 15- 30% fuel practically, while meeting current emission standard.

## **1.9 PPCI concept**

The two main challenges for the HCCI combustion, that is the direct control of combustion and limited operation range due to misfiring at low load and knocking at high load. Partially premixed compression ignition (PPCI) is very useful in order to reduce disadvantages of HCCI especially for a single cylinder engine and enjoys the benefits to operate the engine in dual mode operation. According to this concept, some quantity of fuel is injected by port injection to achieve homogeneity of charge and some quantity of fuel is injected by conventional direct injection to achieve combustion control. By adjusting the quantity of port injected fuel and direct injected fuel the optimum results can be obtained. Several studies have revealed the advantage of similar combined combustion mode. [24, 25, 26]

In this study initially a brief description of commercial diesel engine and technologies related to the engine architecture influencing the combustion process are discussed. The existing conventional diesel engine is converted into PPCI combustion mode. Experiments were conducted in the PPCI mode using ethanol as a premixed fuel.

## CHAPTER 2

# LITERATURE REVIEW

Rakesh Kr Maurya et al. [7] used port fuel injection technique for preparing homogeneous mixture. Twin cylinder engine was converted into HCCI mode in which one cylinder worked on homogeneous charge compression ignition and the left as conventional compression ignition diesel engine. Experiments were performed by altering the intake charge temperature and equivalence ratio at constant speed 1500 rpm in order to achieve the stable HCCI combustion. It was found that stable homogeneous charge combustion was achieved within the range of air-fuel ratio (2.0-5.0). For ethanol, the highest indicated thermal efficiency was found to be 44.78 % and maximum IMEP obtained was 4.3 bar at 2.5 air fuel ratio and 120 °C intake air temperature. The combustion characteristics, combustion efficiency and emissions were also discussed.

Haoyue Zhu et al. [8] conducted an experimental study to the blending of ethanol in biodiesel. Addition of ethanol reduced viscosity, surface tension, where as enhances interaction and wave growth at liquid gas interface. Ethanol and improved spray atomization in order to obtain more homogenous mixture. Engine tests were performed on a one cylinder, based on multi CIDI engine with some modification. They worked for reduction of soot and NO<sub>x</sub> for diesel, biodiesel, and biodiesel–ethanol. In a moderate exhaust gas recirculation (EGR), premixed low temperature combustion (LTC) mode was investigated. The research focused on blended ethanol, enhance fuel and air mixing rate, prolongs ignition delay, increased fuel oxygen from 10.2% to 15.1% as a result of reduction in soot.

Vittorio Manente et al. [9] conducted an experimental study to perform a sweep, in the start of injection of the pilot and pilot-main interaction ratio at high load. A start of injection SOI sweep was carried out in order to understand the most convenient stratification level that maximized the efficiency and minimized the emissions. The experiment was based on a single cylinder DI engine with modification, engine boosted by using compressed air on external air line. Fuel was injected by using Bosch injection system. The fuel used was ethanol (99.5% by volume, heating value 29 MJ/kg). They perform low load analysis and high load analysis at different operating parameter. Results showed that low NO<sub>x</sub>, soot, CO and HC can be achieved when EGR rate varied between 40-47% and air fuel ratio between 1.15 and 1.25. Pilot injections were placed at -60° TDC while pilot main ratio was found to be 50-50. The use of some oxygenate were able to reduce soot production.

J. Hunter Mack et al. [10] investigated the effect of water fraction in ethanol on the HCCI engine operating limits, intake temperature, heat release rate and exhaust emissions. The experiments were conducted on Volkswagen 1.9 L 4 cylinder engine. The liquid fuels were port injected by MSD injector and controlled by MSD software. In all the experiments ethanol fuel flow rates were held constant with varying fraction 100%, 90%, 80%, 60%, and 40% of ethanol in water mixtures, and it was concluded that stable HCCI operation was obtained for fuels containing up to 40% water. Results indicated that by increasing intake heating value, HCCI engine can be operated with high fraction of water in ethanol.

Samveg Saxena et al. [11] focused on the use of wet ethanol, as a fuel for homogeneous charge compression ignition engines. By using exhaust heat recovery to increase the temperature and provide the high input energy required for igniting wet ethanol. As the main cost of ethanol extraction is distillation cost, which increased more for extraction of low amount of water present in fuel. The experiments were conducted on 4 cylinder 1.9L Volkswagen TDI engine at 1800 rpm. In this experimental engine, some modification was done in piston for reducing heat loss. An external High Pressure compressor, with 6m<sup>3</sup> surge tank was provided intake air with precise pressure regulation. Results indicated that the most excellent circumstances for using wet ethanol in an HCCI engine with exhaust heat recovery were with high intake pressure and high equivalence ratio. The utilization of 20% water in fuel is possible, by using exhaust heat recovery while intake pressure at 1.4-2 bar and fuel air ratio 0.25 to 0.55. Hotter intake temperature will caused earlier combustion timing, causing exhaust temperature reduction, which decreased intake temperature, leading to later combustion timing, causing hotter exhaust temperature that further advanced the combustion timing.

D.Ganesh et al. [12] prepared to the mixture outside the combustion chamber. Vaporized diesel fuel was homogeneously mixed with air and introduced into the combustion chamber during intake stroke. They conducted experiments on single cylinder diesel engine with a modification to achieve HCCI mode adding with vaporizer, ECU to control port fuel injection system, exhaust gas recirculation and DAS, fuel metering system and crank angle encoder. First they started engine with conventional mode and the injected fuel externally, such that mechanical governor cuts-off the supply of diesel. In order to control ignition they conducted experiment with diesel vapour induction without EGR and by 10%, 20%, 30%, EGR. Results showed the importance of EGR role in controlling combustion phase. EGR was

used to decrease the cylinder temperature and pressure, that's why combustion phasing is very sensitive for exhaust gas recirculation. EGR plays important role to combustion control and the rate of pressure rise in the combustion chamber. Brake thermal efficiency was decreased with the increase in EGR% reported. The HCCI reduced 90-98% NO<sub>x</sub> but the HC and CO emission was usually around 30% more in comparison to the conventional diesel engine.

Akhilendra Pratap Singh et al. [13] reported that, homogeneous mixing of charges is the very difficult part in diesel fueled HCCI combustion because less volatility of diesel. Therefore they used a device called 'diesel vaporizer' to prepare the homogenous fuel-air mixture. The vaporizer was nothing but a chamber made by copper wounded externally by a band heater that was controlled by PID temperature controller. Experiments were performed at three different relative air-fuel ratios ( $k = 4.95, 3.70$  and  $2.56$ ) while changing EGR percentage. For experiment they used a constant speed, 2-cylinder 4-stroke DI diesel engine. Only one cylinder was modified into HCCI combustion mode, while the other in conventional mode. They discussed the Start of combustion, EGR condition (0, 10%, 20%), efficient HCCI condition, two stage of heat release.

Bahram Bahri et al. [14] focused on the affects of misfire in the exhaust emissions, IMEP, trace heat release and combustion phasing matrix. The useful characteristics for misfire detection in the ethanol fueled homogeneous charge compression ignition engine were discussed. They used ANN model to sense misfire. Experimentally prove capability of model with 100 % accuracy. They have also conducted experiment on a single cylinder 4-stroke, CIDI engine modified into HCCI mode. To facilitate homogeneous charges in cylinder a fuel premixing system, air pre heater (3 KW heater) was placed into intake manifold. The ignition timing, misfire and misfire generation, and burn duration were determined. According to them a cycle was measured a partial misfire when its HRR was decreased by 10% or more and for misfire cycle it was found to be less than 50%. In this work they reported 3-type of misfire, first was fuel unavailability, second was lean air fuel mixture and third was the insufficient temperature. As per the results, ethanol HCCI was responsive to the equivalence ratio, dissimilarity of homogeneous charge combustion matrix. The maximum HRR was found well related to misfire, IMEP. Cyclic SOC, CA<sub>SO</sub>, CA<sub>MHRR</sub> are not effective parameter for misfire detection in HCCI.

Suyin Gan et al. [15] reviewed the functioning of HCCI combustion in CIDI engines, using different types of injection variation with time and crank angle. For example, early injection, multiple injections and late injection strategies, physical variation like injector characteristics, geometry of piston and cylinder, compression ratio, swirl ratio. They reported that homogeneity of charge was the key feature of HCCI and discussed effect of design and operating parameter intake air temperature, EGR on HCCI diesel emission specially  $\text{NO}_x$  and soot on combustion.

L. Starcket al. [16] investigated the quality of fuel for better HCCI performance. Define the HCCI index and fuel matrix. These indexes were based on comparison of tested fuel by reference fuel, here EN590 (cetane no. 51.5) was used as reference fuel. The results indicated that a low cetane number and high volatility fuel with suitable chemical composition would be improve the operational limit of HCCI by greater than 30% without any reduction in the performance under conventional diesel combustion mode. According to them, the most excellent fuel for HCCI performances are reactive compounds and having low cetane no.

Mingfa Yao et al. [17] conducted a study based on fundamental theory of HCCI engine modelling. Five types of numerical simulation models were discussed briefly in order to understand chemical kinetics. HCCI start of combustion and operating range can only controlled by chemical kinetics. They also discussed the challenges of HCCI combustion like operation range, combustion phasing control, cold starting, homogeneous mixture preparation, fuel modification, their effects on chemical kinetics, evaluated control strategies of diesel fuelled HCCI and how they made effect on combustion processes.

Abdul Khaliq et al. [18] in this investigation, they took simple engine used in trucks with some modification. They applied 1<sup>st</sup> and 2<sup>nd</sup> law of thermodynamics combined approach for a homogeneous charge compression ignition engine working on ethanol with water fraction. Numerical analysis was performed to examine the effects of turbocharger compressor ratio, ambient temperature, and compressor adiabatic efficiency on first law efficiency, second law efficiency, and exergy destruction in each component.

P A Lakshminarayanan et al. [19] the rate of combustion was specifically illustrated with the relation of mixing rate to the turbulent energy produced at the end of the nozzle. It is

depends on the injection velocity and by taking into consideration the dissipation of energy in open air and beside the cylinder wall. The complete absence of tuning constants distinguished the model from the other zero-dimensional or pseudo multi-dimensional models.

Onishi S et al. [20] did first time study on HCCI. The experiments were carried out on a 2-stroke gasoline engine. This newly devised combustion system, designated as “Active Thermo-Atmosphere Combustion” (ATAC), it was reported that there is instantaneous combustion different from conventional SI and CI engine combustion processes. He described the regions of formation NO<sub>x</sub> and soot have been conceptualised in an equivalence ratio temperature map.

Annarita Viggiano et al. [21] proposed multi dimensional mathematical approach, together with a kinetic reaction mechanism for ethanol oxidation, NO<sub>x</sub> formation and CO emissions was major issue of his work. This model evaluated turbulent time scale and kinetic timescale by using code and numerical methods. They solved the system of governing equation and optimize result. These pollutants were strictly related to heterogeneity in the cylinder near the surface. This study made understand the feature of HCCI Inhomogeneities in combustion chamber, prediction of ignition delay, thermal chemical properties and their role on performance parameter and emission. They examined emissions, wall heat transfer and temperature inhomogeneties.

Zhang Chun-hua et al. [22] investigated the effect of charge heating and equivalence ratio on HCCI combustion, performance and exhaust emissions. The investigation were carried out on modified HCCI engine fueled with ethanol methanol and gasoline. Results indicated that the sensitivity of ethanol and petrol are high for intake air temperature. Increase in the intake air temperature cause increases in pressure rise. The HC and CO emission decreased with increased air temperature without increased NO<sub>x</sub> for ethanol and methanol, but for gasoline NO<sub>x</sub> also increases. When air-fuel ratio is more than 2.5, the oxides of nitrogen became almost negligible, but the unburned hydrocarbon and carbon monoxide increased in exhaust.

Junjun Ma et al. [23] did experimental work on dual fuel operation called HCCI- DI combustion. N-heptane was injected externally by port injection combine with CIDI engine. The experiment was carried out on single cylinder conventional direct injection compression

ignition engine at constant speed over the range of load by changing premixed ratio. They investigated effect of premixing on combustion characteristic of diesel engine, emission characteristic of HCCI-DI and engine performance on different load. Found that  $\text{NO}_x$  decrease dramatically when premixing initiate and carry on. For low premixing ratio was not affected by soot formation. At higher value of premixing ratio  $\text{NO}_x$  and soot inherently trade off, but assessed in CO and UHC emissions. The result also showed improved the indicated thermal efficiency at low to medium loads.

Dong-bo yang et al. [24] conducted an experimental study on single cylinder CIDI engine. Fuel stratification had a capacity to expand limit of HCCI combustion at the high load. In dual fuel injection system port injection used to homogeneous charge preparation and direct injection was used to stratify the charge. Result indicated that in gasoline stratification extension of high load was restricted by the trade off between CO and  $\text{NO}_x$  in gasoline operation. When methanol stratification was used MRPR and the  $\text{NO}_x$  could be reduced.

Horng-Wen Wu et al. [25] evaluated the performance and emission characteristic of a partial HCCI. Gasoline and ethanol for port injection, diesel for direct injection were used. The experimental results compared with computational obtained solution. Results indicated that premixed ethanol had a more effective in emission control than premixed gasoline. The premixed ethanol had a more homogeneous temperature distribution and smaller high temperature zone than without premixed fuel and premixed gasoline do.

Srinivas Padala et al. [26] implemented dual-fuelling technology on a single-cylinder diesel engine. Ethanol was inducted along with the intake air by using a port-fuel injection system while diesel was injected conventionally into the combustion chamber. Main part of their study was to examine the effect of ethanol premixing and diesel injection timing on the engine performance and exhaust emission. The results indicated that the energy fraction up to 60% of diesel was replaced by ethanol, which achieved 10% efficiency gain compared to the conventional engine.

Xingcai Lu et al. [27] evaluated the combustion and emission parameters of the partial HCCI combustion using gasoline blends fuels G30 G40 and G50. The effects of the gasoline fraction in the blends, the premixing ratio, and the overall fuel supply rate on compound HCCI combustion were evaluated. They also investigated the effects of air boosting on G30



compound. At G30, minimum NO<sub>x</sub> and soot emission, HC and CO lower in compare to CIDI engine.

Can Cinar et al. [28] investigated the effects of premixing of diethyl ether on the combustion and exhaust emissions on diesel engine. The experiments were performed at 2200 rpm with the varying premixed ratio from 0 to 40 percent. Diethyl ether was injected externally by port injection using low pressure injector and controlled by programmable ECU. Positive results were obtained at low diethyl ether premixed ratio, but at 40% or more diethyl ether premixing leads to audible knocking. By increasing the DEE premixed ratio, the oxides of nitrogen and particulates emissions decreased up to 19.4% and 76.1% respectively, while the exhaust gas temperature reduced by about 23.8%. But, the adverse effect on HC and CO.

Jianye Su et al. [29] concentrated on the particulate matter from single cylinder CIDI diesel engine. The experiments were performed in a conventional engine with and without premixing of charges, using diesel, biodiesel and biodiesel-ethanol blends fuels. Research indicated that in conventional mode fuel accumulate in the cylinder. Accumulation of fuel would have reduced by use biodiesel and further reduce more by using biodiesel ethanol blend. With premixed LTC biodiesel particle size sift to smaller diameter. Biodiesel-E20 founds lowest accumulation in overall operation.

## CHAPTER 3

# EXPERIMENTATION

In partial premixed compression ignition engine ethanol is introduced in intake manifold, and some quantity of diesel is injected by conventional direct injection. By regulating the quantity of premixed ethanol and direct injected diesel, various premixed fractions obtained. The present study, investigates the consequence of premixed fractions on the combustion and emission parameters of diesel engine.

### 3.1 Fuel selection for the study

Ethanol is used as a premixed fuel because of its high latent heat of vaporization allowing a denser fuel–air charge, and excellent lean-burn properties. When ethanol is burnt, it forms more moles of exhaust gases, which gives higher pressure and more power in the expansion stroke relatively low boiling point and excellent ignition ability. The diesel chosen for direct injection, as a complementation under the condition of misfires or knocks to expand the engine operating range. The engine experiments were conducted over a load range with various premixed fraction, while the engine speed was fixed at 1500 rpm.

### 3.2 Fuel properties

The comparison of properties of ethanol used as premixed fuel and diesel used as a directly injected fuel in this study is given in Table3.1.

**Table3.1. Comparison of ethanol and diesel**

PROPERTY	ETHANOL	DIESEL
Chemical formula	C <sub>2</sub> H <sub>5</sub> OH	C <sub>12</sub> H <sub>26</sub>
Molecular weight (kg/kmol)	46	170
Oxygen percent (weight %)	34.8	Nil
Specific gravity	0.785	0.84-0.88
Boiling temperature at 1 atm (C)	78.3	190-280
Latent heat of vaporization (kJ/kg)	840	270
Stoichiometric air/fuel ratio	9.0	14.5
Lower heating value of fuel (MJ/kg)	26.9	42.5
Research octane number (RON)	107	-
Motor octane number (MON)	89	-
Density at 20 C (kg/m <sup>3</sup> )	790.7	820-900
Auto ignition temp	423	210
Cetane no	5-12	46-51

### 3.3 Description of the test engine

This section describes the complete experimental setup such as engine, coupled with alternator, emission test bench, data acquisition system, including piezoelectric pressure transducer and crank angle encoder. Some modifications have been done to achieve homogeneous combustion. The experiments were carried out on a single cylinder, four stroke, naturally aspirated CIDI engine and its main technical specifications are summarized in Table 3.2 and the schematic layout of the experimental arrangement is depicts in Fig. 3.3.

The cylinder pressure history, data acquisition and combustion analysis is done using a Lab view based program. All data related to pressure heat release mass fraction burnt power efficiency with respect to load and crank angle provided by this system. A fuel level indicator was used for measuring the diesel fuel consumption. An orifice-meter and a U-tube manometer were used to measure the intake air flow rate of the engine. An air box fixed into the intake manifold of the engine, maintains a constant air flow and eliminates cyclic fluctuations.

A K-type thermocouple was installed to measure the exhaust gas temperature. For the analysis of emission AVD DI gas 444 exhaust gas analyser connected to the exhaust pipe. It gives all emission quantity present in gas like NO<sub>2</sub>, CO, CO<sub>2</sub>, and HC. AVL 437 smoke meter is used to measure exhaust smoke.

**Table 3.2 Technical data of single cylinder engine**

Maker	Kirloskar
Cooling system	Air
Displacement (cm <sup>3</sup> )	662
Stroke (mm)	110
Bore (mm)	87.5
Compression ratio	17.5:1
Speed (rpm)	1500
Injection timing	23 degree bTDC
Injection pressure (bar)	200
Rated output	4.4 KW
Injection type	Pump-line-nozzle injection system
Nozzle type	Multi hole

### 3.4 Experimental procedure

Ethanol was injected in the intake manifold using port fuel injector. Along with intake air ethanol entered to the combustion chamber during the suction stroke. In the compression stroke, ethanol and air mixed homogeneously and got compressed. At the end of compression stroke diesel was injected conventionally. Ethanol is having low calorific value, as compared to diesel hence, diesel was used as compensation. In the present investigation, flow rates 0.21, 0.37, 0.51, 0.58 and 0.79 kg/hr of ethanol injected by port fuel injection. The combustion, performance and emission characteristics were evaluated for all loads with different premixed fraction.

### 3.5 Premixed fraction

The premixed fractions defined as the ratio of energy contribution of premixed fuel to whole energy contribution. That is

$$PF = \frac{\text{Primixed fuel energy}}{\text{Primixed fuel energy} + \text{Direct injected fuel energy}}$$

whereas,

Primixed fuel energy = (mass flow of premixed fuel)\* (calorific value of premixed fuel)

Direct injected fuel energy = (mass flow of direct injected fuel)\* (calorific value of direct injected fuel)

### 3.6. Engine modification

For achieving the PPCI combustion mode, it was required to operate the engine with some modification. In order to this, port fuel injection system and air pre-heater system were included in the intake manifold.

#### 3.6.1 Port fuel injection system

Fig. 3.1 shows the photograph of the fuel premixing system used in this study. This system consists of

1. Fuel injector
2. Injector control circuit
3. Program for electronic circuit
4. Fuel pump and fuel tank

A fuel injector is basically an ECU controlled solenoid valve, which open and closes to allow fuel pass through it. Fuel injector releases a controlled amount of pressurised fuel into the system. The injector is fed a constant supply of power and ECU provides a negative trigger to turn it on at the required time and for required interval.

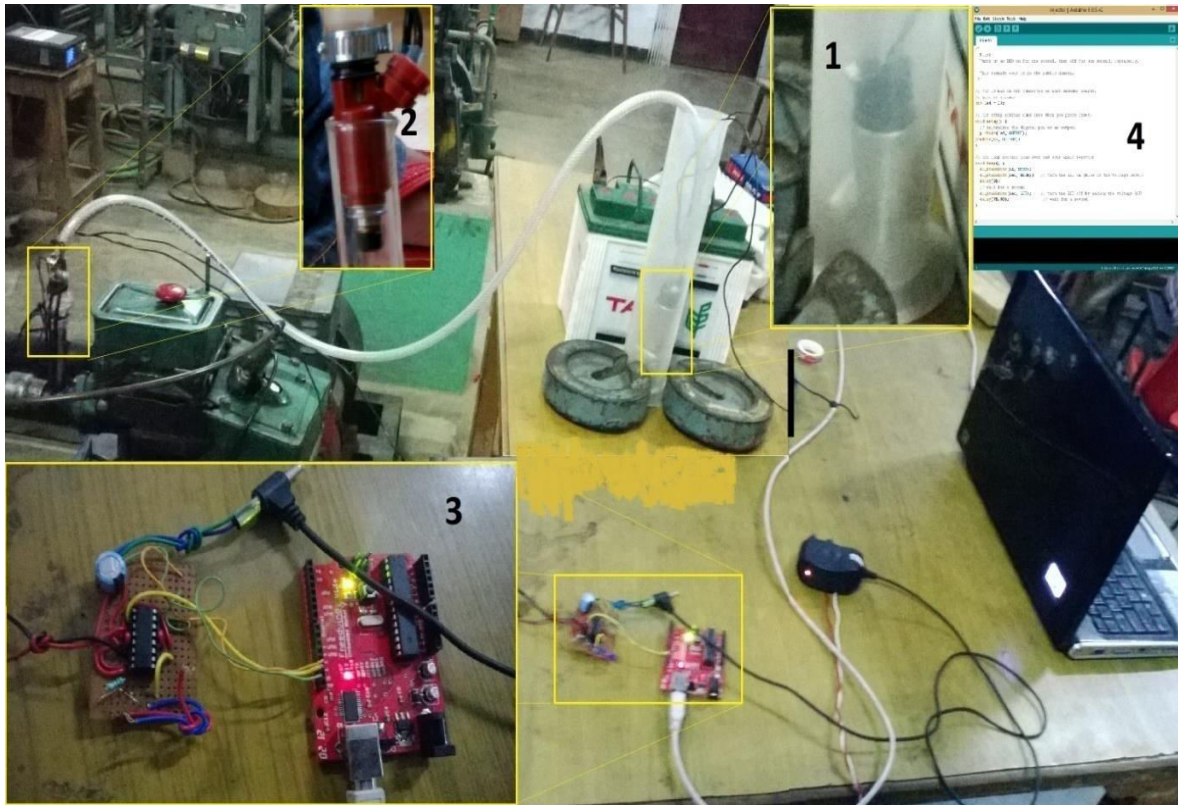

**Fig 3.1 Fuel premixing system** Fuel pump and fuel tank [1], Fuel injector [2], Injector control circuit [3], Program for electronic circuit [4]

A program is required for ECU to control the injection timing, which in turn triggers the fuel injector. At the place of ECU unit, a microcontroller was used here to control both the timing and quantity of fuel. The pulse width decides quantity of fuel injected.

In the present study, arduino software is in used to feed the program in microcontroller. Arduino is an open source software written in Java, uses to compile programs and to upload programs to the microcontroller.

An electrical fuel pump of 12 V DC supply is fitted inside fuel tank is used for boosting the premixed fuel from tank to injector. Property of this pump is to maintain a constant pressure inside fuel line if the pressure increases more than a limit pressure, secondary valve attached in pump automatic open and release the excess pressure.

### 3.6.2 Air pre-heating system

Figure 3.2 shows the photograph of the intake air pre-heater system used in study. The intake air pre-heater is controlled by temperature controller with feedback control, which keeps constant air temperature in intake manifold. The heater consist heating element, which is inserted into cylindrical box of GI sheet. The heating element wound over the ceramic structure. One inch thick glass wool insulation done outer layer of the heater, that provides both insulation as well as cushioning.

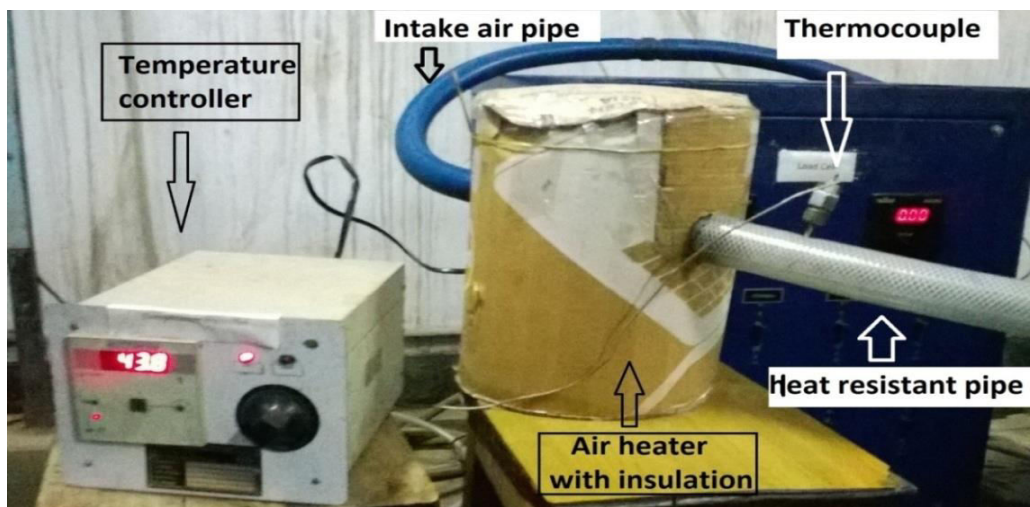

Fig 3.2 Intake air pre-heating system.

### 3.7 Schematic layout

The schematic layout of the experimental set up used in this study is shown in Fig. 3.3

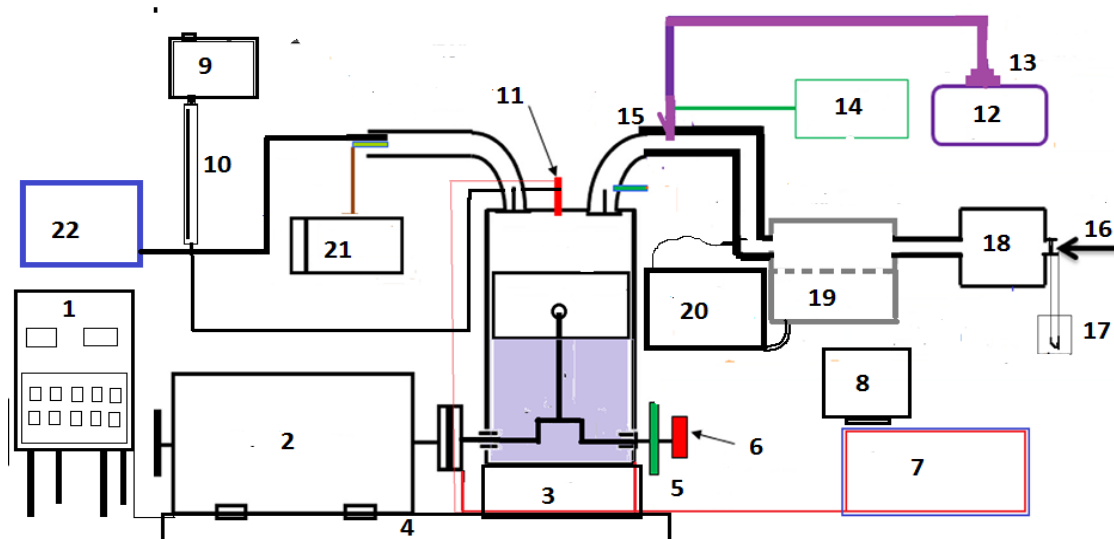

Fig 3.3 Schematic layout of experimental set up

1. Load cell	9. Fuel tank	17. Orifice meter
2. Alternator	10. barrette	18. Air box
3. Engine	11. Injector	19. Heater
4. Engine bed	12. Secondary fuel tank	20. Temperature controller
5. TDC sensor	13. Fuel pump	21. Exhaust gas analyser
6. Encoder	14. ECU	22. Smoke meter
7. Data acquisition sys.	15. Port injector	
8. Computer	16. Intake air	

**Table 3.3 Error analysis of instruments**

S. no	Instrument	Range	Accuracy	Uncertainty
1	Load indicator	250–5000W	±10W	±0.2
2	Temperature indicator	0-900	±1 °C	±0.15
3	Burette	1–30 cc	±0.2 cc	±1
4	Speed sensor	0–10,000 rpm	±10 rpm	±0.1
5	Exhaust gas analyser	NO-0–5000 ppm	±12 ppm	±0.2
		HC-0–20,000 ppm	±12 ppm	±0.2
		CO-0–10%	0.06%	±0.2
6	Pressure transducer	0–110 bar	±0.1 bar	±0.05
7	Crank angle encoder	0-720	±1°	±.2

### 3.8 Uncertainty Analysis

The total percentage of uncertainty of this experiment = square root of [(uncertainty of TFC)<sup>2</sup> + (uncertainty of BP)<sup>2</sup> + (uncertainty of BSFC)<sup>2</sup> + (uncertainty of Brake thermal efficiency)<sup>2</sup> + (uncertainty of CO)<sup>2</sup> + (uncertainty of CO<sub>2</sub>)<sup>2</sup> + (uncertainty of NO)<sup>2</sup> + (uncertainty of Smoke meter)<sup>2</sup> + (uncertainty of UBHC)<sup>2</sup> + (uncertainty of Pressure pick up)<sup>2</sup> + (uncertainty of crank angle encoder)<sup>2</sup> + (uncertainty of port injector)<sup>2</sup>

$$= \sqrt{\{(1.5)^2 + (0.2)^2 + (1)^2 + (1)^2 + (0.2)^2 + (0.15)^2 + (0.2)^2 + (0.2)^2 + (0.15)^2 + (1)^2 + (0.5)^2\}} = \pm 2.38$$





**Fig. 3.4** Pictorial view of experimental set up

# CHAPTER 4

# RESULTS & DISCUSSION

**Module I:** Preliminary investigation on the combustion, performance and emission parameters for a PPCI combustion mode with the naturally aspirated air without charge heating.

## 4.1 Combustion characteristics

Combustion characteristics with respect to a premixed fraction, is varying for low, medium and full load operations. Full load operation has been carried out at 4.4 kW, medium load at 3.3 kW and low load operations done at 2.2 kW and 1.1 kW loads.

### 4.1.1 Pressure crank angle diagram at full load operation

Fig 4.1 depicts the variation of cylinder pressure with crank angle at full load for different premixed fractions. The start of injection for diesel was set 23°CA bTDC, while ethanol was inducted with the air. The maximum cylinder pressure at 4.4 kW load for diesel operation is found to be 70 bar.

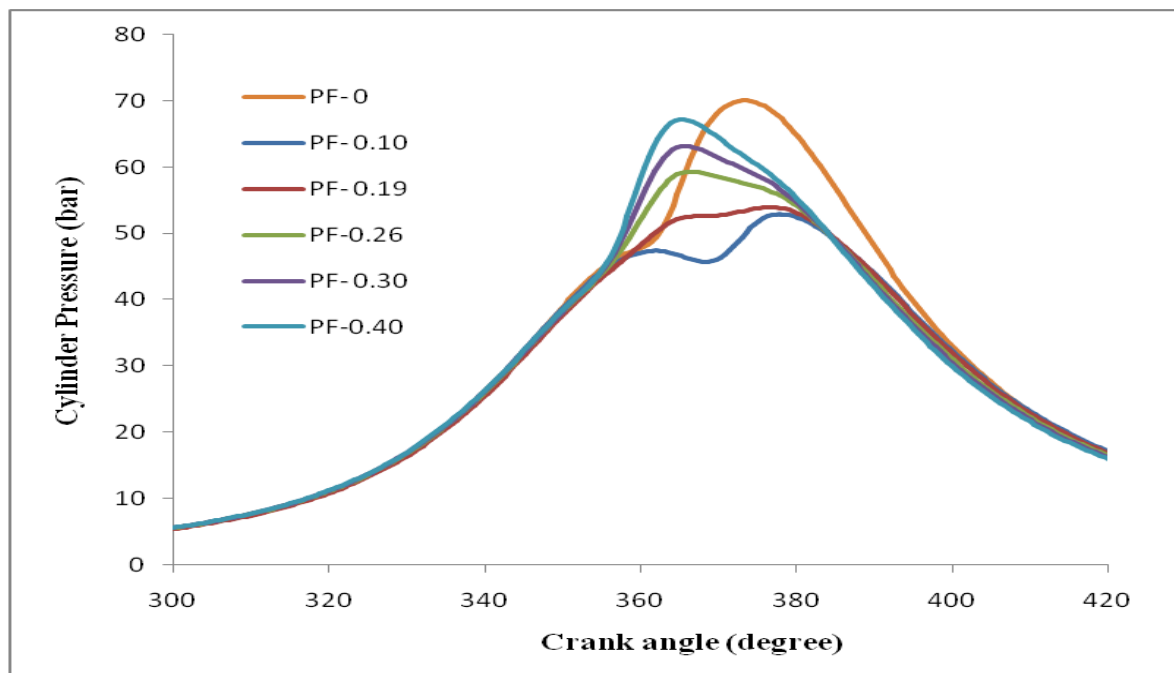

**Fig 4.1 Variation of cylinder pressure with respect to crank angle**

By increasing the ethanol premixed fraction leads to a decrease in cylinder pressure near TDC. This is due to the vaporisation cooling of ethanol [26]. Ethanol has a high latent heat of vaporization and it requires a high amount of heat to absorb from the cylinder to change phase results in substantial cooling of the fresh charge called vaporisation cooling of ethanol.

For full load, drop in the cylinder pressure shows only for lower ethanol fraction. At higher ethanol fraction, advance pressure rise is observed. This is because of self ignition of ethanol at the end of compression stroke. For the premixed fractions of 0.10, 0.19, 0.26, 0.30, 0.40 the cylinder pressures are 52.87, 53.93, 59.36, 63.51 and 67.18 bar respectively. Further increase in the premixed fraction leads to misfire at 4.4 kW load.

#### 4.1.2 Heat release rate with crank angle diagram at full load operation

The variation of heat release rate with crank angle for different premixed fractions at full load is depicted in Fig. 4.2 The heat release from the combustion follows first law of thermodynamics for a closed system using the equation [1]

$$\frac{dQ}{d\theta} = \frac{\gamma}{\gamma-1} P \frac{dV}{d\theta} + \frac{1}{\gamma-1} V \frac{dP}{d\theta} \quad \dots\dots\dots [1]$$

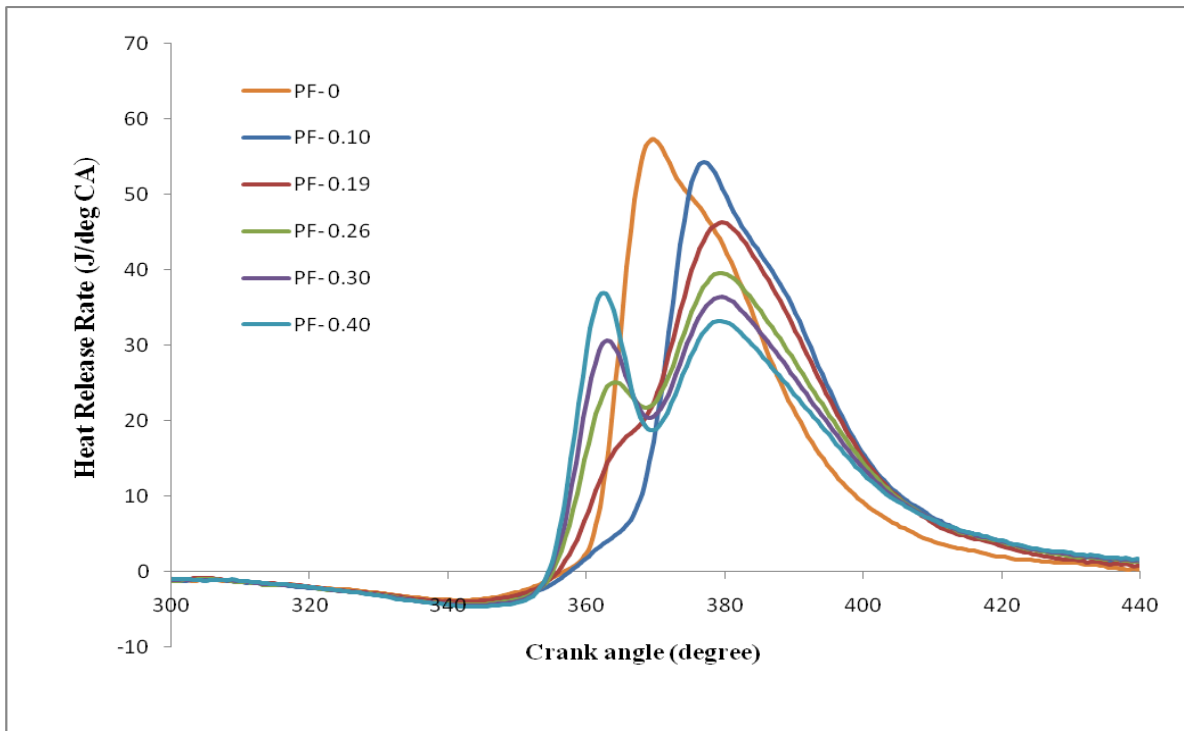

**Fig. 4.2 Variation of heat release rate with crank angle at full load**

The heat release rate shows the intensity of rapid combustion. Maximum heat release rate for diesel operation at full load is 57.3 J/°CA. Auto ignition of ethanol takes place before diesel ignition at full load. Combustion is divided into two phases, by increasing the premixed fraction first phase HRR increases and second phase decreases. It is due to the increase of fuel burnt in the premixed mode and reduction of fuel burnt in diesel mode. At premixed

fraction 0.40, the maximum HRR is 36.89 J/deg in the first phase, while in second phase occur is 33.23 J/deg.

#### 4.1.3 Pressure crank angle diagram at medium load

Fig 4.3 depicts the variation of pressure with a crank angle at medium load for different premixed fractions. The combustion occurs in a single stage. A clear trend is observed from the figure that with increasing premixed fraction, start of combustion is delayed and peak pressure decreases near TDC. The maximum cylinder pressure at the medium load for the diesel operation is 68 bar and the maximum cylinder pressure for all the premixed ratios is almost same with the range of 55-56 bar.

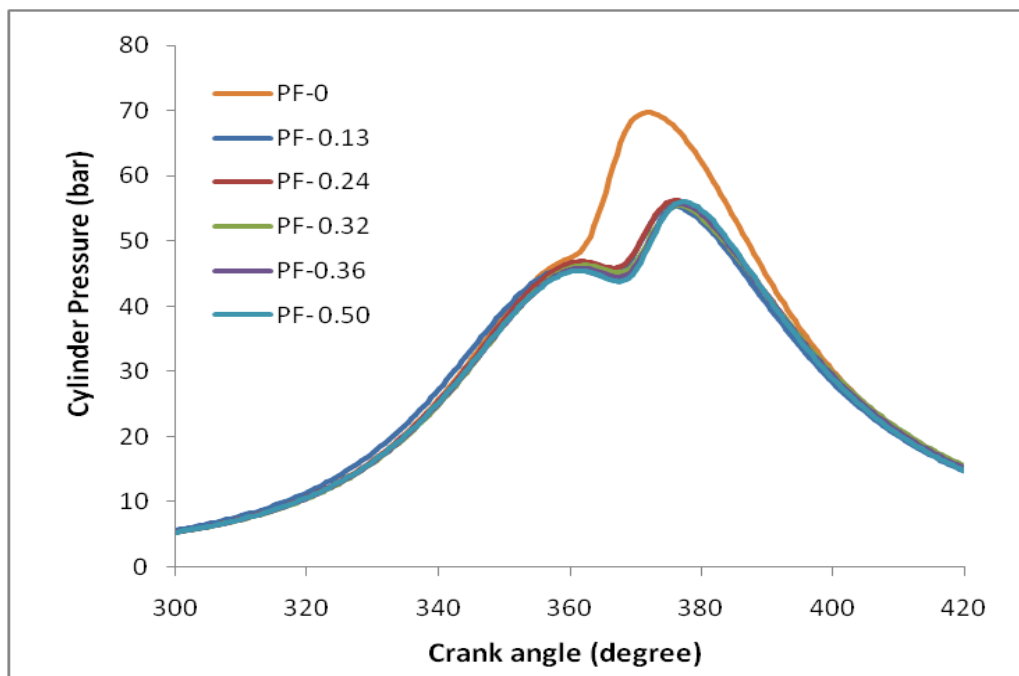
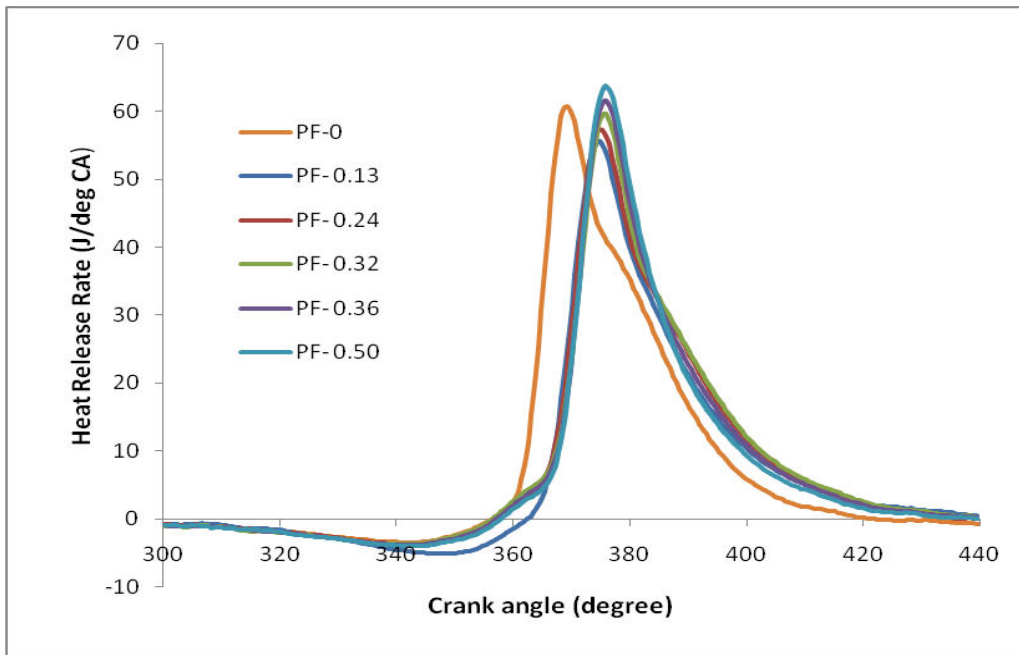

Fig 4.3 Variation of cylinder pressure with crank angle at medium load

#### 4.1.4 Heat release rate with crank angle diagram at medium load

The auto ignition temperature of ethanol is high and it has not able to reach at self ignition level for medium and low loads. Because of this, ignition is started by diesel fuel. In the premixed mode, diesel burns after diffusion in the mixture of air and ethanol, not only pure air. Moreover, ignition delay increases because of lower pressure and temperature in cylinder due to vaporization cooling of ethanol. Fig. 4.4 shows clearly, as the premixed fraction increases the maximum heat release rate increases. This is due to premixing ethanol and

longer ignition delay gets sufficient time to diesel for homogeneous mixing. A maximum HRR found at premixed fraction 0.50 and its value is 63.71 J/°CA.



**Fig. 4.4** Variation of heat release rate with crank angle at medium load

#### 4.1.5 Pressure crank angle diagram at low load

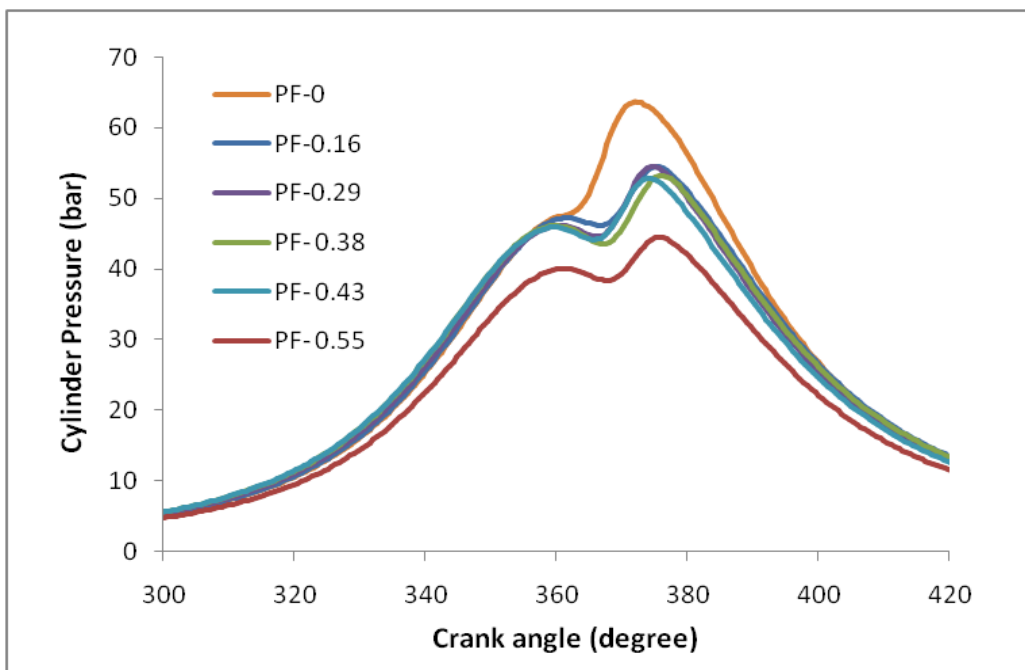

**Fig 4.5.** Variation of cylinder pressure with crank angle at low load



Fig 4.5 shows the variation of cylinder pressure with crank angle at low load operation. The pressure curve is found to be similar trend for all the fractions except for the high premixed fractions. The maximum pressure for diesel operation at 2.2 kW load is 63 bar. At higher premixed fraction, the cylinder peak pressure decreases. At 0.55 premixed fraction, the maximum pressure decreased to be about 45 bar. It would be due to partial burning and further increased in premixed ratio misfire occur [14].

#### 4.1.6 Heat release rate with crank angle diagram at low load

For low load operation, by increasing the premixed fraction heat release rate initially increases then decreases. The overall air fuel ratio leaner at low loads, because of this ethanol quenching occurs at a higher premixed fraction. The maximum heat release rate for diesel operation shown is  $56.6 \text{ J/}^\circ\text{CA}$  and for the premixed fraction of 0.16, 0.29, 0.38, 0.43, 0.55 is about 53.3, 53.4, 55.3, 48.4 and  $42 \text{ J/}^\circ\text{CA}$  respectively.

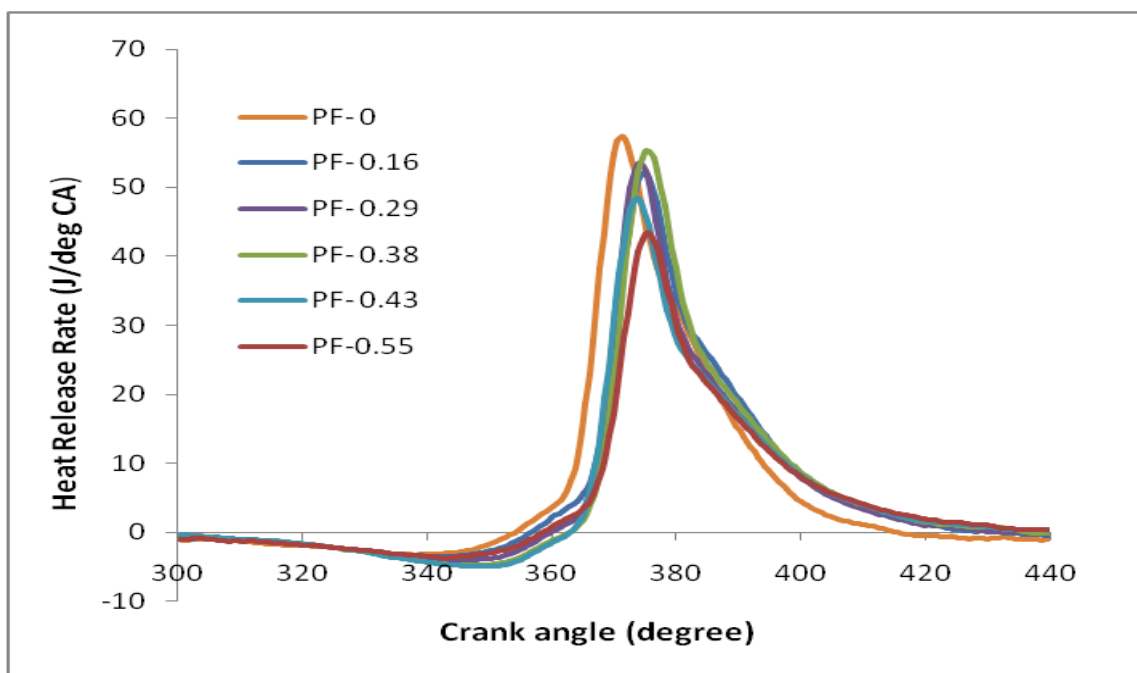
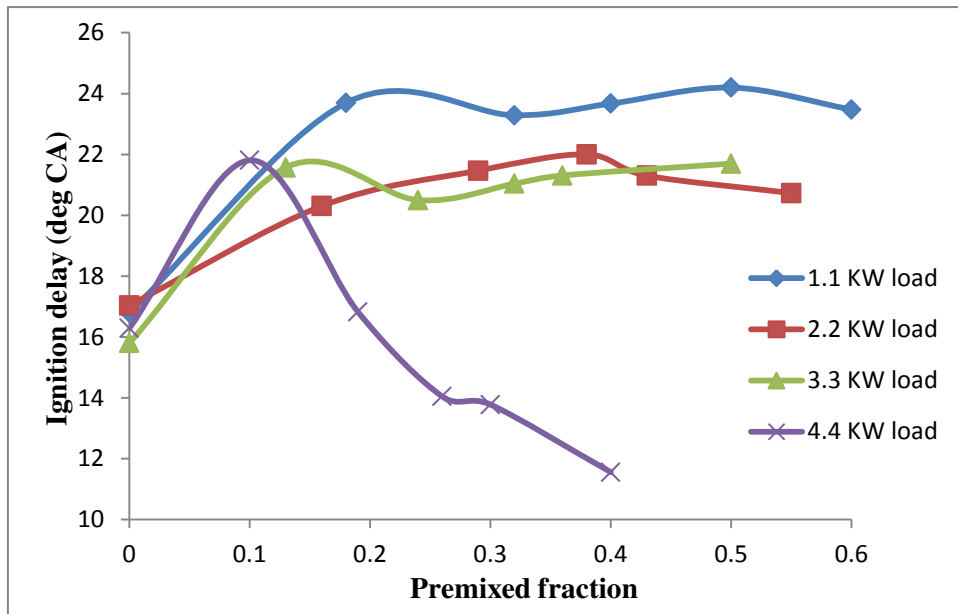

**Fig. 4.6 Variation of heat release rate with crank angle at low load**

#### 4.1.7 Ignition delay

Ignition delay is an important factor to understand the combustion process. It is the time difference between start of injection and start of ignition measured in degree crank angle. Fig 4.7 shows the variation of Ignition delay with the premixed fraction for all loads. The delay increases with the increasing amount of ethanol inducted with the air. It is due to the higher

latent heat of ethanol. The delay increases from 16 °CA to 24 °CA for lower loads. It may have two reasons first vaporization cooling and leaner air fuel ratio. For medium load ignition delay reduces up to 21.7 °CA. At full load ignition delay drop from 21.8 °CA to 11.6 °CA for the premixed fraction 0.1 to 0.4 respectively. This may be due to advance combustion of ethanol. Actually, this ignition delay is only for diesel and the early combustion of ethanol provides heat to reduce the ignition delay for diesel fuel.



**Fig 4.7. Variation of ignition delay with premixed fraction**

#### 4.1.8 Peak cylinder pressure

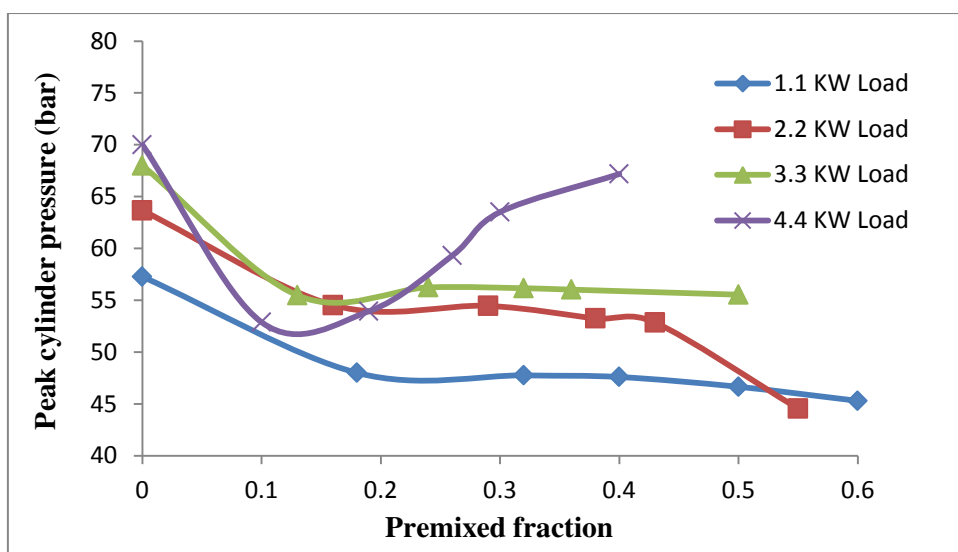

**Fig 4.8. Variation of peak cylinder pressure with premixed fraction**



The graph plotted between the peak cylinder pressure and the premixed fraction for different loads are shown in Fig 4.8. The peak cylinder pressure depends on fuel quality, ignition delay and fuel air mixture. Early ignition provides higher peak value. The peak pressure decreases by increasing premixed fraction due to longer ignition delay and vaporization cooling of ethanol. There is a different curves obtained between full load to lower loads because of advance stage burning of ethanol at higher loads. From premixed fraction 0.1 to 0.4 , peak cylinder pressure increases 53 to 67 bar. At low loads, higher premixed fraction showing degrade of peak pressure. It may be due to insufficient combustion. At medium load, it shows almost constant peak pressure 54 bar up to 0.5 premixed fractions

#### 4.1.9 Maximum heat release rate

The maximum heat release rate mainly depends upon ignition delay and fuel air mixing. Ethanol has a high auto ignition temperature and high latent heat of vaporization. The latent heat of ethanol makes longer ignition delay for diesel fuel. It provides sufficient time to mixing charge as a result rapid combustion and high heat release rate.

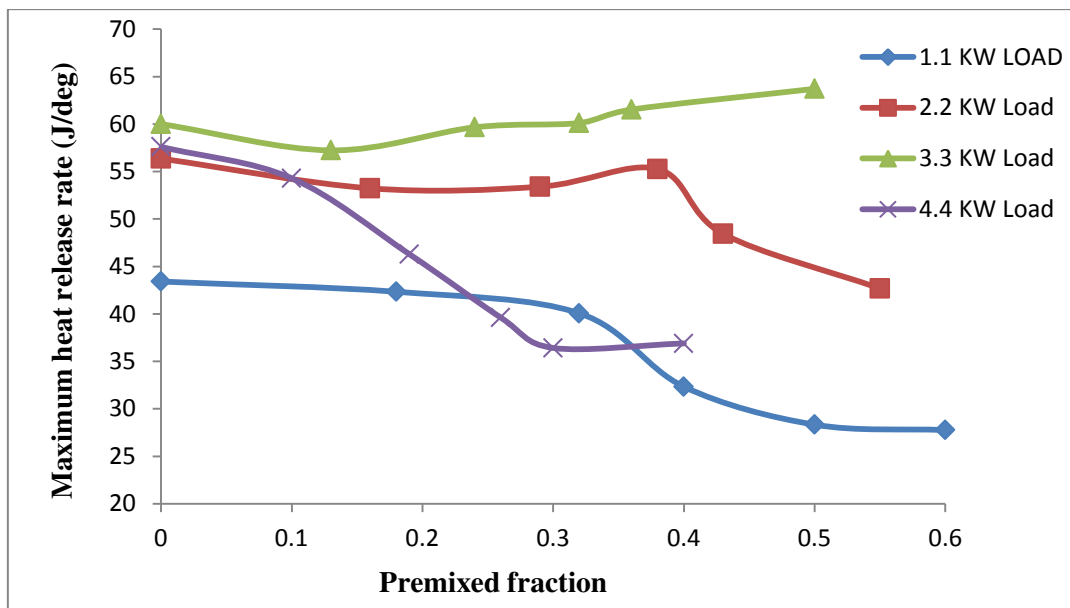

**Fig 4.9 Variation of maximum heat release rate with premixed fraction**

Fig 4.9 shows the variation of maximum heat release with respect to premixed fraction for all loads. It can be observed from figure, three trends of maximum heat release rate variation with the premixed fractions. For full load, the maximum heat release rate decreases with respect to premixed fraction increases. This is due to two stage combustion. The maximum HRR reduces from 57.6 J/°CA to 36.9 J/°CA with the premixed fractions 0 to 0.4. For 3.3

kW load, maximum heat release rate increases with respect to premixed fraction increases. The maximum HRR shows increment from 57.3 J/°CA to 63.7 J/°CA with the premixed fractions from 0.14 to 0.5. For low loads operation, initially small increment and then reduce to very low value. This is due to ethanol quenching in low temperature combustion chamber.

#### 4.1.10 Combustion duration

Generally, combustion duration increases with increasing load because of more fuel has to burn. Fig 4.10 depicts the variation of combustion duration with premixed ratio for all loads. Increasing loads 1.1, 2.2, 3.3, 4.4 kW combustion duration increases 25.38, 30.50, 34.80 and 38.4° CA respectively for diesel operation. Moreover, combustion duration increases, further with increasing premixed fraction. For low load operation after premixed fraction 0.4, shows longer combustion duration. For medium load, 26% increment in combustion duration up to premixed fraction 0.5. For full load combustion duration increases more than 50% up to premixed fraction 0.4. This is because of two stage combustion.

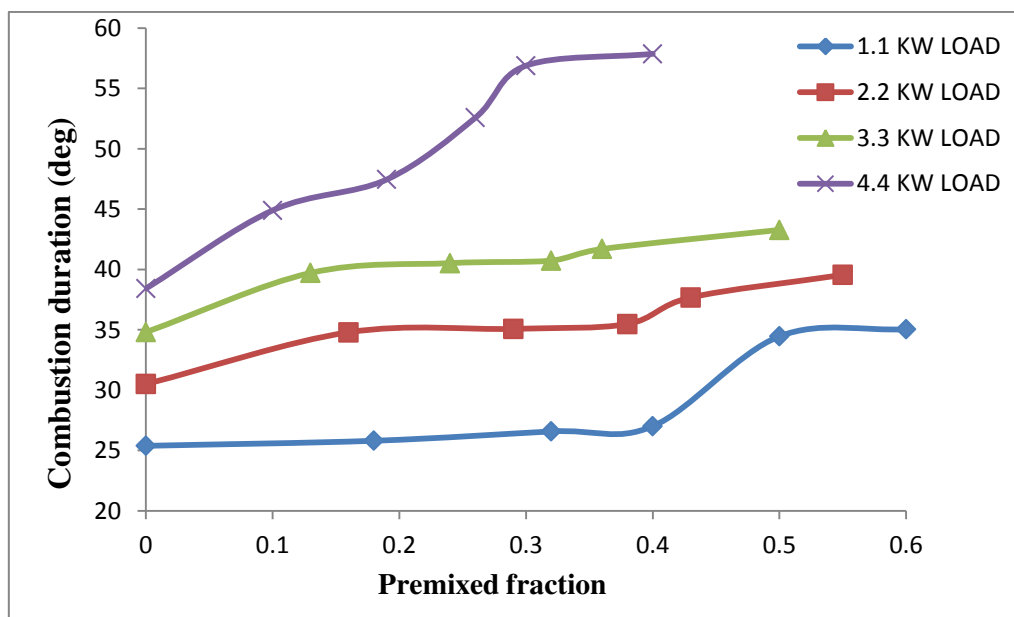

Fig 4.10 Variation of combustion duration with premixed fraction

## 4.2 Performance characteristics

### 4.2.1 Brake specific energy consumption

Brake specific energy consumption is an important parameter to observe the performance of engine. It is the product of brake specific fuel consumption and calorific value of the fuel. Fig 4.11 shows the variation of BSFC with respect of premixed fraction. Generally BSFC

decreases with the increase in the load. For diesel operation, the value of BSFC is 22.0, 14.3, 12.8, 12.04 MJ/kWh at 1.1, 2.2, 3.3, and 4.4 kW load respectively. Increasing premixed fraction, value of BSFC almost same for higher load, but for lower load it consume more energy. The BSFC increases 35% with premixed fraction 0 to 0.6 at 1.1 kW load and increases 15% from premixed fraction 0 to 0.55 at 2.2 kW load. This is due to incomplete combustion and less contribution of ethanol burned energy.

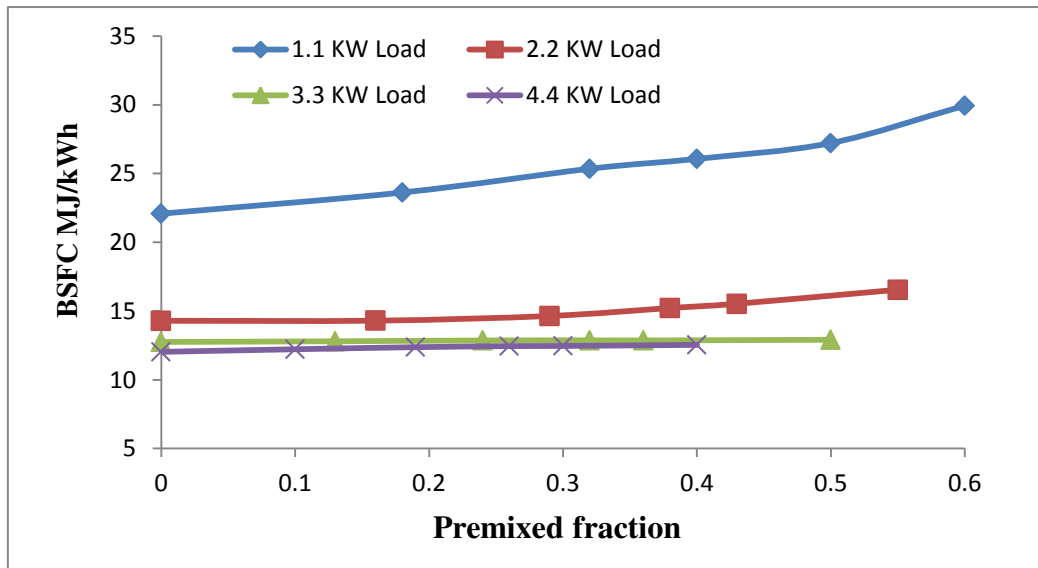

**Fig 4.11 Variation of BSFC with premixed fraction**

#### 4.2.2 Exhaust gas temperature

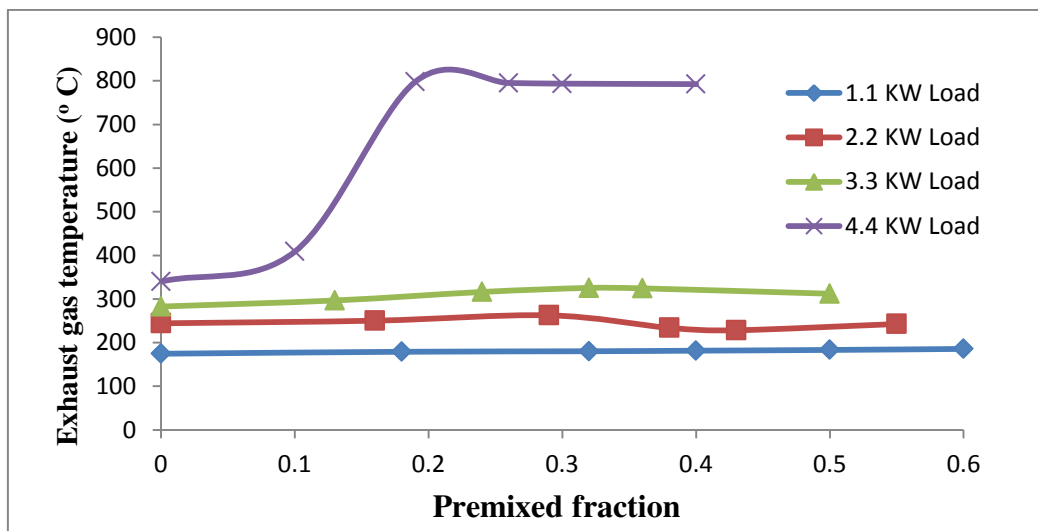
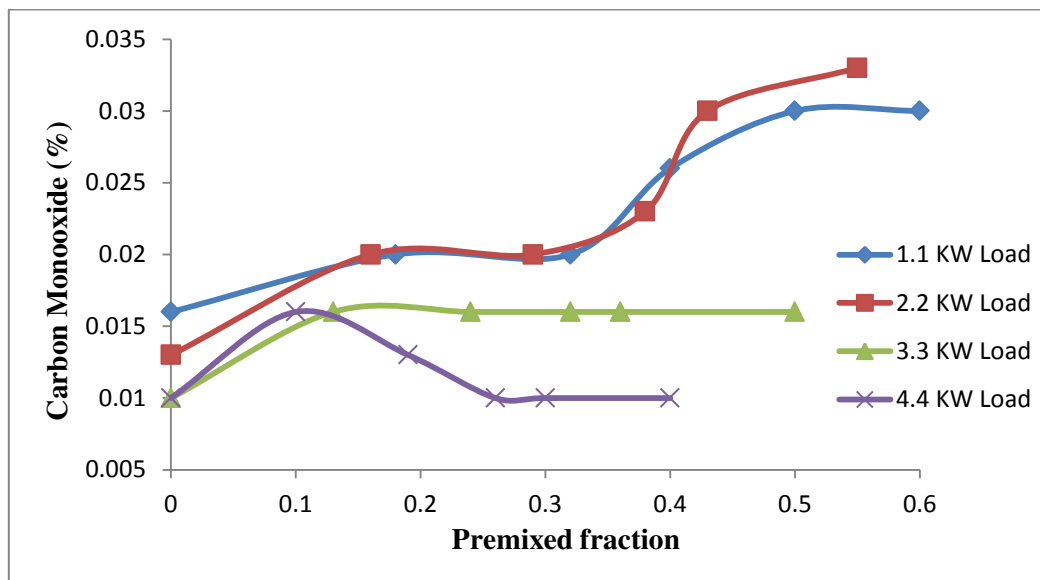

**Fig 4.12 Variation of exhaust gas temperature with premixed fraction**

The exhaust gas temperature mainly depends upon in cylinder temperature and expansion process. Fig 4.12 shows the variation of exhaust gas temperature with respect to the premixed fraction. The exhaust gas temperature increases with increase load. Figure shows high increment 340 °C to 792 °C in exhaust gas temperature at full load. It may be to two stage combustion or heat release in expansion process, but it proves high temperature inside the cylinder because of this premixed ethanol auto ignited. For low loads, only marginal increment in the exhaust gas temperature occurs. For medium load, maximum 14 % increment in exhaust gas temperature occurs.

### 4.3 Emission characteristics

#### 4.3.1 Carbon monoxide (CO) emission



**Fig 4.13. Variation of carbon monoxide with premixed fraction**

Fig 4.13 shows the variation carbon mono oxide with premixed fraction for all loads. For diesel operation, the CO emission decreases 0.016% to 0.01% with increasing load 1.1 kW to 4.4 kW. Reasons for the higher CO emission are to incomplete combustion, heterogeneity of air fuel mixture and temperature rise inside the cylinder. Homogeneity of charges increases with premixed fraction but for low loads combustion inefficiency, leads to increase in the CO emission. At full load, the homogeneous mixture and two stage heat release leads to lower CO emission. At middle load, figure shows almost constant value for all premixed fraction. For all load except full load premixed fraction, the CO emission is high in comparison with diesel operation.

### 4.3.2 Carbon dioxide (CO<sub>2</sub>) emission

Variation of the carbon dioxide with premixed fraction for all loads is shown in Fig 4.14. Mainly two factors which are more responsible for the CO<sub>2</sub> which are higher temperature in combustion chamber and availability of air to get CO oxidised and form CO<sub>2</sub>. The CO<sub>2</sub> emissions have shown almost reciprocal to the CO emissions. Pure diesel operation at premixed fraction 0, CO<sub>2</sub> increases 0.53, 0.93, 1.3, 1.43 percent with increasing loads 1.1, 2.2, 3.3 and 4.4 kW respectively. By inducting ethanol premixed fraction, the CO<sub>2</sub> values are low at higher load. This is due to the effect of either low temperature combustion or complete combustion. CO<sub>2</sub> value for the premixed operation reduces almost 50% in comparison with the diesel operation at full load. At 3.3 kW and 4.4 kW, value of CO<sub>2</sub> showed 0.55 to 0.70 for premixed fraction 0.1 to 0.4. It is also low at 1.1 kW load but this is only due to the effect of inefficient combustion.

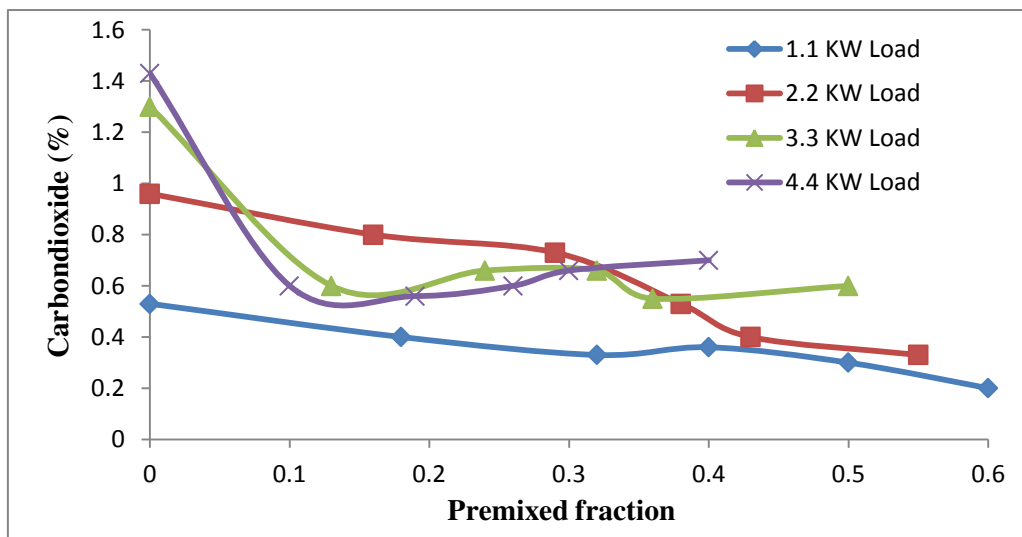
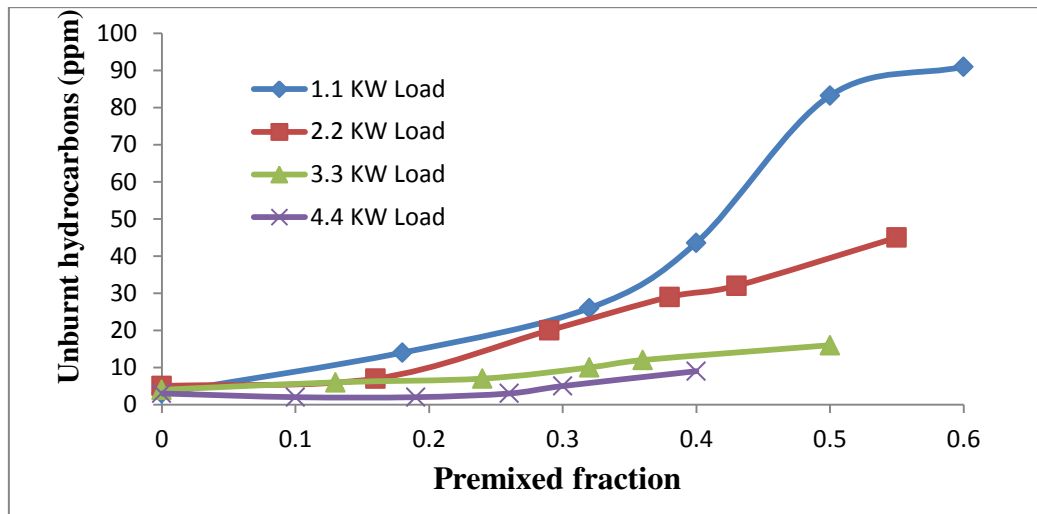

Fig 4.14 Variation of carbon dioxide with premixed fraction

### 4.3.3 Unburned Hydrocarbon (HC) emission

The unburned hydrocarbon (HC) emission is the result of oil film absorption, crevice volume misfiring condition or incomplete combustion of hydrocarbon fuels. The HC emission is one of the main disadvantages of premixed charges. The HC emission is directly proportional to ethanol premixed fraction. Fig 4.15 shows the variation of HC emission with premixed fraction for all loads. At higher premixed fraction high increment occurs for low load is the result of ethanol quenching due to low combustion temperature in the cylinder. Especially after increasing premixed fraction up to 0.04, value of HC emission increasing more than 8

times for 1.1 kW load. The HC emission is very low at full load operation. The maximum value of HC emission at full load is 9 ppm only but for low load it goes to 90 ppm.



**Fig 4.15. Variation of unburnt hydrocarbon with premixed fraction**

#### 4.3.4 Nitric oxide (NO) emission

The premixed ethanol results in a significant decrease in the NO concentration for all load operation. The NO<sub>x</sub> emission increases due to the availability of oxygen and higher combustion temperature. The NO emission reduction is the prime objective of all low temperature combustion mode operation, either HCCI or PPCI combined mode.

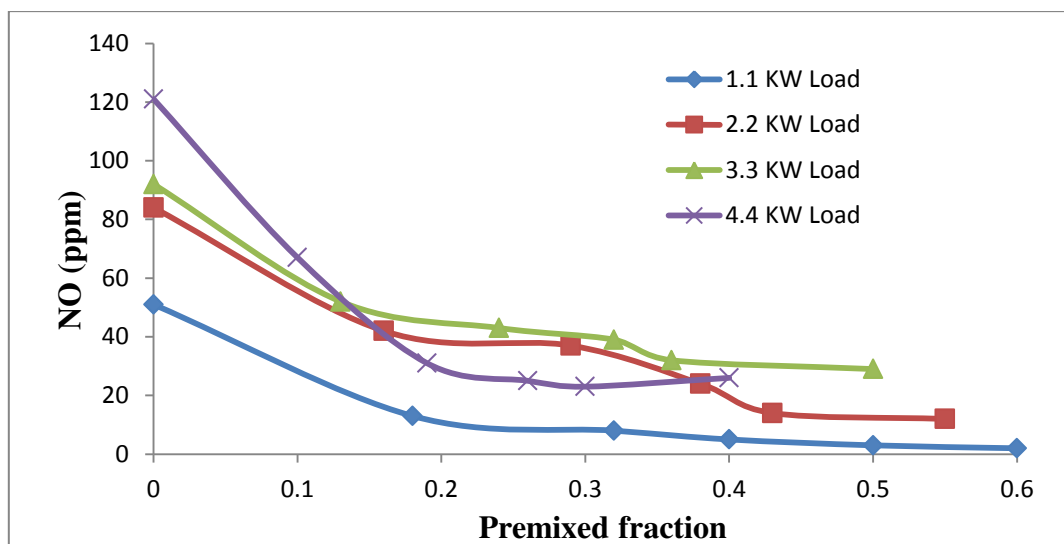
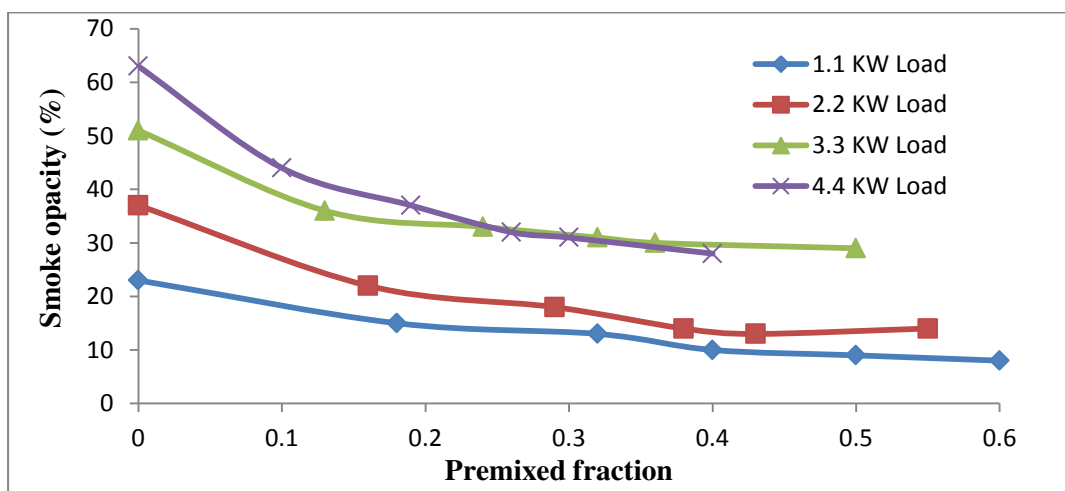

**Fig 4.16. Variation of nitric oxide with premixed fraction**

. Fig 4.16 shows the variation of NO with respect to premixed fraction for all loads. It is seen from figure, the NO emission reduces by increasing premixed fraction due to increasing premixed fraction leads to low temperature combustion. At higher premixed fraction, it shows lesser value at full load which decreases from 121 ppm to 26 ppm with premixed fraction increases up to 0.04. At low load, the NO emission decreases at 2 ppm up to premixed fraction 0.06. The drastically reduction may be due to very low temperature inside the cylinder results in inefficient combustion of ethanol. For the medium load also, it gives moderate result, value of NO emission reduces from 92 ppm to 28 ppm.

### 4.3.5 Smoke opacity

Fig. 4.17 shows the variation of smoke opacity with the premixed fraction for all loads. The reasons for the higher smoke opacity in the exhaust, is accumulation of fuel, local equivalent ratio and poor mixing of charges. The premixed ethanol increases the homogeneity of charges inside the cylinder and longer ignition delay improves duration to mixing of diesel with air. Increasing the premixed fraction of ethanol leads to reduction in the smoke opacity percentage in the exhaust due to the increase of fuel burnt in premixed mode and reduction of fuel burnt in diesel mode. From figure, is observed that increasing premixed fraction smoke density reduces significantly. In diesel operation, the smoke density varies from 20% to 63% from low to high load. At higher premixed fraction, this limit reduces from 8% to 29% from low load to high load. At full load, the smoke density for premixed fraction 0.4 is found to be 28% which is much lesser than diesel at full load.



**Fig 4.17 Variation of smoke opacity with premixed fraction**

**Module II:** The combustion, performance and emission parameter for PPCI combustion mode with the naturally aspirated air, heated at 110 degree Celsius.

#### 4.4 Combustion characteristics

From the first module results, it is clear that the vaporization cooling of ethanol is a big problem at low loads operation because ethanol required high amount of heat from combustion chamber to vaporize. At low loads, if the sufficient heat is not available inside the cylinder, ethanol diffuses in cylinder without contributing energy. Due to this, high BSFC consumption and HC emission at higher premixed fraction. In order to improve the operating limit of premixed mode at low loads, investigated the effect of charge heating on 1.1 kW, 2.2 kW and 3.3 kW loads.

##### 4.4.1 Pressure crank angle diagram

Figure 4.18 shows the variation of cylinder pressure with respect to crank angle at 2.2 kW load with charge heating. In the first module, results showed that pressure drop near TDC with increasing premixed fraction due to vaporisation cooling of ethanol. After charge heating, pressure drop near the TDC reduces due to less affect of the vaporization cooling on combustion.

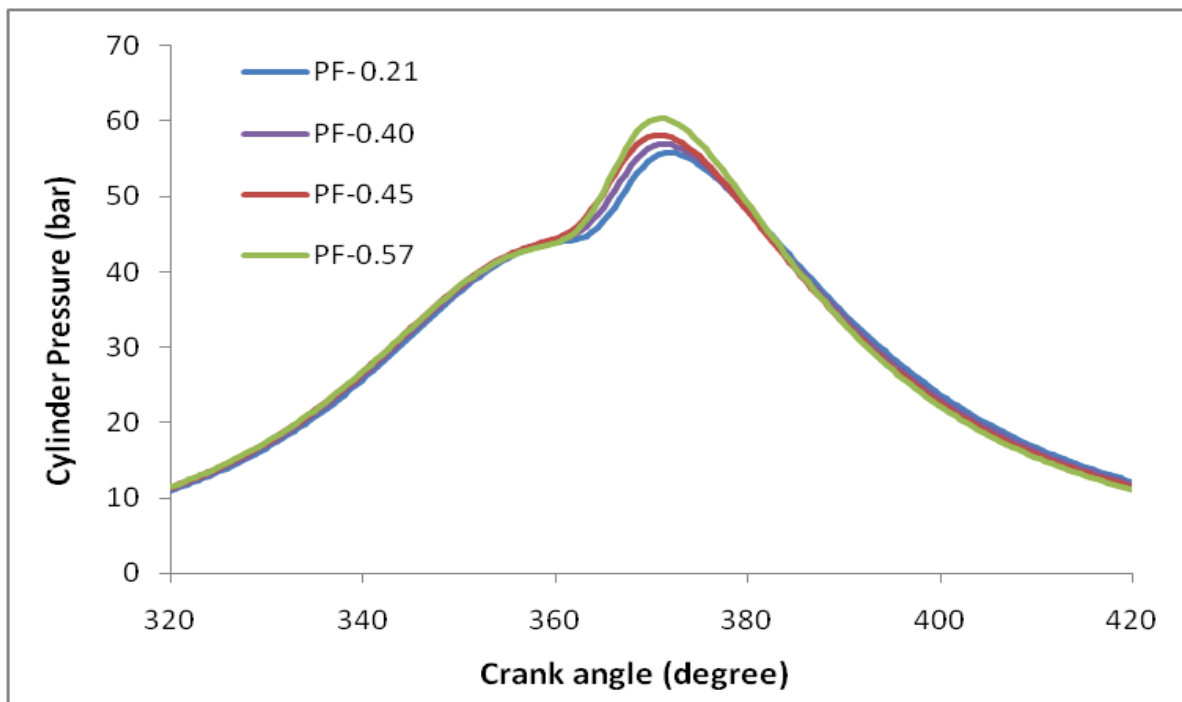

**Fig 4.18** Variation of cylinder pressure with crank angle at 2.2 kW load



Peak pressure increases with increasing premixed fraction up to 0.57. The maximum cylinder pressure is 60.3 bar at premixed fraction 0.57. Moreover, maximum pressure at premixed fraction 0.31, 0.40, 0.45 and 0.57 occurs at 371.9°, 371°, 370.8° and 370.9° CA respectively. Increasing the premixed fraction, peak pressure increases and shifts towards the TDC.

#### 4.4.2 Heat release rate with crank angle diagram at low load operation

Fig 4.19 depicts the variation of heat release rate with respect to crank angle. High heat release rate shows intensity of rapid combustion, by increasing the premixed fraction leads to rapid combustion and shorter combustion duration. In comparison with the first module, heat release rate enhanced by using charge heating with respective premixed fraction at 2.2 kW loads. The maximum heat release rate increases up to 47.4 J/°CA at premixed fraction 0.57.

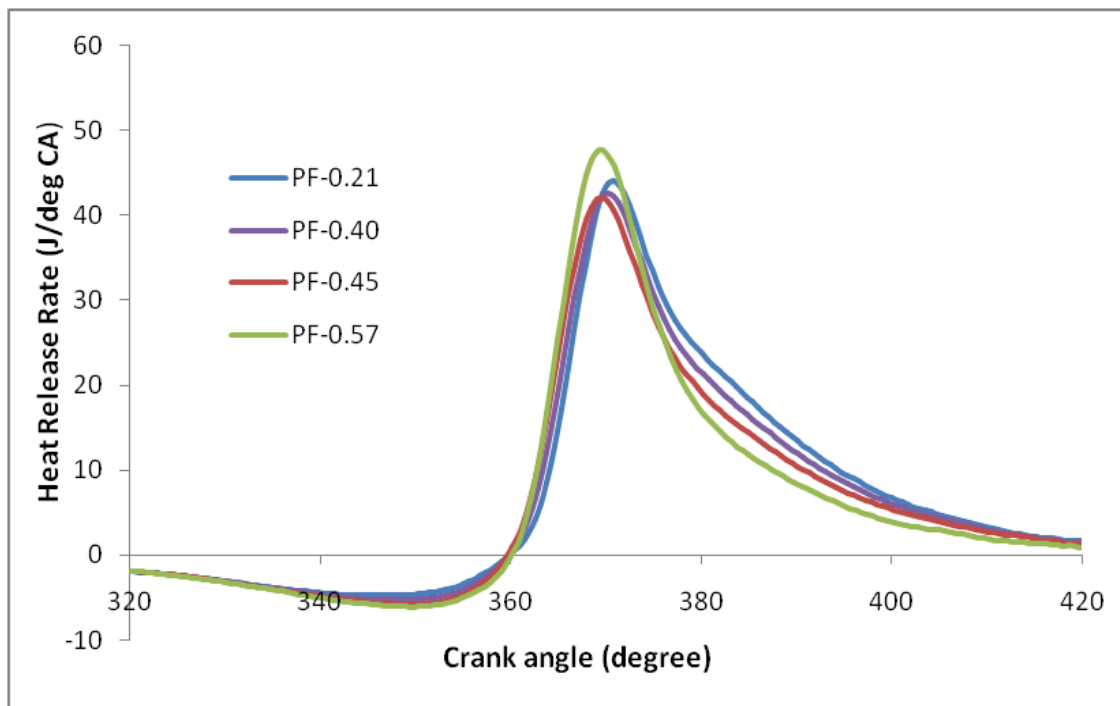
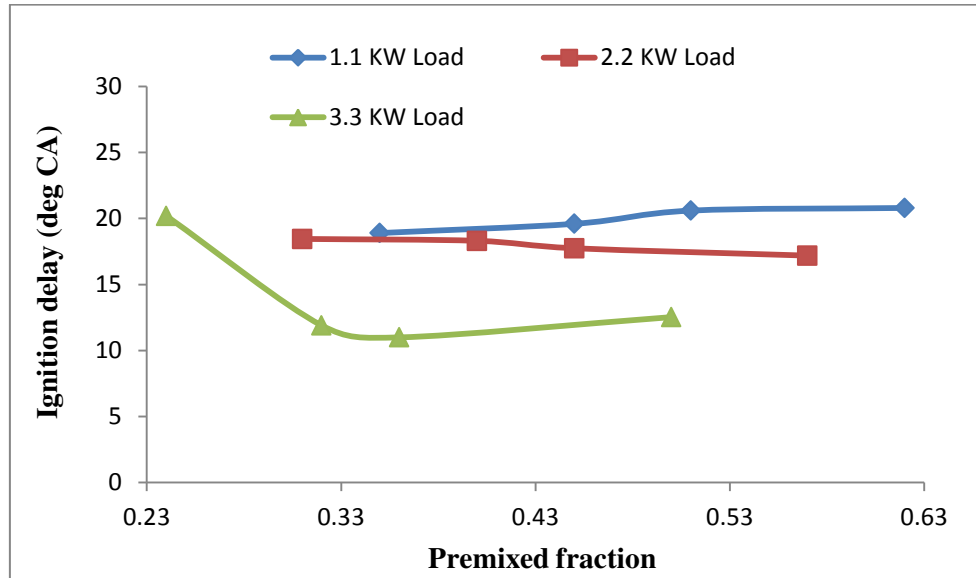

Fig. 4.19 Variation of heat release rate with crank angle at 2.2 kW load

#### 4.4.3 Ignition delay

Fig 4.20 depicts the variation of ignition delay with respect to the premixed fraction. Ignition delay decreases with increase in the premixed fraction in this study. Charge heating provides, a sufficient heat to vaporize ethanol, because of this increasing ethanol premixed fraction, leads to shorter ignition delay. Ignition delay reduces for the all load operation, after charge heating. Large reduction in ignition delay is due to two stage combustion at 3.3 kW. For 3.3 kW load ignition delay decreases up to 11.3° CA at premixed fraction 0.24. For 2.2kW and

1.1kW loads the delay not varies more with increasing premixed fraction but its values is 13% to 18% less than the without charge heating values. Ignition delay are approximately 18°CA at 2.2 kW and for 1.1kW it is 20 °CA at the premixed fraction 0.62 with charge heating.



**Fig. 4.20 Variation of ignition delay with premixed fraction**

#### 4.4.4 Peak cylinder pressure

The peak cylinder pressure represents the combustion condition inside the cylinder. It is depends upon the ignition delay and fuel quality. Fig. 4.21 depicts the variation of peak cylinder pressure with respect to the premixed fraction in charge heating condition.

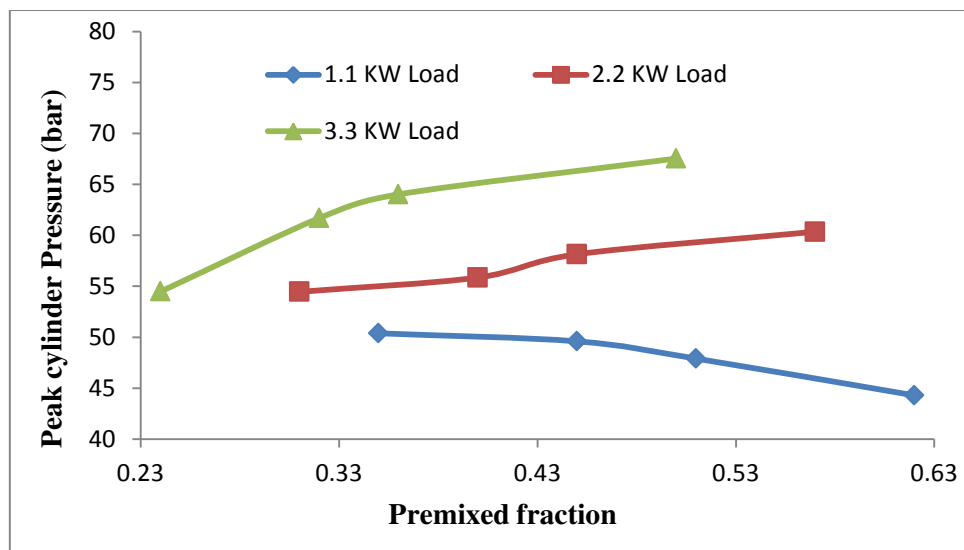
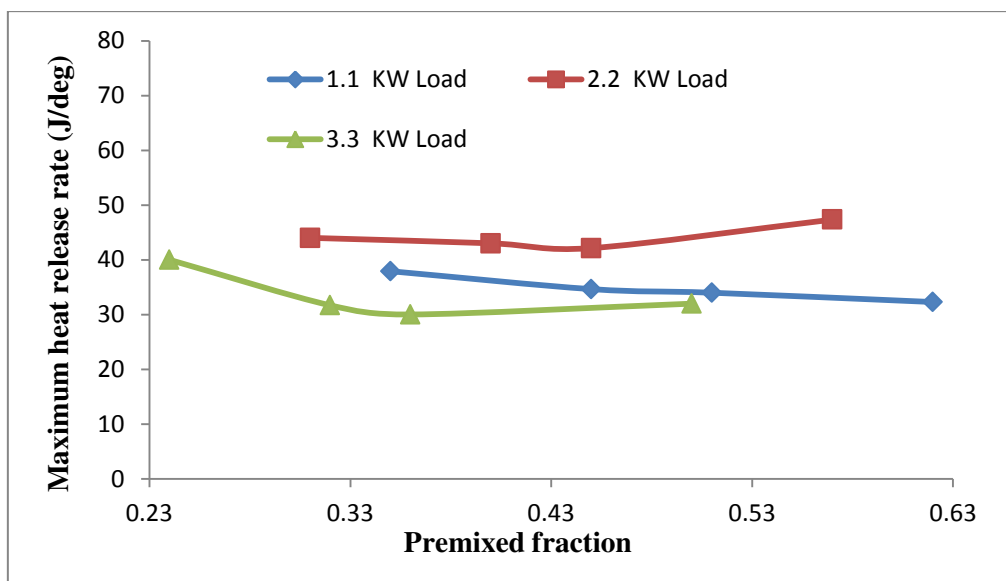

**Fig. 4.21 Variation of peak cylinder pressure with premixed fraction**

The peak cylinder pressure rises from 54.5 to 67.5 bar with increase in premixed fraction from 0.24 to 0.5 at 3.3 kW. This much increment of pressure is due to the early ignition of ethanol. Peak cylinder pressure increases 54.4, 55.8, 58.1, 60.3 bar with the increasing premixed fractions 0.31, 0.4, 0.45, and 0.57 respectively at 2.2 kW load. But at 1.1 kW, the peak pressure decreases up to 44.29 with increasing premixed fraction because of ethanol quenching.

#### 4.4.5 Maximum heat release rate

Fig. 4.22 depicts the variation of maximum heat release rate with respect to premixed fraction. The maximum heat release rate decreases 40 to 31.1 J/ °CA with increasing premixed fraction 0.24 to 0.32 at 3.3 kW load. This is due to two stage heat release separately, for ethanol and diesel. Without charge heating it happens only for full load but with charge heating, also happens for 3.3 kW. At 1.1 kW load, heat release rate decreases 37 to 32 J/deg with increase in premixed fraction 0.35 to 0.62, because of a inefficient combustion.

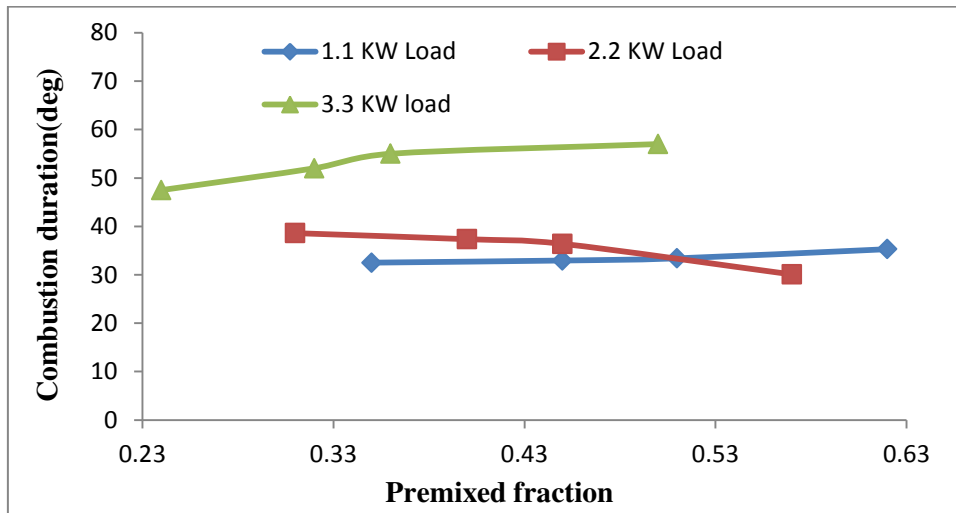

**Fig. 4.22 Variation of maximum heat release rate with premixed fraction**

#### 4.4.6 Combustion duration

In charge heating operation, the heated air is inducted into the cylinder, and the premixed ethanol absorbs the heat from air. Because of this combustion duration reduces in charge heating. Fig 4.23 depicts the variation of combustion duration with premixed fraction. At 3.3 kW load, combustion duration increases 47 °CA to 57 °CA with increase in premixed fraction

up to 0.5. The longer combustion duration is due to two stage combustion. At 2.2 kW, combustion duration decreases 38.6, 37.4, 36.4, and 30.0 with the increase in premixed fraction at 0.31, 0.4, 0.45 and 0.57 respectively. At 1.1 kW load, again combustion duration increases 32.51 to 35.29 with premixed fraction increased 0.35 to 0.62.

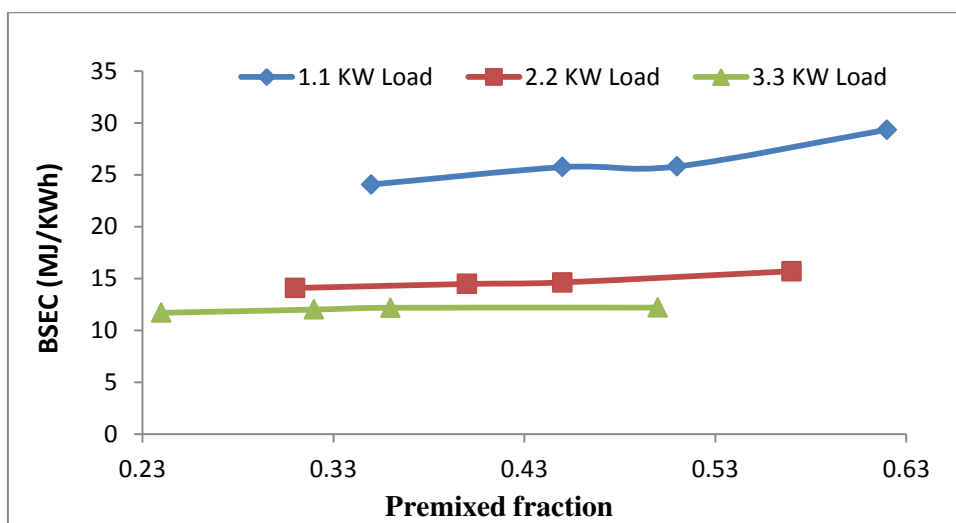

**Fig. 4.23 Variation of combustion duration with premixed fraction**

#### 4.5 Performance characteristics

##### 4.5.1 Brake specific energy consumption (BSEC)

Earlier result shows that BSEC increases dramatically with increasing premixed fraction at low load as the result of incomplete combustion and hence, large increment in UHC emission. Charge heating is used to reduce BSFC at low loads.



**Fig. 4.24 Variation of BSEC with premixed fraction**

Fig. 4.24 shows the variation of BSEC with respect to premixed fraction in charge heating operation. At 3.3 kW load, there is almost same result in compare to without heating, but for 2.2 kW BSFC decreases in comparison to without heating. At 2.2 kW, BSEC at premixed fraction 0.31, 0.40, 0.45, 0.57 is 14.08, 14.5, 14.6 and 15.7 MJ/kWh respectively. BSEC improve also for 1.1 kW load but only up to 50% premixing, further increase in the premixed fraction leads high increment in BSEC, from premixed fraction 0.51 to 0.62, increase in BSFC by 13.72 %.

#### 4.5.2 Exhaust gas temperature

The exhaust gas temperature mainly depends upon internal cylinder condition. Fig 4.25 shows the variation of exhaust gas temperature with respect to premixed fraction. In first module, it has shown dramatically increment in exhaust gas temperature at full load while two stage combustion. Same process repeat here at 3.3 kW load, exhaust gas temperature increases 331°C to 715°C with the premixed fraction 0.24 to 0.32. At 1.1 kW and 2.2 kW exhaust gas temperature increases 10° to 20° CA with increasing premixed fraction 0.3 to 0.62.

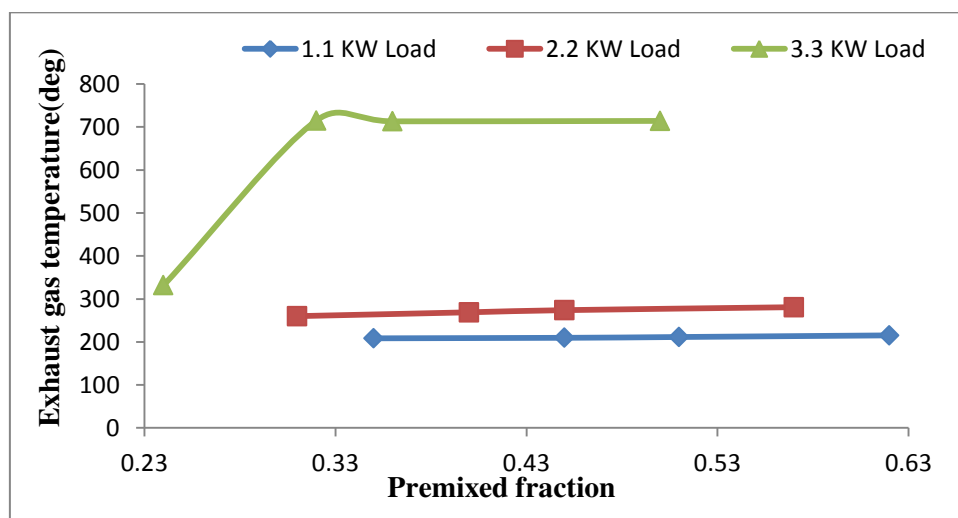

Fig. 4.25 Variation of exhaust gas temperature with premixed fraction

### 4.6 Emission characteristics

#### 4.6.1 Carbon monoxide

Inefficient combustion leads to the higher carbon monoxide percentage in exhaust gas. High CO emission in the exhaust is the clear indication of incomplete combustion of premixed mixture [6]. Fig. 4.26 depicts the variation of carbon monoxide with respects to premixed

fraction. At 1.1 kW load, increment in carbon monoxide at higher premixed fraction indicate incomplete combustion. The CO emission increases almost double with increasing premixed fraction 0.45 to 0.62. For 2.2 kW and for 3.3 kW loads, the CO emission reduces with the increased premixed fraction.

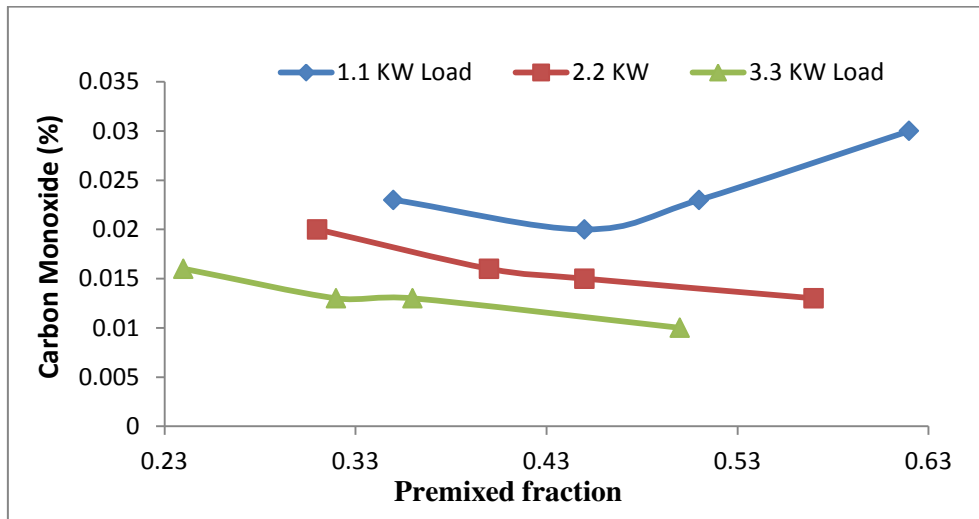

**Fig. 4.26 Variation of carbon monoxide with premixed fraction**

#### 4.6.2 Carbon dioxide

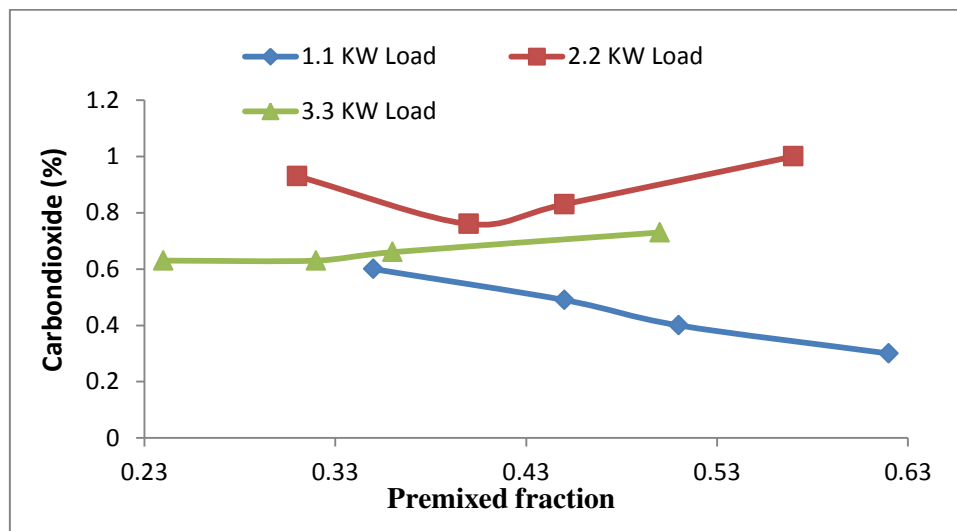

**Fig. 4.27 Variation of carbon dioxide with premixed fraction**

Variation of the carbon dioxide with premixed fraction for charge heating has shown in Fig 4.27 Carbon dioxide is directly proportional to in cylinder temperature and it is almost reciprocal of the carbon monoxide, increase in carbon dioxide indicates complete combustion. Charge heating improves the combustion performance and increase the in

cylinder temperature. At 2.2 kW load, without charge heating carbon dioxide decreased up to 0.4% but here, it increases up to 1%. Again for 1.1 kW load, carbon dioxide percentage reduces at higher premixed fractions as the result of incomplete combustion

#### 4.6.3 Hydrocarbon (HC) emission

Charge heating is reducing the HC emission and improves the BSEC. Fig 4.28 shows the variation of unburnt hydrocarbon with respect to premixed fraction. The HC emission increases with the increase in the premixed fraction. At 1.1 kW load, again UHC dramatically increases at higher premixed fraction but this times values are less than without charge heating values. From partial fraction from 0.51 to 0.62, it increases almost 50% at 1.1 kW. Other loads it increases normally.

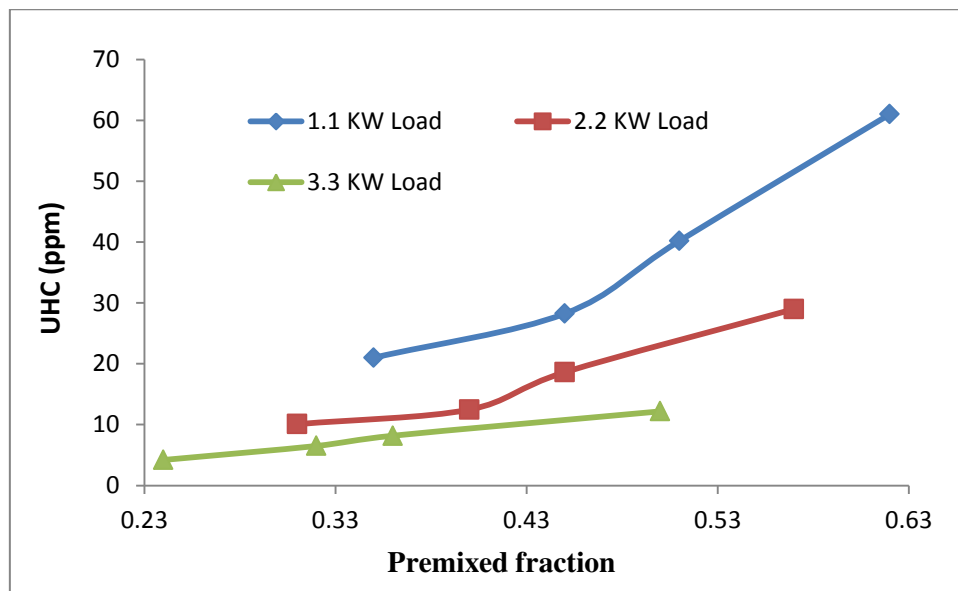

**Fig. 4.28 Variation of UHC with premixed fraction**

#### 4.6.4 Nitric oxide (NO) emission

Zhang chun-hua investigated, with the increase of intake temperature, the emissions of HC and CO decreases without increase in the NO for ethanol [22]. Fig 4.29 shows the variation of nitric oxide with respect to premixed fraction. At 1.1 kW and 2.2 kW, NO decreases up to 3 and 33.7 ppm respectively at higher premixed fraction. Moreover, at 2.2 kW values are more in comparison to without charge heating. NO increases up to 68.9 ppm at 3.3 kW.

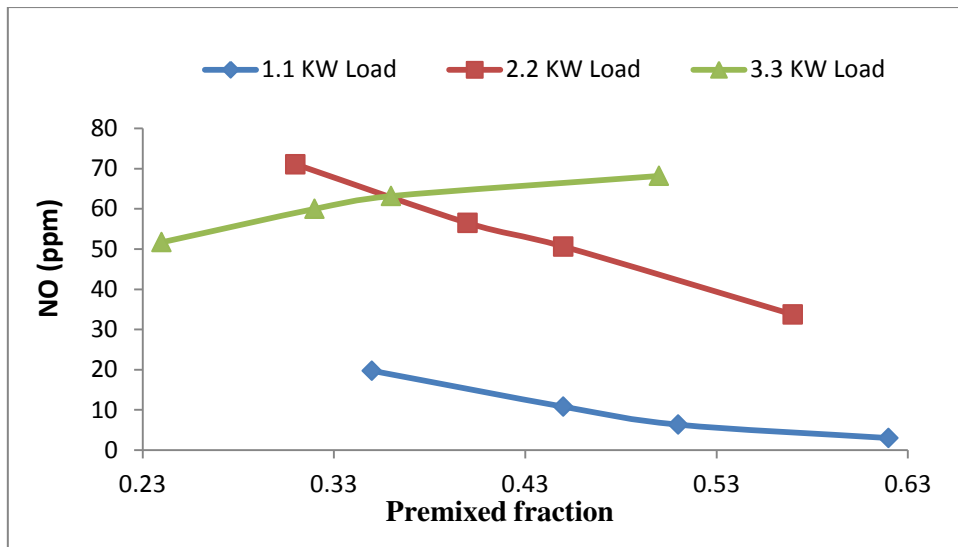

**Fig. 4.29** Variation of nitric oxide with premixed fraction

#### 4.6.5 Smoke opacity

Fig. 4.30 shows the variation of smoke opacity with respect to premixed fraction. The percentage of smoke opacity decreases with the increased premixed ratio. This is due to more homogeneous mixture and efficient combustion. In compared to first module, this module has low smoke opacity with respect to load and premixed fraction. At 1.1 kW, 2.2 kW and 3.3 kW minimum smoke opacity decreases up to 7, 19 and 26 % respectively

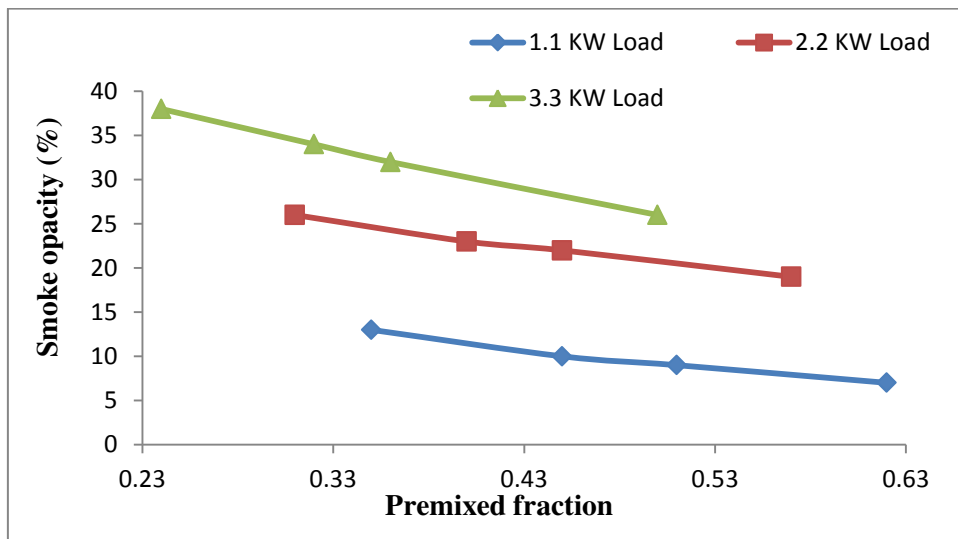

**Fig. 4.30** Variation of smoke opacity with premixed fraction



## CHAPTER 5

# **CONCLUSIONS & FUTURE SCOPE**

## 5.1 Conclusion

The combustion, performance and emission characteristics of 4 strokes, direct injection diesel engine developing power output of 4.4 kW at constant speed 1500 rpm, modified into PPCI combustion mode engine. Effect of various premixed fraction were investigated for all load separately.

The following are the conclusion from the first module;

1. At full load operation, low NO<sub>x</sub>, smoke opacity, CO and HC emission achieved up to the premixed fraction 0.40. Adverse effect of this is uncontrolled combustion after increase in premixed fraction 0.20. Hence, ethanol can be used up to premixed fraction 0.20 without any engine modification.
2. At 3.3 kW load operation, engine gives better combustion, performance and emission characteristics, low NO<sub>x</sub>, smoke opacity, CO and HC achieved up to 0.50 premixed fraction. Combustion is completely controlled, ignition start after diesel injection, no adverse effect.
3. At 2.2 kW load operation, low NO<sub>x</sub>, smoke opacity but, after increase in premixed fraction more than 0.3, increase in the BSEC as well as HC and CO emission also increases. It can be used only up to 0.3 premixed fractions, after increasing ethanol quantity, negative effect on all three combustion, performance and emissions characteristics.
4. At 1.1 kW load, ethanol shown completely worst results, inefficient combustion. Low NO<sub>x</sub>, smoke opacity but dramatically increased in HC emission, higher BSEC. Energy contribution of ethanol at higher premixed fraction almost negligible.

The conclusions from the second module are as follows,

1. After using charge heating of intake air at 110 °C, main advantage goes to 2.2 kW load. It has shown excellent improvement in the combustion, performance and emission characteristics with low NO<sub>x</sub>, smoke opacity, CO and HC achieved up to 0.62 premixed fractions. Start of combustion also controlled by diesel injection. No adverse effect on engine.
2. 1.1 kW load is also benefited by charge heating but up to some limit, less than premixed fraction 0.43. It is showing normal combustion property up to this limit.

In India, resources of ethanol are sufficient. It is obtained naturally and manufactured industrially. So, it can utilise in place of diesel to improve efficiency and economic condition both.

## **5.2 Future scope**

Low temperature combustion technologies shows promising future that is the only reason for leading automobile companies are searching opportunities in HCCI, PPCI, and other LTC combustion technology. As per the experiment, used ethanol with diesel has been proved the potential and fuel flexibility of PPCI combined combustion engine. In order to improving operating limit of this combustion system at higher load following methods can be used:

- Exhaust gas recirculation
- Cool air induction at intake manifold
- Advance injection of diesel

# CHAPTER 6

# REFERENCES

- 1 B.P. Pundir, Engine Emissions:Pollutant formation and advance in control technology. Alpha Science International Limited, 2007
- 2 V Ganesan IC Engine, New Delhi : McGraw- Hill Book Company; 2009
- 3 Sher, E, “ Environment Aspect of Air Pollution ” Handbook of air Pollution from Internal Combustion Engines : Pollutant Formation and Control, Ed, E. sher, Academic press, 1998
- 4 Seinfeld, J. H., Air Pollution-Physical and Chemical Fundamentals, McGraw Hill, Book Company New York (1975)
- 5 Kinney, P. L., "Airborne concentrations of PM 2.5 and diesel exhaust particles on harlem sidewalks: A community based pilot study", School of Public Health at Columbia University
- 6 Heywood JB. Internal combustion engine fundamentals. New York: McGraw- Hill Book Company; 1988
- 7 Maurya RK, Agarwal AK. Experimental study of combustion and emission characteristics of ethanol fuelled port injected homogeneous charge compression ignition (HCCI) combustion engine. Appl Energy 2011;88:1169–80.
- 8 Haoyue Zhu, Stanislav V. Bohac, Zhen Huang, Dennis N. Assanis Defeat of the Soot/NO<sub>x</sub> Trade-off Using Biodiesel-Ethanol in a Moderate Exhaust Gas Recirculation Premixed Low-Temperature Combustion Mode SEPTEMBER 2013, Vol. 135 / 091502
- 9 Vittorio Manente Bengt Johansson Pert Tunestal Characterization of Partially Premixed Combustion With Ethanol: EGR Sweeps, Low and Maximum Loads DOI: 10.1115/1.4000291
- 10 J. Hunter Mack et al. Demonstrating direct use of wet ethanol in a homogeneous charge compression energy 34(2009) 782-787
- 11 Samveg Saxena a,b,†, Silvan Schneider b, Salvador Aceves c, Robert Dibble ,Wet ethanol in HCCI engines with exhaust heat recovery to improve the energy balance of ethanol fuels applied energy 98 (2012) 448 457
- 12 D.Ganesh, G Nagarjun HCCI combustion of diesel fuel with external mixture formation energy 35 (2010) 148-157Suyin Gan, hoon kiat ng, Homogeneous Charge Compression Ignition (HCCI) combustion: Implementation and effects on pollutants in direct injection diesel engines applied energy 88(2011) 559-565

- 13 Akhilendra Pratap Singh, Avinash Kumar Agarwal Combustion characteristics of diesel HCCI engine: An experimental investigation using external mixture formation technique *Applied Energy* 99 (2012) 116–125
- 14 Bahram Bahri , Azhar Abdul Aziz , Mahdi Shahbakhti , Mohd Farid Muhamad Said Understanding and detecting misfire in an HCCI engine fuelled with ethanol *applied energy* 108 (2013) 24-35
- 15 Suyin Gan, Hoon Kiat Ng, Kar Mun Pang Homogeneous charge Compression Ignition (HCCI) combustion: Implementation and effects on pollutants in direct injection diesel engines. *Applied Energy* 88(2011) 559-567
- 16 L. Starck \*, B. Lecoite, L. Forti, N. Jeuland , Impact of fuel characteristics on HCCI combustion: Performances and emissions *Fuel* 89 (2010) 3069–3077
- 17 Mingfa Yao, Zhaolei Zheng, Haifeng Liu. Progress and recent trends in homogeneous charge compression ignition (HCCI) engines *Progress in Energy and Combustion Science* 35 (2009) 398-437
- 18 Abdul Khaliq a,\*, Shailesh K. Trivedi b, Ibrahim Dincer Investigation of a wet ethanol operated HCCI engine based on first and second law analyses *Applied Thermal Engineering* 31 (2011) 1621e1629
- 19 P A Lakshminarayanan Y V Aghav, A D Dani and P S Mehta. Accurate prediction of the rate of HR in a modern direct injection Diesel engine
- 20 Onishi S, Jo SH, Shoda K, Jo PD, Kato S. Active thermo-atmosphere combustion (ATAC) – a new combustion process for internal combustion engines. *SAE Paper* 790501; 1979
- 21 Annarita Viggiano , Vinicio Magi , A comprehensive investigation on the emissions of ethanol HCCI engines *Applied Energy* 93 (2012) 277–287
- 22 ZHANG Chun-hua, PAN Jiang-ru, TONG Juan-juan, LI Jing Effects of Intake Temperature and Excessive Air Coefficient on Combustion Characteristics and Emissions of HCCI Combustion, *Environmental Sciences* 11 (2011) 1119 – 1127
- 23 Junjun Ma\* , Xingcai Lü, Libin Ji, Zhen Huang An experimental study of HCCI-DI combustion and emissions in a diesel engine with dual fuel. *International Journal of Thermal Sciences* 47 (2008) 1235–1242.
- 24 Dong-bo Yang, Zhi Wang†, Jian-Xin Wang, Shi-jin Shuai Experimental study of fuel stratification for HCCI high load extension. *Applied Energy* 88 (2011) 2949–2954.

- 25 Horng-Wen Wu†, Ren-Hung Wang, Dung-Je Ou, Ying-Chuan Chen, Teng-yu Chen  
Reduction of smoke and nitrogen oxides of a partial HCCI engine using premixed gasoline and ethanol with air. *Applied Energy* 88 (2011) 3882–3890
- 26 Srinivas Padala , Changhwan Woo , Sanghoon Kook , Evatt R.Hawkes Ethanol utilisation in adiesel engine using dual-fuelling technology. *Fuel* 109 (2013)597–607
- 27 Xingcai Lu\*, Yong Qian, Zheng Yang, Dong Han, Jibin Ji, Xiaoxin Zhou, Zhen Huang Experimental study on compound HCCI (homogenous charge compression ignition) combustion fueled with gasoline and diesel blends. *Energy* 64 (2014) 707e718
- 28 Can Cinar \*, Özer Can, Fatih Sahin, H. Serdar Yucesu Effects of premixed diethyl ether (DEE) on combustion and exhaust emissions in a HCCI-DI diesel engine *Applied Thermal Engineering* 30 (2010) 360–365
- 29 Jianye Su, Haoyue Zhu, Stanislav V. Bohac Particulate matter emission comparison from conventional and premixed low temperature combustion with diesel, biodiesel and biodiesel–ethanol fuels *Fuel* 113 (2013) 221–227
- 30 Z.H. Zhang, C.S. Cheung, C.D. Yao Influence of fumigation methanol on the combustion and particulate emissions of a diesel engine *Fuel* 111 (2013) 442–448