

Electronic load as part of the test complex of the power processing unit of electric and plasma propulsion

S V Chubov and A I Soldatov

Tomsk Polytechnic University, 30, Lenina Ave., Tomsk, 634050, Russia

E-mail: Chubov@tpu.ru

Abstract. This article provides the advantages and technical solutions for the use of electronic loads as part of a testing complex of power and management systems of electric and plasma propulsion of three types. The paper shows the parameters that were applied to select the electronic loads and describes their functionality.

1. Introduction

The electric propulsion system based on the stationary plasma thruster (SPT) is currently widely used for the correction of the orbit of geostationary satellites. A power processing unit (PPU) is one of the main propulsion units, significantly affecting its output parameters and characteristics. The quality of testing PPU during ground tests largely depends on the extent to which the actual load simulations correspond to the real SPT [1 - 10]. The simplest equivalent of the SPT supply chain is resistive load, but it has several drawbacks when used under high power. The electronic intelligent load is a modern alternative solution of the classical embodiment of resistive load. Further researches using electronic loads are conducted to create and improve the PPU performance.

2. Materials and methods

The load of PPU is a chain of electric power supply SPT shown in figure 1, where A – anode; HC, HC(p) – primary and backup heaters of cathodes; IE, IE(r) – primary and backup ignition electrodes; MC – the magnetic coil (MC) which may have a series connection with the anode circuit without using additional power supply MC; FR, FR (p) – main and reserve flow regulators. In addition, the PPU load deals with an engine valve (EV), which is a part of the propulsion system (not shown in the image).

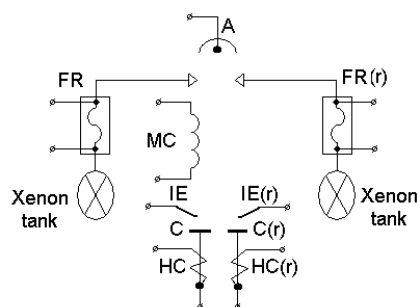

Figure 1. The structural scheme of the SPT power supplies circuit.

When testing PPU, the load is installed equivalently to the resistance circuits taking into account their inherent electrical parameters change during the operation within certain limits. Table 1 shows the electrical circuit of three different settings of engine types.

Table 1.The electrical parameters of the SPT power elements

Circuit	Parameter	Mode	Engine SPT-140D	Engine KM-75	Engine M-100	
A	U_A, V	Idling	≤ 350	≤ 900	≤ 350	
		Operating	300^{+15}_{-30}	810^{+25}_{-35}	300^{+15}_{-17}	
	I_A, A	P_k	4.5 ± 0.5	1.8 ± 0.2	1.5 ± 0.2	
		Nominal	15 ± 0.3	2.8 ± 0.1	4.5 ± 0.1	
		STZA	22 ± 1	3.7 ± 0.3	7.0 ± 0.7	
	R_A, Ω		11 – 79	193 – 522	36 – 243	
Type of loading (amount)		BK8522 (3 pcs.)	AKIP-1350 (1 pc.)	BK8522 (2 pcs.)		
HC	I_{HC}, A	$t=180 \mu s$	17 ± 0.5	8.5 ± 0.25	12 ± 0.3	
	R_{HC}, Ω		0.37 – 1.0	0.55 – 1.55	0.35 – 0.4	
	Type of loading (amount)		BK8510 (1 pc.)	BK8500 (2 pcs.)	BK8500 (2 pcs.)	
FR	I_{FR}, A	Standby	1.5 – 1.75	1.5 ± 0.5	1.5 ± 0.5 (3.6 – 4)	
		Nominal	0 – 4	0 – 4	0 – 4	
	R_{FR}, Ω		0.24 – 0.45	0.5 – 0.8	0.2 – 0.4	
MC	Type of loading			Resistive		
	I_{MC}, A		5.25 ± 0.25	$(6-10) \pm 0.25$	–	
	R_{MC}, Ω		1.1 – 3.2	0.85 – 1.65	–	
Type of loading (amount)		BK8500 (1 pc.)	BK8500 (1 pc.)	–		
IE	U_{IE}, V	Before ignition		320 ± 30		
		After ignition		20–40		
	R_{IE}, Ω	Before ignition	3 ± 0.5	10 ± 1	10000 ± 1000	
		After ignition	5 ± 0.5	20 ± 10	5 ± 0.5	
Type of loading			Resistive			
EV	U_{EV} / I_{EV}	Switching on	25–34V	$0.74 \pm 0.06 A$	22.3–32.7	
		Maintenance	$10.5 \pm 2.5 V$	$0.26 \pm 0.3 A$	8–13	
	R_{EV}, Ω		210 ± 5	8.5 ± 0.3	210 ± 5	
Type of loading			Active-inductive			

Two variants of the load can be considered as the equivalent circuits of the real engine power: resistive and electronic loads.

Resistive load, but it has several drawbacks when used under high power:

- allocation of a large amount of heat (Figure 2), which requires the use of additional forced cooling units both as a part of test equipment and indoors;
- great weight and size parameters, which have a negative impact on the transportation of the test set from a manufacturing organization to a customer organization;

- the inability to adjust the load resistance automatically;
- load resistance change due to the presence of the temperature coefficient;
- an inductive load component.

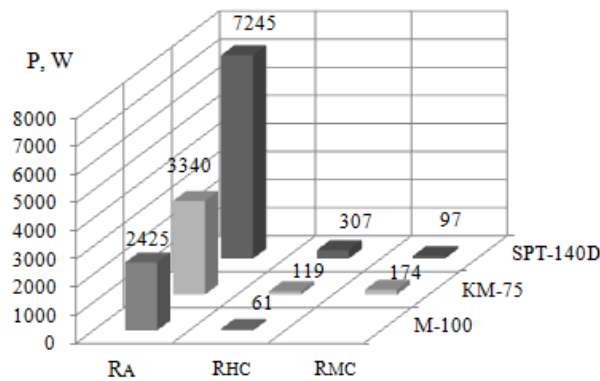

Figure 2. The load circuit power equivalent to various circuits engines (SPT-100D, KM-75, M-100).

Nowadays, there are many manufacturers, which produce electronic loads. The selection of these electronic loads to be used as a part of the PPU testing system is conducted according to the following specifications:

- the maintenance of required voltage, current, power, and a wide range of their control;
- the ability to control and manage the electrical parameters both via a digital display located on the front panel and via computer interfaces in order to integrate into an automated test equipment system;
- the high accuracy rates.

BK85hh (B&K Precision Corp.) and AKIP (PRODIGIT ELECTRONICS CO., LTD) machinery satisfy by the above-mentioned requirements. To solve the current issue, we can outline the most suitable models: BK-8500, BK-8510, BK-8522, AKIP-1350. For example, loads BK-8510 and BK-8522 (Figure 3) serve to simulate the engine SPT-140D elements on the test bench.



Figure 3. A test bench with electronic loads.

3. Results and discussion

Similar devices can be used as a complex and separately in various modes during the configuration, debugging, and testing of individual components and modules PPU. When checking the voltage sources, it is convenient to use the constant current mode (CC) when the setpoint current flows through

the electronic load. This current is maintained when the value of the input voltage changes. In a constant voltage mode (CV), the power sources are tested to determine their ability to limit the current. A constant resistance mode (CR) is needed for testing the power sources when determining the maximum possible outputted current values.

The check of PPU modes on the stand with electronic loads is based on the SPT work principle. The first stage is a work preparation, which includes the following stages: a cathode choice, power supply to the cathode heating circuit within 180 seconds, and standby mode of the flow regulator is provided. The flow regulator regulates the working substance flow supplied to the anode path from its storage unit. The HC circuit imitates the electronic load in a constant resistance (CR) mode (Figure 4). The flow regulator (FR) electronic circuit is a resistive one. The HC circuit resistance varies within a predetermined range (due to the electronic load functionality, it may vary automatically). At this point, the stabilization of I_{HC} heating current is controlled. Then the anode voltage of idling U_A is introduced to the process. The anodic load operates in a measurement mode. Ignition voltage is supplied to the ignition electrode with respect to a selected cathode in the form of pulses of positive polarity. After performing these manipulations, a real engine should start, and on the stand the inclusion of the plate load in a constant resistance mode is an imitation of the engine start. The discharge current I_A will appear in the A chain (between the anode and the cathode). The change of e-load resistance achieves the discharge current set point (approximately 0.3 times greater than the nominal value). Then, the PPU gives a 'P_K' command, which disables the cathode heat and transfers the flow regulator into the control mode depending on the discharge current. When I_A rises over the nominal limit, the current flow regulator also increases to a maximum value. This leads to the discharge current decrease. When the discharge current falls below the nominal value, the process is reversed. That is, flow regulator current is reduced to zero, and the discharge current increases. A significant increase of the nominal discharge current value results in PPU switching off the anode voltage and activating the overcurrent protection signal 'STZA'. This phenomenon is accompanied by abnormal processes in the engine.

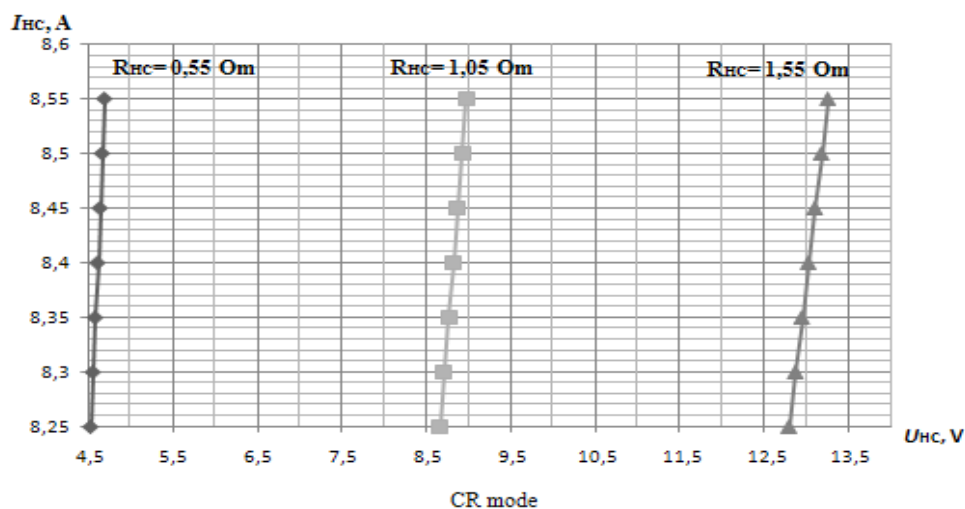

Figure 4. The HC circuit (Engine KM-75) imitates the electronic load in the operation CR mode.

It is important to note the following advantages of electronic loads BK85hh (B&K Precision Corp.):

- the possibility of a remote load control via serial interfaces (RS-232, USB) (Figure 5) using the following steps: the selection of a constant voltage mode, constant current, constant power, and constant resistance imitation, as well as the load imitation varying dynamically over time;

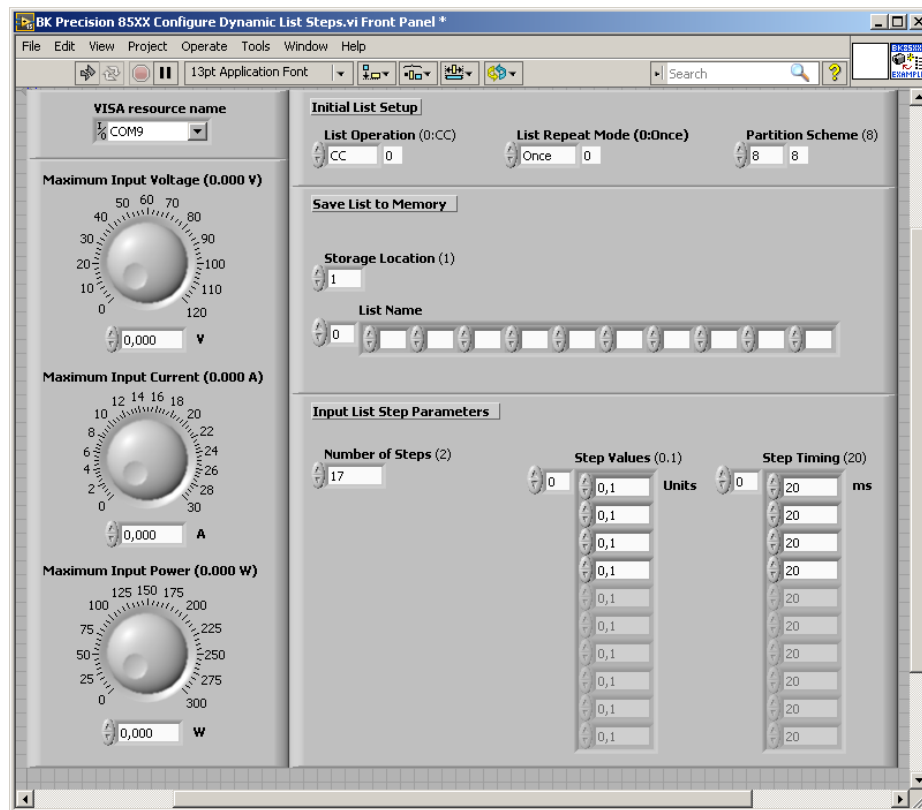

Figure 5. The software user's interface in a BK Precision 85xx LabView software.

- load shorting imitation;
- the connected source protection function which prevents excessive current levels, voltage, power, and reverse polarity;
- implementation of successive tests with multiple transitions states.

Electronic load AKIP -1350 has the following special features:

- the ability to operate up to 5 kW power at a maximum voltage of 1000
- simultaneous displaying of current, voltage, and power on a large LCD display
- five operating modes: constant voltage, constant current, constant resistance, constant power, a dynamic mode with a variable speed load growth (from 50ms to 10s).

When using the machinery of two manufacturers, one has the opportunity to install discrete input parameters.

4. Conclusion

When testing, the complex of electronic loads with a wide range of service functions, high accuracy performance, and serial interfaces allow the qualitative solution of the problems related to debugging, testing and PPU testing in an automatic regime using computer control. Thus, we can save the results on the computer and the subsequent analysis of emerging faults, the possibility of long-term continuous testing without the operator. In addition, it is possible to save results and the formation of the test report, a configurable test scenario, dynamic load changes from a minimum to a maximum and vice versa at different speeds.

References

- [1] Mikhailov M V and Moshnyakov A A 2015 *Proc. XIX Int. Scient. Conf. Reshetnev Readings (Krasnoyarsk)* Vol 1 (Krasnoyarsk: Siberian State Aerospace University Press) pp 165-167

- [2] Chernyshev A I, Shinyakov Y A, Galaiko V N, Volkov M P, Gordeev K G and Goroshkov I N The energy supply method of power electric plasma propulsion and its implementation machinery. Patent RF, no. 2220322, 2001
- [3] Katasonov N M Electric Plasma Propulsion Starting and Supply System. Patent RF, no. 2162623, 1999
- [4] Mikhailov MV, Katasonov NM and Chernishev A I 1998 *Proc. of KORUS'98 the 2-nd Int. Symp.* Vol 1 (Tomsk: TPU press) 528 p
- [5] Mikhailov MV, Katasonov N M and Chernishev A I 1999 *Proc. of the 3-rd Int. Symp. on Science and Technology (Novosibirsk)* Vol 2 (Novosibirsk: Novosibirsk State Technical University Press) 771 p
- [6] Katasonov N M Electric plasma propulsion simulator Patent RF No. 2395716, 2009
- [7] Mikhailov M V and Moshnyakov A A 2016 *Web of Conferences* 48 01007
- [8] Lazurenko A, Vial V, Bouchoule A, Skrylnikov A, Kozlov V and Kim V 2006 *J. of Propulsion and Power* 22(1) 38-47
- [9] Mukund R P 2005 *Spacecraft power systems* (Florida: CRC Press)
- [10] Lesnevskii V A, Mikhailov M V, Hodnenko V P and Khromov A V 2012 *Electromechanical matters VNIEM Studies* Vol 126 (Moscow: JC VNIEM Corporation) pp 25-28