

XIV Международная научно-практическая конференция студентов аспирантов и молодых учёных
«Молодёжь и современные информационные технологии»

RESEARCH OF THERMAL DEFORMATION OF A KINEMATIC WAVE REDUCER WITH A MODIFIED TOOTH PROFILE DURING THE WORK IN LOW TEMPERATURE CONDITIONS.

Stepanova D L, Nikulin P A
Krauinsh P J
Tomsk Polytechnic University
e-mail: pashanik91@gmail.com

Abstract. In the conditions of the Extreme North working resource of mechanical tools and machine elements is reduced because of bad weather conditions in this region. At a low temperature materials are exposed to deformation which is capable to break operability of the mechanism. In connection with the high requirements to the accuracy of a kinematic wave reducer, it is necessary to conduct a research for the purpose of comparison of value of thermal deformation and the appointed admission on a reducer detail. If value of thermal deformation is more admission, then it can lead to jamming of the mechanism. The research was conducted for a collected reducer and separately for not loaded driver gear.

1. Introduction

The simplified scheme of a reducer with the modified profile of tooth illustrated in the figure 1. This profile of teeth driven gear provides a possibility to create the transmission, which has a difference of teeth driver, and driven gear makes one tooth, it is a feature of a reducer with the modified shape of tooth. Use of a similar profile and a difference of teeth of a driver and driven gear provide the big area of contact, in comparison with evolvent gearing is reached that provides high load ability. Such difference allows receiving high value of load ability since loading is perceived by not one tooth, but several of teeth.

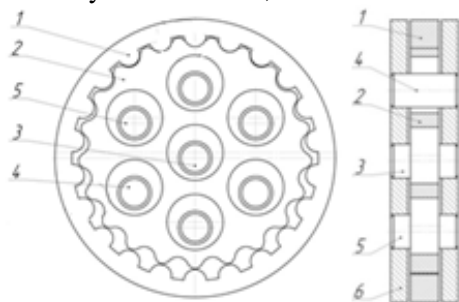

Fig 1. The simplified scheme of a reducer with the modified profile of tooth: 1 – Driven gear; 2 – Driver gear; 3 – Eccentric shaft; 4 – Hub; 5 – Fingers; 6 – Mobile wheel;

Analysis of the details of a reducer revealed that the most deformable detail is the driver gear. Deformation of the driver gear can lead to jamming of a reducer. Therefore, we will conduct a research of values of possible deformation for driver gear with the

purpose to exclude a possibility of jamming of a reducer under the influence of temperature changes.

2. The thermal deformation operating on a gear wheel.

Driver gear made of steel 40X GOST 4543-71. Let's define deformations of a gear wheel as separate detail. The driver gear is established on 4 bearings according to the kinematic scheme of a reducer. The research was conducted of using the SolidWorks Simulation program at a temperature of driver gear of -50°C .

Results of thermal deformation are visible in the figure 2. The figure shows that the maximum deformation is the share of points where amount of material the smallest and there are no support. In these points value of resultant movement makes 0.0201222mm (fig. 2a) and value of equivalent deformation makes 0.00149319 N/m^2 (fig. 2b).

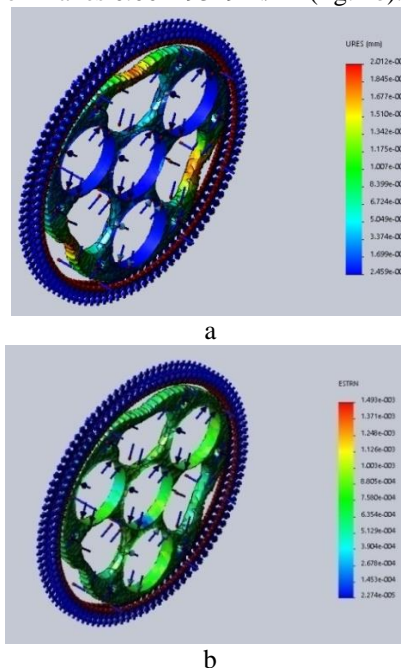

Fig. 2. Results of thermal deformation: a – value of resultant movement; b – value of tension

3. Thermal deformation on assembly of a reducer with temperature in a zone contact of teeth of a driver and driven gear $+90^{\circ}\text{C}$ and on all reducer assembly of temperature -50°C .

All parts of reducer made of steel 40X GOST 4543-71. As a result of the analysis diagrams of resultant movements and tension are received. The greatest

value of resultant movement on eccentric makes 0.00855mm (fig. 3), this value is less than value of a gap in bearings. The greatest value of tension makes $4.966 \cdot 10^7 \text{ N/m}^2$ (fig. 4), this value of tension doesn't exceed the yield strength of steel 40X $\sigma_t = 2.068 \cdot 10^8 \text{ N/m}^2$, it follows from this that durability of a design is provided.

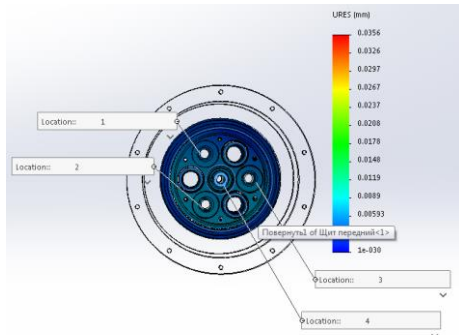

Fig. 3. Resultant movement on eccentric and input shaft: Location 1 – 0.00694 mm; Location 2 – 0.00829 mm; Location 3 – 0.00677 mm; Location 4 – 0.00855 mm.

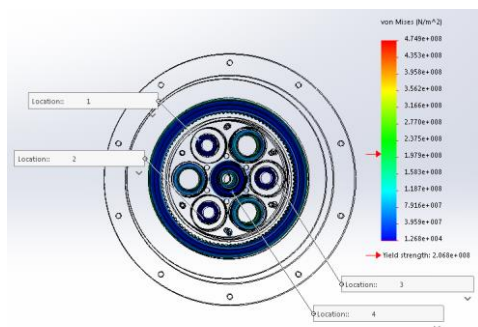

Fig. 4. Value of tension in eccentric: Location 1 – $4.506 \cdot 10^5 \text{ N/m}^2$; Location 2 – $2.024 \cdot 10^5 \text{ N/m}^2$; Location 3 – $6.232 \cdot 10^5 \text{ N/m}^2$; Location 4 – $4.966 \cdot 10^7 \text{ N/m}^2$.

4. Thermal deformation on assembly of a reducer with temperature in a zone contact of teeth of a gear wheel and a wheel + 90°C and on all reducer assembly of temperature + 50 °C.

All parts of reducer made of steel 40X GOST 4543-71. As a result of the analysis diagrams of resultant movements and tension are received.

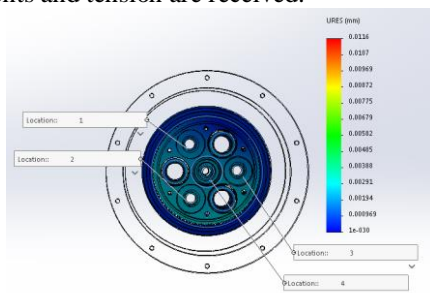

Fig. 5. Resultant movement on eccentric and input shaft: Location 1 – 0.00219 mm; Location 2 – 0.00293 mm; Location 3 – 0.0024 mm; Location 4 – 0.00298 mm.

The greatest value of resultant movement on eccentric makes 0.00298mm (fig. 5), this value is less than value of a gap in bearings. The greatest value of tension makes $1.865 \cdot 10^7 \text{ N/m}^2$ (fig. 6), this value of tension doesn't exceed the yield strength of steel 40X $\sigma_t = 2.068 \cdot 10^8 \text{ N/m}^2$, it follows from this that durability of a design is provided.

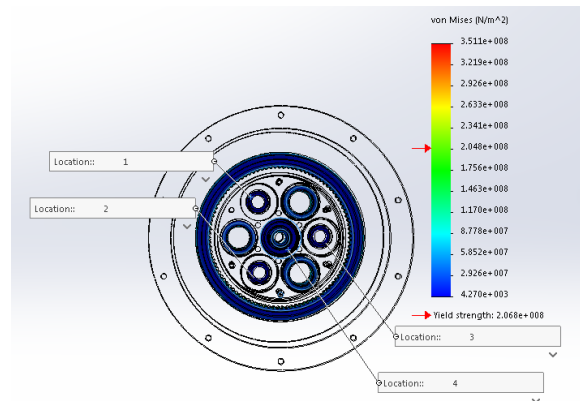

Fig. 6. Value of tension in eccentric: Location 1 – $2.001 \cdot 10^5 \text{ N/m}^2$; Location 2 – $1.004 \cdot 10^5 \text{ N/m}^2$; Location 3 – $2.517 \cdot 10^5 \text{ N/m}^2$; Location 4 – $1.865 \cdot 10^7 \text{ N/m}^2$.

4. Conclusion:

The mechanism has difficult geometry and to details great demands are placed on production accuracy. The thermal analysis has revealed that, the maximum resultant movement makes, at a temperature of influence of -50 °C on all details and +90 °C in a gearing zone of driver and driven gear makes 0.0225 mm. This value is less than value of the lower limit admission which makes 0,025 mm therefore this influence won't bring to get jammed a reducer.

References

1. Marisova A. F. Epicyclic gearing. Calculation and design // Rostov-on-Don. Don State Technical University, 2010. – p 85
2. Dunaev P. F., Lelikov O. P. *Construction components and machine parts* // Publishing center "Academy" 2008. – p 396
3. Fishenko V. N. Handbook for constructor. Book 2. Design mechanism and parts // Publishing center "Infra-Engineering" 2016. – p 400
4. Semenov Y. A. Semenova N. S., *Theory of mechanisms and machines* // Saint Petersburg Polytechnic University 2015. – p 284
5. Stepanova D. L. Kinimatic wave reducer with modify profile tooth. *Modern thecnics and thecnony* 2014 – p 201-202.
6. Stepanova D. L. Selection and justification of the winch drive parametrs with automatic control *Modern thecnics and thecnony*. 2014 – p 283-284
7. Luminarskiy I E 2014 *Theoretical studies of the kinematic error of a wave gear*. *Bullatin of University. Mechanical engineering*. T.648 №3 p 8-15