

Calculation of Free Interior Dimensions in Geokhod Transmission With Hydraulic Cylinders

M Yu Blaschuk, A A Dronov, S S Ganovichev

Yurga Institute of Technology, TPU Affiliate, 26, Leningradskaya Str., 652050,
Yurga, Russia

E-mail: mby.tpu@gmail.com

Abstract. Analytical expressions to specify overall dimensions of free interior in the geokhod, as well as its relation to design factors of a transmission and geokhod geometry are considered in the paper.

Introduction

Available technologies of mine working based on conventional tunnellers represented mainly by tunneling machines and shields have a number of drawbacks:

- tunneling equipment can't move through the rock mass in any direction of an underground space, i. d. the sphere of utilization is restricted by inclination angles of workings to be done;
- sufficient propulsive forces on the outer propulsive agent and crowding forces on a function agent can hardly be developed to disintegrate hard rocks;
- working in the bottom hole area can't be absolutely safe.

Tunneling machines of this kind are moved by outer propulsive agents – crawler, wheel, wheel-rail or walking brace ones. To develop propulsive forces on the outer propulsive agent and crowding forces on a function agent outer geological environment is not practically used but it is relied on a solid contact surface of geological environment and air or soil of a working (when performing it by a tunneling machine), or surface of a permanent support when shield tunneling. Therefore, a number of studies resulted in development of a geo-winchester technology of mine working, as well as in designing a machine to implement this technology – a geokhod [1].

Geokhods are a new class of tunneling machines distinguished by unconventional engineering solutions and principle of operation [1,2]. The main feature of a geokhod structure consists in two cylindrical sections. The head of the geokhod is burling along the stabilizing end section. The motor rotating the head is to be placed inside the geokhod on the periphery of section coupling. One of the key requirements these motors are to meet is a free space inside a geokhod to transfer the broken rock, to mount other systems, as well as for workers to perform maintenance and repair operations [1,3,4]. Various motors to rotate the head have been already studied [5], it had been revealed rotation transmission with hydraulic cylinders on geokhod chords is the most appropriate variant.



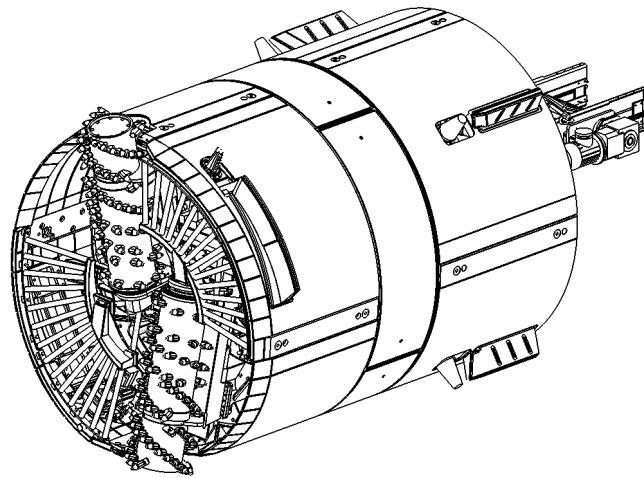

Figure 1. Geokhod

Results and Discussion

If hydraulic cylinders are placed on the circle chords in the space between the head casing and tail shell, design factors of transmission elements (features of hydraulic cylinders) are relevant for free space dimensions inside the geokhod [6]. The layout for calculation of free space inside the geokhod is given in Figure 2.

To eliminate spatial crossing of hydraulic cylinder elements with the head casing and tail shell a minimum positive allowance is necessary between a hydraulic cylinder and corresponding shells. Here, an allowance between a hydraulic cylinder casing and the outer surface of the tail shell is most relevant together with the dimensions $D_{PL.ROD}$, $D_{PL.HC}$, D_{HC} to calculate the maximal probable diameter of tail shell and interior size, respectively.

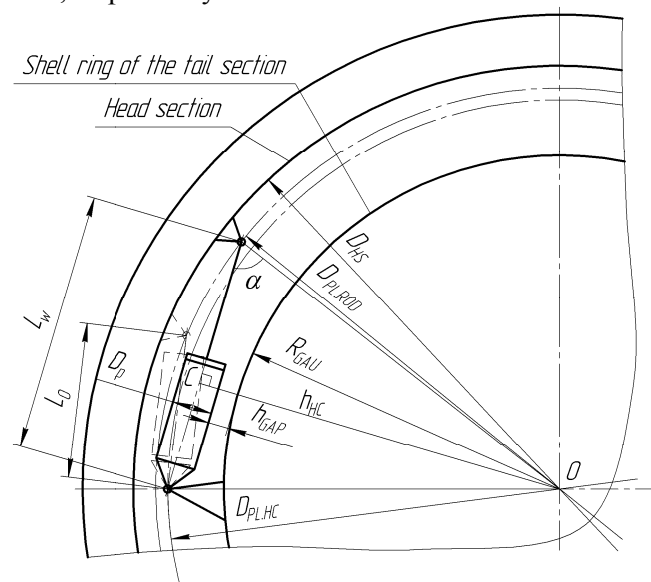

Figure 2. Analytical model to calculate overall dimensions of the interior

As one can see in Figure 2, a case of the hydraulic cylinder is inclined inwards the section, approaching maximally to its longitudinal axis in the end telescoping position under the constructional condition $D_{PL.ROD} \approx D_{PL.HC}$ (tongues of the case and a shaft of the hydraulic cylinder are nearly on the same circle) when the shaft is telescoping.

The shortest (nearest) distance from the longitudinal axis of the head (center O) to the case of the hydraulic cylinder is on the perpendicular OC to the longitudinal axis of the hydraulic cylinder (Figure 2). Then, the outer surface radius of tail shell R_{GAU} is calculated according to equation (1) provided that required allowance h_{GAP} is considered

$$R_{GAU} = h_{HC} - \frac{D_p}{2} - h_{GAP}, \quad (1)$$

where h_{HC} – the shortest distance (perpendicular) from the axis of the section to that of the hydraulic cylinder, m; D_p – diameter of the rod, m.

The distance h_{HC} is calculated according to the equation:

$$h_{HC} = \frac{D_{PL.ROD}}{2} \cdot \sqrt{1 - \frac{\left(\left(\frac{D_{PL.ROD}}{2} \right)^2 + L_w^2 - \left(\frac{D_{PL.HC}}{2} \right)^2 \right)^2}{D_{PL.ROD} \cdot L_w}}, \quad (2)$$

where $D_{PL.ROD}$ – diameter of shaft tongue rotating on the head section, m; $D_{PL.HC}$ – diameter of mounted tongues of hydraulic cylinder on the tail shell, m; L_w – the distance between tongues of the case and the hydraulic cylinder rod under maximal telescoping of a rod.

Substituting h_{HC} calculated in (2) into (1) it is obtained

$$R_{GAU} = \frac{D_{PL.ROD}}{2} \cdot \sqrt{1 - \frac{\left(\left(\frac{D_{PL.ROD}}{2} \right)^2 + L_w^2 - \left(\frac{D_{PL.HC}}{2} \right)^2 \right)^2}{D_{PL.ROD} \cdot L_w}} - \frac{D_p}{2} - h_{GAP}, \quad (3)$$

Taking into account various thicknesses of a case wall in a hydraulic cylinder [7,8] with respect to its structure and dimensions of the rod D_p one has to consider these parameters for the allowance size h_{GAP} . That is why; the distance from the axis of a hydraulic cylinder to the outer shell surface is to be expressed in terms of rod diameter D_p . Then, equation (3) is as follows

$$R_{GAU} = \frac{D_{PL.ROD}}{2} \cdot \sqrt{1 - \frac{\left(\left(\frac{D_{PL.ROD}}{2} \right)^2 + L_w^2 - \left(\frac{D_{PL.HC}}{2} \right)^2 \right)^2}{D_{PL.ROD} \cdot L_w}} - (0.75...1)D_p, \quad (4)$$

Under certain relations of dimensions $D_{PL.ROD}$, $D_{PL.HC}$ distance h_{HC} , calculated according to equation (2) can be smaller or comparable with dimensions $\frac{D_{PL.ROD}}{2}$, $\frac{D_{PL.HC}}{2}$. In this case R_{GAU} is dependent on dimensions $\frac{D_{PL.ROD}}{2}$ or $\frac{D_{PL.HC}}{2}$ provided that the necessary allowance h_{GAP} is taken into account (Figure 2). We can calculate equalities $h_{HC} = \frac{D_{PL.HC}}{2}$ and $h_{HC} = \frac{D_{PL.ROD}}{2}$ using Pythagorean theorem

$$h_{HC.ROT} = \frac{D_{PL.HC}}{2} = \sqrt{\frac{D_{PL.ROD}^2}{4} - L_w^2}, \quad (5)$$

$$h_{HC.ROT} = \frac{D_{PL.ROD}}{2} = \sqrt{\frac{D_{PL.HC}^2}{4} - L_w^2}, \quad (6)$$

The dependence of inner overall dimensions (Figure 3) on the number of hydraulic cylinders displays increasing number of hydraulic cylinders 5 to 14 is the reason for extending free interior, which is equal to 66 – 91% of the outer geokhod diameter. The increase in the free space together with the growing number of hydraulic cylinders is possible mainly because the hydraulic cylinders get smaller (D_p – diameter of rod), as well as their arrangement is more compact due to reduced shaft stroke and general extendibility of a hydraulic cylinder.

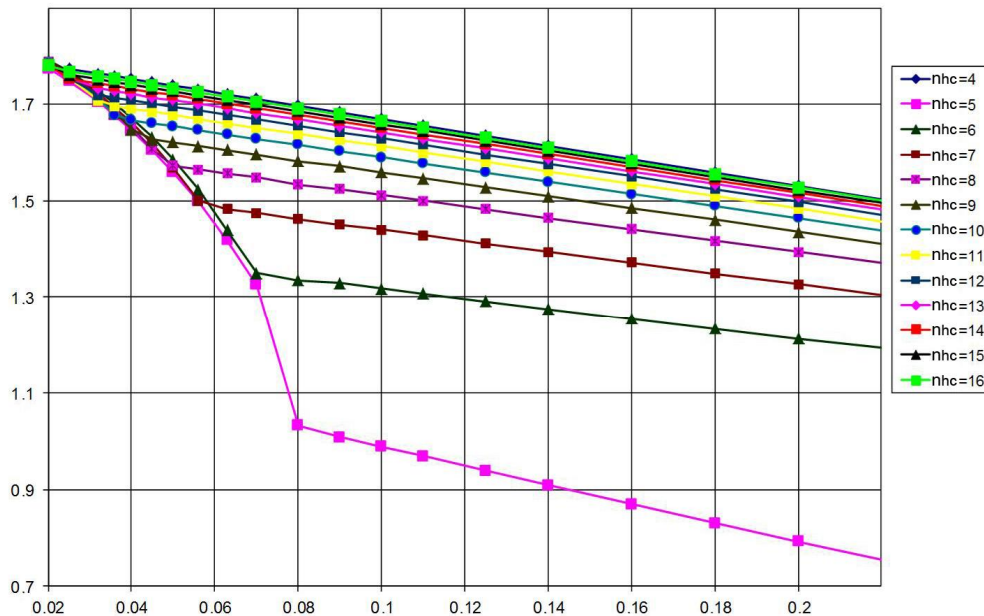

Figure 3. Overall dimensions of the interior in per cents of the head diameter D_{HS} according to the number of hydraulic cylinders n_{HC} .

More precise influence of accepted dimensions of hydraulic cylinders (D_p, L_w) and their number (n_{HC}) on the overall dimensions of free space in the geokhod can be determined with respect to geometrical parameters of hydraulic cylinders in geokhod transmission (Figure 4) [9].

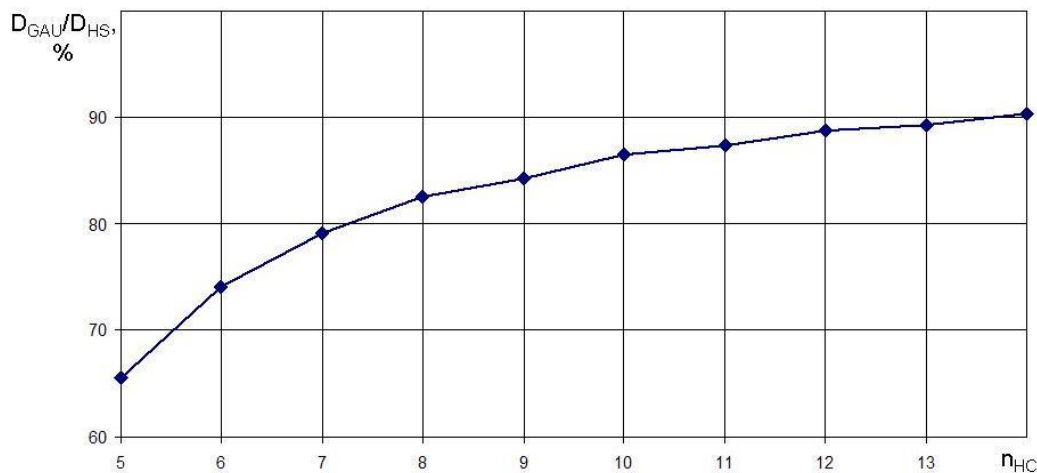

Figure 4 – The relation of distance R_{GAU} to the number of hydraulic cylinders n_{HC} placed on the chords inside the section for some rod diameters D_p .

These relations are specified for a geokhod with the diameter $D_{HS} = 3.7$ m, and the dimensions of hydraulic cylinders [9] meet the necessary value of the torque moment [10]. The relation is also relevant for other dimensions of a geokhod (Figure 3) as the dimensions of transmission change quite proportionally to changing its dimensions, this fact is obvious in the calculated radius of the inner space (R_{GAU}) of a geokhod with the following size series (Table 1).

Table 1. Geometrical parameters of geokhod transmissions and interior dimensions for the series of tunneling shields

	n_{HC} , items							
$D_{HS}=2.1$ m; $M_{ROT.REQ}=0.37$ MN·m	4	5	6	7	8	10	12	14
D_P , m	0.125	0.09	0.08	0.07	0.063	0.056	0.05	0.045
L_W , m	1.2	1.05	0.9	0.78	0.7	0.56	0.47	0.4
R_{GAU} , m	0.49	0.66	0.73	0.79	0.83	0.87	0.90	0.92
D_{GAU}/D_{HS} , %	60.20	65.60	73.40	79.32	82.35	87.15	88.93	90.10
$D_{HS}=2.6$ m; $M_{ROT.REQ}=0.73$ MN·m								
D_P , m	0.16	0.125	0.1	0.09	0.08	0.07	0.063	0.056
L_W , m	1.5	1.27	1.1	0.96	0.85	0.69	0.58	0.5
R_{GAU} , m	0.59	0.79	0.91	0.97	1.02	1.07	1.11	1.13
D_{GAU}/D_{HS} , %	60.11	65.48	73.18	79.22	82.05	86.97	88.76	90.50
$D_{HS}=3.2$ m; $M_{ROT.REQ}=1.43$ MN·m								
D_P , m	0.18	0.16	0.125	0.1	0.09	0.08	0.07	0.063
L_W , m	1.86	1.55	1.36	1.2	1.07	0.86	0.72	0.62
R_{GAU} , m	0.77	0.96	1.11	1.22	1.27	1.34	1.38	1.41
D_{GAU}/D_{HS} , %	60.24	65.57	73.55	79.47	81.98	87.23	88.75	90.35
$D_{HS}=4.1$ m; $M_{ROT.REQ}=4.43$ MN·m								
D_P , m		0.2	0.18	0.16	0.125	0.1	0.09	0.08
L_W , m		2	1.7	1.5	1.35	1.1	0.92	0.8
R_{GAU} , m		1.24	1.38	1.49	1.61	1.72	1.77	1.81
D_{GAU}/D_{HS} , %		65.42	73.42	79.24	82.22	87.02	88.53	90.27
$D_{HS}=5.6$ m; $M_{ROT.REQ}=10.7$ MN·m								
D_P , m					0.22	0.18	0.16	0.16
L_W , m					1.75	1.43	1.1	1
R_{GAU} , m					2.09	2.25	2.34	2.35
D_{GAU}/D_{HS} , %					82.12	87.05	88.62	90.52

Conclusion

It has been revealed the maximal dimensions of the free interior in the geokhod is possible if case supports and the rod of a hydraulic cylinder are placed on one circle, i. d. $D_{PL.ROD} \approx D_{PL.HC}$, it can be recommended for designing the transmission.

Provided that the number of hydraulic cylinders is increased 4 to 14 the dimensions of the interior gets extended by 66 to 91% of the outer geokhod diameter.

The radius share of free interior (D_{GAU}/D_{HS} , %) does not practically depend on changing the outer geokhod diameter, as dimensions of a transmission with hydraulic cylinders change proportionally to the change in outer geokhod diameter.

References

- [1] Aksenov VV, Khoreshok AA, Beglyakov VY. Justification of Creation of an External Propulsor for Multipurpose Shield-Type Heading Machine – GEO-WALKER. *Appl Mech Mater.* 2013 Aug;379:20–3.
- [2] Chernukhin RV, Dronov AA, Blashchuk MY. The application of the analytic hierarchy process when choosing layout schemes for a geokhod pumping station. *IOP Conf Ser Mater Sci Eng.* 2015 Sep 14;91:012086.
- [3] Aksenov VV, Blaschuk MY, Dubrovskii MV. Estimation of Torque Variation of Geohod Transmission with Hydraulic Drive. *Appl Mech Mater.* 2013 Aug;379:11–5.
- [4] Efremenkov AB, Aksenov VV, Blashchuk MY. Force parameters of geohod transmission with hydraulic drive in various movement phases. In: 7th International Forum on Strategic Technology (IFOST - 2012): Proceedings: in 2 vol [Internet]. IEEE; 2012 [cited 2015 Mar 6]. p. 159–63. Available from: <http://ieeexplore.ieee.org/lpdocs/epic03/wrapper.htm?arnumber=6357716>
- [5] Timofeev VY, Aksenov VV, Galjamova JI. Determination of Parameters of Roller of Wave Transmission with Intermediate Rolling Bodies with Hollow Shaft for Geokhod. *Appl Mech Mater.* 2014 Oct;682:246–50.
- [6] Efremenkov AB. Forming the subterranean space by means of a new tool (geohod). In: 6th International Forum on Strategic Technology (IFOST - 2011): Proceedings: in 2 vol [Internet]. IEEE; 2011 [cited 2015 Mar 6]. p. 348–50. Available from: <http://ieeexplore.ieee.org/lpdocs/epic03/wrapper.htm?arnumber=6021037>
- [7] Buyalich GD, Buyalich KG. Modeling of hydraulic power cylinder seal assembly operation. *Taishan Acad Forum - Proj Mine Disaster Prev Control.* 2014;167–70.
- [8] Buyalich GD, Buyalich KG, Voyevodin VV. Radial deformations of working cylinder of hydraulic Legs depending on their extension. *IOP Conf Ser Mater Sci Eng.* 2015 Sep 14;91:012087.
- [9] Buyalich GD, Anuchin AV, Dronov AA. The Numerical Analysis of Accuracy of Hydraulic Leg Cylinder in Modeling Using Solid Works Simulation. *Appl Mech Mater.* 2015 Jun;770:456–60.
- [10] Efremenkov AB, Timofeev VY. Determination of necessary forces for geohod movement. In: 7th International Forum on Strategic Technology (IFOST - 2012): Proceedings: in 2 vol [Internet]. IEEE; 2012 [cited 2015 Mar 13]. p. 1–4. Available from: <http://ieeexplore.ieee.org/lpdocs/epic03/wrapper.htm?arnumber=6357729>