

Nano-Disperse Borides and Carbides: Plasma Technology Production, Specific Properties, Economic Evaluation

G V Galevskii, Doctor of Engineering, Professor, V V Rudneva, Doctor of Engineering, Professor, S G Galevskii*, PhD in Economic Sciences, Associate Professor, K I Tomas, PhD in Engineering, Associate Professor, M S Zubkov**, Student, Group 10A42**

Siberian State Industrial University,
654007, Novokuznetsk, 42, Kirov str., tel. (3843)-74-89-13
*National Mineral Resources University (University of Mines)
199106, Saint-Petersburg, Vasilyeski Island, 2, 21st Line, tel. (812) 328-89-16
** Yurga Institute of Technology, TPU Affiliate, Yurga
652055, Kemerovo Region, Yurga, 26, Leningradskaya str., tel. (38451) 7-77-66

e-mail: kafcmet@sibsiu.ru, feanor1985@mail.ru*, tki@tpu.ru**

Abstract. The experience of production and study on properties of nano-disperse chromium and titanium borides and carbides, and silicon carbide has been generalized. The structure and special service aspects of utilized plasma-metallurgical complex equipped with a three-jet direct-flow reactor with a capacity of 150 kW have been outlined. Processing, heat engineering and service life characteristics of the reactor are specified. The synthesis parameters of borides and carbides, as well as their basic characteristics in nano-disperse condition and their production flow diagram are outlined. Engineering and economic performance of synthesizing borides in laboratory and industrial conditions is assessed, and the respective segment of the international market as well.

The work is performed at State Siberian Industrial University as a project part of the State Order of Ministry of Science and Education of the Russian Federation № 11.1531/2014/K.

1. Introduction

Over 1.5 milliard tons of steel – the most common structural material were manufactured for the first time in 2011 all over the world. In the pattern of structural materials the share of alloys based on ferrum is 95%, that of non-ferrous metals and alloys – 4%, all the others – below 1%. However, the last group includes materials of special purposes, has a wide range and is extraordinary important for present day civilization. It consists of materials meeting the criteria “refractoriness”, “super-hardness”, “heat resistance” and “high-temperature strength”, which are necessary to solve numerous innovative academic and technological, and engineering problems. That is why, materials based on carbides, borides, nitrides, silicides and their composites are of key importance in this group. In development of their national technological base the following stages can be singled out. In the 50-60s the Institute for Problems of Materials Science and Superhard Materials Institute of National Science Academy of



Ukraine promoted the study on their properties and developed technologies of their production and use. In the 70-80s some regional scientific centers – branches of academic Institutes in Moscow, Kiev, Riga and Novosibirsk made efforts to develop production and support the use of these materials in fine dispersion. The 2000s were distinguished by engineering progress, which is still in process and involves development of nano-technologies and nano-materials at a new level.

At present Russia is among the leaders in terms of carried out research into nano-technology but is rather inferior in respect of manufacturing nano-products and their export [1-5]. In line with the President's initiative, dated 24th April 2007 «The strategy of nano-industry development» the system of state support for this fundamental and applied research was established, which provides integration and concentration of state and private business resources, development of national nano-technological infrastructure, enhancement of efficiency of nano-products commercialization and their transfer, and focusing the efforts on the most commercially advantageous ones. Among these products there are functional, structural and composite nano-materials.

In the Siberian region of the Russian Federation the foundation of plasma-metallurgical nano-technologies of high temperature super-hard materials was laid by the school of academician of the Russian Academy of Sciences M.F. Zhukov, who joined efforts of research teams of academic, industrial and educational institutions in Western and Eastern in the early 1970s Siberia in order to produce and apply various nano-powders in laboratory conditions. The results of this research were presented in multi-volume sets published in Russia and abroad «Low temperature plasma» (editor-in-chief academician RAS M.F. Zhukov), «Thermal plasma in the technology of new materials» (science editor academician RAS M.F. Zhukov), «Nano-materials and nano-technologies in silicon carbide production» (science editor professor G.V. Galevskii) etc. In the course of investigations the functionality of plasma-technological equipment was proved, as well as the possibility to synthesize and apply nano-scaled carbides, borides, nitrides in new fields. However, social and economic transformations in Russia at the turn of the 1990s were the reason for cancelled investments in this research domain, made impossible and uncalled the transition to the industrial scale and commercialization of the products.

In conditions of the evolving in the 21st century nano-technological development we suppose further research into organization of industrial plasma-metallurgical production of high temperature chemical compounds and identification of foreground spheres of their application in ceramic, galvanic, metallurgical and other technologies is the important scientific and economic problem, which is relevant for the State Program «Science and technologies development for the period through 2020».

The aim of this paper is to generalize the long-term experience and results obtained by Siberian State Industrial University when developing main equipment and adopting production technologies of nano-disperse chromium, titanium and silicon borides and carbides. Production technologies of borides and carbides were selected as the object of research due to the favourable combination of their consumer properties (hardness, refractoriness, wear resistance and high temperature strength); availability of raw materials; relatively simple synthesizing in the furnace as the basic technology; stable demand of consumers, particularly for coating materials, materials of functional coatings and modifying complexes, which provide three(four)fold increase in the life cycle of products and tools; and real possibility of attaining new effects when using them in nano-condition.

2. Plasma-technological equipment: structure, operation, characteristics.

For experimental study on the synthesis and production of borides and carbides Siberian State Industrial University in collaboration with experimental and production company “Polymet” developed a plasma-technological complex (Figure 1), excelling previous experimental facilities in the key characteristics. The structures of plasmatrones, mixing chambers, dosing units of burden charge, and bag collector are protected by patents of the Russian Federation № 66877, 107440, 108319, 184916. The main characteristics of the reactor are listed in Table 1. In papers [6, 7] heat engineering, performance and processing characteristics are described in more details. The plasma-technological complex consists of a three-jet reactor and the systems of power, gas, and water supply and ventilation, supervisory instruments and automatic devices, burden charge dosing units, and devices of nano-disperse products

entrapping and neutralization of emitted process gases.

To generate the plasma flux three arc heaters of gas (plasmatrones) EDP-104AM with the capacity 50kW per a facility are used, they are mounted in the mixing chamber at an angle 30° to the reactor axis. Plasmatrones EDP-104AM run on direct current and require for the following parameters of the electric arc: arc voltage to 250V, current to 200A. The stabilization of the electric arc is gas-vortex due to the tangential input of plasma-generating gas through a special tightening ring. The water-cooled copper anodes of plasmatrones with the inner diameter of 0.008 m have practically unrestricted life time provided that they are cooled and run in the mixing chamber with plasma jets inclined at an angle 30° . The cathodes of plasmatrones consist of water-cooled copper bodies and cathode inserts made of thoriated tungsten (to reduce the work function of electrons) with the diameter of 0.003 m and life time 100 – 120 hours. Plasmatrones are switched on by oscillators. Plasmatrones EDP-104AM differ from the basic model as technically pure nitrogen with 1.5 – 2.0 volume % oxygen meeting the actual standard of currently supplied technical nitrogen can be used as a plasma-generating gas. Plasmatrones are supplied with electric power from the thyristor transformer AT4-750/600, distinguished by the steeply-falling volt-ampere characteristic and the following operating parameters: power, kW – 450; rectified voltage, V – 600; rectified current, A – 750; efficiency factor in nominal conditions, % – 96; voltage in the supply main, kW – 6.

Fine-grained raw materials are efficiently input into the reactor, mixed with a plasma flux due to the structure of the mixing chamber, moreover, the life time of plasmatron anodes is quite unrestricted. The mixing chamber is joined to the divided water-cooled channel with the inner diameter of 0.064 m. The mixing chamber and reactor sections are made of stainless steel. Fine-grained raw materials are fed into the reactor by a water-cooled tuyere. The tuyere is used also to supply gas hydrocarbon into the reactor. The reactor channel is lined inside with high-temperature heat-insulating material in order to reduce the radial gradient of the temperature near its walls.



Figure 1. Industrial plasma-technological complex

| Table 1. Basic characteristics of the reactor | |
|---|--------------------------------------|
| Characteristics | Values |
| Capacity, kW | 150 |
| Type of the reactor | Three-jet Direct flow Vertical |
| Type of the plasmatron, power, kW | EDP-104A, 50 |
| Plasma-generating gas | Nitrogen |
| Mass of the heated gas, kg/h | 32.5 |
| Inner diameter, m | 0.054 |
| Volume of the reactor, m ³ | 0.001 |
| Lining of the reactor channel | Zirconium dioxide |
| Temperature of plasma flux, K | 5400 (L*=0) – 2200 (L=12) |
| Temperature of lining, K | 1549 (L=0) – 770 (L=12) |
| Specific electric power, MW/m ³ | 2142 |
| Life time: - anode | 3125 |
| - cathode | 112 |
| Contamination of borides and carbides with erosion, % | |
| - anode | Cu – 0.0000954% |
| - cathode | W – 0.0000002% |
| L* - relative length of the reactor | |

Powdered raw materials are measured out in doses by the batch type electromechanical and gas vortex dosing unit with the removable cylinder – receiver of powdered raw materials, intended for poorly flowing fine-dispersed raw materials.

The entrapping system consists of a settling chamber, providing the temperature decrease of process gases to 2800 – 2000 K and trapping of 10 % nano-powder, and two bag filters working by turns (trapping up to 85 % nano-powder). The reagent is fed by the water-cooled probe into the settling chamber, which passivates and coagulates nano-powders. The filters are made with a water-cooled body, and a filtering bag is refreshed by compressed air (nitrogen) blowing. Filter cloth is twill weave chromium-nickel steel wire mesh.

The plasma-technological complex excels available laboratory and experimental industrial facilities in power four-five folds, life time three-four folds, efficiency 2.5 – 3.5 folds.

3. Production and properties of boride and carbide nano-powders

The results of research into plasma-technological production of borides and carbides are presented in details in a great number of papers published at different times; inter alia [8-15].

The development and adoption of plasma-technological production of chromium, titanium and silicon borides and carbides comprises two phases: 1) the study on formation processes of borides and carbides and physical-chemical properties of nano borides and carbides; 2) industrial adoption of the studies technological samples.

The first phase focuses on the simulation of reaction of material flow with the plasma flux, experimental study, discussing the mechanism of boride and carbide formation, and physical and chemical assessment of nano-dispersed products. The equations describing the relation of borides and carbides concentration to the basic process factors (1.1 – 1.5), tolerances of the change in formation of borides and carbides in industrial reactor with the capacity of 150 kW, main characteristics of borides and carbides (Table 2) and their photomicrographs (Figure 2) are given below.

$$[\text{CrB}_2] = -413.53 + 0.09695 T_0 + 2.283 [\text{B}] + 0.1736 \{\text{H}_2\} - 0.00058 T_0 [\text{B}]; \quad (1.1)$$

$$[\text{Cr}_3(\text{C}_{0.8}\text{N}_{0.2})_2] = -66.12 + 0.03 T_0 - 0.42 \{\text{H}_2\} - 0.14 \{\text{N}\} - 0.00002 T_0 \{\text{N}\}; \quad (1.2)$$

$$[\text{TiB}_2] = -412.41 + 0.09489 T_0 + 2.196 [\text{B}] + 0.1597 \{\text{H}_2\} - 0.00061 T_0 [\text{B}]; \quad (1.3)$$

$$[\text{TiC}] = 17.3211 + 0.0105 T_0 - 0.0156 T_3 + 0.1859 \{\text{CH}_4\} - 3.432 \{\text{H}_2\} - 0.4078 \{\text{N}\}; \quad (1.4)$$

$$[\text{SiC}] = 86.50 + 0.00273 T_0 - 0.0064 T_3 - 0.144 \{\text{CH}_4\} + 0.00007 T_3 \{\text{CH}_4\}, \quad (1.5)$$

where T_0 – initial temperature of the plasma flux, K; T_3 – hardening temperature of products of boride and carbide formation; $[\text{B}]$ – concentration of boron in the furnace burden (% of stoichiometrically required); $\{\text{CH}_4\}$ – hydrocarbon content (% of stoichiometrically required); $\{\text{H}_2\}$ – hydrogen concentration in a plasma-generating gas, volume %; $\{\text{N}\}$ – content of elemental nitrogen in a plasma-generating gas (% of stoichiometrically required for hydrogen cyanide).

The second phase was concentrated on development of reference documents (technical conditions and technological processes) and production flow diagrams of technologies to synthesize borides and carbides proposed by experimental and production company “Polymet”, main engineering and economic factors are calculated. Figure 3 outlines an example of a production flow diagram of chromium carbonitride (I) and carbide (II) synthesizing.

| Parameters of synthesis and characteristics | CrB ₂ | Cr ₃ (C _{0.8} N _{0.2}) ₂ | TiB ₂ | TiC | SiC |
|---|---------------------|---|---------------------|--------------------|--------------------|
| Chemical composition of the exchange gas, volume %: - nitrogen / hydrogen / methane | 74/25/1 | 99/-/1 | 74/25/1 | 99/-/1 | 99/-/1 |
| Technological variant of synthesis | Cr+B+H ₂ | Cr+CH ₄ | Ti+B+H ₂ | Ti+CH ₄ | Si+CH ₄ |
| Efficient use of raw materials, kg/h | 3.6 | 3.1 | 3.6 | 3.2 | 3.0 |
| Boron content in the furnace burden, % of stoichiometrically required | 100-120 | – | 100-120 | – | – |
| Content of carbonization agent, % of stoichiometrically required | – | 120-140 | – | 120-140 | 120-140 |
| Initial temperature of the plasma flux, K | nm 5400 | nm 5400 | nm 5400 | nm 5400 | nm 5400 |
| Hardening temperature, K | 2600-2800 | 2000-2200 | 2600-2800 | 2600-2800 | 2800-3000 |
| Phase composition | CrB ₂ | Cr ₃ (C _{0.8} N _{0.2}) ₂ | TiB ₂ | TiC | β-SiC |
| Main phase content, % | 92-93 | 92-93.5 | 92-93 | 93-93.5 | 91-92 |
| Main phase output, % | 91-92 | 90.5-91.5 | 91.5-92.5 | 92-92.5 | 87-90 |
| Efficiency, kg/h | 3.0 | 3.4 | 3.4 | 3.7 | 4.05 |
| Intensity, kg/h·m ³ | 1364 | 2010 | 1980 | 2105 | 2200 |
| Specific surface, m ² /kg | 33000-35000 | 31000-35000 | 46000-48000 | 33000-35000 | 40000-44000 |
| Size* of particles, nm | 42.0 | 34.0 | 36.0 | 35.0 | 55.0 |
| Form of particles | Spherical | Spherical | Spherical | Faceted cube | Faceted |
| Oxidation** of nanopowder x10 ⁷ , kg O ₂ /m ² | 9.0-9.7 | 8.0-10.0 | 5.8-7.6 | 8.5-9.5 | 6.5-8.0 |
| * - specified according to the specific surface; ** - specified after air storage for 24 hours | | | | | |

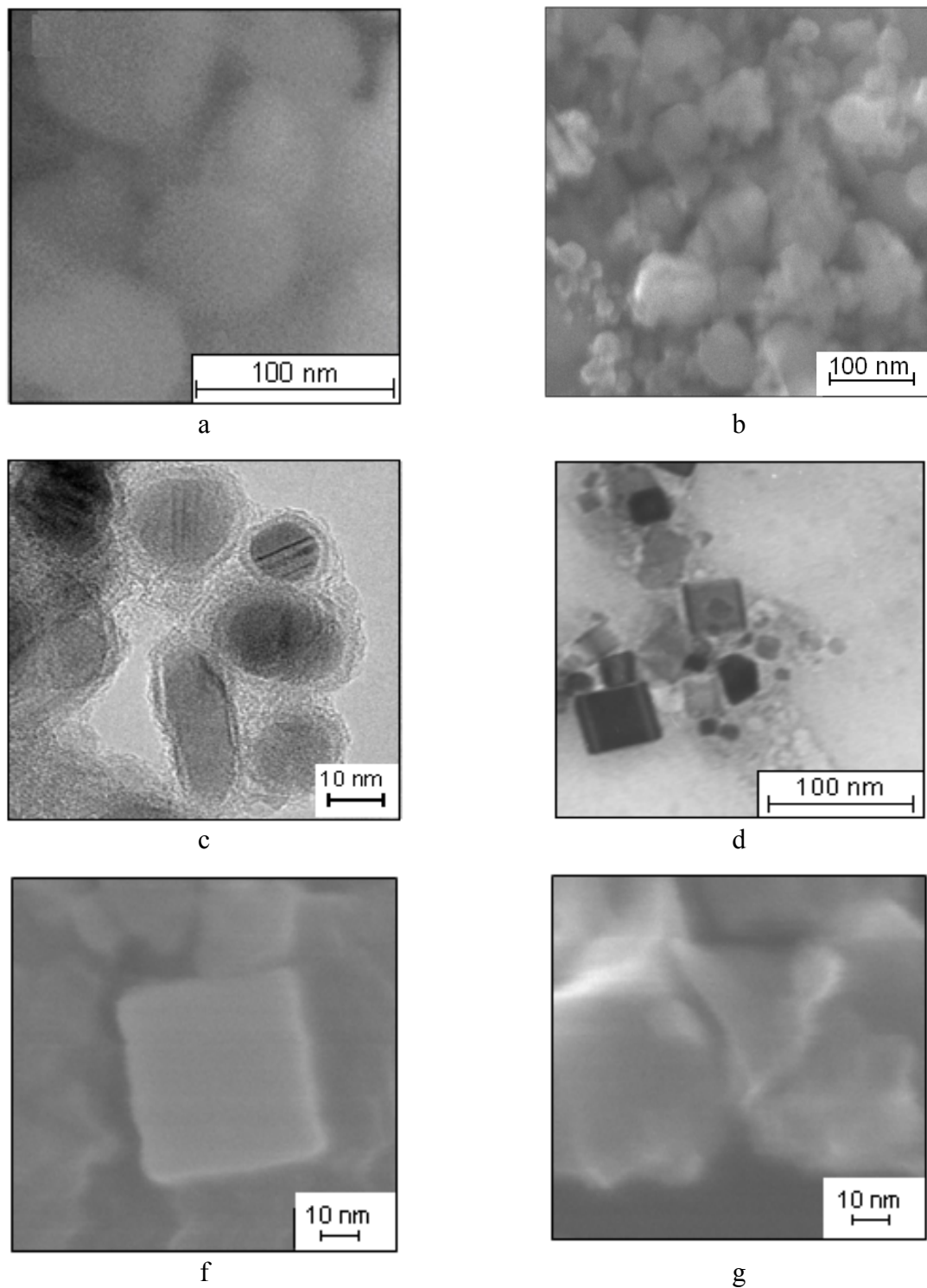
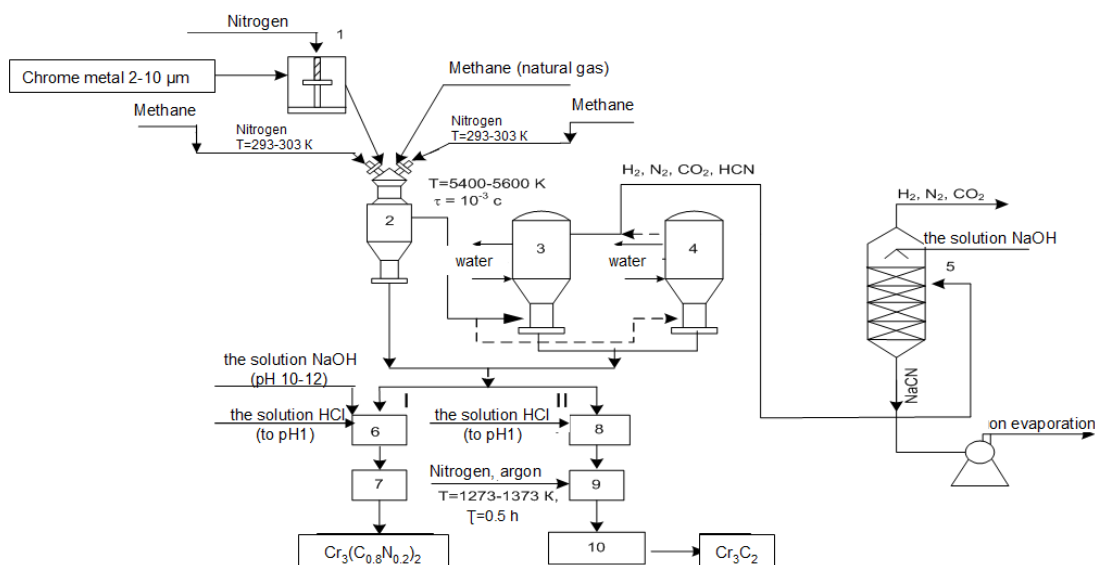

Figure 2. Photomicrographs of chromium boride and carbonitride nanopowders (a, b), titanium boride and carbide (c, d), silicon carbide (f, g)



1 – furnace burden measuring out in doses; 2 – synthesis; 3, 4 – separation of the end product; 5 – absorption process of decontaminating emitted gases; 6, 7 – refining chromium carbonitride and control of its characteristics, 8, 9 – refining chromium carbonitride and its additional carbonation, 10 – control of chromium carbide characteristics

Figure 3. Production flow diagram of chromium carbonitride (I) and carbide (II) synthesis

4. Economic assessment

Introduction of boride and carbide nanopowders into industrial production create the necessary prerequisites for their wide application, at least on the homeland market of nano materials. Table 3 outlines the results of comparing main technical and economic factors of synthesized chromium boride and carbide, and silicon carbide in laboratory and industrial conditions.

| Table 3. Comparison of technical and economic factors of nanopowders synthesized in laboratory and industrial conditions | | | |
|---|------------------|--------------------------------|-----------|
| Technical and economic factors | CrB ₂ | Cr ₃ C ₂ | SiC |
| Maximal capacity of the reactor, kW | 150/50 | 150/50 | 150/50 |
| Main phase content, % | 95.0*/81.0** | 96.0/81.0 | 99.0/94.0 |
| Oxidation x10 ⁷ , kg oxygen/m ² | 8-10/18-20 | 12-14/9-11 | 0.8/6.7 |
| Efficiency, t/year per a reactor | 3.2/0.5 | 3.6/0.6 | 3.1/1.8 |
| Intensity, kg/h·m ³ | 1365/265 | 1360/245 | 1210/605 |
| Specific electric energy consumption, thousands kW·h/t | 75/145 | 69/140 | 74/115 |
| Technical and economic factors | CrB ₂ | Cr ₃ C ₂ | SiC |
| Cost price, thousand rubles/kg | 6.2/15.8 | 6.6/14.5 | 6.0/11.0 |

*/** - laboratory and industrial conditions

World key developers and producers of nano materials based on borides and carbides are experimental and production companies «Nanostructured & Amorphous Materials, Inc.» (the USA), «Tokyo Tekko Co» (Japan), «Hefei Kaier Nanotechnology & Development Ltd. Co» (China), «NEOMAT Co» (Latvia), «PlasmaChem GmbH» (Germany), selling them at the price about 1200 \$/kg; quality and dispersion are comparable [2-5].

Conclusions

The carried out analysis proves the possibility of industrial plasma-technological synthesizing high-temperature superhard titanium, chromium and silicon borides and carbides provided that technological complex equipped by three-jet direct flow reactor with the capacity of 150 kW is used as a base model. Industrial synthesis supports achieving quality, technical and economic standards similar to the world counterparts, and competitive ability of scientific and technical products.

References

- [1] Galevskii G V Nanomaterials and nanotechnologies: assessment, tendencies, and forecasts/ G.V. Galevskii, V.V. Rudneva, E.K. Yurkova // Russian Journal of Non-Ferrous Metals – 2007. V. 48. – №2. – P. 157-160.
- [2] Plasma Chem [Electronic resource] /Nano Powders; Webmaster PIXXL.WEBDESIGN.– Electronic data. – Berlin: Plasma Chem GmbH, [2008]. – URL: www.plasmachem.com
- [3] NEOMAT NANO POWDERS [Electronic resource]/ Products. – Electronic data. – Salaspils: Neomat Co., [2008]. – URL: www.neomat.lv
- [4] Nanoceramics Powders [Electronic resource]/ Hefei Kaier Nanotechnology & Development Ltd. Co. – Electronic data. – Hefei Kaier Nanotechnology & Development htd. Co., [2008]. – URL: www.hfkiln.com
- [5] NanoAmor. Nanostructured & Amorphous Materials. Inc. [Electronic resource]/ Products.– Electronic data. – Huston: Nanostructured &Amorphous Materials. Inc., [2008]. – URL: www.nanoamor.com
- [6] Rudneva V V Thermal characteristics of three – jet plasma reactor / V.V. Rudneva, G.V. Galevskii, E.K. Yurkova// Steel in Translation. – 2007. Vol. 37. – No. 2. – P.115–118.
- [7] Nozdrin I V Reactor for plasmometallurgical production of refractory borides and carbides / I.V. Nozdrin, L. S. Shiryayeva, G. V. Galevskii, V. V. Rudneva// Steel in Translation. – 2011. Vol. 41. – No. 8. – P. 644–648.
- [8] Nozdrin I V Particle size of vanadium and chromium borides and carbides in a plasma flux / I.V. Nozdrin, G. V. Galevskii, L. S. Shiryayeva, M.A. Terenteva// Steel in Translation. – 2011. Vol. 41. – No. 10. – P. 799-801.
- [9] Nozdrin I V Plasma synthesis and physicochemical certification of chromium nanoboride / I.V. Nozdrin, L. S. Shiryayeva, V. V. Rudneva// Steel in Translation. – 2012. Vol. 42. – No. 12. – P. 797-801
- [10] Efimova K A Synthesis and properties of nano-scale titanium boride // K.A. Efimova, G. V. Galevskii, V. V. Rudneva//IOP Conf. Series: Materials Science and Engineering – 2015. Vol.91
- [11] Garbuzova A K Titanium Carbide: Nanotechnology, Properties, Application / IOP Conf. Series: Materials Science and Engineering – 2015. Vol.91
- [12] Rudneva V V Investigation of the morphology and particle size of silicon carbide nanopowders using electron microscopy/ V.V. Rudneva , G.V. Galevskii, E.K. Yurkova // Russian Journal of Non-Ferrous Metals – 2010. T. 51. – №2. – P. 158-164.
- [13] Kuznetsov M A, Zernin E A, Danilov V I, Kolmogorov D E, Zoubenko L N Corrosion and mechanical properties of austenitic steel weld joints. // IOP Conference Series: Materials Science and Engineering. – 2015. – №91 – <http://iopscience.iop.org/article/10.1088/1757-899X/91/1/012010/pdf>.
- [14] Kuznetsov M A, Barannikova S A, Zernin E A, Filonov A V, Kartsev D S Methods for defining the concentration of nanostructured powders in protective gas and its effect on the micro-

- structure of deposit metal // Applied Mechanics and Materials. - 2015 - Vol. 770. - p. 28-33.
- [15] Kuznetsov M A, Zernin E A, Lukashov A S, Zhuravkov S P Influence of Molybdenum Nanopowder Concentration on Welded Joint Microstructure // Applied Mechanics and Materials. - 2014 - Vol. 682. - p. 438-442.