

Principles of construction of ultrasonic tomographs for solution of problems of nondestructive testing in mechanical engineering

I Bolotina¹, A Bulavinov², R Pinchuk² and Y Salchak³

¹ Industrial and Medical Electronics Department, Tomsk Polytechnic University, 30, Lenina ave., Tomsk, 634050, Russia

² GmbH 'I-Deal Technologies', 2, Science Pk, Saarbruecken, 66123, Germany

³ International Scientific Educational Laboratory of Nondestructive Testing, Tomsk Polytechnic University, 30, Lenina ave., Tomsk, 634050, Russia

E-mail: bolotina@tpu.ru

Abstract. The paper considers the problems of ultrasonic nondestructive testing of products intended for mechanical engineering. The functional and electronic circuits of an ultrasonic tomograph are presented. The function of signal radiation from the clocked multielement apparatus is described, the cross-functional flowchart of the prototype of a US tomograph is considered. The development trends of ultrasonic tomography for near-term outlook are demonstrated.

1. Introduction

The risk assessment of the failure of the loaded systems in mechanical engineering is based on precise data on the loading, parameters of the material and possible locations of defects, resulting from manufacturing or operation. Manufacturing of equipment, elements, articles and pieces of equipment, the damage of which is of high risk to people and environment, or can lead to considerable financial losses, should undergo inspection of the presence of possible defects. Therefore, an ultrasonic pulse-echo inspection (USI) has become obligatory for welding joints experiencing excessive pressure, for structural materials used in aircraft industry and etc. The USI advantage is that this method possesses perfect identifiability of flat defects, such as incomplete fusion (welding defect), delamination and cracks in the production volume or in the hard-to-rich areas. Other reasons in favour of USI application are a relatively simple configuration, a possibility of control automation, absence of environmental requirements.

Nevertheless, USI results still present only qualitative information on the presence of the reflectors, the analysis of which was conducted by comparing it with data of the typical reflectors, such as notches, lateral apertures or punts. Thus, standard inspection procedures do not allow quantitative evaluation of the results and identification of the type and parameters of defect.

Consequently, there is an actual necessity of development of an ultrasonic method and monitoring equipment with high resolution and contrast sensitivity to visualize reflectors, which will allow proper evaluation of the type and geometry of defect, and will meet the requirements of the regulatory documents in force and market requirements.



A new technology of US inspection based on application of antenna arrays differs from a traditional one by four features: a way of viewing of space inside the object under inspection and the way of reflection of the inner structure of the material of this object. One more difference is presentation of the inspection results to the operator in the form of images of the inner structure of the material of the object under control. Three-dimensional images, besides the convenience of perception by the operator of the inspection result, which is completely adequate to the actual location of boundaries and discontinuities of the material, allow in many cases measuring actual rather than equivalent sizes of discontinuities.

2. A functional circuit of a US tomograph

All known tomographs (technical and medical ones) are virtually constructed according to a single-type functional diagram (Figure 1) and represent a multichannel flow detector having M independent channels. In each of the channels there is a programmable delay line and a separate probe pulse generator. In a receiving part of each channel there is a preamplifier, an analog-to-digital converter and a digital programmable delay line. The outputs of all reception channels are combined in the summator, at the output of which there is a signal corresponding to the present angle of incident (in digital form).

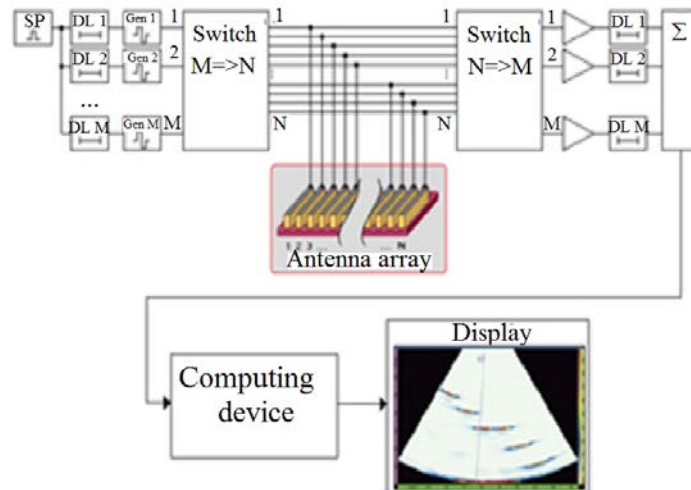

Figure 1. A functional circuit of an ultrasonic tomography.

As the number of array elements generally exceeds the number of tomograph's channels ($N > M$), the generators' outputs and the receivers' inputs are connected to the elements of the antenna array (AA) through multichannel switches intended for connecting of the required group of antenna elements to the apparatus channels. All electronic circuitries are usually located in the apparatus' case, but the array is connected to it by a multiconductor cable.

The summator output is connected to a computing device, which provides transformation of coordinate systems (from polar into Cartesian) to adequately represent a cross-section image on the display screen. Besides, it implements an operational control over the delay lines and other units of the tomograph.

The most important part of the tomograph is an antenna array (AA). Its properties in many respects define the quality of the cross-section under reconstruction, expressed in terms of noise levels, the extension of the dead space, spurious suppression and others. The development of the construction and adjustment of the manufacturing technique of these devices are a time consuming and expensive procedure demanding special equipment, materials, design decisions and deep understanding of physics of formation and spreading of ultrasonic (US) oscillations.

The main parameters of the array are the mode of the formed oscillations (longitudinal, transversal or multimode ones), frequency characteristics (band frequency, transmission bandwidth, pulse shape)

and design parameters (the number and the size of the elements, the width and the length of the antenna aperture) [1].

In order to create a multichannel system it is possible to specify three basic functions performed by it: radiation of a US signal, its reception and image reconstruction (Figure 2).

The first functional group (radiation and reception) is realised by means of digital ultrasonic electronics. Standard components, such as a delay of the signal radiation, preamplification, an analog-digital converter (ADC) are preliminary distinguished as separate functional modules. The system, performing the necessary functions, such as analog filtration, a module of averaging and an interface for communication with a computer, can serve as a prototype of the system for US tomography. Different types of reconstruction, image and signal processing can be additionally realised by means of the software.

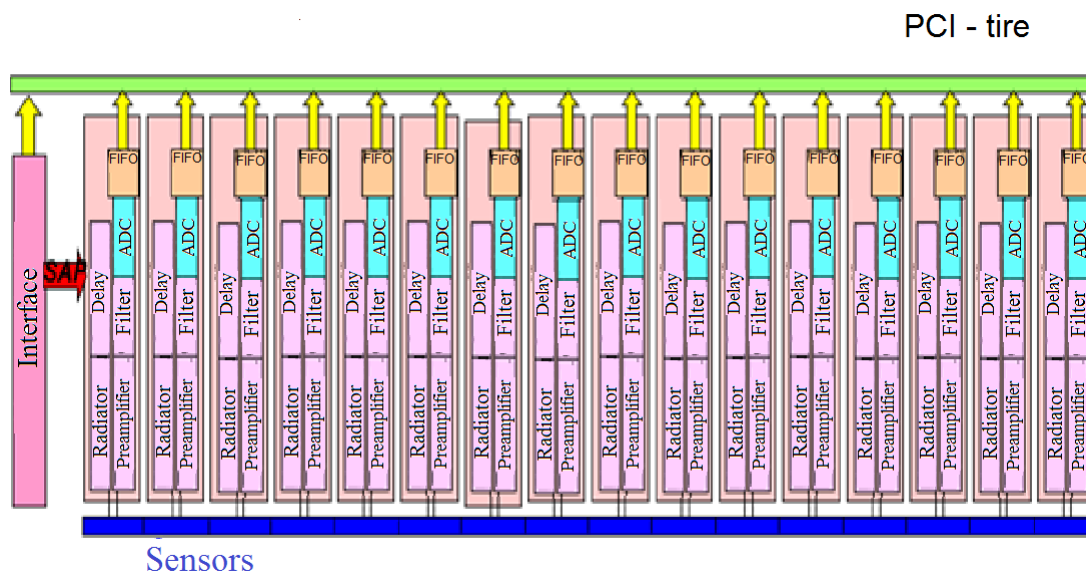

Figure 2. An electronic circuit of the system of US tomography.

3. The function of the signal radiation from the clocked multielement apparatus

From the standpoint of electronics, the function of signal radiation is not connected with the function of reception. The information about the object can be received in an arbitrary sequence, then it is summed and represented in the form of a single ultrasonic signal. In this case the radiating elements of the multielement apparatus are adjusted so that at a definite point of time only one radiator is active, while the rest operate in the reception mode.

Such approach has a number of diagnostic advantages, such as, for example, an opportunity to vary the aperture of each element, thus influencing the resolution capability and allowing adjustment of the sensitivity of the whole system. In case of a smaller aperture of the unit element of the apparatus, it is possible to obtain a higher resolution. In classic multielement apparatuses, the directional radiation pattern of the US signal is determined by means of corresponding time shifts. A wide directional pattern of one of the array elements can be actually useful for obtaining wide radiation angles. If the distance between the elements is less than the length of a half-wave, the directional pattern will not have any peaks, which are necessary for focusing in a definite control area. Therefore, in practice the work is conducted using limited rotation angles of the radiators, which is achieved by applying the radiators with a narrow aperture (Figure 3) [2].

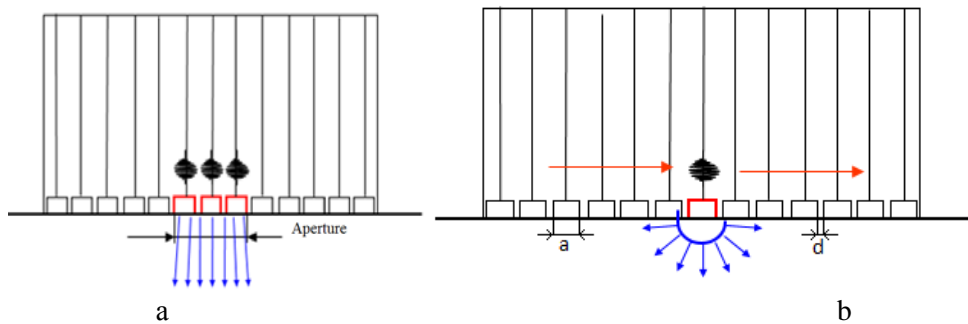

Figure 3. A variation of the radiation aperture: *a* – the front of acoustic radiation from the element having a wide aperture; *b* – focused acoustic radiation from the elements with a narrow aperture.

In case of clocked faceted arrays, it is possible to vary both the size of the element (a) and the distance between the elements (d) (Figure 3a).

If d and a have large values, it is possible to conduct the analysis faster and with higher sensitivity, but with lower resolution capability. Conversely, if d and a have low values, it is possible to obtain an improved resolution capability. Due to such flexibility it is possible to realise different analysis strategies, for example, quick scanning of a poor quality, and then slow examination of the dangerous areas using high resolution.

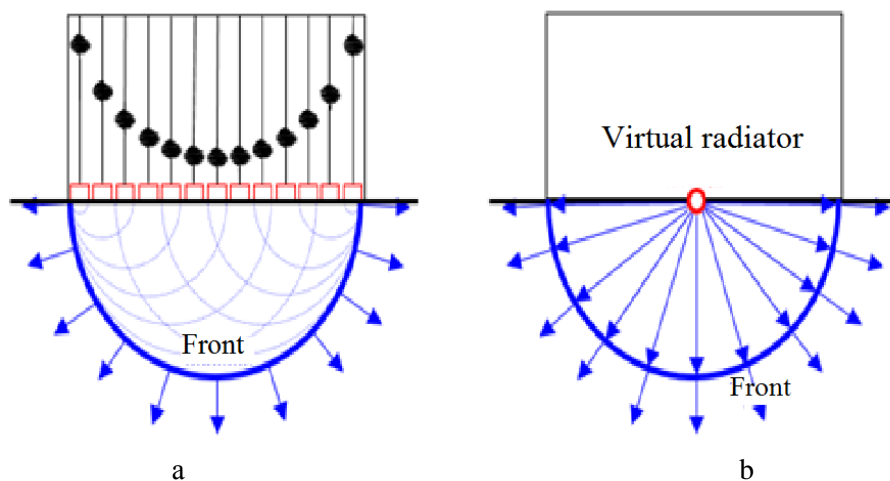

Figure 4. Defocused radiation: *a* – created by means of the group of radiators; *b* – created by means of a unit radiator of high power.

A defocused impulse provides still greater opportunities (Figure 4) [3]. All elements of the array operate in the radiator mode in the same time. It is necessary to select such distance between the elements that would allow the wave front to assume the shape of the sphere surface (Figure 4a). In this case, this group can be considered as a unit radiator of higher power (Figure 4b).

Let us formulate the following advantages of such approach:

- High speed of control. Per one time, it is possible to radiate in all directions;
- The uniform energy distribution over the half space and, thus, uniform sensitivity is obtained independently of the radiation angle;
- A higher sensitivity in comparison to the alternating impulse radiation by the elements.

A part of the processing of the received signal occurs directly in each of the channels of the digital electronic device. It includes amplification of the received signal, analog filtration, analog-digital conversion, averaging and adjustment of the depth. It is necessary to digitize the received ultrasonic signal using corresponding frequency.

Figure 5 represents a cross-functional flowchart of the multielement system. As it was mentioned above, an acoustic beam is controlled independently when sending and receiving a signal. The pulse delay in each of the channels has the accuracy of about 1 ns. Source [4] considers the angle resolution in the following way:

$$\Delta\theta = \frac{\Delta\tau_{\min}[ns] \cdot N \cdot f[MHz]}{12000 \cdot \cos\theta} \quad (1)$$

When $\Delta\tau = 1$ ns, a number of elements are $N = 16$, and when the frequency of the analysis is $f = 5$ MHz, the angle amounts to $\Delta\theta = 0.4^\circ$. Hence, electronics meets one of the essential requirements for further reconstruction of a signal and an image.

A receiving electronic module is equipped with ADC, having the resolution beginning from 10 bits, taking into consideration a sign bit (the amplitude value is from -512 to $+512$). This corresponds to a dynamic area of 54 dB. Under a low ratio between the signal and the noise in separate channels and under digital stacking of the signals, this is an important parameter, influencing the image quality. Thus, the selected electronics provides all conditions for signal and image processing, conducted by the module of reconstruction (Figure 5).

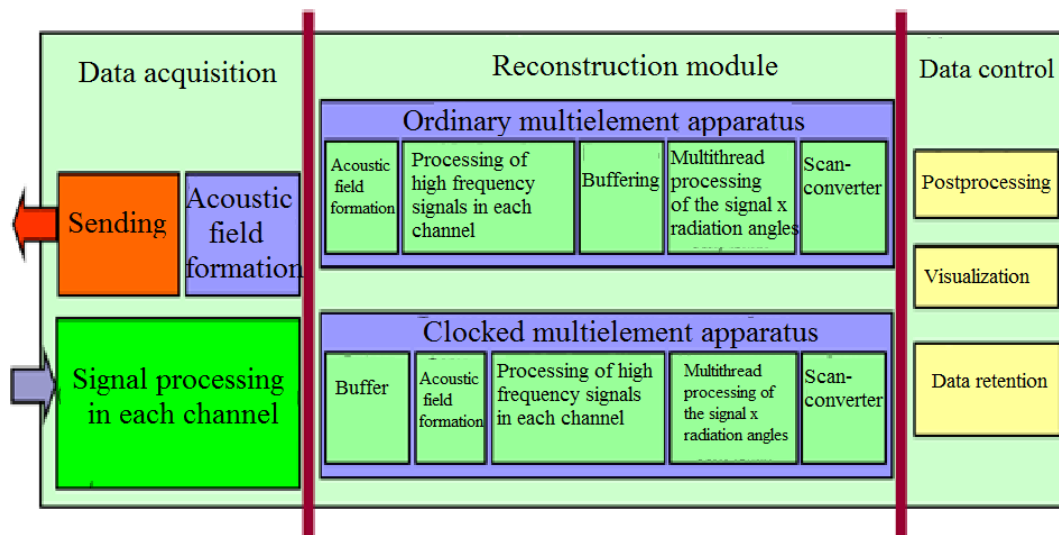

Figure 5. A cross-functional flowchart of the prototype.

In both cases the following functional groups – signal processing algorithms – will be applied:

a) Formation of the acoustic field.

Let us imply a reception as a coherent addition of the received unit signals of the array element, having a corresponding time delay for each radiation angle and focal depth. Unit ultrasonic signals can be projected on the temporal axis; at that, a synthetic focus is achieved in the summary, physically realizable near field. The result of beam formation, in case of using an ordinary multielement apparatus, will be a high-frequency signal for a given radiation angle and, correspondingly, a focal depth. In case of the clocked multielement apparatus, it is necessary to carry out several times of measurements. When applying the clocked multielement apparatus, it is possible to calculate several US signals in the specified angular range using the same data. In both cases (standard faceted arrays or clocked faceted arrays), one or several high frequency US signals are obtained.

b) Processing of high frequency signals of the multielement apparatus for each radiation angle.

The signals, obtained by coherent summation, can be subsequently subjected to processing. First of all, it is a question of filtration. For this purpose it is possible to apply many different methods, for example, Fourier filtration and others. In case of a poor signal/noise ratio, a signal can be averaged. Further, it is possible to logarithmically compact the dynamic field and to establish corresponding thresholds of registration.

c) Multiple-line processing of a signal for a specified angular domain.

It implies processing of several unit signals after coherent summation for a definite radiation angle:

- Automatic adjustment of amplification as a function of the angle to compensate the loss of sensitivity at wide angles;

- Interpolation between two neighbouring signals;

- A comparative analysis of the signals by their properties (an amplitude, a structure, a phase term).

d) A scan-converter.

A scan-converter is a very important module of signal processing. It converts linear ultrasonic signals into two- and three-dimensional images and vice versa, and also calculates two-dimensional projections (B-scan, C-scan, D-scan, TD-scan) from a three-dimensional image. The basis for 3D reconstruction is the use of 2D matrix arrays or a bias of the linear array perpendicular to the direction of rotation.

e) Postprocessing.

Postprocessing is used for the analysis of the signal and images. This implies the following:

- Representation of echo-amplitudes by colour or brightness;

- Adaptive contrast enhancement;

- Automatic recognition of the geometry of the measuring object (automatic search of boundaries).

The above-mentioned functions operate similarly for standard and clocked faceted arrays, independently of the field of application, be it nondestructive testing or medicine [5, 6]. The functional separation is important from the position of the modular composition of the system equipped with the faceted array, where each separate function or functional group is determined by a separate module.

4. Conclusions

The development of ultrasonic tomography for near-term outlook should proceed in the following directions [7]:

- Improvement of the design procedures of residual life, taking into account the parameters of actual defects for resource management. A great number of industrially dangerous objects, subjected to inspection according to a new technology, offer a prospect of creation of a wide range of design procedures of residual life with the aim of managing the resource of these objects.
- Establishment of standards for evaluation of the actual defects for the objects, being in service. On the basis of lifelength of design procedures of residual life it is possible to establish operating standards of the object quality evaluation.
- Provision of defects measurement and residual life calculation in unified combination with the issue of inspection results in the form of operating life immediately after conducting the inspection.
- Creation of measuring equipment with high performance, serviceability and unification of pieces of equipment. It is necessary to develop of a great number of scanning devices, which would provide the inspection of the whole nomenclature of the objects.
- Integration of search and measuring modes into a unique entire measuring mode. Although, in this case, the amount of incoming data significantly increases, the inspection quality will jump sharply owing to improved reliability, especially because the modern machinery develops rapidly and does not create any obstacles for realisation of this mode.
- Automation of processing operations, analysis and documenting of the results. Automation will lower manning requirements and raise the inspection efficiency sharply.

Acknowledgments

The study was financially supported by the Ministry of Education and Science of the Russian Federation within the Federal Target Program entitled 'R&D in Priority Areas of Development of Russia's Scientific and Technological Complex for 2014–2020' (unique project ID: RFMEFI57514X0048).

References

- [1] Alekhin S, Bishko A, Dureiko A, Zhukov A, Samokrutov A, Sokolov N and Shevaldykin V Available at: [http://acsvs.ru/article/7article id=21](http://acsvs.ru/article/7article%20id=21)
- [2] Bulavinov A, Kröning M, Pinchuk R and Reddy K 2009 *Echtzeit-3D-Bildgebung mittels der getakteten Gruppenstrahlertechnik für Ultraschallprüfanwendungen* (Münster: DGZfP)
- [3] Nihei K, Nakagawa S, Myer L and Majer E 2002 *Fracture Imaging with Elastic Waves* (Canada: 5th Internat. Workshop on the Applic. of Geophysics in Rock Engineer.) pp 20–24
- [4] Schmitz V, Langenberg K, Chakhlov S 2003 *Berechnung hochfrequenter Signale für eine automatische Ultraschallprüfung und Transversalwelleneinschallung mit einem auf der Kirchhoffschen Näherung beruhenden Ray Tracing Verfahren* (Mainz: DGZfP)
- [5] Bolotina I, Kryoning K, Kvasnikov K, Sednev D and Sumtsova O 2014 *Advanced Materials Research* **1040** 959–964
- [6] Ploskov N, Danilov V, Zuev L, Zavodchikov A, Bolotina I and Orlova D 2012 *Journal of Applied Mechanics and Technical Physics* **53**(4) 611–615
- [7] Vopilkin A 2009 *Control. Diagnostics* **4** 37–47