

# Investigations and Non-destructive Testing in New Building Design

V Klimenov<sup>1,2</sup>, A Ovchinnikov<sup>3</sup>, S Osipov<sup>4</sup>, A Shtein<sup>5</sup>, A Ustinov<sup>3</sup> and A Danilson<sup>3</sup>

<sup>1</sup>Professor, NDT Institute, Tomsk Polytechnic University, Russia

<sup>2</sup>Professor, Tomsk State University of Architecture and Buildings, Russia

<sup>3</sup>Research Assiatnt, Tomsk State University of Architecture and Buildings, Russia

<sup>4</sup>Leading Reseacher, NDT Institute, Tomsk Polytechnic University, Russia

<sup>5</sup>Engineer, NDT Institute, Tomsk Polytechnic University, Russia

E-mail: nauka@tsuab.ru

**Abstract.** Mechanical rebar couplers are preferable in the advanced building construction and structural design of antiseismic elements. The paper presents destructive inspection techniques used to investigate stress fields (tensile and compressive) and deformation curves for mechanical rebar splicing. The properties of mechanical rebar splicing are investigated by the non-destructive testing digital radiography. The behavior of real connections (column-to-column, beam-to-column) is studied under static and dynamic loads. Investigation results allow the elaboration of recommendations on their application in the universal prefabricated antiseismic structural system developed at Tomsk State University of Architecture and Building, Tomsk, Russia.

## 1. Introduction

In building design and construction, the longitudinal connection of reinforcing bars is often needed since their length is restricted by the transportation conditions and should not exceed 12 m. In Russia, welded and lap splices are widely used. Welded splice has a number of disadvantages connected with electricity costs, attraction of qualified specialists, and labour intensity. Another type of rebar connection is lap splice that also has disadvantages lying in rebar overrun due to overlaps and installation of additional shear reinforcement in rebar connections [1–4]. In Russia, mechanical rebar splicing is used in in-situ concrete and prefabricated reinforced concrete. However, the increased requirements for the operational safety and earthquake resistance of building constructions as well as lowering costs of building and construction works pose the problem of connecting construction members with prefabricated reinforced concrete [5]. A series of experiments was carried out to solve this problem including the detection of the stress and strain state of rebar joints under compression and tension, measured connections between the reinforced concrete members of the universal prefabricated antiseismic structural system under static and dynamic loads.

The main quality parameter of mechanical rebar splicing is its strength uniformity. The strength uniformity condition is satisfied when the fracture load induces the fracture by rebar clear opening rather than by a coupler. Since the real rebar connections are exposed to different loads, the laboratory investigations included the tensile and compressive tests for rebar splicing and static and dynamic load tests for rebar fragments.

Unlike the welded splice which requires a complete weld inspection, the mechanical rebar splice allows it at a stage of the elaboration of technology or by selected node connections. At the same time,



in building constructions of the high responsibility level, the rebar splice inspection can be carried out only by non-destructive testing (NDT) digital radiography [6, 7].

NDT digital radiography of the mechanical rebar splice allows not only to estimate the strength properties of these connections but also to forecast their functional performance including, for example, seismic loads.

## 2. Materials and metho

The schematic view of reinforcing bars spliced with a crimping coupler system designed to withstand tensile and compressive loads, is presented in figure 1. Hot-finished weldless tubes of the type C20E2C steel are used in the capacity of mechanical couplers for rebar splicing. The outer and inner diameters of the tubes are 51 and 32 mm, respectively. These tubes are manufactured in accordance with the Construction Standards and Regulations of the Russian Federation. This type of rebar connection is designed for the repeated load applications. The load tests of this rebar connection can result in the failure of both the rebar section and the coupler. Rebar was spliced on the rebar coupler crimping machine PA-80 with the operating pressure of 800 atm. Figure 2 demonstrates mechanical rebar splice performed by the coupler after its crimping.

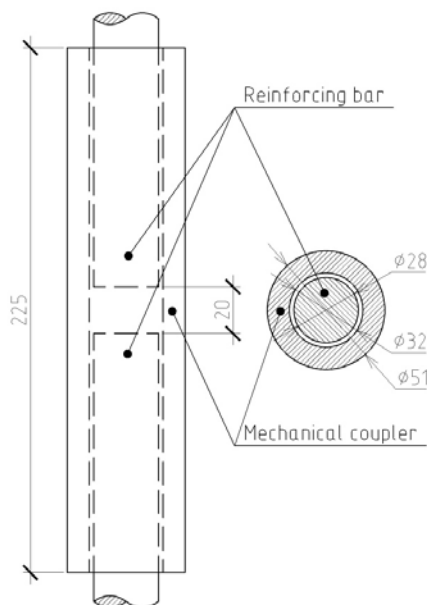

**Figure 1.** Schematic view of reinforcing bars spliced with a crimping coupler system designed to withstand tensile and compressive loads.



**Figure 2.** Photograph of mechanical rebar splice.

Vic-3D digital image correlation system allows detecting deformation fields on the specimen surface. Figure 3 contains the photographs of compressive and tensile load tests on the Universal Testing Machine 4500. Such parameters as the surface geometry, displacements, relative deformations ( $\epsilon_{xx}$  and  $\epsilon_{yy}$  by  $X$  and  $Y$  axes respectively and the main relative displacement  $\epsilon_1$ ), displacement and deformation ratios, and surface curvature were determined.



**Figure 3.** Photographs of load tests: *a* – tensile load test on Tensile Testing Machine MR-500; *b* – compressive load test on the Universal Testing Machine 4500.

The strength characteristics of mechanical rebar splicing were tested both in tension and compression. Tensile tests were carried out on 500 kN Tensile Testing Machine MR-500 (Russia) as shown in figure 3a. The maximum achieved loading rate was 1 kN/s.

Compressive tests were carried out on 4500 kN Universal Testing Machine 4500 (USA) as shown in figure 3b. The maximum achieved loading rate was 1 N/mm<sup>2</sup> per second.

### 3. Tensile test results

The tensile deformation curve of rebar splice coupler is presented in figure 4. The analysis of this curve shows that elastic deformations of rebar coupler are developed within the load range from 0 to 235 kN. At 185 kN tensile force, the stress experienced in the section of reinforcing bar is 300 MPa that corresponds to 0.6  $\sigma_{0.2}$ . At this stress value, the plastic deformation in the coupler equals to zero. Figure 5 shows the tensile deformation of rebar coupler.

Tensile tests of the mechanical rebar splicing show that its fracture occurs at the yield strength of rebar with the formation of a neck that indicates to the rebar transition to plastic deformation. The value of deformability of the rebar coupler equaled to  $2.48 \cdot 10^{-9}$  m/N, is detected at the conventional yield strength of 500 MPa achieved by the reinforcing bar.

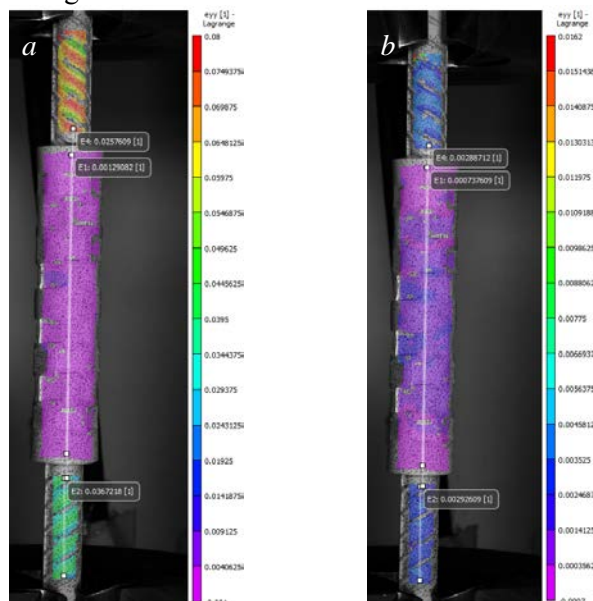
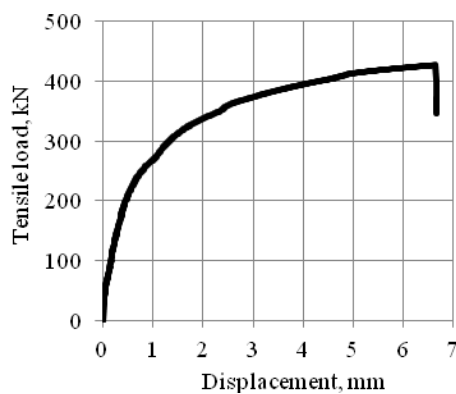
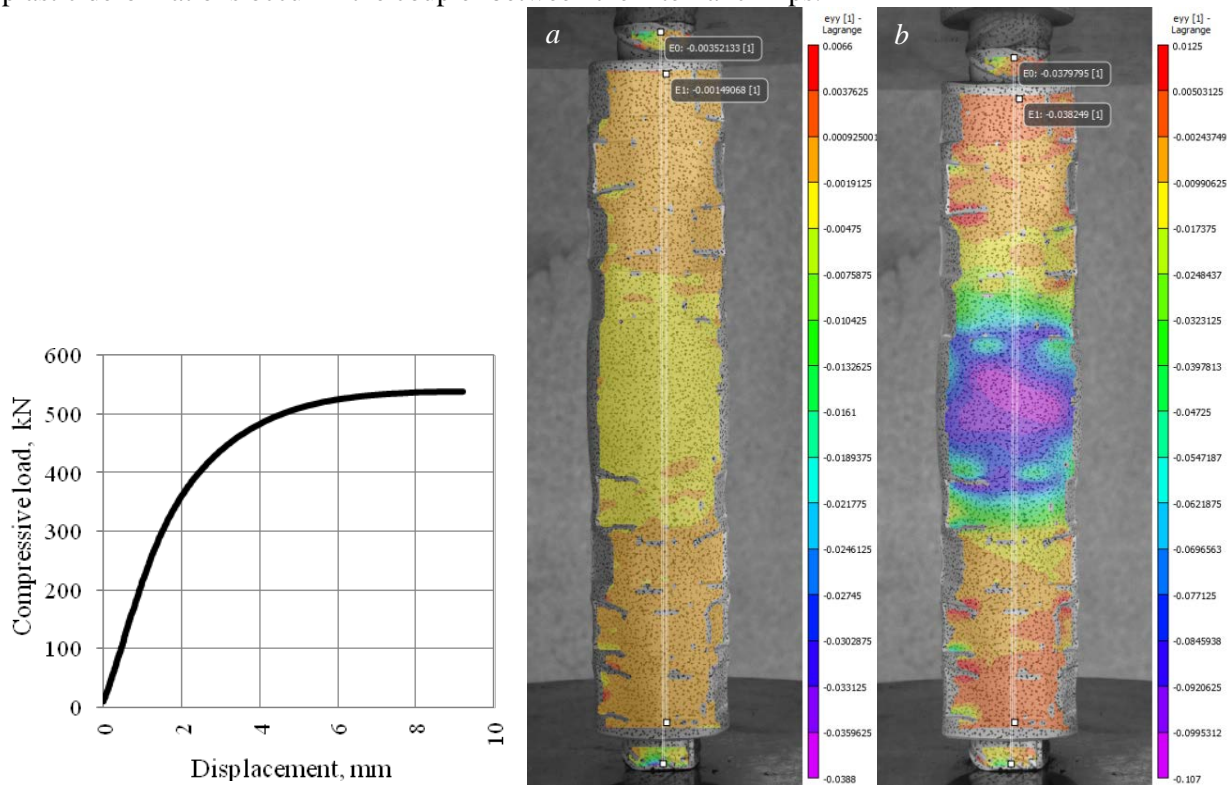

**Figure 4.** Deformation curve of rebar coupler. **Figure 5.** Surface deformation of rebar coupler: *a* – elastic deformation; *b* – inelastic deformation.

#### 4. Compressive test results

The compressive deformation curve of the rebar coupler is given in figure 6. The analysis of this curve shows that elastic deformations of the rebar coupler are developed within the load range from 0 to 320 kN. At 185 kN compressive force, the stress experienced in the section of reinforcing bar is 300 MPa that corresponds to  $0.6 \sigma_{0.2}$ . At this stress value, the plastic deformation in the coupler equals to zero.

The compressive deformation of the rebar coupler surface is shown in figure 7. The maximum plastic deformations occur in the coupler between the internal crimps.



**Figure 6.** Deformation curve of rebar coupler connection with 20 mm gap.

**Figure 7.** Surface deformation of rebar coupler: *a* – elastic deformation; *b* – inelastic deformation.

#### 5. Non-destructive testing of reinforcing bar connection

The development of the reinforcing bar connecting technology using the analyzed technique is impossible without the NDT methods [6]. Due to the properties of test object, the only method that can be used for its investigation is the radiation method [7, 9]. The recent development of digital radiography [8] characterized by the relative simplicity and expressiveness, allows imaging by the Remote RadEye200 detector module with  $1024 \times 1000$  pixel image area with  $96 \mu\text{m}$  pixel size. Radioisotopes, X-ray generators and betatrons can serve as the sources of photon radiation. A possibility of the flaw detection analysis is assessed by radiographic images generated for the two test objects, namely rebar fragments. These images are obtained by the digital radiographic system with the maximum photon energy of 160 keV delivered by the X-ray source. In order to reduce the low-energy photon generation, the photon flux is filtered by 2 and 4 mm thick copper plates. Since the maximum photon energy used in this experiment, is far from the optimum, the resulting radiographic image is obtained by averaging 16 images to enhance the signal-to-noise ratio. Rebar locates at the maximum distance from the detector array, therefore, the geometric enhancement is insignificant. The optimum pixel size comes to  $88\text{--}90 \mu\text{m}$ .

Figure 8 presents the shadow radiographic images of reinforcing bars connected by the mechanical couplers having the outer diameters of 47 and 51 mm respectively. The analysis of these images allows making a number of conclusions concerning the parameter assessment of tested rebar connections.

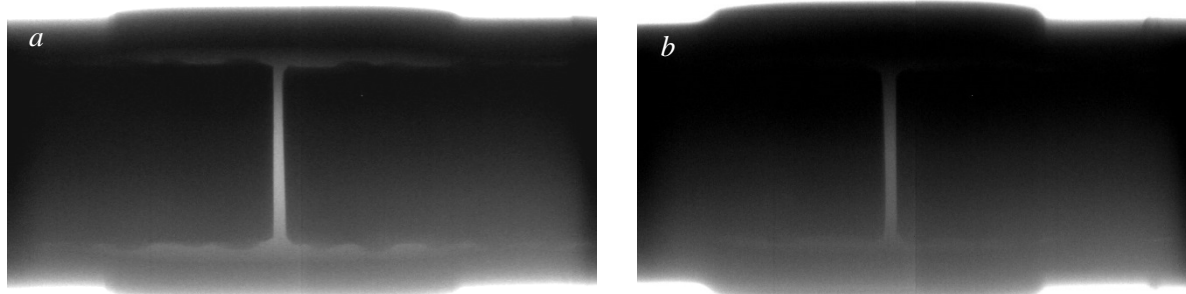

**Figure 8.** Radiographic images of reinforcing bar connected by the coupler with outer diameter:  
*a* – 47 mm; *b* – 51 mm.

1. A distance between the two rebar fragments connected by mechanical couplers can be measured with high accuracy (not less than 0,1 mm). In figure 8*a*, this distance varies between 0,704 and 1,6 mm, while in figure 8*b* it varies between 1,6 and 2,05 mm.

2. The face plane rebar deviations from each other can be measured with pixel accuracy, and, accounting for the boundary effects, with sub-pixel accuracy.

3. Light spots observed on the contact boundaries between rebar fragments and mechanical couplers indicate to the low-quality connection. Light spots in figure 8*a* are quite visible, while in figure 8*b*, the light stripe within the contact boundary is faintly visible only on the one side of the image.

4. The additional geometric parameters of the rebar splice can be estimated, such, for example, as the finite length of mechanical coupler and its section.

It is worth noting that the flow detection analysis of the reinforcing bar connection should be supported by the appropriate technical standard documentation. Otherwise, this documentation should be elaborated and contain radiographic images of mechanical rebar splicing compared with their mechanical test results.

## 6. Experimental

Static load tests of node connections in the universal prefabricated antiseismic structural system developed at Tomsk State University of Architecture and Building (TSUAB), Tomsk, Russia, were carried out in accordance with the Construction Standards and Regulations of the Russian Federation and the test program developed at the Department of Reinforced Concrete and Masonry Structures, TSUAB.

The load test of the beam-to-column connection is conducted stage-by-stage, in equal amounts, at 10% of the fracture load to determine such parameters of node connections as strength, stiffness, and crack resistance. A 10 min interval is selected for the stress relaxation in node connections, while for the determination of the abovementioned parameters a 30 min interval is selected.



**Figure 9.** General view of beam-to-column connection: *a* – mechanical coupler; *b* – static load test.

Strength, stiffness, and crack resistance tests [10] of the beam-to-column connection assembled according to the universal prefabricated antiseismic structural system show that the rebar mechanical splice provided by the crimping coupler system is quite reliable for the node connection.

## 7. Conclusions

1. The suggested mechanical rebar splicing demonstrated its reliability providing the failure outside of the joint along the rebar cross-section rather than by the coupler.
2. The X-ray investigation allowed checking the assembly quality of the suggested mechanical rebar splicing using non-destructive testing that considerably simplifies the procedure of the quality control.
3. Mechanical couplers used in building constructions provide the reliable rebar connections allowing to design and build antiseismic structures in hazardous regions exposed to both static and dynamic loads.

## Acknowledgements

The authors acknowledge the financial support from the Ministry of Education and Science of the Russian Federation (Agreement N 02.G25/31/0022) and the Russian Foundation for Basic Research (Project N 13-08-98027). Thanks also go to Margaret Vorobyeva, translator TSUAB. This work was carried out within the Governmental Decree N 218.

## References

- [1] Madatyán S A and D'yachkov V V (2007) *Beton i zhelezobeton* **4** 16–20
- [2] Matkov N G, Balyuchik E A, Gubin V I, Rudenko A E and Uljutinov A V (2003) *Beton i zhelezobeton*. **4** 6–10
- [3] D'yachkov V V 2009 *Properties and use of mechanical couplers for reinforcing bars* (Moscow: Stroitel'stvo)
- [4] D'yachkov V V (2006) *Beton i zhelezobeton*. **1** 11–14
- [5] Guidance documents of operating organization N 0657-2006 Regulations for rebar mechanical connections in building and nuclear plant constructions
- [6] Einav I, Artem'ev B, Azizova E and Azizova A 2012 *Non-destructive testing in construction Teaching aid* (Moscow: Spektr)
- [7] SNiP 17625-83 1983 *Reinforced concrete structures and products. Radiation method of detection of concrete layer thickness and rebar size and arrangement*
- [8] Alkhimov Yu V, Shtein A M, Kas'yanov S V, Babikov S A, Batranin A V and Osipov S P (2013) *Testing. Diagnostics* **13** 31–42
- [9] Shtein A M, Cheprasov A I, Klimentov V A, Knyazev S V, Chakhlov S V and Belkin D S (2013) *Russian Physics Journal* **56**(1-2) 267–270
- [10] Hadi M N S and Tran T M (2015) *Materials and Structures* 19