

Available online at www.sciencedirect.com
ScienceDirect

Procedia CIRP 23 (2014) 155 – 160

www.elsevier.com/locate/procedia

Conference on Assembly Technologies and Systems

Disassembly of Electric Vehicle Batteries Using the Example of the Audi Q5 Hybrid System

 Kathrin Wegener^a, Stefan Andrew^{b*}, Annika Raatz^c, Klaus Dröder^a, Christoph Herrmann^b
^a*Institute of Machine Tools and Production Technologies, Production Technologies and Process Automation, Technische Universität Braunschweig, Langer Kamp 19b, 38106 Braunschweig, Germany*
^b*Institute of Machine Tools and Production Technologies, Sustainable Manufacturing and Life Cycle Engineering, Technische Universität Braunschweig, Langer Kamp 19b, 38106 Braunschweig, Germany*
^c*Institute of Assembly Technology, Leibniz Universität Hannover, An der Universität 2, 30823 Garbsen, Germany*

 * Corresponding author. Tel.: +49-531-391-7689; fax: +49-531-391-5842. E-mail address: s.andrew@tu-braunschweig.de

Abstract

The rising number of electric vehicles comes along with an increasing demand for Li-Ion batteries. As resources such as lithium are valuable it is economically worthwhile to recycle EV batteries. One of the first steps of every battery recycling process is the disassembly, which can be a quite time and cost consuming process and hence has to be planned properly. Using the battery of the hybrid car Audi Q5 as a case study, a planning approach for the disassembly will be discussed in this paper. Therefore, disassembly sequences will be derived from a priority matrix and a disassembly graph will be drawn up. Finally, recommendations for the design of the disassembly system and work stations will be given.

© 2014 The Authors. Published by Elsevier B.V. This is an open access article under the CC BY-NC-ND license

 (<http://creativecommons.org/licenses/by-nc-nd/3.0/>).

 Selection and peer-review under responsibility of the International Scientific Committee of 5th CATS 2014 in the person of the Conference Chair Prof. Dr. Matthias Putz matthias.putz@iwu.fraunhofer.de

"Keywords: disassembly; planning approach; electric vehicles; recycling; traction batteries"

1. Introduction

Due to climate change and the associated climate policy of the European Union the number of electric vehicles (EVs) in European road traffic is currently increasing and it is supposed to further increase for the medium-to-long term. For example the German government is aimed at having more than one million EVs by the year 2020 and even more than six million EVs by the year 2030 on German roads [1]. However, an increasing number of EVs also means an increasing number of high voltage (HV) batteries in use and hence an increasing number of end-of-life HV batteries. Most of these batteries are lithium-ion batteries which contain valuable materials like lithium and copper. Therefore, the recycling of such batteries could be economically reasonable as already proposed in the German project "LithoRec – Recycling of

Lithium-Ion Batteries" [2]. In the follow-up project "LithoRec II" it is planned to realize a recycling process on a pilot scale [3]. The process chain of the planned recycling process is depicted in Fig. 1. The first step of the recycling process is the discharge of the batteries in order to reduce the potential danger that comes along with the high voltage (up to 400 V) of the batteries. After the discharge the batteries are disassembled before they are subject to a coarse shredding. Subsequently, the shredded material is separated of which one part is treated or recycled and the other part is subject to a fine crushing. After the fine crushing the materials are separated once more before they are also treated or recycled. The objective of the project by realizing this process is to gain secondary raw materials that can be used for the production of new batteries or other industrial products.

The focus of this paper will be on the second step of the aforementioned process chain: the disassembly. For the disassembly of complex products, a well-established research topic, a number of planning approaches have been developed. Eversheim, Hartmann and Linnhoff give a comprehensive overview on this topic [4]. The planning approaches focus either on the planning of the whole disassembly system, i.e. the organization of the disassembly or the logistics such as [5], [6], [7], [8] and [9] or on the planning and control of disassembly sequences, such as [10], [11], [12], [13] and [14]. Other research activities concentrate on the development, optimization and application of single elements for an automated disassembly [15], [16]. Ciupek presents a planning approach for a simulation based planning, with a high focus on the integration of automated disassembly processes [17].

The disassembly of lithium-ion battery systems from automotive applications is a complex and therefore time and cost consuming process due to a wide variety of the battery designs, flexible components like cables, and potential dangers caused by high voltage and the chemicals contained in the battery cells. All these factors have to be considered when planning the disassembly process(es) and appropriate work stations. The complexity of the disassembly process will be demonstrated in this paper by using the example of the battery system of the Audi Q5 Hybrid and the VW Jetta Hybrid, respectively. Therefore in Section 2 this battery system is presented. In Section 3 disassembly sequences for such a system are derived. The achieved results will be used to draw conclusions for the design of the battery system as well as for the design of a disassembly system and its work stations.

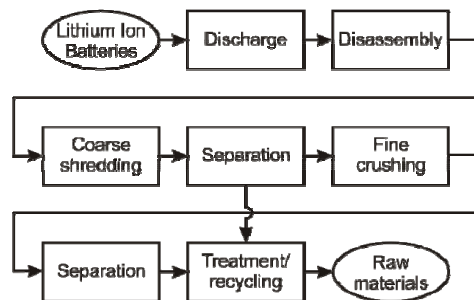

Fig. 1: Recycling process chain for lithium-ion battery modules/stacks as proposed in the project LithoRec II

2. The Audi Q5 Hybrid battery system

This section gives a brief overview of the structure of battery systems for traction applications. In a further step the examined battery system of the Audi Q5 Hybrid will be presented with its core specifications.

2.1. Structure of lithium-ion traction batteries

In general two different kinds of battery systems can be distinguished. On the one hand there are large battery systems

for full electric vehicles and on the other hand there are hybrid vehicle battery systems. Hybrid means in this context, that the vehicle is powered by an electric engine using the energy from the battery system, as well as powered by an internal combustion engine. The general construction of both types is similar.

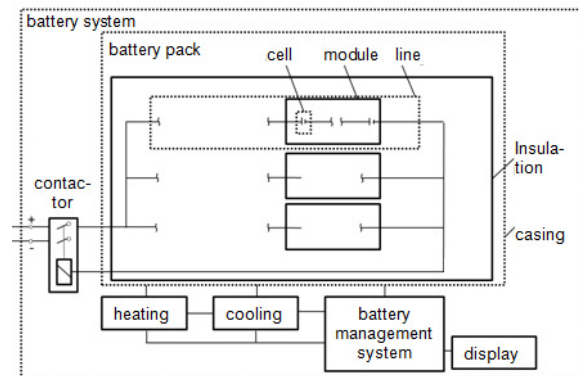

Fig. 2: General design of a traction battery system [18]

The battery cells are put together to modules/stacks and connected with conductors. These stacks are then connected to lines or directly to battery packs. Together with the components for heating/cooling, the battery management system and the display battery pack are placed in an insulated casing and forms together with the power electronics, the battery system. The schematic design of a battery system can also be seen in Fig. 2.

2.2. Specifications of the Audi Q5 Hybrid battery system

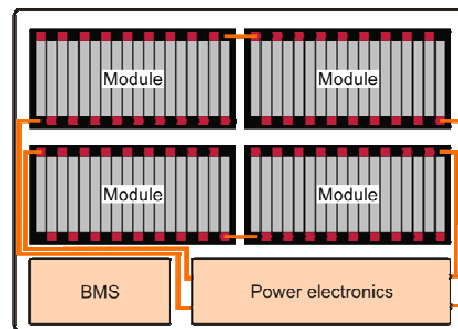

Fig. 3: Schematic set-up of the Audi Q5 Hybrid battery system

The Audi Q5 Hybrid battery system is built by the Audi AG within the Volkswagen Group. Therefore, an identically constructed battery system is used in the Volkswagen Jetta Hybrid. Fig. 3 shows schematically the set-up of the specific battery system. The Audi Q5 Hybrid system mainly comprises four battery modules, a battery management system (BMS) and the necessary power electronics. Overall, the Q5 system is dimensioned about 50 cm x 70 cm x 15 cm and weighs about 35 kg. The nominal capacity is 5Ah with a nominal voltage of

266 V. The four battery modules/stacks contain 18 battery cells each, which are connected in series. Each cell has a nominal voltage of 3.7 V. The main parts of the Audi Q5 Hybrid battery system are shown in Fig. 4 and Fig. 5, where the parts are labeled with a number later used for reference.

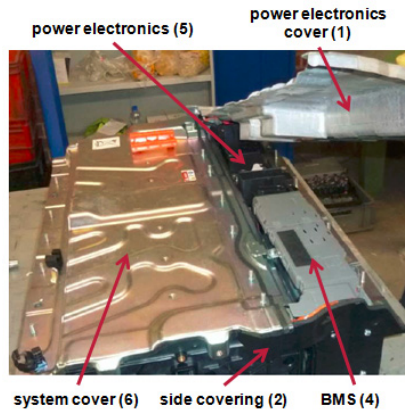

Fig. 4: Main components of the Audi Q5 Hybrid battery system (part I)

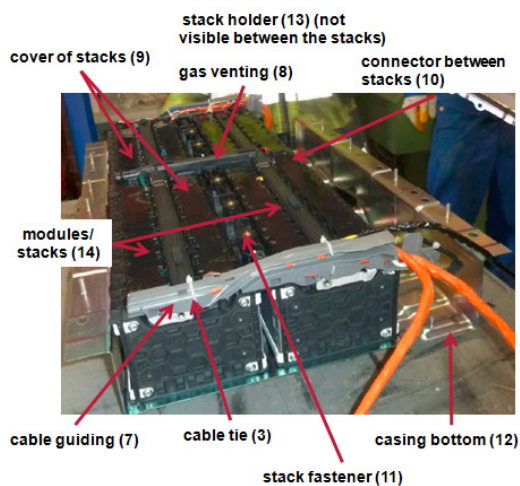

Fig. 5: Main components of the Audi Q5 Hybrid battery system (part II)

3. Disassembly analysis of the battery system

In this section the disassembly of the battery is described. The methodology for the analysis and structuring of the disassembly are briefly presented and subsequently directly applied to the example of the Audi Q5 Hybrid battery system. For the present study, a disassembly from the system level down to the module/stack level is considered. Looking at an industrial level of disassembling, it is neither economically feasible nor required from an environmental perspective to dismantle each and every part. Joint parts made from the same materials need not to be separated as they are supplied to the same material recycling process. The same applies to material mixtures that are separated in a downstream step

mechanically. The main aim of the disassembly in this paper is to obtain the modules/stacks from the battery system. The disassembly is carried out completely manually with the help of hand tools. The gained modules/stacks are then mechanically crushed in a two step shredding process and the various recyclable material fractions are procedurally separated and conditioned for further treatment and recycling steps.

In all the following descriptions the names and numbers are used according to Fig. 4 and Fig. 5, which are also shown in the following Table 1.

Table 1. Main parts to be dismantled in the Audi Q5 Hybrid battery system

Part number	Part name
1	power electronics cover
2	side covering
3	cable tie
4	battery management system (BMS)
5	power electronics
6	system cover
7	cable guiding
8	gas venting
9	cover of stacks
10	connector between stacks
11	stack fastener
12	casing bottom
13	stack holder
14	modules/stacks

3.1. Disassembly priority matrix

Once the parts have been identified it is necessary to consider the order of precedence of the disassembly steps. One measure to handle the precedence relations between the different parts is the disassembly matrix. In the disassembly matrix a one-to-one comparison of all parts with each other is carried out, assessing, which of the two parts needs to be disassembled first. The predecessor is assigned the number one. The successor part gets a minus one. If there is no precedence between the two parts, both parts are assigned with a zero. After every part is assessed against every other part, the sum for each part is calculated. For this matter only the positive ones are summed up to build a total. The higher this total figure is, the higher the rank in the disassembly system. For the disassembly matrix it is possible that several parts score the same rank, so that the disassembly matrix is not unambiguous.

For the Audi Q5 Hybrid battery system the disassembly matrix can be found in Fig. 6. Taking the example of the battery management system (BMS), which has the number 4, and the power electronics, number 5, it is shown that both have a '0' as it is indifferent which part has to be disassembled first. Assessing the BMS over the system cover,

number 6, it shows that the BMS is the predecessor of the system cover.

3.2. Analysis of the disassembly steps

In the next step, the necessary disassembly operations for the hybrid battery system need to be defined (see Table 1 with reference to Fig. 4 and Fig. 5). Then the necessary tools to carry out the disassembly steps can be assigned to the various operations. Keeping in mind that the main aim is to separate the battery modules/stacks for further processing the following 24 disassembly steps are necessary (Table 2). The numbers in brackets behind the parts in the second column are the according numbers from Table 1.

Priority matrix dismantling	Successor														Total	Rank
	1	2	3	4	5	6	7	8	9	10	11	12	13	14		
1 power electronics cover	1	1	1	1	1	1	1	1	1	1	1	1	1	1	13	1
2 side covering	-1	1	1	1	0	1	1	1	1	1	1	1	1	1	11	2
3 cable tie	1	1	1	1	1	1	1	0	1	0	1	1	1	1	9	3
4 BMS	-1	-1	-1	0	1	1	1	1	1	1	1	1	1	1	9	3
5 power electronics	-1	-1	-1	0	1	1	1	1	1	1	1	1	1	1	9	3
6 system cover	-1	0	-1	-1	1	1	1	1	1	1	1	1	1	1	8	8
7 cable guiding	-1	-1	-1	-1	-1	1	1	0	1	1	0	1	1	1	5	7
8 gas venting	-1	-1	-1	-1	-1	0	0	1	1	1	1	1	1	1	4	8
9 cover of stacks	1	1	0	1	1	1	0	0	0	0	1	1	1	1	3	9
10 connector between stacks	-1	-1	-1	0	-1	0	0	0	0	1	1	1	1	1	3	9
11 stack fastener	-1	-1	0	-1	0	-1	0	0	0	1	1	1	1	1	3	9
12 casing bottom	-1	-1	-1	-1	0	-1	-1	-1	-1	1	1	1	1	1	2	12
13 stack holder	1	1	1	1	0	1	1	1	1	1	1	1	1	1	1	13
14 modules/stacks	1	1	1	1	1	1	1	1	1	1	1	1	1	1	0	14

Fig. 6: Disassembly matrix

The overview over the disassembly processes shows that it is not necessary to use specialized tools. Only a small number of different tools needs to be used, although it must be considered, that the screws that need to be unscrewed have different measures and heads.

As a first step all visible screws on top and bottom side need to be undone. Then the cover of the power electronics can be removed. All removal processes are carried out by hand. To reduce the health risks for the disassembly worker it is necessary to check the state of charge of the battery system and if necessary to discharge the battery system. After removing the side coverings and the disassembly of the live lines from the modules, the cable ties can be cut and the plug connection between the cell controllers and the battery management system can be disassembled. In order to disassemble the main system cover, the battery management system and the power electronics need to be removed and the bus for the thermo sensors must be cut. In the next steps the

system cover, the cable guiding and the gas venting as well as the connectors between the modules/stacks can be disassembled and removed. After disassembling the stack holders, the battery pack can be taken out of the casing bottom. In a last step, the stack fasteners are unscrewed and removed to finally obtain the battery stacks/modules.

Table 2. Disassembly steps and necessary tools

Disassembly step number	Disassembly step	Necessary tool
I	Unscrew covers (1), (6) and casing bottom (12)	Screw driver
II	Removal of the power electronics cover (1)	Hand
III	Checking of the state of charge	Special measuring device
IV	Removal of the side covering (2)	Hand
V	Disassembly of the live lines from the modules/stacks (14)	Screw driver
VI	Cutting of the cable ties (3)	Side cutters
VII	Disassembly of the plug connection between the cell controllers and the BMS (4)	Hand
VIII	Removal of the BMS (4)	Hand
IX	Removal of the power electronics (5)	Hand
X	Cutting of the bus for the thermo sensors	Side cutters
XI	Disassembly of the system cover (6)	Screw driver
XII	Removal of the system cover (6)	Hand
XIII	Unscrew of the cable guiding (7)	Screw driver
XIV	Removal of the cable guiding (7)	Hand
XV	Removal of the gas venting (8)	Hand
XVI	Removal of the cover of stacks (9)	Hand
XVII	Disassembly of the connectors between the stacks (10)	Screw driver
XVIII	Removal of the connectors between the stacks (10)	Hand
XIX	Unscrew of the stack holders (11)	Screw driver
XX	Removal of the stack holders (11)	Hand
XXI	Removal of the casing bottom (12)	Hand
XXII	Unscrew of the stack fastener (13)	Screw driver
XXIII	Removal of the stack fastener (13)	Hand
XXIV	Removal of stacks (14)	Hand

3.3. Disassembly priority graph

To receive an unambiguous order for the disassembly, a disassembly priority graph needs to be drawn up. The disassembly priority graph combines the identified disassembly steps with the precedence relations from the disassembly matrix. The disassembly steps are combined where applicable and brought into an order according to the matrix.

In case of the Audi Q5 Hybrid battery system, the disassembly priority graph can look as shown in Fig. 7. The loosening and removal of the cable guide, of the connectors between the stacks, of the stack holders and of the stack fasteners can each be combined into a joint disassembly step. With this disassembly priority graph one possible disassembly order has been determined.

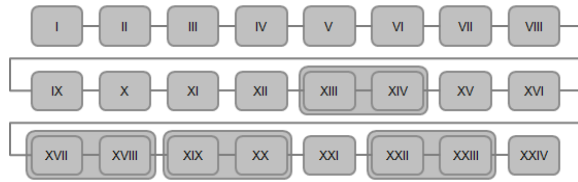

Fig. 7: Disassembly priority graph

4. Design concept of the disassembly system and work stations

Based on the battery design, the disassembly steps and the tasks involved, particular conclusions can be drawn for the complexity of the disassembly and for the concept of the disassembly system. In the following sections the challenges arising from the battery design are summarized. Subsequently, the main safety aspects to consider are given, before a concept for the disassembly system is proposed.

4.1. Conclusions from the battery system design

The analysis of the required disassembly steps regarding the battery design shows several aspects that increase the complexity of the disassembly. One difficulty arises from the many different screw types that have been used for the joints. This means that as many different types of screwdrivers have to be provided for the disassembly and that during the assembly a certain amount of time will be spent for changing the tool. Furthermore, not all screws are accessible from the same direction. The screw joints are at the top, at the side covers and at the bottom of the battery system. This will require several orientation changes of the tool and, due to the screw joints at the bottom of the battery system, even a turn-over of the whole battery or at least bottom accessibility. Further challenges for the disassembly, especially with a focus on future automation concepts, are flexible components such as cables and joints that are difficult to access such as the plug-in connectors of the BMS.

All these mentioned design aspects lead to the conclusion that a full automation of the disassembly process would be very complex to realize and thus very expensive. Therefore, a full automation is not reasonable, particularly with regard to the numbers of batteries that have to be disassembled, which are expected to be relatively low. However, a partial automation of the disassembly process should be considered, as the numbers of end-of-life batteries will increase. But even the realization of only partial automation is a challenging task since many of the disassembly operations require tactile skills. Being equipped with integrated torque sensors, the KUKA

Light Weight Robot (LWR) is qualified to be used for such operations and also for assisting the human worker. Therefore, the use of the LWR for the disassembly within a partly automated disassembly system should be considered.

4.2. Safety aspects

For the manual disassembly of the Q5 batteries, the main safety risks, i.e. the safety risks with the largest impact, are caused by the high voltage and the chemicals in the battery cells (mainly the electrolyte).

Though, in the future recycling process it is intended to discharge the batteries before the disassembly, in the current state of the project a disassembly of charged batteries still has to be considered. This is also reasonable in order to cover the cases of discharging failures. Therefore, in the design of the work stations appropriate protective measures for the worker and the environment are required like electrically isolated tools, hand gloves, shoes and floor cover.

A further safety risk arises from the electrolyte in the battery cells. In case of the damaging of a cell during the disassembly process the electrolyte may cause fire or toxic gases. In order to protect the worker, the work stations should be equipped with appropriate fire extinguishers (dry chemical or carbon dioxide), emergency kits, gas masks and an extraction unit.

4.3. Conclusions for the design of the disassembly system and work station

The data gained from the disassembly studies can be utilized to draw conclusions for the disassembly system on the one hand and the work station for the disassembly on the other.

4.3.1. Disassembly system

Based on product properties, the battery system being rather small with only two variants (Audi Q5 and VW Jetta), a small number of parts that need to be disassembled (14) and with rather low complex disassembly processes, the disassembly will be carried out in a single work station. The transfer of the battery systems that need to be disassembled will be carried out centralized via a roller conveyor and the material removal from the work space is carried out locally. There will be a flexible material flow.

4.3.2. Disassembly work station

The disassembly work station has been designed as depicted in Fig. 8. The batteries are transported from the stock to the work station by means of a conveying system. At the work station the battery system is placed on a table where either two workers or one worker and a robot (the KUKA LWR) disassemble the battery. For the human worker(s) the required (electrically isolated) tools are clearly arranged on a board and well accessible. On this board or next to it the fire extinguisher, emergency kit etc. should be placed. For the robot a tool changing system is provided. The disassembled

parts have to be separated into four categories: electronics, metals with iron, battery modules and residual materials. The battery modules are further transported to the next station which is either a further disassembly station or coarse shredding. In the whole work station all areas have to be well accessible within a short distance.

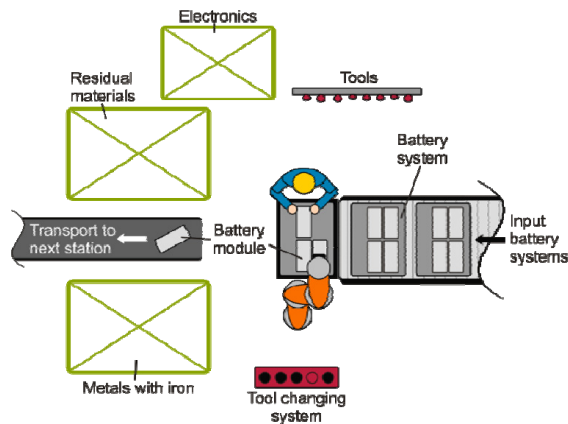

Fig. 8: Basic layout of the work station for the disassembly of the Q5 batteries

At the current state of the project, the batteries are disassembled manually by two workers. In the future the human worker should be assisted by a robot, as shown in Fig. 8. One task of the robot will be the loosening of screws and nuts. In order to identify the orientation of the screws and to place the tool correctly the LWR has to use its integrated sensors. In addition, the sensors enable the robot to operate in a compliant mode. In this mode the robot moves back when encountered with resistance (for example in a collision). This is an important property for team work with a human so that the robot cannot hurt the human seriously [19].

5. Conclusions

Using the example of the Audi Q5 Hybrid battery system, a planning approach for the disassembly of electric vehicle batteries has been demonstrated. Based on a priority matrix, a disassembly sequence for the Q5 battery system has been derived. Subsequently, the battery has been analyzed concerning the complexity of the disassembly before presenting a concept for the disassembly system and workstation. For the disassembly system a single work station with a centralized transfer of the batteries is proposed. Furthermore, the disassembly worker is proposed to be assisted by a compliant robot, which is to be detailed in future work.

Acknowledgements

The authors like to express their gratitude to all industry partners, especially Audi AG and Electrocyling GmbH, research partners from the Automotive Research Center

Niedersachsen (NFF) and the German Federal Ministry for the Environment, Nature Conservation and Nuclear Safety for supporting the projects ‘LithoRec – Recycling of Lithium-ion Batteries’ with the promotional reference 16EM0023 and ‘LithoRec II – Recycling of Lithium-ion Batteries’ with the promotional reference 16EM1021.

References

- [1] Bundesministerium für Wirtschaft und Technologie, Bundesministerium für Verkehr, Bau und Stadtentwicklung, Bundesministerium für Umwelt, Naturschutz und Reaktorsicherheit, Bundesministerium für Bildung und Forschung. Regierungsprogramm Elektromobilität. Berlin; 2011.
- [2] Kwade A, Bärwaldt G (eds.). LithoRec: Recycling von Lithium-Ionen-Batterien. Göttingen: Cuvillier; 2012.
- [3] Federal Ministry for the Environment, Nature Conservation and Nuclear Safety (BMU). Renewably mobile: Marketable solutions for climate-friendly electric mobility. Berlin; 2013.
- [4] Eversheim, W., Hartmann, M., Linnhoff, M. (1992) Zukunftsperspektive Demontage, VDI-Z, vol. 134, no. 6, pp. 83-86.
- [5] Ohlendorf, M. (2006) Simulationsgestützte Planung und Bewertung von Demontagesystemen, Dissertation, Vulkan-Verlag, Essen.
- [6] Penev, K. (1996) Design of disassembly systems – a systematic approach, Dissertation, Eindhoven.
- [7] Hentschel, C. (1996) Beitrag zur Organisation von Demontagesystemen, Berichte aus dem Produktionstechnischen Zentrum Berlin, Dissertation, Berlin.
- [8] Limaye, K.G. and Caudill, R.J. (1999) Systems modeling and simulation of electronic demanufacturing facilities, Proceedings of the 1999 IEEE Int. Symposium on Electronics and the Environment, Danvers, Massachusetts, pp.238-243.
- [9] Santochi, M., Dini, G., Failli, F. (2002) Computer Aided Disassembly Planning: State of the Art and Perspectives CIRP Annals-Manufacturing Technology, Volume 51, Issue 2, pp 507-529.
- [10] Kara, S., Pornprasitpol, P., Kaebnick, H. (2006) Selective Disassembly Sequencing: A Methodology for the End-of-Life Products, Annals of the CIRP, Vol. 55/1.
- [11] Westernhagen, K. von (2001) Planung und Steuerung der Retro-Produktion, Dissertation, Vulkan Verlag, Essen
- [12] Güngör, A., Gupta, S.M., Pochampally, K. and Kamarthi, S.V. (2000) Complications in disassembly line balancing, Proceedings of SPIE International Conference on Environmentally Conscious Manufacturing, Vol. 4193, pp.289-298.
- [13] Lambert, A. J. D. (1997) Optimal disassembly of complex products, International Journal of Production Research, Vol. 35, No. 9, pp. 2509-2523.
- [14] Lee, D-H., Xirouchakis, P. and Züst, R. (2002) Disassembly scheduling with capacity constraints, CIRP Annals Manufacturing Technology, Vol. 51, No. 1, pp.387-390.
- [15] Herrmann, C., Raatz, A., Mennenga, M., Schmitt, J., Andrew, S. (2012) Assessment of Automation Potentials for the Disassembly of Automotive Lithium-ion Battery Systems, In: Leveraging Technology for a Sustainable World, Proceedings of the 19th CIRP Conference on Life Cycle Engineering, Berkeley, USA, Springer, Berlin Heidelberg, pp. 149-154, ISBN 978-3-642-29068-8
- [16] Eckerth, G. (2002) Planning of flexible automated disassembly systems, Proceedings of the CARE Innovation 2002, Austria, 25-28 November.
- [17] Ciupek, M. (2004) Beitrag zur simulationsgestuetzten Planung von Demontagefabriken fuer Elektro-und Elektronikaltgeraete, Dissertation, TU Berlin.
- [18] Wallentowitz, H., Unkonventionelle Fahrzeugantriebe, Institut für Kraftfahrzeuge, Aachen, 2006, 7. Aufl., S. 142
- [19] Bischoff R, Kurth J, Schreiber G, Koeppel R, Albu-Schäffer A, Beyer A et al. The KUKA-DLR Lightweight Robot arm - a new reference platform for robotics research and manufacturing. In: Robotics (ISR), 2010 41st International Symposium on and 2010 6th German Conference on Robotics (ROBOTIK); 2010, p. 1–8.