

AN ANALYSIS OF GROCERY STORE ENERGY USE

A Thesis

By

RALPH LUTHER COX III

Submitted to the Graduate College of  
Texas A&M University  
in partial fulfillment of the requirements for the degree of

MASTER OF SCIENCE

December 1993

Major Subject: Mechanical Engineering

AN ANALYSIS OF GROCERY STORE ENERGY USE

A Thesis

By

RALPH LUTHER COX III

Submitted to the Office of Graduate Studies of  
Texas A&M University  
in partial fulfillment of the requirements for the degree of

MASTER OF SCIENCE

Approved as to style and content by:

---

Jeff S. Haberl  
(Chair of Committee)

---

David E. Claridge  
(Member)

---

T.A. Reddy  
(Member)

---

A. Pedulla  
(Member)

---

G.P. Peterson  
(Head of Department)

December 1993

Major Subject: Mechanical Engineering



## ABSTRACT

An Analysis of Energy Use in Grocery Stores (December 1993)

Ralph Luther Cox III, B.S., Texas A&M University

Chairman of Advisory Committee: Dr. Jeff S. Haberl

Approximately 3% of the United States' commercial building energy consumption is attributable to food sales facilities. Although this is one of the smallest consumption percentages, it is still significant, amounting to about 151 trillion Btu, or \$2.17 billion per year. Food sales facilities ranging from 10,000 to 100,000 ft<sup>2</sup> use 3 to 5.5 W/ft<sup>2</sup> (32 to 60 W/m<sup>2</sup>) of electricity -- two to three times what typical office buildings of the same size use (EIA 1986). Identifying potentials for energy savings in food sales facilities is therefore a worth-while pursuit.

Why do people study energy consumption? According to Haberl et al. (1990), there are five different groups of people who can benefit from building energy monitoring and at least seven basic applications of energy monitoring projects. The five groups of beneficiaries are: the energy analyst; the energy consumer; governmental agencies; engineers, manufacturers, and contractors; and, utility and fuel suppliers. The seven basic applications are: energy consumption and load forecasting, evaluation of end-use energy data, the monitoring of energy savings from retrofits, determining system efficiencies, environmental quality issues, analyzing the human factor, and diagnosing operational and maintenance problems.

This thesis is a study of the energy use in supermarkets, which fall into the category of the energy consumer. This study is of interest to the energy analyst and the manufacturers of grocery store equipment, and to utilities which can use the results of energy consumption modeling procedures developed herein as inputs to load-predicting models. Many papers and reports have been written about the energy use in grocery stores. In general, they addressed three major issues: energy use surveys and market analyses, refrigeration and HVAC system improvements, and energy use modeling methods. This thesis extends the foregoing work by first performing a general energy use survey of over 90 grocery stores, and presenting statistics regarding their energy use characteristics. Then, several of the previous methods of energy consumption modeling are adapted and applied to the whole-

building and sub-metered component load data from two case study grocery stores. Two methods of modeling, multiple linear regression and principal component analysis are evaluated. Finally, a new method is developed and tested that allows for the accurate estimation of sub-metered loads without incurring the expense of collecting many months of hourly, sub-metered data.

## DEDICATION

This thesis is dedicated to by family, friends, and colleagues, without whose guidance and support this effort would not have been possible.

## ACKNOWLEDGMENTS

This project was funded and supported by the Texas Higher Education Coördinating Board, Energy Research and Applications Program under project number 227. We wish to express our gratitude. We also wish to thank the individuals at the Kroger Company who helped with the project -- Charles Hembree, the manager of facility engineering in Houston; Larry Medearis, the store manager at the College Station case study store; Bob Powell, the store manager at the Bryan store; and Gary Mills, the maintenance manager for the case study store.

## TABLE OF CONTENTS

	Page
ABSTRACT .....	iii
ACKNOWLEDGMENTS .....	vi
TABLE OF CONTENTS.....	vii
LIST OF FIGURES .....	xii
LIST OF TABLES .....	xviii
CHAPTER I INTRODUCTION.....	1
1.1 BACKGROUND .....	1
1.2 LITERATURE REVIEW .....	3
1.2.1 Energy Use Surveys and Market Analyses .....	3
1.2.2 Refrigeration and HVAC System Improvements .....	6
1.2.3 Energy Use Modeling Methods .....	9
Chapter II THE SURVEY STUDY .....	18
2.1 SURVEY METHODS .....	18
2.2 SURVEY RESULTS .....	20
2.3 SUMMARY .....	31
CHAPTER III CASE STUDY .....	33
3.1 BUILDING STRUCTURE OF COLLEGE STATION STORE .....	33
3.2 MAJOR ELECTRICAL EQUIPMENT OF COLLEGE STATION STORE.....	35
3.2.1 Refrigeration Equipment.....	35
3.2.2 HVAC Equipment .....	37
3.2.3 Lighting.....	42
3.2.4 Miscellaneous Utility .....	43
3.2.5 Natural Gas .....	45

3.3 ELECTRICAL SUB-METERING OF COLLEGE STATION STORE...	45
3.4 ENERGY CONSUMPTION DATA FOR COLLEGE STATION STORE.....	51
3.4.1 Summary Plots and 3D Inspection Plots.....	54
3.4.2 Constant and Schedule-dependent Loads .....	62
3.4.3 Temperature-dependent Loads.....	66
3.5 BUILDING STRUCTURE OF BRYAN STORE .....	71
3.6 MAJOR ELECTRICAL EQUIPMENT OF BRYAN STORE.....	71
3.6.1 Refrigeration Equipment.....	73
3.6.2 HVAC Equipment .....	75
3.6.3 Lighting.....	75
3.6.4 Miscellaneous Utility .....	80
3.6.5 Natural Gas .....	80
3.7 ELECTRICAL SUB-METERING OF BRYAN STORE.....	80
3.8 ENERGY CONSUMPTION DATA FOR BRYAN STORE.....	85
3.8.1 Summary Plots.....	85
3.8.2 Constant and Schedule-dependent Loads .....	89
3.9 SUMMARY.....	94
CHAPTER IV CP/PCA AND CP/MLR MODELING.....	97
4.1 BACKGROUND .....	97
4.2 MODEL IDENTIFICATION.....	106
4.2.1 Above-CP Region.....	106
4.2.2 Below-CP Region .....	110
4.3 MODEL COMPARISON: PCA VS. MLR .....	114
4.4 PHYSICAL SIGNIFICANCE OF MODEL PARAMETERS.....	123
4.4.1 Variation Due to Solar Load .....	123
4.4.2 Variation Due to Temperature .....	124

4.5 SUMMARY.....	129
CHAPTER V END-USE LOAD ESTIMATION.....	131
5.1 MODEL OVERVIEW FOR THE COLLEGE STATION STORE.....	131
5.2 BIN MODEL APPLICATION FOR THE COLLEGE STATION STORE.....	141
5.2.1 Binned Temperature Models .....	141
5.2.2 Alternative Lighting Model .....	150
5.3 ALTERNATIVES TO SUB-METERING FOR THE COLLEGE STATION STORE.....	157
5.3.1 Base Loads .....	158
5.3.2 Varying Loads.....	163
5.3.3 Load Disaggregation.....	165
5.4 MODEL OVERVIEW FOR THE BRYAN STORE.....	170
5.5 BIN MODEL APPLICATION FOR THE BRYAN STORE .....	174
5.6 ALTERNATIVES TO SUB-METERING FOR THE BRYAN STORE.....	183
5.6.1 Varying Loads.....	187
5.6.2 Load Disaggregation.....	188
5.7 SUMMARY.....	194
CHAPTER VI DISCUSSION AND CONCLUSIONS .....	197
6.1 Review of objectives.....	197
6.2 CONCLUSIONS .....	198
6.2.1 93-Grocery Store Survey .....	198
6.2.2 Sub-metering of Local Case Study Stores .....	199
6.2.3 Test of Regression Methods .....	200
6.2.4 End-use Load Estimation.....	201
REFERENCES .....	204

APPENDIX A DATA PROCESSING .....	208
A.1 REVIEW OF MEASUREMENT TECHNIQUES .....	208
A.1.1 Basics of Electricity Monitoring.....	208
A.1.2 Measuring Temperature .....	209
A.1.3 Measuring Humidity .....	209
A.2 MONITORING EXPERIMENTS USED IN THE CASE STUDY STORES .....	212
A.3 USING A DATA LOGGER .....	221
A.3.1 Connecting the Sensors to the Logger .....	222
A.3.2 Survival Commands for Programming the College Station and Bryan Loggers.....	225
A.3.3 Setting Up and Polling a Logger.....	227
A.4 PROCESSING THE COLLEGE STATION AND BRYAN DATA.....	238
A.4.1 Processing/Plotting Synergistics Data .....	238
A.4.2 Description of the Summary Inspection Plots from Raw Synergistics Data and Area Weather Data.....	250
A.4.3 Creating a 3-D Graph Using Lotus 123 and Intex Solutions 3D Graph .....	259
A.5 DATA-PROCESSING ROUTINES .....	269
A.5.1 901SUM.BAT.....	269
A.5.2 901JOIN.BAT.....	272
A.5.3 901JOIN.AWK .....	273
A.5.4 901CHGRF.AWK.....	275
A.5.5 901CGRF8.AWK .....	275
A.5.6 901DATE.AWK .....	277
A.5.7 901DATE8.AWK .....	277
A.5.8 MAKESPAC.BAT.....	278
A.5.9 .PLT FILES.....	280



APPENDIX B BUILDING ENERGY USE SURVEY DATA .....	281
APPENDIX C INTERESTING FACTS NOTED DURING THE CASE STUDY .	301
C.1 OPERATIONAL PROBLEMS SPOTTED THROUGH SUMMARY PLOTS .....	301
C.2 DELAY IN ADJUSTMENT OF PARKING LOT TIMER .....	301
C.3 BIMODALITY IN REFRIGERATION AND HVAC ENERGY USE .	301
C.4 HOLE IN AIR-HANDLER UNIT DUCT SPOTTED .....	303
C.5 GAS USE AT THE BRYAN STORE .....	303
APPENDIX D TRANSLATION OF PCA PARAMETERS INTO MLR PARAMETERS .....	305
D.1 TRANSLATION RETAINING ALL PRINCIPAL COMPONENTS ...	305
D.2 TRANSLATION DROPPING ONE PRINCIPAL COMPONENT .....	307
APPENDIX E STATISTICAL ANALYSIS.....	310
E.1 DATA USED IN ANALYSIS.....	310
E.1.1 Building Electricity Load Data.....	310
E.1.2 Predictor Variable Data .....	317
E.2 STATISTICAL ANALYSIS ROUTINE.....	326
E.3 ANALYSIS OUTPUT.....	329
APPENDIX F SITE PHOTOGRAPHS .....	347
APPENDIX G PHYSICAL SIGNIFICANCE OF MODEL PARAMETERS: DIVERSIFIED LOAD CALCULATIONS.....	354
G.1 VARIATION DUE TO SOLAR LOAD .....	354
G.2 VARIATION DUE TO TEMPERATURE.....	362
VITA.....	364

## LIST OF FIGURES

		Page
1.1	Percentages of Total US Energy Consumption in Commercial Buildings ..	1
1.2	Beneficiaries and their uses of energy monitoring.....	2
2.1	Climatic Zones.....	19
2.2 a,b,c	Histograms of Store Floor Area, Electricity Consumption, and Natural Gas Consumption.....	21
2.3 a,b	Electricity Consumption and Electricity EUI vs. Floor Area .....	23
2.4 a,b	Electricity and Natural Gas EUIs vs. Climatic Zone Index .....	24
2.5	Heat Reclaim System Schematic .....	25
2.6 a,b,c	Floor Area, Electricity and Natural Gas EUIs vs. Construction Date.....	27
2.7 a,b	Nameplate Refrigeration Capacity and Refrigeration EUI vs. Construction Date.....	29
2.8 a,b	Nameplate Refrigeration Capacity and Refrigeration EUI vs. Floor Area	30
3.1	Plan view of the College Station grocery and video stores.....	34
3.2	Schematic of the indoor temperature conditions HVAC system control...38	
3.3	HVAC system control curves. The HVAC control thermostat has a range of six control curves (A-F).....	40
3.4	Four modes of HVAC system operation.....	41
3.5	Lighting schedule profile for a typical day at the College Station store ....	44
3.6	Data Acquisition Procedure .....	47
3.7	Sub-metered electrical circuit in College Station store .....	48
3.8	Historical Monthly Electricity Use from August 1988 to December 1992	49
3.9	Monthly natural gas consumption for College Station store .....	50
3.10 a,b	Percentages of Nameplate Contribution to Peak and Measured Contribution to Electricity Use for the College Station store .....	52
3.11	Summary inspection plots for College Station store .....	55

3.12 a,b	3D plot of whole-building electricity for College Station store .....	56
3.13 a,b	3D plot of sub-metered refrigeration compressors for College Station store	57
3.14 a,b	3D plot of sub-metered lighting for College Station store.....	58
3.15 a,b	3D plot of sub-metered combined store HVAC for College Station store	59
3.16 a,b	3D plot of sub-metered utility for College Station store.....	60
3.17 a,b	3D plot of sub-metered video store HVAC for College Station store .....	61
3.18 a-f	Scatter Plots of Daily Loads vs. Outdoor Dry-bulb Temperature for the College Station store.....	63
3.19 a-f	Scatter plots of Hourly Loads vs. Outdoor Dry-bulb Temperature for the College Station store.....	65
3.20 a,b	Bimodality of refrigeration load .....	69
3.21	Plan view of the Bryan grocery store.....	72
3.22	Lighting schedule profile for a typical day (01/01/93) at the Bryan store	.78
3.23	Utility load profile for a typical day (01/01/93) at the Bryan store.....	79
3.24	Sub-metered Electrical Circuit in the Bryan Store .....	82
3.25	Historical Monthly Electricity Use from January 1990 to January 1993 for the Bryan store .....	83
3.26	Monthly natural gas consumption for the Bryan store.....	84
3.27 a,b	Percentages of Nameplate Contribution to Peak and Measured Contribution to Electricity Use for the College Station store .....	86
3.28	Summary inspection plots for Bryan store.....	88
3.29 a-e	Scatter Plots of Daily Loads vs. Outdoor Dry-bulb Temperature for the Bryan store .....	90
3.30 a-e	Scatter plots of Hourly Loads vs. Outdoor Dry-bulb Temperature for the Bryan store .....	91
3.31	Lighting load versus outdoor specific humidity for the Bryan store.....	93
4.1	1989 and 1992 models of whole-building electricity data.....	100
4.2	Pearson Correlation Coefficients .....	102

4.3	Scatter Plot of 1989 MLR Model Predictions and 1992 Measured Data	115
4.4	Scatter Plot of 1989 PCA Model Predictions and 1992 Measured Data	.115
4.5	Scatter Plot of 1992 MLR Model Predictions and 1992 Measured Data	116
4.6	Scatter Plot of 1992 PCA Model Predictions and 1992 Measured Data	.116
4.7	Time series plot of building electricity loads.....	118
4.8	Time Series Plot of 1989 MLR Model Predictions and 1992 Measured Data.....	119
4.9	Time Series Plot of 1989 PCA Model Predictions and 1992 Measured Data.....	119
4.10	Time Series Plot of 1992 MLR Model Predictions and 1992 Measured Data.....	120
4.11	Time Series Plot of 1992 PCA Model Predictions and 1992 Measured Data.....	120
4.12	Time Series Plot of Model Residuals .....	121
5.1	Four-parameter change-point model.....	132
5.2	Refrigeration compressor data and temperature change-point model for the period 01/01/92 to 01/01/93 for College Station .....	136
5.3	Lighting data and constant linear model for the period 01/01/92 to 01/01/93 for College Station.....	138
5.4	Combined store HVAC data and temperature change-point model for the period 01/01/92 to 01/01/93 for College Station .....	139
5.5	Utility data and constant linear model for the period 01/01/92 to 01/01/93 for College Station .....	139
5.6	Whole-building electricity data and temperature change-point model for the period 01/01/92 to 01/01/93 for College Station .....	140
5.7	Addition of sub-metered electricity loads for College Station .....	140
5.8	Time series plot of daily average refrigeration compressor load for 1992 for College Station .....	146
5.9	Binned hourly electricity consumption for four-parameter refrigeration compressor model from 01/01/92 to 01/01/93 for College Station .....	146

5.10	Time series plot of daily average lighting load for 1992 for College Station	147
5.11	Binned hourly electricity consumption for constant linear lighting model from 01/01/92 to 01/01/93 for College Station.....	147
5.12	Time series plot of daily average, combined-store HVAC load for 1992 for College Station.....	148
5.13	Binned hourly electricity consumption for four-parameter combined-store HVAC model for 01/01/92 to 01/01/93 for College Station .....	149
5.14	Time series plot of daily average miscellaneous utility load for 1992 for College Station.....	151
5.15	Binned hourly electricity consumption for constant linear miscellaneous utility model from 01/01/92 to 01/01/93 for College Station .....	152
5.16	Time series plot of daily average whole-building load for 1992 for College Station .....	153
5.17	Binned hourly electricity consumption for four-parameter whole-building model from 01/01/92 to 01/01/93 for College Station.....	153
5.18	Diurnal pattern of lighting load and sine lighting model, 1992 for College Station .....	155
5.19	Binned annual electricity consumption for sine and four-parameter lighting models, 1992 for College Station .....	156
5.20	Box plot of the hourly lighting load profile for the period 01/01/92 to 01/01/93 for College Station.....	161
5.21	Hourly lighting schedule with preferred times for clamp-on load measurements for College Station store .....	162
5.22	Change-point models identified from utility bill data and sub-metered data for College Station .....	164
5.23	Model disaggregation showing maximum and minimum HVAC loads subtracted from whole-building model for College Station .....	169
5.24	Model disaggregation showing curve, Cproxy , for College Station.....	169
5.25	Refrigeration compressor data and temperature change-point model for the period 12/20/92 to 06/28/93 for Bryan store.....	172

5.26	Lighting data and constant linear model for the period 12/20/92 to 06/28/93 for Bryan store .....	172
5.28	Utility data and constant linear model for the period 12/20/92 to 06/28/93 for Bryan store .....	173
5.29	Whole-building electricity data and temperature change-point model for the period 12/20/92 to 06/28/93 for Bryan store.....	175
5.30	Addition of sub-metered electricity loads for Bryan store.....	175
5.31	Time series plot of daily average refrigeration compressor load for 1992 for Bryan store .....	181
5.32	Binned hourly electricity consumption for four-parameter refrigeration compressor model from 01/01/92 to 01/01/93 for Bryan store.....	181
5.33	Time series plot of daily average lighting load for 1992 for Bryan store	182
5.34	Binned hourly electricity consumption for constant linear lighting model from 01/01/92 to 01/01/93 for Bryan store .....	182
5.35	Time series plot of daily average, combined-store HVAC load for 1992 for Bryan store .....	184
5.36	Binned hourly electricity consumption for four-parameter combined-store HVAC model for 01/01/92 to 01/01/93 for Bryan store.....	184
5.37	Time series plot of daily average miscellaneous utility load for 1992 for Bryan store .....	185
5.38	Binned hourly electricity consumption for constant linear miscellaneous utility model from 01/01/92 to 01/01/93 for Bryan store .....	185
5.39	Time series plot of daily average whole-building load for 1992 for Bryan store.....	186
5.40	Binned hourly electricity consumption for four-parameter whole-building model from 01/01/92 to 01/01/93 for Bryan store .....	186
5.41	Change-point models identified from utility bill data and sub-metered data for the Bryan store .....	188
5.42	Model disaggregation showing maximum and minimum HVAC loads subtracted from whole-building model for Bryan store.....	190

5.43 Model disaggregation showing proxy curve Cproxy for Bryan store.....191

## LIST OF TABLES

		Page
1.1	Inter-relationships Between Energy-using Systems in a Supermarket .....	7
2.1	Parameters Included in Store Database.....	19
3.1	Refrigeration Compressor Summary for College Station.....	36
3.2	Description of End-use Loads Included in Group Breakdown for the College Station Store .....	53
3.3	Refrigeration Compressor Summary for Bryan Store.....	74
3.4	HVAC System Summary for Bryan Store .....	76
3.5	Description of Loads Included in Group Breakdown for the Bryan Store.	87
4.1a	Correlation Matrix for Old 1989 Data Set (all data).....	101
4.1b	Correlation Matrix for New 1992 Data Set (all data).....	101
4.2	Correlation Matrix for Ruch 1989 Data set above CP of 15.4°C (59°F).	104
4.3	Correlation Matrix for New 1992 Data set above CP of 18.7°C (65°F)..	104
4.4	Correlation Matrix for Ruch 1989 Data set below CP of 15.4°C (59°F)	105
4.5	Correlation Matrix for New 1992 Data set below CP of 18.7°C (65°F)	105
4.6	Eigenvectors for Ruch 1989 PCA Model above CP of 15.4°C (59°F)....	107
4.7	Eigenvectors for 1992 PCA Model above CP of 18.7°C (65°F) .....	107
4.8	Regression Summary: 1989 Models as Used on 1992 Whole-building Data Above CP of 15.4°C (59°F).....	108
4.9	Regression Summary: 1992 Models as Used on 1992 Whole-building Data Above CP of 18.7°C (65°F).....	109
4.10	Eigenvectors for 1989 PCA Model below CP of 15.4°C (59°F).....	110
4.11	Eigenvectors for 1992 PCA Model below CP of 18.7°C (65°F).....	110
4.12	Regression Summary: 1989 Models as Used on 1992 Whole-building Data Below CP of 15.4°C (59°F).....	112



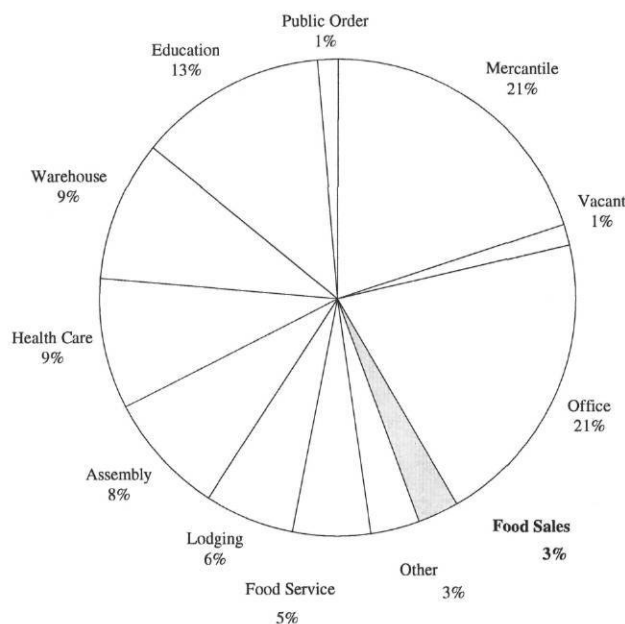
4.13	Regression Summary:1992 Models as Used on 1992 Whole-building Data Below CP of 18.7°C (65°F).....	113
4.14	Summary of Performance of Models over 1992 Data Set .....	114
4.15	Percent Differences in Model Parameters for 1989 and 1992 Models ....	117
4.16	Percent Differences in Model Parameters for PCA compared to MLR...	122
4.17	Regression Summary: 1992 HVAC Models Above CP of 18.7°C (65°F)	126
4.18	Regression Summary: 1992 HVAC Models Below CP of 18.7°C (65°F)	127
5.1	Bin Simulation for 4-P Refrigeration Model for College Station Store ..	142
5.2	Bin Simulation for Constant Linear Lighting Model for College Station Store .....	142
5.3	Bin Simulation for 4-P HVAC Model for College Station Store .....	143
5.4	Bin Simulation for Constant Linear Utility Model for College Station Store .....	143
5.6	Annual Summary of Sine Model and Four-P Model for Lighting.....	157
5.7	Sources of Model Identification Data for College Station Store .....	168
5.8	Bin Simulation for 4-P Refrigeration Model for Bryan Store .....	178
5.9	Bin Simulation for Constant Linear Lighting Model for Bryan Store .....	178
5.10	Bin Simulation for 4-P HVAC Model for Bryan Store .....	179
5.11	Bin Simulation for Constant Linear Utility Model for Bryan Store .....	179
5.12	Summary of Bin Simulation for Component Models for Bryan Store ....	180
5.13	Sources of Model Identification Data for Bryan Store .....	193

## CHAPTER I

### INTRODUCTION

#### 1.1 BACKGROUND

Approximately 3% of the United States' commercial building energy consumption is attributable to food sales facilities, as shown in Figure 1.1. Although this is one of the smallest consumption percentages, it is still significant, amounting to about 151 trillion Btu, or \$2.17 billion per year. Food sales facilities ranging from 10,000 to 100,000 ft<sup>2</sup> use 3 to 5.5 W/ft<sup>2</sup> (32 to 60 W/m<sup>2</sup>) of electricity -- two to three times what typical office buildings of the same size use (EIA 1986). Identifying potentials for energy savings in food sales facilities is therefore a worth-while pursuit.



**Figure 1.1**

*Percentages of Total US Energy Consumption in Commercial Buildings (Source of data: EIA 1986).*

Why do people study energy consumption? According to Haberl et al. (1990), There are five different groups of people who can benefit from building energy monitoring and at least seven basic applications of energy monitoring projects. The five groups of beneficiaries are: the energy analyst; the energy consumer; governmental agencies; engineers, manufacturers, and contractors; and, utility and fuel suppliers. The seven basic applications are: energy consumption and load forecasting, evaluation of end-use energy data, the monitoring of energy savings from retrofits, determining system efficiencies, environmental quality issues, analyzing the human factor, and diagnosing operational and maintenance problems. Figure 1.2 is a matrix of the beneficiaries and uses of energy monitoring. In it, the reader can see that the energy consumer is primarily interested in environmental quality issues, operational and maintenance problems, retrofit energy savings, and system and component evaluation.

	Energy analyst	Energy consumer	Governmental agencies	Manufacturers and contractors	Utility and fuel suppliers	
	✓		✓	✓	✓	Analyzing the human factor
			✓		✓	Conservation, planning, and forecasting
			✓		✓	End-use energy data
	✓	✓	✓	✓	✓	Environmental quality issues
		✓		✓		Operation and maintenance problems
	✓	✓	✓		✓	Retrofit energy savings
	✓	✓		✓	✓	System and component evaluation

**Figure 1.2**

*Beneficiaries and their uses of energy monitoring (Adapted from data in Haberl et al.(1990)).*

This thesis is a study of the energy use in supermarkets, which fall into the category of the energy consumer. The four factors listed above affect the profitability of the sale of food and other merchandise. This study is also of interest to the energy analyst, utilities, and the manufacturers of grocery store equipment.

## 1.2 LITERATURE REVIEW

Many papers and reports have been written about the energy use in grocery stores. In general, they addressed three major issues: energy use surveys and market analyses (FEA [1977], DOE [1981]), refrigeration and HVAC system improvements (Adams [1985], Adams [1992], Khattar [1991]), and energy use modeling methods (Howell [1993], Hill and Lau [1993], Wong [1988], Khattar et al. [1991], Fels [1986], Shrock and Claridge [1989], Ruch and Claridge [1991], Chen [1991], Ruch et al. [1991], Wu et al. [1992], Reddy and Claridge [1993]).

### 1.2.1 Energy Use Surveys and Market Analyses

In 1977, the Federal Energy Administration (FEA) published its *Guide to energy Conservation for Grocery Stores*, in which it stated that food retail establishments comprise about 3% of the nation's total energy use, and 4% of the nation's electricity use. Grocery stores typically experience energy costs which are 1 to 3% of their sales. This amount often exceeds profits (FEA 1977). The FEA found that for the more than 200,000 food retail outlets in 1977 typical total<sup>1</sup> energy use for stores of given average floor area was as follows:

Store Size (ft <sup>2</sup> [m <sup>2</sup> ])	Annual Energy Consumption (kWh/yr)	Energy Use Intensity (W/ft <sup>2</sup> [W/m <sup>2</sup> ])
5,000 (465)	670,000	15.3 (165)
13,500 (1255)	1,750,000	14.8 (159)
30,000 (2788)	3,630,000	13.8 (149)

<sup>1</sup> This includes electrical and non-electrical energy converted to kWh.

During this period, a concerted effort was made to improve the energy performance of supermarkets. The values for energy use intensity ( $W/ft^2$ ) have decreased significantly in the years since the FEA study was published.<sup>2</sup>

Four years after the FEA report, the Department of Energy (DOE), in cooperation with Oak Ridge National Laboratory (ORNL), conducted a study to investigate the potentials for energy-efficient supermarket refrigeration systems (DOE 1981). ORNL performed a market analysis detailing the overall structure of the supermarket industry as well as the distribution of energy-using equipment in that industry. The "supermarket industry" was defined as "the cumulative total of all retail outlets in the country dealing in the sale of food, food-related and accompanying items, and the associated organizational structures, distribution systems, equipment suppliers, and support organizations necessary to retail food sales." (DOE 1989 p. xix) Today's supermarkets are still included in that definition, but have grown beyond it by often stocking dry goods and items not related to food or household needs. ORNL found that for the 175,820 food retail outlets surveyed in 1981 typical total energy use for stores of given average floor area was as follows:

Store Size (ft <sup>2</sup> [m <sup>2</sup> ])	Annual Energy Consumption (kWh/yr)	Energy Use Intensity (W/ft <sup>2</sup> [W/m <sup>2</sup> ])
6,000 (558) or less	118,600	4.51 (48.6)
6,000 (558) or more	2,060,000	9.22 (99.2)
25,000 (2323) or more	2,000,000	9.13 (98.3)

The survey performed in this thesis, in 1992, presents data which are comparable to those in the ORNL study. The average energy use intensities in the 1992 thesis survey were:

Store Size (ft <sup>2</sup> [m <sup>2</sup> ])	Annual Energy Consumption (kWh/yr)	Energy Use Intensity (W/ft <sup>2</sup> [W/m <sup>2</sup> ])
---	---------------------------------------	---

<sup>2</sup> The FEA values seem quite high compared to the values of 7 to 9  $W/ft^2$  found in the survey performed for this thesis.

40,000 (3717) or less	2,676,000	9.5 (102)
40,000 to 50,000	3,173,000	8.2 (87.9)
50,000 (4647) or more	3,973,000	7.7 (82.9)

---

Neither the ORNL study nor this thesis list energy use intensities which are comparable to those of the FEA.

Equipment analysis in the study focused mainly on refrigeration systems, but provided some general statistics for all systems found in typical stores. The ultimate goal of the ORNL study was to produce a model to investigate the potential benefits of various energy-efficient refrigeration equipment. They recommended a system consisting of unequally sized, parallel compressors, condensers controlled by floating-head pressure, and microprocessor electronic control of the system pressures, for installation as a retrofit for stores using standard, dedicated refrigeration compressor systems.

ORNL cited FEA (1977) in claiming that refrigeration systems in typical supermarkets often comprise 40 to 60% of the total in-store energy consumption. Of this, 15% is often attributable to case lights and fans. Likewise, HVAC systems comprise 15% to 20%, lighting 20% to 25%, and miscellaneous utility 5% to 10%.<sup>3</sup> ORNL noted that while any of these systems could be improved, complex relationships between them may make improvements in one detrimental to another. The study found that typical supermarkets have about 200 horsepower of refrigeration compressors and about 50 tons of air-conditioning capacity.<sup>4</sup> At the time, only ten percent of the compressors systems in supermarkets were energy-efficient, parallel systems. ORNL concluded that there was much opportunity for energy savings. ORNL discussed how the various energy-using systems in the store affected one another. Inter-relationships between these system are as listed in Table 1.1.

---

<sup>3</sup> In the thesis study, for the College Station store, electricity end-use percentages were 29% for refrigeration compressors, 21% for HVAC, 31% for lighting, and 19% for miscellaneous equipment and receptacles (including display case fans and anti-sweat heaters).

<sup>4</sup> ORNL did not specify what a "typical" store is, but the two stores studied for this thesis had about 100 tons of air-conditioning capacity each, amounting to roughly 460 ft<sup>2</sup>/ton, and between 165 and 200 hp of refrigeration capacity each.

## 1.2.2 Refrigeration and HVAC System Improvements

Adams (1985) noted that supermarkets have HVAC requirements not seen in other commercial buildings that do not have refrigeration<sup>5</sup>. He found that there exist several potentials in supermarkets to optimize the interactions between the HVAC and refrigeration systems. However, as of 1985, those systems were still handled by different ends of the HVAC&R industry. According to Adams, there had been little effort to organize information about the design and operation of HVAC and refrigeration systems in concert. Thus, the single greatest influence on system purchasing decisions is the persuasion of the equipment salesperson. Adams listed several ways in which standard commercial HVAC systems could be tailored for use in supermarkets by taking advantage of the refrigeration system's effects. These supermarket HVAC units might include under-floor return air ducts which allow cool, dry air escaping from display cases to be recycled immediately into the HVAC return mixing *after* the cooling coils; tighter building construction which reduces infiltration heat loads; evaporators in the air-conditioning system which are designed for moisture removal; supply air distribution at the front of the store to provide fresh, conditioned air at the point-of-sale area for customer and employee comfort; humidity control; heat reclaim from the refrigeration system; and, night set-back operation. But, Adams says that "[the] market for specialized supermarket HVAC equipment -- 1000-plus new stores in 1983 -- is too small to attract more than a few manufacturers. These are the smaller, custom HVAC companies. At the most, 10% of new stores in 1983 were equipped with supermarket HVAC units".

Adams (1992) stated that the primary goal in the design and operations of supermarkets is to maximize sales. Refrigerated merchandisers and display cases are crucial to this effort, and their ability to attract the customer has always taken precedence over energy efficiency issues. The more attractive and easily accessible display cases are those which are less energy-efficient; efficient compressor systems have higher initial costs, and without careful consideration may appear to be unattractive investments for the store management.

---

<sup>5</sup> This is due to the interactions between a store's HVAC system and its refrigeration system.

TABLE 1.1  
Inter-relationships Between Energy-using Systems in a Supermarket  
(adapted from DOE [1981])

System	Affects	Affected by
<b>Refrigeration</b>	<ul style="list-style-type: none"> <li>• HVAC load</li> </ul>	<ul style="list-style-type: none"> <li>• HVAC via heat reclaim</li> <li>• heat from case lighting</li> <li>• ambient space conditions</li> <li>• food temperature requirements</li> <li>• heat from case anti-sweat heaters</li> <li>• customer use</li> </ul>
<b>HVAC</b>	<ul style="list-style-type: none"> <li>• ambient space conditions</li> <li>• refrigeration system</li> </ul>	<ul style="list-style-type: none"> <li>• outdoor ambient conditions</li> <li>• refrigeration loads</li> <li>• heat from lighting loads</li> <li>• heat from misc. loads</li> <li>• customer occupancy</li> </ul>
<b>Lighting</b>	<ul style="list-style-type: none"> <li>• HVAC load</li> <li>• refrigeration load</li> </ul>	<ul style="list-style-type: none"> <li>• store operating schedule</li> <li>• number of daylight hours/day</li> </ul>
<b>Miscellaneous</b>	<ul style="list-style-type: none"> <li>• HVAC load</li> <li>• refrigeration load</li> </ul>	<ul style="list-style-type: none"> <li>• store operating schedule</li> <li>• customer use</li> </ul>



Adams found that the development of cost-to-display numbers can be used to help management make better-informed decisions about which systems to purchase. For example, in comparing an open, roll-in milk display without glass doors to a sealable display cooler with an enclosure on the back and a glass door in the front between the product and the customer. The difference in refrigeration cost was 3.5%, or \$115 per linear foot of display case per year. For a typical 72-ft display case, this amounts to \$8,280 which is the profit on \$552,000 worth of annual sales.<sup>6</sup> Thus, once a display case is installed, a store which uses the roll-in display case versus a closed door case must sell \$552,000 more merchandise to justify the its higher operating cost. Management is responsive to persuasion to use the efficient display cases, such as those with glass doors, if it can be shown that overall profitability is increased. This thesis takes advantage of the advice of Adams in providing information to the management of the case study stores in relation to the costs associated with any operational problems noticed through the energy monitoring, and provides owners of multiple grocery stores with a procedure to estimate the electrical end-use consumption without expensive sub-metering.

In an effort to bring together the technologies which serve the needs of supermarkets, the Electric Power Research Institute (EPRI) has published several studies on supermarket refrigeration and HVAC systems. As part of this effort, Khattar (1991) discussed new HVAC systems and requirements for supermarkets. He stressed the significance of indoor humidity control as the principal factor which distinguishes grocery stores from other commercial HVAC users. This discussion pertains to this thesis since dehumidification control is used in one of the two case study grocery stores.

The control of indoor humidity is important. Too little humidity can damage merchandise such as produce and meat. Too much humidity unduly burdens the refrigeration system. Both the HVAC system and the refrigeration display case coils have the effect of removing moisture from the air. But if the humidity removal is performed chiefly by the refrigeration system, it is inefficient because the moisture must be *frozen* out of the air rather than being condensed out by the HVAC coils. The ice that subsequently collects on the refrigeration coils must then be thawed by defrost heating since it otherwise decreases the heat transfer capacity of the coils. In addition,

---

<sup>6</sup> Adams uses a before-taxes profit of 1.5%.

in a humid store, anti-sweat heaters must be installed in display case doors to prevent condensation.

While exposing the refrigeration cases to moist space air does have the effect of dehumidifying it, Khattar states that HVAC systems are much more efficient at removing moisture from the air than refrigeration cases. The 50% relative humidity values which are common in grocery stores without dehumidification are merely coincidental to the cooling effect produced by the HVAC systems (set at about 75°F [24°C]). When conventional systems are used to reduce the humidity below 50%, the resulting air is too cold, and must be reheated. According to Khattar, alternative methods of dehumidification include gas-fired desiccant systems, dual-path electric air-conditioning systems<sup>7</sup>, and recycling of cool space air collected near refrigerated areas.<sup>8</sup> All of these methods allow for air-flow rates to be lowered from the conventional 0.7 to 1 CFM per square foot of floor area to as low as 0.5 CFM/ft<sup>2</sup>. The first case study grocery store in this thesis has a flow rate of 0.78 CFM/ft<sup>2</sup>. Dehumidification is provided during the heating season by using the cooling coils when the store's relative humidity goes above 55%.

### 1.2.3 Energy Use Modeling Methods

Howell (1993) developed a mathematical procedure to evaluate the theoretical effects of in-store ambient relative humidity on the energy use of single- and multi-shelf supermarket refrigeration cases both with and without case doors. The theoretical results of the model were compared with limited experimental data for ten types of display cases, with uncontrolled values of relative humidity. Howell found that agreement between the theoretical and actual energy use ranged from 0.3%, for multi-shelf deli cases with no doors, to 135% for single-shelf frozen food cases with no doors. Of the ten cases modeled, the theoretical energy use predictions for only four agreed to within 20% of the actual values. Considering this acceptable level of error, Howell used the model to determine the correlation between varying relative humidity and the energy use of the display case. As one might expect, higher store relative humidities resulted in higher required energy input to the refrigeration system. Savings in refrigeration case energy use due to changing from 55% relative humidity

---

<sup>7</sup> A dual-path system has separate cooling coils -- one for conditioning the return air, and one for conditioning the incoming outdoor air. The air streams are mixed *after* being conditioned. This type of system can reduce the need for reheating since a significant portion of the dehumidification can be achieved without cooling the supply air to unsuitably low temperatures.

<sup>8</sup> This recommendation was also made by Adams (1985).

to 35% ranged from 5% (for cases with glass doors) to 29% for reach-in cases without doors. This seems to indicate that cases with glass doors are not as sensitive to store humidity as those without doors. Howell's work was significant in that it showed the importance of store humidity control. But, it did not detail any particular methods of maintaining a desired relative humidity, rather, merely the effects of doing so. Dehumidification is only used at one of the stores studied in this thesis, which does not attempt to make any conclusions regarding the effects of store dehumidification control on the display cases. However, the interactions between the refrigeration system and the HVAC system, via the heat reclaim coils used during dehumidification are explored.

Hill and Lau (1993) performed a study of six grocery stores at various locations in the United States examining the effectiveness of using heat pipe heat exchangers to provide dehumidification in the HVAC system. The heat pipe heat exchangers used to dehumidify the air were able to reduce the indoor dew-point to 50°F (10°C) or lower, amounting to a increase of 18% to 27% in the amount of moisture removed per unit of HVAC compressor energy use ( $\text{lb}_m/\text{kWh}$  or  $\text{kg}/\text{kWh}$ ). Hill and Lau reported an average resulting refrigeration energy savings of 0.65% per degree Fahrenheit of indoor dew-point reduction. However, while moisture removal efficiency increased, the use of the heat pipe heat exchangers to dehumidify the air had a minimal effect on the HVAC system's overall cooling efficiency. Hill and Lau noted that because of site-to-site variations in thermal building loads, no general conclusions could be drawn about the benefits of the application of heat pipe heat exchangers.

Other energy-saving measures in supermarkets were investigated by Wong (1988) who presented the results of an energy conservation retrofit on the lighting and refrigeration systems of a small grocery store (16,843  $\text{ft}^2$ ) in Seattle. This store did not have an air-conditioning system since what little cooling needs there were were provided by the intereffects between the refrigeration display cases and the ambient air. Lighting system modifications included changing from mercury vapor lamps to high-pressure sodium lamps, adding photocell controls to the lights, and partial lamp shut-off during selected operating and non-operating hours.

Refrigeration system modifications included strip curtains in stockroom freezers, and case doors installed on horizontal display cases. Wong did not comment on any effects the refrigeration system retrofits may have had on store comfort, though, Wong found that the store management was pleased with the savings and willing to cooperate in future retrofit measures. Hourly whole-building electricity use data for

pre- and post-retrofit periods were monitored with data-acquisition equipment. Annual energy consumption decreased 17%, from 86.4 to 71.8 kWh/ft<sup>2</sup>·yr.<sup>9</sup> Of this, refrigeration loads decreased 10%, and lighting loads decreased 36%. The pay-back period for all retrofits was 5.4 years. Because of utility billing structures involving peak load periods (time-differentiated billing), Wong measured energy savings on a monthly basis. He asked the reader how the actual, time-differentiated savings would compare with those from a computer simulation of the retrofit measures. Would such a simulation predict time-differentiated savings? In response to this question, it seems reasonable that a model capable of predicting hourly data could be used to both determine peak periods as well as evaluate energy savings during those periods if the utility billing structure is known. This thesis develops such models and employs them in predicting monthly energy consumption based on daily consumption and weather data (see Chapter 4). The coefficients of the daily models are also applied to hourly binned weather data (see Chapter 5). The models developed in the works cited below, as well as in this thesis, could be used to determine time-differentiated savings in a retrofit analysis.

Khattar et al. (1991) developed a computer model to predict the energy use of various configurations of supermarket refrigeration equipment based on system configuration, interaction with indoor and outdoor ambient conditions, defrost schedules, heat reclaim, and load correlations. The model could simulate the intereffects between HVAC and refrigeration equipment due to both the indoor ambient conditions and to a heat reclamation system. This model's ability to predict refrigeration system energy consumption was within 3% of field test measurements in a 42,139 ft<sup>2</sup> grocery store in California, though only after the model was calibrated using more than 200 channels of data sampled every 10 seconds. This type of modeling was deemed important for the design, selection, and operation of cost-effective equipment. The model was used to evaluate the energy use and pay-back periods of potential refrigeration system installations. Its only drawback is the extent of electrical and thermodynamic sub-metering required to calibrate the model. Its most important feature, however, is its modularity. The user of the model may add new components to the modeled system with ease.

---

<sup>9</sup> Energy consumption in the two case study stores monitored for this thesis were 77.4 and 69.6 kWh/ft<sup>2</sup>·yr. However, it should be noted that these stores differ from Wong's case study in that they have significant air-conditioning energy use.

Modeling the effects of climate on the energy-using systems in grocery stores is important when the goal is to see the effects of energy-saving measures without them being obscured by variations in the weather. The need for a robust means of modeling building energy use data in residential buildings based on climatic conditions has been addressed by Fels (1986) through the use of the Princeton Scorekeeping Method (PRISM). PRISM was developed to evaluate the energy savings realized by building retrofits in such a way "that the effects of conservation [were not] obscured by differences in weather from one year to the next." (Fels 1986 p. 5) It provided a means of tracking and presenting energy savings in a manner which was easy to understand. The weather-dependent heating energy consumption models used by PRISM consisted of three parameters -- a base-level energy consumption, a change-point temperature below which the heating load was a function of outdoor temperature, and a heating slope which represented the variation in heating energy use due to changes in outdoor temperature. This three-parameter model assumed that heating energy was not consumed when temperatures were above the change-point. This assumption worked well for heating-only (HO) models and, to a limited extent, with cooling-only (CO) models for residential buildings.

However, when applied to situations in which energy use is non-constant on either side of a change-point temperature, a four-parameter model with slopes on either side of the change-point may be more appropriate. This is, in fact, the type of model used in this thesis. The idea of expanding the three-parameter model into a four-parameter model was first proposed by Schrock and Claridge (1989), who developed a four-parameter change-point linear regression model for predicting the daily and hourly whole-building electricity use of a supermarket. The whole-building energy use data clearly revealed a change-point temperature of about 17°C (62°F). However, contrary to the PRISM assumption, slopes above and below the change-point were also apparent. The change-point was estimated visually. Their work also showed that predictor models identified from daily energy consumption data work as well as those identified from hourly data when used to predict the hourly, whole-building data. Daily models were found to be useful at identifying building operational problems which appeared as deviations from model predictions of energy use. A few short-comings of the whole-building models were that they were unable to identify operational problems in small pieces of equipment, and that the change-point temperature was estimated by visual inspection of the data. This presented a problem since visual inspection is subjective, and non-reproducible. Subsequent studies,



including this thesis, significantly improve on the estimation of the change-point. Schrock and Claridge noticed a pattern of hourly fluctuations in the whole-building energy use data, and suggested that it might be due to the operation of the time clocks which control the defrost schedules of the refrigeration cases. If these clocks were not synchronized properly, different defrost heaters might run at the same time, creating and unnecessarily high electrical demand. The work performed for this thesis includes sub-metering of the store's refrigeration system, as well as other end-use loads, and helps to identify the source of the wave behavior in order to verify Schrock and Claridge's hypothesis.

The work of Schrock and Claridge was extended by Ruch and Claridge (1991). Ruch and Claridge developed a four-parameter change-point modeling procedure using the same grocery store as Schrock and Claridge. The fourth parameter in the model was a slope for temperatures below the change-point.<sup>10</sup> Their study developed a rigorous, computerized method for determining the whole-building change-point temperature. In addition, Ruch and Claridge formally compared their new four-parameter model to the three-parameter model made using a cooling-only application of PRISM. It was found that the slope of the data below the change-point was appreciable, and that including a below change-point slope in the new model resulted in a statistically better fit for the data than did the 3-parameter PRISM model. This work used daily data only, citing the added noise and processing time which hourly data added as the reason for not using hourly data. This thesis uses the same modeling procedure to estimate end-use component loads as well as whole-building loads for grocery stores.

Researchers have seen a strong outdoor air temperature dependency in grocery store energy use as well as a large, non-weather-dependent base-level consumption, but have noted that other variables effect energy use as well. One of these researchers was Chen (1991). Chen applies principal component analysis in combination with a change-point modeling method to predict the energy use of the grocery store studied by Schrock and Claridge. Briefly stated, principal component analysis (PCA) is a statistical modeling technique involving data transformation that may be used, in theory, to provide a more accurate fit to data when the independent variables in the data are intercorrelated (not truly independent of one another). PCA transforms a set of  $n$  intercorrelated variables into a set of  $n$  independent, uncorrelated, and statistically

---

<sup>10</sup> This is the same procedure used in this thesis to estimate the change-point temperature for the case study grocery stores.

significant variables called *principal components*. If one of these independent variables is ignored, and a regression is performed on the remaining principal component variables, the resulting model parameter coefficients are more stable (have smaller standard errors) than they would have had if all  $n$  principal component variables had been regressed.<sup>11</sup> Chen reported that as a result of dropping one PC variable, the goodness-of-fit of the model decreases slightly, but, that the gain in parameter stability is considered to be worth the sacrifice in goodness-of fit. The resulting parameters may then be easily translated back into terms corresponding to the original variables, and are considered to better represent the effects of the regressor variables. The variable and parameter transformation methods are covered in more detail in Appendix D of this thesis. Chen stated that PCA has been used extensively in the field of meteorology (Henry and Hidy 1979) and in the study of residential space heating (Hadley and Tomich 1986). But, the use of PCA with change-point models by Chen represented the first combined application of these methods.

Attempts by other researchers (MacDonald and Wasserman 1988) to use standard multiple linear regression (MLR) techniques to predict building energy consumption as a function of climate variables have been plagued by intercorrelations between predictor variables. In a follow-up to Chen's work, Ruch et al. (1991) hypothesized that if predictor variables<sup>12</sup> in a change-point model were strongly correlated, the parameter estimates provided by standard multiple linear regression (MLR) would be inaccurate since not all of the predictor variables were independent of one another. Principle component analysis (PCA) was tested as a means of providing a more accurate change-point (CP) model when highly correlated variables are used. Ruch refined Chen's CP/PCA model, applying it to the same grocery store used by Ruch and Claridge (1991) and Schrock and Claridge (1989). For Ruch's analysis, PCA proved superior to MLR in separating out the effects of temperature, relative humidity, solar radiation, and customer count on the electricity consumption of the store.<sup>13</sup> Ruch did not determine how PCA compares to MLR when used to predict data from a period *different from that used to identify the models*. This thesis

---

<sup>11</sup> In fact, if all  $n$  PCs are used in the regression, the resulting model parameters, when back-transformed into terms of the original intercorrelated variables, are identical to those which would be obtained with standard multiple linear regression (MLR) analyses.

<sup>12</sup> These variables were outdoor dry-bulb temperature (°C), specific humidity (kg moisture/kg dry air), solar radiation (W/m<sup>2</sup>), and daily sales (\$/day).

<sup>13</sup> Ruch et al. evaluated PCA and MLR using the same year's worth of data from which the respective models were identified. But the ultimate goal of energy modeling is to predict energy use for future periods.

tests Ruch's 1989 PCA and MLR models on 1992 energy consumption data for the same store, and also compares the 1989 models to new PCA and MLR models identified from 1992 data.

Wu et al. (1992) compared PCA to MLR using measured energy use data from a large commercial building in central Texas. They modeled the building's space conditioning load as a function of outdoor dry-bulb temperature, specific humidity, solar radiation, and internal lighting and receptacle loads. Wu et al. stated that for the levels of correlation found in the predictor variables, there was no apparent justification for selecting PCA over MLR based on the criteria of model  $R^2$ , RMSE, and CV value. They concluded, however, that further investigation involving data sets which exhibit a wide range of correlation strengths for the regressor variables was required to determine if and when PCA is superior to MLR.

To further investigate when PCA is superior to MLR, Reddy and Claridge (1993) performed a study using one year's worth of synthetic energy data sequences generated from models of climatic data from three different locations in the U.S. These models were considered to be true values of the synthetic energy data. They took the predictions of these models and intentionally added random scatter in such a manner as to create synthetic data sets with various, prescribed  $R^2$  values and correlation coefficients between the regressor variables. Reddy and Claridge then used PCA and MLR methods to identify *new* models from the synthetic data sets, and compared these models to the original, true ones. They concluded that PCA should do a better job at identifying the true parameters of the model than MLR if either:

- a) *one or more* pair of regressor variables has correlation coefficients of 0.5 or higher, and the model  $R^2$  value is less than about 0.5.

or,

- b) *only one* pair of regressor variables has correlation coefficients of 0.8 or higher, regardless of the model  $R^2$  value.

The criteria used to judge the superiority of the modeling approach were: 1) how well each model re-identified the true model parameters and, 2) how well each identified the mean of data generated for another year. This thesis tests Reddy and Claridge's method to determine if their recommendations hold true for a grocery store.

This thesis extends the foregoing work by first performing a general energy use survey of over 90 grocery stores, and presenting statistics regarding their energy use



characteristics. Then, several of the previous methods of modeling energy consumption are adapted and applied to the whole-building and sub-metered component load data from the grocery store studied by Schrock and Claridge (1989). Models identified from 1992 data are compared to those identified from 1989 data by Ruch et al. (1991). The purpose of this effort is to verify the original findings of Ruch et al., and Wu et al., and to see if PCA performs better than MLR at identifying models based on data sets from different time periods. In addition, the two methods are further evaluated by a comparison to ASHRAE CLTDS<sup>14</sup> and building U·A energy load models.

Finally, a new method is developed and tested that will allow for the accurate estimation of sub-metered daily loads without incurring the expense of collecting many months of hourly, sub-metered data. Component electricity use models identified from sub-metered electricity load data are compared to models identified from less expensive, walk-through survey methods. The models are then applied in bin calculations to estimate yearly electricity loads. The ability to accurately estimate component end-use electricity loads without having to resort to months of expensive sub-metered hourly data can provide grocery store owners with valuable information about what electrical loads may be excessive and therefore in need of further attention. Such information can also provide electric utilities with valuable input data for load-forecasting models.

---

<sup>14</sup> CLTDS = Cooling Load Temperature Difference for Solar contribution. Refer to Knebel (1983).

## CHAPTER II

### THE SURVEY STUDY

With the goals of identifying key predictors of energy use and discovering the potentials for energy-saving retrofit measures, a project to monitor and assess the energy use of typical urban grocery stores was initiated. As part of this effort, a database for 93 grocery stores in the south Texas area was developed. These stores are all owned and operated by a single nationwide grocery retailer. In addition, two case study stores were monitored. Insight gained from the case studies is expected to be applicable to the 93 stores since most are of similar construction and geographic location. This section details the database/survey portion of this project.

#### 2.1 SURVEY METHODS

Data were obtained from recent annual utility bills for the 93 stores provided by the supermarket corporate management. Information was also obtained with a mail-in store survey questionnaire developed with the help of the regional chief facilities engineer of the retail chain. Data were compiled into a spreadsheet database, discussed with the chief facilities engineer, and spot-checked with visits to a local, case study store. Questionnaire and report parameters that were assembled into the database are listed in Table 2.1.<sup>1</sup>

Stores were indexed by climatic zones based on the annual wet-bulb degree hours above 66 °F (19°C). Ten zones were defined for the south Texas area -- zone #1 having the least degree-hours (least humid climate), and zone #10 having the most degree-hours (most humid climate), as shown in Figure 2.1 (adapted from Dubin and Long, 1978).

The second index used was a heating-type code which designated "e" for electric heating, "g" for gas, "E" for process reclaim heat with electric booster heat, and "G" for process reclaim heat with natural gas booster heat. These codes were used

---

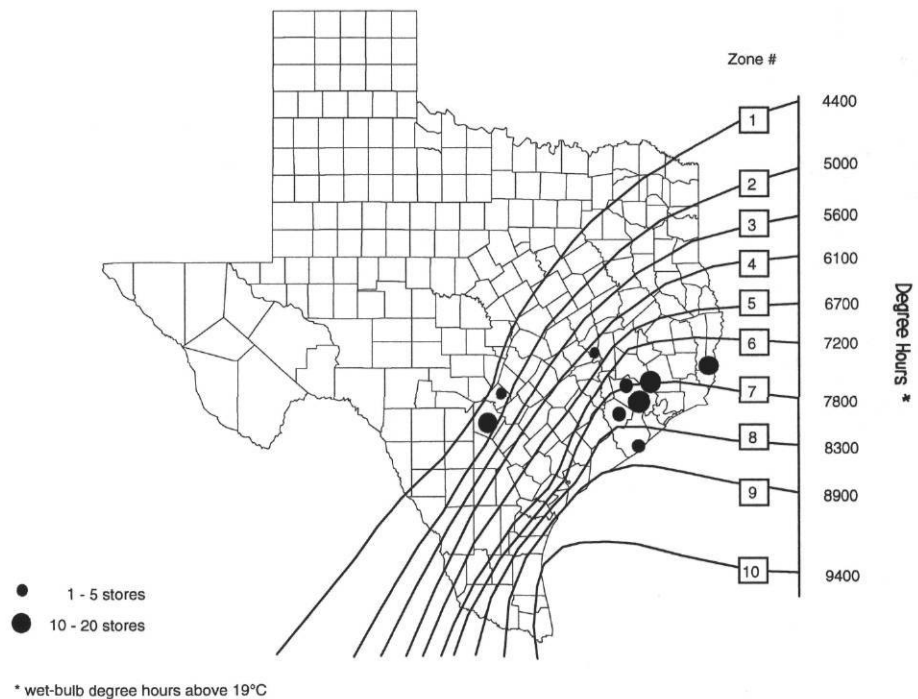
<sup>1</sup> Some parameters represented conditions as recorded during store construction. Others represented conditions at the time of the annual billing report. Refrigeration horsepower represented installed, rated capacity, and did not necessarily represent present operating conditions.

TABLE 2.1  
Parameters Included in Store Database

---

store location	annual electricity consumption per ft <sup>2</sup>
construction status	annual electricity cost
climatic zone index	annual electricity cost per ft <sup>2</sup>
floor area	annual natural gas consumption
hours per budgetary period	annual natural gas cost
store acquisition date	annual water consumption
recent store improvement date	annual water cost
source of heating	linear feet of freezers/coolers
installed refrigeration capacity	number of fluorescent lamps
annual electricity consumption	number and type of parking lot lamps
actual peak electric demand	method of thermostat adjustment
billed peak electric demand	method of inside lamp control
average daily electricity use	method of parking lot lamp control

---



**Figure 2.1**

*Climatic Zones. This figure shown the wet-bulb degree hours above 66°F (19°C) (adapted from Dubin and Long [1988]).*

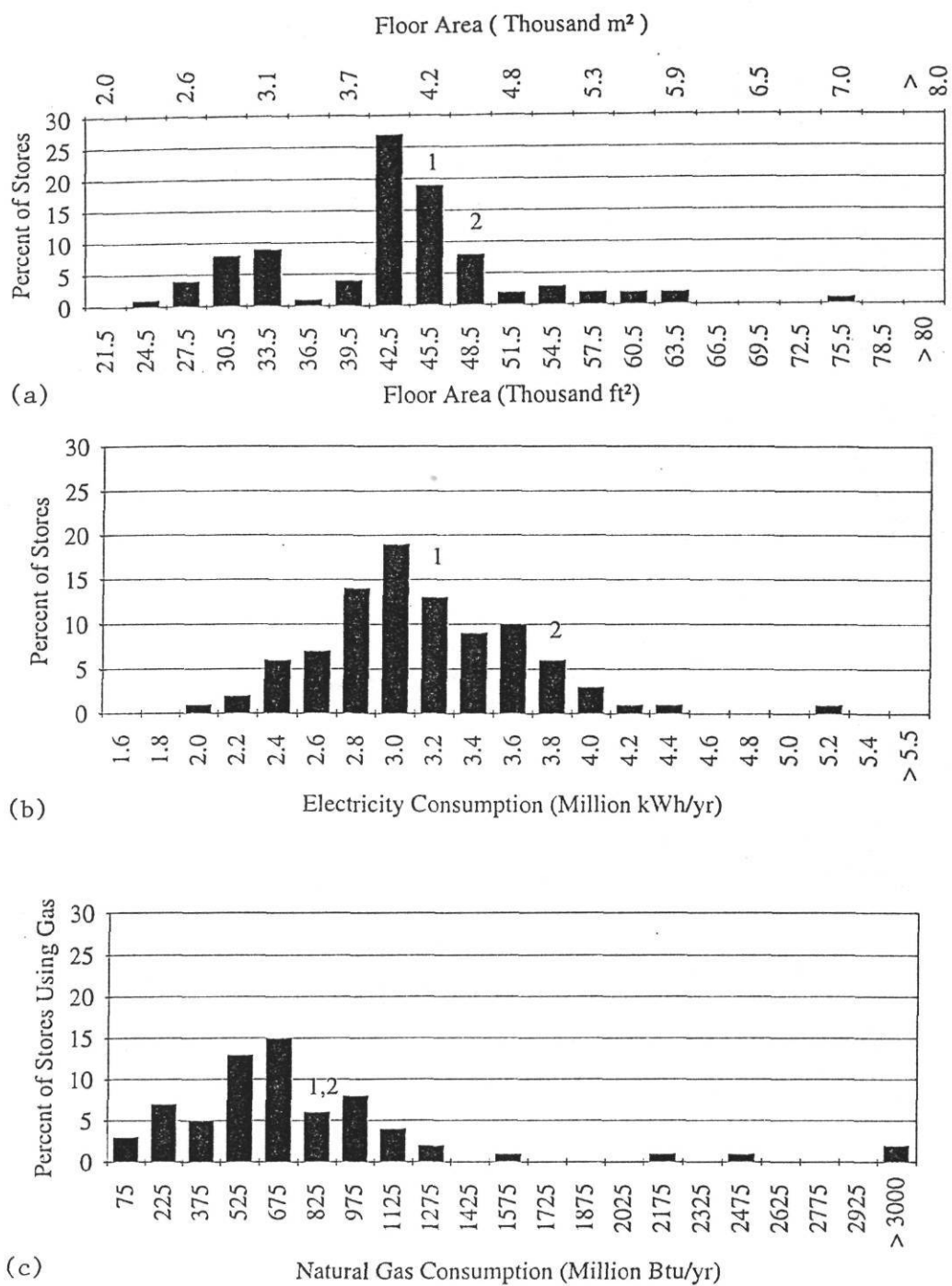
as data labels in several subsequent figures. The numbers "1" and "2" are used in these figures to refer to the College Station and Bryan case study stores, respectively. The College Station store uses reclaim heating with gas booster heat, while the Bryan store does not have reclaim heating, and uses natural gas fired duct heaters.

## 2.2 SURVEY RESULTS

Whole-building electricity use and store size were the most useful parameters. For the stores surveyed, the floor areas ranged from approximately 20,000 to 80,000 ft<sup>2</sup> (2,000 to 8,000 m<sup>2</sup>). The average store size was 43,000 ft<sup>2</sup> (4,000 m<sup>2</sup>), with 50% of the stores having floor areas between 41,000 and 47,000 ft<sup>2</sup> (3,800 and 4,400 m<sup>2</sup>) (see Figure 2.2a). While a number of the larger stores were built to more closely adhere to corporate specifications, some of the smaller stores were acquired from other retail chains, and did not meet all of the same standards.

Annual electricity consumption in 1990 ranged from about 1.5 to 6.0 GWh/yr (million kWh/yr), with 70% of the stores consuming between 2.7 and 3.7 GWh/yr, as shown in Figure 2.2b. Of the 68 stores using natural gas, approximately 70% consumed between 300 and 1,000 million Btu/yr (see Figure 2.2c).

Interestingly, one of the most revealing ways of looking at trends in the energy use was the use of simple scatter plots. An energy use intensity (EUI) was defined for electricity and natural gas consumption. The electricity EUI (W/ft<sup>2</sup> or W/m<sup>2</sup>) was created for the annual electricity use (kWh/ft<sup>2</sup>-yr or kWh/m<sup>2</sup>-yr) to represent an average electricity intensity. EUIs were also defined for refrigeration nameplate capacity (W/ft<sup>2</sup> or W/m<sup>2</sup>), and natural gas use (Btu/m<sup>2</sup>-yr).



**Figure 2.2 a,b,c**

*Histograms of Store Floor Area, Electricity Consumption, and Natural Gas Consumption. Annual electricity consumption in 1990 ranged from 1.5 to 6.0 GWh/yr, with 70% of the stores consuming 2.7 to 3.7 GWh/yr. Of the 68 stores using natural gas, 70% consumed between 300 and 1,000 million Btu/yr.*

As expected, Figure 2.3a shows an increase in electricity consumption as floor area increases. On average, stores tended to have an electricity EUI of roughly 9 W/ft<sup>2</sup> (96.9 W/m<sup>2</sup>), and varied to extremes by  $\pm 2$  W/ft<sup>2</sup> ( $\pm 21.5$  W/m<sup>2</sup>), as shown in Figure 2.3b. These values differ from those presented by EIA (1986)<sup>2</sup> by an about 100%. Stores smaller than 40,000 ft<sup>2</sup> had an average electricity EUI of  $9.5 \pm 1.7$  W/ft<sup>2</sup> ( $102 \pm 18$  W/m<sup>2</sup>) ( $\pm$  twice the sample standard deviation). Stores larger than 50,000 ft<sup>2</sup> had an average EUI of  $7.7 \pm 1.1$  W/ft<sup>2</sup> ( $83 \pm 12$  W/m<sup>2</sup>). Stores between 40,000 and 50,000 ft<sup>2</sup> had an average EUI of  $8.2 \pm 1.4$  W/ft<sup>2</sup> ( $88 \pm 15$  W/m<sup>2</sup>).

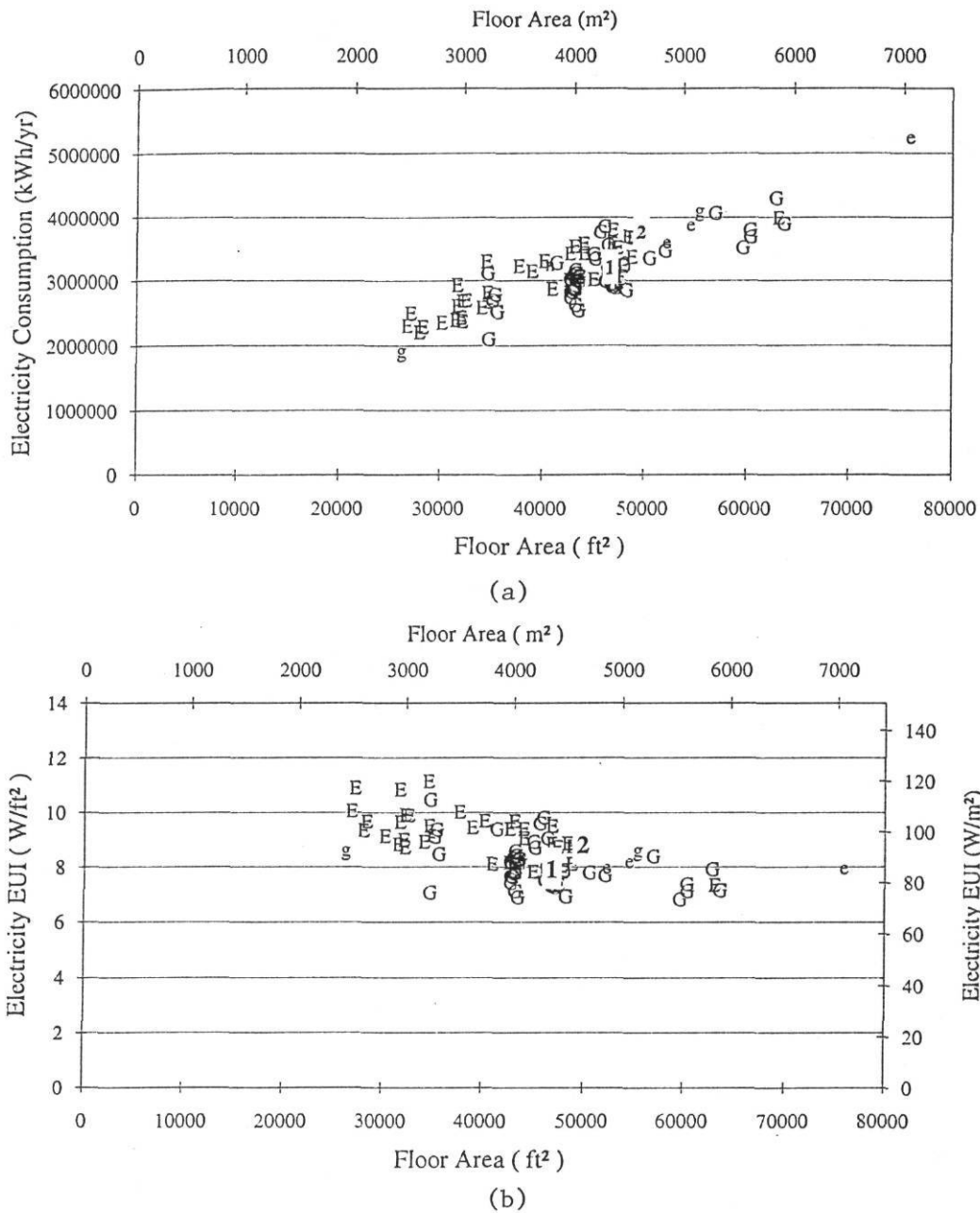
It was initially thought that the latent load on the stores' air-conditioning systems would be a significant determinant of the electricity consumption, and therefore easy to determine either statistically or graphically. Unfortunately, a significant influence was not readily apparent using a climate index based on wet-bulb degree hours and annual electricity consumption. This can be seen when the whole-building electricity EUI is plotted against the climatic index (see Figure 2.4a).

Stores in the more humid zones (i.e., zones 5+) tended to show only slightly greater EUIs than those in the dryer zones. While this may well be due to an increased latent air-conditioning load in the more humid climates, the increase only represents on average about 1 W/ft<sup>2</sup> (10.76 W/m<sup>2</sup>) which is 11 % of the average EUI value. Also, since this climate index considers only wet-bulb temperature, stores closer to the Gulf of Mexico may not be represented as well as they could be with a dry-bulb temperature index because they may have higher latent loads yet lower outside dry-bulb temperatures than stores which are farther inland where temperatures are higher and latent loads are lower. The counteractive effect between wet-bulb and dry-bulb temperatures in this region may mask the influence of either dry-bulb or wet-bulb when considered separately. Constant lighting and miscellaneous loads may also make it difficult to see a climate effect when only annual whole-building EUIs are available.

In Figure 2.4, a more significant trend can be seen in the plot of gas use versus climate index. Stores in the drier, northern zones (zones 1 to 3) tended to have higher gas EUIs (Btu/m<sup>2</sup>-yr) than do the other stores. Stores in the more humid zones (higher

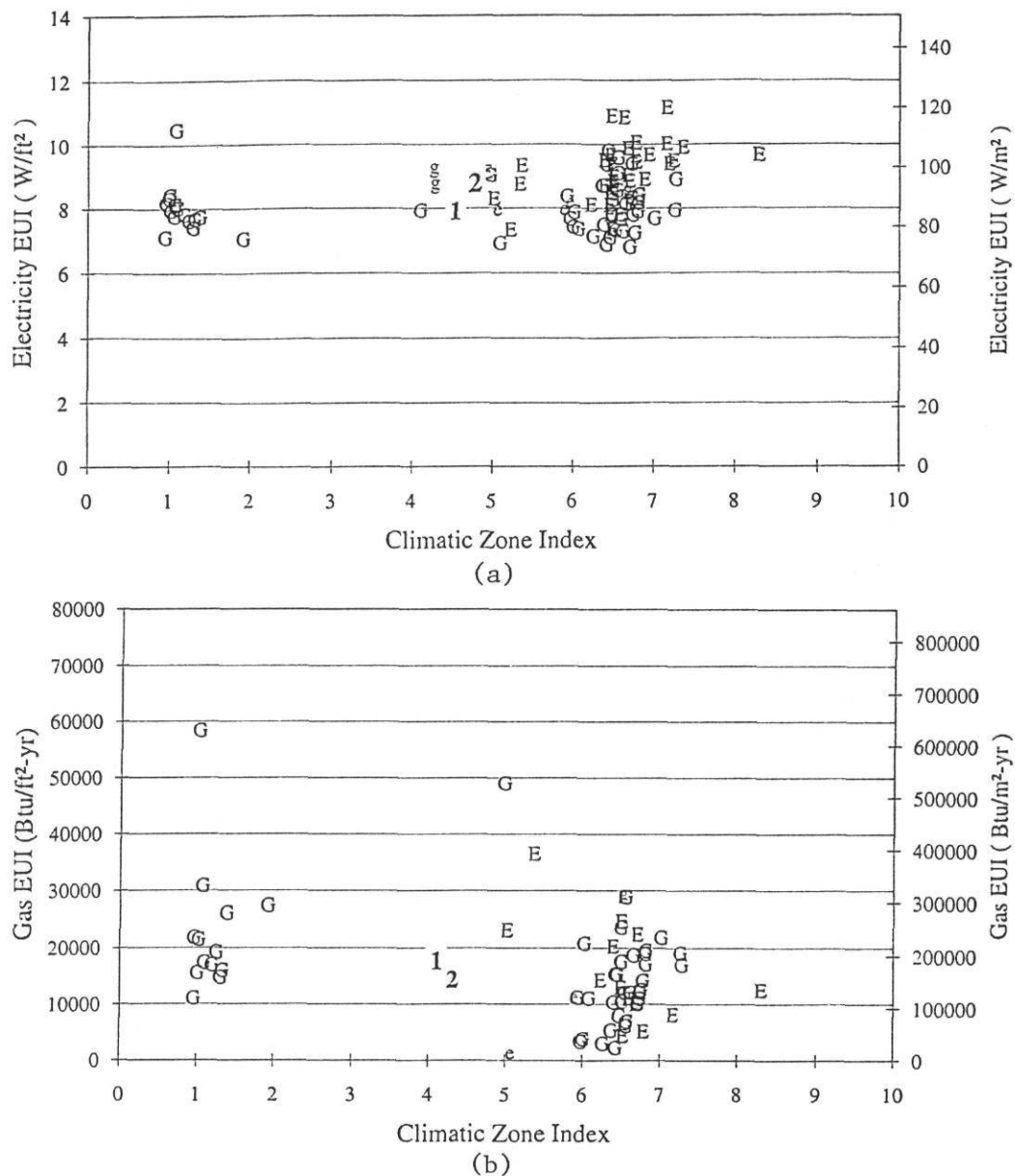
---

<sup>2</sup> The EIA reported an average of 4.3 W/ft<sup>2</sup>.



**Figure 2.3 a,b**

*Electricity Consumption and Electricity EUI vs. Floor Area. An increase can be seen in electricity consumption as floor area increases. Stores tended to have an electricity EUI of roughly  $9 W/ft^2$  ( $96.9 W/m^2$ ), and varied to extremes by  $\pm 2 W/ft^2$  ( $\pm 21.5 W/m^2$ ). These values differ from those presented by EIA (1986) by an average of 100%.*

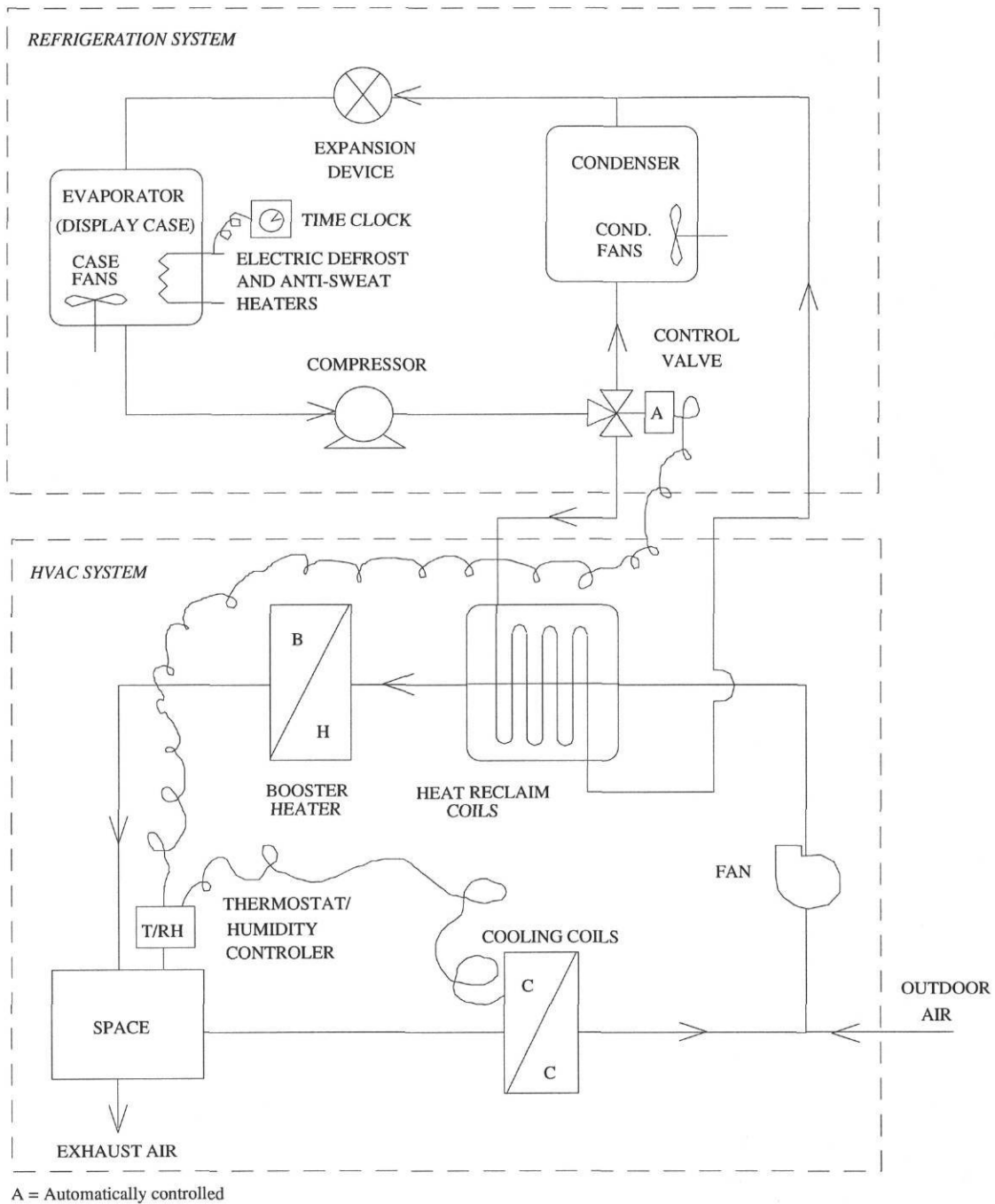


**Figure 2.4 a,b**

*Electricity and Natural Gas EUIs vs. Climatic Zone Index.*

*A significant influence was not readily apparent using a climate index based on wet-bulb degree hours and annual electricity consumption. A more significant trend can be seen in the plot of gas EUI versus climate index. Stores in the drier, northern zones (zones 1 to 3) have higher gas EUIs than do the other stores.*





**Figure 2.5** Heat Reclaim System Schematic.

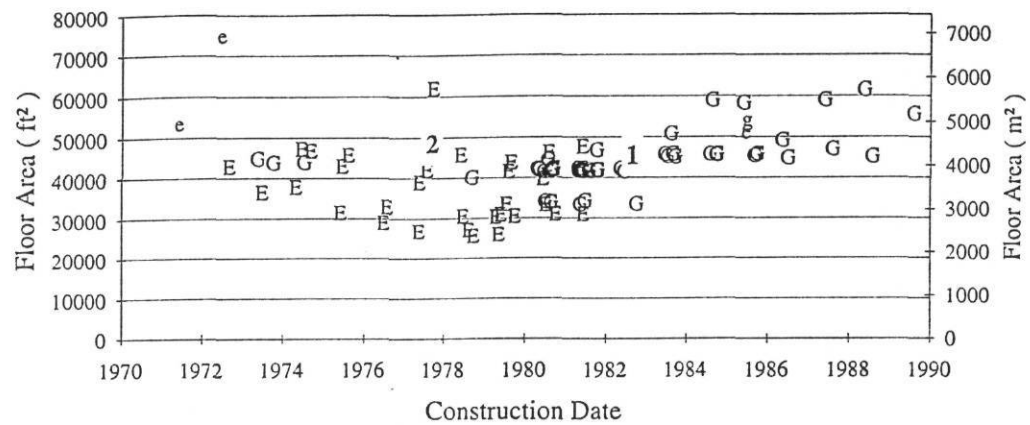
zone indices) tended to show only slightly greater electricity EUIs (annual, averaged  $W/m^2$ ) than those in the dryer zones. The College Station store (store 1 in Figure 2.4) has a slightly higher natural gas use per unit floor area than the Bryan store. As will be noted later in Chapter 3, although the College Station store used about 100 million Btu per year more than the Bryan store in 1990, the Bryan store has the higher *peak* gas consumption in the heating season. This makes sense since the Bryan store uses its gas for heating instead of cooking.

All but six of the stores used waste heat recovered from the condensers of the refrigeration system to provide space heating. These stores were equipped with either gas-fired or electric booster heat for use when the reclaim heat was not adequate. Seventy-six stores use reheat for dehumidification. Figure 2.5 shows a typical heat reclamation system installed in many stores. Heat is extracted from the condensing units of the refrigeration system, and used for space heating. According to discussions with the facilities engineer, stores in zones 4 to 7 only called for gas booster heat about 1% of the time (or less); the majority of their gas usage went to cooking. Stores in the more inland regions (zones 1 and 2) made significant use of their booster heating, which accounted for their greater gas usage compared to stores in other zones.

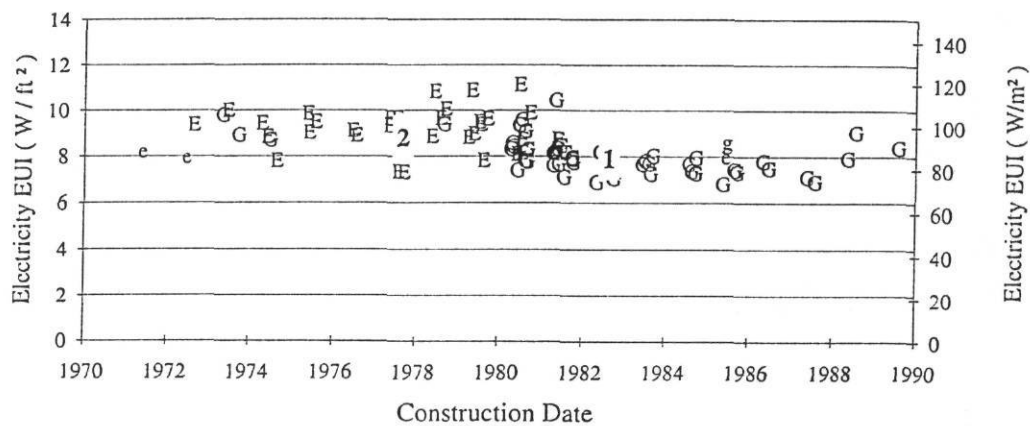
As shown in Figure 2.6a, stores built by the corporation after about 1979 are larger than those built prior to that year ("construction date" actually refers to the date each store was acquired and/or built). As shown in Figure 2.6b, post-1979 stores use less electricity per  $ft^2$ , due in part to the use of heat reclaim from the refrigeration compressors and natural gas booster heat for space heating. These buildings were built to new corporate engineering specifications. An appreciable decrease in electricity EUI ( $W/m^2$ ) is seen after 1979, which corresponds to the beginning of a new energy conservation policy. New stores average  $8.3 W/ft^2$  ( $89 W/m^2$ ), while older stores average  $9.1 W/ft^2$  ( $98 W/m^2$ ), a difference of about 9%. As shown in Figure 2.6c, stores using gas, built after about 1983, tend to use less gas per unit area as well.

Typical energy-saving measures employed since 1979 by this grocery store chain include:

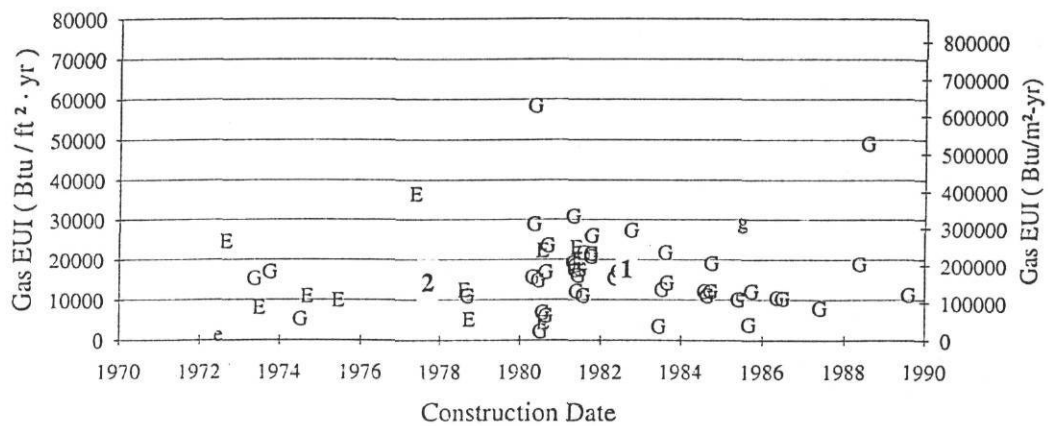
- 1) better insulation (an R-4 increase),
- 2) the changeover from incandescent to fluorescent lamps,
- 3) installation of energy-efficient ballasts on fluorescent lamps,
- 4) the changeover from electric to gas-fired booster heating,  
(or elimination of booster heating altogether),
- 5) better sealing of building entrances using vestibules.



(a)



(b)



(c)

Figure 2.6 a,b,c Floor Area, Electricity and Natural Gas EUIs vs. Construction Date.

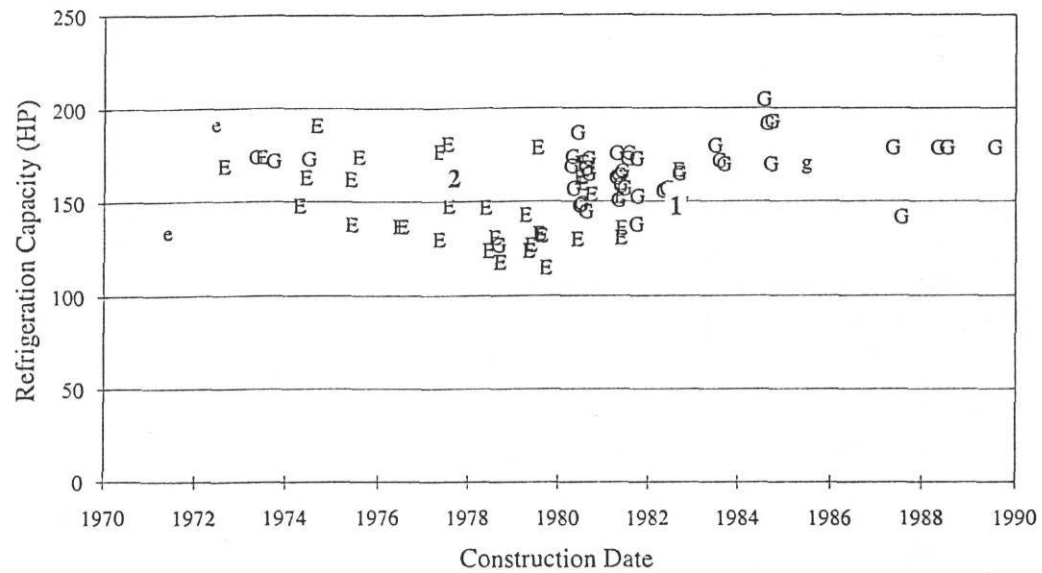
In addition, an effort was made to ensure that buildings were built to the new corporate design specifications.

It was thought that the lack of electric heating in gas-boosted stores explained their lower electricity consumption. However, discussions with the chief facilities engineer of the store chain revealed that stores using heat reclaim from the compressors (92% of the stores) rarely needed booster heat whether it be gas or electric. It is estimated that electric booster heating is needed about two days per year, if at all. And indeed, at the case-study store located 100 miles northwest of Houston, the fraction of booster heat time is only 1% of the HVAC system's operating hours (Schrock, 1989). According to the chief facilities engineer, booster heating is no longer installed in new stores built between climatic zone 6 and the Gulf coast. Thus, since booster heating is so rarely used, it is unlikely that the absence of electric heat in gas-boosted stores is the primary cause of the reduction in their electricity consumption.

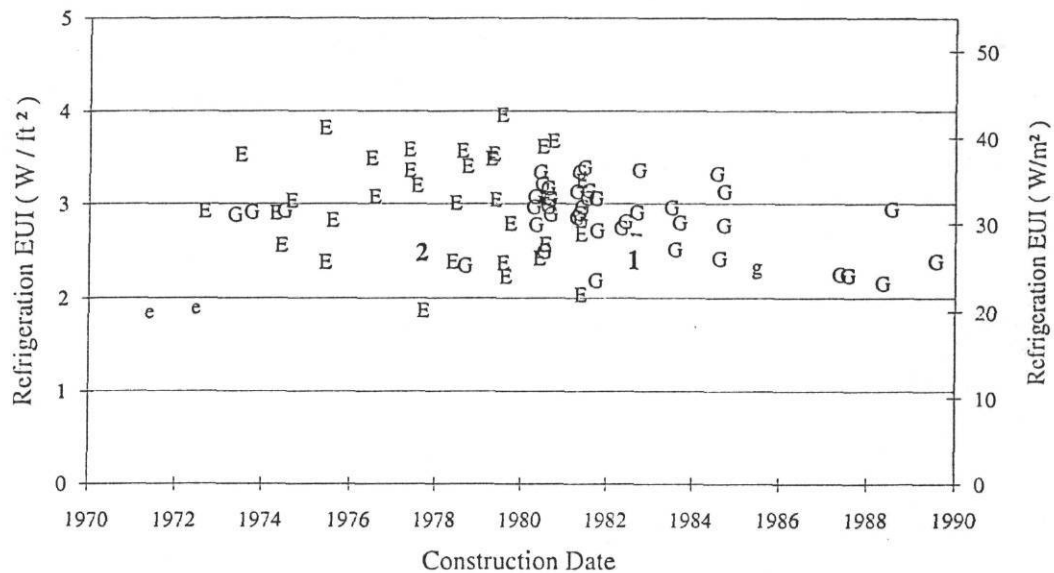
Figure 2.7a shows that there has been only a slight variation in the installed refrigeration capacity over the last twenty years. The variation tended to follow the same pattern as store size. As shown in Figure 2.7b, the refrigeration nameplate EUI ( $\text{W}/\text{m}^2$ ) has been fairly constant over the years, though a slight decrease is seen after about 1983. This corresponds to the point at which the corporation began to build larger stores which stock a considerable amount of dry merchandise that does not require refrigeration.

Discussions with the stores' engineering personnel have revealed other possible reasons for the trends that are displayed in Figure 2.8. Even the smaller stores seemed to have a minimum amount of refrigeration, roughly 100 to 150 hp. As the stores become larger, refrigeration capacity increases. But there seems to be an upper limit to the capacity. When store size reaches about 50,000  $\text{ft}^2$  (4,600 to 5,600  $\text{m}^2$ ), the capacity-floor area curve appears to level off, indicating that additional refrigeration capacity is not being added to service the additional floor area.

While whole-building energy consumption, floor size, and construction date tell us general characteristics about the store buildings, specific information is difficult to glean from the data without a detailed knowledge of the equipment in the store. The



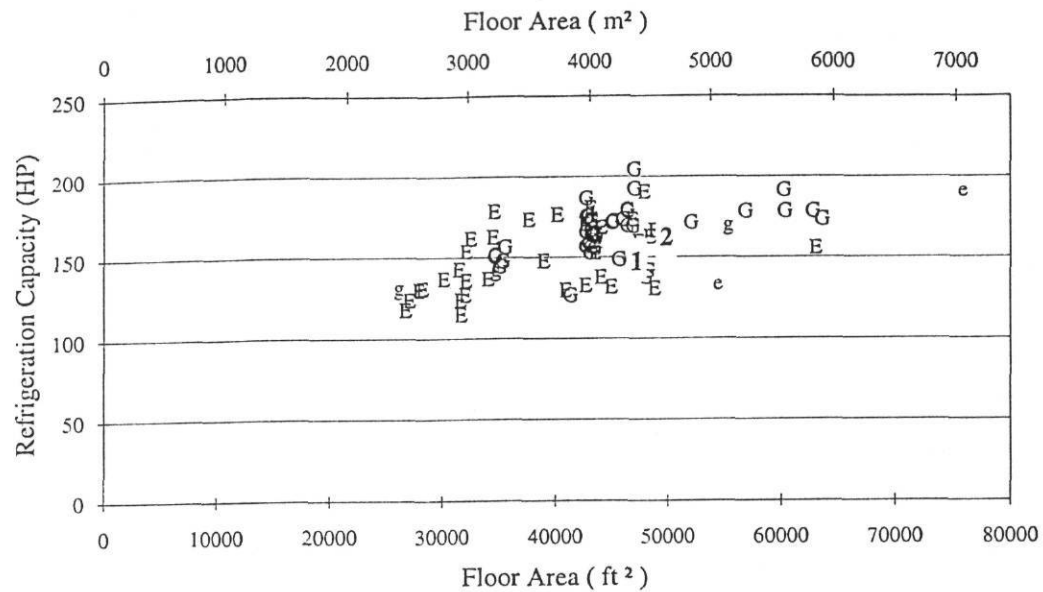
(a)



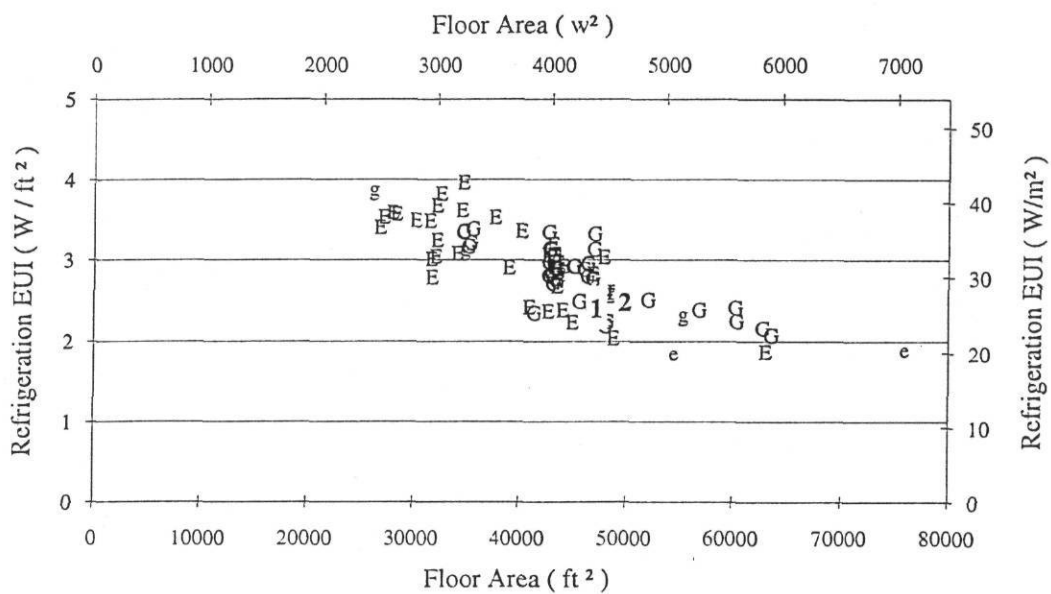
(b)

**Figure 2.7 a,b**

*Nameplate Refrigeration Capacity and Refrigeration EUI vs. Construction Date. Variation in installed refrigeration capacity tended to follow the same pattern as store size. Refrigeration nameplate EUI has been fairly constant over the years, though a slight decrease is seen after about 1983, when the corporation began to build larger stores which stock a considerable amount of dry merchandise that does not require refrigeration.*



(a)



(b)

**Figure 2.8 a,b**

*Nameplate Refrigeration Capacity and Refrigeration EUI vs. Floor Area. As the stores become larger, refrigeration capacity increases. But when store size reaches about 50,000 ft<sup>2</sup> (4,600 to 5,600 m<sup>2</sup>), the capacity-floor area curve levels off, indicating that additional refrigeration capacity is not being added to service the additional floor area.*

energy-using components of a store do not all share the same characteristics with respect to floor area. While some components, such as air-conditioning and lighting, are intuitively functions of floor area, refrigeration capacity and other miscellaneous loads may not be.

### 2.3 SUMMARY

The survey of the 93 grocery stores in south-Texas showed that there is much that can be learned about energy use in grocery stores using annual EUIs and information which can be gleaned from a mail-in survey. The following specific points were made:

- 1) Total electricity EUI is an average of about 9 W/ft<sup>2</sup> (96.9 W/m<sup>2</sup>), and varies to extremes by  $\pm 2$  W/ft<sup>2</sup> ( $\pm 21.5$  W/m<sup>2</sup>). Stores smaller than 40,000 ft<sup>2</sup> had an average overall EUI of  $9.5 \pm 1.7$  W/ft<sup>2</sup>, while stores larger than 50,000 ft<sup>2</sup> had an average EUI of  $7.7 \pm 1.1$  W/ft<sup>2</sup>. Stores between 40,000 and 50,000 ft<sup>2</sup> had an average EUI of  $8.2 \pm 1.4$  W/ft<sup>2</sup>.
- 2) Annual electricity consumption in 1990 ranged from about 1.5 to 6.0 GWh/yr (million kWh/yr), with 70% of the stores consuming between 2.7 and 3.7 GWh/yr. Of the 68 stores using natural gas, approximately 70% consumed between 300 and 1,000 million Btu/yr.
- 3) With most of the stores in the same geographic area, it seems unlikely that variations in climate-dependent loads explain the trend in EUI. Rather, this seems to be due to component loads which do not increase as store size increases. The largest such load is refrigeration.
- 4) Stores built after 1979 have roughly 9% less energy consumption per square foot than those built before 1979. This is due to at least two reasons.
  - a) Stores built after 1979 were larger. These stores used their additional space to stock merchandise that did not require refrigeration.
  - b) Stores built after 1979 included a significant number of energy-saving measures.
- 5) In the south-Texas region, heat reclamation from the refrigeration systems provides an adequate means of space heating for most winter-time conditions.

However, there is a limit to what may be learned from general surveys. The two case study stores, described in the next chapter, represent about 70% of the 93 stores in the survey with respect to their building characteristics and energy use. In general, grocery store energy use is divisible into components. Because only some of these components are dependent upon store size and/or climate, a more detailed analysis involving sub-metering of energy use is required in order to determine key predictors of energy use for a particular store. Nevertheless, the database section of the project provides a good foundation on which to apply the results of the findings in the case study.



## CHAPTER III

### CASE STUDY

The sections that follow describe the two case study grocery stores. First, the College Station store will be discussed, followed by the Bryan store. General building characteristics are given, followed by a description of the major energy-using equipment in each store. Both stores are located approximately 100 miles northwest of Houston, Texas, in the cities of College Station and Bryan, Texas. The 1% mean dry bulb temperature for this area is 98°F (37°C), with a coincident wet bulb of 76°F (25°C). The location has 1786 annual heating degree-days and 2806 annual cooling degree-days (19°C [65°F] base) (Schrock 1989).

#### 3.1 BUILDING STRUCTURE OF COLLEGE STATION STORE

The first case study grocery store is located in a medium-sized shopping plaza. Customer parking is available at the front of the store, while deliveries are made at the rear of the store. Adjacent to the store is a video tape rental store, also run by the grocery store management. Both stores share one interior wall, and are flanked by other adjacent, air-conditioned buildings.

For the grocery store portion of the building, the exterior northwest and southeast walls are constructed of 6-inch (0.15-m), poured concrete, and have 3.5 inches (0.09 m) of batt insulation behind interior dry-wall. The northeast and southwest walls are 160 feet (50 m) and 250 feet (76 m) long, respectively, and 20 feet (6.1 m) high. The northeast wall has a 60-ft by 16-ft (18-m by 5-m) glass section which serves as the entrance to the store and includes a double-doored enclosure with automatic doors. The roof is constructed of a metal deck which supports a 1.5-inch (0.04-m) layer of styrofoam insulation, a 2-inch (0.05) concrete slab, and a built-up roof covered with light-colored aggregate. A plan view of the store is shown in Figure 3.1.

The building is a single-story structure with 16-foot (4.9-m) drop ceilings and a total area of 46,000 ft<sup>2</sup> (4,300 m<sup>2</sup>). The front 35,000 ft<sup>2</sup> (3,300 m<sup>2</sup>) of floor area is used for product display, and the rear 11,000 ft<sup>2</sup> (1,000 m<sup>2</sup>) holds the space-conditioning

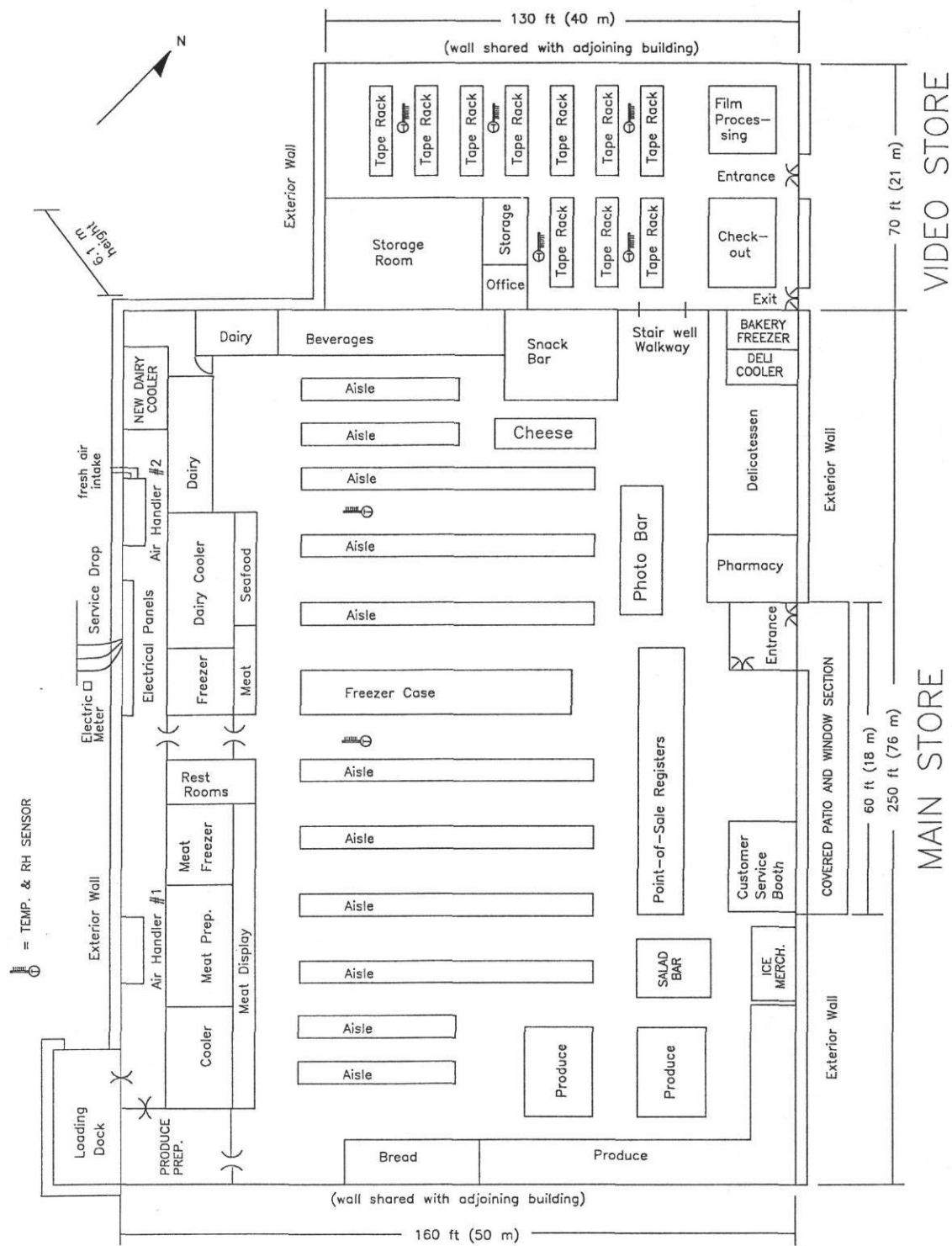


Figure 3.1 Plan view of the College Station grocery and video stores.

equipment, walk-in coolers and freezers, and the meat preparation areas. The store contains a 500-ft<sup>2</sup> (46-m<sup>2</sup>) office space located above the pharmacy and delicatessen, and a 150-ft<sup>2</sup> (14-m<sup>2</sup>) mechanical room located above the rest rooms in the rear of the store (Schrock and Claridge, 1989). Pictures of the inside and outside of the store, and the components therein, can be found in Appendix F.

The video tape rental store is accessible from the northwestern wall of the grocery store, and has 9,100 ft<sup>2</sup> (845 m<sup>2</sup>) of display space with 10-ft (3-m) ceilings. The northeastern wall is a 21-m by 3-m (70-ft by 10-ft) glass and dry-wall section. The entrances to the store are double swinging doors without vestibules.

## **3.2 MAJOR ELECTRICAL EQUIPMENT OF COLLEGE STATION STORE**

This section describes the major energy-using equipment in the College Station store. The information was gathered during walk-through surveys, and consists of nameplate readings and selected clamp-on power readings (where possible). All equipment in the College Station store runs at 120 VAC (1-phase) and 208 VAC (3-phase). A detailed listing of the loads can be found in Appendix B of this thesis.

### **3.2.1 Refrigeration Equipment**

Twenty-three single-mounted compressors units are used to cool the refrigeration/freezer cases and coolers in the facility. Fifteen use refrigerant R12, and eight use refrigerant R502. The total compressor nameplate capacity is 166 hp, or 124 kW input. Condenser fans comprise an additional nameplate load of 8.5 kW. The electric resistance defrost heaters have a total nameplate load of 71 kW.

Including the condenser fans, the measured, connected compressor system load is roughly 138 kW during non-defrost operation. Some display cases use hot gas defrost provided by the compressors.<sup>1</sup> Others use electric resistance heaters for this purpose. A high load of 156 kW was measured during defrost cycles, implying an electric resistance defrost cycle load of 18 kW. Time clocks control the compressor defrost cycles. The defrost cycles last up to one hour or until the cooling coils reach 70°F (21°C). The compressors are summarized as follows in Table 3.1.

Ambient air is circulated through the compressor room by four 6-hp fans which have a total nameplate load of 22 kW. These fans come on in stages

---

<sup>1</sup> During hot gas defrost, the compressors operate in a reverse cycle, acting as heat pumps. Hot refrigerant is pumped through the display case evaporator coils. This melts any ice that may have accumulated on the coils.

TABLE 3.1  
Refrigeration Compressor Summary for College Station

Load Served	Refrigerant	Rated HP	Measured kW	Measured kW with defrost*
Meat W.I. COOLER	R12	5	5.58	5.58
Meat Prep W.I. COOLER	R12	5	5.22	5.22
Flrl/Deli/Beer W.I. COOLER	R12	10	8.38	8.38
Bkry & Groc W.I. FRZR	R502	9	8.29	8.29
Produce Prep W.I. COOLER	R12	5	5.94	5.94
Nutrit/Seafd W.I. COOLER	R502	3.1	2.25	2.25
28' 3-Deck Meat COOLER	R12	7.6	5.67	5.67
20' LnchMeat Case COOLER	R12	5	5.04	5.04
32' LnchMeat/Deli COOLER	R12	7.65	6.85	6.85
End Cap FRZR	R502	5	3.78	4.14
68' Coffin FRZR	R502	7.6	5.85	10.72
68' Coffin FRZR	R502	7.6	5.58	10.54
68' Coffin FRZR	R502	7.6	5.76	10.72
68' Coffin FRZR	R502	7.6	5.49	10.18
10' Glass Door Ice Crm FRZR	R502	15	8.92	7.93
84' Produce COOLER	R12	10	8.56	8.56
64' Island Produce COOLER	R12	5	4.05	4.05
44' Chz & Butter COOLER	R12	10	8.74	8.74
36' Dairy COOLER	R12	7.6	7.48	7.48
Meat & Cheese COOLERS	R12	7.6	6.57	6.57
Deli COOLER	R12	3.1	2.07	2.07
Dairy Case Top #1	R12	7.6	5.58	5.58
Dairy Case Top #2	R12	7.6	5.94	5.94
<b>Total:</b>		<b>166 hp</b>	<b>137.6 kW</b>	<b>156.5 kW</b>

\* Hot gas defrost. Some display cases use electric heaters for defrost. Electric heater loads, not included here, are part of the Miscellaneous Utility loads (see below).

beginning when the temperature difference across the condenser coils is about 8°F (4°C), and stop when the compressor room ambient temperature is less than about 60°F (16°C)<sup>2</sup>.

The peak connected load of the compressor and exhaust fan system, based on measured loads, is 160 kW under normal operation, and 178 kW during coincident defrost periods.<sup>3</sup> The peak load based on nameplate information is 155 kW during non-defrost periods, and 226 kW during coincident defrost periods.

Sixteen groups of refrigeration/freezer cases (about 60 separate case units) display the food, with one compressor dedicated to each group. Six walk-in storage coolers and freezers are located in the store's back rooms, and are cooled by the remaining seven compressors. The case fans, glass door anti-sweat heaters, and lighting are connected to the utility and lighting circuits of the store. See Utility and Lighting sections below for more information.

### 3.2.2 HVAC Equipment

The store has two 50-ton air-conditioning systems, which each have two 43-hp compressors and one 15-hp fan which circulates air at 18,000 CFM (manufacturer's data).<sup>4</sup> The maximum nameplate load of both air-conditioning units is 170 kW. Based on this information, the nameplate EER rating of the combined system is 7.1 Btu/W·h. This implies a coefficient of performance (COP) of 2.08. On one of the units, 290 CFM (measured) of outside air are brought into the store through a passive ducting system.<sup>5</sup>

From clamp-on measurements, the blower fan in each air-handling unit draws about 43 amps per phase. At a voltage of 208 VAC, this amounts to about 14 kW. During second-stage cooling, the compressors on each air-handler draw as much as 184 amps per phase, amounting to 58 kW. Thus, the maximum load for both air-

---

<sup>2</sup> This could be one of the reasons for the change-point behavior seen in the sub-metered refrigeration system energy use. The change-point temperature is about 62°F (17°C).

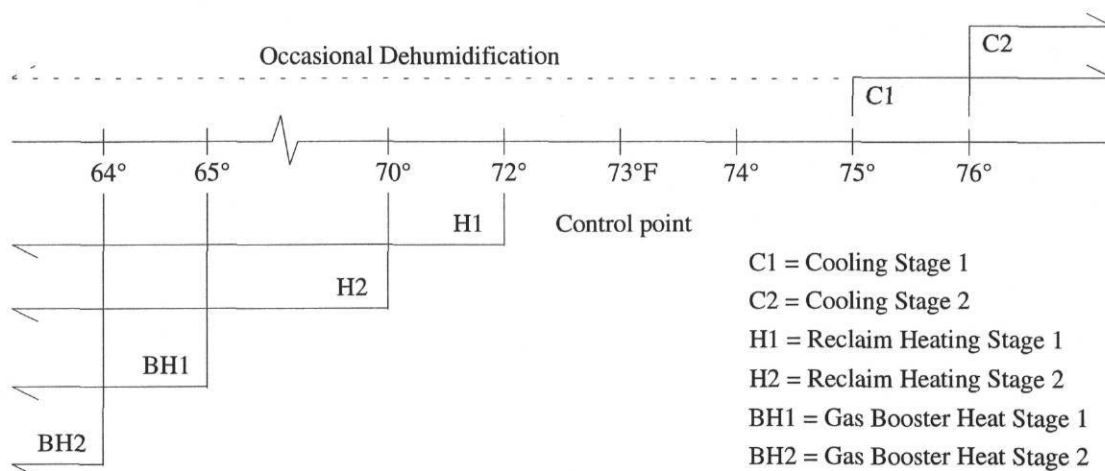
<sup>3</sup> These values are consistent with those obtained through electrical sub-metering, which vary with ambient outdoor temperature from about 70 to 170 kW.

<sup>4</sup> An estimated power factor of 0.88 (ratio of kW to kVA) and mechanical efficiency of 0.90 were taken from tables provided by Turner (1982) and used to determine the maximum load of each compressor and fan based on nameplate amps and horsepower.

<sup>5</sup> The store management is aware that this is an undesirably low fresh air ventilation rate. There is an unquantifiable amount of outdoor air which enters the store through doors and the loading dock, and leaves through exhaust ducts.

handlers observed during walk-through surveys is 144 kW. This is 85% of the nameplate load.

Each air-handler unit has its own controller which controls the heating or cooling stage based on indoor dry-bulb temperature and relative humidity sensors. The store set point is 75°F (24°C) dry-bulb, and 55°F (13°C) wet-bulb. Figure 3.2 shows a schematic of the temperature conditions for which the various stages of cooling and heating are controlled.



**Figure 3.2**

*Schematic of the indoor temperature conditions HVAC system control. This figure shows the indoor temperatures for which the various stages of cooling, heating, and dehumidification are controlled. Dehumidification is handled by one stage of cooling only. The control point may be varied by  $\pm 2^\circ\text{F}$ .*

Cooling stage 1 uses one compressor; stage 2 uses both compressors. Heating stage 1 uses half of the heat reclaim capacity available to the air-handler unit; heating stage 2 uses all available heat reclaim capacity. Likewise, there are two stages of gas booster heating from furnaces installed in the air ducts down stream of the heat reclaim coils. Figure 3.3 shows the HVAC system control curves.<sup>6</sup> The two main HVAC units each have their own temperature/relative humidity controller, and are set to operate at, or below, curve *B*. The humidity controller activates one stage of cooling upon

<sup>6</sup> These curves were transcribed from the specifications inside the thermostat box, model number H609A manufactured by Honeywell, Minneapolis, MN, 55422.

determining a rising dew-point temperature, thus reducing the moisture content of the air. Return air conditions, monitored since November, 1992, reveal that the HVAC system is keeping return air conditions at or below the control curve *B*, and between 15° and 24°C (58° and 74°F) dry-bulb, 25 and 55% relative humidity (which is between -1° and 10°C [30° and 50°F] dew-point).

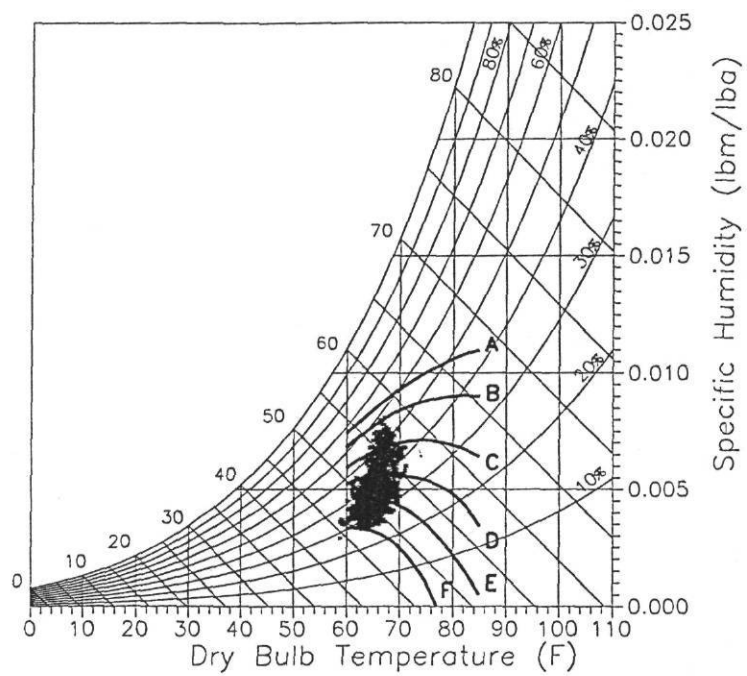
Figure 3.4 shows these data for four modes of HVAC system operation -- cooling only, heating only, dehumidification (heating and one stage of cooling), and fans only. We determined from the sub-metered HVAC data when the fan and cooling stages were operating. Duct air temperatures were monitored with battery-operated temperature recorders for about three months. The cold-deck, hot-deck, and return air temperatures were the three points which were monitored. This made it possible to determine when the heating coils were being used. With this information, we determined when any of the four modes of HVAC operation were in effect.

Heat recovery from the refrigeration system is used to provide heat during the first two stages of heating. A third and fourth stage of booster heating is available from natural gas duct heaters which have a capacity of 125 million Btu/hr (nameplate). However, the gas booster heating has been used only 1% of the time the store has been in operation. This is consistent with the findings of ORNL (DOE 1981 p. 1-16), which state that "[in] 1979, 96 percent of new stores had installed heat reclaim units . . . . Even in northern climates, properly designed heat reclaim units can provide all the necessary space heating requirements."

Three 7.5-ton, and two 5-ton roof-top HVAC units serve the video store which is located next to the main store. Three of these units draw their power from the main store's HVAC electricity circuit. The remaining two -- two of the 7.5-ton units -- are connected to the main store's refrigeration circuit, and therefore are monitored separately from the main store HVAC load. Each of the units are controlled by standard dry-bulb thermostats which have on/off and temperature adjustment switches. During a walk-through survey, the electricity load of these units was measured to be 21.7 kW. The load of the remaining three units was 15.4 kW, although not all were running at full capacity. The total electricity load of the five units was measured to be 37 kW. The peak load based on nameplate data is 44 kW<sup>7</sup>.

---

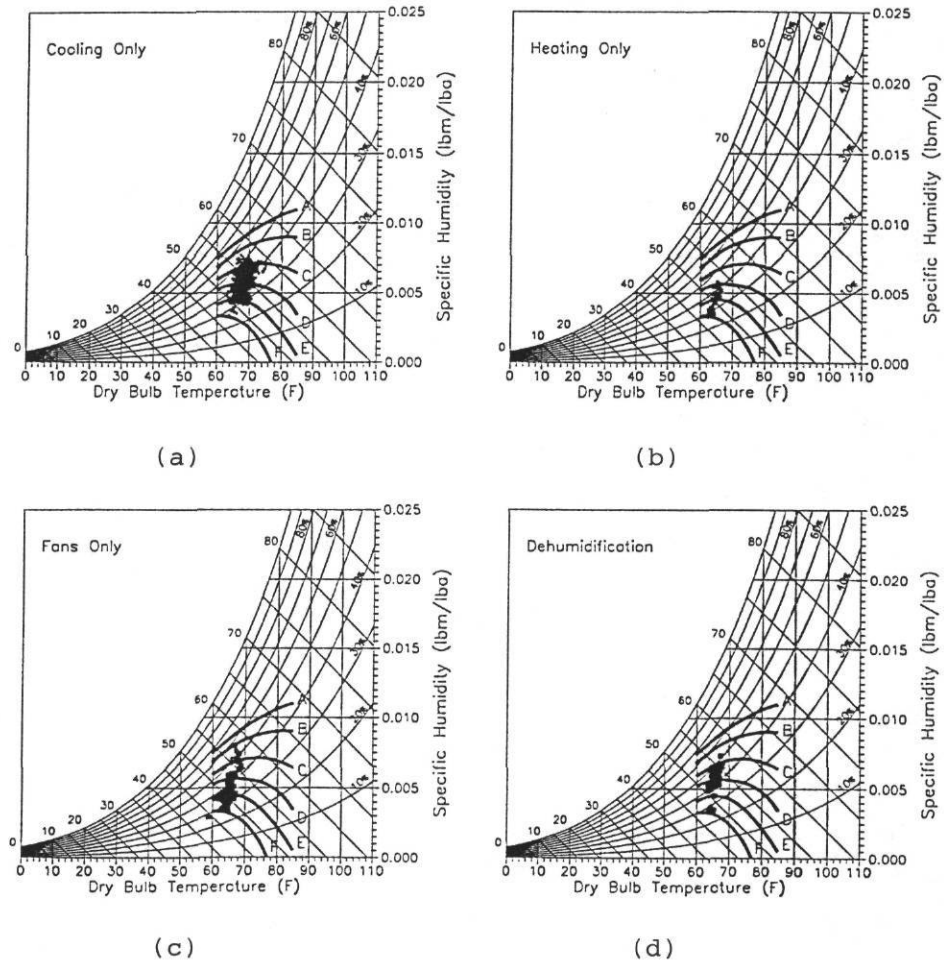
<sup>7</sup> One of the 5-ton units is disconnected due to maintenance problems. It is not included in the load count.



*Figure 3.3*

*HVAC system control curves. The HVAC control thermostat has a range of six control curves (A-F). The system is set near to curve B. Return air conditions are maintained below control curve B.*





**Figure 3.4**

*Four modes of HVAC system operation. (a) Cooling only; (b) heating (heat reclaim) only; (c) fans only; (d) dehumidification (one stage of cooling and heating).*

The measured, combined load of the main and video store HVAC systems during peak times is 181 kW, and the peak nameplate capacity is 214 kW.

### 3.2.3 Lighting

The main store's interior is primarily lit by fluorescent lamps which have nameplate loads ranging from 40 to 100 watts per lamp. Of these, there are approximately 900 overhead lamps in the main sales area (with a total nameplate load of 65.5 kW<sup>8</sup>), 140 overhead lamps for non-sales areas (10.5 kW), 180 refrigerated case lamps and 200 non-refrigerated case and rack lamps (21 kW). See Appendix B for a detailed description of the lights.

About one-half of the sales and back room overhead lights, all bakery lights, and lights on perimeter refrigeration cases are shut off at midnight by the store management. They are turned back on around 8:00 a.m. This is currently done by switching the power off at the electrical panel in the rear of the store. Consideration has been given to controlling these lights with a timer switch. Timers already exist on the lighting electrical panels. Some rewiring would be necessary to affect only the desired lights.

The main store also has 58 metal halide lamps (175 W/lamp) and 17 incandescent lamps (100-W) at various locations. These amount to a connected load of 14 kW. The total connected load of all the lights in the main store is 112 kW including ballasts (nameplate).

The video store has 550 40-W and eight 75-W overhead fluorescent lamps amounting to 30 kW. They are turned on at about 8:00 a.m., and turned off between midnight and 2:00 a.m. when workers in the video store complete their tasks.

The exterior lights, used to illuminate the front and rear parking lots, consist of twenty 1,000-watt high-pressure sodium vapor lamps which have a total connected load of 25 kW (nameplate). The video store has four exterior 400-W high-pressure sodium lamps which illuminate the front of the store. All outside lamps are controlled

---

<sup>8</sup> This includes the ballast watts. The lighting ballast is a small voltage regulation device -- often a small transformer. According to General Electric's Ballast Technical Guide (GE 1986), an average ballast for F40T12, standard and energy-efficient fluorescent lamps increases the lamp circuit wattage by about 10% of the nominal lamp rating. That is, a lamp fixture which houses two 40-watt lamps draws about 88 watts. Thus, a ballast factor of 1.1 is used for all fluorescent lamps in the case study stores. Likewise, ballast factors of 1.2 and 1.25 are used for metal-halide and sodium vapor lamps, respectively. Incandescent lamps do not have ballasts.

by a time clock inside the store.<sup>9</sup> The timer pins are adjusted manually to account for seasonal changes in the length of nights. They are switched on between 5:00 p.m. and 8:00 p.m., and switched off between 6:00 a.m. and 8:00 a.m.

The store has 13 point-of-sale registers throughout the store which have a total connected load of 6.8 kW (nameplate). These are connected to its lighting circuit.

The peak nameplate lighting load for the entire store is 177 kW, including ballasts. Figure 3.5 shows the lighting load profile throughout the day. The daily average lighting load, adjusted for daily lighting schedules, is about 126 kW. The average lighting load measured through sub-metering is 124.7 kW, and the yearly peak is 175 kW, amounting to a diversity factor of 71%. A detailed table of the lighting loads can be found in Appendix B. Three modes of lighting energy use can be seen in Figure 3.5 -- one when half of the in-store lights are off and the parking lights are on, one when all in-store lights are on but outside parking lights are off, and one when in-store and parking lot lights are all on.

### 3.2.4 Miscellaneous Utility

The remaining electrical loads mentioned in this section are listed in detail in Appendix B.

There are 37 pieces of food-processing equipment used for the preparation of meat and deli goods. These items have a total connected load of 109 kW (nameplate) and are used when needed.

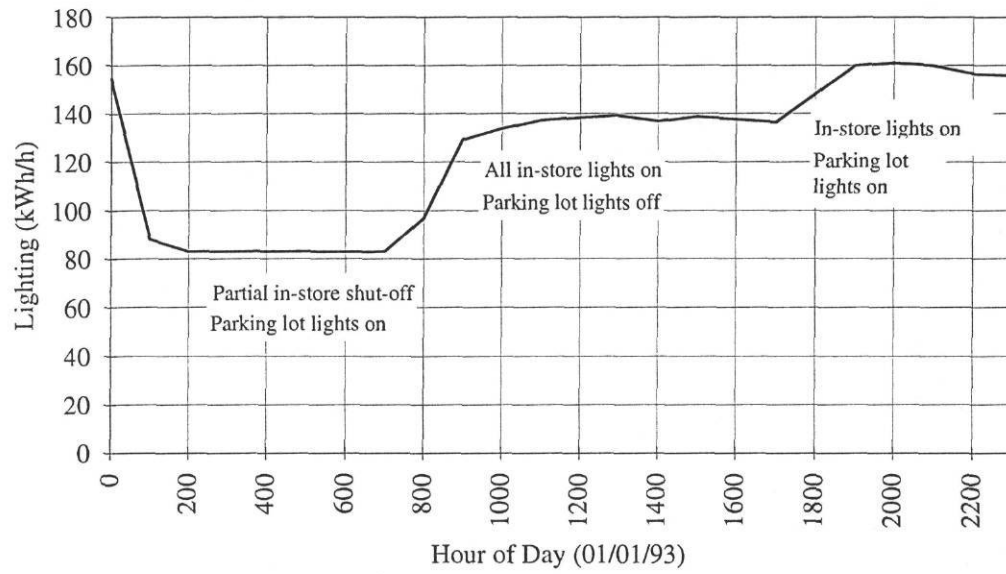
One 10-hp trash baler is located in the loading dock room. At an efficiency of 0.87, its connected load is 8.6 kW.

There are approximately 60 refrigerated display case units. The evaporator fans and anti-sweat heaters<sup>10</sup> of these cases contribute about 27 kW to the miscellaneous utility circuit. Six walk-in coolers and freezers are located in the store's back rooms, which have a total evaporator fan load of 3 kW. Thus, the peak connected nameplate load of the refrigeration case fans and anti-sweat heaters is 30 kW.

---

<sup>9</sup> This timer had malfunctioned occasionally during the summer and fall months of 1991. The operating costs associated with this problem are discussed further in Appendix C.

<sup>10</sup> The anti-sweat heaters prevent condensation from forming on the glass doors and edges of the display cases. They should not be confused with case defrost heaters.



*Figure 3.5*

*Lighting schedule profile for a typical day at the College Station store.*

The total, peak utility load is 148 kW, though this never occurs since all utility loads rarely run at the same time. The average sub-metered utility load is about 76 kW. This amounts to a diversity/load factor of 51%.

### **3.2.5 Natural Gas**

The store uses natural gas primarily for cooking. There are two two-stage gas duct heaters for space heating for the main store, though, as mentioned above, these are rarely used. These have a combined, rated capacity of 840,000 Btu per hour. The roof-top HVAC units on the video store have a combined, rated capacity of 658,000 Btu per hour. The delicatessen has one large natural gas oven which comprises most of the 50 million to 75 million Btu per month base level gas consumption. In the two years since the annexation of the video store, the College Station store used an average of 851 million Btu/yr of natural gas, which amounts to 18,400 Btu/ft<sup>2</sup>·yr.

## **3.3 ELECTRICAL SUB-METERING OF COLLEGE STATION STORE**

The first case-study store had been examined previously by Schrock (1989), who used 15-minute whole-building electricity data transcribed from local utility readings, and Chen (1991), who also used daily whole-building data which had been summed from 15-minute data. For this thesis, a year's worth of hourly sub-metered electricity data and coincident weather data from a nearby weather station (Ruch et al. 1991) were recorded and converted it into an averaged daily format for use with the modeling procedures to be tested.

Four component loads of interest for the combined grocery and video stores were sub-metered. These were:

- 1) refrigeration compressor system loads (compressors, condenser fans, exhaust fans, and defrost heaters)
- 2) lighting loads (exterior, interior, and miscellaneous refrigeration case lighting loads)
- 3) combined store HVAC loads
- 4) miscellaneous utility loads (food preparation equipment, refrigeration case fans and anti-sweat heaters).

Loads were monitored with current and potential transducers, and recorded with a commercially available data-acquisition system.<sup>11</sup> Hourly data were polled on a

---

<sup>11</sup> The data acquisition procedure is described in detail in Appendix A.

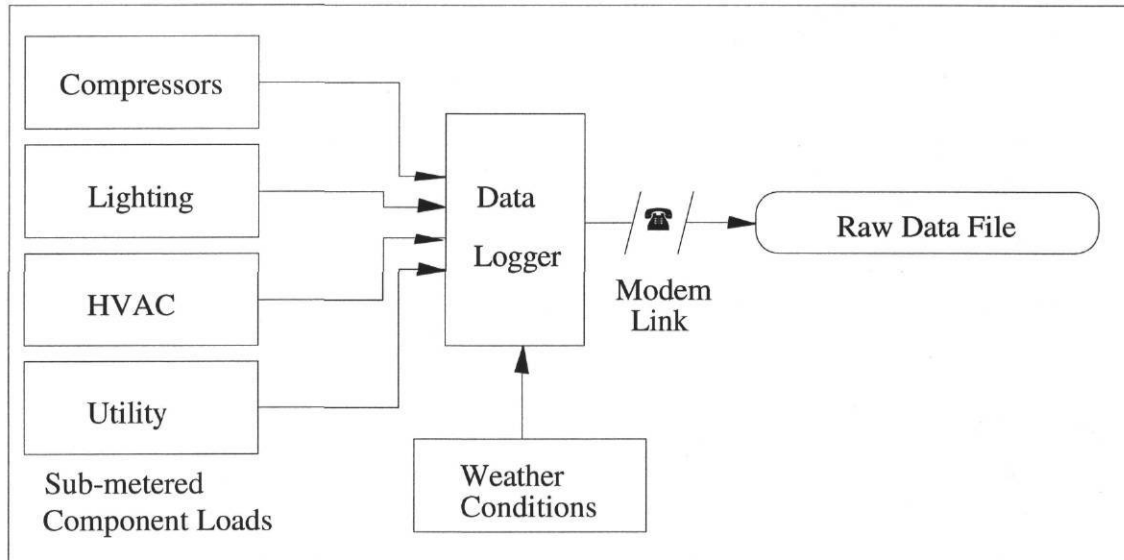
weekly basis, processed into a format readily usable by a statistical computer software package. This procedure is shown graphically in Figure 3.6, and is described in greater detail in Appendix A. The processed data was displayed graphically and reviewed by the project staff on a weekly basis, and by store management, to monitor data quality and to observe and document any anomalies in store operation. Figure 3.7 shows the electrical end-use distribution for the College Station store. The four component loads are divided conveniently into the four main electrical distribution panels of the store. This allowed for ease in monitoring. The only exceptions were two of the video store's 7.5-ton roof-top HVAC units which were connected to the store's refrigeration compressor circuit, and two new 7.6-horsepower dairy cooler compressors which were connected to the store's HVAC circuit.<sup>12</sup>

In the two years since the annexation of the video store, monthly electricity use increased during the summer by about 50,000 kWh/month, and peak demand by about 100 kW. This is shown in Figure 3.8. This increase seems comparable to the sum of the measured video store and new dairy compressor loads, which is 85 kW. The 15-kW difference is most likely due to the photo developing machines and soda display cases in the video store. These loads could not be measured in the walk-through survey. For the past two years since the annexation of the video store, 1991 and 1992, the combined College Station store used an average of 3,610,800 kWh/yr of electricity, amounting to a energy use intensity (EUI) of 7.5 W/ft<sup>2</sup> (81 W/m<sup>2</sup>). This represents a greater energy use than was reported in the 1990 multi-store survey in Chapter 2, because it includes the load of the video store.<sup>13</sup> However, the EUI is less than it was in 1990 since the total store floor area has increased by about 9,100 ft<sup>2</sup>. The store has used an average of 851 million Btu/yr of natural gas, amounting to a gas EUI of 15,400 Btu/ft<sup>2</sup>-yr (166,000 Btu/m<sup>2</sup>-yr). Like the electricity use, the gas use has increased since the annexation of the video store, but the gas EUI has decreased. Figure 3.9 shows the monthly gas use for the store. Natural gas is used by the delicatessen for cooking and by the video store's roof-top HVAC units for heating. The gas use is relatively constant throughout the year except during the months of December to January.

---

<sup>12</sup> The video store HVAC units were sub-metered separately, so that their load could be subtracted off the store's refrigeration load. But, the new dairy compressors were added after the sub-metering was installed; as a result, their load appears as part of the store's HVAC load. However, they amount to less than 10% of the true HVAC load.

<sup>13</sup> The electricity use and EUI in 1990 were 3,215,000 kWh/yr and 8 W/ft<sup>2</sup> (86 W/m<sup>2</sup>), respectively. The natural gas use and EUI were 819 million Btu/yr and 17,700 Btu/ft<sup>2</sup>-yr (191,000 Btu/m<sup>2</sup>-yr).



**Figure 3.6**

*Data Acquisition Procedure.*

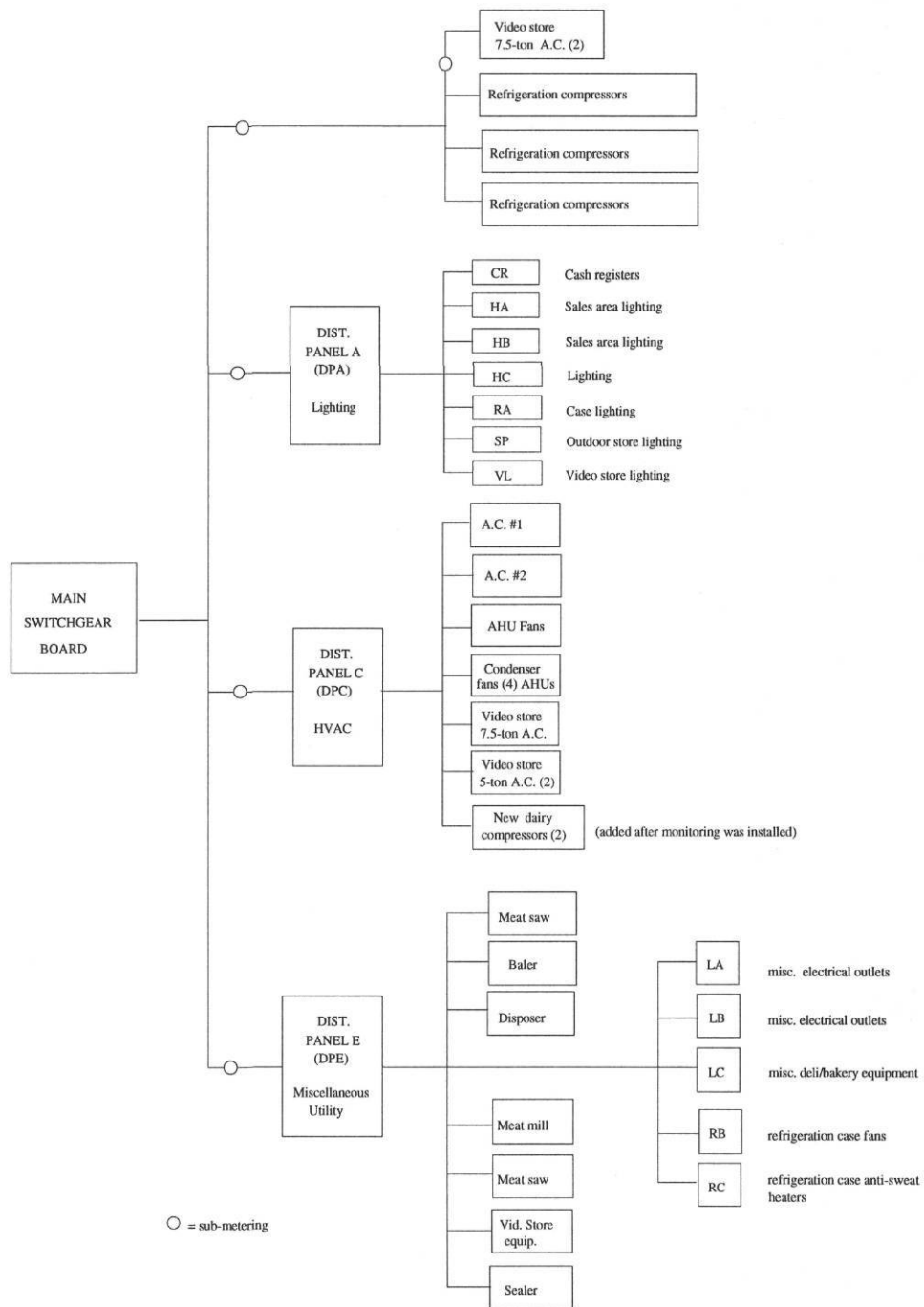
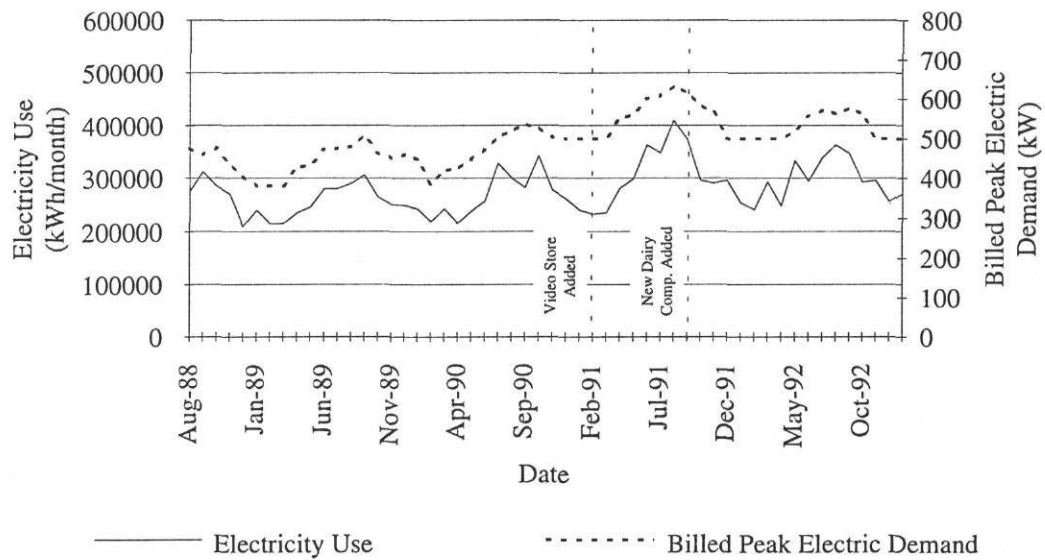


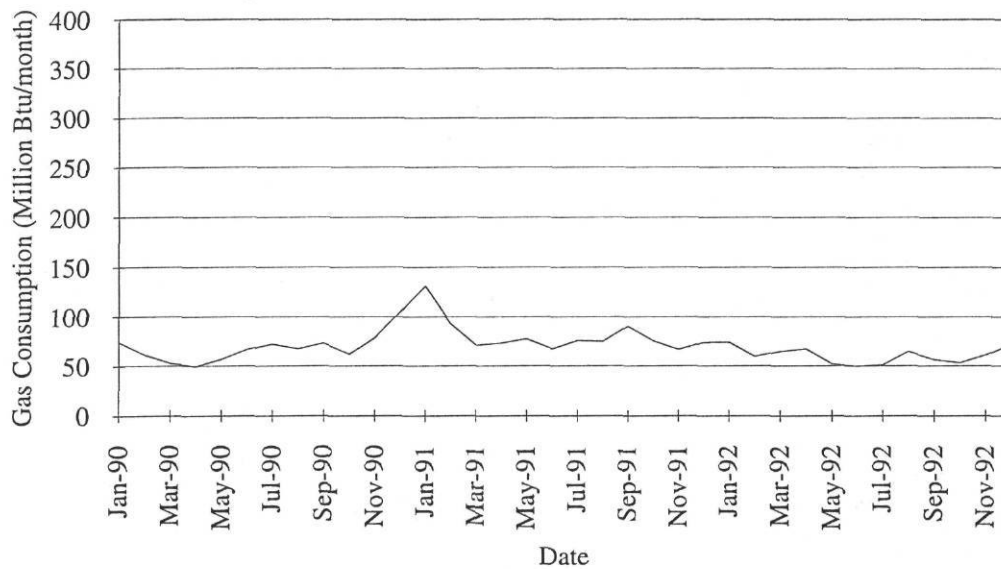
Figure 3.7

Sub-metered electrical circuit in College Station store.





**Figure 3.8** *Historical Monthly Electricity Use from August 1988 to December 1992 for the College Station store.*



**Figure 3.9**

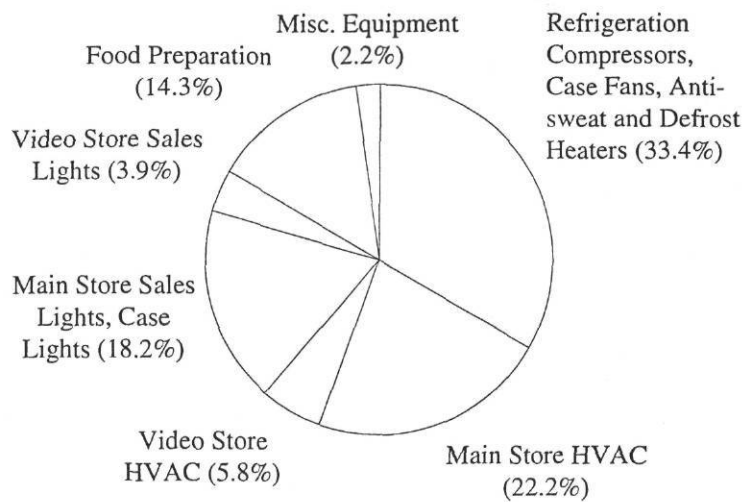
*Monthly natural gas consumption for College Station store. Gas use for 1990 to 1993 varies between 50 million and 130 million Btu per month, though in general it is less than 75 million Btu/month. It is reasonable to assume that at least this much is attributable to cooking use only since it occurs in the summer months.*

Since there is no heating requirement in the remaining months, we assume that natural gas is used primarily for cooking in this store.

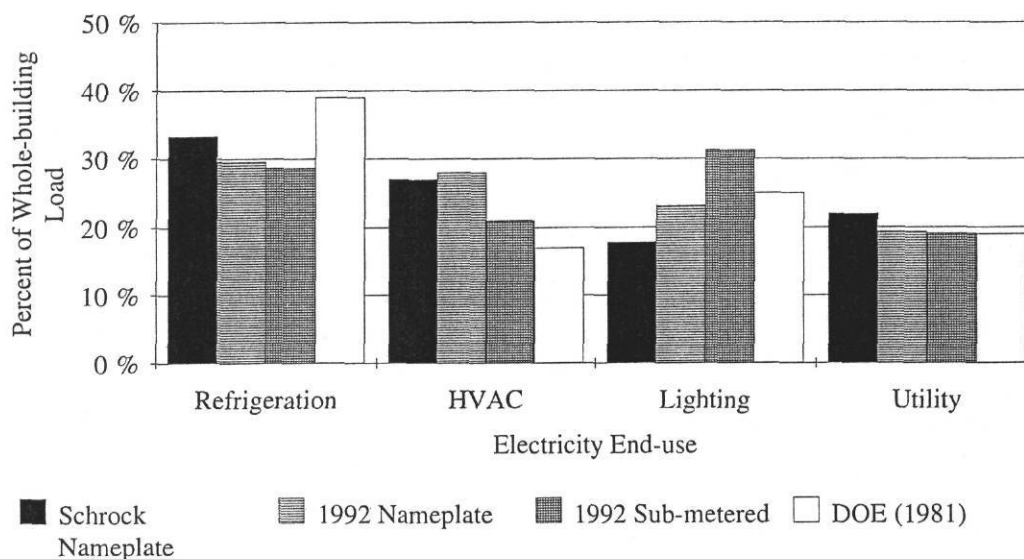
Prior to the annexation of the video store, in an attempt to estimate component loads, Schrock and Claridge (1989) performed an energy load survey based on nameplate ratings of store equipment. Their work was repeated and refined in a new walk-through energy use survey for this thesis. Figure 3.10a and Figure 3.10b show the breakdown of electricity use in the case study store. Figure 3.10a shows the estimated contribution to peak loads based on nameplate power ratings for various end uses. Figure 3.10b shows the contribution of the four main end-use loads as determined from the 1992 survey as well the sub-metered data and from Schrock (1989). The percentages given in DOE (1981) are also included for comparison. Basing the percentages on the nameplate data tends to overestimate the contribution due to HVAC, and underestimate the contribution due to lighting. This is to be expected since the HVAC load varies significantly throughout the year, while loads such as lighting load remain fairly constant. Also, the fact that the HVAC load does not run at full load constantly makes one-time estimation, such as nameplate readings, unreliable. Because of this, peak load estimations cannot represent the true distribution of electricity end use. Both Schrock's thesis and the DOE report estimate a higher contribution due to refrigeration than is seen in either the 1992 nameplate survey data or the sub-metering data. But Schrock's study was performed on the store before the video store was annexed. And, it is assumed that the DOE study also did not include a video store. Because the video store energy use is comprised of only HVAC and lighting, we should not expect the percent contribution due to refrigeration to remain the same after these video store loads were added. Table 3.2 shows a description of the loads included in each breakdown as well as the DOE's percentages.

### **3.4 ENERGY CONSUMPTION DATA FOR COLLEGE STATION STORE**

The usefulness of providing plots energy consumption data on a daily and hourly basis was informally tested by establishing an information loop with the store management. Recorded data were presented in two formats -- weekly summary plots and 3D inspection plots. Ambient hourly weather conditions were provided by a weather station located approximately two miles away. These data were plotted along the top of the summary plot page. This approach gave the store management a chance to keep record of the store processes, and provided the researcher with the kind of data necessary to develop statistical models for predicting the future energy use in the store.



(a)



(b)

**Figure 3.10 a,b**

*Percentages of Nameplate Contribution to Peak and Measured Contribution to Electricity Use for the College Station store. (a) contribution based on nameplate data; (b) Contribution based on Schrock (1989), 1992 nameplate survey, 1992 sub-metered data, and DOE (1981) survey.*

TABLE 3.2  
Description of End-use Loads Included in Group Breakdown  
for the College Station Store

(a) Schrock (1989)	(b) 1992 Survey Nameplate Peak	(c) 1992 Sub-metered	(d) DOE (1981)
<p><b>Compressors</b> (33.3%) Refrigeration compressors, condenser fans.</p> <p><b>HVAC</b> (27.0%) Air-conditioning loads from the two main units.</p> <p><b>Lighting</b> (17.8%) sales area lighting, office, outdoor lights, cash registers, display case lighting.</p> <p><b>Miscellaneous Utility</b> (22.0%) Food preparation and other misc. loads, case fans and anti-sweat heaters.</p>	<p><b>Compressors</b> (29.5%) Refrigeration compressor, condenser and exhaust fans.</p> <p><b>HVAC</b> (28.0%) Air-conditioning loads from the two main units plus video store HVAC.</p> <p><b>Lighting</b> (23.1) sales area lighting, office, outdoor lights, cash registers, display case lighting.</p> <p><b>Miscellaneous Utility</b> (19.3) Food preparation and other misc. loads, case fans and anti-sweat heaters.</p>	<p><b>Compressors</b> (28.6%) Refrigeration compressor, condenser and exhaust fans.</p> <p><b>HVAC</b> (21.0%) Air-conditioning loads from the two main units plus video store HVAC.</p> <p><b>Lighting</b> (31.2%) sales area lighting, office, outdoor lights, cash registers, display case lighting, and some receptacle.</p> <p><b>Miscellaneous Utility</b> (19.1%) Food preparation, misc. receptacle loads, case fans and anti-sweat heaters.</p>	<p><b>Compressors</b> (39.0%) compressors, condensers, case fans.</p> <p><b>HVAC</b> (17.0%) air-conditioning, fans, electric heat.</p> <p><b>Lighting</b> (25.0%) sales area, office, and outdoor sign lights.</p> <p><b>Miscellaneous Utility</b> (19.0%) Unknown</p>

### 3.4.1 Summary Plots and 3D Inspection Plots

An example of the summary plots is shown in Figure 3.11. The four main loads are plotted with respect to both time and temperature. Ambient hourly weather conditions were provided by a weather station located approximately two miles away, and are plotted along the left edge of the summary page.

The 3D plots show loads for the College Station store individually plotted with respect to hour of the day on one axis, and day of the year on the other. This allows the viewer to see not only day-to-day variations in energy use, but also hourly variations. The plots are shown in Figures 3.12 to 3.17 for 1992 data. The hour of day is given in 24-hour time, with midnight corresponding to hour "0".

In the 3D plots, temperature-dependent effects can only be perceived as a month-to-month change. Figures 3.12 (a), 3.13 (a), and 3.15 (a) clearly show a seasonal behavior in the whole-building, refrigeration, and HVAC data. Each load has a minimum during winter months and a maximum during summer months. In Figure 3.13 (b), a series of "rolling waves" appear in the refrigeration system data from hour to hour. Schrock and Claridge (1989) also noticed this effect, and hypothesized that it may be due to defrost timer controls being out of synchronization. They suggested that this might cause several defrost heaters to run at the same time, creating unnecessarily high levels of electric demand. The fact that the waves tend to occur at the same time each day lends support to this hypothesis. Schrock and Claridge, however, did not have sub-metered data, but only whole-building data. The use of sub-metered data clearly revealed the general source of the wave behavior.

A seasonal effect, the variation in day length, can be seen in the lighting load in Figure 3.14 (b). The step in electricity use during the latter portion of the day (between 4 p.m. and 10 p.m.) corresponds to the time at which the parking lot lights are turned on. What is interesting to note is the fact that this step occurs earliest during December and January, when longer nights prevail. The lights are controlled by a timer which is adjusted to account for the change in daylight hours. However, as can be seen near the beginning of July, the timer occasionally malfunctions or is manually overridden. The 3D plot easily reveals when there is any deviation from the

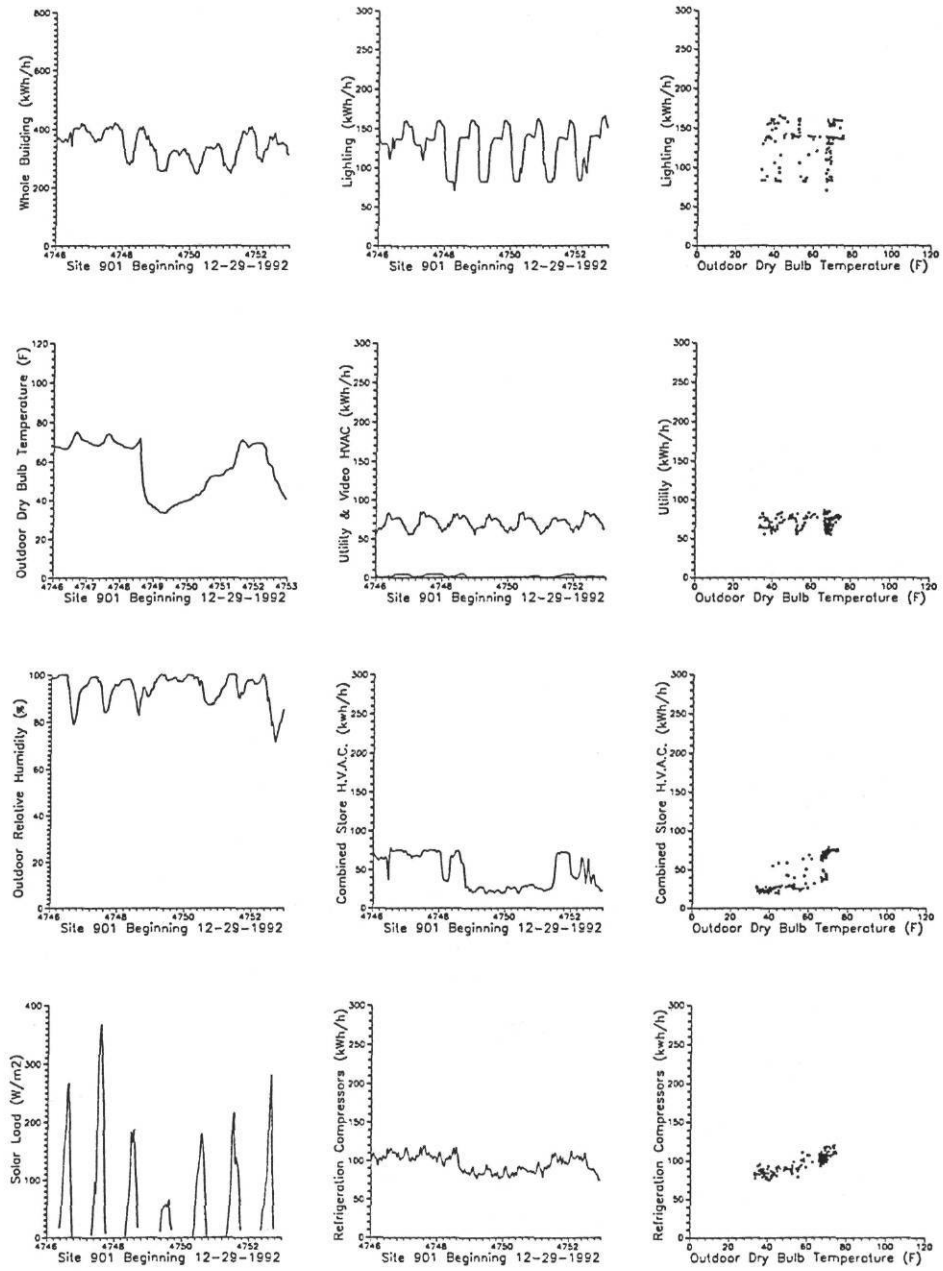
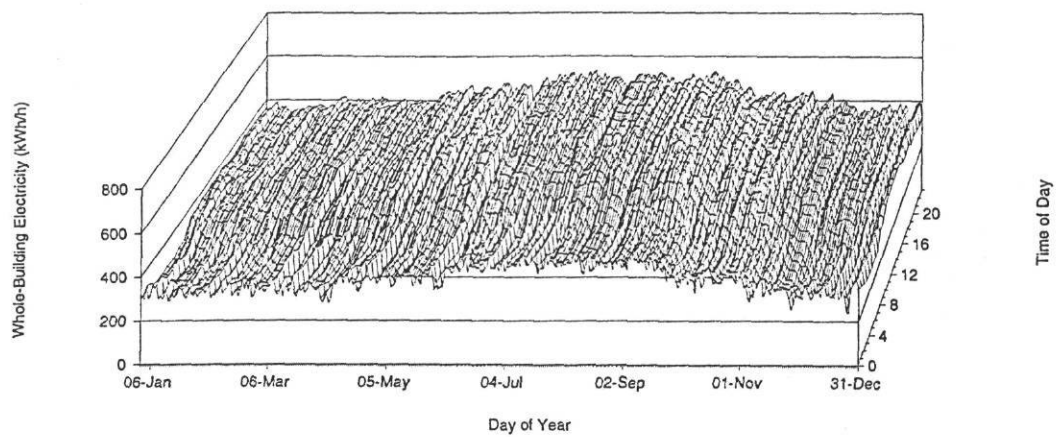
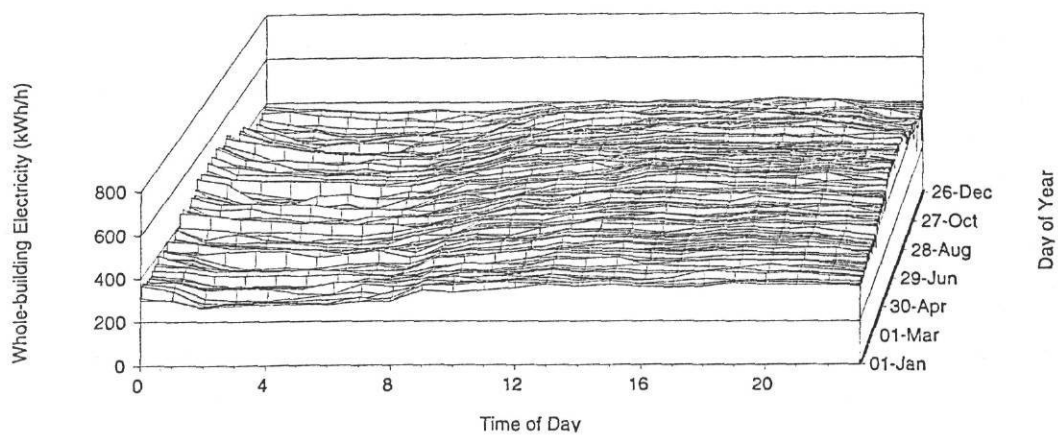


Figure 3.11 Summary inspection plots for College Station store.



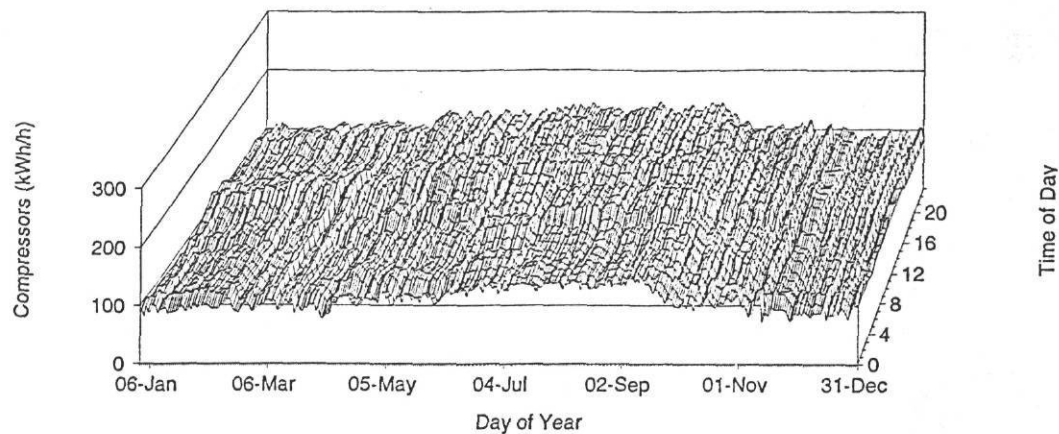
(a)



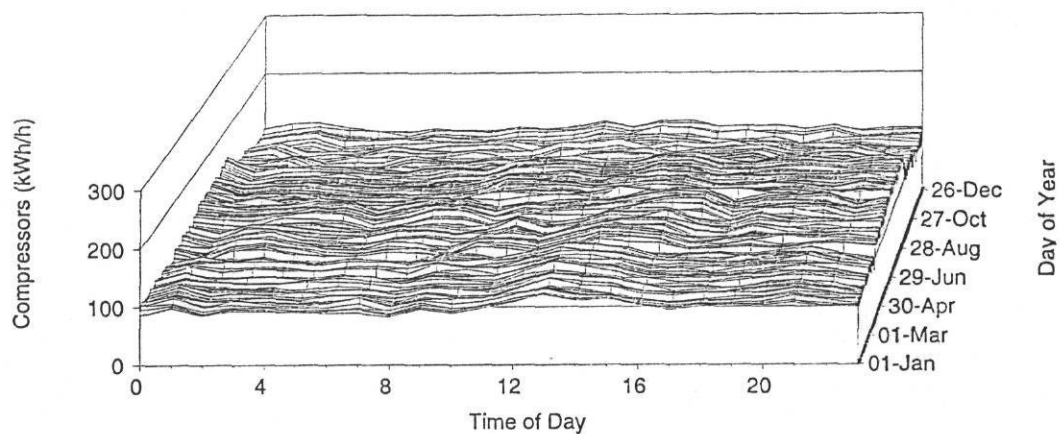
(b)

Figure 3.12 a,b 3D plot of whole-building electricity for College Station store..





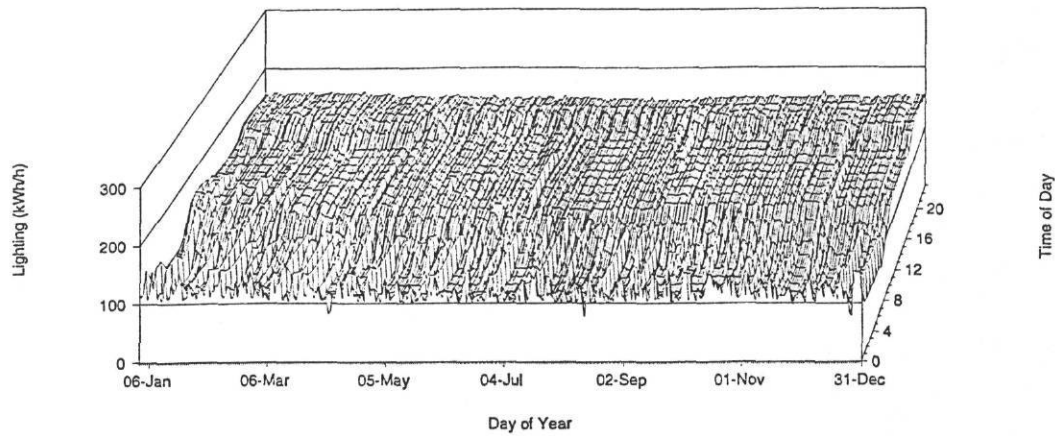
(a)



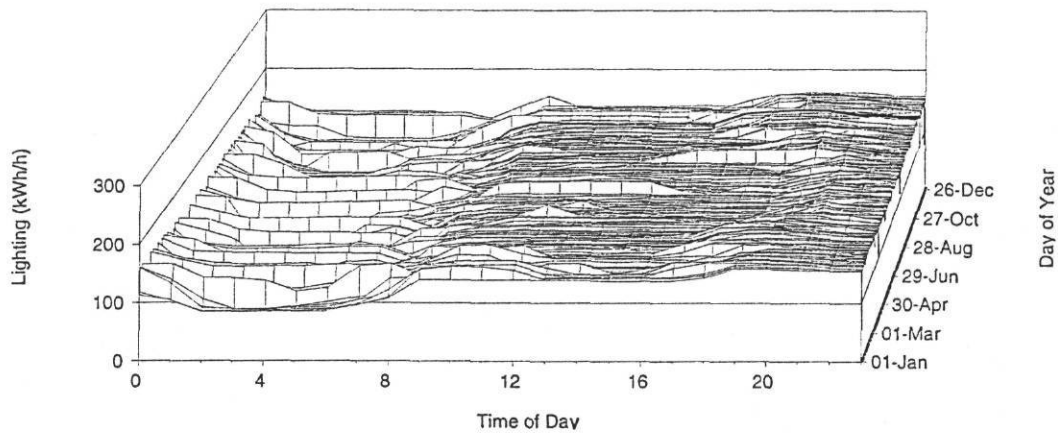
(b)

**Figure 3.13 a,b**

*3D plot of sub-metered refrigeration compressors for College Station store. A series of "rolling waves" appear in the data from hour to hour. Schrock and Claridge (1989) noticed this in the whole-building data, and hypothesized that it may be due to defrost timer controls being out of synchronization. They suggested that this might cause several defrost heaters to run at the same time, creating unnecessarily high levels of electric demand. The fact that the waves tend to occur at the same time each day lends support to this hypothesis.*



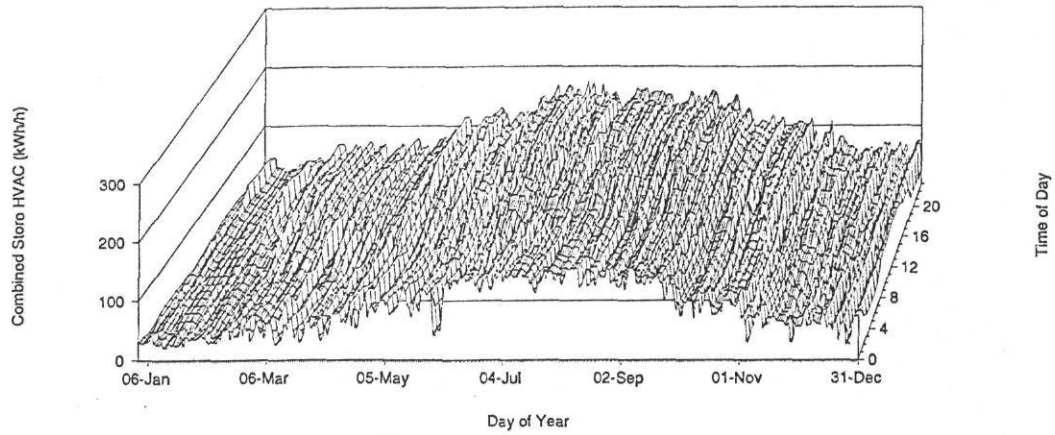
(a)



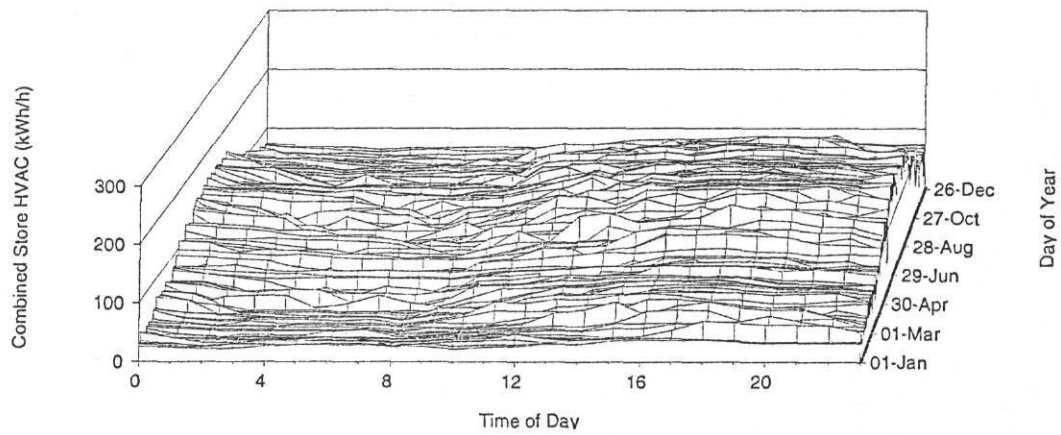
(b)

**Figure 3.14 a,b**

3D plot of sub-metered lighting for College Station store. The step in electricity use between 4 p.m. and 10 p.m. corresponds to the time at which the parking lot lights are turned on. The lights are controlled by a timer which is adjusted to account for the change in daylight hours, and shut off around 8 a.m. The times when the outdoor lights are left on after 8 a.m. are easily seen, most noticeably near the beginning of July. Between midnight and 7 a.m., half of the overhead, indoor sales lighting are scheduled to be turned off. At these times, the lighting load is about 100 kW. It is quite clear from the plots when the lights are left on.



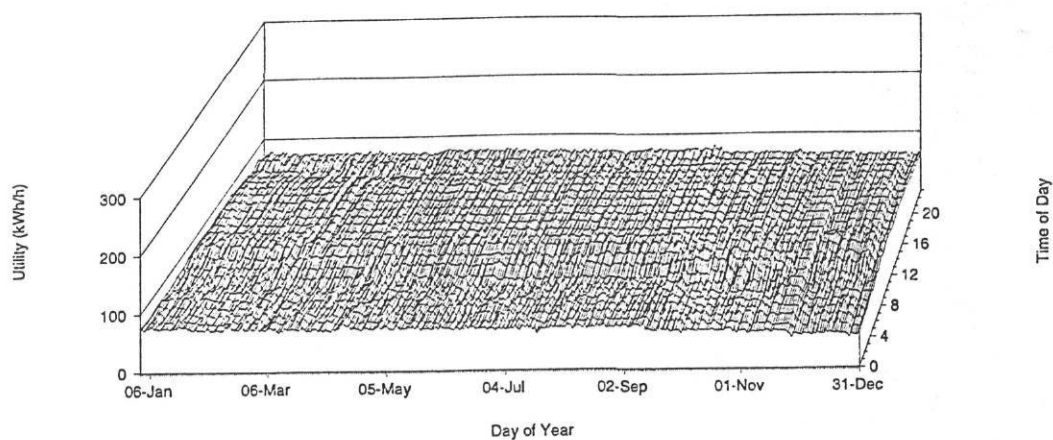
(a)



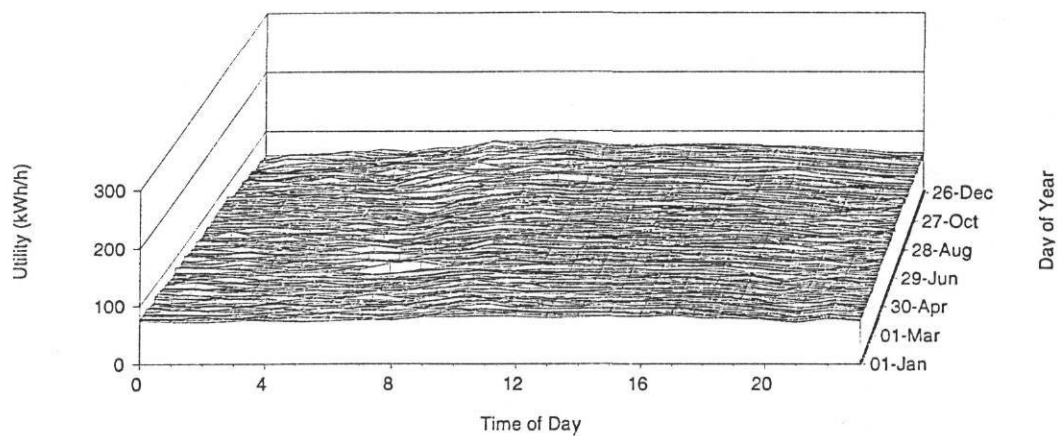
(b)

Figure 3.15 a,b

3D plot of sub-metered combined store HVAC for College Station store.



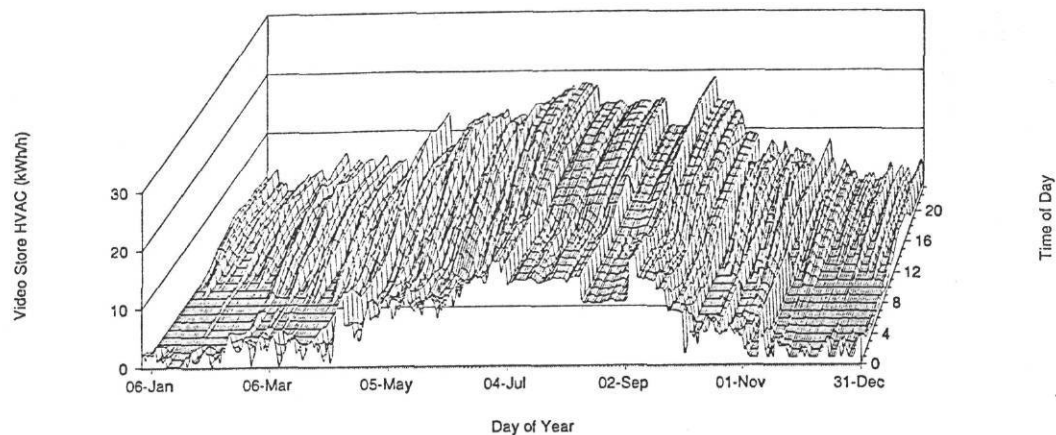
(a)



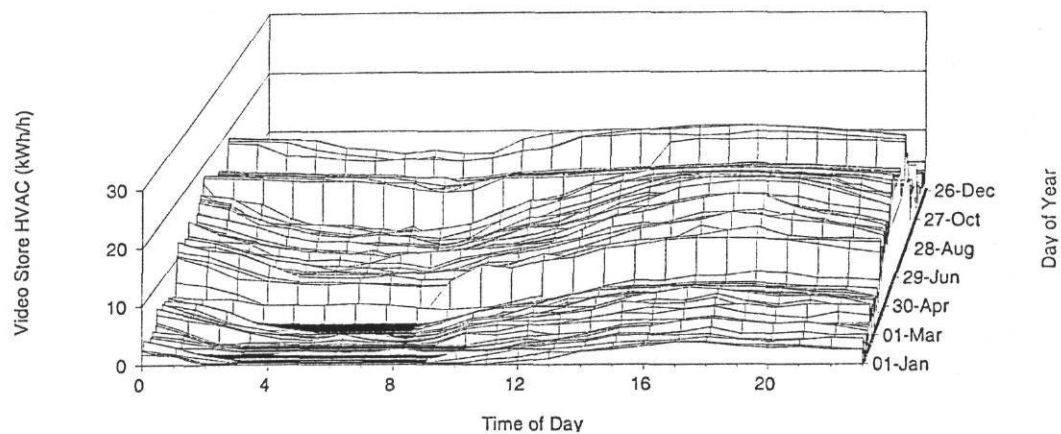
(b)

**Figure 3.16 a,b**

*3D plot of sub-metered utility for College Station store. The utility load includes food-preparation equipment, various receptacles, and refrigeration display case fans and anti-sweat heaters. The load is fairly constant throughout the year, but is slightly higher during the daytime than during the night. This makes sense since the food-preparation equipment is only run during the day.*



(a)



(b)

**Figure 3.17 a,b**

*3D plot of sub-metered video store HVAC for College Station store. This is the sub-metered load of two of the video store's 7.5-ton roof-top HVAC units. Most of the electricity use occurs during the summer months, when cooling is required. A period of maintenance problems can be seen between the middle of July and the beginning of September. Natural gas is used for heating in the winter. A 2- to 5-kW fan load can be seen between November and February. The heating provided by these two units is turned off when the video store closes at about 1 a.m., and comes back on when it opens around 8 a.m.*

usual lighting schedule when that schedule is very regular.<sup>14</sup> During the early morning hours, between midnight and 7 a.m., half of the overhead, indoor sales lighting are scheduled to be turned off except when required by stocking personnel. From Figure 3.14 (b), it is quite clear when the lights are left on. These occurrences are also visible in the whole-building plots (Figure 3.12), although less pronounced. When off, the lighting load is about 100 kW. When the indoor lights are kept on, there is an increase of roughly 50 kW. Visual inspection of the 3D lighting plot reveals that this occurs about twenty times per year, which is about once every two-and-a-half weeks.

Figure 3.16 shows the store's miscellaneous utility load. This includes such electrical end-uses as food-preparation equipment, and refrigeration display case fans and anti-sweat heaters. The load is fairly constant throughout the year, but is slightly higher during the daytime than during the night. This makes sense since the food-preparation equipment is only run during the day.

Figure 3.17 shows the sub-metered load of two of the video store's 7.5-ton roof-top HVAC units. Most of the electricity use occurs during the summer months, when cooling is required. A period of maintenance problems can be seen between the middle of July and the beginning of September.<sup>15</sup> Natural gas is used for heating in the winter. As can be seen in Figure 3.17 (a), only a 2- to 5-kW fan load can be seen between November and February. The heating provided by these two units is turned off when the video store closes at about 1 a.m. and comes back on when it opens around 8 a.m.

### 3.4.2 Constant and Schedule-dependent Loads

In anticipation of the statistical modeling detailed in Chapters 4 and 5, scatter plots of whole-building and component electricity loads were made. Figure 3.18 shows plots for daily electricity and weather data which were derived by averaging 24 hours of hourly data. From the plots, it is easy to see that some component loads are sensitive to outdoor temperature, while others are not. For some loads, the temperature dependency exhibits a strong change-point behavior. Some of these change-point loads have a bimodal characteristic. These are described below.

---

<sup>14</sup> As is the case during the afternoon hours.

<sup>15</sup> A fan belt had broken and the evaporator coils had frozen over. One compressor was taken out of service temporarily for repairs.

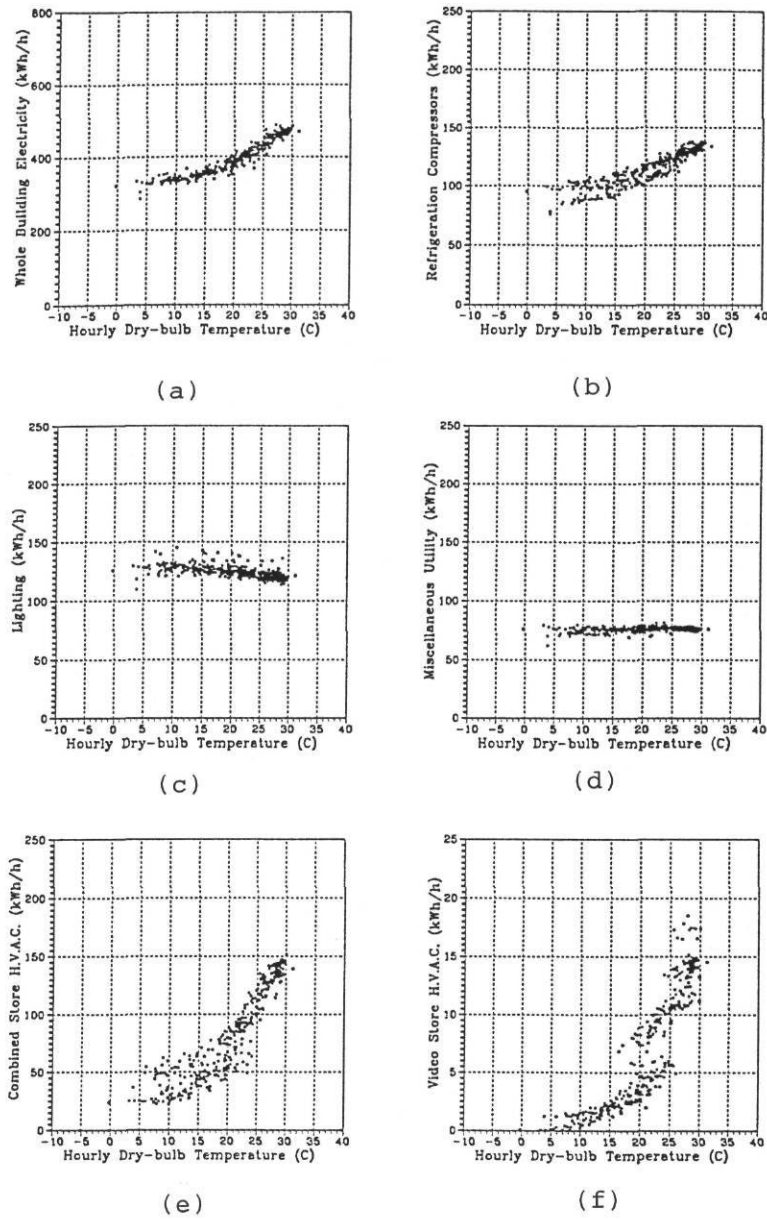


Figure 3.18 a-f Scatter Plots of Daily Loads vs. Outdoor Dry-bulb Temperature for the College Station store.

**Utility.** The daily average miscellaneous utility load, shown in Figure 3.18 (d), is quite constant. The hourly data in Figure 3.19 (d) appear to show a slightly lower energy use at lower temperatures. But this may not be a true effect of temperature, but rather an effect of hourly scheduling. Food preparation equipment is not run at night, when outdoor ambient temperatures are lower. This hypothesis is supported by the fact that when *daily* data are considered, which are not subject to the effects of hourly scheduling<sup>16</sup>, we see that there is practically no temperature dependency at all. The average value of the daily data is 76.4 kWh/h. When compared the maximum nameplate load connected to the Utility circuit, 148 kW this amounts to a combined diversity and load factor of 51%. This represents a significant difference; had we relied only on a nameplate survey to estimate store energy use, the Utility load would have been twice what it actually is.

**Lighting.** As discussed in Section 3.2.3, the lighting load is dependent on hourly schedules. It is also dependent on changes in the length of the day. The daily lighting load shows a decrease at higher temperatures (see Figure 3.18 (c)). This diurnal pattern of energy use is expected since the hot summer days have shorter nights, resulting in the parking lot lights being on less.<sup>17</sup> This diurnal effect can only be seen in the daily data. A band of about 15 outliers (about 15 to 20 kW higher than the rest of the data) can be seen in the lighting-temperature plot above most of the other points. During 1991, there were about 45 such outliers. These represent days during which either the parking lot lights or some interior lights (or both) were left on when they should have been off.

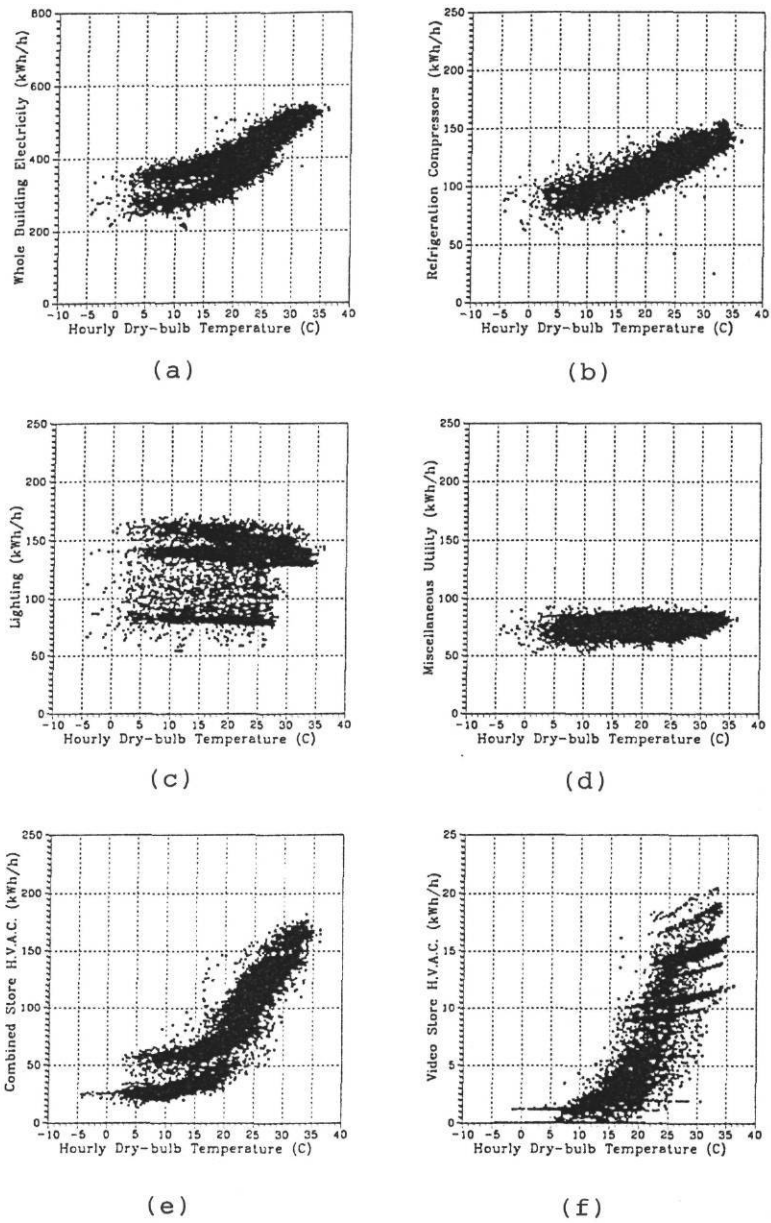
Comparing the daily and hourly plots, it is apparent that use of hourly data adds scatter, and shows the extremes of the energy use. While for the purposes of regression modeling, the general characteristics of the hourly loads can be predicted by daily data, the hourly data reveal important facts about the lighting load which the daily data cannot. In Figure 3.19 (c), three modes of usage may be seen in the hourly lighting data -- one during the early morning when many of the interior lights are off and the parking lot lights are on; one during the day, when only interior lights are on; and one during the night, when the parking lot lights and all interior lights are on. This

---

<sup>16</sup> This is true provided that the hourly scheduling is the same from day to day.

<sup>17</sup> Parking lot lights represent about 20 kW, almost 12% of the peak connected lighting load. They are controlled by a timer which is adjusted monthly for the changing periods of daylight throughout the year. Their operation can be seen in Figure 3.14 as well as Figure 3.19.





*Figure 3.19 a-f* Scatter plots of Hourly Loads vs. Outdoor Dry-bulb Temperature for the College Station store.

reveals the daily lighting schedule which was shown earlier in Figure 3.5. The daily average data are closer to the upper two modes of energy use, indicating that there are more hours of the day when most the lights are on. This is not surprising since the middle and upper mode occur from 8 a.m. to 12 p.m. -- 16 hours of the day.

The length-of-day characteristic of the lighting load cannot be seen by viewing only the daily lighting data. When operational problems occur, such as lights remaining on when they should not be, these may only show up in daily data as an electricity consumption which is slightly greater than usual. Only in hourly data is such a problem easily noticed.

### 3.4.3 Temperature-dependent Loads

As mentioned above, some electricity load components are dependent on temperature rather than daily scheduling. For the College Station store, these loads are the HVAC and refrigeration systems. The whole-building data, shown in Figure 3.18 (a) have a strong temperature change-point characteristic. There is a noticeable bend in the curve at about 64°F (18°C). This is a result of the behavior of the temperature-dependent component loads.

**Refrigeration.** From Figure 3.18 (b), refrigeration compressor loads seem to be linearly related to outdoor air temperature. Below temperatures of 60°F to 65°F, two modes of electricity use are seen. It is clear that there is a change-point operation. This is discussed in the sub-section on bimodality which follows. The slope in the refrigeration curve is due to the fact that when the outdoor air is warmer, the condensers run hotter which requires the refrigeration compressors to run longer to realize the desired cooling effect. Essentially, this makes the refrigeration cycle less efficient. Both daily and hourly data reflect this trend. But as seen in Figure 3.19 (b), hourly data have so much scatter that the temperature change-point seen in the daily data is obscured.

**HVAC.** The main store HVAC load is due to two air-handling systems and three of the smaller video store HVAC units. Both systems in the main store have a set-point of 75°F (24°C) and 55% RH. The video store systems are set at 75°F. Below the set-point, in the main store air-handlers, only the fans run. Above the set-point, fans and compressors run.<sup>18</sup> In Figure 3.18 (e), the outdoor air change-point

---

<sup>18</sup> The two fans comprise 13.6 kW each. The four compressors draw between 17.1 and 29.3 kW each (measured on different occasions).

temperature for the combined HVAC load can be visually estimated at about 65°F (18.7°C). The HVAC load appears to have a linear relationship with temperature above the change-point. The data below the change-point are thought to involve mostly fan loads and dehumidification (one compressor) loads. Two modes of data are clearly present below the change-point in both the hourly and daily data. The lower, about 20 kW, is the fan load; the upper, at about 50 kW, is the fan load plus one compressor which is being used during the heating season (when temperatures are below about 75°F (24°C)) for dehumidification. This is a reheating process. This bimodality shows up in the refrigeration compressor data as well.

**Bimodality.** The HVAC system is equipped with heat reclaim coils through which hot refrigerant from the refrigeration compressors flows when space heating is needed. These coils function as the refrigeration system condensers, and yield their heat to the HVAC air stream. When reheat or dehumidification is occurring, chilled air is blown across the heat-reclamation coils in the air duct. Since the air being blown across them is often cooler than the outdoor ambient air, which otherwise is used to cool the condensers, the refrigeration system operates more efficiently. The bimodality in HVAC operation has the effect of producing a bimodality in the refrigeration system energy use. These two modes may be seen in the refrigeration data below about 65°F (18.7°C) (see Figure 3.18 (b)).

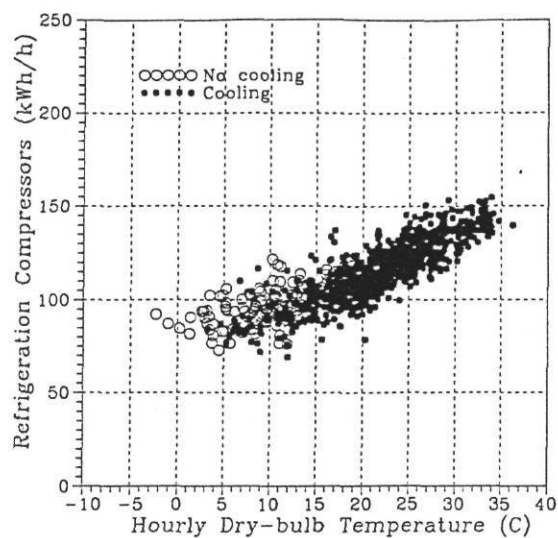
Below 65°F, there is less dependency on outdoor ambient temperature. This is because when dehumidification is occurring, the condensers are by-passed so that heat reclaim is possible, and the refrigeration system yields its waste heat to the HVAC air stream. The temperature of this air stream does not change when outdoor air temperature changes.

While the use of reheat with heat reclamation may help to explain the 65°F (18.7°C) change-point, there is another factor involved. In the compressor room, when heat reclamation is not in use, the condenser coils are exposed to ambient air which is drawn into the room and exhausted through the roof by four large fans. As described in Section 3.2.1, these fans control the room air temperature, but do not let it drop below 60°F (16°C). As outdoor temperature drops, the refrigeration system energy consumption also decreases. However, during periods when outdoor temperatures fall below about 60°F, compressor room temperature remains at or above 60°F, thus eliminating the further effects of falling outdoor ambient temperature on the refrigeration system energy use.

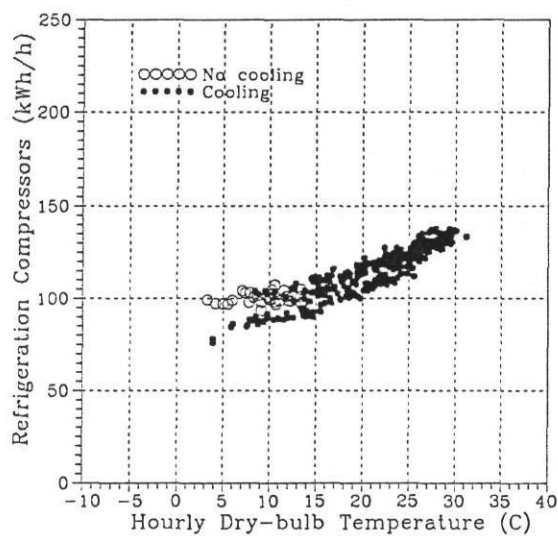
When heat reclaim is used, and when one stage of cooling is necessary for dehumidification purposes, energy is saved in two ways. First, the refrigeration system provides the necessary space heating. Second, the heat reclaim coils serve as the refrigeration system condenser coils; since these coils are exposed to air which is cooler than the minimum compressor room temperature (60°F [16°C]), the refrigeration system operates more efficiently. In Figure 3.20b, we see that in both modes of refrigeration system energy use, below about 60°F, the curve is fairly flat. This is to be expected since, whether the heat reclaim coils are being used or the compressor room condenser coils are used to reject heat, the temperature at which the system rejects its heat is fairly constant.

Since the fan load of the main HVAC units is between 25 and 30 kW, we were able to determine from the sub-metered HVAC load when there was no cooling coil load by looking for an HVAC energy consumption less than 30 kW. Thus, the sub-metered refrigeration compressor load data were sorted into times when the heat reclaim coils were or were not exposed to chilled, conditioned air. Figure 3.20a shows the hourly refrigerator compressor data sorted according to when the HVAC cooling system is on (designated by a filled symbol) and when it is not (unfilled symbol). In the hourly data, it is difficult to determine if there is any difference in the refrigeration load as a result of the HVAC cooling system. There is too much scatter in the data.

However, when daily averaged data are used, the difference in the two modes is quite clear. The daily data in Figure 3.20b clearly show the two modes in the refrigeration energy use which correspond to the two modes of HVAC system operation below the change-point temperature, that is: 1) when one or more stages of cooling are running (filled symbol), and 2) when only the air-handler fans are running (unfilled symbol). This difference is only apparent when the outdoor temperature is below the 65°F (18.7°C) change-point. This is to be expected since waste heat from the refrigeration system is no longer used when the building is in the cooling-only mode of operation.



(a)



(b)

**Figure 3.20 a,b**

*Bimodality of refrigeration load. a) Scatter in hourly data make the two modes of energy use below 65°F (16°C) difficult to see. b) Daily data reveal the two modes of energy use. Sorting these data shows that the lower mode corresponds to times when the HVAC cooling stage is running. The higher refrigeration mode corresponds to times when only the fans of the HVAC system are in use.*

The video store HVAC system is comprised of five small roof-top units, the two largest of which are monitored on the video store HVAC load. These systems have a history of maintenance problems. The 3D plot of those data showed a relatively high base load profile for the summer of 1991. This was the result of control malfunctions which persisted for several months.

In Figure 3.18 (f), daily data for the video store HVAC system seem to fall into two clusters separated by a step change -- one cluster from 40 to 70°F (5 to 21°C), and the other from 70 to 85°F (21 to 30°C). This is thought to be an effect of the maintenance problems and staged operation of the air-conditioner compressors.

In the hourly video store HVAC data, shown in Figure 3.19 (f), a pattern of eight modes, or "rays", can be seen. Each of the two air-conditioner units has two compressors. Due to the staged operation of these compressors (each compressor may either be on or off), there should be  $2 \times 2 \times 2$ , or 8, modes of operation. This agrees with the eight modes seen in the Figure 3.19 (f). The first mode is an almost flat profile, as expected. This represents the fan-only operation of the two HVAC units<sup>19</sup>. The second distinct mode appears at about 7 kW. This is the load of the first compressor on one unit plus the fans on both units. We leave the reader to identify the remaining modes. The scatter in between modes is due to the operation of the other components of each HVAC unit -- condenser fans, gas furnace blowers, and controls.

A zero base load appears in the video store HVAC profile for outdoor temperatures less than about 65°F (19°C). This indicates that the two HVAC systems on that channel are being completely shut off during periods when temperature falls below 65°F (19°C). This can be seen in Figure 3.19 (f) as well. This should not be too surprising since the video store has three other HVAC units (sub-metered along with the main store HVAC) which may be operating when the first two are off. The other three units are monitored along with the main store HVAC load. The base load of the main store HVAC system is about 25 kW. There are times when only this load occurs in the combined-store HVAC data. This occurs for outdoor temperatures between -5° and 0°C (22° and 32°F). Thus, there are times when all of the video store HVAC units must be either off or running in fan-only mode.

---

<sup>19</sup> The fans referred to here are the evaporator fans.

### **3.5 BUILDING STRUCTURE OF BRYAN STORE**

Like the first case study store, the second store is located in a medium-sized business plaza. Customer parking is available at the front of the store, while deliveries are made at the rear. One-third of the southeast wall is shared with an adjacent, air-conditioned office building, not associated with the store.

The construction of the second store is similar to that of the first. The exterior walls are constructed of 6-inch (0.15-m), poured concrete, and have 3.5 inches (0.09 m) of batt insulation behind interior dry-wall. The northeast and southwest walls are about 160 feet (49 m) and 330 feet (101 m) long, respectively, and 24 feet (7.3 m) high. The northeast wall has a 60-ft by 10-ft (18-m by 3-m) glass section which serves as the entrance to the store and includes a double-doored enclosure with automatic, sliding doors. The roof is constructed of a metal deck which supports a 1.5-inch (0.04-m) layer of styrofoam insulation, a 2-inch (0.05) concrete slab, and a built-up roof covered with light-colored aggregate. A plan view of the store is shown in Figure 3.21.

The building is a single-story structure with 16-foot (4.9-m) drop ceilings and a total area of 48,800 ft<sup>2</sup> (4,540 m<sup>2</sup>). The front floor area is used for product display, and the rear walk-in coolers and freezers, and the meat and produce preparation areas. The store contains about 500-ft<sup>2</sup> (46-m<sup>2</sup>) office space located above the produce area, and a 150-ft<sup>2</sup> (14-m<sup>2</sup>) mechanical room located above the loading dock in the rear of the store.

### **3.6 MAJOR ELECTRICAL EQUIPMENT OF BRYAN STORE**

This section describes the major energy-using equipment in the Bryan store. The information was gathered in walk-through surveys consisting of nameplate readings and actual clamp-on power readings (where possible). Lighting and miscellaneous utility equipment in the Bryan store runs at 120 VAC and 208 VAC, while air-conditioning and refrigeration compressors run at 480 VAC. A detailed listing of the loads can be found in Appendix B of this thesis. The electrical end-use distribution at the Bryan store is not as well organized as it is at the College Station store. There are lighting loads on the miscellaneous utility circuit, and utility loads and a few HVAC loads on the lighting circuit. Because of this, the four main end-use categories listed below -- refrigeration, HVAC, lighting, and utility -- do not necessarily coincide with the load categories measured through the electrical sub-metering.



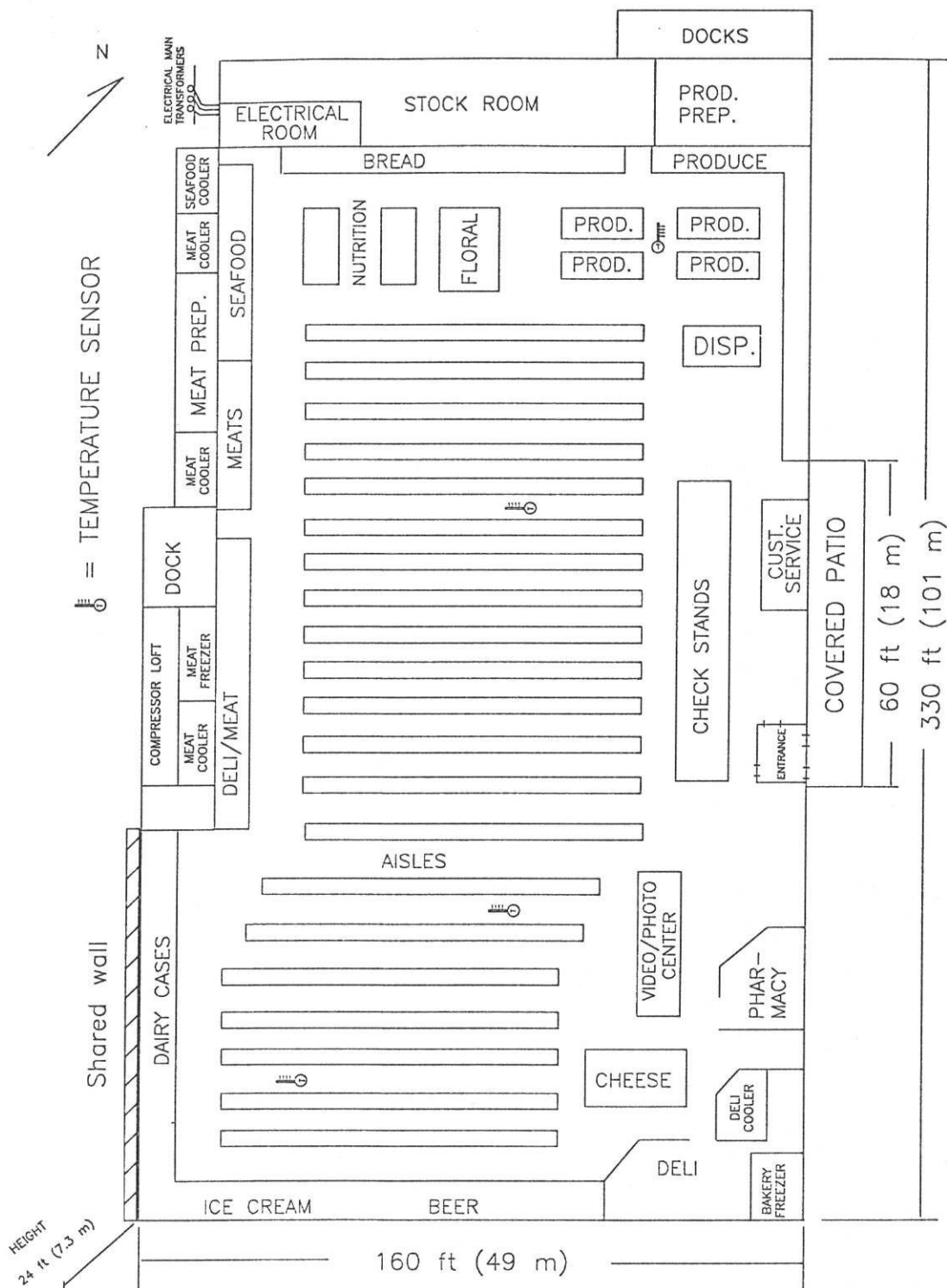


Figure 3.21

Plan view of the Bryan grocery store.



### 3.6.1 Refrigeration Equipment.

Twenty-three single-mounted compressors are used to cool the refrigeration/freezer cases and coolers in the facility. Thirteen use refrigerant R12, and ten use refrigerant R502. The total compressor nameplate capacity is 196 hp, or 162 kW input. Condenser fans comprise 7.3 kW (nameplate). The electric resistance defrost heaters have a total nameplate load of 40 kW.

Including condenser fans, the measured, connected compressor system load is 142 kW. Some display cases use hot gas defrost provided by the compressors to melt the ice which forms on the evaporator coils. Others use the electric resistance heaters for this purpose. A high load of 167 kW was measured during defrost cycles, implying an electric defrost load of 25 kW. Time clocks control the compressor defrost cycles. The defrost cycles last up to 1 hour or until the cooling coils reach 70°F (21°C). The compressors are summarized as follows in Table 3.3.

Outdoor ambient air is circulated through the compressor room by five 6-hp fans which have a total nameplate load of 28 kW. These fans come on in stages beginning when the temperature difference across the condenser coils is about 8°F (4°C), and ending when the compressor room ambient temperature is less than about 60°F (16°C).

The total connected load of the compressor system and exhaust fans, based on measured loads, is 170 kW under normal operation, and 195 kW during coincident defrost periods. The peak load based on nameplate information is 197 kW during non-defrost periods, and 237 kW during coincident defrost periods.

Approximately seventy-six display case sections display the frozen goods. There are seven walk-in coolers which are used to store meat and other frozen foods. These loads -- case lighting, fans, and anti-sweat heaters -- are connected to what was designated as the lighting circuit of the store.<sup>20</sup> The peak connected nameplate load of the refrigeration case fans and anti-sweat heaters is 36 kW during non-defrost periods. Including defrost heaters, the peak load is 76 kW. See the section on lighting below for more information.

---

<sup>20</sup> This is different than the case loads for the College Station store.

TABLE 3.3  
Refrigeration Compressor Summary for Bryan Store

Description	Refrigerant	Rated HP	Measured kW	Measured kW with defrost*
Cheese Cases COOLER	R12	5	3.96	3.96
Dairy Cases	R12	10	8.47	8.47
36' Dairy Cases	R12	7.6	7.39	7.39
28' 5-DK Lunch Meat	R12	15	7.66	7.66
20' Lunch Meat COOLER	R12	7.65	5.49	5.49
Walk-in Groc FRZR	R502	7.6	5.40	6.48
Glass DR N.E. Reach-in FRZR	R502	7.65	5.94	5.94
4 Glass Door at Rear	R502	15	7.93	11.98
Ice Cream & Bakery FRZRS	R502	15	7.57	11.71
Glass DR N.W. Reach-in FRZR	R502	7.65	6.30	11.17
Prod., Beer, Dairy Reach-in	R12	10	8.29	8.29
Meat Cooler/Holding Box	R12	7.6	6.30	4.95
Produce Case COOLER	R12	15	9.01	9.01
Walk-in Produce & Meat Prep	R12	10	8.92	8.92
44' 3-DK Red Meat Cases	R12	15	9.28	9.28
32' 13-DR D5F	R22	6	4.59	6.30
Food End Cap FRZR	R502	5	3.60	7.30
Walk-in Deli FRZR	R502	3.1	3.60	4.05
"Deli Cases Cooler Retarder"	R502	3.1	2.88	2.88
12' Sausage Deli Case COOLER	R502	5	3.78	3.78
40' Frozen Meat/Spot Cases	R502	7.6	6.12	12.25
Coffin Meat and Floral Cases	R12	3.1	3.33	3.33
Produce Islands	R12	7.65	6.48	6.48
<b>Total:</b>		<b>196</b>	<b>142.31</b>	<b>167.07</b>

\* Hot gas defrost. Some display cases use electric heaters for defrost. Electric heater loads are part of the Miscellaneous Utility loads (see below).

### 3.6.2 HVAC Equipment

Twelve roof-top HVAC units having a total cooling capacity of 114 tons heat and cool the facility. The units are controlled in groups by four zone controls which demand heating or cooling based on four indoor dry-bulb temperature sensors. The store set point is 75°F (24°C) dry-bulb. There is no humidity control in the Bryan store. The total peak cooling load of the air-conditioning units totals 183 kW (nameplate), giving an overall EER of 7.47 Btu/hr·W.<sup>21</sup> During the six months since monitoring began, normal running load of the HVAC system has not exceeded about 90 kW. The systems are detailed in Table 3.4

Space heating is provided by means of natural gas-fired heaters installed in seven of the HVAC units. These heaters have a total capacity of 1,215,000 Btu/hr (356 kW<sub>th</sub>). Unlike the College Station store, these units do not utilize heat reclamation from the refrigeration compressors. For the years of 1990 to 1992, the Bryan store used an average of 691 million Btu/yr of natural gas for heating. This is 14,200 Btu/ft<sup>2</sup>·yr -- about 4,200 Btu/ft<sup>2</sup>·yr less than the College Station store.

### 3.6.3 Lighting

The main store's interior is primarily lit by fluorescent lamps ranging from 40 to 100 W/lamp. Of these, there are approximately 1544 overhead lamps in the sales area (with a total nameplate load of 91 kW), 289 overhead lamps for non-sales areas (18 kW), and 414 refrigerated case and rack lamps (24 kW).

About one-half of the sales and back room overhead lights, all bakery lights, and lights on perimeter refrigeration cases are shut off at 10:00 a.m. by the store manager. They are turned back on around 8:00 a.m. This is currently done by

---

<sup>21</sup> The total rated capacity of the units is 114 tons. At 12,000 Btu/h-ton, the bulk rated capacity of the HVAC units is 1.37(10<sup>6</sup>) Btu/h. Dividing this by the peak rated electrical load of 183 kW gives an EER of 7.47 Btu/hr·W.

TABLE 3.4  
HVAC System Summary for Bryan Store

Unit	Cooling Tons	Rated kW	Measured kW	EER	Heating Capacity (Btu/h)
Conference room**	7.2	10.13	7.80	8.53	none
Produce zone	14	20.74	20.49	8.10	none
Nutrition	10	15.73	4.39	7.63	123,000
Grocery	10	16.63	off	7.22	none
Grocery	8	16.31	8.05	5.89	181,000*
Manager's office**	7.2	10.49	8.54	8.23	none
Grocery	10	16.83	off	7.13	131,000
Grocery	10	16.31	14.63	7.36	173,000
Dry goods	10	11.57	off	10.4	181,000
Dry goods	7.5	16.31	off	5.52	164,000
Beverages/beer	10	16.08	14.63	7.46	131,000
Beverages/beer	10	16.08	off	7.46	131,000
<b>Total:</b>	<b>114</b>	<b>183.22</b>	<b>78.53</b>		<b>1,215,000</b>

\* converted to equivalent Btu/h

\*\* These units are connected to the store's Utility circuit

switching the power off at the electrical panel in the rear of the store. This pattern of electricity use can be seen in Figure 3.22 which shows a day's worth of hourly data from the sub-metered circuit which is primarily lighting.<sup>22</sup>

The main store also has 10 metal halide lamps (175-W). These amount to a connected load of 2.1 kW including ballast loads.

The exterior lights, used to illuminate the front and rear parking lots, consist of 14 1,000-W and six 400-W high-pressure sodium lamps which have a total connected load of 20.5 kW (nameplate). All outside lamps are controlled by a time-clock inside the store. They are set to switch on at about 6 p.m., and switch off at 8 a.m. (see Figure 3.23) The timer pins are adjusted twice a year to account for daylight savings time. These lights are not on the designated lighting circuit, but are connected to the utility circuit.

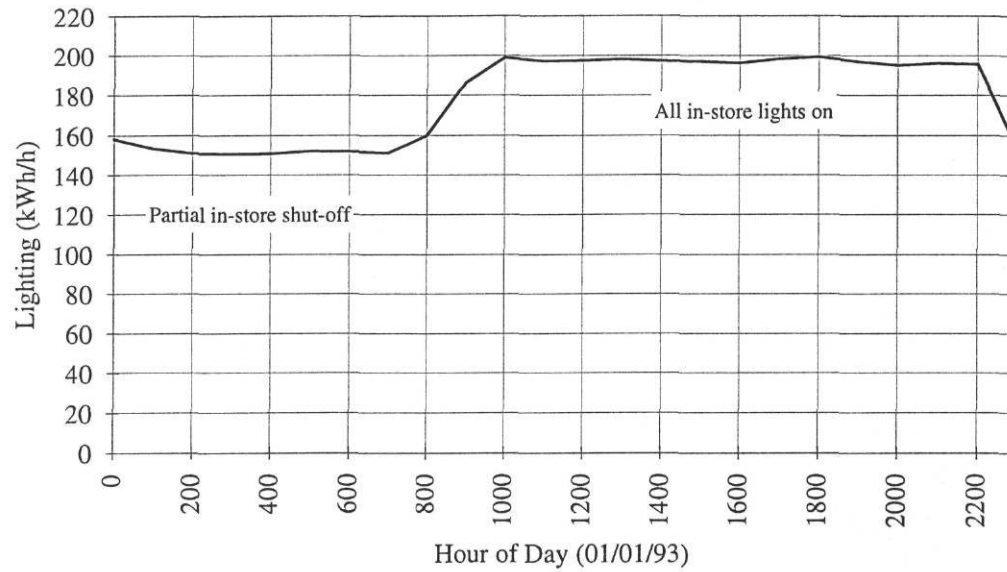
The peak connected load of all the lights in the store is 159 kW (nameplate), though the average daily load adjusted for schedules is 113 kW. This amounts to a 71% diversity factor.

There are approximately 76 refrigerated display case units. The evaporator fans and anti-sweat heaters of these cases contribute about 34 kW to the lighting circuit load. Some cases use electric heaters for defrost cycles. As mentioned earlier, these heaters have a total nameplate load of 40 kW. Seven walk-in coolers and freezers are located in the store's back rooms, which have a total evaporator fan load of 2.1 kW during normal operation. Thus, the peak connected nameplate load of the refrigeration case fans and anti-sweat heaters is 36 kW. This represents 18% of the total nameplate load on the lighting circuit.

The total load on the lighting circuit, including lights and display case loads, is 195 kW.

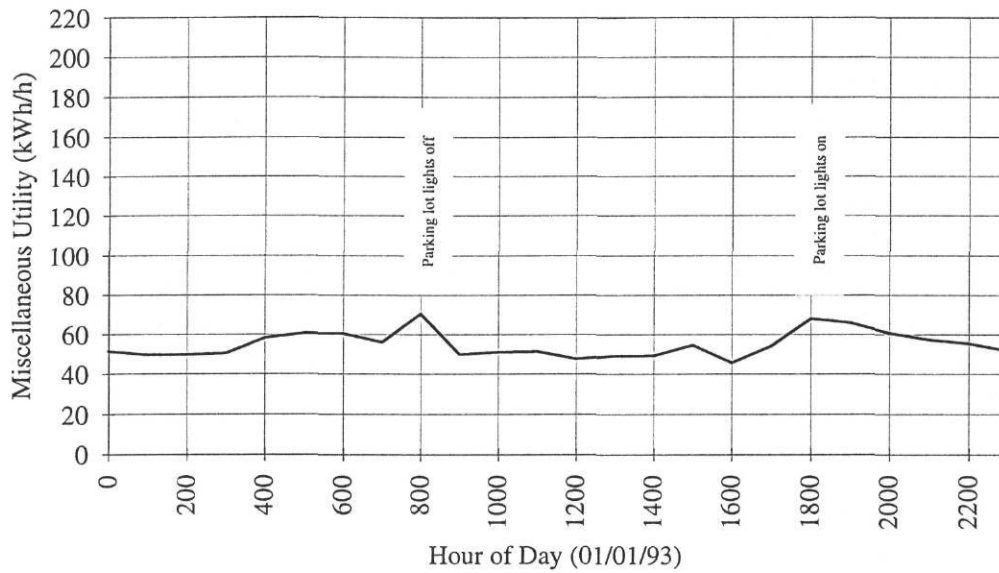
---

<sup>22</sup> There are some meat department equipment loads on this circuit as well.



**Figure 3.22**

*Lighting schedule profile for a typical day (01/01/93) at the Bryan store. While this indoor lighting circuit contains refrigeration case fan and anti-sweat heater loads, the effect of the indoor store lighting system schedule is clear. About half of the overhead sales area lights, and all perimeter case lights are turned off at 10:00 p.m., and turned on at 8:00 a.m.*



**Figure 3.23**

*Utility load profile for a typical day (01/01/93) at the Bryan store. The parking lot lights, which represent about 20 kW, are connected to the utility circuit. Their switch-on and switch-off can be seen at 6 p.m. and 8 a.m., respectively.*

### 3.6.4 Miscellaneous Utility

The remaining electrical loads mentioned in this section are listed in detail in Appendix B.

There are 32 pieces of food-processing equipment used for the preparation of meat and deli goods. These items have a total connected load of 114 kW (nameplate) and are used when needed.

One 5-hp trash baler is located in the loading dock room. At an efficiency of 0.85, its connected load is 4.6 kW.

The store has 13 point-of-sale registers throughout the store which have a total connected load of 6.8 kW (nameplate). These are connected to its Utility circuit.

The total, peak utility load is 125 kW, though this never occurs since all utility loads rarely run at the same time.

There are two roof-top HVAC units which are connected to the store's miscellaneous utility circuit. These units have a combined, measured load of 16 kW, and a peak nameplate load of 21 kW. As mentioned above, the parking lot lights, representing a nameplate load of 21 kW, are connected to the utility circuit.

### 3.6.5 Natural Gas

The store uses natural gas for heating purposes only. The HVAC gas use is described in Section 3.8.

## 3.7 ELECTRICAL SUB-METERING OF BRYAN STORE

The Bryan store has only recently come under study (since the Fall of 1992). An attempt was made to obtain the same information about the second store as about the first. The monitoring scheme for the Bryan store is similar to that in the College Station store, although the sub-metered electrical circuits do not divide the store's electricity end-uses as distinctly as the sub-metering at the College Station store. Four component end-use loads of interest for the store were sub-metered. These were:

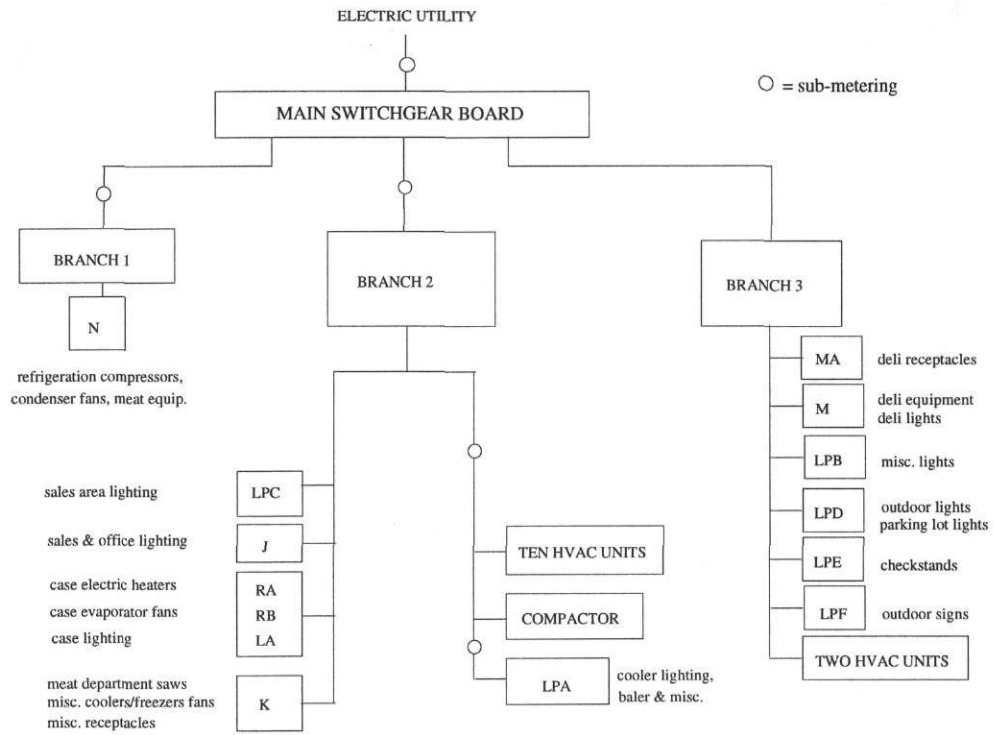
- 1) refrigeration compressor, condenser, and defrost heater loads.
- 2) interior and refrigeration case lighting, fan, and anti-sweat heater loads; some meat preparation equipment.



- 3) ten of twelve roof-top HVAC unit loads.
- 4) miscellaneous utility loads, food preparation, exterior lights, two of twelve HVAC unit loads.

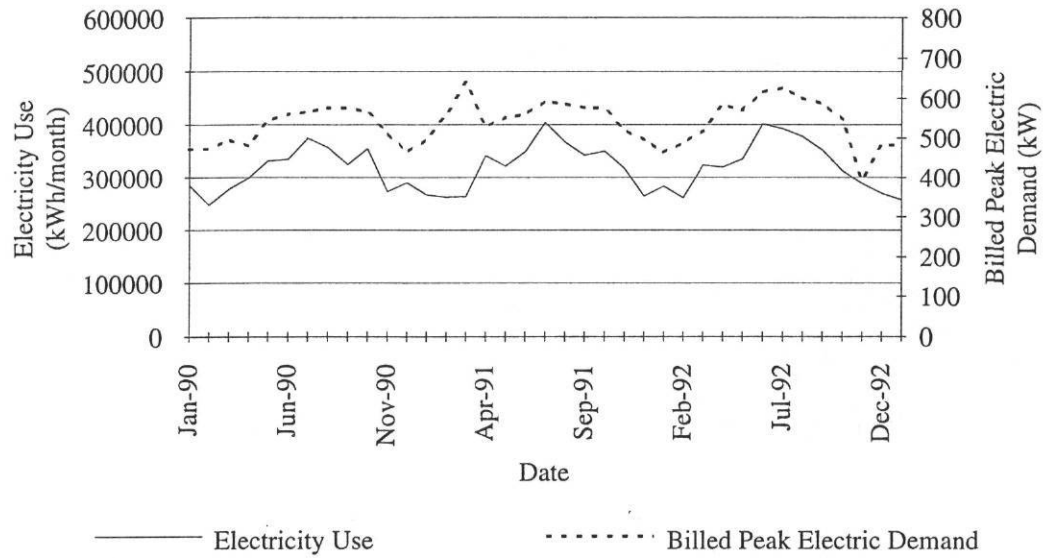
Loads were monitored and data were polled in the same manner as for the first case study store. Figure 3.24 shows the layout for the store monitoring. Because the electrical layout does not group all lighting and utility loads separately, there was no way to completely distinguish lighting loads from utility loads with the level of sub-metering used. However, experience with the College Station store suggests that this is not a problem since, for analysis purposes, the lighting and utility loads are treated as one combined, constant load. Thus, the level of sub-metering at the Bryan store was considered adequate for this study. Since the store has only been monitored for less than a full year, much of the analyses performed on the first store cannot yet be done on the second. This store will be useful material for future study, although it will be considered in Chapter 5.

Figure 3.25 is a plot of the Bryan store's electricity use and demand from January 1990 to January 1993. Unlike the College Station store, its electricity consumption has remained fairly constant over the past three years. There have been no major modifications to this store's electrical system in that period. The Bryan store used an average of 3,884,000 kWh/yr in the two years (1991-1992) since the multi-store energy use survey (in Chapter 2). This amounts to an electricity energy use intensity (EUI) of 9.1 W/ft<sup>2</sup> (98 W/m<sup>2</sup>). These values do not differ significantly from those reported in the multi-store survey. Figure 3.26 shows monthly natural gas consumption from January 1990 to January 1993. The Bryan store used an average of 734 million Btu/yr of natural gas during 1991 and 1992. This is about 120 million Btu more than the College Station store. This amounts to a gas EUI of 15,000 Btu/ft<sup>2</sup>·yr -- only 400 Btu/ft<sup>2</sup>·yr less than the College Station store. However, the Bryan store's *peak* gas use is significantly higher than that of the College Station store. High peak consumption can be seen in January of each year. This is clearly a result of space heating requirements during the very cold months. This occurs because the Bryan store does not use reclaim heat from the refrigeration system. Significant space heating is only used during one or two months per year for the past three years (1990 to 1992). The store's base-level consumption is about 35 million Btu/month. This is attributed to the heater pilot lights. Based on utility bill information, the average

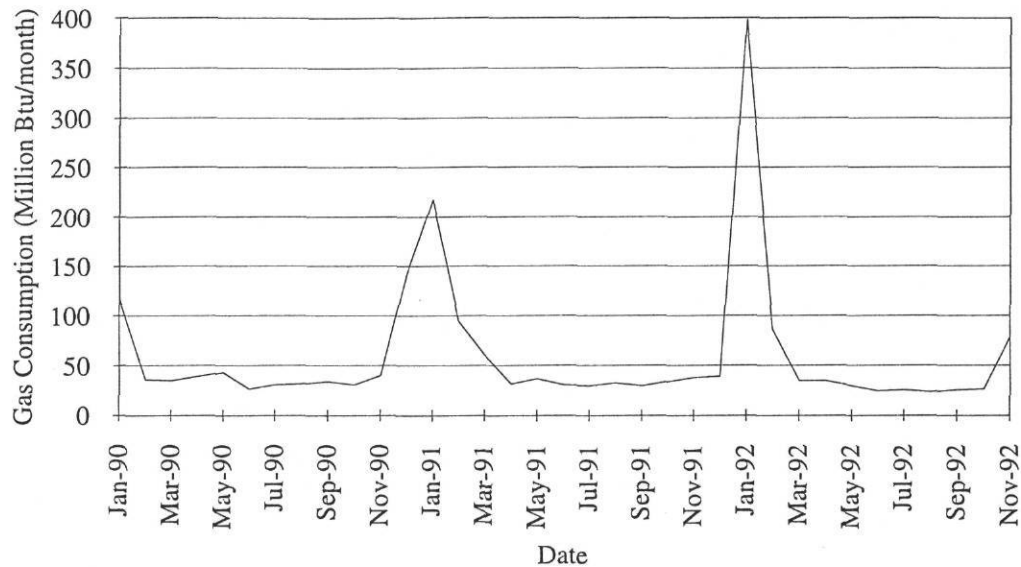


**Figure 3.24**

*Sub-metered Electrical Circuit in the Bryan Store*



**Figure 3.25** *Historical Monthly Electricity Use from January 1990 to January 1993 for the Bryan store.*



**Figure 3.26**

*Monthly natural gas consumption for the Bryan store. Gas use for 1990 to 1993 is less than 50 million Btu per month except in peak heating seasons. Heating is only needed for about one month per year. In January, 1992, the gas use was nearly 400 million Btu. Over the past three years, the over-base amount of gas used for heating was an average of 245 million Btu/yr. The use of heat reclaim from the refrigeration system could eliminate the need for gas heating, and would save about \$1,090/yr.*

annual amount of gas used for heating is 245 million Btu/yr. If heat reclaim were used to supply this heating requirement, an estimated \$1,090/yr in natural gas bills could be saved.

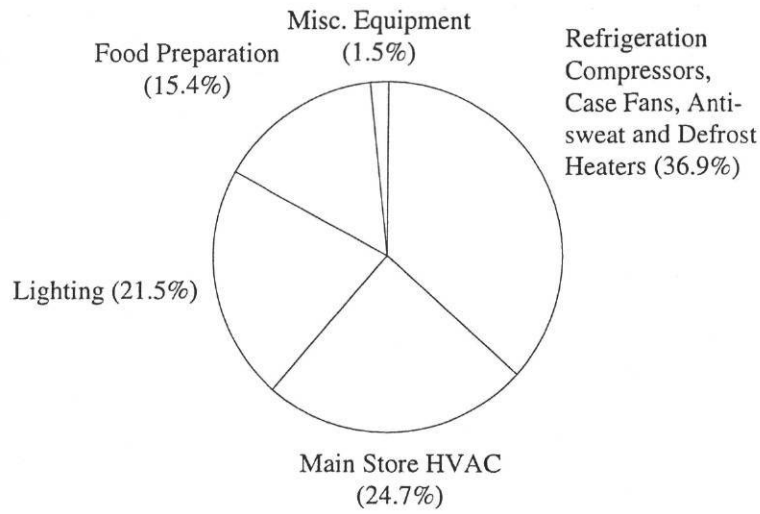
Figure 3.27 (a) shows the breakdown of peak electricity end-uses in the Bryan store based on nameplate power ratings. Figure 3.27 (b) shows a more general breakdown based on four sources of information -- one half year's worth of sub-metered energy use data from the Bryan store, the breakdown given by Schrock (1989) for the College Station store, and the breakdown given by DOE (1981) for the store studied in that reference. Because the descriptions for the loads in the lighting and utility categories overlap to such an extent, they were treated as one category for Figure 3.27 (a and b). Based on the nameplate data, the utility and lighting groups account for 46% of the peak energy use for the Bryan store (compared to 51% for the College Station store). As in the case of the College Station store, the percentage of whole-building energy use attributed to the refrigeration system seems to be overstated by DOE (1981). The nameplate data, sub-metered data, and Schrock's survey all estimate the refrigeration system to use between 30% and 35% of the whole-building electricity, compared to the nearly 40% given by DOE. For the HVAC and lighting and utility categories, the percentages given by the nameplate data, Schrock, and DOE are in fair agreement. However, the sub-metered data seem to understate the contribution due to HVAC (6%), and overstate the contribution due to lighting and utility loads (60%). This is due to the fact that a full year's worth of data was not available; much summertime HVAC load was not included. Also, as discussed in Section 3.6.4, some of the HVAC load is on the utility circuit. Table 3.5 lists the component nameplate loads and their relative percentages of total store electricity use.

### **3.8 ENERGY CONSUMPTION DATA FOR BRYAN STORE**

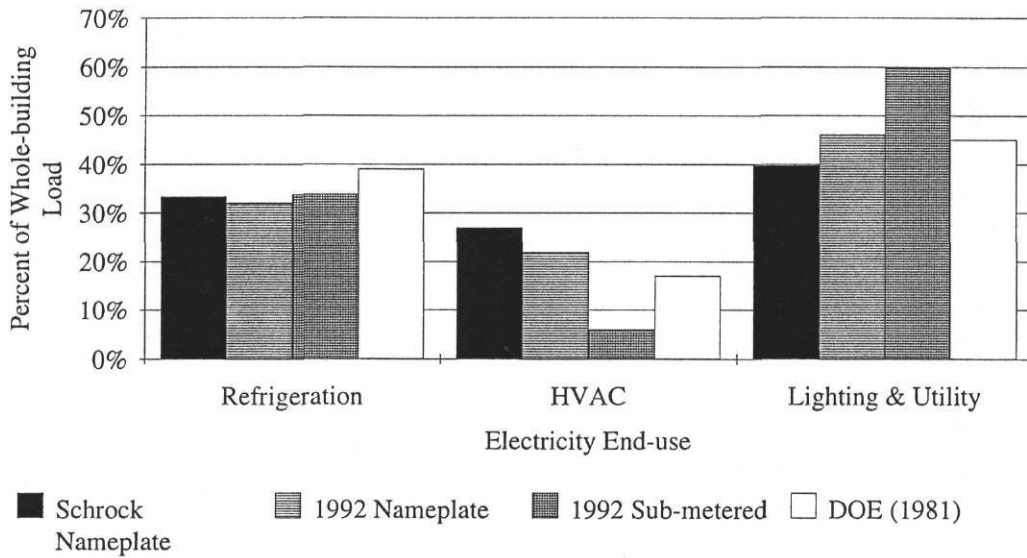
#### **3.8.1 Summary Plots**

The usefulness of energy consumption plots was informally tested by establishing an information loop with the store management. Recorded data were presented the format of weekly summary plots.

Examples of the summary plots are shown in Figure 3.28. The four main loads are plotted with respect to both time and temperature. Ambient hourly weather conditions were provided by a weather station located approximately two miles away, and are plotted along the right edge of the summary page.



(a)



(b)

**Figure 3.27 a,b**

*Percentages of Nameplate Contribution to Peak and Measured Contribution to Electricity Use for the College Station store. (a) End-use contribution based on nameplate data; (b) Contribution based on Schrock (1989), 1992 nameplate survey, 1992 sub-metered data, and DOE (1981) survey.*

TABLE 3.5  
Description of Loads Included in Group Breakdown for the Bryan Store

(a) Schrock (1989)	(b) 1992 Survey Nameplate Peak	(c) 1992 Sub-metered	(d) DOE (1981)
<p><b>Compressors</b> (33%) Refrigeration compressors, condenser fans.</p>	<p><b>Compressors</b> (32%) Refrigeration compressor, condenser and exhaust fans.</p>	<p><b>Compressors</b> (34%) Refrigeration compressor, condenser and exhaust fans.</p>	<p><b>Compressors</b> (39.0%) compressors, condensers, case fans.</p>
<p><b>HVAC</b> (27%) Air-conditioning loads from the two main units.</p>	<p><b>HVAC</b> (22%) Air-conditioning loads from 10 of 12 units.</p>	<p><b>HVAC</b> (6%) Air-conditioning loads from 10 of 12 units.</p>	<p><b>HVAC</b> (17.0%) air-conditioning, fans, electric heat.</p>
<p><b>Lighting and Utility</b> (40) sales area lighting, office, outdoor lights, cash registers, display case lighting, food preparation equipment, case evaporator fans and anti-sweat heaters.</p>	<p><b>Lighting and Utility</b> (46) sales area lighting, office, display case lighting, some receptacles, meat dept. equipment, food prepara- tion, misc. receptacle loads, case fans and anti-sweat heaters, outdoor lights, cash registers, 2 of 12 HVAC units.</p>	<p><b>Lighting and Utility</b> (60) sales area lighting, office, display case lighting, some receptacles, meat dept. equipment, food prepara- tion, misc. receptacle loads, case fans and anti-sweat heaters, outdoor lights, cash registers, 2 of 12 HVAC units.</p>	<p><b>Lighting and Utility</b> (45) sales area, office, and outdoor sign lights.</p>

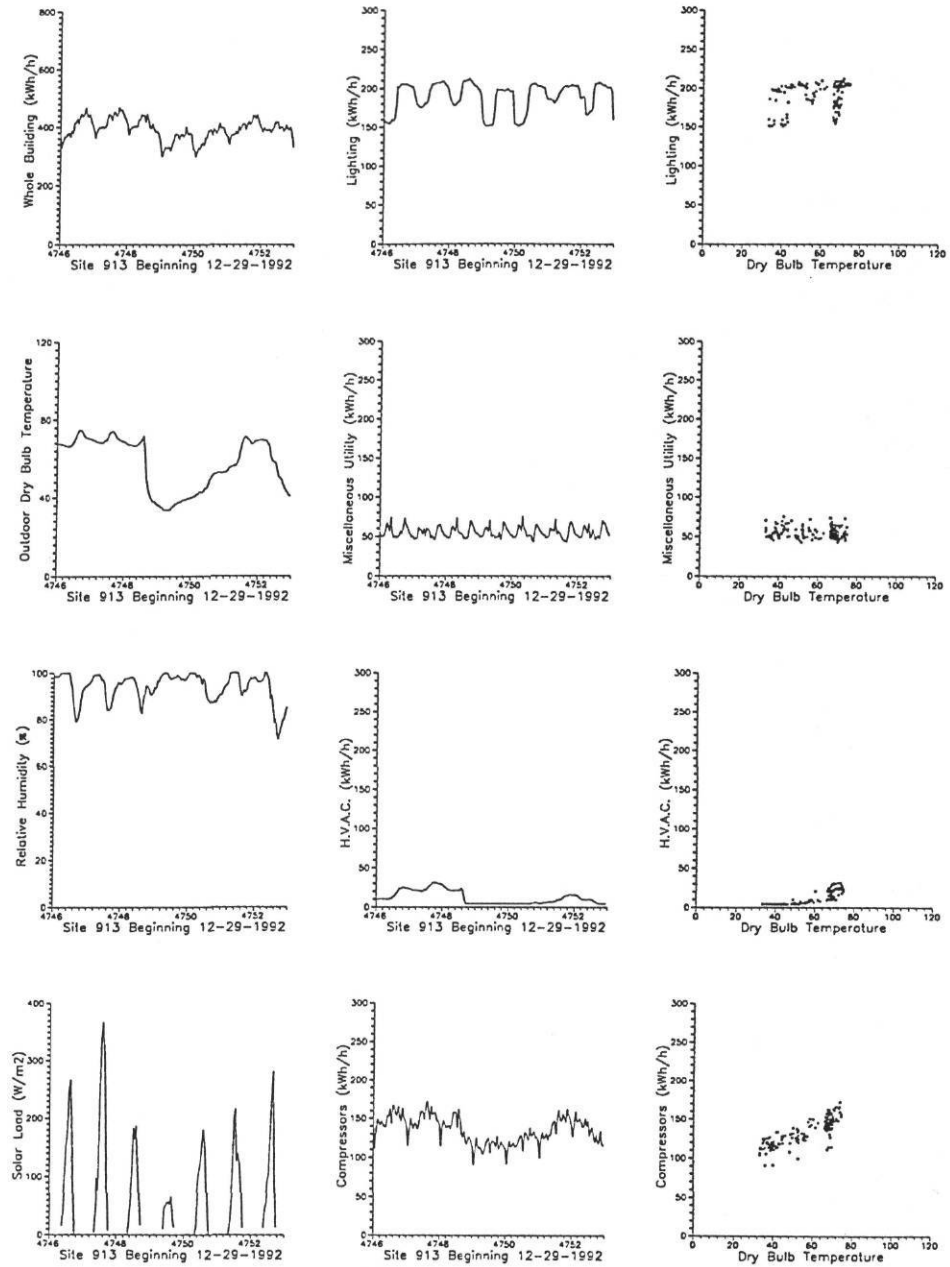


Figure 3.28

Summary inspection plots for Bryan store.

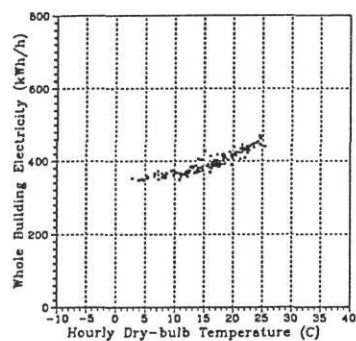


### 3.8.2 Constant and Schedule-dependent Loads

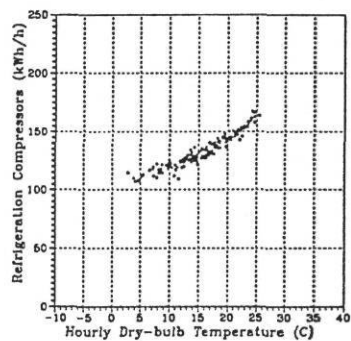
Following the format of the graphical presentation used in the College Station store, scatter plots of the Bryan store whole-building and component electricity loads were made. Figure 3.29 shows plots for daily data which were derived by averaging hourly data. Figure 3.30 shows plots of the hourly data themselves. However, only a half year's worth of data were available -- from 12/20/92 to 6/28/93. Nevertheless, from the plots of half-year data, it is still easy to see which component loads are sensitive to outdoor temperature and which are not. The whole-building data, shown in Figure 3.29 (a) have a strong temperature change-point characteristic. Much the same as for the College Station store, there is a noticeable bend in the curve at about 64°F (18°C). This is a result of the behavior of the temperature-dependent component loads. Both stores have a whole-building load between 350 and 500 kW.

**Lighting and Utility.** The miscellaneous utility load, shown in Figure 3.29 (d), is rather constant below 20°C (67°F), and increases slightly for temperatures above 20°C. This is in contrast to the College Station store, the utility load of which is quite constant over all temperatures. The daily data predict close to the average of the hourly data, shown in Figure 3.30 (d). There are two roof-top HVAC units on the utility circuit. One of them serves a conference room, and is rarely used. The other, representing a load of about 10 kW, serves the manager's office. The energy use of these HVAC units can be seen in the daily utility circuit data when the outdoor temperature is above 20°C (67°F). Apart from the effects of the HVAC units, the daily and hourly Utility data do not vary with respect to outdoor temperature.

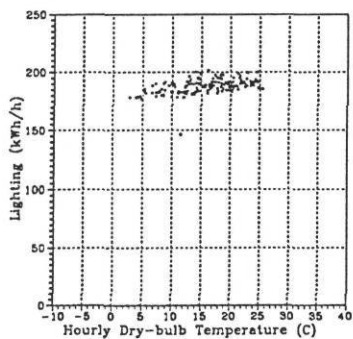
The average value of the daily miscellaneous utility data is 55.5 kWh/h. The maximum nameplate load of utility equipment is 125 kW. But not all of this equipment is connected to the utility circuit; some of it is connected to the lighting circuit. Likewise, some of the loads on the utility circuit are lighting loads. For this reason, for the purposes of further modeling, the lighting and utility loads might be considered as one composite load. Experience with the College Station store suggests that this is a reasonable approach since the lighting and utility loads are considered to be constant base loads for purposes of change-point analyses.



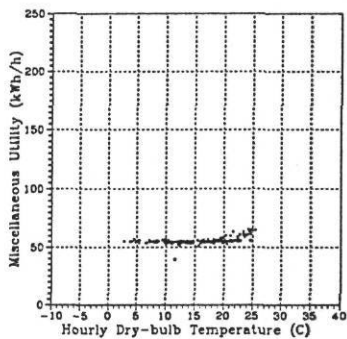
(a)



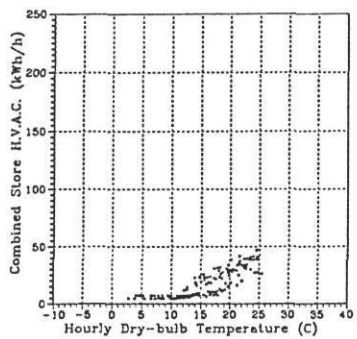
(b)



(c)



(d)



(e)

Figure 3.29 a-e

Scatter Plots of Daily Loads vs. Outdoor Dry-bulb Temperature for the Bryan store.

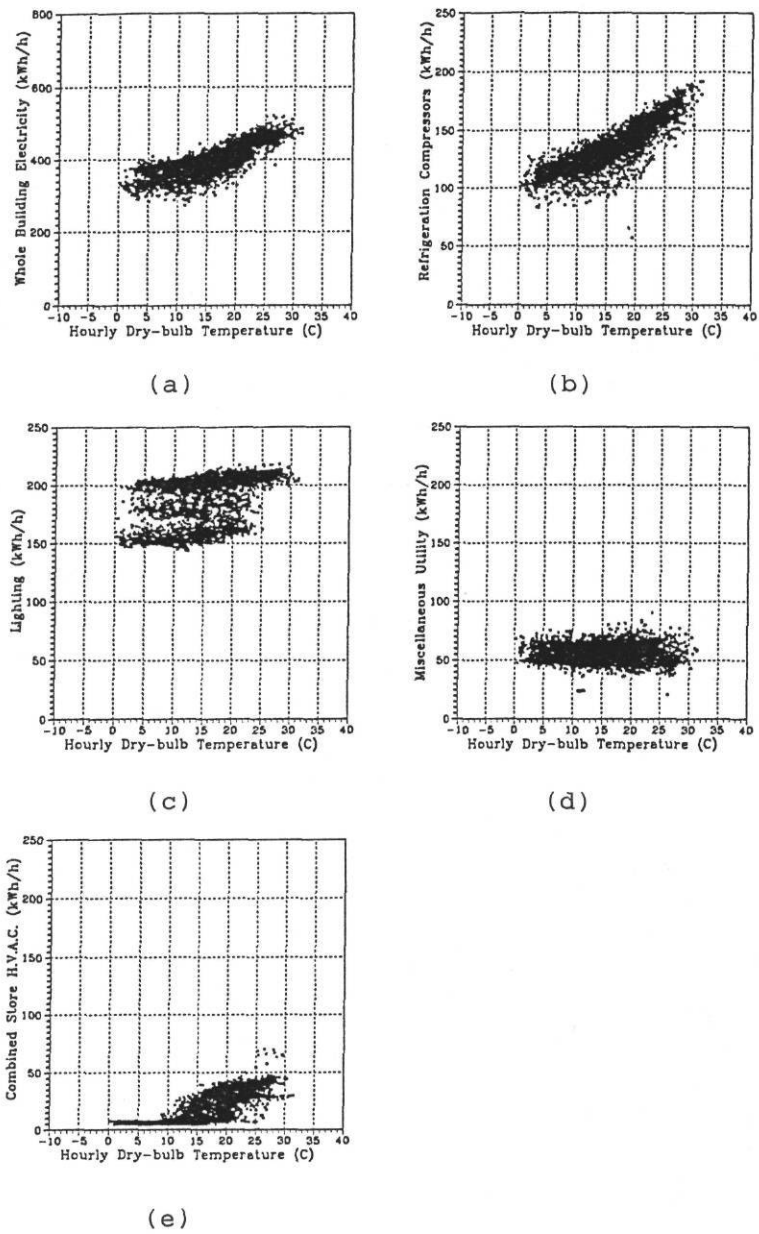


Figure 3.30 a-e

Scatter plots of Hourly Loads vs. Outdoor Dry-bulb Temperature for the Bryan store.

Unlike the College Station store, the lighting circuit does not include the outdoor lights.<sup>23</sup> However, half of the interior lights are turned off from 10:00 p.m. until 8:00 a.m. Thus, in Figure 3.30 (c), two distinct modes of usage may be seen in the hourly lighting data -- one during the early morning when many of the interior lights are off; and one during the day, when only interior lights are on. Figure 3.22, discussed previously, shows the lighting schedule profile for a typical day at the Bryan store.

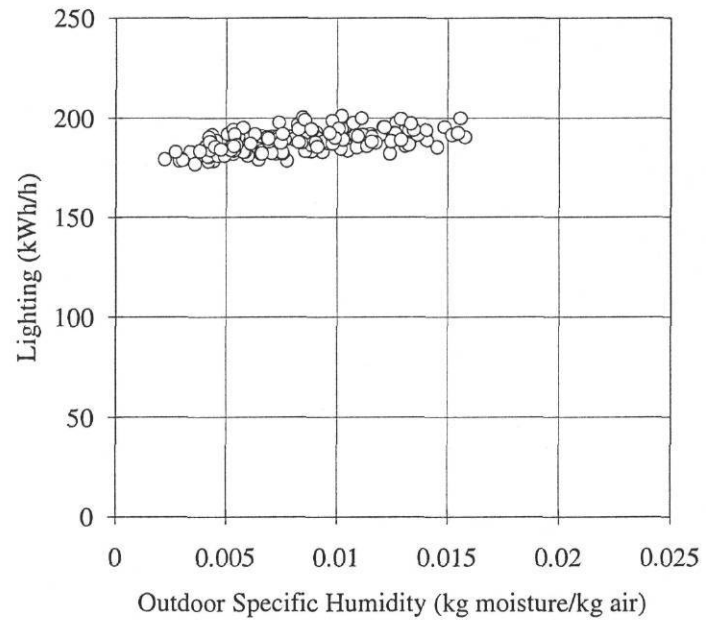
Because the indoor lighting schedule does not change from day to day, nor does it vary with temperature, its variation should not show up in the daily data. For the College Station store, it was the outdoor lights which cause the lighting load to exhibit a slope. Yet, even though the outdoor lights at the Bryan store are not connected lighting circuit, *the daily lighting data do appear to have a slope*. The daily average energy use increases as outdoor temperature increases. One plausible explanation comes when we consider the refrigeration case anti-sweat heaters which are on the lighting circuit. The amount of moisture in the air tends to increase as the days get warmer. This implies a proportional relationship between specific humidity and dry-bulb temperature. Because the Bryan store has no dehumidification in its HVAC system, an increase in outdoor temperature and humidity may be creating an increase in indoor humidity. The case anti-sweat must run longer and more often in order to counter the increased latent load on the case doors and cooling coils.<sup>24</sup> Compounding this effect is the fact that during the hotter and more humid seasons, customers may be purchasing more frozen goods, thus increasing the duty factor on the display cases, and thereby increasing the amount of moisture which collects on the doors. Figure 3.31 shows the daily average lighting load plotted with respect to outdoor specific humidity. A slight increase may be seen as humidity increases.

**Refrigeration.** Refrigeration compressor loads seem to be linearly related to outdoor air temperature, with only a slight change-point at about 16°C (61°F). The reasons for the temperature dependency have already been discussed in Section 3.4.3. The refrigeration capacity for the Bryan store is similar to that for the College Station

---

<sup>23</sup> They are connected to the store's miscellaneous utility circuit. Note the 20 kW step seen in Figure 3.NEW.23 caused by the parking lot lights switching on and off.

<sup>24</sup> Conversations with the chief facilities engineer indicated that it was likely that some of the anti-sweat case door heaters were controlled by humidity sensors in the doors.



**Figure 3.31**

*Lighting load versus outdoor specific humidity for the Bryan store.*

stores. However, the Bryan HVAC system does not use heat reclaim; therefore, there is no bimodal pattern in the refrigeration compressor load. There is, however, a slight change-point in the compressor data. Regression analysis of the type used by Ruch and Claridge (1991) determined this change-point to be 16°C (61°F). As described in Section 3.6.1, the fans in the compressor room control the room air temperature, and do not let it drop below 16°C (61°F). This means that outdoor air temperatures below 16°C do not have as much effect on compressor energy use by way of the condenser coils which are inside the compressor room. The fact that we nevertheless see a slight temperature-dependency for outdoor temperatures below 60°F means that the compressor room is never completely shut off from the outdoor air. This could mean either than the exhaust fan controls are not functioning properly, or that due to the amount of heat generated in the compressor room, the room temperature is always higher than 60°F, thus never allowing the fans to shut off.

**HVAC.** Ten of the twelve roof-top HVAC units are monitored as part of the HVAC data. They represent 89% of the 183 kW of connected HVAC capacity. These HVAC data are displayed in Figure 3.29 (e) and Figure 3.30 (e). We have accumulated six months of hourly and daily data on these systems. While this is not a full year's worth, it is enough to give some indication of a change-point characteristic in the HVAC system. This can be seen in both the hourly and daily data. The maximum load observed so far is about 90 kW. Because there is no dehumidification, there is no cooling load during very low outdoor temperatures (below about 50°F [10°C]). Below this temperature, only fan loads (5 to 10 kWh/h) exist. The store management claims that the fact that there is no dehumidification results in unsatisfactory indoor air quality conditions. The Bryan store HVAC system is representative of systems in stores acquired by the retail company -- rather than those constructed by it. Stores constructed by the company have central HVAC systems like the one at the College Station store.

### 3.9 SUMMARY

The annual energy use for the College Station store in the years since 1990 is significantly different than that reported in the multi-store survey in Chapter 2. The energy use from 1991 onward include the loads of the video store. In general, energy use has increased since the annexation of the video store, while energy use intensities have decreased. Average values for each period are shown below:

College Station store	Before video store Period of 1990	After video store Period of 1991-1992
Electricity use	3,215,000 kWh/yr	3,611,000 kWh/yr
Electricity EUI	8 W/ft <sup>2</sup> (86 W/m <sup>2</sup> )	7.5 W/ft <sup>2</sup> (81 W/m <sup>2</sup> )
Gas use	819 million Btu/yr	851 million Btu/yr
Gas EUI	17,700 Btu/ft <sup>2</sup> ·yr (191,000 Btu/m <sup>2</sup> ·yr)	15,400 Btu/ft <sup>2</sup> ·yr (166,000 Btu/m <sup>2</sup> ·yr)

The annual energy use for the Bryan store has remained fairly constant over the years. Average values for each period are as follows:

Bryan Store	Period of 1990	Period of 1991-1992
Electricity use	3,751,000 kWh/yr	3,884,000 kWh/yr
Electricity EUI	8.8 W/ft <sup>2</sup> (95 W/m <sup>2</sup> )	9.1 W/ft <sup>2</sup> (98 W/m <sup>2</sup> )
Gas use	712 million Btu/yr	734 million Btu/yr
Gas EUI	14,600 Btu/ft <sup>2</sup> ·yr (157,000 Btu/m <sup>2</sup> ·yr)	15,000 Btu/ft <sup>2</sup> ·yr (161,000 Btu/m <sup>2</sup> ·yr)

Due to time constraints, the Bryan store could not be studied as thoroughly as the College Station store. This work may be left for future research. However, the following are general conclusions about both case study grocery stores surveyed in this report.

- 1) The sub-metering of component electricity loads in the College Station store proved useful in making the store management aware of operational and maintenance problems. In this study, the feedback was handled manually; however, it is expected that automated methods could have easily provided similar information. Problems such as lighting shut-off were spotted quickly through the feedback process.
- 3) For this study, peak nameplate and survey readings for electricity loads were moderately good proxies for sub-metered end-use loads insofar as *relative percentages* of energy use are concerned, though they tended to over estimate the contribution due to miscellaneous utility loads which do not run at all times.

- 4) Simple scatter plots of electricity use versus outdoor temperature were useful in gauging the temperature-dependency of certain component loads. They also provided a visual means of comparing the component loads to each other and to whole-building electricity use.
- 5) Daily data were found to be good indicators of the patterns of hourly electricity use in the case study store for all loads except lighting which exhibits strong time-of-day characteristics.

In specific, we note the following:

- 6) The lighting systems of both stores are comparable. The College Station store has 142 kW of indoor lighting, amounting to 2.6 W/ft<sup>2</sup> (28 W/m<sup>2</sup>). The Bryan store has 138 kW of indoor lighting, amounting to 2.8 W/ft<sup>2</sup> (30 W/m<sup>2</sup>).
- 7) In both stores, refrigeration and HVAC loads were found to be dependent on outdoor temperature, while lighting and miscellaneous utility loads were not.
- 8) Both the College Station and Bryan stores have refrigeration and HVAC loads that are temperature-dependent.
- 9) Both stores have change-points in whole-building, HVAC, and refrigeration loads. The refrigeration systems of both stores exhibit a change-point temperature at about 60°F (16°C).
- 10) The College Station store employs heat reclaim from the refrigeration system. As a result, the refrigeration energy use exhibits a bimodal characteristic below the change-point temperature.
- 11) The most significant difference between the two stores is in their HVAC systems. The Bryan store lacks heat reclaim and dehumidification, and uses natural gas for heating.
- 12) The College Station store uses about 851 million Btu/yr, or 15,400 Btu/ft<sup>2</sup>·yr or natural gas whereas the Bryan store uses about 690 million Btu/yr, or 14,200 Btu/ft<sup>2</sup>·yr. Nevertheless, the Bryan store's peak gas use is significantly higher than that of the College Station store due to the fact that it uses gas for space heating.



## CHAPTER IV

### CP/PCA AND CP/MLR MODELING

This chapter presents the results of the comparison of two modeling techniques -- multiple linear regression (MLR) and principal component analyses (PCA) - for one year's worth of whole-building data from the College Station grocery store. First, the 1989 MLR and PCA grocery store models developed by Ruch et al (1991) are discussed. Pre-analysis adjustments to the 1992 data are then reviewed. Next, the results of the MLR and PCA analysis of the 1992 energy data are presented and compared to the 1989 models. Finally, the 1992 whole-building models are compared with component refrigeration and HVAC models and with building energy use predictions based on standard ASHRAE<sup>1</sup> diversified load calculation methods, outlined in Knebel (1983), to determine whether MLR or PCA analysis gives parameters which are more physically meaningful.

#### 4.1 BACKGROUND

Ruch et al. (1991) developed a change-point/principal component (CP/PCA) model for the electricity use for the case-study store prior to the annexation of the video rental store (1989 data). They concluded that the CP/PCA model, with one primary component removed, provided more stable parameter estimates than did the corresponding MLR model.

In order to test the usefulness of the Ruch et al. MLR and PCA 1989 models, they were used with 1992 weather and sales data to predict the 1992, total daily energy consumption. Independent variables used were outdoor dry-bulb temperature ( $^{\circ}\text{C}$ ), outdoor specific humidity (kg moisture/kg air), solar radiation ( $\text{W}/\text{m}^2$ ), and sales ( $\text{\$/day}$ ).

Unfortunately, the store's energy use has changed since 1989. This change occurred with the addition of a video rental store (containing loads HVAC and lighting) and two new dairy compressors which introduced loads that Ruch's 1989 data set models could not predict. Therefore, before the analyses and comparisons could be

---

<sup>1</sup> American Society of Heating, Refrigeration, and Air-conditioning Engineers

performed, it was necessary to subtract estimates of the energy use of the video store and dairy compressors from the 1992 whole-building data.

Two 7.5-ton video store HVAC units, described in Chapter 3, were sub-metered separately, and their energy use could easily be subtracted from the whole-building electricity use data. However, the energy use of the third 7.5-ton unit and the two 5-ton units was included in the whole-building HVAC data. This required that an estimation of their energy use be subtracted from the main store's electricity data. According to store maintenance personnel, one 5-ton unit was disconnected during the spring of 1992 due to mechanical problems, and is no longer used. With no other information available, the EER ratings of the AC units were assumed to be the same. Thus, the ratios of their electricity energy consumptions were assumed to be proportional to the ratios of their rated cooling capacities (tons). Based on this assumption, the total video store HVAC load was estimated to be 1.83 times the sub-metered load of the two 7.5-ton units.

The lighting load was estimated in a lighting count to be 29.6 kW. Because the lights are not on 24 hours per day, this value was modified to a constant 21.4 kW to account for scheduling effects. The loads of the two new refrigeration compressors were measured in a walk-through survey along with the other refrigeration compressors. These accounted for about 9.1% of the remaining, sub-metered refrigeration load. One assumption in this adjustment procedure was that the variations in the new HVAC and refrigeration loads were proportional to those of the corresponding systems in the main store which existed at the time of the Ruch et al. study.

The estimations of the new loads were subtracted from the whole-building consumption data set. From a simple linear regression of the adjusted 1992 data, a simple 4-parameter change-point model was identified. The adjusted 1992 model, the unadjusted 1992 model, and the 1989 model are as follows:

$$E_{\text{adjusted,1992}} = 331.3 + 2.87(T - 18.7^\circ\text{C})^- + 7.62(T - 18.7^\circ\text{C})^+ \quad (4.1a)$$

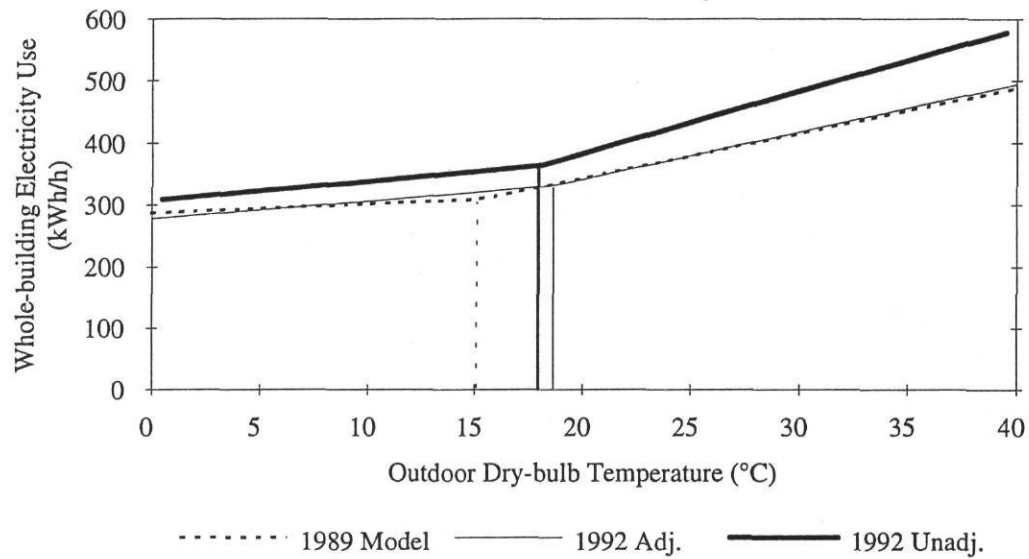
$$E_{\text{unadjusted,1992}} = 363.5 + 3.01(T - 18.01^\circ\text{C})^- + 9.75(T - 18.01^\circ\text{C})^+ \quad (4.1b)$$

$$E_{1989} = 310.8 + 1.49(T - 15.4^\circ\text{C})^- + 7.22(T - 15.4^\circ\text{C})^+ \quad (4.1c)$$

where  $T$  is the outdoor ambient dry-bulb temperature, ( $^{\circ}\text{C}$ ). Energy use in is kilowatt-hours per hour. The superscript  $-$  indicates that the term to which it is applied is only applicable when it is negative, and zero at all other times. Similarly, the superscript  $+$  indicates that the term to which it is applied is only applicable when it is positive, and zero at all other times.

Figure 4.1 shows the three four-parameter whole-building electricity models which predict consumption based on outdoor temperature. One model was developed by Ruch and Claridge (1991) from 1989 daily data; the second is the model identified from adjusted 1992 data; the third is the model identified from the unadjusted 1992 data. There is a noticeable difference between the 1989 and unadjusted 1992 models, implying a difference in the data. The electricity use is higher in 1992 than in 1989, and the change-point temperature has changed from  $15.4^{\circ}\text{C}$  ( $59^{\circ}\text{F}$ ) to  $18.7^{\circ}\text{C}$  ( $65^{\circ}\text{F}$ ). However, adjusting the 1992 data yielded a model which agreed with the 1989 model predictions to within 3.5%. It is difficult to accurately estimate the effect this has on the change-point of the data themselves. The adjusted 1992 data have a change-point of  $18.7^{\circ}\text{C}$  ( $65^{\circ}\text{F}$ ) rather than  $15.4^{\circ}\text{C}$  ( $59^{\circ}\text{F}$ ). It is worth noting that Ruch and Claridge used only 191 data points, whereas 359 were available for the development of the 1992 models. This may also be contributing to the difference in change-points. There were no other physical changes to the store between 1989 and 1992 other than those already considered. But while the model change-points vary, the data-adjustment approach sufficiently demonstrates that adding the estimated loads of the video store lighting, HVAC, and the new dairy compressors to the 1989 data helps to explain the difference between the 1989 and 1992 whole-building consumption data. Thus, these new load estimates were subtracted from the whole-building consumption data before multivariate MLR and PCA models were developed and compared to each other.

After the 1992 data were adjusted to 1989 building conditions, climate and sales data for 1992 was compared to that of 1989. The correlations between the variables of daily average temperature, specific humidity, solar radiation, and sales for each of the two periods are shown in Figure 4.2. Correlations between independent and dependent variables for the 1992 data are shown in Table 4.1a and Table 4.1b.



**Figure 4.1**

*1989 and 1992 models of whole-building electricity data. Estimates of the video store HVAC and lighting loads, and new dairy compressor loads were subtracted from the 1992 whole-building data which were modeled to predict whole-building electricity use within 5.1% of the 1989 model predictions. This technique will be used in adjusting the 1992 data for PCA and MLR modeling.*

TABLE 4.1a  
Correlation Matrix for Old 1989 Data Set (all data)

---

	temp	SH	solar	sales	elec
temp	1	0.816	0.443	-0.090	0.935
SH		1	0.0738	-0.198	0.807
solar			1	0.0122	0.443
sales				1	-0.0839
elec					1

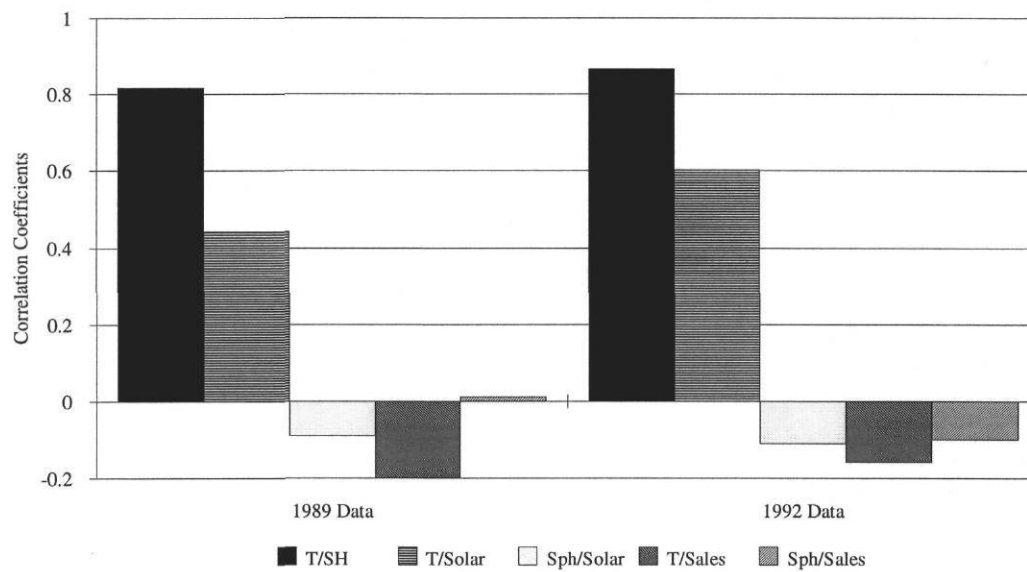
---

TABLE 4.1b  
Correlation Matrix for New 1992 Data Set (all data)

---

	temp	SH	solar	sales	elec
temp	1	0.865	0.597	-0.0946	0.932
SH		1	0.245	-0.129	0.855
solar			1	-0.115	0.575
sales				1	-0.104
elec					1

---



**Figure 4.2**

*Pearson Correlation Coefficients.  
The relationships between the climate variables in 1989 and 1992 have remained similar.*

Reddy and Claridge (1993) concluded that PCA should do a better job at identifying the true parameters of the model than MLR if either:

- a) *one or more* pair of regressor variables has correlation coefficients of 0.5 or higher, *and* the model  $R^2$  value is less than about 0.5.

or,

- b) *only one* pair of regressor variables has correlation coefficients of 0.8 or higher, regardless of the model  $R^2$  value.

As can be seen in Table 4.1b, Reddy and Claridge's case (b) applies to the 1992 data when the whole year is considered. However, like MLR, PCA is a linear modeling technique. Because the data exhibit a non-linear characteristic due to the change-point operation of the HVAC and refrigeration systems, it was appropriate to perform a piece-wise regression on the data as Ruch did. When this was done, the correlations between the regressor variables changed (see Tables 4.2-4.5).

The largest correlation between regressor variables for the 1992 data above the change-point was 0.759. This is close to Reddy's criterion of 0.8, though the  $R^2$  value of the MLR and PCA models, above change-point, was high (above 0.8). This data set fits Reddy and Claridge's case (b).

However, for the 1992 data below the change-point, the largest correlation between regressor variables was about -0.580, followed closely by -0.489. The  $R^2$  values for the below change-point MLR and PCA models did not exceed 0.503. This data set seems to fit case (a).

There was, therefore, some reason to believe that PCA methods would yield more realistic models than MLR. But the physical significance of the parameter coefficients would have to be tested.

TABLE 4.2  
Correlation Matrix for 1989 Data set above CP of 15.4°C (59°F)

	temp	SH	solar	sales	elec
temp	1	0.653	0.347	-0.0723	0.855
SH		1	-0.212	-0.245	0.626
solar			1	0.0358	0.320
sales				1	-0.0727
elec					1

TABLE 4.3  
Correlation Matrix for New 1992 Data set above CP of 18.7°C (65°F)

	temp	SH	solar	sales	elec*
temp	1	0.759	0.540	-0.184	0.923
SH		1	-0.00153	-0.206	0.723
solar			1	-0.121	0.459
sales				1	-0.156
elec					1

\* electricity adjusted to remove effect video store and new dairy compressors



TABLE 4.4  
Correlation Matrix for 1989 Data set below CP of 15.4°C (59°F)

	temp	SH	solar	sales	elec
temp	1	0.581	0.0358	-0.181	0.657
SH		1	-0.376	-0.296	0.419
solar			1	0.225	0.191
sales				1	0.561
elec					1

TABLE 4.5  
Correlation Matrix for New 1992 Data set below CP of 18.7°C (65°F)

	temp	SH	solar	sales	elec
temp	1	0.580	0.244	0.0700	0.701
SH		1	-0.489	0.0614	0.492
solar			1	-0.0654	0.197
sales				1	0.0960
elec					1

## 4.2 MODEL IDENTIFICATION

### 4.2.1 Above-CP Region

The 1989 MLR and PCA models developed by Ruch et al., were tested by seeing how well they could predict the electricity consumption for the adjusted 1992 data set. Tables 4.6 and 4.7 show the eigenvector matrices used to translate from the original variables to principal components for the above-change-point region. Model parameters are shown in Tables 4.8 and 4.9.

**1989 Models.** The 1989 MLR and 2-PC PCA models for whole-building electricity use (kWh/day) above the change point of (15.4 °C [59°F]) were,

$$\begin{aligned}
 E_{\text{MLR}} = & \quad 129.08 \cdot (\text{Temp } ^\circ\text{C}) \\
 & + \quad 1.48 \cdot (\text{Solar W/m}^2) \\
 & + \quad 36001 \cdot (\text{Spec.Hum. kg w/kg a}) \\
 & + \quad 5133.27
 \end{aligned} \tag{4.2a}$$

$$\begin{aligned}
 E_{\text{PCA}} = & \quad 98.82 \cdot (\text{Temp } ^\circ\text{C}) \\
 & + \quad 2.55 \cdot (\text{Solar W/m}^2) \\
 & + \quad 59227 \cdot (\text{Spec.Hum. kg w/kg a}) \\
 & + \quad 5423.48
 \end{aligned} \tag{4.2b}$$

**1992 Models.** The new CP/PCA and CP/MLR models developed from the 1992 data above the change point (18.7°C [65°F]) were,

$$\begin{aligned}
 E_{\text{MLR}} = & \quad 194.02 \cdot (\text{Temp } ^\circ\text{C}) \\
 & - \quad 0.6352 \cdot (\text{Solar W/m}^2) \\
 & - \quad 2950 \cdot (\text{Spec.Hum. kg w/kg a}) \\
 & + \quad 4432
 \end{aligned} \tag{4.3a}$$

$$\begin{aligned}
 E_{\text{PCA}} = & \quad 92.7 \cdot (\text{Temp } ^\circ\text{C}) \\
 & + \quad 2.216 \cdot (\text{Solar W/m}^2) \\
 & + \quad 77587 \cdot (\text{Spec.Hum. kg w/kg a}) \\
 & + \quad 5281
 \end{aligned} \tag{4.3b}$$

TABLE 4.6

Eigenvectors for 1989 PCA Model above CP of 15.4°C (59°F)

	PC #1	PC #2	PC #3
Temp	0.731873	0.177551	-0.657903
SH	0.659932	-0.425325	0.619345
Solar	0.169857	0.887454	0.428456
R <sup>2</sup> Contribution	0.7158	0.0245	0.0088
Eigenvalue	1.66896	1.17136	0.15967
Variance Rank	55.6%	39.1%	5.3%

TABLE 4.7

Eigenvectors for 1992 PCA Model above CP of 18.7°C (65°F)

	PC #1	PC #2	PC #3
Temp	0.709840	0.005377	-0.704342
SH	0.575892	-0.580190	0.575958
Solar	0.405556	0.814463	0.414939
R <sup>2</sup> Contribution	0.8217	0.001638	0.03151
Eigenvalue	1.92475	1.01450	0.06075
Variance Rank	64.2%	33.8%	2%

TABLE 4.8  
 Regression Summary: 1989 Models as Used on 1992 Whole-building Data  
 Above CP of 15.4°C (59°F)

Model Parameters:	PCA Model 1 PCs 1,2,3	PCA Model 2 PCs 1,2	MLR Model
Temp (°C)	-----	98.82	129.08
standard error	-----	-----	16.74
SH (kg w/kg a)	-----	59227	36001
standard error	-----	-----	13098
Solar (W/m <sup>2</sup> )	-----	2.55	1.48
standard error	-----	-----	0.71
Constant	-----	5423.48	5133.27
standard error	-----	-----	525.05
PC#1	482.20	482.20	-----
standard error	27.86	28.21	-----
PC#2	106.41	106.41	-----
standard error	33.26	33.68	-----
PC#3	-172.59	-----	-----
standard error	90.08	-----	-----
PCA Constant	9349.12	9349.12	-----
standard error	35.83	36.28	-----
Model R <sup>2</sup>	0.7490	0.7403	0.7490
Model RMSE	374.08	378.76	374.08
% of variation explained	100	94.67	100

TABLE 4.9  
 Regression Summary: 1992 Models as Used on 1992 Whole-building Data  
 Above CP of 18.7°C (65°F)

Model Parameters:	Model 1 PCs 1,2,3	Model 2 PCs 1,2	MLR Model -----
Temp (°C)	-----	92.7	194.02
standard error	-----	-----	14.67
SH (kg w/kg a)	-----	77587	-2950.3
standard error	-----	-----	11993
Solar (W/m <sup>2</sup> )	-----	2.216	-0.6352
standard error	-----	-----	0.4562
Constant	-----	5281	4432.1
standard error	-----	-----	161.3
PC#1 standard error	440.4	440.4	-----
	12.29	13.53	-----
PC#2 standard error	-27.09	-27.09	-----
	16.93	18.63	-----
PC#3 standard error	-485.47	-----	-----
	69.17	-----	-----
PCA Constant	9042.97	9042.97	-----
standard error	17.01	18.73	-----
Model R <sup>2</sup>	0.85	0.82	0.85
Model RMSE	258.55	284.61	258.55
% of variation explained	100	98	100

#### 4.2.2 Below-CP Region

Tables 4.10 and 4.11 show the eigenvector matrices used to translate from the original variable to principal components for the below-change-point region.

TABLE 4.10  
Eigenvectors for 1989 PCA Model below CP of 15.4°C (59°F)

	PC #1	PC #2	PC #3
Temp	0.627589	-0.341589	0.699607
SH	0.633805	-0.297694	-0.713912
Solar	0.452133	0.891457	0.029671
R <sup>2</sup> Contribution	0.4870	0.02830	0.07440
Eigenvalue	1.78128	0.79967	0.41905
Variance Rank	59.4%	26.7%	14.0%

TABLE 4.11  
Eigenvectors for 1992 PCA Model below CP of 18.7°C (65°F)

	PC #1	PC #2	PC #3
Temp	0.699205	-0.101588	-0.707667
SH	0.698077	-0.116589	0.706467
Sales	0.154274	0.987971	0.010603
R <sup>2</sup> Contribution	0.4508	0.001146	0.05171
Eigenvalue	1.59464	0.98557	0.41980
Variance Rank	58.0%	32.9%	14.0%

**1989 Models.** Below the change-point of 15.4°C (59°F), Ruch had,

$$\begin{aligned}
 E_{\text{MLR}} &= && 53.93 \cdot (\text{Temp } ^\circ\text{C}) \\
 &+ && 0.00496 \cdot (\text{Sales } \$/\text{day}) \\
 &- && 4182 \cdot (\text{Spec.Hum. kg w/kg a}) \\
 &+ && 6376
 \end{aligned} \tag{4.4a}$$

$$\begin{aligned}
 E_{\text{PCA}} &= && 59.65 \cdot (\text{Temp } ^\circ\text{C}) \\
 &+ && 0.00296 \cdot (\text{Sales } \$/\text{day}) \\
 &+ && 5348 \cdot (\text{Spec.Hum. kg w/kg a}) \\
 &+ && 6381
 \end{aligned} \tag{4.4b}$$

**1992 Models.** The 1992 models below the change-point (18.7°C [65°F]) yielded:

$$\begin{aligned}
 E_{\text{MLR}} &= && 61.10 \cdot (\text{Temp } ^\circ\text{C}) \\
 &+ && 0.001804 \cdot (\text{Sales } \$/\text{day}) \\
 &+ && 18744 \cdot (\text{Spec.Hum. kg w/kg a}) \\
 &+ && 6565
 \end{aligned} \tag{4.5a}$$

$$\begin{aligned}
 E_{\text{PCA}} &= && 60.76 \cdot (\text{Temp } ^\circ\text{C}) \\
 &+ && 0.003166 \cdot (\text{Sales } \$/\text{day}) \\
 &+ && 18157 \cdot (\text{Spec.Hum. kg w/kg a}) \\
 &+ && 6507
 \end{aligned} \tag{4.5b}$$

Model parameters are shown in Tables 4.12 and 4.13. We note here that 1989 model parameters and their corresponding 1992 model parameters agree much more closely for the PCA models than for the MLR models.

TABLE 4.12  
 Regression Summary: 1989 Models as Used on 1992 Whole-building Data  
 Below CP of 15.4°C (59°F)

Model Parameters:	Model 1: PCs 1,2,3	Model 2: PCs 1,3	MLR Model:
Temp (°C)		59.65	53.93
standard error		-----	17.12
SH (kg w/kg a)		5347.85	- 4182
standard error		-----	29125
Sales (\$/day)		0.00296	0.00496
standard error		-----	0.00180
Constant		6381.18	6375.56
standard error		-----	440.61
PC#1	118.74	118.74	-----
standard error	24.37	24.59	-----
PC#2	42.72	-----	-----
standard error	36.37	-----	-----
PC#3	95.74	95.74	-----
standard error	50.24	50.69	-----
PCA Constant	7269.51	7269.51	-----
standard error	31.84	32.13	-----
Model R <sup>2</sup>	0.5898	0.5615	0.5898
Model RMSE	155.97	157.38	155.97
% of variation explained	100	73.34	100



TABLE 4.13  
 Regression Summary: 1992 Models as Used on 1992 Whole-building Data  
 Below CP of 18.7°C (65°F)

Model Parameters:	Model 1 PCs 1,2,3	Model 2 PCs 1,3	MLR Model
Temp (°C)	----	60.76	61.10
standard error	----	----	7.62
SH (kg w/kg a)	----	18158	18744
standard error	----	----	11450
Sales (\$/day)	----	0.003166	0.001804
standard error	----	----	0.002565
Constant	----	6564	6631.17
standard error	----	----	166.75
PC#1	210.19	210.19	----
standard error	19.81	19.73	----
PC#2	-13.48	----	----
standard error	25.19	----	----
PC#3	-138.75	-138.75	----
standard error	38.6	38.5	----
PCA Constant	7677.08	7677.08	----
standard error	24.84	19.49	----
Model R <sup>2</sup>	0.503	0.502	0.503
Model RMSE	281.9	281.0	281.9
% of variation explained	100	66	100

### 4.3 MODEL COMPARISON: PCA VS. MLR

Figures 4.3-4.6 are scatter plots of the MLR and PCA models, 1992 adjusted data, and residuals versus temperature. When used to predict 1992 daily electricity consumption, the 1989 CP/PCA model has an  $R^2$  value of 92%, and a CV of 4.1%, as compared to the MLR model, which has an  $R^2$  value of 91%, and a CV of 4.4% (see Table 4.14). It is interesting to note that when Ruch evaluated his models by using the 1989 data from which they were derived, the PCA model had a lower  $R^2$  value than the MLR model, and a higher CV. However, when the models are used to predict data from which they were not derived, the PCA model is the better predictor.

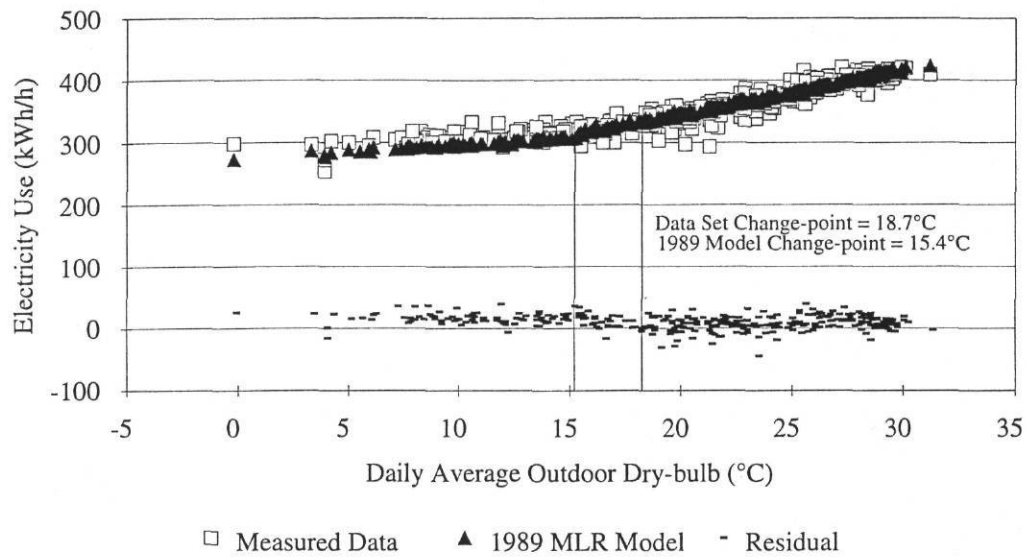
TABLE 4.14  
Summary of Performance of Models over 1992 Data Set

	Measured*	1989 MLR	1989 PCA	1992 MLR	1992 PCA
Avg kWh/day	8,507	8,479	8,543	8,496	8,504
kWh/yr	3,054,013	3,043,942	3,066,983	3,049,992	3,052,848
$R^2$ (%)	----	91	92	95	95
CV (%)	----	4.4	4.1	3.2	3.3

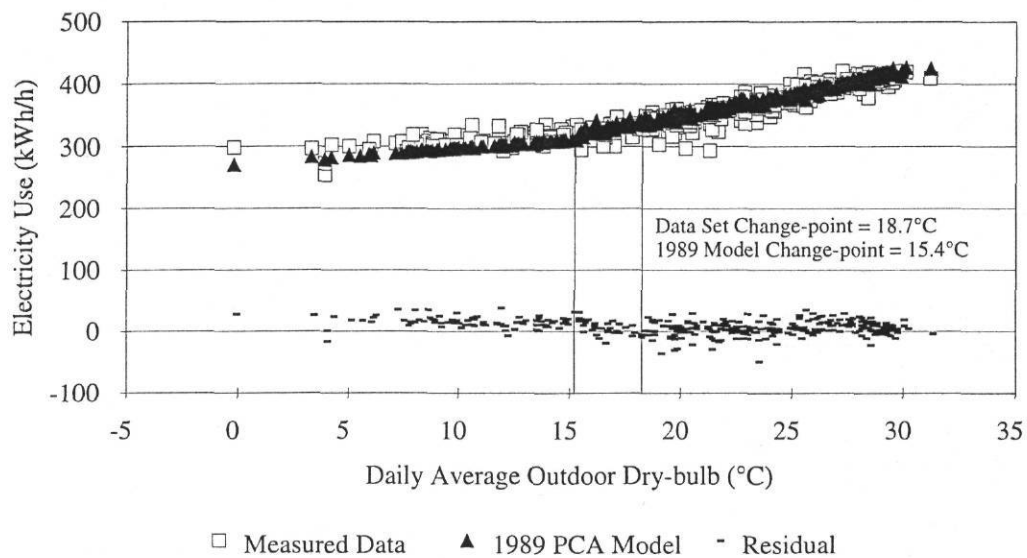
\* adjusted

When used to predict 1992 daily electricity consumption, the 1992 CP/PCA model had an  $R^2$  value of 95%, and a CV of 3.3%, as compared to the MLR model, which had an  $R^2$  value of 95%, and a CV of 3.2%. The new models have slightly better  $R^2$  values and CVs than the 1989 models. Part of this is to be expected since they were developed from the 1992 data.

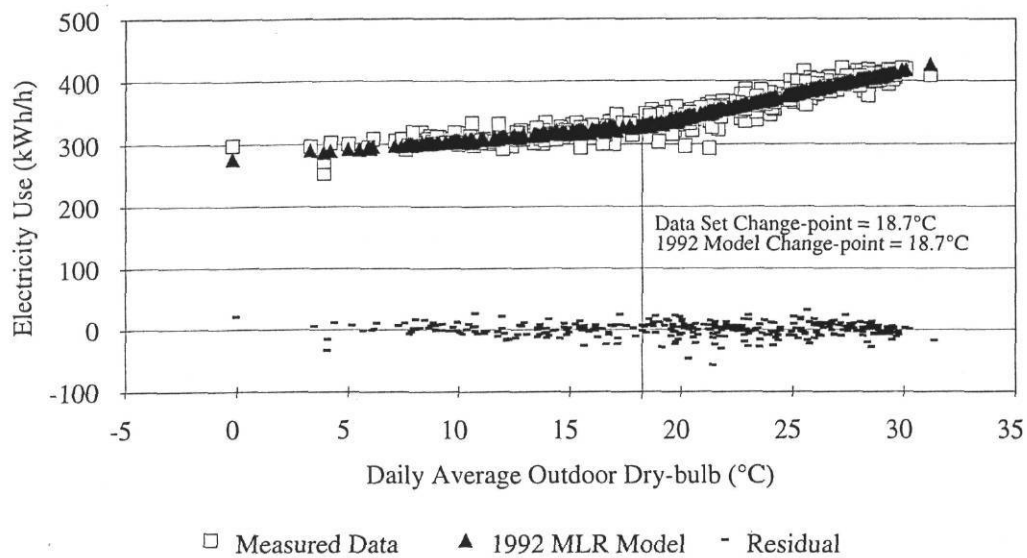
For data above and below the change-point, the 1989 and 1992 PCA model parameters agreed much more closely than did the MLR model parameters. Table 4.15 shows the differences between the MLR parameters, for temperatures above the change-point, from 1989 to 1992.



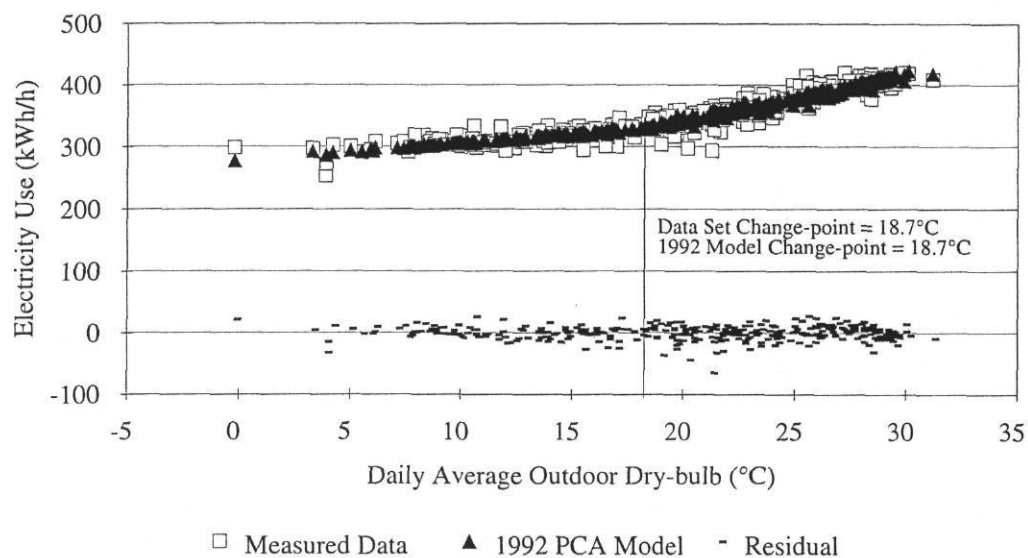
**Figure 4.3**      *Scatter Plot of 1989 MLR Model Predictions and 1992 Measured Data.*



**Figure 4.4**      *Scatter Plot of 1989 PCA Model Predictions and 1992 Measured Data.*



**Figure 4.5**      *Scatter Plot of 1992 MLR Model Predictions and 1992 Measured Data.*



**Figure 4.6**      *Scatter Plot of 1992 PCA Model Predictions and 1992 Measured Data.*

TABLE 4.15  
Percent Differences in Model Parameters for 1989 and 1992 Models\*

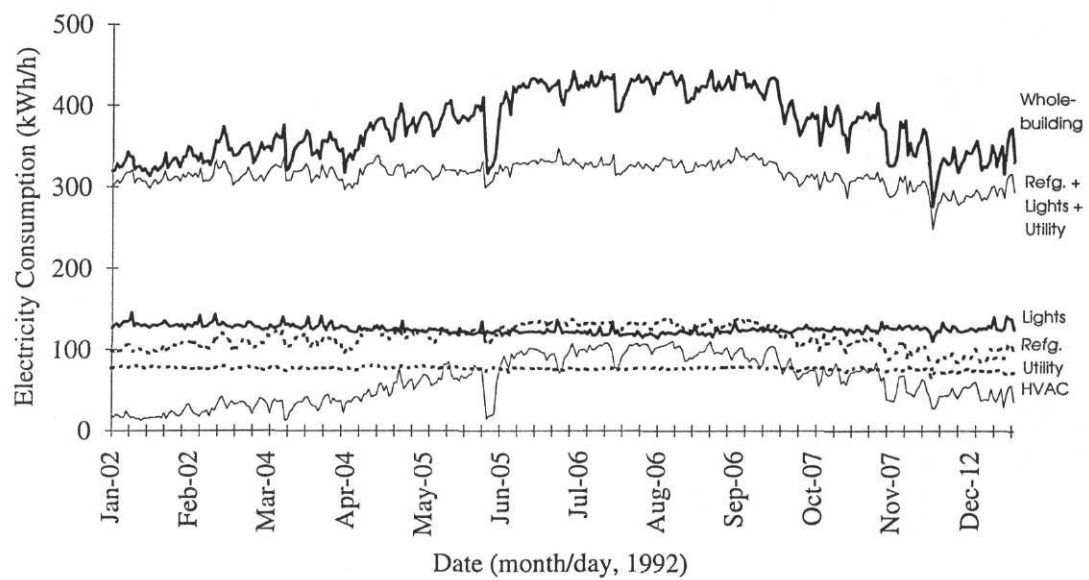
Parameter	Above CP		Below CP	
	MLR	PCA	MLR	PCA
Temperature	50%	-6.2%	13%	1.9%
Specific Humidity	-110%	31%	-550%	240%
Solar	-140%	-13%	-----	-----
Sales	-----	-----	-64%	7.0%
Constant	-10%	-2.6%	3.0%	2.0%

\* The percentages are based on 1989 parameters. For example, for the MLR temperature parameters above the change-point, the difference is calculated as  $(194.02_{1992} - 129.08_{1989}) / (129.08_{1989}) \times 100\%$

For the temperature parameters, the difference between the 1989 and 1992 MLR models was 50%. However, for the corresponding PCA temperature parameters, the difference was only -6.2% -- eight times less for MLR. *In every case, the 1989 and 1992 PCA parameters agree more closely with each other than do the MLR parameters.* That is, PCA seemed better than MLR at re-identifying the same parameters when used to predict data from different time periods.

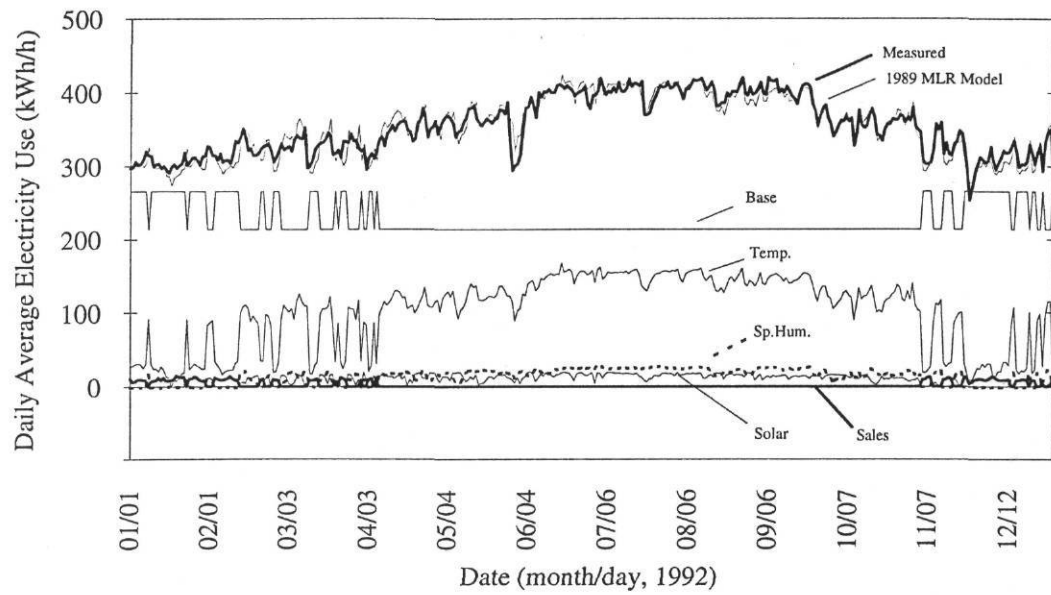
Figure 4.7 shows the four measured end-use loads -- HVAC, utility, refrigeration compressors, and lighting -- plotted individually and added in succession. All four loads added together comprise the whole-building load. It was initially thought that the parameters of the PCA and MLR models had direct physical significance with regards to these loads. For example, we considered whether the temperature parameter of the whole-building model represented the sum of the two temperature-dependent loads -- refrigeration and HVAC. From examining Figures 4.7 to 4.11, it is apparent that the temperature parameter of the models do not predict these loads. Rather, it represents the *sum of the variations* of all temperature-dependent loads with respect to temperature. Thus, a test for physical significance of the parameters must involve gauging only the variations, or patterns, in end-use component loads with respect to a variable. This topic is covered in Section 4.4.

Figures 4.8-4.11 show time-series plots of the predictions of the four models along with the 1992 data. Figure 4.12 is a time series plot of model residuals -- the difference between each model and the observed 1992 data. Perhaps the most

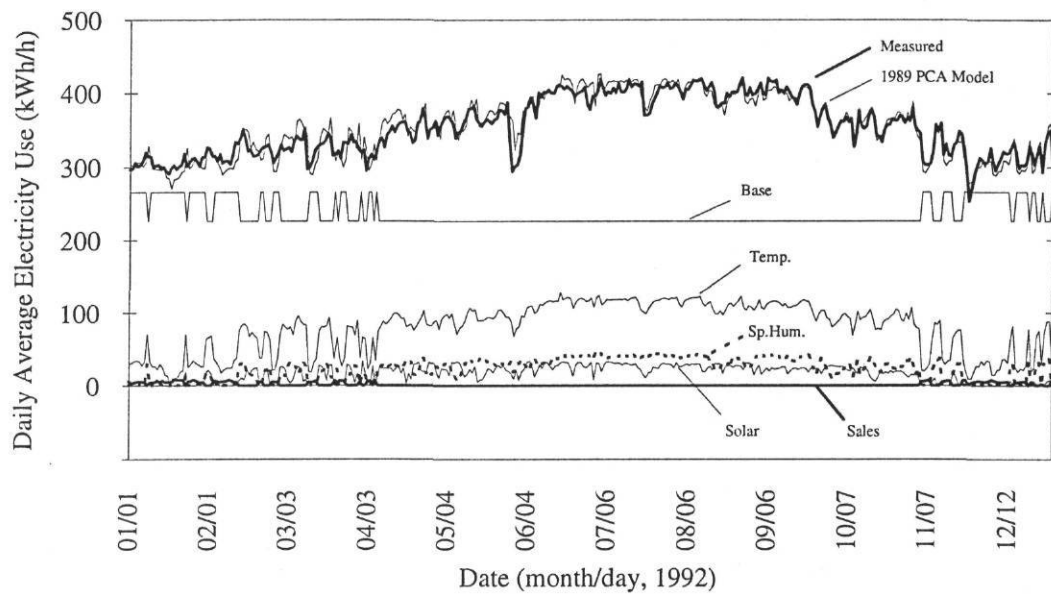


**Figure 4.7**

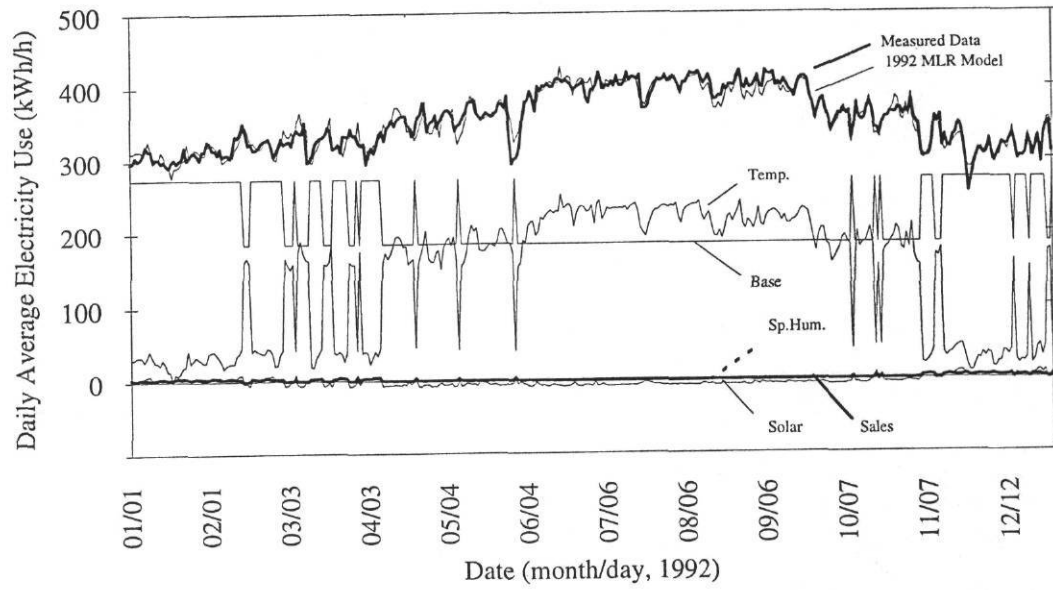
*Time series plot of building electricity loads. This plot shows the four component loads -- HVAC, utility, refrigeration compressors, and lighting -- adjusted to reflect 1989 end-use conditions (without video store and new dairy compressors). The adjusted data are plotted individually and added in succession. All four loads added together comprise the whole-building load.*



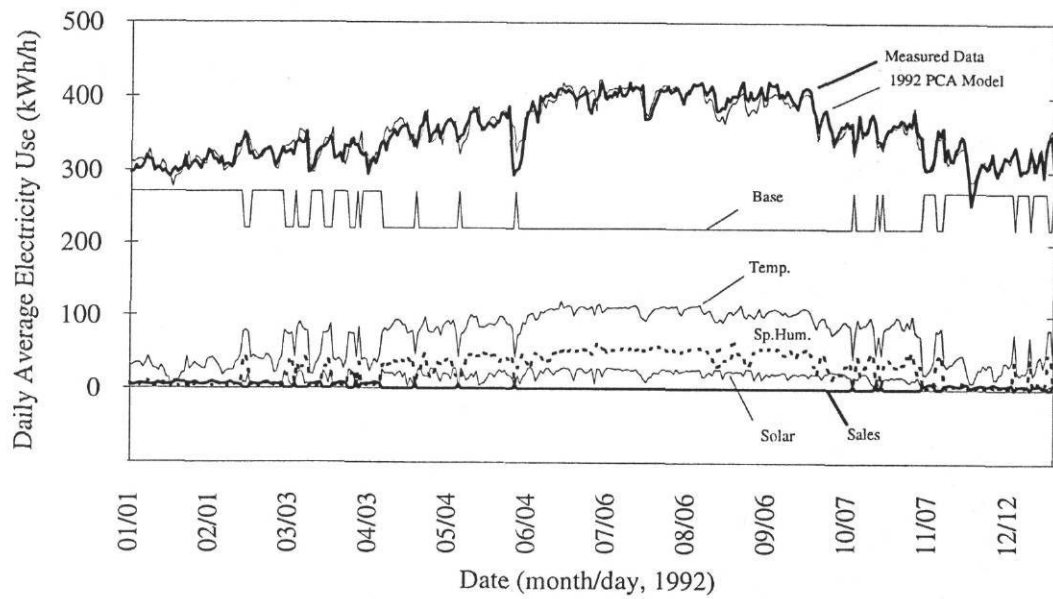
**Figure 4.8** Time Series Plot of 1989 MLR Model Predictions and 1992 Measured Data.



**Figure 4.9** Time Series Plot of 1989 PCA Model Predictions and 1992 Measured Data.

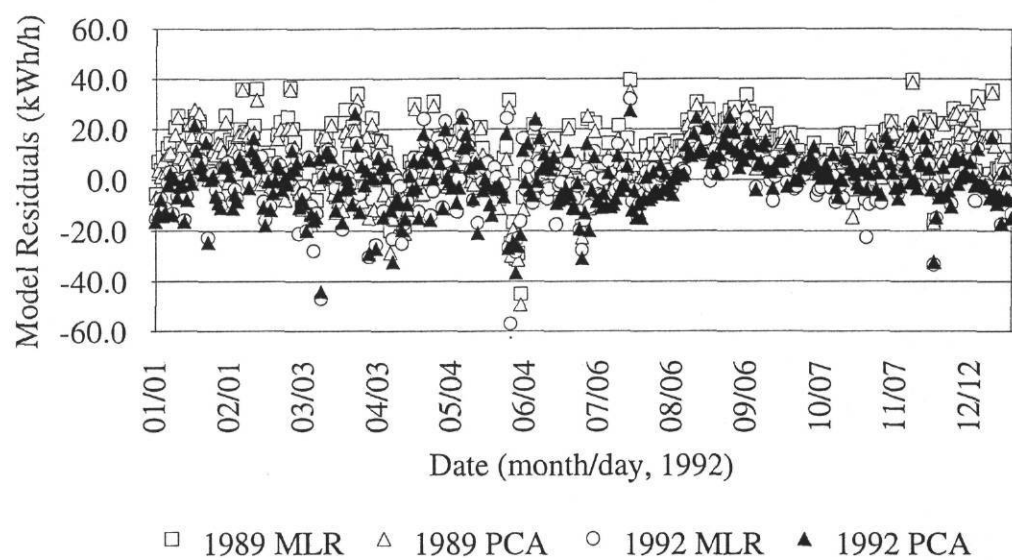


**Figure 4.10** *Time Series Plot of 1992 MLR Model Predictions and 1992 Measured Data.*



**Figure 4.11** *Time Series Plot of 1992 PCA Model Predictions and 1992 Measured Data.*





*Figure 4.12*                      *Time Series Plot of Model Residuals.*

noticeable difference between the MLR and PCA models is the greater effect of temperature in the MLR models. In Figure 4.8 and Figure 4.10, we see that both the 1989 and 1992 MLR models place very little importance on the variables of specific humidity, solar radiation, and sales. In Table 4.16, the percent differences between PCA and MLR model parameters for 1989 and 1992 are shown. Above the change-point, PCA predicts a temperature component which is 23% to 52% less than that of MLR. In 1992, the specific humidity component is 27 times higher for PCA than for MLR. In fact, the specific humidity parameter above the change-point for 1992 is negative for the MLR model, suggesting that an increase in the moisture content of the air decreases the building's energy use. Intuition suggests just the opposite. Increased moisture translates to higher latent loads at the HVAC coils, and higher refrigeration loads. Which set of parameters, then, is more realistic; and, can any physical significance be attached to them? We must use more than intuition to evaluate the performance of the PCA and MLR models. In the next section, the predictions of the models are compared to building loads arrived at through the use of cooling load temperature difference methods.

TABLE 4.16  
Percent Differences in Model Parameters for PCA compared to MLR\*

Parameter	Above CP		Below CP	
	1989	1992	1989	1992
Temperature	-23%	-52%	11%	-0.56%
Specific Humidity	65%	2700%	230%	-3.1%
Solar	72%	450%	-----	-----
Sales	-----	-----	-40%	75%
Constant	5.7%	15%	0.078%	-0.88%

\* based on MLR parameters

## 4.4 PHYSICAL SIGNIFICANCE OF MODEL PARAMETERS

The MLR and PCA models give comparable estimates for whole-building electricity. However, they weight the effects of the variations imposed by the climate variables differently. One way to determine which model gives more realistic estimates is to model the climate-variant portions of the building's energy use by a diversified load calculation method. In using this method we adopt the diversified load estimation procedure outlined by Knebel (1983).

### 4.4.1 Variation Due to Solar Load

The diversified load calculation method using a cooling load temperature difference for solar effects (CLTDS) accounts for solar gains as well as ambient temperature gains for design load estimations. We use only the portion of this procedure which account for solar loads. The calculation of the loads considered the cooling load on the walls, on the roof, and through the glazing of the store. The calculations are covered in detail in Appendix G. For a description of building characteristics, see Chapter 3, Section 3.1.

The diversified load calculations give estimates for the building cooling load as it affects the building envelope. It is a thermal load. To translate this to the load on the building's HVAC equipment, we must consider the system's energy efficiency ratio (EER). EER is a constant which relates the amount of electrical energy which must be put into a cooling system in order to achieve a specified cooling effect. Thus, the EER has units of thermal cooling effect (Btu/hr) per watt input, or Btu/h·W. In Chapter 3, the EER for the College Station HVAC system was determined to be 7.1 Btu/h·W. Since there are 3.413 Btu per watt-hour, this can be converted to a coefficient of performance (COP) of  $2.08 \text{ kW}_{\text{th}}/\text{kW}_e$ .<sup>2</sup> What this means is that it takes only 1 kW of electrical power to produce a thermal cooling load of 2.08 kW.

The diversified load calculations give a total possible variation in cooling load due to solar effects of  $29.1 \text{ kW}_{\text{th}}$ . Dividing this by the COP gives the portion of the load due to solar radiation as only  $14 \text{ kW}_e$ .

The 1992 MLR model analysis predicts that there is no significant variation in the whole-building load due to solar radiation or specific humidity. In fact, the values it gives are *near-zero*, and often negative! However, the 1992 PCA model predicts

---

<sup>2</sup> The subscript "th" is used to designate thermal energy. Likewise, a subscript of "e" will be used to refer to electrical energy.

that the average variable component of the whole-building electricity load due to solar effects is  $19.6 \text{ kW}_e$ .<sup>3</sup> This seems comparable to the  $14 \text{ kW}_e$  variation estimated by the diversified load calculations.

Next, MLR and PCA models were developed for the sub-metered HVAC load. Tables 4.17 and 4.18 show the regression summaries. The models predict an average load due to solar effects of  $-9.1 \text{ kW}_e$  for MLR, and  $15.5 \text{ kW}_e$  for PCA. The fact that the HVAC MLR model predicts a negative load suggests that it is wholly inappropriate for estimating solar effects when other variables are also used in the regression. Intuition tells us that increasing solar radiation should only add to the HVAC load. The fact that the HVAC PCA model predicts a solar effect of  $15.5 \text{ kW}_e$ , allows us to make two points. First, PCA does better at predicting the solar load since the PCA prediction for HVAC is positive and almost equal to the diversified load prediction of  $14 \text{ kW}$ . Second, since the PCA prediction is quite close to the  $19.6 \text{ kW}_e$  predicted by the *whole-building* data, we conclude that the solar load on the whole building appears primarily in the HVAC load.

In both the 1989 and 1992 models, for both the whole-building data and the HVAC data, it can be seen that MLR techniques understate the effects of solar radiation, though this is most apparent from the 1992 models. It is reasonable to assume that, as a result, MLR overstates the variation due to other variables -- such as temperature, but this assumption is tested in the next section.

#### 4.4.2 Variation Due to Temperature

The variation in building electricity load due to temperature can be divided into two components -- that pertaining to the HVAC system, and that pertaining to the refrigeration system. Since the HVAC system keeps the interior space conditions fairly constant, at about  $70^\circ\text{F}$  ( $21^\circ\text{C}$ ) to  $75^\circ\text{F}$  ( $24^\circ\text{C}$ ) and 55% relative humidity, then any effect of outdoor air temperature on the refrigeration system must be realized via the refrigeration system's condenser coils, which are exposed to outdoor ambient air brought into the compressor room.<sup>4</sup>

---

<sup>3</sup> The 1989 MLR and PCA models predict average values of  $12.5$  and  $21.6 \text{ kW}_e$ , respectively.

<sup>4</sup> The hypothesis that the outdoor conditions primarily affect the refrigeration system through its condenser coils can be verified when we consider the bimodal behavior of the refrigeration system below the change-point temperature, as discussed in Chapter 3. It is below this temperature that the condensers are shut off from outdoor air. The fact that the refrigeration data cease to vary significantly when this occurs indicates that the variation in the refrigeration load due to outdoor temperature does indeed come as a result of the condensers' exposure to outdoor air.

The coefficients of temperature in the whole-building PCA and MLR models reflect the whole building's response to temperature, and thus reflect the combined effect of outdoor temperature on both the HVAC system and the refrigeration system. However, a simple energy balance equation, with respect to the temperature difference across the store's walls, roof, and glazing should be useful in determining the effects of outside temperature on the HVAC system alone. We again adopt a procedure outlined by Knebel (1983). Calculations may be found in Appendix G. The sum of the U A values for the building is  $4.31 \text{ kW}_{\text{th}}/\text{°C}$ . This should represent the variation in the HVAC load due to temperature (and temperature only). Accounting for the COP of the HVAC system, which is  $2.08 \text{ kW}_{\text{th}}/\text{kW}_{\text{e}}$ , the temperature coefficient is  $2.07 \text{ kW}_{\text{e}}/\text{°C}$ . This may be compared to the temperature coefficient in the whole-building and HVAC MLR and PCA models.

The 1992 MLR and PCA whole-building models predict the following temperature coefficients:

---

Temperature Coefficients		
Whole-building Model	Below CP	Above CP
PCA :	$60.76 \text{ kWh/day}\cdot\text{°C}$	$92.7 \text{ kWh/day}\cdot\text{°C}$
MLR :	$61.10 \text{ kWh/day}\cdot\text{°C}$	$194.0 \text{ kWh/day}\cdot\text{°C}$

---

On an hourly basis, this is:

---

Temperature Coefficients		
Whole-building Model	Below CP	Above CP
PCA :	$2.53 \text{ kWh/h}\cdot\text{°C}$	$3.86 \text{ kWh/h}\cdot\text{°C}$
MLR :	$2.55 \text{ kWh/h}\cdot\text{°C}$	$8.08 \text{ kWh/h}\cdot\text{°C}$

---

TABLE 4.17  
 Regression Summary: 1992 HVAC Models  
 Above CP of 18.7°C (65°F)

Model Parameters:	Model 1 PCs 1,2,3	Model 2 PCs 1,2	MLR Model -----
Temp (°C)	-----	69.98	167.78
standard error	-----	-----	14.66
SH (kg w/kg a)	-----	57763	-19938
standard error	-----	-----	11983
Solar (W/m <sup>2</sup> )	-----	1.732	-1.0193
standard error	-----	-----	0.4558
Constant	-----	-995.3	-1814.2
standard error	-----	-----	161.2
PC#1 standard error	332.66 12.28	332.66 13.43	----- -----
PC#2 standard error	-15.45 16.91	-15.45 18.50	----- -----
PC#3 standard error	-468.37 69.12	----- -----	----- -----
PCA Constant	1847.7	1847.7	-----
standard error	17.00	18.60	-----
Model R <sup>2</sup>	0.77	0.73	0.77
Model RMSE	258.35	282.66	258.35
% of variation explained	100	98	100

TABLE 4.18  
 Regression Summary: 1992 HVAC Models  
 Below CP of 18.7°C (65°F)

Model Parameters:	Model 1 PCs 1,2,3	Model 2 PCs 1,3	MLR Model
Temp (°C)	-----	28.20	29.22
standard error	-----	-----	8.35
SH (kg w/kg a)	-----	15652	17408
standard error	-----	-----	12550
Sales (\$/day)	-----	0.001704	-0.002380
standard error	-----	-----	0.002812
Constant	-----	254.55	426.01
standard error	-----	-----	156.79
PC#1	111.4	111.4	-----
standard error	21.71	21.81	-----
PC#2	-40.41	-----	-----
standard error	27.61	-----	-----
PC#3	-50.69	-50.69	-----
standard error	42.31	42.50	-----
PCA Constant	784.43	784.43	-----
standard error	27.31	27.43	-----
Model R <sup>2</sup>	0.194	0.181	0.194
Model RMSE	309	310	309
% of variation explained	100	66	100

Clearly, MLR and PCA give very different temperature coefficients for data above the change-point. But these are parameters for the whole-building load, not merely the HVAC component. What we know from the U·A calculations is an HVAC load variation characteristic --  $2.07 \text{ kW}_e/\text{°C}$ . If we consider the HVAC models, we find that both PCA and MLR give very different temperature coefficients for the region above the change-point.<sup>5</sup> The temperature parameters are as follows:

---

Temperature Coefficients			
HVAC		Below CP	Above CP
	PCA :	28.20 kWh/day·°C	69.98 kWh/day·°C
	MLR :	29.22 kWh/day·°C	167.8 kWh/day·°C

---

On an hourly basis, these are:

---

Temperature Coefficients				
HVAC		Below CP	Above CP	Average*
	PCA :	1.18 kWh/h·°C	2.92 kWh/h·°C	2.30
	MLR :	1.22 kWh/h·°C	6.99 kWh/h·°C	4.93

---

\* weighted according to 231 data points above CP, 128 below CP.

The average temperature coefficient (above and below the change-point) for the PCA model is  $2.30 \text{ kWh/h}\cdot\text{°C}$ . This is close to the  $2.07 \text{ kW}/\text{°C}$  from the U·A calculation, differing by 11%. The average MLR parameter of  $4.93 \text{ kWh/h}\cdot\text{°C}$ , which differs from the U·A estimation by 140%. If the U·A calculations are an accurate representation of the effects of changes in outdoor temperature on the HVAC system, then we can conclude that the MLR model grossly overstates the effects of changes in temperature on the store's HVAC load as compared to the prediction of PCA.

What this means is that for a building with a simple HVAC system, some model parameters obtained through PCA have more physical significance than those

---

<sup>5</sup> This characteristic is also seen in the whole-building model. The principal component variables used in each segment of the PCA model are the same as those used in the whole-building model.



obtained through MLR analysis, and that these model parameters correspond to those which are fairly easily measurable (such as building UA and solar load).

For some variables, such as specific humidity, identifying the physical significance of the parameters predicted by PCA (or MLR) may be more difficult and involved since alternative models which would be used to verify the PCA and MLR predictions are likewise complex and involved. For this study, we were not able to verify the significance of the specific humidity or sales parameters provided by either PCA or MLR.

Nevertheless, for this case study, PCA was shown to be of benefit in providing more realistic estimates of the effects of the predictor variables of dry-bulb temperature and solar radiation when these variables are correlated.

#### 4.5 SUMMARY

For the College Station case study, the following conclusions are drawn with regards to principle component analysis.

- 1) The 1992 PCA model worked better than the 1992 MLR model at re-identifying the same model parameters for the 1992 data set as predicted by the 1989 PCA and MLR models. Thus, PCA does better than MLR in terms of parameter re-identification *when used to predict data from a period which was different than that used to construct the model.*
- 2) PCA does slightly better than MLR in terms of  $R^2$  and RMSE criteria *when used to predict data from a period which was not used to construct the model.*
- 3) In both 1989 and 1992 whole-building models, MLR techniques underestimated the effects of solar radiation. For this study, PCA was found to be superior in estimating the effects of the variations in solar radiation on the grocery store whole building electricity use and HVAC system electricity use. The variation in the HVAC load due to solar radiation predicted by the HVAC PCA model was 15.1 kW, which agreed closely with the variation predicted by the diversified load calculation, 14 kW. MLR analysis predicted -5.6 kW.
- 4) In the 1992 models, MLR techniques over estimate the effects of outdoor temperature. For this study, PCA was found to be of greater use than MLR in estimating the effects of variations in temperature on the grocery store whole building electricity use and HVAC system electricity use. The temperature parameter predicted by the HVAC PCA model, 2.34 kWh/h·°C, agreed closely

with the building U·A, 2.07 kWh/h·°C. MLR analysis predicted 4.96 kWh/h·°C.

- 5) One shortcoming of both PCA and MLR analyses is that they determine only one base load. They attempt to account for energy use due to *changes* in variables, but cannot estimate the total effect due to any one variable since the base load cannot be separated into contributions due to each variable.
- 6) For some variables, such as specific humidity, identifying the physical significance of the parameters predicted by PCA (or MLR) may be more difficult and involved, since alternative models which must be used to verify the PCA and MLR predictions are likewise complex and involved. For this study, we did not attempt to verify the significance of the specific humidity or sales parameters provided by either PCA or MLR.

In general, we conclude that for a building with a simple HVAC system, model parameters obtained through PCA have more physical significance than those obtained through MLR analysis<sup>6</sup>, and that these model parameters correspond to those which are fairly easily measurable (such as building UA and solar load).

---

<sup>6</sup> This applies to parameters for which physical significance could be tested.

## CHAPTER V

### END-USE LOAD ESTIMATION

The energy use data analyzed in this thesis were obtained for both the College Station and Bryan grocery stores using intensive sub-metering. In this chapter, simple change-point models are used to determine the quality of information that could have been obtained without the use of sub-metering which is capable of yielding similar daily energy end-use data. First, the various forms of linear sub-meter models which were considered for use are presented and compared. Then, the sub-meter models which were selected are compared to proxy models developed from information which could have been obtained from monthly utility billing data and one-day, walk-through energy use surveys.

Energy end-use information obtained from such models could be useful in assisting store owners in determining if the separate, energy-consuming sub-systems are performing efficiently. Such information can also provide utilities with an inexpensive alternative to end-use load monitoring.

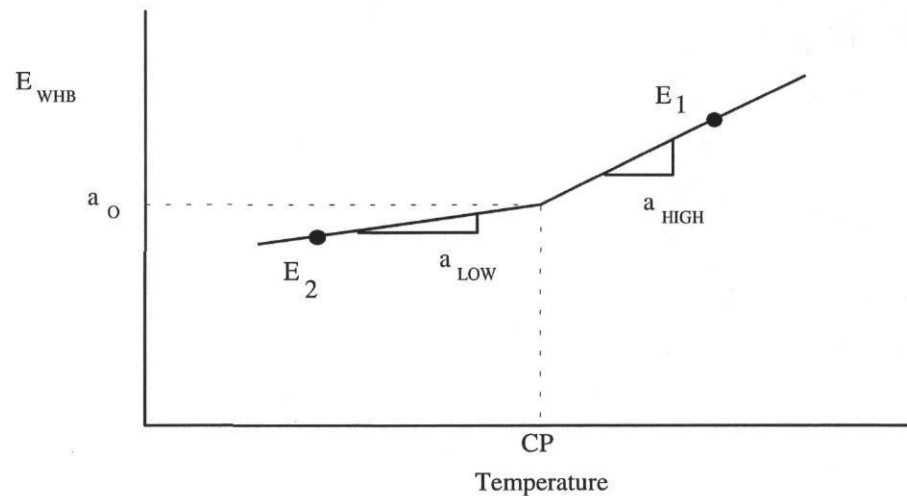
#### 5.1 MODEL OVERVIEW FOR THE COLLEGE STATION STORE

Energy use in grocery stores can be characterized by a mildly temperature-dependent base level below a change-point between 16° and 21°C (60° and 70°F), and a second, more strongly temperature-dependent slope above the change-point. Ruch and Claridge (1992) developed a four-parameter change-point model for the supermarket studied in this thesis. It takes the form:

$$E_{\text{WHB}} = a_0 + a_{\text{LOW}}(T - \text{CP})^- + a_{\text{HIGH}}(T - \text{CP})^+ \quad (5.1a)$$

where  $T$  is the outdoor ambient temperature,  $\text{CP}$  is the change-point temperature,  $a_0$  is a base-level consumption,  $a_{\text{LOW}}$  is the slope below the change-point temperature, and  $a_{\text{HIGH}}$  is the slope above the change-point temperature. The superscripts,  $+$  and  $-$ , designate that the terms to which they apply are only present in the equation when they are positive or negative, respectively (see Figure 5.1). For example, point  $E_1$ , which occurs above the change-point, would be determined by,

$$E_1 = a_0 + a_{\text{HIGH}}(T - \text{CP})^+ \quad (5.1b)$$



**Figure 5.1** Four-parameter change-point model.

Likewise, point  $E_2$ , which occurs below the change-point, would be determined by,

$$E_2 = a_0 + a_{\text{LOW}}(T - \text{CP})^- \quad (5.1c)$$

Using the change-point selection methods outlined by Ruch and Claridge, a four-parameter change-point model was developed for the whole-building electricity use as well as for the HVAC and refrigeration systems' energy use at the College Station grocery store. Constant linear models, which are simply mean of the data being modeled, were chosen for the lighting and utility loads. All models were chosen based on comparisons of mean (constant linear model), simple linear (non-zero slope), and three- and four-parameter change-point models. The models with the best fit and most physical significance were chosen to represent the various sub-metered loads. They are summarized according to  $R^2$  and coefficient of variation as follows (the models which were chosen are underlined):

	Data		Simple linear		3-P CP		4-P CP	
	Mean	CV*	R <sup>2</sup>	CV	R <sup>2</sup>	CV	R <sup>2</sup>	CV
<b>Refrigeration</b>								
<b>Compressors:</b>	114.2	12%	83%	5%	85%	5%	86%	5%
<b>Lighting:</b>	124.7	4	27	4	33	3	33	3
<b>Combined-store</b>								
<b>HVAC:</b>	84.0	46	83	19	90	14	91	14
<b>Miscellaneous</b>								
<b>Utility:</b>	76.4	3	6	3	7	3	10	3
<b>Whole-building:</b>	399.4	12	89	4	94	3	95	3

\* CV = coefficient of variation (root mean squared error ÷ data mean)

In addition, a sinusoidal lighting model, discussed later in this chapter, was considered. The sinusoidal lighting model had an R<sup>2</sup> of 42% and a CV of 3%.

The parameters for the models chosen for the component and whole-building loads are as follows:

Load	a <sub>O</sub> (kWh/h)	a <sub>LOW</sub> (kWh/h-°C)	a <sub>HIGH</sub> (kWh/h-°C)	Change-point (°C)
E <sub>COMP</sub>	104.9	1.1421	2.4006	17.4
E <sub>LIGHTS</sub>	124.7			
E <sub>HVAC</sub>	49.65	1.3772	7.8043	17.4
E <sub>UTIL</sub>	76.41			
E <sub>WHB</sub>	363.5	3.0144	9.7477	18.0

The choice of which model to use for subsequent analyses was made by selecting the model with the best R<sup>2</sup> and CV values, as well as intuitive knowledge of the nature of some of the component loads in the store. For example, for loads which had a visible and physically meaningful change-point, such as those known to have on/off thermostatic controls, change-point models were chosen when appropriate. For loads which were known to be independent of temperature, such as lighting and food-

preparation equipment, constant data mean models were chosen even when change-point models may have had the statistical upper hand. Model selection is described below.

**Whole-building and HVAC Loads.** The selection of a change-point model for the HVAC and whole-building loads seemed appropriate since the data had a visible change-point. Furthermore, we knew that the HVAC system has a space condition set-point of about 21° to 24°C (70° to 75°F) and a humidity control that was active in the 16° to 21°C (60° to 70°F) range. The four-parameter models had a slight advantage over the three-parameter models for the combined-store HVAC and whole-building data.  $R^2$  was highest and CV lowest for the four-parameter models. The change-point of the whole building model was found to be 18.0°C (63.8°F), and the change-point for the HVAC system model was found to be 17.4°C (63.3°F).

**Compressor Load.** The refrigeration compressor load also seemed to display an ambient temperature change-point characteristic. There are two physical explanations for the change-point. First, the refrigeration condenser coils are housed in the compressor room through which outdoor ambient air is drawn by four exhaust fans. These fans shut off when the room temperature falls below 15.9°C (60°F). This lessens the effect of outdoor temperature on the condenser coils, resulting in a different slope below 15.9°C. Second, when the outdoor temperature falls below about 17.4°C (63.3°F), the HVAC system uses reclaimed heat from the refrigeration condenser lines. The air to which the reclaim condenser coils are exposed is at a different temperature than the outdoor air, and thus the slope of the refrigeration compressor energy use curve changes. *It is interesting to note that the change-point temperature identified with the four-parameter model is 17.4°C (63.3°F) -- which is the same as the change-point for the HVAC system.*

Since a change-point model was appropriate for the refrigeration system, the three- and four-parameter models were compared.  $R^2$  is 1 percentage point higher for the four-parameter model than for the three-parameter model, and the CV (before rounding) was 0.1% lower. Thus, the four-parameter model was chosen.

**Lighting Load.** There are no components to the store's lighting load which have a temperature change-point characteristic. In fact, we had no reason *not* to choose a flat, linear model. Upon initial inspection of the lighting data, there appeared to be a temperature dependency. However, this was not truly a temperature effect, but rather a seasonal effect that is the result of the change in the length of daylight throughout the

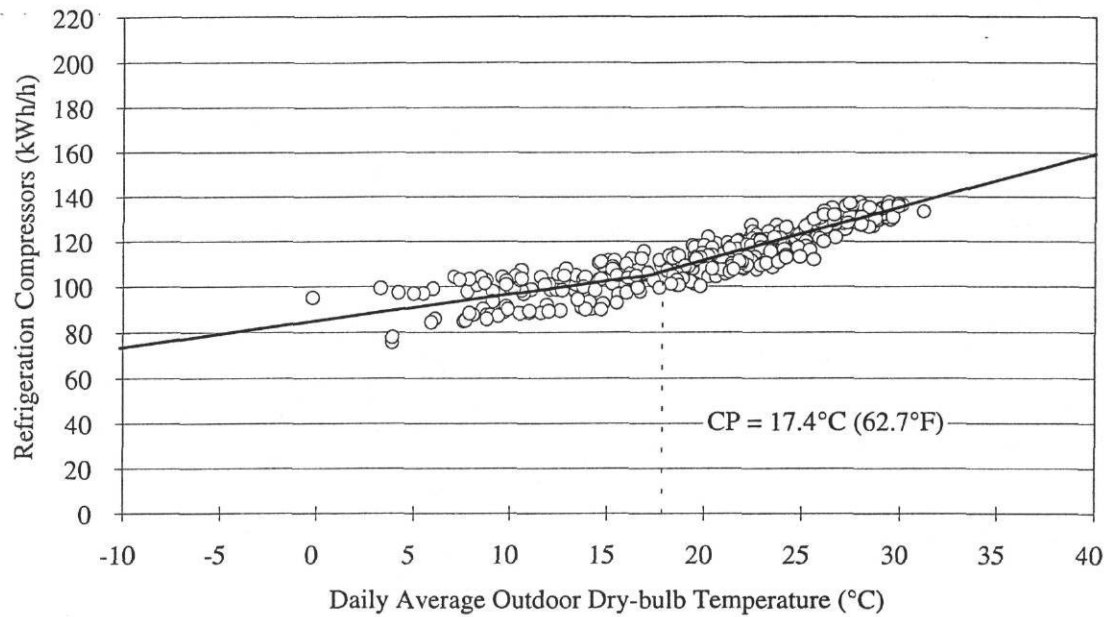
year (which is indirectly related to temperature). If the lighting energy use is plotted with respect to time, it is apparent that the load is sinusoidal. Such a sinusoidal load appears as a slightly temperature-dependent curve when plotted against temperature. An alternative model to a flat linear analysis was the use of a sinusoidal time function.<sup>1</sup> But, while the sinusoidal model actually gave a better fit based on the comparison of CV values, it was developed visually and therefore was considered undesirable since its identification was not repeatable. Thus, a flat linear model, which predicts the average of the data, was chosen for analysis of the lighting load.

**Miscellaneous Utility Load.** Like the lighting load, none of the end-use loads identified on the utility circuit were significantly temperature-dependent. Thus a flat linear model was deemed appropriate. The CV values are nearly the same for the flat mean, simple linear, and three - and four-parameter models, which helped to justify the selection of the constant mean model. For the sake of simplicity and physical meaningfulness, the flat mean model was chosen for the utility load.

Figure 5.2 shows the refrigeration compressor model and data. Below the change-point temperature, the slope is less pronounced. It is below this point that a heat reclamation system is used to recover the waste heat from the refrigeration system in order to provide space heating in the HVAC system. The heat reclamation coils take the place of the refrigeration condenser coils when heat reclaim is in use. Because of this, outdoor temperature has less of an effect on refrigeration system energy use when the system is not exposed to outdoor conditions via the condenser coils. The reader may notice two modes of energy use below the change-point. In this bimodality, the higher mode represents occasions when the compressor room temperature is kept at 15.9°C (60°F) by the operation of the exhaust fans but when heat reclaim is not in use. The lower mode represents days when significant heat reclaim is in use and there is reheating for dehumidification purposes. This occurs during the heating season, when outdoor air is below the change-point. The exhaust fans may shut the compressor room air supply off, but the chilled air being blown across the heat reclaim coils is cooler than the compressor room air, and thus allows the refrigeration system to reject its waste heat more efficiently -- resulting in a lower load on the compressors. This effect is discussed further in Chapter 3, Section 3.4.3.

---

<sup>1</sup> Discussed later in this chapter.



**Figure 5.2**

*Refrigeration compressor data and temperature change-point model for the period 01/01/92 to 01/01/93 for College Station. The lower of the two modes of energy use below the change-point corresponds to times when heat reclaim and reheat are in use.*



Figure 5.3 is a plot of the lighting data and model. Because the parking lot light timer is adjusted monthly to account for the seasonal variation in the length of the day, the warmer, summer season has a slightly smaller load than the cooler, winter season. This causes the plot in Figure 5.3 to appear as if the lighting load is temperature-dependent when, in fact, the relationship is a seasonal dependency which is caused by the operation of the parking lot lights. Because of this, the constant lighting model slightly over-predicts energy use above about 20°C (67.4°F), and under-predicts it for temperatures below 20°C. Nevertheless, the coefficient of variation for the constant model is only 4.1%, which implies that the root-mean-squared-error (RMSE) of the model is 4.1% of the mean value of the data. Thus, if amp measurements of the lighting electrical panel were taken in the morning, afternoon, and at night, a daily average load could be calculated from known operating schedules. This average would differ from the yearly average by about 4% or less.

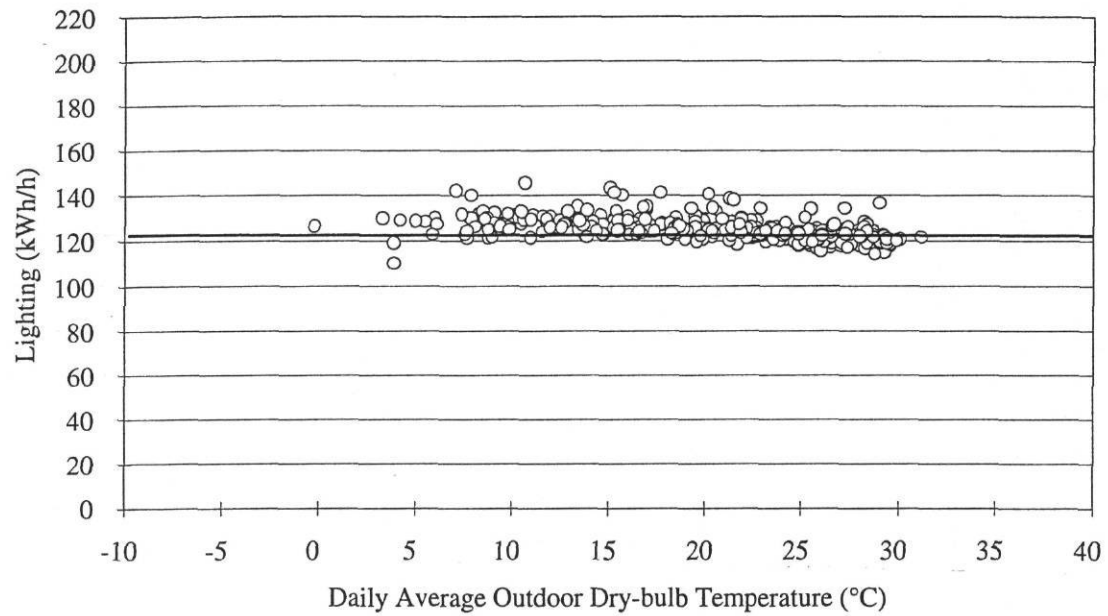
Figure 5.4 shows the combined-store HVAC model and data. In it may be seen the bimodality of the energy consumption resulting from the use of reheating to provide dehumidification. The higher mode represents days when significant reheating was used. During the reheat stage, one compressor is turned on to remove moisture from the air.<sup>2</sup> This air is then reheated by the heat reclaim system. The higher mode in the HVAC data corresponds to the lower mode in the refrigeration compressor data. This interrelationship is discussed further in Chapter 3, Section 3.4.3.

The miscellaneous utility data and model are shown in Figure 5.5. This energy use is quite constant. The root mean square error for the model is only 2.7% of the yearly of the data. This suggests that if the electric panels for the utility load were measured with hand-held clamp meters at any time during the day, the average reading for the day could be used to predict utility energy use for the entire year. to an accuracy of about 97%.

From Figure 5.6 and Figure 5.7, it can be seen how the sub-metered load models can be added together to obtain a whole-building load. Figure 5.6 shows the whole-building model and data. The change-point of 18.0°C (63.8°F) is quite noticeable. It is slightly higher than the 17.4°C (62.7°F) change-point associated with the refrigeration and HVAC systems because the whole-building data include the

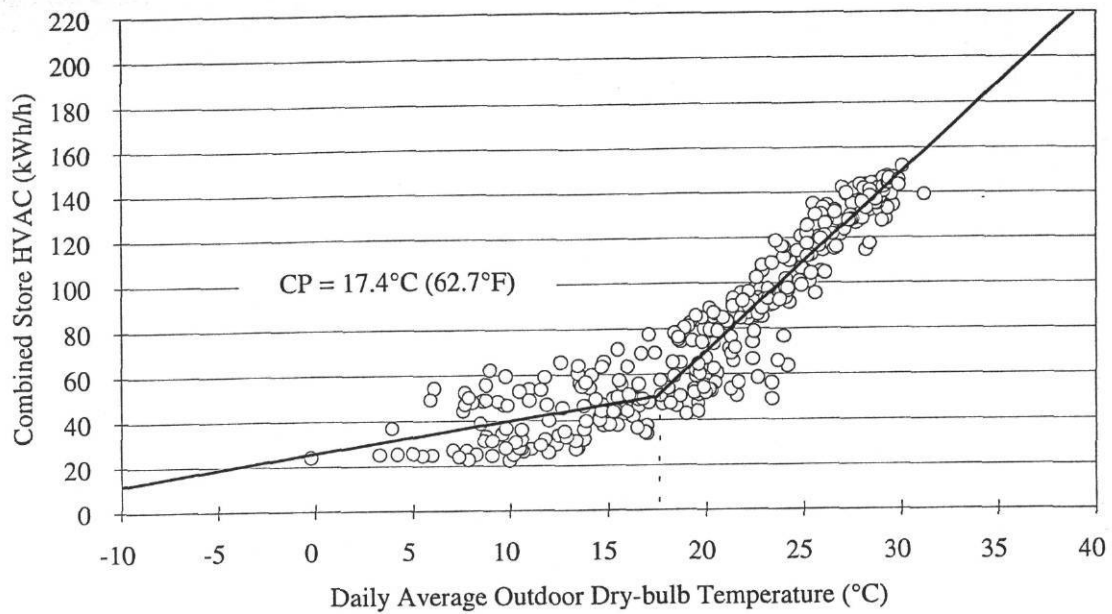
---

<sup>2</sup> One compressor comprises a load of roughly 20 to 30 kW

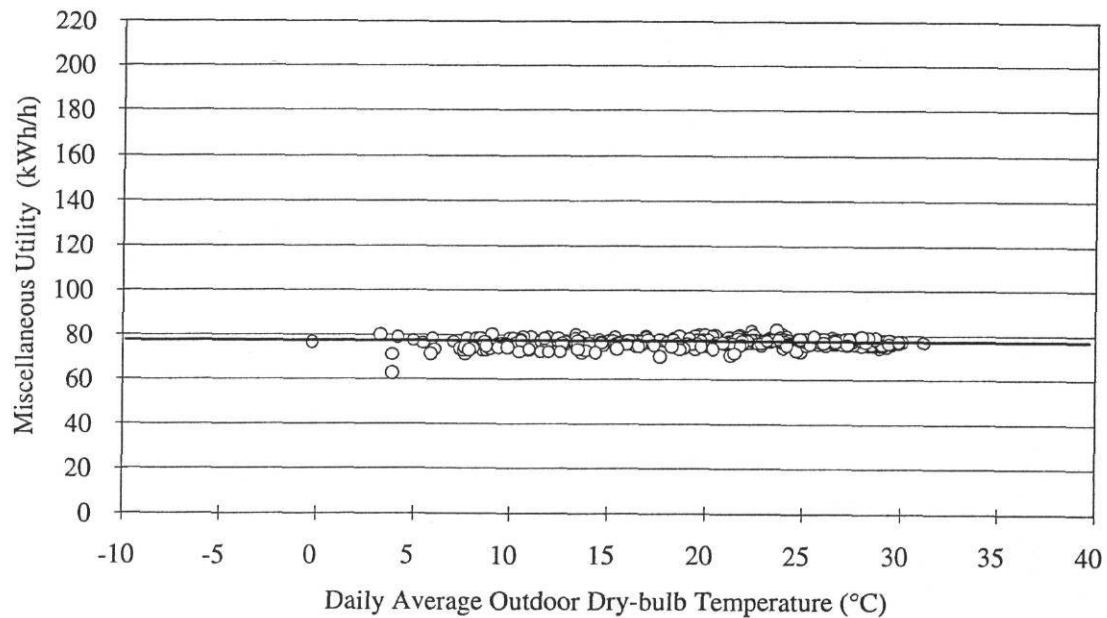


**Figure 5.3**

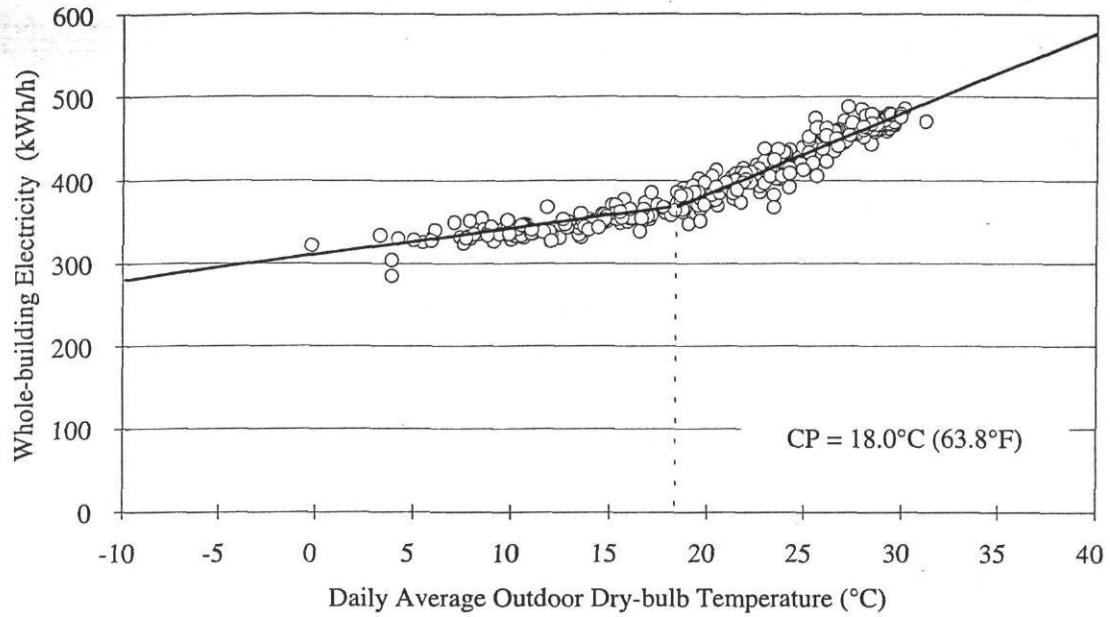
*Lighting data and constant linear model for the period 01/01/92 to 01/01/93 for College Station. The slope in the data is due to the seasonal change in outdoor lighting load requirements.*



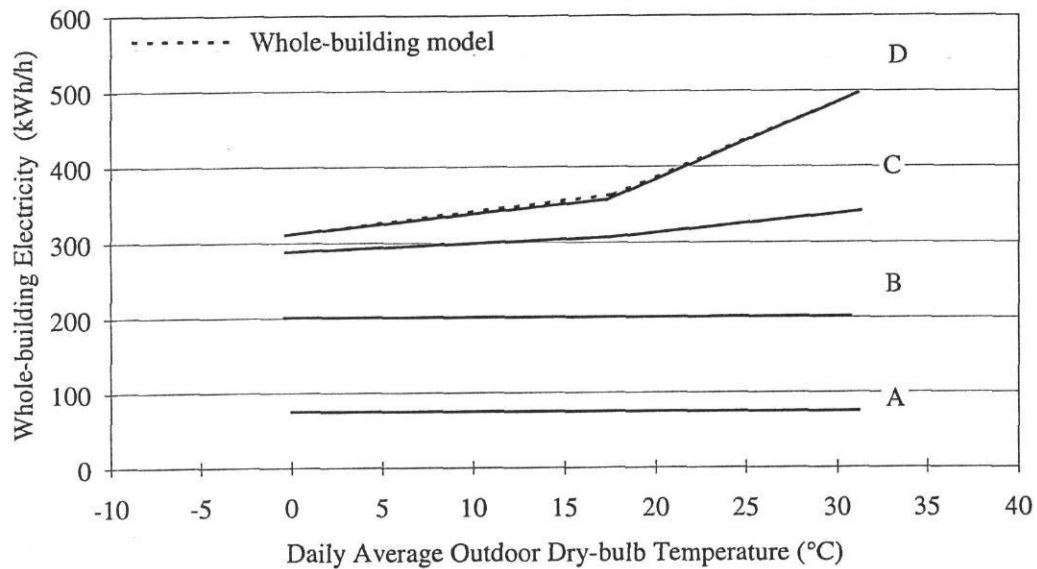
**Figure 5.4** Combined store HVAC data and temperature change-point model for the period 01/01/92 to 01/01/93 for College Station.



**Figure 5.5** Utility data and constant linear model for the period 01/01/92 to 01/01/93 for College Station.



**Figure 5.6** Whole-building electricity data and temperature change-point model for the period 01/01/92 to 01/01/93 for College Station.



**Figure 5.7** Addition of sub-metered electricity loads for College Station. Curve A represents the utility load model. Curve B is the utility model plus the lighting model. Curve C is the sum of the utility, lighting, and refrigeration models. Curve D is the sum of the utility, lighting, refrigeration, and HVAC models.

lighting and utility loads which cause the regression procedure to weigh the data differently, thus pulling the change-point up to 18.0°C. This results in a different change-point temperature for the whole building. The bimodality seen in the HVAC and refrigeration compressor data is not as easily seen in the whole-building data. This is because of a trade-off effect -- when the HVAC system uses more energy in the reheat/heat reclaim stage, the refrigeration system uses less, and vice-versa. Thus, the bimodality is blended into one mode of daily whole-building energy use.

In Figure 5.7, curve *A* represents only the miscellaneous utility load. Curve *B* is the sum of the utility load model and the lighting model. Curve *C* is the sum of the utility, lighting, and refrigeration compressor models; and curve *D* is the sum of the utility, lighting, refrigeration compressor, and HVAC models. Curve *D* coincides with the whole-building model (i.e., the dashed line).

The models developed above were applied to degree-hour bins to predict energy use for a period of time using binned temperature data. This is the subject of the next section.

## **5.2 BIN MODEL APPLICATION FOR THE COLLEGE STATION STORE**

With the models identified, binned weather data were applied to the models to determine the energy load for any arbitrary period of time -- in this case, a full year.<sup>3</sup> Since bin data were not available for the College Station area, a program was developed to take hourly weather data and group them into bins.<sup>4</sup>

### **5.2.1 Binned Temperature Models**

The models identified in Section 5.1 predict kilowatts per degree centigrade. When they are multiplied by binned degree-hours, they predict energy use in kilowatt-hours. The bin models were applied to the full year of 1992 binned temperature data, and compared to the measured data for the same year. Results for the component load and whole-building models are shown in Tables 5.1 to 5.5. These tables show the bin hours used, the actual electrical consumption for each bin, and the model predictions

---

<sup>3</sup> In this analysis, binned temperature data from 01/01/92 to 01/01/93 were used. Once the models have been established, binned temperature data from any period and geographic location can be used.

<sup>4</sup> The procedure is included in Appendix B.

TABLE 5.1  
Bin Simulation for 4-P Refrigeration Model for College Station Store

Temperature (°C)			Hours	kWh (data)	Refr.		Diff
low	high	avg			kW	kWh	
-10	-5	-7.5	0	0	76	0	0.00%
-5	0	-2.5	19	1605	82	1562	-2.69%
0	5	2.5	192	16834	88	16877	0.26%
5	10	7.5	762	68341	94	71332	4.38%
10	15	12.5	1137	106084	99	112929	6.45%
15	20	17.5	1651	174219	105	173650	-0.33%
20	25	22.5	2179	256499	117	255338	-0.45%
25	30	27.5	1708	219846	129	220647	0.36%
30	35	32.5	835	116116	141	117891	1.53%
35	40	37.5	8	1150	153	1226	6.56%
Total:				960693	kWh/yr	971452	1.12%

TABLE 5.2  
Bin Simulation for Constant Linear Lighting Model for College Station Store

Temperature (°C)			Hours	kWh (data)	Lights		Diff
low	high	avg			kW	kWh	
-10	-5	-7.5	0	0	124.7	0	0.00%
-5	0	-2.5	19	1791	124.7	2369	32.32%
0	5	2.5	192	20725	124.7	23942	15.52%
5	10	7.5	762	89671	124.7	95021	5.97%
10	15	12.5	1137	132959	124.7	141784	6.64%
15	20	17.5	1651	198963	124.7	205880	3.48%
20	25	22.5	2179	266779	124.7	271721	1.85%
25	30	27.5	1708	221175	124.7	212988	-3.70%
30	35	32.5	835	115270	124.7	104125	-9.67%
35	40	37.5	8	1124	124.7	998	-11.28%
Total:				1048457	kWh/yr	1058828	0.99%

TABLE 5.3  
Bin Simulation for 4-P HVAC Model for College Station Store

Temperature (°C)			Hours	kWh (data)	HVAC		Diff
low	high	avg			kW	kWh	
-10	-5	-7.5	0	0	15	0	0.00%
-5	0	-2.5	19	473	22	423	-10.49%
0	5	2.5	192	5533	29	5597	1.14%
5	10	7.5	762	26366	36	27459	4.15%
10	15	12.5	1137	44613	43	48803	9.39%
15	20	17.5	1651	98402	51	83465	-15.18%
20	25	22.5	2179	201504	90	195185	-3.14%
25	30	27.5	1708	210747	129	219644	4.22%
30	35	32.5	835	127973	168	139961	9.37%
35	40	37.5	8	1318	207	1653	25.46%
Total:				716929	kWh/yr	722189	0.73%

TABLE 5.4  
Bin Simulation for Constant Linear Utility Model for College Station Store

Temperature (°C)			Hours	kWh (data)	Utility		Diff
low	high	avg			kW	kWh	
-10	-5	-7.5	0	0	76.4	0	0.00%
-5	0	-2.5	19	1376	76.4	1452	5.51%
0	5	2.5	192	13459	76.4	14671	9.00%
5	10	7.5	762	54690	76.4	58224	6.46%
10	15	12.5	1137	80707	76.4	86878	7.65%
15	20	17.5	1651	123855	76.4	126153	1.86%
20	25	22.5	2179	165969	76.4	166497	0.32%
25	30	27.5	1708	133117	76.4	130508	-1.96%
30	35	32.5	835	67493	76.4	63802	-5.47%
35	40	37.5	8	647	76.4	611	-5.52%
Total:				641312	kWh/yr	648797.3	1.17%

TABLE 5.5  
Summary of Bin Simulation for Component Models for College Station Store

Temperature (°C)			Hours	Total Data kWh	Model Lighting kWh	Model Utility kWh	Model Refr. kWh	Model HVAC kWh	Total kWh	Diff (%)
low	high	avg								
-10	-5	-7.5	0	0	0	0	0	0	0	0.00%
-5	0	-2.5	19	5244	2369	1452	1562	423	5806	10.72%
0	5	2.5	192	56551	23942	14671	16877	5597	61087	8.02%
5	10	7.5	762	239067	95021	58224	71332	27459	252038	5.43%
10	15	12.5	1137	364361	141784	86878	112929	48803	390394	7.14%
15	20	17.5	1651	595440	205880	126153	173650	83465	589147	-1.06%
20	25	22.5	2179	890751	271721	166497	255338	195185	888742	-0.23%
25	30	27.5	1708	784887	212988	130508	220647	219644	783786	-0.14%
30	35	32.5	835	426851	104125	63802	117891	139961	425780	-0.25%
35	40	37.5	8	4239	998	611	1226	1653	4488	5.86%
Data Sum:				3367392						
Incomplete Data*:				99513						
Model Sum:					1058828	648787	971452	722189	3401266	1.01%
Bill Sum:				3557200						

\* Represent consumption data for which corresponding temperature data were not available.

of consumption for each bin. Tables 5.1 to 5.4 also show the residual difference (as a percent) between the bin predictions and the data. While the differences may be as high as 33% for any individual bin, the annual totals of data and bin predictions differ by no more than 1.2%. In Table 5.5, the component load bin predictions are summarized. Three whole-building annual energy consumptions are compared. These are the measured whole-building electricity, the sum of the predictions of the component bin models, and the annual electricity consumption taken from twelve months of 1992 utility bill data. There is a 3% difference between the sub-metered consumption, 3,466,905 kWh/yr, and the utility bill consumption, 3,557,200 kWh/yr (bill data and sub-meter whole-building data differ by about 3%). The bin model prediction, 3,401,266 kWh/yr, falls below the other two values, and differs by no more than 4% from either. Also listed in the table is the total for data which could not be



processed by the binning routine. These were energy consumption data for which corresponding hourly temperature data were not available. Their sum is 99,513 kWh. This is a relatively small amount, and does not explain the 3 to 4% difference between the sub-metered model and the utility bill data.<sup>5</sup>

Figure 5.8 and Figure 5.9 show time-series and bin model predictions for the refrigeration compressors. The bin model predicts the refrigeration load fairly consistently over the entire range of temperatures (-10°C to 40°C). The bin axis labels represent the midpoints of each 5-degree bin. As is the case for all of the subsequent bin plots, the consumption data are skewed towards the higher temperatures in the range. This reflects the behavior of the temperature variable rather than that of the energy consumption. The greatest percent difference for a refrigeration consumption bin is 6.6%.<sup>6</sup> However, if the sum of the binned predictions is compared to the annual sum of the sub-metered refrigeration data, the difference is only 1.1%.

Figure 5.10 shows a time-series plot of the daily average of the lighting data. The daily average of the lighting data depends only on the length of the day. Specifically, the scheduling of the outdoor lights is adjusted monthly as the daylight hours vary. This has the effect of producing a sinusoidal pattern in the data rather than a constant energy use. The sinusoidal pattern is described in greater detail in Section 5.3.1. Figure 5.11 shows the binned hourly lighting load and predictions. Predictions and data within each bin differ as much as 32%. However, this occurs in the extreme bins which contain less than 0.2% of the energy consumption. Below 25°C, predictions are consistently greater than the data. Likewise, above 25°C, predictions are consistently less than the data. This is due to the fact that we are using a constant model to predict consumptions which varies slightly with respect to temperature.<sup>7</sup>

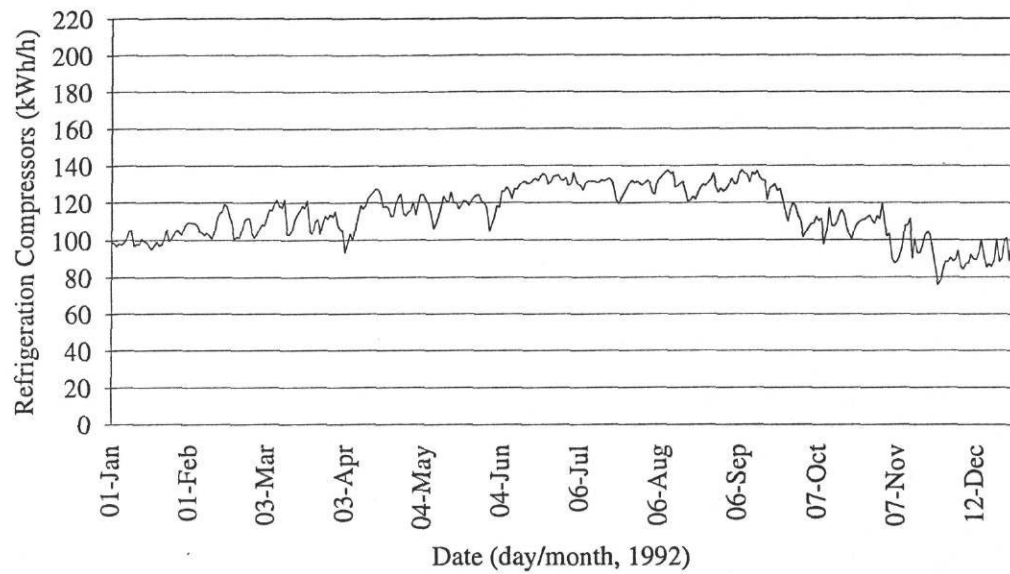
Figure 5.12 and Figure 5.13 are plots of time-series energy use and binned hourly electricity use for the combined-store HVAC system. Differences in binned

---

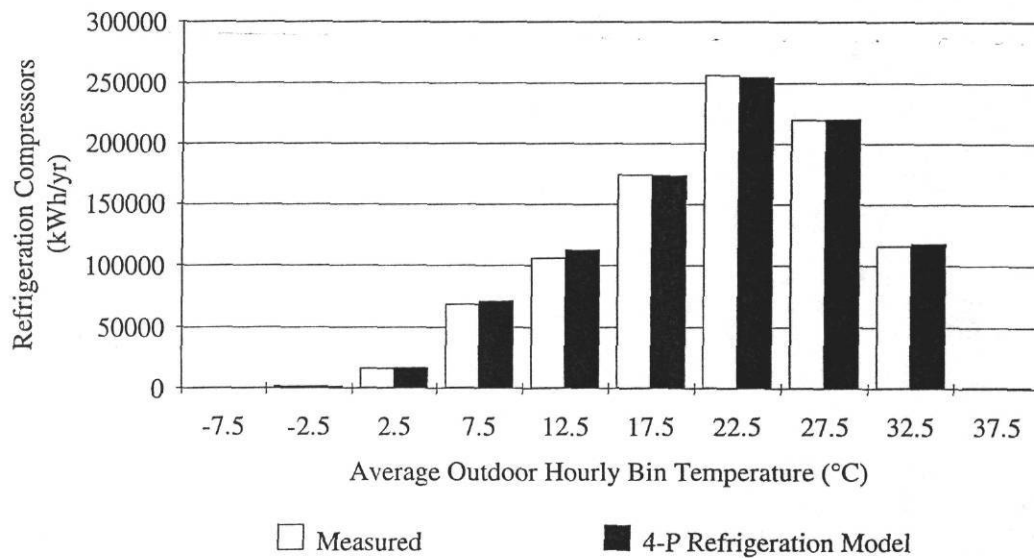
<sup>5</sup> We speculate that the difference in the utility bill and the sub-metered data may be due to inaccuracies in the current and potential transducers used to monitor the sub-metered energy use. In addition, there may be inaccuracies in the current transducers used by the electric utility for billing purposes.

<sup>6</sup> Based on sub-metered data for each respective bin.

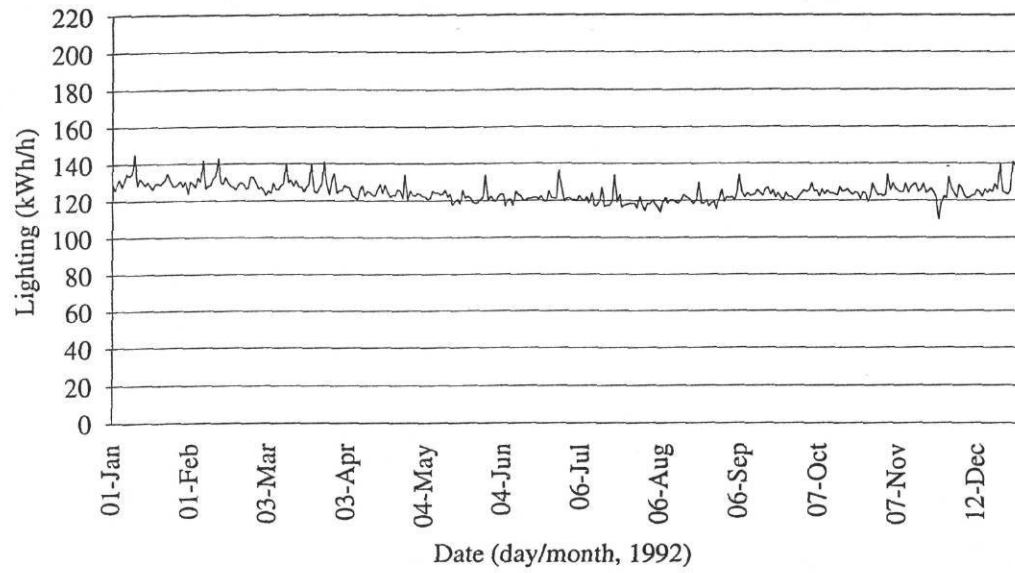
<sup>7</sup> However, by no means do we wish to imply by this that the lighting data are temperature-dependent. Recall the seasonal dependency in the parking lot lights.



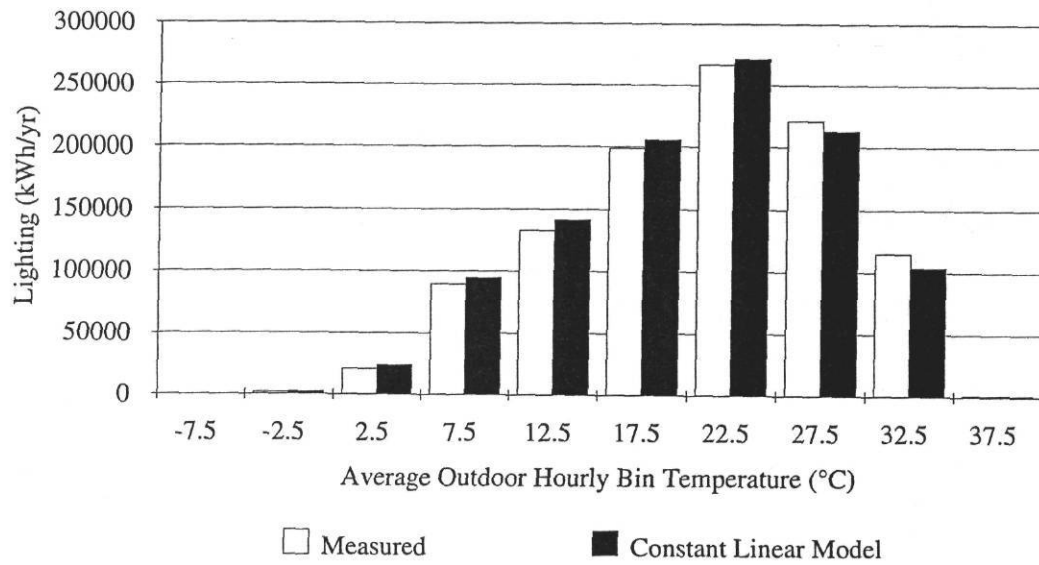
**Figure 5.8** *Time series plot of daily average refrigeration compressor load for 1992 for College Station.*



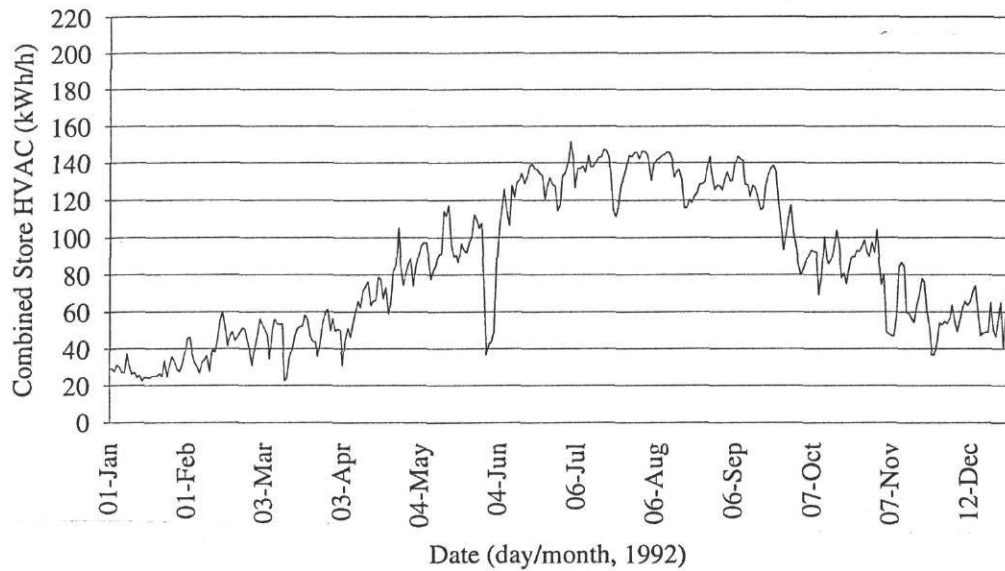
**Figure 5.9** *Binned hourly electricity consumption for four-parameter refrigeration compressor model from 01/01/92 to 01/01/93 for College Station.*



**Figure 5.10** Time series plot of daily average lighting load for 1992 for College Station.

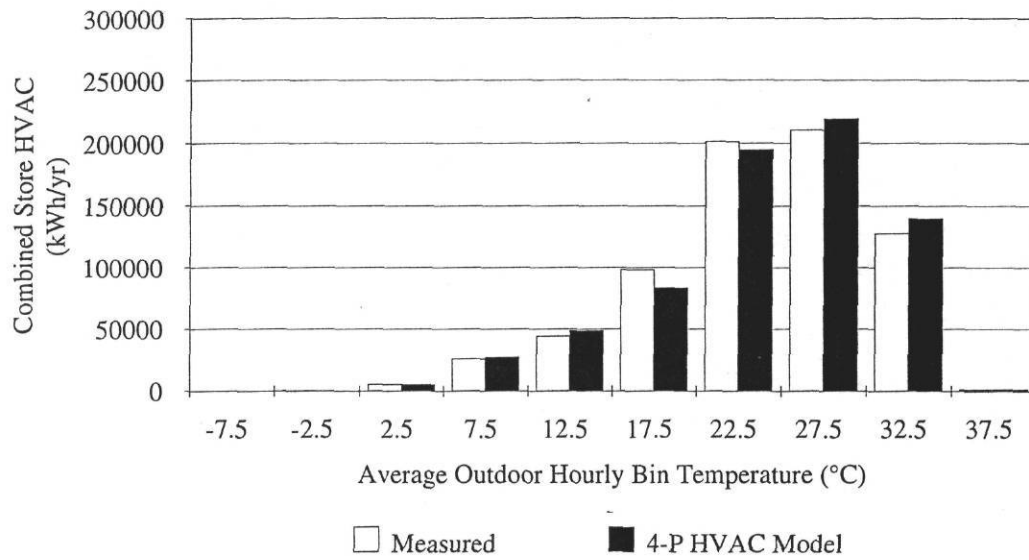


**Figure 5.11** Binned hourly electricity consumption for constant linear lighting model from 01/01/92 to 01/01/93 for College Station.



**Figure 5.12**

*Time series plot of daily average, combined-store HVAC load for 1992 for College Station. The highly visible drop in energy use near the beginning of June was caused by a shut-down which was required for maintenance of an electrical line within the store.*



**Figure 5.13**

*Binned hourly electricity consumption for four-parameter combined-store HVAC model for 01/01/92 to 01/01/93 for College Station.*

energy use and predicted energy use are as high as 25% for a particular bin. However, the actual and predicted annual energy consumptions differ only by 0.73%. As in the case of the refrigeration system, there is no consistent trend in the differences between the actual and predicted binned energy use.

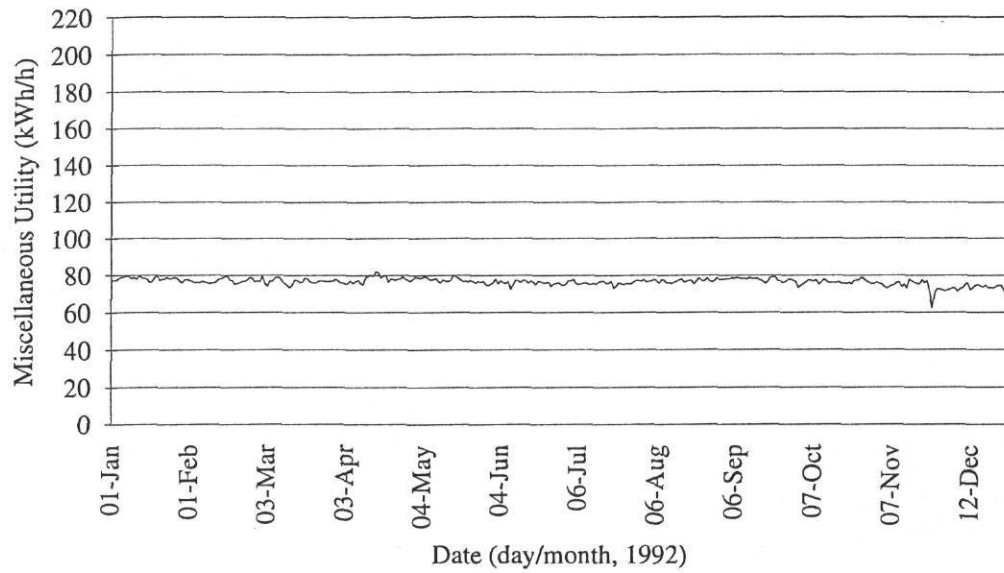
Figure 5.14 and Figure 5.15 show the miscellaneous utility load as a time-series and binned data plot. Because the utility data are so nearly constant, a drop in food-preparation equipment energy use, which occurs over the Thanksgiving holiday (11/27/92), can be easily seen. Similar, yet more pronounced, drops in store-wide energy use over the Christmas holidays (12/24 to 12/26) were removed from the data set. The binned energy predictions differ from the binned data by no more than 9%, and tend to underestimate the energy use at higher temperatures, while overestimating it at lower temperatures.

Finally, Figure 5.16 and Figure 5.17 show the time-series plot and binned data and model plot for the whole-building. Individual bin predictions differ by no more than 11% from their corresponding binned data, and tend to underestimate consumption at higher temperatures. On the whole, the annual sum of the predictions differs by only 1% from the annual whole-building energy use data.

### 5.2.2 Alternative Lighting Model

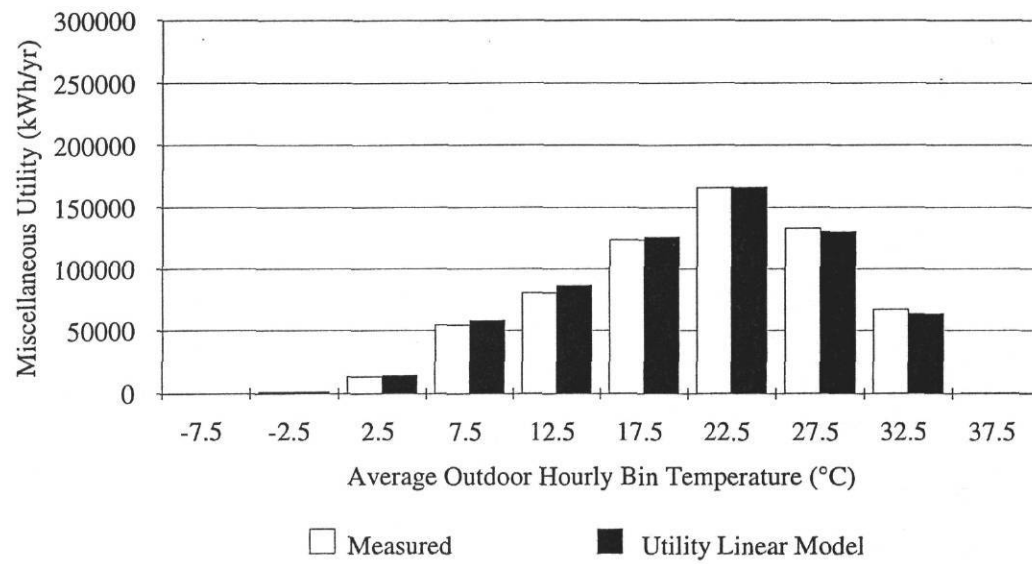
The largest day-to-day variations in the lighting load are due to lights being left on at times when they should not be. Beyond this, there is a seasonal variation in the lighting load which is due to the seasonal change in the duration of daylight. As mentioned earlier, this produces a false appearance of temperature-dependency in the data. While a temperature change-point model may fit the data fairly well, estimating an *effective* change-point temperature is impossible without having the sub-metered data. Furthermore, such a change-point temperature may be physically meaningless. In an attempt to develop an alternative to the constant linear lighting model, the lighting variation was fit by visual inspection of the sub-metered data to a sinusoidal function of the form,

$$E_{\text{LIGHTS}} = a + b \cdot \text{Sin}((N + \Delta) \cdot 2\pi/365) \quad (5.2)$$



**Figure 5.14**

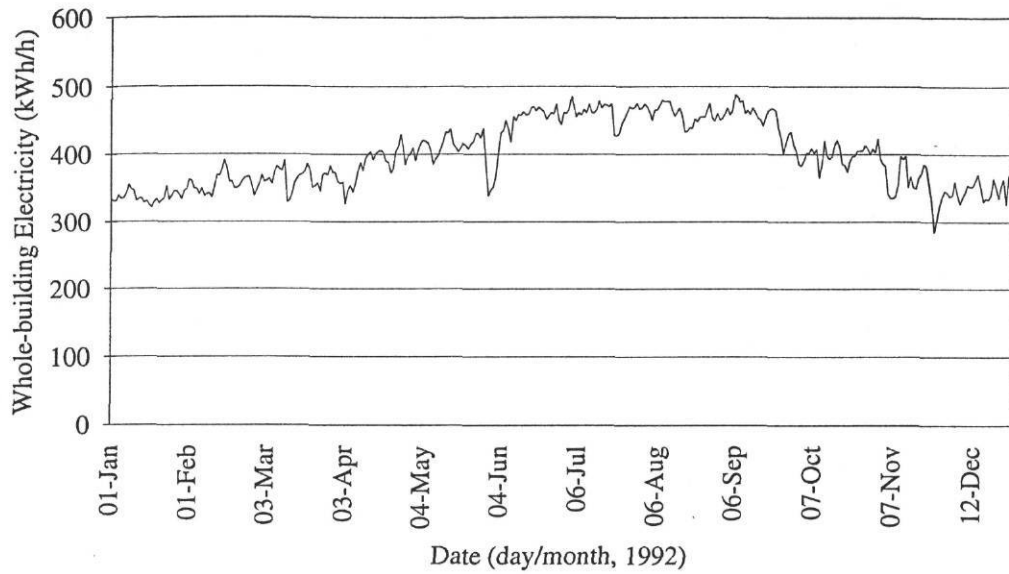
*Time series plot of daily average miscellaneous utility load for 1992 for College Station. The slight drop in consumption near the end of November is due to a partial store shut down on Thanksgiving.*



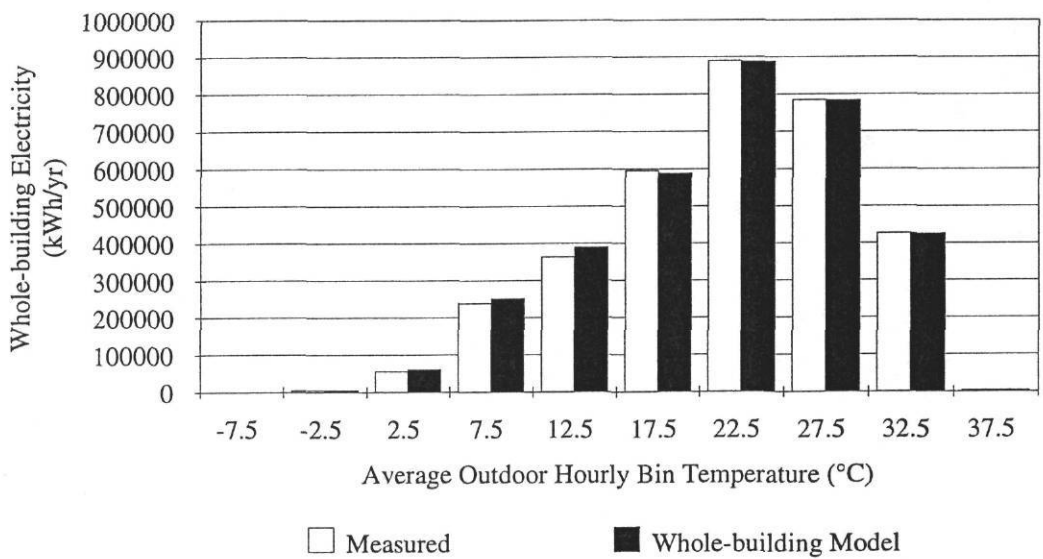
**Figure 5.15**

*Binned hourly electricity consumption for constant linear miscellaneous utility model from 01/01/92 to 01/01/93 for College Station.*





**Figure 5.16** Time series plot of daily average whole-building load for 1992 for College Station.



**Figure 5.17** Binned hourly electricity consumption for four-parameter whole-building model from 01/01/92 to 01/01/93 for College Station.

where the variable,  $N$ , is the day of the year. The parameter,  $\Phi$ , is the day (or horizontal) offset of the sine function,  $a$  is the vertical offset, and  $b$  is the amplitude of seasonal variation. By visual inspection of the sub-metered data, these parameters were estimated to be,

$$a = 124 \text{ kW}$$

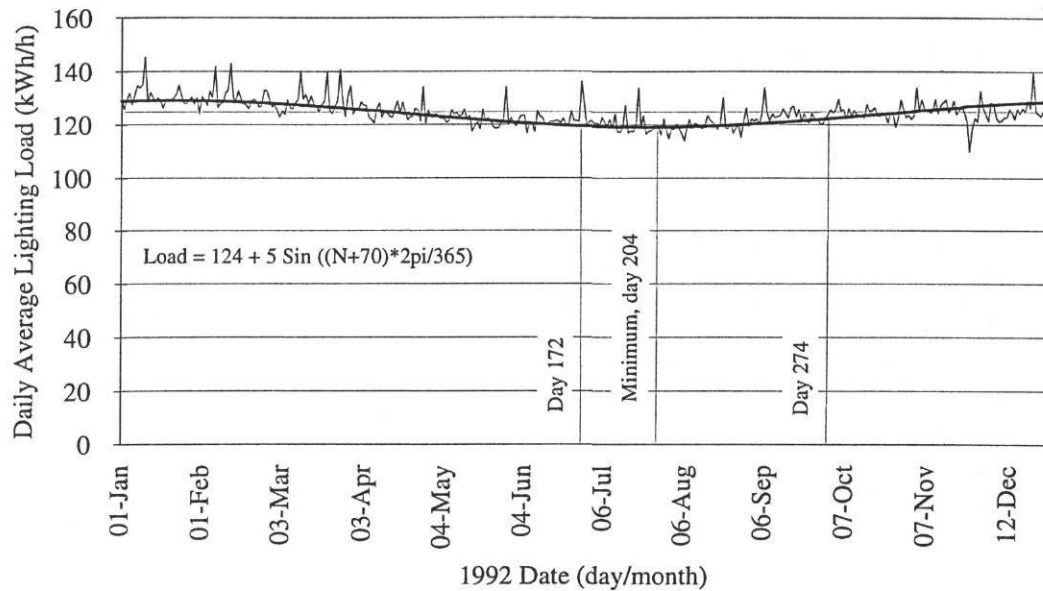
$$b = 5 \text{ kW}$$

$$\Delta = 70 \text{ days.}$$

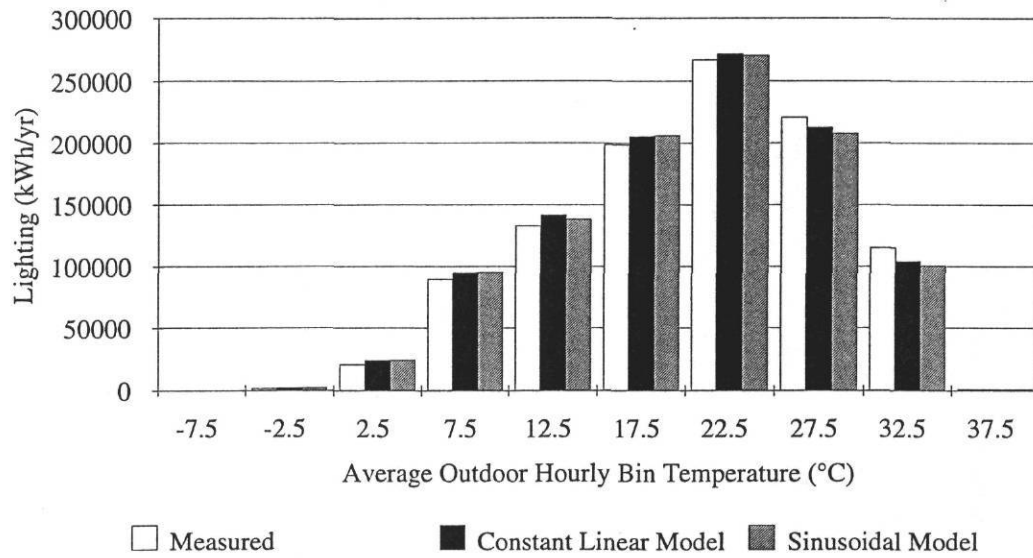
Section 5.3.1 describes how this model could have been estimated without the benefit of sub-metered data. Figure 5.18 shows the seasonal variation in the lighting load as well as the sine model identified for it. The day offset,  $\Delta$ , can be determined by knowing that the longest day of the year occurs on June 21 (day 172), the summer solstice. If a sinusoid starts on January 1, that is to say it crosses the x-axis at this point, its minimum occurs on October 1 (day 274). But, the sinusoidal pattern of the Earth's solar equinoxes does not start on January 1. Its starts on day 102, April 12. This implies an offset between June 21 and October 1 of 102 days. But, the data indicate that *as far as the store's lighting system is concerned*, the longest day occurs near July 23 (day 204). This implies an offset between July 23 and October 1 of 70 days.

One possible explanation for the 32-day difference between the day of the minimum lighting load (July 23) and the summer solstice (June 21) is that the outdoor lighting system depends on the store management adjusting the timer clock for the length of day. This is routinely done about once a month. This lag of one month may explain why the lighting system minimum lags the summer solstice by about a month.

Because the sine model is a function of *the day of the year*, and not of temperature, it cannot be implemented using only binned degree-hours for the full year. Instead, it must be evaluated for each month, and multiplied by the hours in each monthly temperature bin in order to simulate a bin temperature model. This was done for all twelve months in 1992. The predicted lighting energy consumption for each temperature bin was summed over each month to get an annual bin energy consumption. This binned consumption is shown in Table 5.6 and Figure 5.19, and is



**Figure 5.18** *Diurnal pattern of lighting load and sine lighting model, 1992 for College Station. The periodic variation in the lighting load has its minimum near July 23 (day 204) rather than at the longest day of the year, June 21 (day 172). The management adjusts parking lot light timer monthly, after noticing that the lights fail to turn on at the appropriate hour. This explains the 32-day lag.*



**Figure 5.19** *Binned annual electricity consumption for sine and constant linear lighting models, 1992 for College Station.*

**TABLE 5.6**  
Annual Summary of Sine Model and Four-P Model for Lighting

Temperature (°C)			Hours	kWh (data)	Sine Model		4-P Model			
low	high	avg			kWh	Diff	kW	kWh	Diff	
-10	-5	-7.5	0	0	0		125	0		
-5	0	-2.5	19	1791	2436	36.05%	126	2396	33.79%	
0	5	2.5	188	20725	24096	16.27%	127	24347	17.48%	
5	10	7.5	744	89671	95301	6.28%	128	97180	8.37%	
10	15	12.5	1082	132959	138395	4.09%	128	145831	9.68%	
15	20	17.5	1633	198963	206538	3.81%	127	210419	5.76%	
20	25	22.5	2185	266779	270467	1.38%	124	270925	1.55%	
25	30	27.5	1708	221175	208065	-5.93%	121	207043	-6.39%	
30	35	32.5	835	115270	100737	-12.61%	118	98618	-14.45%	
35	40	37.5	8	1124	958	-14.77%	115	920	-18.19%	
Total:				1048457	1046993	-0.14%		1057678	0.88%	

compared to the sub-metered lighting data for each bin. Also shown are the bin predictions of the constant linear lighting model. On the whole, the annual sum of the sine model differs from the annual sum of the measured data by only 0.14%. The annual sum predicted by the linear model differs by 0.88%. The sine model fits the lighting data with a  $CV_{RMSE}$  of 3.12%. The linear lighting model fits the lighting data with a  $CV_{RMSE}$  of 4.1%. This sine model can be used in place of the linear model in the bin application by multiplying its predictions (kW) by the hours in each temperature bin. Because it is *not* a temperature model, it has the appeal of not requiring the estimation of an effective change-point temperature. The sine model has a shortcoming, though; its parameters could not be identified in an objective manner without detailed information, such as sub-metering, about the lighting load schedules. Thus, since its performance was only marginally better than that of the constant linear lighting model, we decided that the linear model was adequate for the bin modeling.

### 5.3 ALTERNATIVES TO SUB-METERING FOR THE COLLEGE STATION STORE

We have seen that sub-metering can be used to provide energy consumption data for both specific component loads and well as whole-building loads. In addition, sub-metered data provides a means of identifying statistical models for use in binned load prediction. Unfortunately, sub-metering can be expensive. If there are other means of identifying component electricity loads, then they are worth pursuing. This

section investigates some of the possible approaches to estimating component loads without the use of sub-metering.

### 5.3.1 Base Loads

The easiest electricity loads to estimate are those which do not vary, or those of which the variation is periodic and predictable in some way. For the College Station store, the lighting and miscellaneous utility loads have this quality. Therefore, we decided that it was worthwhile to see if information from a few site visits could be used to replace the expensive sub-metering which had been used to identify the component load models.

From the time-series plots in Figures 5.3, 5.5, 5.10 and 5.14, we can see that the lighting and utility loads are fairly constant from day to day over a wide range of temperatures. To estimate these base component loads, an energy use survey was performed.<sup>8</sup> Information in the survey was comprised of nameplate readings of electrical equipment as well as actual clamp-on measurements of easily identifiable electrical loads.

**Walk-through Survey Procedure.** In order to estimate energy use in the store, the following simple walk-through energy use survey procedure was followed.

- 1) The lighting load was estimated by a walk-through fixture count. Information on lamp wattages was obtained from stored replacement lamps. Parking lot lights exhibit a seasonal behavior since they are on a timer which is adjusted monthly to account for the changing length of night-time hours throughout the year. Daily interior and exterior lighting scheduling information, obtained in conversations with the store manager, was taken into consideration when determining the average daily lighting load. The information provided by the fixture count could also have been obtained by clamping the various electrical distribution panels which make up the lighting circuit; however, this might have taken more time as a fixture count.
- 2) Miscellaneous utility loads were also gauged by a walk-through nameplate survey. However, by comparing the nameplate totals to the sub-metered utility energy use, we found that nameplate data did not accurately represent actual energy use. Since the utility load is fairly constant throughout the year, clamp-

---

<sup>8</sup> See Section 3.1 and Appendix B for detailed results of the survey.

on watt-meter readings taken on the main utility circuit panel could have been used to accurately gauge the daily energy use. See Appendix B for a detailed listing of lighting and utility loads.

- 3) HVAC fan loads were determined by using clamp-on amp readings.<sup>9</sup> This information was also available from nameplate data, however the amp readings indicated that the HVAC components do not all run at full rated load. The fans run at about 80% of their nameplate load, and were measured to have a total power draw of about 25 kW.

**Lighting.** The lighting count can be used to estimate the peak lighting load. Indeed, the peak nameplate lighting load is estimated to be 177 kW. In Figure 5.20, we can see that the sub-metered, maximum *hourly* lighting load is about 175 kW. But, as determined previously, the daily average lighting load is 124.7 kW. Thus, partial load fractions were determined based on the daily lighting schedules as follows:

Load Description	Hours on	Load fraction
Overhead sales area lighting	6 a.m. to 12 a.m.	0.75
Overhead non-sales	7:30 a.m. to 12 a.m.	0.70
Display cases	6 a.m. to 12 a.m.	0.75
Misc. non-fluorescent sales	8 a.m. to 12 a.m.	0.67
Video store sales area	8 a.m. to 1 a.m.	0.70
Parking lot (on average)	6 p.m. to 6 a.m.	0.50

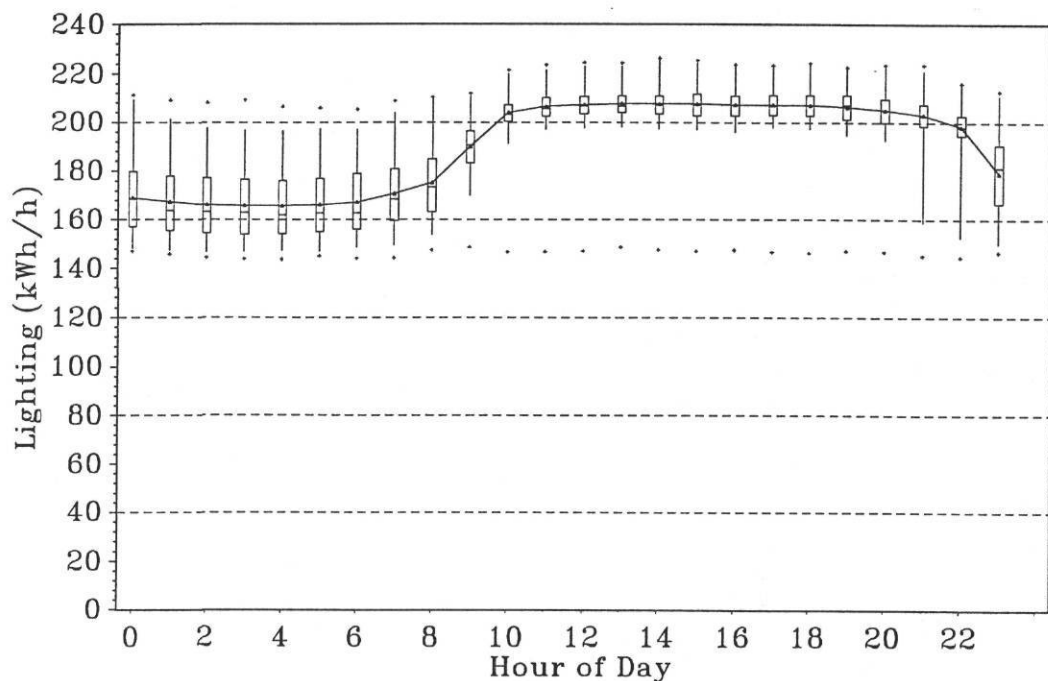
When multiplied by the peak lighting load, the result is an average daily lighting load of 126.1 kW. This is close to the average 124.7 kW. Compared to the peak load, this amounts to a diversity factor of about 71%. The walk-through survey seems to give values of peak and average energy use which are in fair agreement with the sub-metered data. As can be seen in Figure 5.20, which depicts statistical box plots of the hourly lighting load profile (based on a full year of lighting data), there are three primary schedules of hourly lighting energy use which depend on the time of day. Clamp-on measurements of these loads could be obtained by measuring the main lighting circuit panel at times when each lighting schedule is known to be in effect (see Figure 5.21). In this case, the times to measure are 3 a.m., noon, and 10 p.m. The

<sup>9</sup> Clamp-on readings are made using a hand-held amp meter which, when placed around an electrical conductor, determines the amount of current flowing in that conductor.

average daily load could then be calculated based on knowledge of the schedule time periods. Alternatively, temporary sub-metering could be installed on the lighting distribution panels for one week.

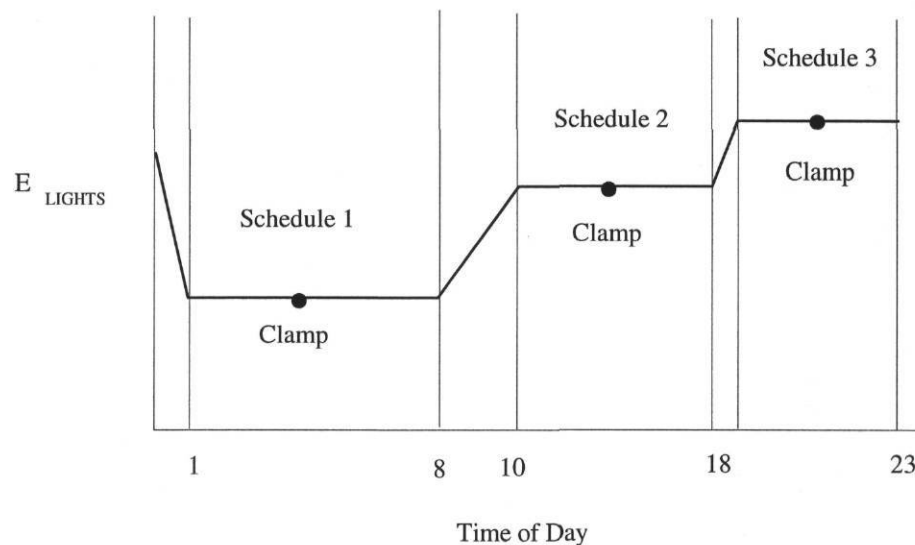
The parameters of the sinusoidal lighting model -- average base, amplitude of variation, and day offset -- were found by visually examining the sub-metered data. We have already seen that the offset of the sine function is 70 days. With knowledge of the store's operating procedures, the 70-day offset might have been estimated without sub-metered data, but this estimation would not have been repeatable, and would have relied on subjective judgment. When daily light schedules are available, the average daily load and amplitude of variation can be estimated as described above. The average of the sub-metered data is 124 kW, and the load estimated from the walk-through lighting count, accounting for lighting schedules, is 126 kW. So, an estimate for the mean of the sinusoid may be found without sub-metering. The amplitude of the sinusoid may be found by estimating the variation in the outdoor lights due to the variation in their cut-on time. The store management claims that the outdoor lights are needed as early





**Figure 5.20**

*Box plot of the hourly lighting load profile for the period 01/01/92 to 01/01/93 for College Station. This plot depicts the average hourly load profile for the store. Box whiskers and outliers indicate the extremes of the data. A peak load of about 175 kW can be seen at 11:00 a.m., when parking lot lights had been left on during the day. The relatively long upper whisker lines seen between the hours of 1:00 a.m. and 8:00 a.m. indicate that some of the store's indoor lights are occasionally left on during those hours. The band of lower outliers during the afternoon hours represent the load on Christmas day, when the store is closed.*



**Figure 5.21** *Hourly lighting schedule with preferred times for clamp-on load measurements for College Station store. This plot shows times at which the three schedules of the lighting load at the College Station store could be measured to determine the average daily lighting load.*

as 5:00 p.m. and as late as 9:30 p.m. -- a range of 4.5 hours. They shut off as early as 6:00 a.m., and as late as 8:00 a.m. -- a range of two hours. The peak connected load of the outdoor lighting system is 27.6 kW. Over a total of 6.5 hours, this amounts to a range of 179 kWh/day, or an average range of 7.5 kWh/h. This is 75% of the range estimated by visual inspection of the data (10 kW).

While the development of the sinusoidal lighting model is an admirable exercise in deductive reasoning, the sinusoidal model is only marginally superior to a constant linear lighting model. Due to the amount of work involved, we chose to use the linear model for further analysis. Regardless of which model is used, long-term electrical sub-metering is not necessary to estimate the lighting load.

**Miscellaneous Utility.** The peak miscellaneous utility load is 130 kW according to nameplate data. However, different components of this load are never all on at the same time. The sub-metered data serve as a better source of information, and were used to represent what clamp-on measurements could have revealed. The average sub-metered utility load is 76.4 kW, which amounts to a combined diversity and load factor of 58%. Thus, at estimating the utility loads, the walk-through survey would

not have been sufficient unless a diversity/load factor could be accurately assumed. However, since these loads do not vary from day to day, simple clamp-on watt-meter measurements of the utility circuit at various times during the day and night would yield enough data to determine a daily average value.

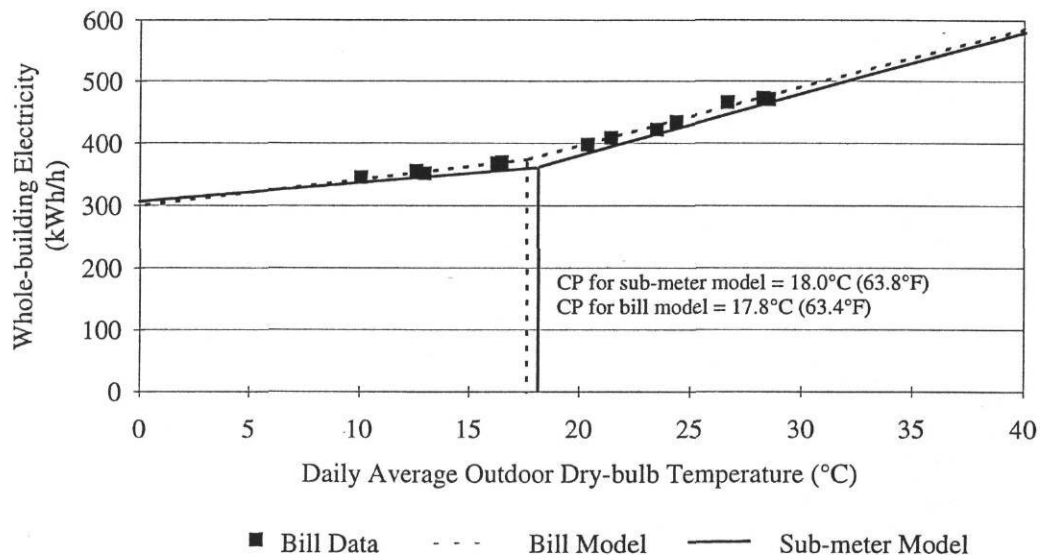
### 5.3.2 Varying Loads

With the base loads determined, the next task is to identify the loads which do not remain constant. Primarily, these are comprised of the HVAC and refrigeration system loads. The two HVAC compressors running at the time of the survey were measured to have a load of about 59 kW. The average outdoor ambient temperature for the day was 28°C (82°F). HVAC compressor and refrigeration compressor loads were measured with clamp-on amp meters. This was preferred to nameplate readings since these systems do not operate at full rated load. But while one-time clamp-on measurements may be valuable for checking assumptions about the HVAC and refrigeration systems, these loads are not constant, and it was not possible to estimate their loads based on a survey alone. A different means for estimating varying loads was necessary.

Monthly whole-building electricity consumption data is readily available from the electric utility. If the refrigeration system load can be estimated, then it is possible to deduce the HVAC load by subtracting the refrigeration and base loads (lighting and utility) from the whole-building consumption. Figure 5.22 shows a whole-building electricity model identified from 12 months of monthly utility bill data as compared to the whole-building electricity model identified from the sub-metered data.

One year's worth of monthly utility billing data was used to identify the whole-building, four-parameter change-point model. The parameters for this model are as follows:

Load	$a_O$ (kWh/h)	$a_{LOW}$ (kWh/h-°C)	$a_{HIGH}$ (kWh/h-°C)	Change-point (°C)
$E_{WHB,bills}$	373.87	3.7785	9.5085	17.8



**Figure 5.22**      *Change-point models identified from utility billing data and sub-metered data for College Station.*

The utility billing model does very well at predicting the data from which it was identified -- the  $R^2$  value is 99% and CV is 1%. It predicts the 1992 sub-metered data with an  $R^2$  value of 87% and a CV of 4%. The average billing period temperature was 20°C (67°F). When a year's worth of sub-metered electricity data are used, the four change-point model parameters are as follows

Load	$a_O$ (kWh/h)	$a_{LOW}$ (kWh/h-°C)	$a_{HIGH}$ (kWh/h-°C)	Change-point (°C)
$E_{WHB.sub}$	363.5	3.0144	9.7477	18.0

The whole-building model constructed from a full year of sub-metered data predicts the *utility billing* data with an  $R^2$  value of 96% and a CV of 3% (which,

incidentally, are better values than the 95% and 3% obtained when predicting the sub-metered data from which the sub-meter model was identified).

When compared to the utility billing model, the full-year model predictions differ by no more than 2.0%, based on the utility billing prediction values. It should be noted that, from comparing monthly utility bills to monthly sums of the sub-metered data, the sub-metered data themselves differ from the public utility's data by about 3%. Since the full-year sub-meter model was derived from the sub-metered data, the 2.0% difference between the models is not surprising. The model constructed from the billing data is almost the same model that could be constructed from sub-metered data. Either whole-building model works well. Thus, expensive sub-metering might be replaced with monthly billing data and information from several site visits.

### 5.3.3 Load Disaggregation

Once the lighting and utility load models were determined, all that was left to determine was the refrigeration compressor load and the HVAC load. While a one-time walk-through survey could not reveal these varying loads in detail, we found it was possible to obtain them by deductive reasoning from information already available.

The whole-building model represents the variation for all the loads combined. This model can be known either from sub-metered, whole-building daily data, or by monthly utility billing data. Using the utility billing model, the whole-building electricity load at 5°C (40°F) is 325 kWh/h. Figure 5.7 showed that the component electricity loads could be added together to form the whole-building load. At this point, again referring to Figure 5.7, we already have curves A, B, and D *without the use of sub-metering*.<sup>10</sup> The task then is to estimate curve C from either name-plate or clamp-on measurements. The difference between curves C and D is the store's HVAC load, and between curves C and B is the store's refrigeration compressor load. If estimates of the maximum and minimum HVAC loads can be made, they can be subtracted from each end of the whole-building model curve (curve D) to obtain two points which define a line that is a proxy for curve C.

---

<sup>10</sup> Curve A represents only the miscellaneous utility load. Curve B is the sum of the utility load model and the lighting model. Curve C is the sum of the utility, lighting, and refrigeration models; and curve D is the sum of the utility, lighting, refrigeration, and HVAC models. Curve D coincides with the whole-building model (i.e., the dashed line).

From Figures 3.12 and 3.13 in Chapter 3, it can be seen that at temperatures of 5°C (40°F) or lower, the only HVAC load is that of the air-handler fans. Both sub-metering and clamp-on measurements reveal the main store air-handler fan load to be about 25 kW. Clamp-on readings on the video store HVAC load indicate a 3 kW base fan load. There are two dairy refrigeration compressors on the HVAC circuit with a peak load of 11.5 kW. At 5°C, they are estimated to be at about half load. If we subtract these loads from the whole-building model at 5°C, we get 290 kW, which *should* be curve C at 5°C. In Figure 5.23, this subtraction is shown. From curve C, the sub-metered refrigeration compressor load is 291 kW at 5°C (40°F). The agreement is impressive.

Clamp-on watt measurements for the HVAC system were taken on a day when the average daily temperature was 28.1°C (82°F). Whole-building electricity use at this point is 472 kW, based on the utility billing model. The load for the HVAC channel consisted of about 25 kW of fans, 58 kW in two compressors, 11.5 kW of dairy compressors, and about 40 kW in the video store HVAC systems, totaling 135 kW. If we subtract this from the whole-building model at 28.1°C, we get 337 kW. If the estimation of the HVAC load is accurate, this should represent the sum of all loads except HVAC. In Figure 5.24, curve C shows the sum of the sub-metered non-HVAC loads (refrigeration load plus base loads) to be 332 kW at 28.1°C. *This agrees with the subtracted value of 337 kW to 1.5%*. A proxy for the refrigeration curve C can then be interpolated between the points at 5 and 28.1°C. This curve is given by,

$$C_{\text{proxy}} = 280.2 + 2.036 T \quad (5.3)$$

where T is the outdoor temperature.  $C_{\text{proxy}}$  represents the proxy model for the *sum* of the lighting, utility, and refrigeration loads. Proxies for the HVAC and refrigeration models can then be determined by subtraction.

$$E_{\text{HVAC}} = \text{Whole-building utility billing model} - C_{\text{proxy}} \quad (5.4)$$

$$E_{\text{COMP}} = C_{\text{proxy}} - \text{Lighting model} - \text{Utility model} \quad (5.5)$$

Predictions for HVAC and refrigeration compressor energy use based on these proxy models were compared to the HVAC and refrigeration models developed from the sub-metered data. The results are as follows:

	Data	Proxy Model		4-P CP	
	Mean	R <sup>2</sup>	CV	R <sup>2</sup>	CV
<b>Refrigeration Compressors:</b>	114.2	63%	8%	86%	5%
<b>Combined-store HVAC:</b>	84.0	90	14	91	14

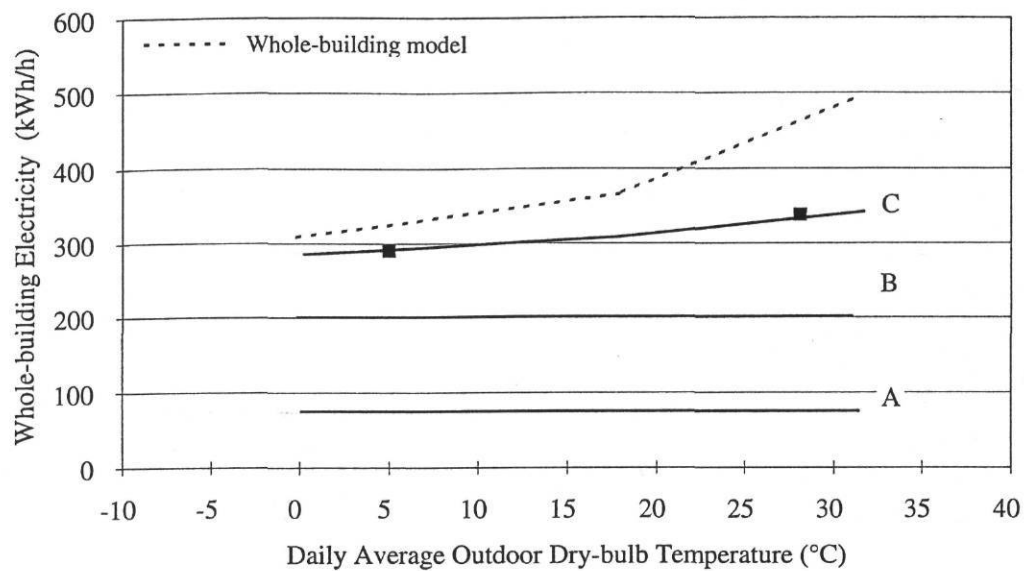
There are several sources of data from which change-point models can be identified. Sub-metering unquestionably gives the best data. But, for the case of constant base loads, the data vary by less than 10% of the mean. Thus, one-time clamp measurements can give base load data that are within 10% of the average which would be provided by a year's worth of sub-metered data. And, when it is possible to accurately model base loads of a grocery store, and when the whole-building load model is known, it is possible to use one-time clamp-on readings to disaggregate the data and determine models for the two remaining, temperature-dependent loads. Table 5.7 lists the loads of interest in the College Station grocery store and how the data and models for them were obtained.

To further test the concept of an end-use model derived from monthly billing data and information from several site visits, the basic temperature change-point and bin analysis performed on the College Station store was also performed on the Bryan store. Only the results and relevant differences will be presented here.

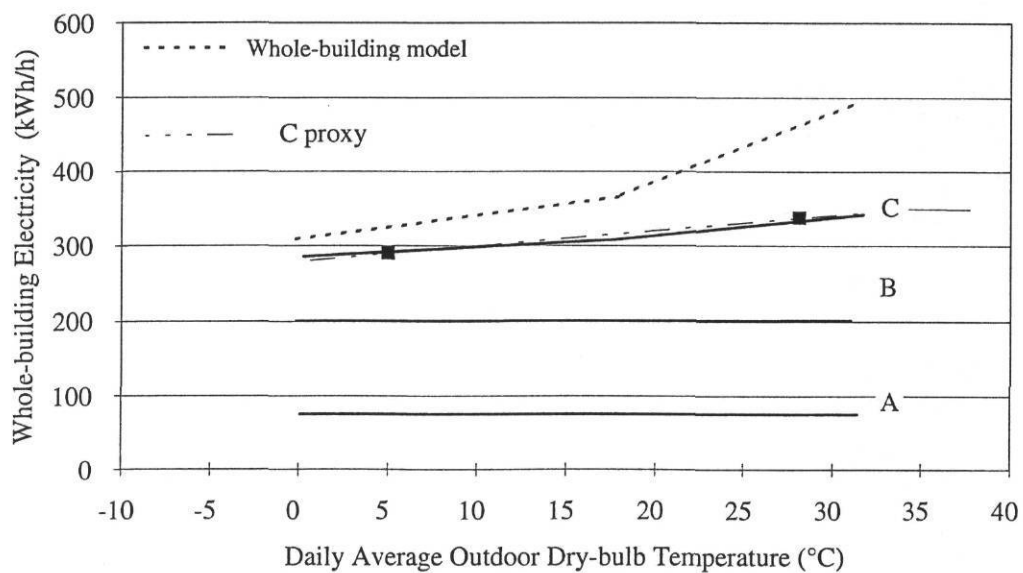
TABLE 5.7  
Sources of Model Identification Data for College Station Store

Load	Where obtained	Comments
Whole-building electricity	monthly utility bills	full year's worth
Miscellaneous utility	site visit	clamp-on watt meter readings or nameplate
Lighting	site visit	clamp-on watt meter readings or nameplate
HVAC	site visit	use clamp-on watt meter readings at various temperatures
Refrigeration compressors	site visit	use disaggregation and clamp-on watt measurements at various temperatures





**Figure 5.23** Model disaggregation showing maximum and minimum HVAC loads subtracted from whole-building model for College Station.



**Figure 5.24** Model disaggregation showing curve,  $C_{proxy}$ , for College Station.

#### 5.4 MODEL OVERVIEW FOR THE BRYAN STORE

Using the change-point selection methods outlined for the College Station store, four-parameter change-point and constant linear models were developed for the whole-building electricity and the four sub-metered loads at the Bryan grocery store. It should be noted that only six months of sub-metered data were available at the time of this analysis, and that the energy end-uses in the Bryan store are not as cleanly divided by the four sub-metering categories. But since this represents a very real situation which may be encountered, the effort was made to model the Bryan store using the same procedure as used for the College Station store. Based on the experience with the College Station store, three-parameter and sinusoidal models were not considered. The models identified are summarized according to  $R^2$  values (where applicable) and coefficient of variation as follows (the statistics for the models chosen are underlined):

	Data		Simple linear		3-P CP		4-P CP	
	Mean	CV	$R^2$	CV	$R^2$	CV	$R^2$	CV
<b>Refrigeration Compressors:</b>	139.5	13%	94%	3%	95%	3%	<u>97%</u>	<u>2%</u>
<b>Lighting:</b>	<u>190.2</u>	4	50	3	50	3	54	3
<b>Combined-store HVAC:</b>	24.9	80	76	40	86	30	<u>88</u>	<u>28</u>
<b>Miscellaneous Utility:</b>	<u>57.6</u>	<u>9</u>	53	6	82	4	82	4
<b>Whole-building:</b>	412.2	11	86	4	91	3	<u>94</u>	<u>3</u>

The choice of which model to use for subsequent analyses was made by selecting the model with the best  $R^2$  and CV values, as well as intuitive knowledge of the nature of some of the component loads in the store. Empirically, the models chosen for the component and whole-building loads are as follows:

Load	$a_O$ (kWh/h)	$a_{LOW}$ (kWh/h-°C)	$a_{HIGH}$ (kWh/h-°C)	Change-point (°C)
$E_{COMP}$	131.0	1.7789	3.5140	16.1
$E_{LIGHTS}$	190.2			
$E_{HVAC}$	17.25	1.1186	5.3655	18.7
$E_{UTIL}$	57.6			
$E_{WHR}$	402.6	3.8508	12.3388	19.2

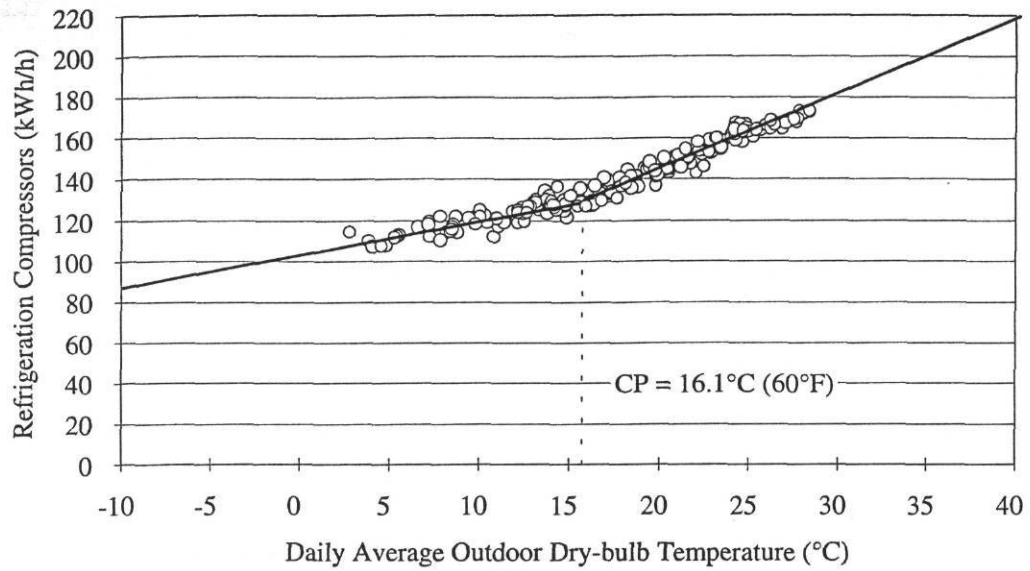
Figure 5.2 shows the refrigeration compressor model and data. Below the change-point temperature (16.1°C [60.4°F]), the slope is less pronounced. There is no heat reclamation in this store. Thus, this change-point was due to the effect of the compressor room exhaust fans which keep the room temperature above 15.9°C (60.1°F). This change-point characteristic is similar to that found in the College Station store.

Figure 5.26 is a plot of the lighting data and the mean lighting load model. It is apparent that the load on the lighting circuit exhibits some temperature dependency. The variation in the lighting load is not easy to explain. All lighting loads in the store run on a set schedule.<sup>11</sup> As discussed in Chapter 3 (Section 3.7), there are some refrigeration case heater loads on the lighting circuit. The energy use of some of these heaters seems to be related to the amount of moisture in the air, which is in turn proportional to the outdoor temperature (for the south Texas climate). This may explain the slope seen in the data when plotted against outdoor temperature. It may also be that there is some HVAC load on the lighting circuit.

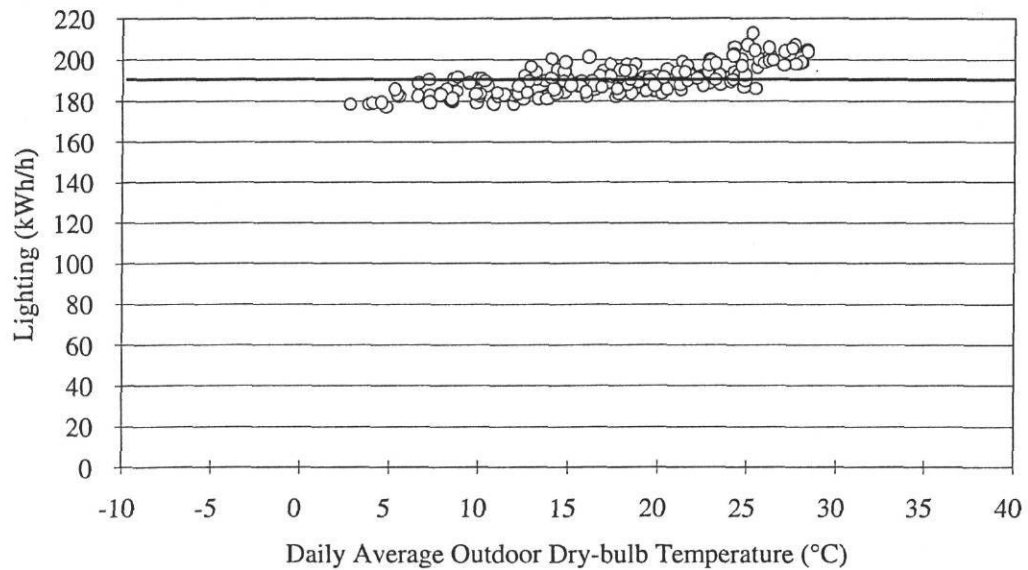
Figure 5.27 shows the HVAC model and data. Unlike for the College Station store, there is no heat reclaim and no dehumidification provided by the Bryan HVAC units. Thus there is no bimodal characteristic on either side of the change-point temperature (18.7°C [60.4°F]).

The miscellaneous utility data and model are shown in Figure 5.28. This energy use is not as constant as it is in the College Station store. This is due to the fact

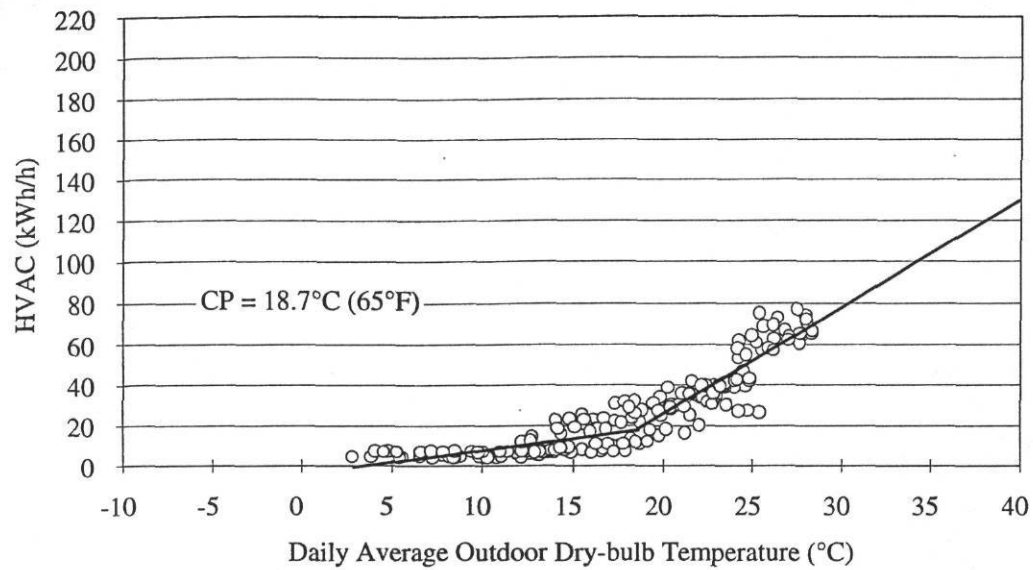
<sup>11</sup> This is in contrast to the College Station store, where the switch-on time for the outdoor lights changes from month to month.



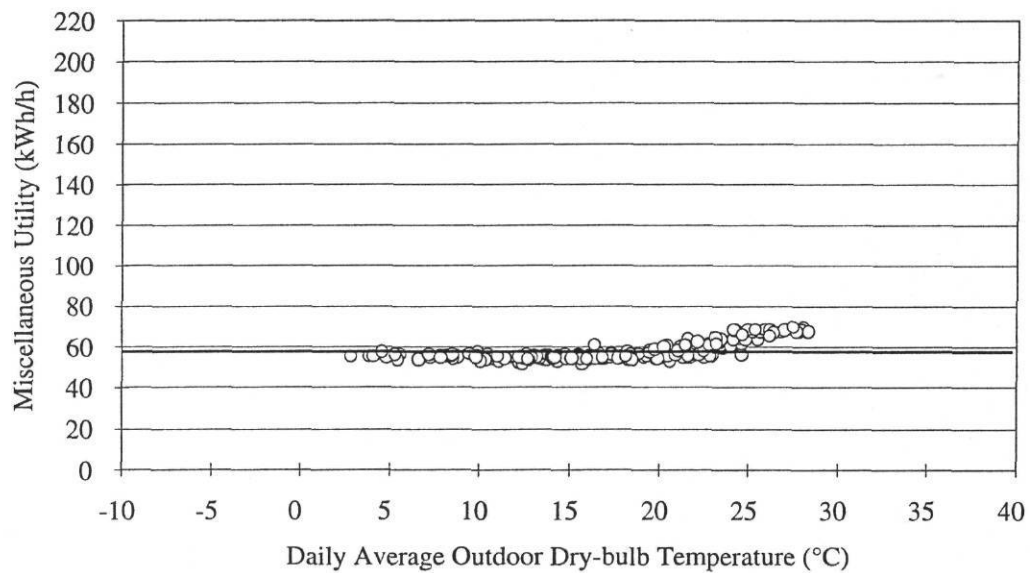
**Figure 5.25** Refrigeration compressor data and temperature change-point model for the period 12/20/92 to 06/28/93 for Bryan store.



**Figure 5.26** Lighting data and constant linear model for the period 12/20/92 to 06/28/93 for Bryan store.



**Figure 5.27** Combined store HVAC data and temperature change-point model for the period 12/20/92 to 06/28/93 for Bryan store.



**Figure 5.28** Utility data and constant linear model for the period 12/20/92 to 06/28/93 for Bryan store.

that there are two HVAC units connected to this circuit. One is rarely used, but represents a potential load of 10 kW. The other, which cools the manager's office, adds about 10 kW to the utility load during peak times, and seems to only run at temperatures above about 20°C (67.4°F). If clamp-on measurements were to be used to gauge the utility load, they would not be able to account for this load unless it was known when it occurred.

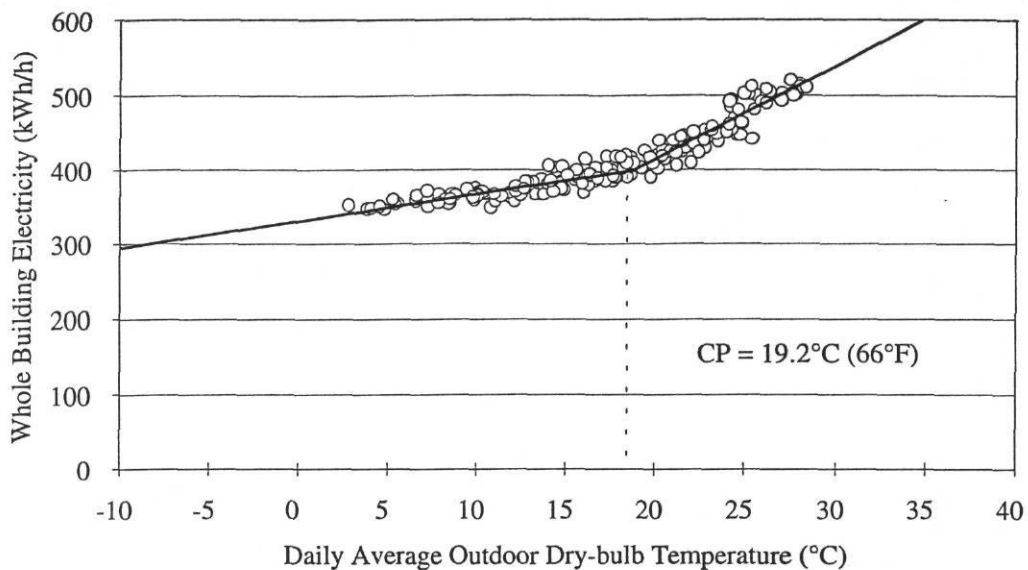
From Figure 5.29 and Figure 5.30, it can be seen how the sub-metered load models can be added together to obtain the whole-building model. Figure 5.29 shows the whole-building model. The change-point of 19.2°C (66°F) is quite noticeable. It is slightly higher than the 16.1°C and 18.7°C change-points associated with the refrigeration and HVAC systems because the whole-building data include the lighting and utility loads which cause the regression procedure to weigh the data differently. This results in a different change-point temperature for the whole building.

In Figure 5.30, curve *A* represents only the miscellaneous utility load. Curve *B* is the sum of the utility load model and the lighting model. Curve *C* is the sum of the utility, lighting, and refrigeration compressor models; and curve *D* is the sum of the utility, lighting, refrigeration compressor, and HVAC models. Curve *D* does not coincide with the whole-building model as closely for the Bryan store as it did for the College Station store. This is because the lighting and utility models under-predict the data (possible HVAC loads) at higher temperatures. Yet, this shortcoming is a valid test for whether simple clamp-on power measurements can be used to accurately gauge energy use over a range of temperature conditions. In this case, it reveals a shortcoming of the method when end-use loads are not separated on different circuits. There are situations where one-time measurements may not accurately predict the base loads because they are not always connected to dedicated electrical panels.

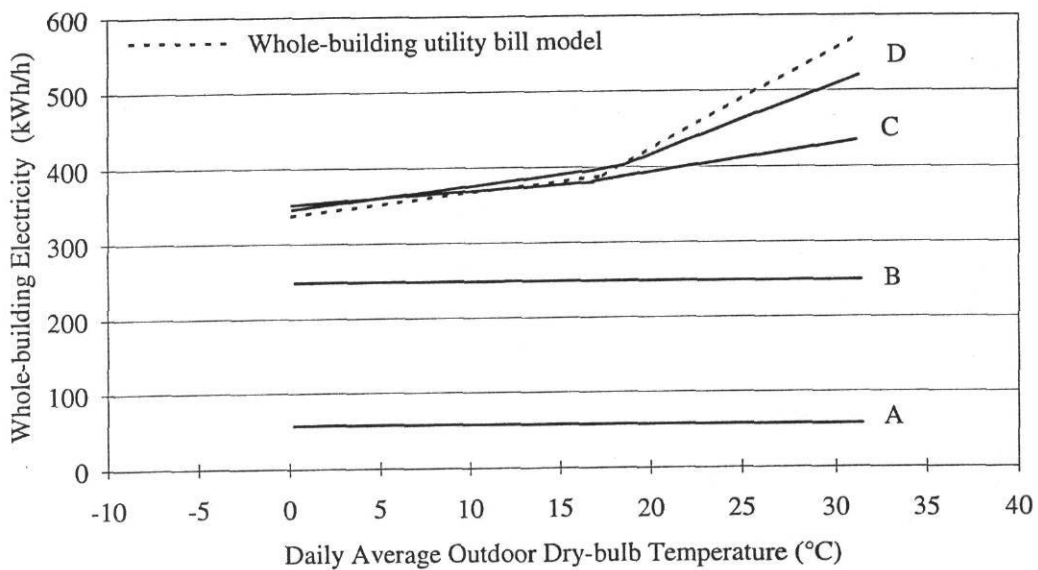
The models developed above were applied to degree-hour bins to predict energy use for any period of time given binned temperature data. This is the subject of the next section.

## **5.5 BIN MODEL APPLICATION FOR THE BRYAN STORE**

With the models identified, all that remained was to apply binned weather data to the models to determine the energy load for any arbitrary period of time. Since bin data were not available for the Bryan area, a program was developed to take hourly weather data, from 12/20/92 to 6/28/93, and group them into bins.



**Figure 5.29** Whole-building electricity data and temperature change-point model for the period 12/20/92 to 06/28/93 for Bryan store.



**Figure 5.30** Addition of sub-metered electricity loads for Bryan store.

The models identified in Section 5.4 predict kilowatts per degree centigrade. When they are multiplied by binned degree-hours, they predict energy use in kilowatt-hours. The bin models were applied to the half year of 1993 binned temperature data, and compared to the measured data for the same period. Results for the component load and whole-building models are shown in Tables 5.8 to 5.12. These tables show the bin hours used, the actual electrical consumption for each bin, and the model predictions of consumption for each bin. Tables 5.8 to 5.12 also show the residual difference (as a percent) between the bin predictions and the data. Two whole-building, semiannual energy consumptions are compared. These are the measured whole-building electricity and the sum of the predictions of the component bin models. There is less than 1% difference between the sub-metered consumption, 1,891,926 kWh, and the predicted consumption, 1,901,784 kWh. Also listed in the table is the total for data which could not be processed by the binning routine. These were energy consumption data for which corresponding hourly temperature data were not available.<sup>12</sup> Their sum is 4,769 kWh. This is a relatively small amount, and does not explain the less than 1% difference between the sub-metered model and the utility billing data.

Figure 5.31 and Figure 5.32 show time-series and bin model predictions for the refrigeration compressors. The bin model predicts the refrigeration load fairly consistently over the entire range of temperatures (-10°C to 40°C). The bin axis labels represent the midpoints of each 5-degree bin. As is the case for all of the subsequent bin plots, the consumption data are slightly skewed towards the higher temperatures in the range. This reflects the behavior of the temperature variable rather than that of the energy consumption. The greatest percent difference for a refrigeration consumption bin is about 3%.<sup>13</sup> However, if the sum of the binned predictions is compared to the semiannual sum of the sub-metered refrigeration data, the difference is less than 1%.

Figure 5.33 shows a time-series plot of the daily average of the lighting data. The daily average of the lighting data tends to increase at time moves from one month to the next. It is difficult to tell if this is a cyclic trend from only six months of data. Figure 5.34 shows the binned hourly lighting load and predictions. Predictions and data within each bin differ as much as 12.5%. However, this occurs in the extreme bins which contain less than 3% of the energy consumption. Above 20°C (67.4°F),

---

<sup>12</sup> Without temperature data, it is not possible to tell in which bin the energy consumption occurred.

<sup>13</sup> Based on sub-metered data for each respective bin.



predictions are consistently greater than the data. Likewise, below 20°C, predictions are consistently less than the data. This is opposite the trend seen in the College Station lighting data. This is due to the fact that we are using a constant model to predict consumption which is not a flat curve, but varies slightly with respect to temperature.

TABLE 5.8  
Bin Simulation for 4-P Refrigeration Model for Bryan Store

Temperature (°C)			Hours	kWh (data)	Refr.		Diff
low	high	avg			kW	kWh	
-10	-5	-7.5	0	0	89	0	---
-5	0	-2.5	0	0	98	0	---
0	5	2.5	192	20960	107	20507	-2.16%
5	10	7.5	583	67311	116	67454	0.21%
10	15	12.5	973	120554	125	121232	0.56%
15	20	17.5	1032	139992	136	140263	0.19%
20	25	22.5	1085	166265	153	166508	0.15%
25	30	27.5	609	103221	171	104148	0.90%
30	35	32.5	120	21877	189	22628	3.43%
35	40	37.5	0	0	206	0	---
Total:				640181 kWh/yr		642740	0.40%

TABLE 5.9  
Bin Simulation for Constant Linear Lighting Model for Bryan Store

Temperature (°C)			Hours	kWh (data)	Lights		Diff
low	high	avg			kW	kWh	
-10	-5	-7.5	0	0	190.2	0	---
-5	0	-2.5	0	0	190.2	0	---
0	5	2.5	192	32725	190.2	36518	11.59%
5	10	7.5	583	104209	190.2	110887	6.41%
10	15	12.5	973	178756	190.2	185065	3.53%
15	20	17.5	1032	195053	190.2	196286	0.63%
20	25	22.5	1085	209982	190.2	206367	-1.72%
25	30	27.5	609	126255	190.2	115832	-8.26%
30	35	32.5	120	26072	190.2	22824	-12.46%
35	40	37.5	0	0	190.2	0	---
Total:				873052 kWh/yr		873778.8	0.08%

TABLE 5.10  
Bin Simulation for 4-P HVAC Model for Bryan Store

Temperature (°C)			Hours	kWh (data)	HVAC		Diff
low	high	avg			kW	kWh	
-10	-5	-7.5	0	0	15	0	0.00%
-5	0	-2.5	19	473	22	423	-10.49%
0	5	2.5	192	5533	29	5597	1.14%
5	10	7.5	762	26366	36	27459	4.15%
10	15	12.5	1137	44613	43	48803	9.39%
15	20	17.5	1651	98402	51	83465	-15.18%
20	25	22.5	2179	201504	90	195185	-3.14%
25	30	27.5	1708	210747	129	219644	4.22%
30	35	32.5	835	127973	168	139961	9.37%
35	40	37.5	8	1318	207	1653	25.46%
Total:				716929	kWh/yr	722189	0.73%

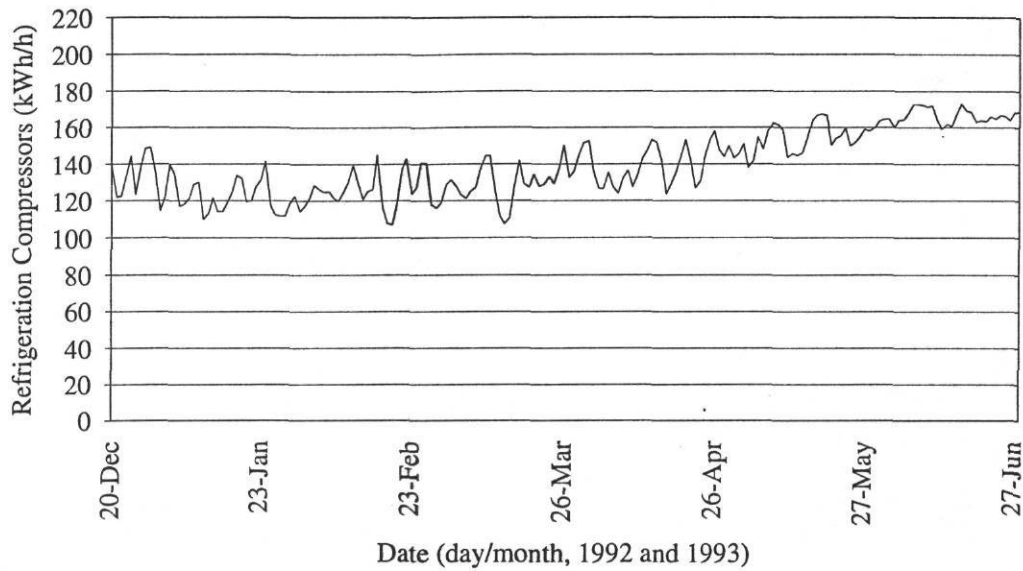
TABLE 5.11  
Bin Simulation for Constant Linear Utility Model for Bryan Store

Temperature (°C)			Hours	kWh (data)	Utility		Diff
low	high	avg			kW	kWh	
-10	-5	-7.5	0	0	-12	0	---
-5	0	-2.5	0	0	-6	0	---
0	5	2.5	192	1087	-1	-159	-114.60%
5	10	7.5	583	3279	5	2779	-15.25%
10	15	12.5	973	8599	10	10080	17.22%
15	20	17.5	1032	20578	16	16463	-20.00%
20	25	22.5	1085	40264	38	41071	2.00%
25	30	27.5	609	32194	65	39391	22.35%
30	35	32.5	120	8566	92	10981	28.19%
35	40	37.5	0	0	118	0	---
Total:				114568	kWh/yr	120606	5.27%

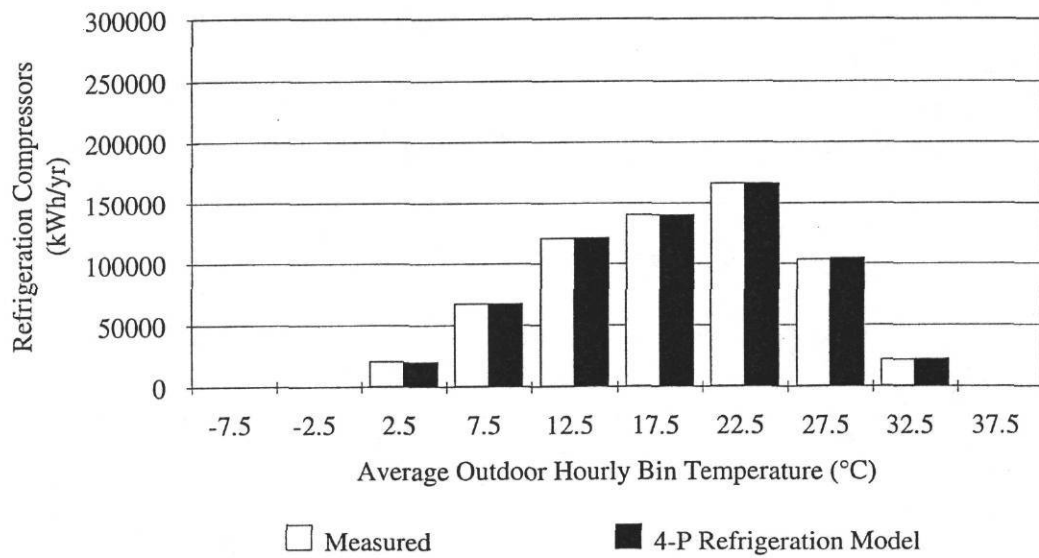
TABLE 5.12  
Summary of Bin Simulation for Component Models for Bryan Store

Temperature (°C)			Hours	Total Data kWh	Model Lighting kWh	Model Utility kWh	Model Refr. kWh	Model HVAC kWh	Total kWh	Diff (%)
low	high	avg								
-10	-5	-7.5	0	0	0	0	0	0	0	----
-5	0	-2.5	0	0	0	0	0	0	0	----
0	5	2.5	192	65586	36516	11063	20507	-159	67928	3.57%
5	10	7.5	583	207144	110881	33592	67454	2779	214706	3.65%
10	15	12.5	973	360948	185055	56064	121232	10080	372431	3.18%
15	20	17.5	1032	413209	196276	59464	140263	16463	412466	-0.18%
20	25	22.5	1085	482327	206356	62518	166508	41071	476453	-1.22%
25	30	27.5	609	298798	115826	35091	104148	39391	294455	-1.45%
30	35	32.5	120	63913	22823	6914	22628	10981	63346	-0.89%
35	40	37.5	0	0	0	0	0	0	0	----
Data Sum:				1891926						
Incomplete Data*:				4769						
Model Sum:					873733	264706	642740	120606	1901784	0.52%

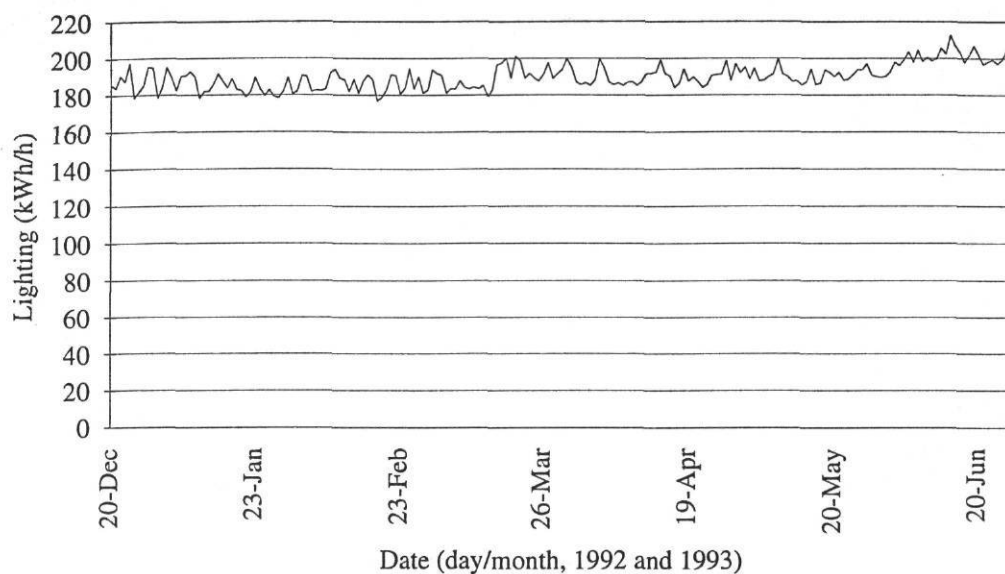
\* Represent consumption data for which corresponding temperature data were not available.



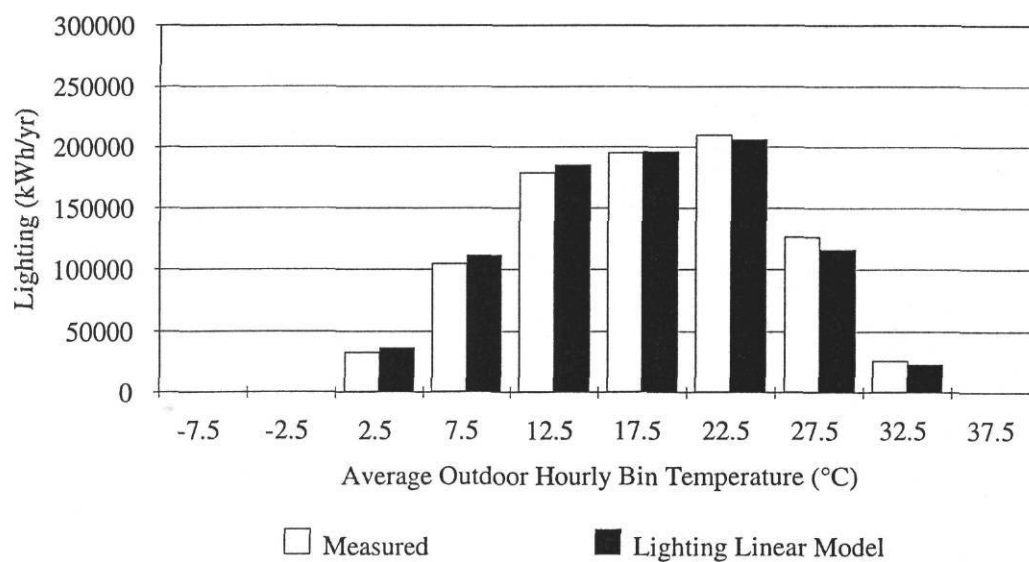
**Figure 5.31** Time series plot of daily average refrigeration compressor load for 1992 for Bryan store.



**Figure 5.32** Binned hourly electricity consumption for four-parameter refrigeration compressor model from 01/01/92 to 01/01/93 for Bryan store.



**Figure 5.33** Time series plot of daily average lighting load for 1992 for Bryan store.



**Figure 5.34** Binned hourly electricity consumption for constant linear lighting model from 01/01/92 to 01/01/93 for Bryan store.

Figure 5.35 and Figure 5.36 are plots of time-series energy use and binned hourly electricity use for the combined-store HVAC system. Differences in binned energy use and predicted energy use are as high as 28% for a particular bin.<sup>14</sup> However, the actual and predicted semiannual energy consumptions differ only by 5.3%. As in the case of the refrigeration system, there is no consistent trend in the differences between the actual and predicted binned energy use.

Figure 5.37 and Figure 5.38 show the miscellaneous utility load as a time-series and binned data plot. The binned energy predictions differ from the binned data by no more than 6.5%, and tend to underestimate the energy use at higher temperatures, while overestimating it at lower temperatures. Semiannual totals differ by only 0.10%

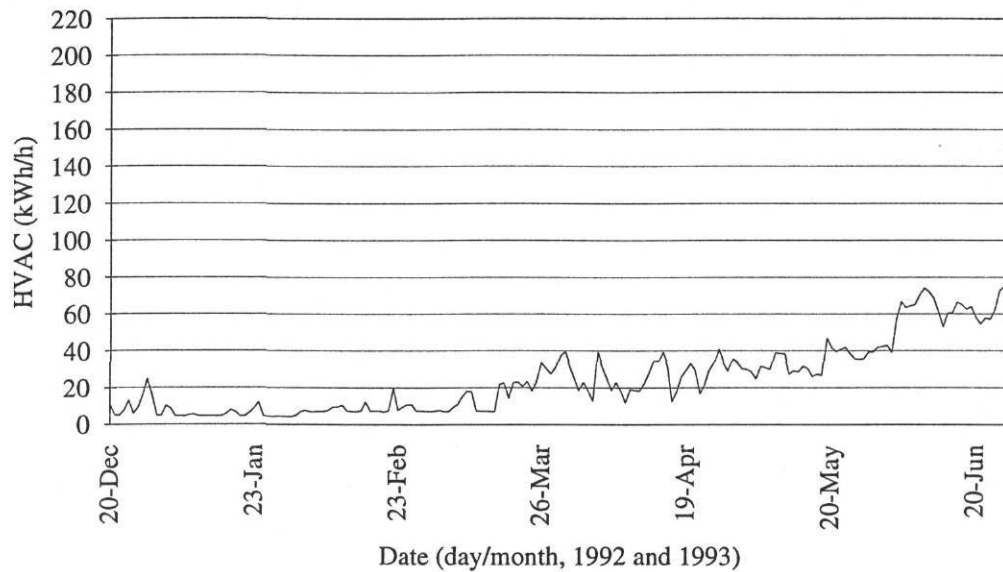
Finally, Figure 5.39 and Figure 5.40 show the time-series plot and binned data and model plot for the whole-building. Bin predictions differ by no more than 6.5% from their corresponding binned data. On the whole, the semiannual sum of the predictions differs by only 0.78% from the whole-building energy use data.

## **5.6 ALTERNATIVES TO SUB-METERING FOR THE BRYAN STORE**

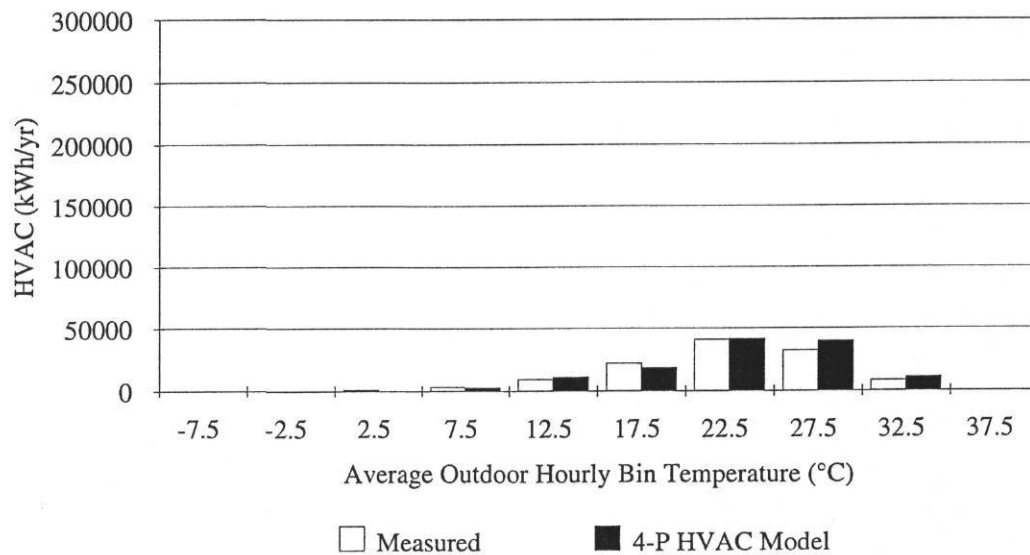
We have seen that sub-metering can be used to provide energy consumption data for both specific component loads and well as whole-building loads. In addition, clamp-on energy use measurements can provide the same information as expensive sub-metering. But, there are limitations to the usefulness of clamp-on readings. This arise primarily when constant component loads cannot be isolated. In the case of the Bryan store, the fact that the lighting and utility loads have some non-constant components makes clamp-on measurements and constant linear models less reliable. Nevertheless, the loads predicted by constant linear models can still be accurate to within 10% of the true average value of the load being studied. The accuracy increases further when long-term energy use is considered (such as semiannual or annual use). To fully evaluate the performance of these models, the sections which follow attempt to disaggregate the whole-building load at the Bryan store using the same methods used in the College Station store.

---

<sup>14</sup> Excluding one bin in which the actual consumption is so small as to make the percent difference 115%. This bin contains only 0.9% of the semiannual energy consumption.

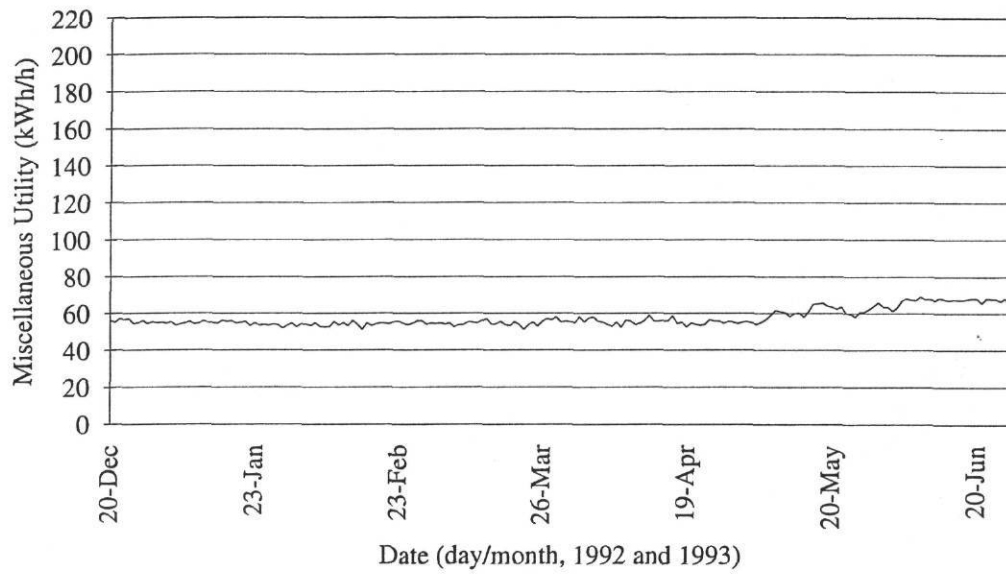


**Figure 5.35** Time series plot of daily average, combined-store HVAC load for 1992 for Bryan store.

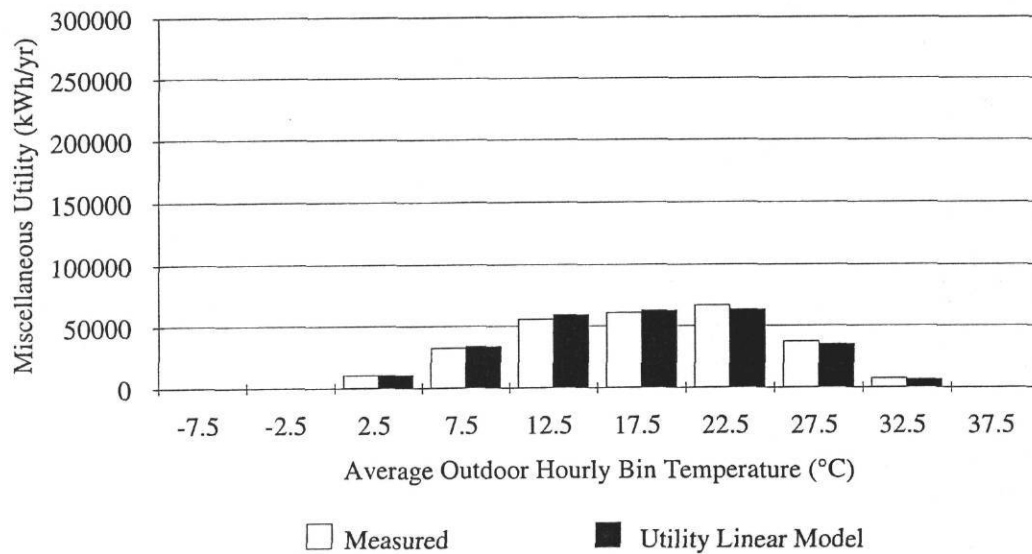


**Figure 5.36** Binned hourly electricity consumption for four-parameter combined-store HVAC model for 01/01/92 to 01/01/93 for Bryan store.

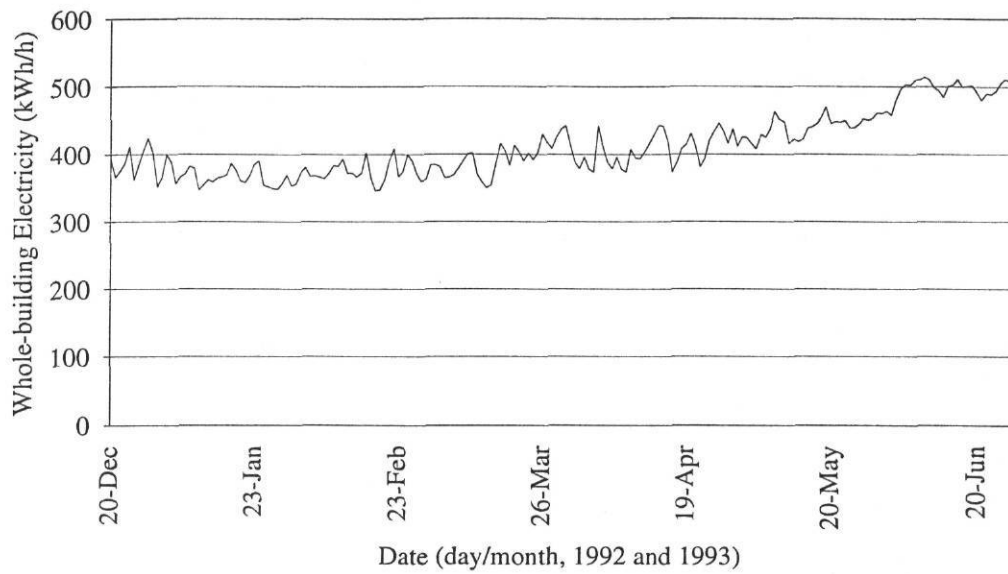




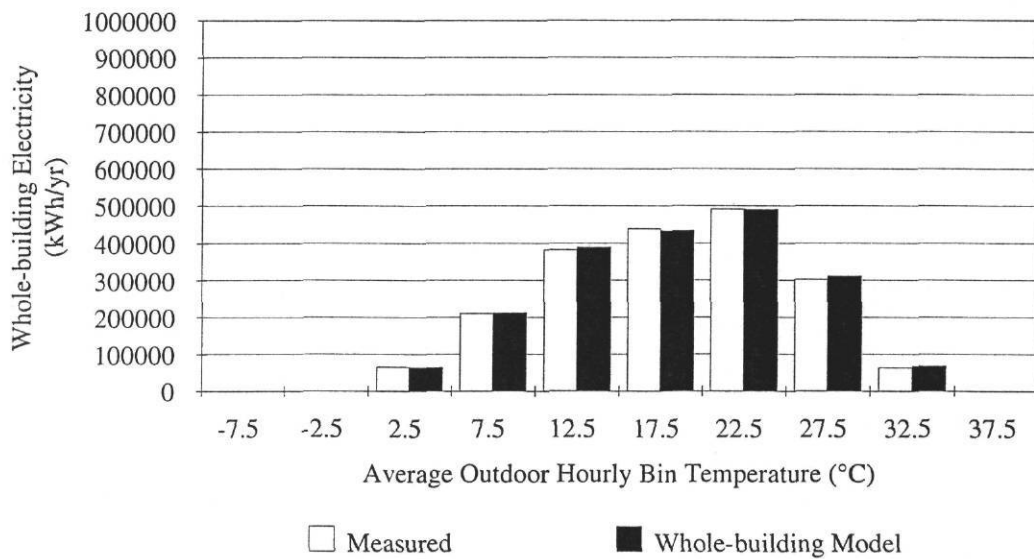
**Figure 5.37** *Time series plot of daily average miscellaneous utility load for 1992 for Bryan store.*



**Figure 5.38** *Binned hourly electricity consumption for constant linear miscellaneous utility model from 01/01/92 to 01/01/93 for Bryan store.*



**Figure 5.39** Time series plot of daily average whole-building load for 1992 for Bryan store.



**Figure 5.40** Binned hourly electricity consumption for four-parameter whole-building model from 01/01/92 to 01/01/93 for Bryan store.

### 5.6.1 Varying Loads

Using the lighting and utility constant linear models identified above for the Bryan store through sub-metering<sup>15</sup>, we proceeded to identify the loads which do not remain constant -- the HVAC and refrigeration system loads. The most previous year's worth of monthly whole-building electricity consumption data was obtained from the electric utility company.<sup>16</sup> This was used to identify the whole-building model as was done for the College Station store. Figure 5.41 shows the whole-building electricity models identified from 12 months of monthly utility billing data as compared to the whole-building electricity model identified from the sub-metered data.

When a year's worth of monthly utility billing data is used to identify the whole-building model, we get,

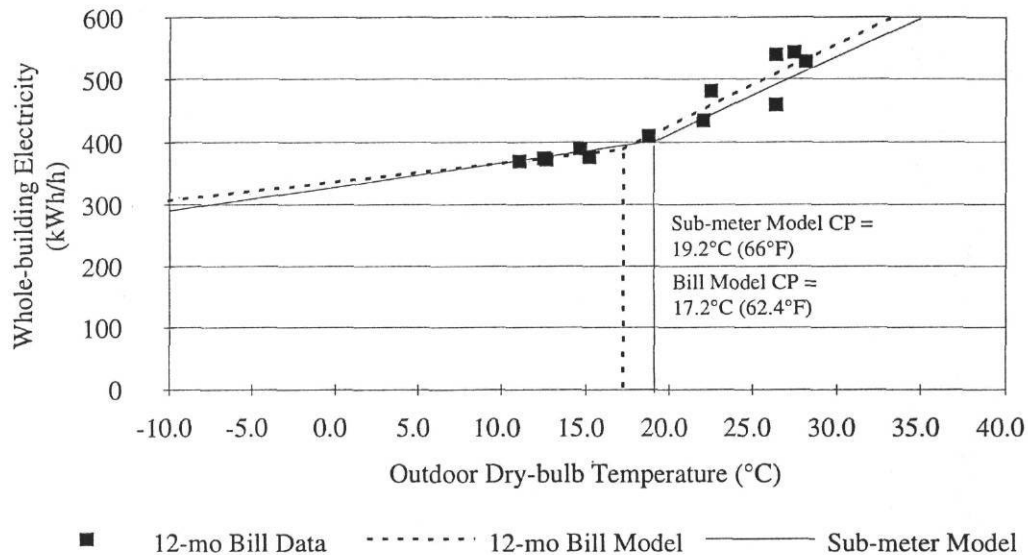
Load	$a_O$ (kWh/h)	$a_{LOW}$ (kWh/h-°C)	$a_{HIGH}$ (kWh/h-°C)	Change-point (°C)
$E_{WHB.bills}$	388.74	2.9951	13.13	17.2

This utility billing data model does very well at predicting the data from which it was identified -- the  $R^2$  value is 91% and CV is 5%. When used to predict the hourly data, the 12-month billing model had an  $R^2$  of 89% and a CV of 4%. When a half-year's worth of sub-metered electricity data are used, the model is,

Load	$a_O$ (kWh/h)	$a_{LOW}$ (kWh/h-°C)	$a_{HIGH}$ (kWh/h-°C)	Change-point (°C)
$E_{WHB.sub}$	402.6	3.8508	12.3388	19.2

<sup>15</sup> Sub-metering is taken to be equivalent to clamp-on energy use measurements for base loads. Since the lighting and utility loads are not completely constant at the Bryan store, there are limitations to the usefulness of one-time clamp-on measurements. These are discussed in the sections which follow.

<sup>16</sup> The period covered was May 1992 to April 1993.



**Figure 5.41** Change-point models identified from utility billing data and sub-metered data for the Bryan store.

This sub-metered data model predicts the hourly data with an  $R^2$  value of 94% and a CV of 2%. Either whole-building model works well. Thus, the utility billing model was used for load disaggregation.

### 5.6.2 Load Disaggregation

All that was left to determine was either the refrigeration compressor load or the HVAC load. The whole-building model represents the variation for all the loads combined. Using the utility billing model, the whole-building electricity load at 0°C (32°F) is 337 kWh/h. Figure 5.30 showed that the component electricity loads could be added together to total the whole-building load. At this point, again referring to Figure 5.30, we already have curves A, B, and D *without the use of sub-metering*. The task then is to estimate curve C from either name-plate or clamp-on measurements. The difference between curves C and D is the store's HVAC load. If estimates of the maximum and minimum HVAC loads can be made, they can be subtracted from each end of the whole-building model curve (curve D) to obtain two points which define a line that is a proxy for curve C.

From Figures 3.28 and 3.29 in Chapter 3, it can be seen that at temperature of 0°C or lower, the only HVAC load is that of the air-handler fans. Both sub-metering and clamp-on measurements reveal the store's HVAC fan load to be about 5 kW. If we subtract this load from the whole-building model at 0°C, we get 332 kW, which *should* be curve C at 0°C. In Figure 5.42, this subtraction is shown. From curve C, the sub-metered refrigeration compressor load is 350 kW at 0°C (32°F). The agreement is not as remarkable as it is for the College Station store, but the proxy value is within 5.1% of the value of curve C at 0°C.

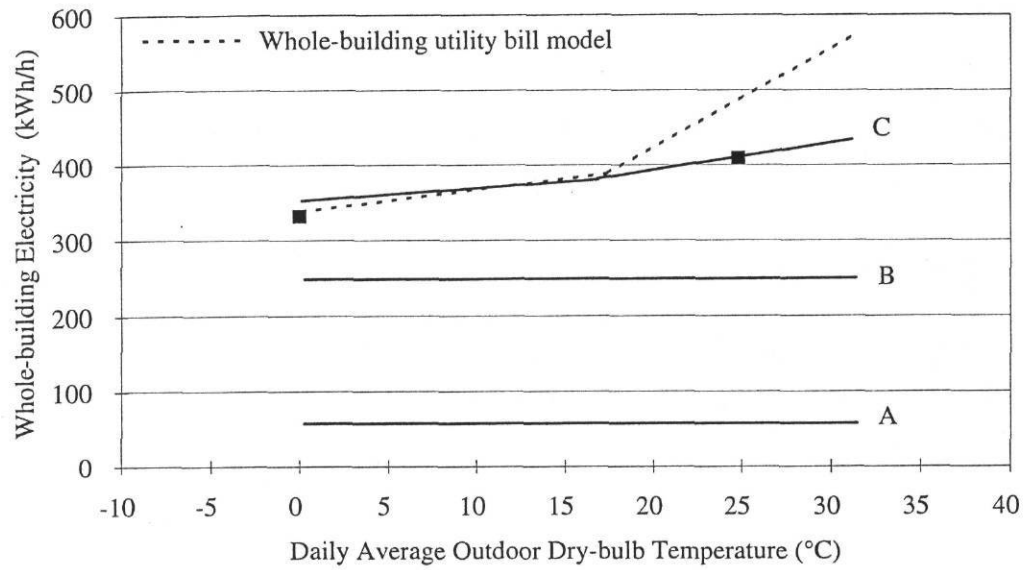
Clamp-on measurements of the HVAC system were taken at an outdoor ambient temperature of 24.8°C (76°F). At this temperature, the HVAC load was 78.5 kW. Whole-building electricity use at this point is 488 kW. If we subtract the HVAC load from the whole-building model at 24.8°C, we get 409.3 kW. If the estimation of the HVAC load is accurate, this should represent the sum of all loads except HVAC. In Figure 5.43, curve C shows the sum of the sub-metered non-HVAC loads (refrigeration load plus base loads) to be 409.8 kW at 24.8°C. *This agrees with the subtracted value of 409.3 kW to 0.1%*. A proxy for the refrigeration curve C can then be interpolated between the points at 0 and 24.8°C. This curve is given by,

$$C_{\text{proxy}} = 332.164 + 3.13 T \quad (5.6)$$

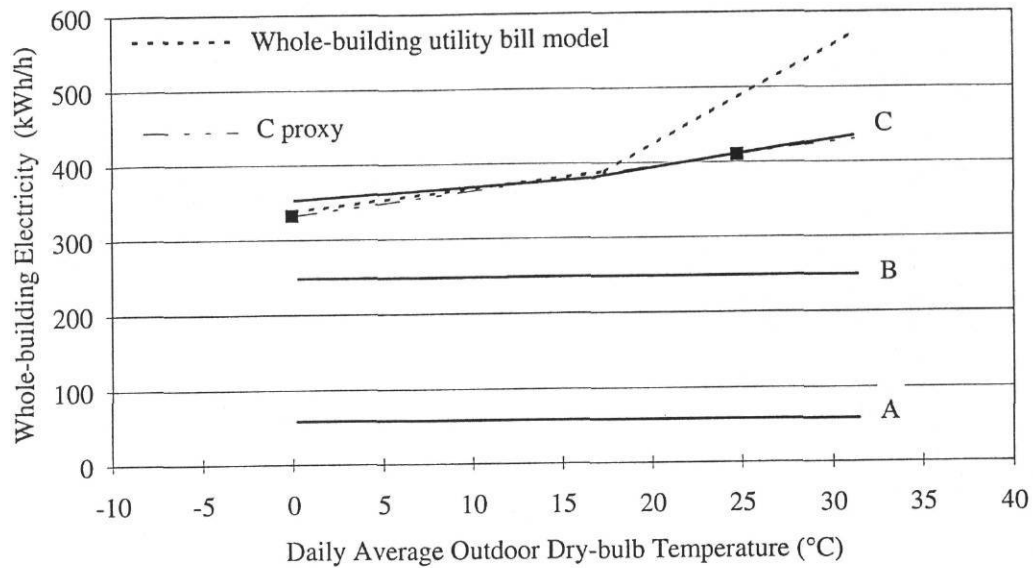
where T is the outdoor temperature.  $C_{\text{proxy}}$  represents the proxy model for the *sum* of the lighting, utility, and refrigeration loads. Proxies for the HVAC and refrigeration models can then be determined by subtraction.

$$E_{\text{HVAC}} = \text{Whole-building utility billing model} - C_{\text{proxy}} \quad (5.7)$$

$$E_{\text{COMP}} = C_{\text{proxy}} - \text{Lighting model} - \text{Utility model} \quad (5.8)$$



**Figure 5.42** *Model disaggregation showing maximum and minimum HVAC loads subtracted from whole-building model for Bryan store.*



**Figure 5.43**

*Model disaggregation showing proxy curve  $C_{proxy}$  for Bryan store. Curve A represents only the miscellaneous utility load. Curve B is the sum of the utility load model and the lighting model. Curve C is the sum of the utility, lighting, and refrigeration compressor models; and curve D is the sum of the utility, lighting, refrigeration compressor, and HVAC models.*

Predictions for HVAC and refrigeration compressor energy use based on these proxy models were compared to the HVAC and refrigeration models developed from the sub-metered data. The results are as follows:

	<b>Data</b>	<b>Proxy Model</b>		<b>4-P CP</b>	
	Mean	R <sup>2</sup>	CV	R <sup>2</sup>	CV
<b>Refrigeration Compressors:</b>	139.5	92%	4%	97%	2%
<b>HVAC:</b>	24.9	11	75	88	28

There are several sources of data from which change-point models can be identified. Sub-metering unquestionably gives the best data. For the case of lighting load, the data vary by less than 10% of the mean. But, unlike the College Station store, the variation in the Bryan store's utility load is more significant -- data may vary to  $\pm 17\%$  of the average. Thus, one-time clamp measurements can give base load data that are within 17% of the average which would be provided by a year's worth of sub-metered data. The effect that this has on the development of the proxy models is seen in the poor R<sup>2</sup> and CV values associated with the proxy HVAC model. Its coefficient of variation is 75% as compared to the 28% of the model identified from sub-metered data. TABLE 5.13 lists the loads of interest in the Bryan grocery store and how the data and models for them were obtained.

Using constant linear models in a load disaggregation procedure works well only when those models accurately represent the data from which they are identified. Because the use of constant base-load models leads to unsatisfactory results when attempting to disaggregate the remaining models, we conclude that there are situations where it is not possible to accurately model component electricity loads without the use of sub-metering. At the very least, multiple clamp-on measurements would be necessary throughout the year to accurately gauge base loads which have significant variation.



TABLE 5.13  
Sources of Model Identification Data for Bryan Store

Load	Where obtained	Comments
Whole-building electricity	monthly utility bills	full year's worth
Miscellaneous utility	site visit	sub-metering, clamp-on watt meter readings, or nameplate data
Lighting	site visit	clamp-on watt meter readings or nameplate
HVAC	site visit	use clamp-on watt meter readings at various temperatures
Refrigeration compressors	site visit	use disaggregation and clamp-on watt measurements at various temperatures

## 5.7 SUMMARY

Some general conclusions about the relative merits of end-use load estimation and sub-metering can be made here:

- 1) Four-parameter change-point models work better than three-parameter or simple linear models when there is a clear change-point in the data, when such a change-point is physically meaningful, and when slopes exist on both sides of the change-point. In general, change-point models are not capable of determining the source of an apparent change-point behavior. As in the case of the College Station store lighting load, some data sets display false change-point behavior. However, they can accurately predict the data when the change-point is present. While change-point models can be used to fit these data sets, they do not represent the data in quality since they use a temperature dependency to describe another relationship such as seasonality. Thus, we must rely on intuition to tell when such cases arise, and may elect to use constant linear models to predict these loads.
- 2) The component energy load models, identified from sub-metered data, were used to predict energy loads from binned degree-hour data. The whole-building bin model annual prediction differed by no more than 4% from either the sub-metered whole-building annual sum or the store's utility billing data.
- 3) A sinusoidal model was found to fit the store's lighting data better than the constant linear model. The sinusoidal model was physically meaningful since the variation in the College Station store's outdoor lighting load was due to the changing length of the day which follows a sinusoidal pattern. The procedure necessary to identify this model was not simple, and were not warranted by the marginal superiority to the constant linear model.
- 4) Utility billing data were found to be good proxies for the *whole-building* sub-metered models. This implies that bin methods can be employed with change-point temperature models developed from utility billing data.
- 5) In the College Station store, base loads were easily discernible through walk-through energy use surveys. This was also true for the Bryan store; however, the sub-metered data (which were used as proxies for clamp-on measurements) were not as cleanly divided according to end-use as in the College Station store. For some loads, it was necessary to know hourly scheduling information. By comparing the nameplate totals to the sub-metered utility energy use, we found

that nameplate data did not accurately represent actual energy use. Since the daily utility and lighting load schedules are fairly constant throughout the year, clamp-on watt-meter readings taken on the distribution panels could have been used to accurately gauge the daily energy use for these end-uses. Some form of sub-metering or multiple clamp-on measurements was required to gauge these loads since lighting and equipment counts only provide peak loads. In the Bryan store, the presence of some temperature- or humidity-dependent loads on the lighting and utility circuits proved to be hindrances in modeling the base loads with only one-time clamp-on measurements and constant linear techniques. A remedy for this would be to actually follow through with the clamp-measurement method to attempt to isolate the HVAC and other temperature-dependent loads which might be on these circuits.

- 6) Attempts at disaggregating whole-building loads have value and limitations. Even monthly whole-building data provide enough information to determine a building change-point model. Without sub-metering, this is the only change-point model available. Component loads which have strong change-point behavior are only discernible through some sort of metering. However, if there is only one such load, then the change-point may be estimated as the change-point of the whole-building load. If there are two such change-point loads, but the variation of one is approximated as linear<sup>17</sup>, then it may be possible to identify models for both loads based on measurements of the minimum and maximum of one. This was how the HVAC and refrigeration loads were disaggregated from the whole-building load at each case-study store.
- 7) Finally, the disaggregation procedure used to determine the HVAC and refrigeration loads without sub-metering depends on all other component loads being fairly constant. This was the case for the College Station store, where one-time clamp-on measurements were fair estimates of the lighting and utility loads. However, these loads at the Bryan store varied much more significantly with temperature, and consequently, the constant linear models identified from one-time measurements made the disaggregation procedure less accurate. The only way to avoid this problem is to make extensive clamp-on measurements in order to aggregate each individual loads into its proper end-use category (refrigeration, HVAC, lighting, or utility). This effort borders on sub-metering,

---

<sup>17</sup> without a change-point. Such is the case for the refrigeration systems of both stores studied here.

since it would have to be done at several times throughout the year for varying loads, and would be quite involved. But even with these limitations, the disaggregation procedure is moderately successful.

- 8) The models identified with sub-metered data for the College Station and Bryan stores were tested with binned degree-hour data. The resulting bin models predicted annual and semiannual energy consumptions to within 5% difference. In most instances, the difference was less than 2%.

## CHAPTER VI

### DISCUSSION AND CONCLUSIONS

#### 6.1 REVIEW OF OBJECTIVES

The literature review of grocery store studies has revealed that identifying potentials for energy savings in food sales facilities is a worth-while pursuit. Because of this, there is a need for further study and modeling of store energy use, and for the evaluation of such models with actual, measured data. The objectives of this thesis were to:

- 1) Conduct a survey of the energy characteristics of grocery stores in the south-Texas area using corporate utility data and information from a mail-in survey.
- 2) Sub-meter hourly component electricity loads at two local case study grocery store along with coincident climatic conditions.
- 3) Develop and test an effective and readily understandable graphical means of presenting the monitored hourly data to store management.
- 3) Test change-point, principle component analysis and multiple linear regression methods to model the daily whole-building and component electricity load data and to evaluate the physical significance and relative merits of PCA and MLR models.
- 4) Compare daily models from the metered data to a model of the monthly utility bill data, and determine the usefulness of the information in the monthly data in predicting component loads.
- 6) Develop and test a new disaggregation technique for determining component-level electricity use based on readily available whole-building electricity use data and survey data, and thereby develop means of gauging energy use that are less-expensive than sub-metering.

## 6.2 CONCLUSIONS

### 6.2.1 93-Grocery Store Survey

The survey of the 93 grocery stores in south-Texas showed that there is much that can be learned about energy use in grocery stores from utility billing data and from simple, mail-in survey that include annual energy use statistics. The survey determined the following:

- 1) Total electricity EUI is as average of about 9 W/ft<sup>2</sup> (96.9 W/m<sup>2</sup>), and varies to extremes by  $\pm 2$  W/ft<sup>2</sup> ( $\pm 21.5$  W/m<sup>2</sup>). Stores smaller than 40,000 ft<sup>2</sup> had an average overall EUI of  $9.5 \pm 1.7$  W/ft<sup>2</sup>, while stores larger than 50,000 ft<sup>2</sup> had an average EUI of  $7.7 \pm 1.1$  W/ft<sup>2</sup>. Stores between 40,000 and 50,000 ft<sup>2</sup> had an average EUI of  $8.2 \pm 1.4$  W/ft<sup>2</sup>.
- 2) With most of the stores in the same geographic area, it seems unlikely that variations in climate-dependent loads explain the trend in EUI. Rather, this seems to be due to component loads which do not increase as store size increases. The largest such load is refrigeration.
- 3) Stores built after 1979 have roughly 9% less energy consumption per square foot than those built before 1979. This is due to at least two reasons.
  - a) Stores built after 1979 were larger. These stores used their additional space to stock merchandise that did not require refrigeration.
  - b) Stores built after 1979 included a significant number of energy-saving measures.
- 4) In the south-Texas region, heat reclamation from the refrigeration systems provides an adequate means of space heating for almost all winter-time conditions.
- 5) In general, grocery store energy use is divisible into components. Because only some of these components are dependent upon store size and/or climate, a more detailed analysis, such as the case study section of this project, is required in order to determine key predictors of energy use for a particular store. Nevertheless, the database section of the project provides a good foundation on which to apply the results of the findings in the case study.

### 6.2.2 Sub-metering of Local Case Study Stores

Hourly component electricity loads were sub-metered at two local case study grocery stores along with coincident climatic conditions. The end-uses of energy were evaluated by means of walk-through surveys as well as intensive sub-metering. The following general conclusions were made:

- 1) The sub-metering of component electricity loads in the case study store proved useful in making the store management aware of operational and maintenance problems. In this study, the feedback was handled manually; however, it is expected that automated methods could have easily provided similar information. Such systems could pay for themselves in just a few years. Problems such as lighting shut-off were spotted quickly through the feedback process.
- 2) Sub-metering also provides good data with which to construct and verify statistical energy end-use models.
- 3) For this study, peak nameplate and survey readings for electricity loads were moderately good proxies for annual sub-metered end-use loads insofar as *relative percentages* of energy use are concerned, though they tend to overstate the effects of food-preparation equipment and other equipment which is used only occasionally or only for a few hours of the day.
- 4) Simple scatter plots of electricity use versus outdoor temperature were useful in gauging the temperature-dependency of certain component loads, and presenting these facts to the store management. They also provided a visual means of comparing the component loads to each other and to whole-building electricity use. Such graphs can be produced each week automatically, and used by store management to spot operations and maintenance problems.
- 5) Daily data were found to be good indicators of the patterns of hourly electricity use in the case study store for all loads except lighting which exhibits strong time-of-day characteristics.

In specific, we note the following:

- 6) The lighting systems of both stores are comparable. The College Station store has 142 kW of indoor lighting, amounting to 2.6 W/ft<sup>2</sup> (28 W/m<sup>2</sup>). The Bryan store has 138 kW of indoor lighting, amounting to 2.8 W/ft<sup>2</sup> (30 W/m<sup>2</sup>).
- 7) In both stores, refrigeration and HVAC loads were found to be dependent on outdoor temperature, while lighting and miscellaneous utility loads were not.

- 8) Both the College Station and Bryan stores have refrigeration and HVAC loads that are temperature-dependent.
- 9) Both stores have change-points in whole-building, HVAC, and refrigeration loads. The refrigeration systems of both stores exhibit a change-point temperature at about 60°F (16°C).
- 10) The College Station store employs heat reclaim from the refrigeration system. As a result, the refrigeration energy use exhibits a bimodal characteristic below the change-point temperature.
- 11) The most significant difference between the two stores is in their HVAC systems. The Bryan store lacks heat reclaim and dehumidification, and uses natural gas for heating.
- 12) The College Station store uses about 851 million Btu/yr, or 15,400 Btu/ft<sup>2</sup>-yr or natural gas whereas the Bryan store uses about 690 million Btu/yr, or 14,200 Btu/ft<sup>2</sup>-yr. Nevertheless, the Bryan store's peak gas use is significantly higher than that of the College Station store due to the fact that it uses gas for space heating.

### 6.2.3 Test of Regression Methods

For this case study, the following conclusions regarding the performance and relative merits of PCA and MLR modeling techniques were drawn:

- 1) The 1992 PCA model worked better than the 1992 MLR model at re-identifying the same model parameters for the 1992 data set as predicted by the 1989 PCA and MLR models. Thus, PCA does better than MLR in terms of parameter re-identification *when used to predict data from a period which was different than that used to construct the model.*
- 2) PCA does slightly better than MLR in terms of R<sup>2</sup> and RMSE criteria *when used to predict data from a period which was not used to construct the model.*
- 3) In both 1989 and 1992 whole-building models, MLR techniques underestimated the effects of solar radiation. For this study, PCA was found to be superior in estimating the effects of the variations in solar radiation on the grocery store whole building electricity use and HVAC system electricity use. The variation in the HVAC load due to solar radiation predicted by the HVAC PCA model was 15.1 kW, which agreed closely with the variation predicted by the diversified load calculation, 14 kW. MLR analysis predicted -5.6 kW.



- 4) In the 1992 models, MLR techniques over estimate the effects of outdoor temperature. For this study, PCA was found to be of greater use than MLR in estimating the effects of variations in temperature on the grocery store whole building electricity use and HVAC system electricity use. The temperature parameter predicted by the HVAC PCA model, 2.34 kWh/h·°C, agreed closely with the building U·A, 2.07 kWh/h·°C. MLR analysis predicted 4.96 kWh/h·°C.
- 5) One shortcoming of both PCA and MLR analyses is that they determine only one base load. They attempt to account for energy use due to *changes* in variables, but cannot estimate the total effect due to any one variable since the base load cannot be separated into contributions due to each variable.
- 6) For some variables, such as specific humidity, identifying the physical significance of the parameters predicted by PCA (or MLR) may be more difficult and involved, since alternative models which must be used to verify the PCA and MLR predictions are likewise complex and involved. For this study, we did not attempt to verify the significance of the specific humidity or sales parameters provided by either PCA or MLR.

In general, we conclude that for a building with a simple HVAC system, model parameters obtained through PCA have more physical significance than those obtained through MLR analysis<sup>1</sup>, and that these model parameters correspond to those which are fairly easily measurable (such as building UA and solar load).

#### 6.2.4 End-use Load Estimation

Some general conclusions about the relative merits of end-use load estimation and sub-metering were made:

- 1) Four-parameter change-point models work better than three-parameter or simple linear models when there is a clear change-point in the data, when such a change-point is physically meaningful, and when slopes exist on both sides of the change-point. In general, change-point models are not capable of determining the source of an apparent change-point behavior. As in the case of the College Station store lighting load, some data sets display false change-point behavior. However, they can accurately predict the data when the change-point is present. While change-point models can be used to fit these data sets, they do not represent the data in

---

<sup>1</sup> This applies to parameters for which physical significance could be tested.

quality since they use a temperature dependency to describe another relationship such as seasonality. Thus, we must rely on intuition to tell when such cases arise, and may elect to use constant linear models to predict these loads.

- 2) The component energy load models, identified from sub-metered data, were used to predict energy loads from binned degree-hour data. The whole-building bin model annual prediction differed by no more than 4% from either the sub-metered whole-building annual sum or the store's utility billing data.
- 3) A sinusoidal model was found to fit the store's lighting data better than the constant linear model. The sinusoidal model was physically meaningful since the variation in the College Station store's outdoor lighting load was due to the changing length of the day which follows a sinusoidal pattern. The procedure necessary to identify this model was not simple, and were not warranted by the marginal superiority to the constant linear model.
- 4) Utility billing data were found to be good proxies for the *whole-building* sub-metered models. This implies that bin methods can be employed with change-point temperature models developed from utility billing data.
- 5) In the College Station store, base loads were easily discernible through walk-through energy use surveys. This was also true for the Bryan store; however, the sub-metered data (which were used as proxies for clamp-on measurements) were not as cleanly divided according to end-use as in the College Station store. For some loads, it was necessary to know hourly scheduling information. By comparing the nameplate totals to the sub-metered utility energy use, we found that nameplate data did not accurately represent actual energy use. Since the daily utility and lighting load schedules are fairly constant throughout the year, clamp-on watt-meter readings taken on the distribution panels could have been used to accurately gauge the daily energy use for these end-uses. Some form of sub-metering or multiple clamp-on measurements was required to gauge these loads since lighting and equipment counts only provide peak loads. In the Bryan store, the presence of some temperature- or humidity-dependent loads on the lighting and utility circuits proved to be hindrances in modeling the base loads with only one-time clamp-on measurements and constant linear techniques. A remedy for this would be to actually follow through with the clamp-measurement method to attempt to isolate the HVAC and other temperature-dependent loads which might be on these circuits.

- 6) Attempts at disaggregating whole-building loads have value and limitations. Even monthly whole-building data provide enough information to determine a building change-point model. Without sub-metering, this is the only change-point model available. Component loads which have strong change-point behavior are only discernible through some sort of metering. However, if there is only one such load, then the change-point may be estimated as the change-point of the whole-building load. If there are two such change-point loads, but the variation of one is approximated as linear<sup>2</sup>, then it may be possible to identify models for both loads based on measurements of the minimum and maximum of one. This was how the HVAC and refrigeration loads were disaggregated from the whole-building load at each case-study store.
- 7) Finally, the disaggregation procedure used to determine the HVAC and refrigeration loads without sub-metering depends on all other component loads being fairly constant. This was the case for the College Station store, where one-time clamp-on measurements were fair estimates of the lighting and utility loads. However, these loads at the Bryan store varied much more significantly with temperature, and consequently, the constant linear models identified from one-time measurements made the disaggregation procedure less accurate. The only way to avoid this problem is to make extensive clamp-on measurements in order to aggregate each individual loads into its proper end-use category (refrigeration, HVAC, lighting, or utility). This effort borders on sub-metering, since it would have to be done at several times throughout the year for varying loads, and would be quite involved. But even with these limitations, the disaggregation procedure is moderately successful.
- 8) The models identified with sub-metered data for the College Station and Bryan stores were tested with binned degree-hour data. The resulting bin models predicted annual and semiannual energy consumptions to within 5% difference. In most instances, the difference was less than 2%.

---

<sup>2</sup> without a change-point. Such is the case for the refrigeration systems of both stores studied here.

## REFERENCES

- Adams, P., Jr. 1985. "Intereffects in supermarkets", ASHRAE Journal. Oct. 1985, pp. 38-40.
- Adams, P., Jr. 1992. "Merchandising vs. energy consumption in the supermarket", ASHRAE Journal. Apr. 1992, pp. 53-58. AIR 1992. AIR: Software for Calculating Psychrometric Properties, S. Katipamula, R. Sparks, J. Spadaro, Energy Systems Laboratory, Texas A&M University, (January).
- COLROW3D 1991. COLROW3D: Software for creating 3-D plots, J. Matson, R. Sparks, J. Spadaro, J. Haberl, Energy Systems Laboratory, Texas A&M University, (October).
- Chen, L. 1991. Developing a Change-point Principal Component Predictive Model for Energy Use in a Supermarket, Master's Thesis, Department of Mechanical Engineering, Texas A&M University (May).
- Cox, R.L., D.E. Claridge, J.S. Haberl. 1992. "Survey of Energy Use in Grocery Stores", Proceedings of the Eighth Symposium on Improving Building Systems in Hot and Humid Climates, Energy Systems Laboratory, Texas A&M University (May).
- Daultrey, S. 1976. "Concepts and Techniques in Modern Geography No. 8: Principal Component Analysis", Geo Abstracts Limited, University College Dublin, Norwich.
- DOE. 1981. Research and development of highly energy-efficient supermarket refrigeration systems by William Toscano et al., Vol 1 Department of Energy, ORNL/sub/80-60601/1 (Oct.).
- Draper, N.; H. Smith. 1981. Applied Regression Analysis. Second Edition, John Wiley and Sons, New York.
- Dubin, F.S.; C.G. Long. 1978. Energy Conservation Standards. New York: McGraw-Hill.
- EIA. 1986 "Commercial Buildings Consumption and Expenditures 1986", Energy Information Administration Report DOE/EIA-0318(86), Washington, DC.
- FEA. 1977. Guide to Energy Conservation for Grocery Stores, Federal Energy Administration FEA/D-76/096 (Jan.).

- Fels, M.F., ed. 1986. "PRISM: An Introduction", Energy and Buildings, Vol. 9, pp. 5-18.
- Feuermann, D., Kempton, W. 1987, "ARCHIVE: Software for the Management of Field Data", Center for Energy and Environmental Studies Report No.216, (This also includes Tony's Tools, and Art's Tools which are useful columnar data processing tools), Princeton University.
- FSF 1989. GAWK, Free Software Foundation (PC version of the Unix-based AWK tool kit), 675 Massachusetts Ave., Cambridge, Massachusetts 02139.
- GE, 1986. Ballast Technical Guide. General Electric Company, Cleveland, OH 44112. pp. 16-17.
- Golden, 1990. GRAPHER and Surfer, Golden Software, 809 14th Street, P.O. Box 281, Golden, Colorado, 80402-0281.
- Greenspan, L. 1977. "Humidity Fixed Points of Binary Saturated Aqueous Solutions" Journal of Research of the National Bureau of Standards - A. Physics and Chemistry. Vol. 81A, No. 1, Jan.-Feb.
- Haberl, J.S.; D.E. Claridge; D.T. Harrje. 1990. "The design of field experiments and demonstrations". Proceedings of the IEA Field Monitoring Workshop, Gothenburg, Sweden (Apr.).
- Golden 1990. GRAPHER and Surfer, Golden Software, 809 14th Street, P.O. Box 281, Golden, Colorado, 80402-0281.
- Hadley, N.; S. Tomich. 1986. "Multivariate statistical assessment of meteorological influences on residential space heating", Proceedings of ACEEE 1986 Summer Study on Energy Efficiency in buildings. Washington, D.C., (July)
- Henry, R.C.; G.M. Hidy. 1979. "Multivariate analysis of particulate sulfate and other air quality variables by principal components-I. annual data from Los Angeles and New York". Atmospheric Environment. Vol 16. pp. 929-942.
- Hill, J.M.; A.S. Lau. 1993. "Performance of supermarket air-conditioning systems equipped with heat pipe heat exchangers", ASHRAE Transactions. Vol 99, Part 1.
- Howell, R.H. 1993. "Effects of store relative humidity on refrigerated display case performance", ASHRAE Transactions. Vol 99, Part 1.
- Intex 1990. 3-D Graphics, Intex Solutions, 161 Highland Ave., Needham, Massachusetts 02194 (requires Lotus 123).

- Jolliffe, I.T. 1986. Principal Component Analysis. Springer-Verlag, New York.
- Khattar, M.K. 1991. "Supermarket air-conditioning and dehumidification", EPRI Journal. Sep. 1991, pp. 44-46.
- Khattar, M.K.; M.H. Blatt; D.H. Walker. 1991. "Modeling supermarket refrigeration energy use and demand", ASHRAE Journal. Jul. 1991, pp. 23,26,28-31.
- Knebel, D.E. 1983. Simplified Energy Analysis Using the Modified Bin Method, pp.2-1 to 3-68, Atlanta: American Society of Heating, Refrigeration, and Air-conditioning Engineers, Inc.
- Lotus 1985, Lotus 1-2-3 Spreadsheet, Lotus Development Corp., 55 Cambridge Parkway, Cambridge, Massachusetts 02142.
- MacDonald, M.; D. Wasserman. 1988 "Investigation of metered data analysis methods for commercial and related buildings:, Oak Ridge National Laboratory Report ORNL/CON-279. (May).
- Rao, C.R. 1964. "The use and interpretation of principal component analysis in applied research", Sankhya A. Vol. 26, pp. 329-358.
- Reddy, T.A.; D.E. Claridge. 1993. "Using synthetic data to evaluate multiple regression and principal component analyses for statistical modeling of building energy consumption". Energy Systems Laboratory, Texas A&M University. Paper to be submitted to the Journal of Solar Energy Engineering.
- Ruch, D.K.; L. Chen; J.S. Haberl; D.E. Claridge. 1991. "A Change-Point Principle Component Analysis (CP/PCA) Method for Predicting Energy Usage in Commercial Buildings: The PCA Model", Proceedings of the 1991 ASME-JSES-JSME International Solar Energy Conference. Reno, Nevada (Mar.), pp. 441-448.
- Ruch, D.K.; D.E. Claridge. 1991. "A Four-Parameter Change-Point Model for Predicting Energy Consumption in Commercial Buildings", Proceedings of the 1991 ASME-JSES-JSME International Solar Energy Conference. Reno, Nevada (Mar.), pp. 433-439.
- SAS Institute Inc. 1989, Statistical Analysis System. SAS Institute, Cary, NC.
- Schrock, D.W; D.E. Claridge, D.E. 1989. "Predicting energy usage in a supermarket", Proceedings of the Sixth Annual Symposium on Improving Building Systems in Hot and Humid Climates, Texas A&M University (Oct.).

- Schrock, D.W. 1989. Predicting Energy Usage in a Supermarket, Master's Thesis, Department of Mechanical Engineering, Texas A&M University.
- Synergistic. 1990. Software, Installation, and Technical Specifications for the Model C180 Survey Meter/Recorder, 5725 Bundy Rd., New Orleans, LA 70127.
- Turner, W.C., ed. 1982. Energy Management Handbook John Wiley and Sons, New York, p. 332.
- Vaisala. 1988. Vaisala Sensor Systems. PL 26, SF-00421, Helsinki, Finland.  
Phone +358 0 894 91. Model No. HMD 20 UB-0021901.1.
- Wong, V.T. 1988. "Case study of a commercial conservation retrofit: Measured results from a grocery store", ASHRAE Transactions, Vol. 94, Part 2.



## APPENDIX A

### DATA PROCESSING

This appendix describes the basic procedures used to poll and archive data from the College Station and Bryan grocery stores. Portions of this work are adapted from Haberl, et al. (1992) which contains a wealth of background information about building sub-metering projects in general.

#### A.1 REVIEW OF MEASUREMENT TECHNIQUES

This section provides a review of measurement techniques used at the case study stores, including how electricity measurements, temperature measurements, and humidity measurements were taken. Component electricity loads for both the Bryan and College Station stores were measured with voltage (potential) and current transducers and recorded on separate data acquisition systems. Indoor temperature and relative humidity measurements for the College Station store were measured with sensors located near the air-handler units' return air grille and were also recorded with the data acquisition systems. Outdoor climate data -- dry-bulb temperature, relative humidity, solar radiation, and wind speed -- were measured with sensors located atop the Zachry Engineering Center located in between the two stores approximately two miles from each, and were provided by the Texas LoanSTAR monitoring program.

##### A.1.1 Basics of Electricity Monitoring.

In the case study stores, hourly electricity use was recorded using digital watt transducers. These make use of the Watt/Watt-hour transducer. This solid state device provides a direct analog or digital output signal that is proportional to the energy being consumed. Watts are calculated electronically and output as either an analog DC signal or pulsed output that uses a basic time-division-multiplier principle. Almost all of the kW channels at both stores receive analog output. The only exception is the digital whole-building signal at the Bryan store. Conversion of the energy consumption to analog or pulsed output utilizes two different processes. In brief, an input reference voltage from a potential transformer (PT) is supplied that provides a signal that is proportional to the voltages of each of the phases being monitored. This is combined within the data



acquisition hardware with input current signals -- from current transducers (CTs) attached to the wires of each monitored circuit-- to produce digital output signals that are proportional to the energy used by each circuit being monitored. These signals are then stored by the data acquisition system for later retrieval.

### **A.1.2 Measuring Temperature**

The measurement of temperature by a computer is a rather mature technology. In fact, the computerized measurement of temperature has become so reliable that it is quite often used as an indirect method for measuring other quantities such as flow and humidity. The temperature sensor used at the College Station store is a 2-wire, 1000-Ohm, Platinum resistance temperature detector (RTD).

An RTD is an electrical device which has a resistance that varies linearly with temperature. It can be used, therefore, to measure temperature. Electrical resistance in many materials changes with temperature. In some materials this change is very reproducible and therefore can be used as an accurate measure of the temperature.

### **A.1.3 Measuring Humidity**

This section describes the humidity-sensing devices in the College Station store (there are none in the Bryan store).

**Resistance-type Humidity Measurements.** The remote humidity sensor used by its HVAC system is known as a resistance-type humidity sensor. The electrical conductivity of certain hygroscopic materials varies in proportion to the amount of moisture absorbed by the material. In certain materials this occurs in a repeatable fashion and can be used to measure the relative humidity of the surrounding air. One of these sensors, known as a Pope cell-type sensor, utilizes a thin layer of sulfonated polystyrene which has been placed on an insoluble surface. An electrically conductive layer is then bonded to the resin and electrodes are attached to facilitate the measurement of the difference in electrical resistance. Such a device exhibits a non-linear change in resistance as moisture is absorbed by the hygroscopic resin, varying from a few megohms to about 1,000 ohms at 100% saturation.

**Thin-film Capacitance-type Humidity Measurements.** Humidity measurements were taken at the College Station store to help determine how well the store's humidity was controlled by the HVAC system. Figure A.1 shows the return air temperature and humidity sensors used at the College Station store. The return air humidity sensor installed at the College Station store is a thin-film polymer humidity sensor manufactured by Vaisala Sensor Systems (Vaisala 1988). It uses a polymer to absorb and desorb moisture. The polymer is usually mounted between a rigid aluminum base and another electrode (usually a thin gold film). The polymer exhibits a change in capacitance with a change in absorbed moisture. In one type of sensor, this changing capacitance changes the frequency of an oscillating circuit which in turn is changed into a varying voltage or current that is proportional to the moisture present. The return air humidity sensor was tested with a two-salt solution calibration and found to agree with theoretical RH values to 6.3%. The RH calibration results are listed in Table A.1. The salt solutions used in the calibration were NaCl (for 75%RH) and LiCl (for 11%RH). The theoretical equations for the relative humidity of the air above the surface of these solutions are as follows (Greenspan 1977).

**Lithium Chloride:**

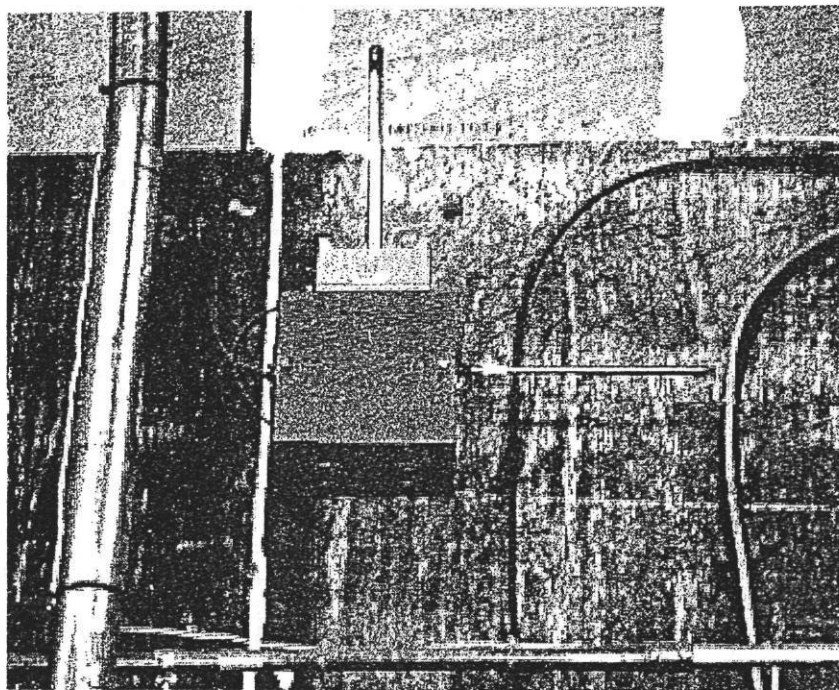
$$\text{RH} = 11.2323 - 0.00824245 T - 0.000214890 T^2$$

**Sodium Chloride:**

$$\text{RH} = 75.5164 + 0.0398321 T - 0.00265495 T^2 + 0.000284800 T^3$$

where T is the temperature of the air and solution at thermal equilibrium.

The RTD sensor was tested against a transfer reference RTD sensor which agrees with ASTM thermometers to 1%. The test RTD agreed with the transfer standard RTD to 6% accuracy.



*Figure A.1* Photograph of the temperature/humidity sensor installed at the College Station store.

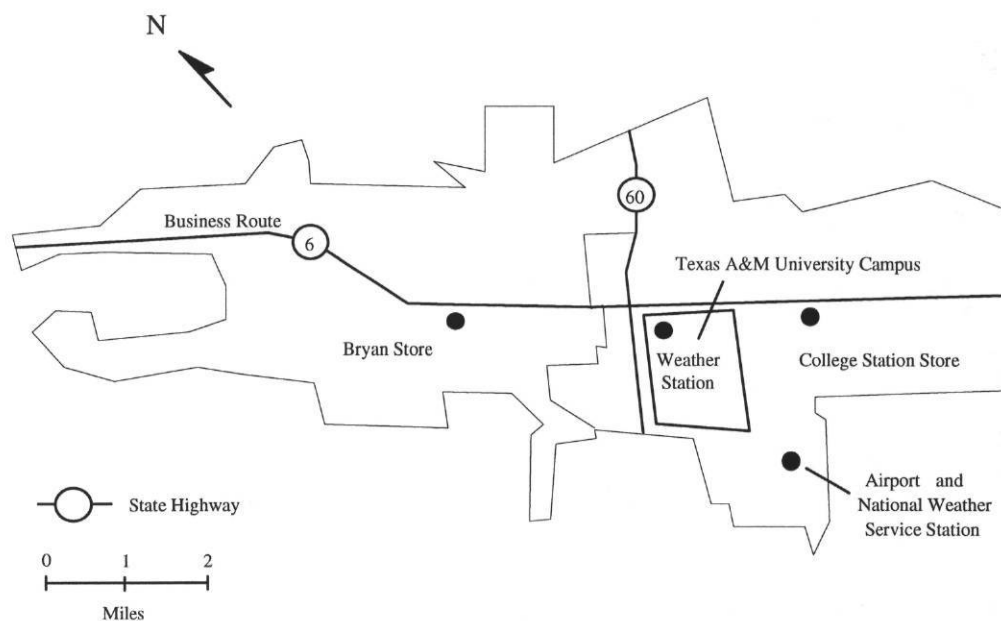
TABLE A.1  
Results of the Calibration of Vaisala Humidity Sensor

Steady State Conditions				
Salt Used	Avg. T	Avg. Test RH	Avg. Theoretical RH	Difference
NaCl	62.1°F	75.25%RH	76.13%RH	0.84%RH
NaCl	72.5°F	73.09%RH	76.3%RH	3.2%RH
NaCl	82.4°F	71.73%RH	76.56%RH	4.8%RH
LiCl	61.1°F	10.39%RH	11.09%RH	0.70%RH
LiCl	70.3°F	10.54%RH	11.04%RH	0.50%RH
LiCl	80.7°F	10.54%RH	10.99%RH	0.45%RH

## A.2 MONITORING EXPERIMENTS USED IN THE CASE STUDY STORES

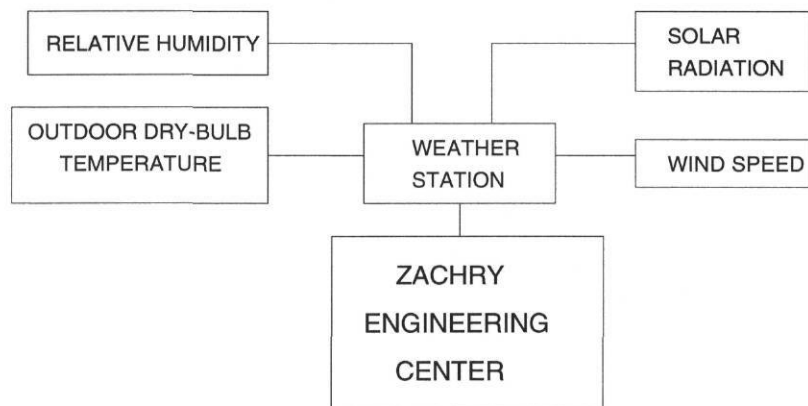
Two sites were used in the case study -- the College Station and Bryan grocery stores. Weather data was obtained from a nearby weather station located on top of the Zachry Engineering Center on the campus of Texas A&M University, approximately half-way between the two stores. Figure A.2 shows a map of the cities of College Station and Bryan including the locations of the case study stores and weather station.

The level of monitoring used in the case study stores enabled a more detailed analysis for identifying the building energy use characteristics and for pinpointing building operational problems. Figure A.3 shows the weather station monitoring diagram. The weather station was located approximately two miles from either grocery store, atop the Zachry Engineering Center at Texas A&M University. The weather station provided data which include outdoor ambient dry-bulb temperature, outdoor relative humidity, horizontal solar radiation, and wind speed. Other psychrometric properties of outdoor air were derived using psychrometric relationships coded in to a computer processing routine developed



**Figure A.2**

*Map of Bryan-College Station area showing store locations.*



**Figure A.3** *Monitoring Diagram for Weather Station*

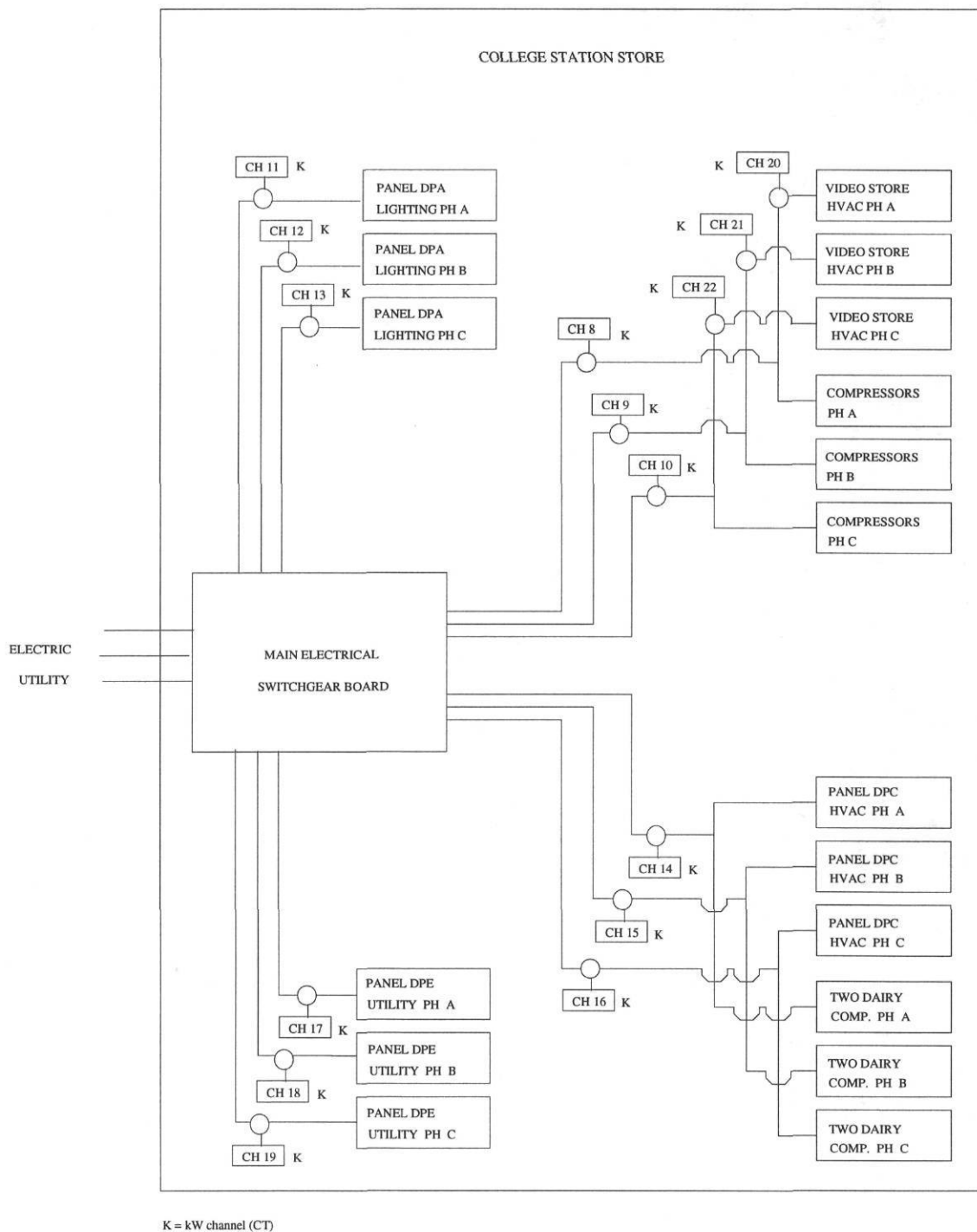


Figure A.4

kWh Monitoring Diagram for College Station Store, Site 901

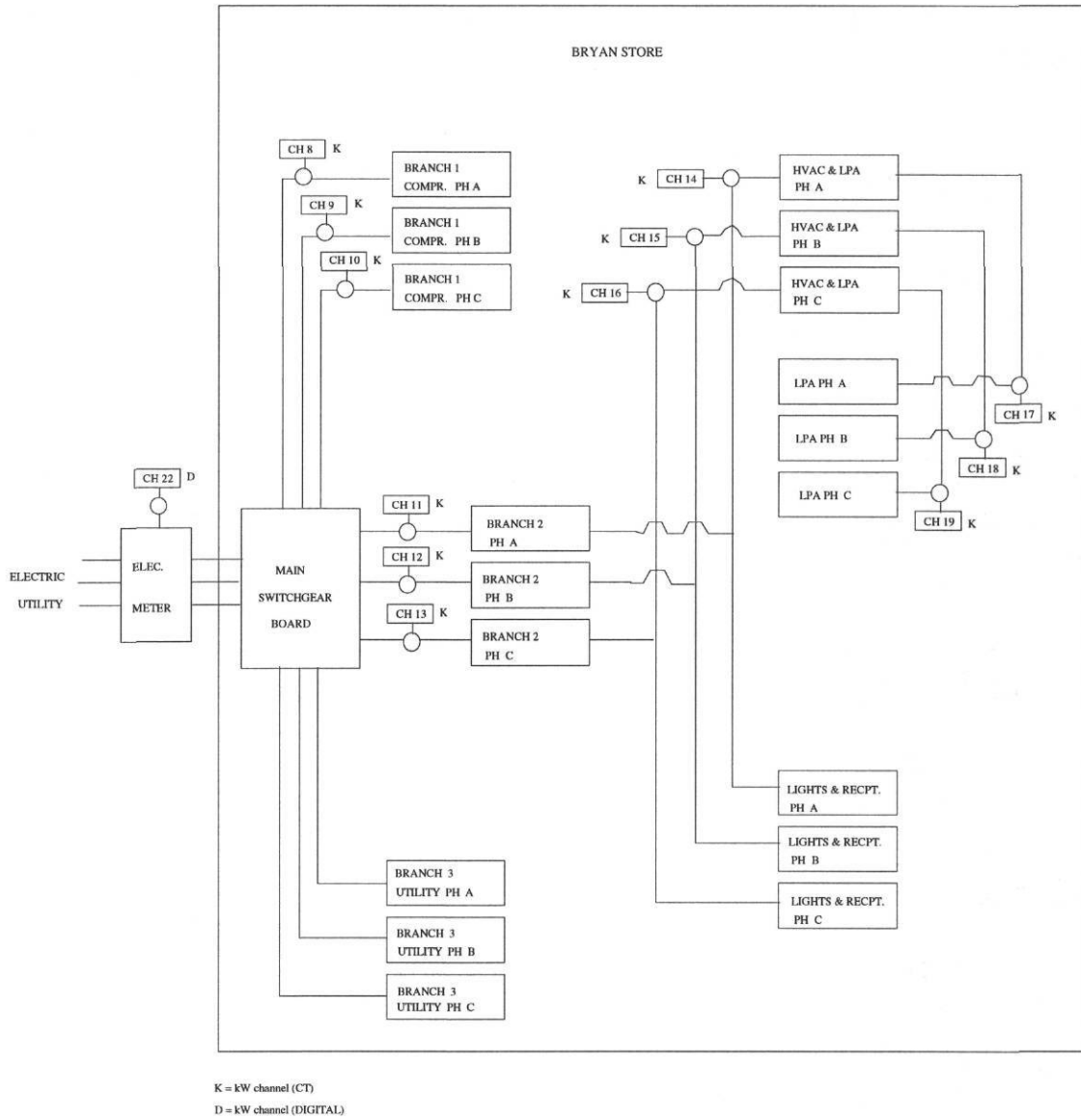


Figure A.5

kWh Monitoring Diagram for Bryan Store, Site 913

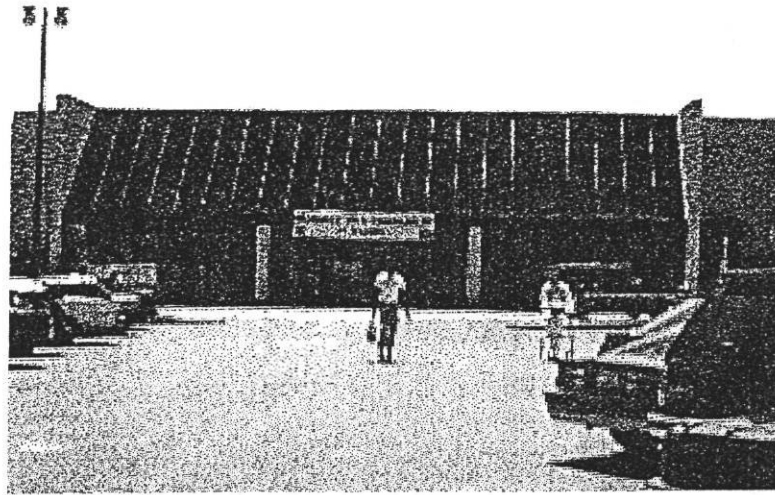


Figure A.6 Photograph of the front of the College Station store



Figure A.7 Photograph of the front of the Bryan store.



by the staff of the Energy Systems Laboratory at Texas A&M University (AIR 1992). Figure A.4 and Figure A.5 show the monitoring experiment plans as installed in the College Station and Bryan case-study stores, respectively. Figure A.6 and Figure A.7 are photographs of the fronts of the College Station and Bryan stores. The electrical connections to the loggers are illustrated in Figure A.8 and Figure A.9. The loggers have been configured to record the following:

**College Station Logger.**

- fifteen channels of electrical power, kW (CT Channel 0, 1, 2 ... 14),
- one channel of temperature, 1000 Ohm RTD (AN Channel 10),
- one channel of relative humidity, 4-20 mA (AN Channel 11)

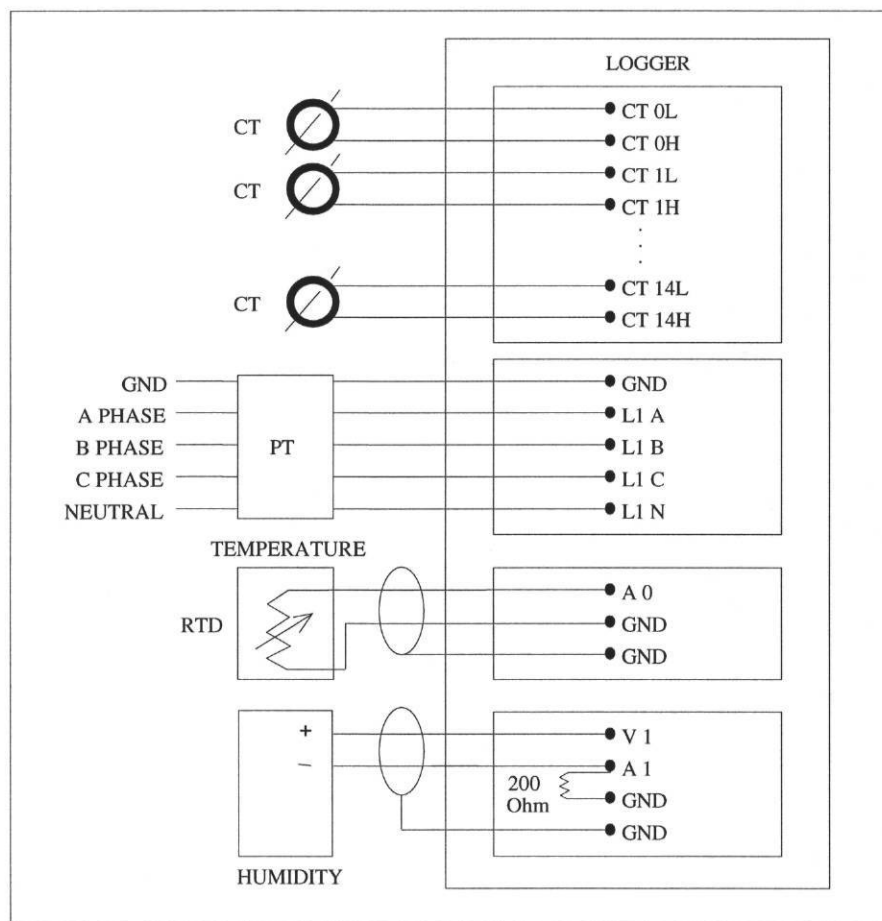
**Bryan Logger.**

- twelve channels of electrical power, kW (CT Channel 0, 1, 2 ... 11),
- one channel of whole-building electrical power, kW (D Channel 0)

Fifteen separate channels are recorded for the College Station site. When the monitoring was installed, an attempt was made to isolate each of the four major electrical loads -- refrigeration compressors, lighting, HVAC, and miscellaneous loads. Three channels were designated for each load (for each electrical phase). However, because part<sup>1</sup> of the video store's HVAC system was installed on the whole-building refrigeration circuit, three additional sub-metering channels were added to monitor the video store HVAC load so that it could be subtracted from the main store refrigeration load. In late 1991, it was discovered that the store management had subsequently installed two additional 7.5-horsepower dairy refrigeration compressors on the main store's HVAC circuit. These were discovered too late to install more sub-metering. Walk-through survey measurements revealed that the two new dairy compressors amount to about 9% of the remaining refrigeration compressor load. Thus, during subsequent statistical analysis, this fraction was used to adjust the data when necessary to accurately gauge the refrigeration and HVAC loads. For the College Station store, whole-building electricity data are not monitored directly, but assembled by adding the data from the first twelve sub-metered channels.

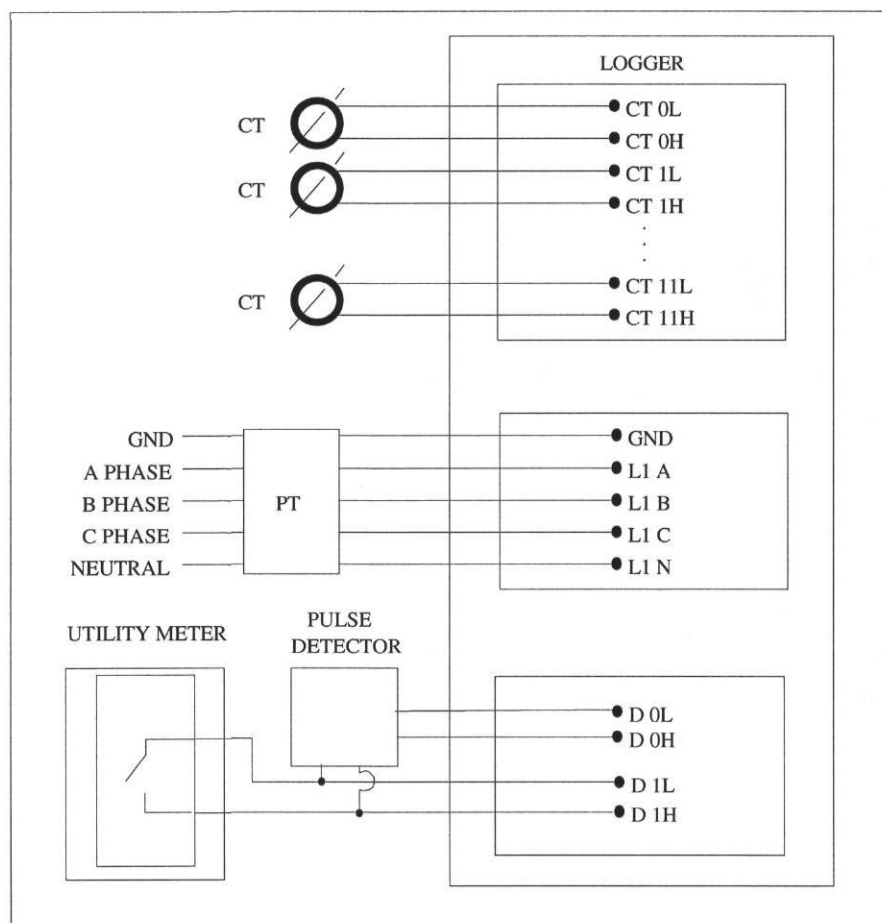
---

<sup>1</sup> Two 7.5-ton roof-top units.



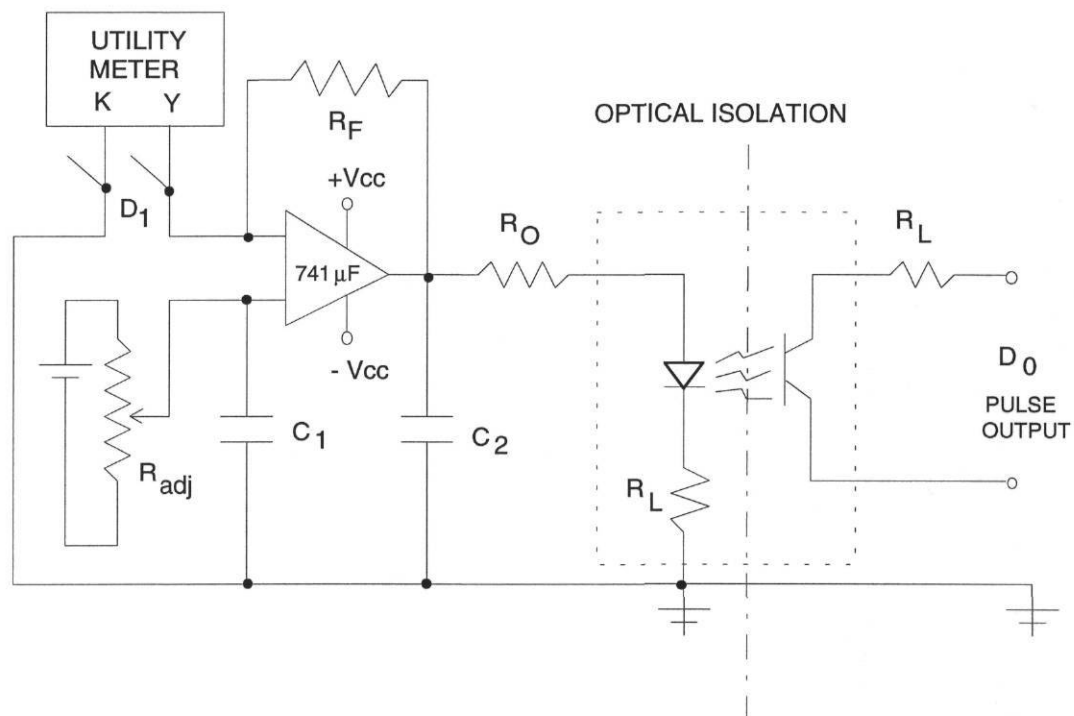
**Figure A.8**

*Diagram of College Station logger set-up.*



**Figure A.9**

*Diagram of Bryan logger set-up.*



**Figure A.10**

*Pulse Detector Circuit.*

*This optical isolation circuit was added between the utility meter and the logger to provide a clear pulse signal. The logger digital channel 1 is used as a bias for the input signal conditioning, but does not record any data. Digital channel 0 is used to record the pulse output.*

Figure A.5 shows the monitoring experiment plan as installed in the Bryan case study store. The Bryan monitoring scheme is made up of thirteen separate data channels. While the ultimate goal was to monitor the four major components of the whole-building load, these loads could not be gauged directly. Instead, a cascading scheme of sub-metering was used. The first three data channels measure the three phases of the refrigeration compressor load. The next three measure the three phases comprising lighting and HVAC. The next three channels measure the HVAC and some lighting loads. The next three channels measure the lighting load contained in the previous three channels. Subtraction is then used in the data processing routines to isolate the total lighting load from the HVAC load. The last data channel monitors whole-building electricity use. This is in the form of a digital pulse signal provided by the electric utility. Figure A.10 shows a pulse detector circuit which was installed between the logger terminals and the electric meter output terminals. This was done to ensure that the voltage pulse generated by the utility meter was detected and electrically isolated from the logger. The remaining miscellaneous store loads are identified by subtracting the sum of all the sub-metered loads from the whole-building energy consumption.

The whole-building data recorded for both stores compares to that given by the monthly utility bills as follows in Table A.2. Values of monthly electricity consumption for the College Station store differ by less than 3%, and those for the Bryan store by less than 1%. The strong agreement for the Bryan store data is not surprising since it represents the same signal that the utility company uses for billing.

### **A.3 USING A DATA LOGGER**

This section that follows is intended to document how the energy and space condition data for both grocery stores were collected, stored, and retrieved. The loggers used at the grocery stores are of the same model and were developed by Battelle/PNL for the USDOE. This model is commercially available (Synergistics 1990). The reader is referred to the manufacturer's manual for additional details.

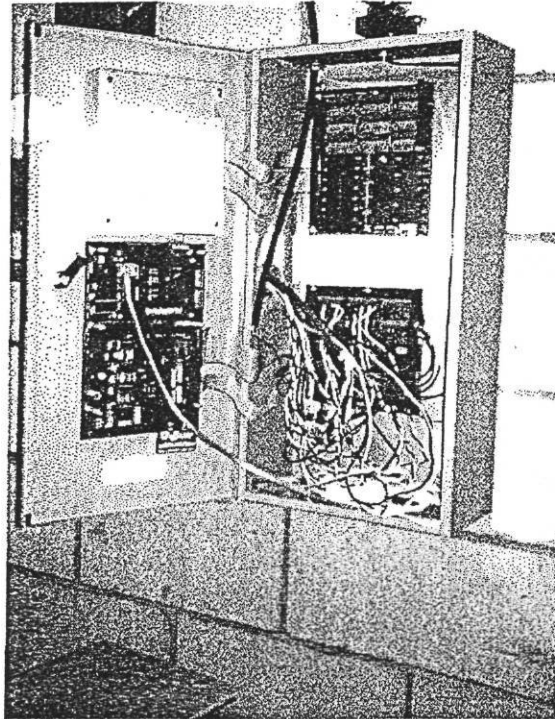
TABLE A.2  
Monthly Utility Bills and Sub-metered Whole-building Data

Date	Store	Sub-metering (kWh/month)	Utility bills (kWh/month)	Difference (%)
1/9/92-2/7/92	C.S.	236376	240400	1.7
2/7/92-3/11/92	C.S.	286223	292800	2.2
3/11/92-4/8/92	C.S.	243524	247600	1.6
4/8/92-5/12/92	C.S.	328130	334000	1.8
5/12/92-6/10/92	C.S.	288210	294000	2.0
6/10/92-7/12/92	C.S.	333525	339200	1.8
7/12/92-8/11/92	C.S.	357072	363600	1.8
8/11/92-9/11/92	C.S.	341525	347200	1.6
9/11/92-10/9/92	C.S.	285100	292400	2.5
10/9/92-11/9/92	C.S.	291172	296400	1.8
12/3/92-1/28/93	Bryan	256874	257680	0.3
1/28/93-2/25/93	Bryan	251759	250400	-0.5
2/25/93-3/29/93	Bryan	299630	299520	-0.03
3/29/93-4/30/93	Bryan	316664	314320	-0.7

### A.3.1 Connecting the Sensors to the Logger

Figure A.11 is a photograph of the data logger installed at the College Station store. Figure A.8 and Figure A.9 are diagrams of the logger setups at both stores. The following sections detail the connections made to each logger from the electricity and thermal loads being monitored.

**Connecting a Digital Pulse Signal.** A digital pulse signal is used at the Bryan store in order to monitor whole-building electricity. The on/off pulse signal was provided by a 2-wire KYZ pulse. Only the KY terminals were monitored by the data logger. For every pulse counted, 0.288 kiloWatt-hours were recorded. This constant was provided by Bryan Utilities which provided the signal from the meter. This figure was verified by comparing recorded monthly whole-building data to the monthly utility bills; monthly totals differed by less than 1%.



*Figure A.11*      *Photograph of connection of the logger at the Bryan store*

**Connecting a 2-Wire Resistive RTD Signal.** A resistive RTD is used at the College Station store to monitor return air temperature from a temperature sensor. The RTD was connected directly to the logger without the need of a header module by approximately 50 feet of 2-conductor, 22 AWG shielded cable. The shield wire was grounded to the logger to avoid a ground loop.

**Connecting a 2-Wire, 4-20 mA Signal with the Use of a 200-Ohm Resistive Header.** At the College Station store, a 4 to 20 mA signal is used to monitor return air relative humidity. Connecting a 4-20 mA current loop to the logger required that a resistive header be inserted into the logger circuit board for this channel. The header module provides a 200-Ohm resistor across the A1 to GND terminals. This converted the 4 to 20 mA signal to a 0.8 to 4 V signal. Software options in the polling procedure are used to calculate relative humidity from the signal provided to the logger. The relative humidity was found by multiplying the signal voltage by 31.25, and subtracting 25 (calibration constants provided by the manufacturer). Thus, a sensor signal of 2.4 V translates to a reading of 50% relative humidity.

**Connecting Multiple CTs Using a Summing Module to One Power Channel.** Electrical power, voltage, current, and power factor were measured at both case study stores by the on-board solid state Watt/Watt-hour transducers. The primary input(s) that were needed were properly sized, shunted current transformers (CTs) and a potential (voltage) transformer (PT). CTs were field-checked with hand-held "clamp-on" ammeter. All CTs were installed with the same polarity. This was accomplished by aligning the arrows marked on the CTs themselves toward the electrical source.

**Connecting the PT to Provide a Voltage Signal.** In order to provide the power measurements, one potential transducer per store was connected to each 3-phase feed being monitored. The loggers used in both case study stores provided PT inputs for two 3-phase feeds -- only one input was used. Care was taken to align the A, B, and C phases with their respective CTs both on the termination board and in software (this is the single most common mistake that is made with any logger -- incorrect configuration of power monitoring). At the College Station store, when the video store HVAC monitoring was installed, an error in the labeling of electrical wiring was discovered. The phases were labeled incorrectly by the electrician who installed them. As a result, phasing of the monitoring was changed to match the wiring.



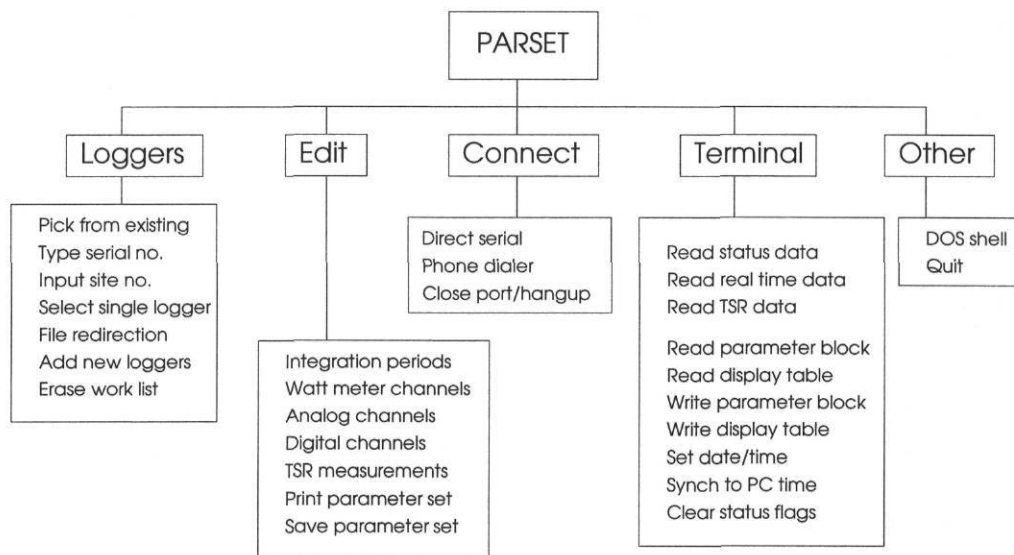
### **A.3.2 Survival Commands for Programming the College Station and Bryan Loggers.**

Data from the stores were originally collected with SYNERNET software provided by the logger manufacturer. Eventually, these stores were polled with an automatic procedure to facilitate uniform data storage for data used by the LoanSTAR program.

The SYNERNET software that was provided by the manufacturer with each logger is a reasonably powerful polling software package. The section that follows provides a summary of the commands used to poll the loggers used in the case study stores. In each example, enough details are provided to illustrate the basic steps that are necessary for polling a site. As such, only those SYNERNET commands that are necessary to accomplish this are discussed.

**SYNERNET.** SYNERNET is the menu-driven software that was provided by the manufacturer to schedule and poll a logger. It contains five sub-programs that can be used to perform the different functions. Each of the sub-programs can be executed separately by typing the executable name (i.e., PARSET <enter>) to execute directly or by beginning a session with SYNERNET and working ones way down the menu tree. SYNERNET always begins a session by checking the PC's time and date.

**PARSET.** PARSET is the workhorse of the SYNERNET software system and was the only interface used for accessing the data acquisition systems for the Bryan and College Station stores. PARSET was used to add a logger to the network, configure channels in the logger, manually poll the logger, view real-time data, and download data to a PC. Figure A.12 illustrates the menu arrangement



**FIGURE A.12** *Diagram for the PARSET program.*

within PARSET. For the most part, one must always choose a logger, then either edit the channels, or (if this has not already been accomplished) connect to a site, and use the terminal command to communicate to the logger after connecting.

### A.3.3 Setting Up and Polling a Logger.

This section discusses how the data acquisition systems were set up, accessed, and how data were downloaded. The College Station store logger is used as an example to illustrate the steps. This next section walks the reader through how the loggers used in the case studies were set up and configured, and what the data look like coming from the logger. Except where distinction is necessary, the examples will pertain to the College Station logger only.

Any new logger that is added to a SYNERNET network needs to be set up with the PARSET program. In the case study stores, C-180 loggers connected to the PC via a modem were used. These College Station logger was set up with the following menu commands:

```
SYNERNET
PARSET
  LOGGER(S)
    ADD NEW LOGGERS
      HOW MANY NEW LOGGERS TO ADD TO THE NETWORK: (1)
      INPUT SITE NUMBER: (901)
      INPUT LOGGER LETTER:(A)
      INPUT LOGGER SERIAL NUMBER:(####)
      INPUT PARAMETER SET CODE:(A)
```

This results in the following logger "901/A/####/A" being added. This logger can be reselected anytime by calling-up:

```
PICK FROM EXISTING LOGGERS
  901/A/####/A
```

Next, the logger needs to be configured so that it is recording the necessary information. This is accomplished with PARSET as follows:

```

SYNERNET
PARSET
  LOGGER(S)
    PICK FROM EXISTING LOGGERS
      901/A/####/A
  EDIT
    INTEGRATION PERIODS
      UNIFORM INTEGRATION PERIOD EDITOR

```

Table A.3 is shows the integration periods for logger 901/A/####/A (College Station store). In general we see that hourly data are being sampled and captured to memory. Table A.4 is shows the integration periods for logger 913/A/####/F (Bryan store).

Next, the Watt meter channels are set up with

```

EDIT
  WATT METER CHANNELS

```

The results of the session are shown in Table A.5 and Table A.6. It should be noted that in Table A.5, the Hi/Lo polarity of the CT channels 4, 5, and 14 have been reversed. This was done to compensate for improperly installed polarity on the CTs. Alternatively, the CT wire terminations in the logger box could have been switched pair-by-pair. One may also notice that the channel labeled "Video AC



TABLE A.5  
Configuration Table for College Station Logger Showing Watt Channels.

----- WATT CHANNELS -----										
Chan	Description	Search String	STA	Hi	Lo	VMult	Amps	V	C	PR P A
CT 0	COMPS-PHASE A		ON	A1	N1	1	600			0 *
CT 1	COMPS-PHASE B		ON	B1	N1	1	600			1 *
CT 2	COMPS-PHASE C		ON	C1	N1	1	600			2 *
CT 3	PNL DPA-PHASE A		ON	A1	N1	1	1200			3 *
CT 4	PNL DPA-PHASE B		ON	N1	B1	1	1200			4 *
CT 5	PNL DPA-PHASE C		ON	N1	C1	1	1200			5 *
CT 6	PNL DPC-PHASE A		ON	A1	N1	1	1200			6 *
CT 7	PNL DPC-PHASE B		ON	B1	N1	1	1200			7 *
CT 8	PNL DPC-PHASE C		ON	C1	N1	1	1200			8 *
CT 9	PNL DPE-PHASE A		ON	A1	N1	1	600			9 *
CT10	PNL DPE-PHASE B		ON	B1	N1	1	600			10 *
CT11	PNL DPE-PHASE C		ON	C1	N1	1	600			11 *
CT12	VIDEO AC PHASE A		ON	C1	N1	1	100			12 *
CT13	VIDEO AC PHASE B		ON	B1	N1	1	100			13 *
CT14	VIDEO AC PHASE C		ON	N1	A1	1	100			14 *
CT15	NOT USED		OFF	A1	N1	1	100			15

TABLE A.6  
Configuration Table for Bryan Logger Showing Watt Channels.

----- WATT CHANNELS -----										
Chan	Description	Search String	STA	Hi	Lo	VMult	Amps	V	C	PR P A
CT 0	COMPRESSORS PH 1		ON	A1	N1	1	600			0 *
CT 1	COMPRESSORS PH 2		ON	B1	N1	1	600			1 *
CT 2	COMPRESSORS PH 3		ON	C1	N1	1	600			2 *
CT 3	MAIN BRANCH PH 1		ON	A1	N1	1	1500			3 *
CT 4	MAIN BRANCH PH 2		ON	B1	N1	1	1500			4 *
CT 5	MAIN BRANCH PH 3		ON	C1	N1	1	1500			5 *
CT 6	AC & LPA PH 1		ON	A1	N1	1	1000			6 *
CT 7	AC & LPA PH 2		ON	B1	N1	1	1000			7 *
CT 8	AC & LPA PH 3		ON	C1	N1	1	1000			8 *
CT 9	LPA PH 1		ON	A1	N1	1	100			9 *
CT10	LPA PH 2		ON	B1	N1	1	100			10 *
CT11	LPA PH 3		ON	C1	N1	1	100			11 *
CT12			OFF	A1	N1	1	100			12
CT13			OFF	B1	N1	1	100			13
CT14			OFF	C1	N1	1	100			14
CT15			OFF	A1	N1	1	100			15

Phase A" is designated as corresponding to the PT voltage C1/N1. This was done to correct an electrician's error made in labeling the wiring on the two main video store HVAC units. What had been labeled as the A-phase of two of the video store's HVAC units was connected to the C-phase of the building circuit.

Likewise, what was labeled as the C-phase of these units was connected to the A-phase of the building circuit. As long as the appropriate phases were referenced in the configuration table for the logger, the data would be monitored correctly.

The analog channels are set up next by selecting

EDIT ANALOG CHANNELS
-------------------------

The analog configuration is shown in Table A.7 for the College Station store (there were no analog channels used in the Bryan store). For logger 901/A/####/A we can see that temperature is being recorded on analog channel 10, using a scale of 1, and an offset of 0 (this is the default scaling for a 1000-Ohm, two-wire RTD connected directly to the logger). This setting automatically produces output in degrees-Fahrenheit for short lengths of wire leads.

Analog channel 11 is recording humidity using a 4-20 mA signal. In order to accomplish this we placed a Synergistics 25A118-2 resistive header module into the logger (this amounts to a 200-Ohm precision resistor placed across the A1 to GND terminals). This then allows the recorder to see 0 to 5 DC volts which are then converted to relative humidity values using a scale of 31.25, and an offset of -25.

Next, the digital channels are configured as shown in Table A.8. Digital channels are only used in the Bryan store.

EDIT DIGITAL CHANNELS
--------------------------

TABLE A.7  
Configuration Table For College Station Logger Showing Analog Channels.

```

***** Configuration for Logger: #### Parameter Set Code: A *****
----- ANALOG CHANNELS -----
Chan  Description      Search String  STA Scale  Offset  Units  T S G
-----
A 0
A 1
A 2
A 3
A 4
A 5
A 6
A 7
A 8
A 9
A10 RET AIR TEMP      ON 1 0 Deg F *
A11 RET AIR RH        ON 31.25 -25 % RH *
A12
A13
A14
A15 NOT USED!        OFF 999 -999

```

TABLE A.8  
Configuration Table For Bryan Logger Showing Digital Channels.

```

***** Configuration for Logger: #### Parameter Set Code: F *****
----- DIGITAL CHANNELS -----
Chan  Description      Search String  STA Scale  Units  TSR  AVG  RTS
-----
D 0 WHOLE BLDG PULSE  ON .288 kWh *
D 1
D 2
D 3
D 4
D 5
D 6
D 7
D 8
D 9
D10
D11
D12
D13
D14
D15

```



In the case of the Bryan store logger, whole-building electricity consumption is being recorded on digital channel 0. Units of one pulse equal to 0.288 kWh have been already assigned to the electric meter by the utility company which provided the signal.

Finally, the ordering of the configuration table is accomplished by using

```
EDIT
      TSR MEASUREMENT NUMBERS
```

The TSR configuration of the College Station logger is now complete and is shown in Table A.9 (Table A.10 for Bryan logger). This information is what is written to disk at each recording interval or Time Series Record (TSR). Table A.7 through Table A.10 are the result of printing the configuration tables to a file.

The next step is to connect PARSET to the logger using

```
CONNECT
      PHONE DIALER
      ### #####
```

PARSET will then respond with the appropriate message to tell us that the modem connection has been established at the appropriate baud rate.

Actual communications with the logger is established with the `TERMINAL` command. At this point we have various different options. If we choose

```
TERMINAL
      READ REAL TIME DATA
```

TABLE A.9  
Configuration Table for College Station Logger Showing TSR Channels.

Description -----	Variable	Meas# -----
COMPS-PHASE A	KW 0	1
COMPS-PHASE B	KW 1	2
COMPS-PHASE C	KW 2	3
PNL DPA-PHASE A	KW 3	4
PNL DPA-PHASE B	KW 4	5
PNL DPA-PHASE C	KW 5	6
PNL DPC-PHASE A	KW 6	7
PNL DPC-PHASE B	KW 7	8
PNL DPC-PHASE C	KW 8	9
PNL DPE-PHASE A	KW 9	10
PNL DPE-PHASE B	KW 10	11
PNL DPE-PHASE C	KW 11	12
VIDEO AC PHASE A	KW 12	13
VIDEO AC PHASE B	KW 13	14
VIDEO AC PHASE C	KW 14	15
RET AIR TEMP	AN 10	0
RET AIR RH	AN 11	0

TABLE A.10  
Configuration table for Bryan logger showing TSR channels.

Description -----	Variable	Meas# -----
COMPRESSORS PH 1	KW 0	1
COMPRESSORS PH 2	KW 1	2
COMPRESSORS PH 3	KW 2	3
MAIN BRANCH PH 1	KW 3	4
MAIN BRANCH PH 2	KW 4	5
MAIN BRANCH PH 3	KW 5	6
AC & LPA PH 1	KW 6	7
AC & LPA PH 2	KW 7	8
AC & LPA PH 3	KW 8	9
LPA PH 1	KW 9	10
LPA PH 2	KW 10	11
LPA PH 3	KW 11	12
	AN 0	13
	AN 1	14
WHOLE BLDG PULSE	DIG 0	19

we obtain the screen that is shown in Table A.11 or Table A.12 depending on which logger we are calling. To download and/or view TSR data we return to the TERMINAL menu. This is accomplished by pressing the ESC key. By choosing

```

TERMINAL
      READ TSR DATA
  
```

we can view and/or download Time Series Records (TSR) to the local PC for further processing. After selecting "READ TSR DATA", we see that we need to choose which TSRs to display. If we chose TSRs 284 through 309 we would have entered:

```

ENTER STARTING TSR INDEX: 284   LAST TSR INDEX IS 1152
ENTER ENDING TSR INDEX:   309   PRESENTLY WORKING ON 310
(S)CREEN OR (F)ILE OUTPUT: F
OUTPUT FILE NAME:   90193005.RAW
FILE TYPE: ASCII (R)EAL/(E)XPON, (W)K1 SPREADSHEET, (T)SR: R
HEADER TITLES? (N)ONE (A)SCII, (L)OTUS-IMPORT: N
  
```

This selects records 284 to 309 to be recorded to disk on the PC in file 90193005.RAW without headers and in floating point, ASCII format. Table A.13 is an example of what was recorded, from left to right the channels are

- Date
- TSR#
- KWH
- AMPS
- HUMIDITY
- Time
- Status
- VOLTS
- TEMP

TABLE A.11  
 Example of the TERMINAL, READ REAL TIME DATA  
 screen for College Station Store.

Logger (s)		Edit	Connect	<u>Terminal</u>		Other	Quit
Chan	AMPS	VOLTS	POWER	PF	ANALOG	COUNT	
0	456.9	116.9	41.6	0.783	-----	PC	0
1	504.3	116.9	47.6	0.845		PC	0
2	450.7	116.9	43.8	0.831		PC	0
3	397.2	116.8	45.8	0.991		PC	0
4	405.7	116.9	46.6	0.991		PC	0
5	352.8	116.7	40.5	0.986		PC	0
6	291.2	116.8	27.1	0.803		PC	0
7	275.9	115.9	25.9	0.819		PC	0
8	272.5	116.9	24.6	0.779		PC	0
9	279.0	116.0	29.8	0.908		PC	0
10	258.9	116.9	29.0	0.963	°F 70.7	PC	0
11	278.6	116.9	29.4	0.909	V 1.914	PC	0
12	26.67	115.9	2.46	0.791		PC	0
13	31.21	116.8	2.66	0.740		PC	0
14	31.83	116.9	3.08	0.831		PC	0
15	-	-	-	0.00	R 998.4	PC	0

TABLE A.12  
 Example of the TERMINAL, READ REAL TIME DATA  
 screen for Bryan Store.

Logger (s)		Edit	Connect	<u>Terminal</u>		Other	Quit
Chan	AMPS	VOLTS	POWER	PF	ANALOG	COUNT	
0	284.2	279.9	62.7	0.790	---	PC	6654
1	282.8	279.8	60.5	0.766		PC	0
2	293.0	278.4	64.7	0.794		PC	0
3	315.7	280.1	85.0	0.963		PC	0
4	296.2	279.8	80.1	0.967		PC	0
5	298.5	278.3	78.1	0.942		PC	0
6	61.3	280.0	14.1	0.823		PC	0
7	54.2	279.4	12.0	0.799		PC	0
8	59.5	278.1	12.2	0.741		PC	0
9	5.87	279.7	1.3	0.792		PC	0
10	3.89	279.5	0.45	0.422		PC	0
11	6.97	278.4	0.89	0.461		PC	0
12				0.0		PC	0
13				0.0		PC	0
14				0.0		PC	0
15	-0	-	-	0.00	R 998.4	PC	0

TABLE A.13  
90193005.RAW File Recorded for Sample Session with College Station Logger.

12/29/92	0: 0: 0	284 "V "	31.629	36.542	33.120	54.248	50.732	48.189	23.781	22.807	22.399
			16.701	18.836	19.872	0.978	1.136	1.479	66.443	49.216	
12/29/92	1: 0: 0	285 "V "	33.779	38.520	36.134	47.687	43.511	42.318	23.043	22.211	21.646
			17.973	18.459	21.222	0.710	0.833	1.090	66.330	49.266	
12/29/92	2: 0: 0	286 "V "	34.878	40.246	36.448	46.525	42.224	41.188	22.493	21.740	21.096
			19.888	19.825	23.561	0.323	0.385	0.516	66.386	48.815	
12/29/92	3: 0: 0	287 "V "	32.869	38.363	33.622	46.839	42.287	41.220	21.724	21.143	20.374
			19.370	19.433	24.408	0.304	0.369	0.498	66.162	48.865	
12/29/92	4: 0: 0	288 "V "	32.743	37.170	34.093	47.027	42.350	41.408	20.798	20.123	19.354
			20.045	18.977	22.792	0.305	0.370	0.499	66.330	48.915	
12/29/92	5: 0: 0	289 "V "	29.369	34.219	30.750	46.870	42.413	41.722	21.881	21.253	20.469
			21.253	19.589	24.644	0.306	0.364	0.485	66.218	49.166	
12/29/92	6: 0: 0	290 "V "	32.838	37.986	33.434	46.399	42.256	41.565	22.321	21.677	20.955
			21.897	20.531	25.005	0.303	0.366	0.492	66.555	49.116	
12/29/92	7: 0: 0	291 "V "	32.492	37.986	33.528	44.076	40.968	37.923	21.489	20.877	20.280
			22.870	23.263	26.622	0.304	0.370	0.506	66.836	48.815	
12/29/92	8: 0: 0	292 "V "	31.095	36.668	32.869	40.278	38.206	32.272	21.081	20.625	20.249
			27.877	26.104	26.873	0.306	0.359	0.491	66.836	48.465	
12/29/92	9: 0: 0	293 "V "	33.340	39.148	34.658	43.417	40.560	34.690	22.258	21.756	21.504
			29.369	26.904	26.841	0.311	0.394	0.544	66.499	49.066	
12/29/92	18: 0: 0	304 "V "	36.699	41.628	37.578	55.723	51.517	51.988	24.157	23.121	22.682
			23.937	26.543	24.377	1.319	1.529	1.982	67.904	49.667	
12/29/92	19: 0: 0	305 "V "	35.035	39.210	35.380	56.414	51.548	52.082	24.644	23.545	23.106
			22.179	23.372	25.052	1.306	1.512	1.954	68.185	49.316	
12/29/92	20: 0: 0	306 "V "	36.887	41.690	38.017	56.759	51.956	51.642	24.377	23.294	22.902
			20.657	22.211	24.675	1.300	1.510	1.956	67.960	49.416	
12/29/92	21: 0: 0	307 "V "	33.622	37.766	34.344	55.001	51.548	49.570	24.534	23.372	23.058
			19.809	21.991	23.671	1.305	1.504	1.958	67.623	49.366	
12/29/92	22: 0: 0	308 "V "	33.936	38.583	34.627	54.373	50.700	48.283	23.278	22.179	21.944
			19.574	20.908	21.316	1.309	1.490	1.939	67.848	49.316	
12/29/92	23: 0: 0	309 "V "	34.501	39.179	35.035	53.840	50.543	48.314	24.063	22.996	22.745
			18.365	19.699	21.646	1.297	1.495	1.952	67.679	49.116	

## A.4 PROCESSING THE COLLEGE STATION AND BRYAN DATA

This section provides the reader with instructions on what was done with the data once they were collected from the loggers. Examples will focus on the data stream for the College Station Store. Instructions and sample code are provided for developing summary inspection plots and 3-D plots using a combination of public-domain data processing tool kits and inexpensive, commercially-available plotting software.

### A.4.1 Processing/Plotting Synergistics Data

**Process Overview.** This section describes a collection of routines that were used to process and plot data collected from data loggers. These routines have been used in the case-study on a weekly basis to create a set of *inspection plots* which were used as the primary data quality-control measure.

Controller batch files are used to call the routines in sequence; once a production mode is established for creating the plots for a particular building, only a few keystrokes are required to actually create the graphic report. The routines used to process the data include:

- 1) Automated quality-control checks of all data channels against static lower and upper bounds.
- 2) Insertion of missing records with bad data markers (-99).
- 3) Creation of summary inspection plots for each data stream of interest.

The processing stream makes these assumptions:

- 1) Data are being collected on an hourly basis.
- 2) Each data file to be processed contains *exactly one week* worth of hourly records.
- 3) Each site (data logger) has an associated three-digit code. The example used herein is site 901 - the College Station grocery store.
- 4) The raw data recorded from the Synergistics logger have been stored into a file (90193005.RAW) using real numbers without headers from the Synergistics software.

- 5) The file name used to record the raw data follows the strict format of XXXYYDDD.RAW where XXX is the three-digit site code, YY is the year, and DDD is the number of the day during which the data were collected (which is the day *after* the last day in the data file). Collectively, YYDDD is known as the *Julian date*. As an example, the raw data file included on the distribution diskette is 90193005.RAW (TABLE A.14). This is data for site 901. Because it was collected on 93005 (the 005th day of 1993 or January 5, 1993), this file contains data for the period beginning 92364 (Dec. 29, 1992 at midnight) and ending 93004 (Jan. 4, 1993 at 11:00 p.m.).
- 6) To print summary plots, a weekly weather file containing hourly data for the region is present (00193005.WEA). The weather data were taken from the weather station at Zachry Engineering Center, on the campus of Texas A&M University, located approximately two miles from either the College Station or Bryan grocery store.
- 7) The commercially-available graphing program GRAPHER (Golden 1990) is used to create the plots.
- 8) The public domain programs ARCHIVE and COLS (Feuermann and Kempton 1987), and GAWK(FSF 1989) are used for quality-control and data manipulation.
- 9) The subdirectory \TEMP has been created prior to running the routines. This directory is used to store all work files during the processing of the data and graphs.

The following sections discuss the methodology of these routines as well as possible modifications for plotting other metered data.

TABLE A.14

Example Synergistics Raw Data Format 90193005.RAW.

12/29/92	0: 0: 0	284 "V "	31.629	36.542	33.120	54.248	50.732	48.189	23.781	22.807	22.399
			16.701	18.836	19.872	0.978	1.136	1.479	66.443	49.216	
12/29/92	1: 0: 0	285 "V "	33.779	38.520	36.134	47.687	43.511	42.318	23.043	22.211	21.646
			17.973	18.459	21.222	0.710	0.833	1.090	66.330	49.266	
12/29/92	2: 0: 0	286 "V "	34.878	40.246	36.448	46.525	42.224	41.188	22.493	21.740	21.096
			19.888	19.825	23.561	0.323	0.385	0.516	66.386	48.815	
12/29/92	3: 0: 0	287 "V "	32.869	38.363	33.622	46.839	42.287	41.220	21.724	21.143	20.374
			19.370	19.433	24.408	0.304	0.369	0.498	66.162	48.865	
12/29/92	4: 0: 0	288 "V "	32.743	37.170	34.093	47.027	42.350	41.408	20.798	20.123	19.354
			20.045	18.977	22.792	0.305	0.370	0.499	66.330	48.915	
12/29/92	5: 0: 0	289 "V "	29.369	34.219	30.750	46.870	42.413	41.722	21.881	21.253	20.469
			21.253	19.589	24.644	0.306	0.364	0.485	66.218	49.166	
12/29/92	6: 0: 0	290 "V "	32.838	37.986	33.434	46.399	42.256	41.565	22.321	21.677	20.955
			21.897	20.531	25.005	0.303	0.366	0.492	66.555	49.116	
12/29/92	7: 0: 0	291 "V "	32.492	37.986	33.528	44.076	40.968	37.923	21.489	20.877	20.280
			22.870	23.263	26.622	0.304	0.370	0.506	66.836	48.815	
12/29/92	8: 0: 0	292 "V "	31.095	36.668	32.869	40.278	38.206	32.272	21.081	20.625	20.249
			27.877	26.104	26.873	0.306	0.359	0.491	66.836	48.465	
12/29/92	9: 0: 0	293 "V "	33.340	39.148	34.658	43.417	40.560	34.690	22.258	21.756	21.504
			29.369	26.904	26.841	0.311	0.394	0.544	66.499	49.066	
12/29/92	18: 0: 0	304 "V "	36.699	41.628	37.578	55.723	51.517	51.988	24.157	23.121	22.682
			23.937	26.543	24.377	1.319	1.529	1.982	67.904	49.667	
12/29/92	19: 0: 0	305 "V "	35.035	39.210	35.380	56.414	51.548	52.082	24.644	23.545	23.106
			22.179	23.372	25.052	1.306	1.512	1.954	68.185	49.316	
12/29/92	20: 0: 0	306 "V "	36.887	41.690	38.017	56.759	51.956	51.642	24.377	23.294	22.902
			20.657	22.211	24.675	1.300	1.510	1.956	67.960	49.416	
12/29/92	21: 0: 0	307 "V "	33.622	37.766	34.344	55.001	51.548	49.570	24.534	23.372	23.058
			19.809	21.991	23.671	1.305	1.504	1.958	67.623	49.366	
12/29/92	22: 0: 0	308 "V "	33.936	38.583	34.627	54.373	50.700	48.283	23.278	22.179	21.944
			19.574	20.908	21.316	1.309	1.490	1.939	67.848	49.316	
12/29/92	23: 0: 0	309 "V "	34.501	39.179	35.035	53.840	50.543	48.314	24.063	22.996	22.745
			18.365	19.699	21.646	1.297	1.495	1.952	67.679	49.116	



### Preparing Data from Time Series Channels from Raw Synergistics

**Data with R2A.BAT.** Given this set of filters and programs, a rudimentary quality-control range check can be performed and a full set of time series plots can be created with a simple command line operation. To perform the quality-control and produce plots, type:

```
C:\TEMP> R2A.BAT 901 93005 90001 <enter>
```

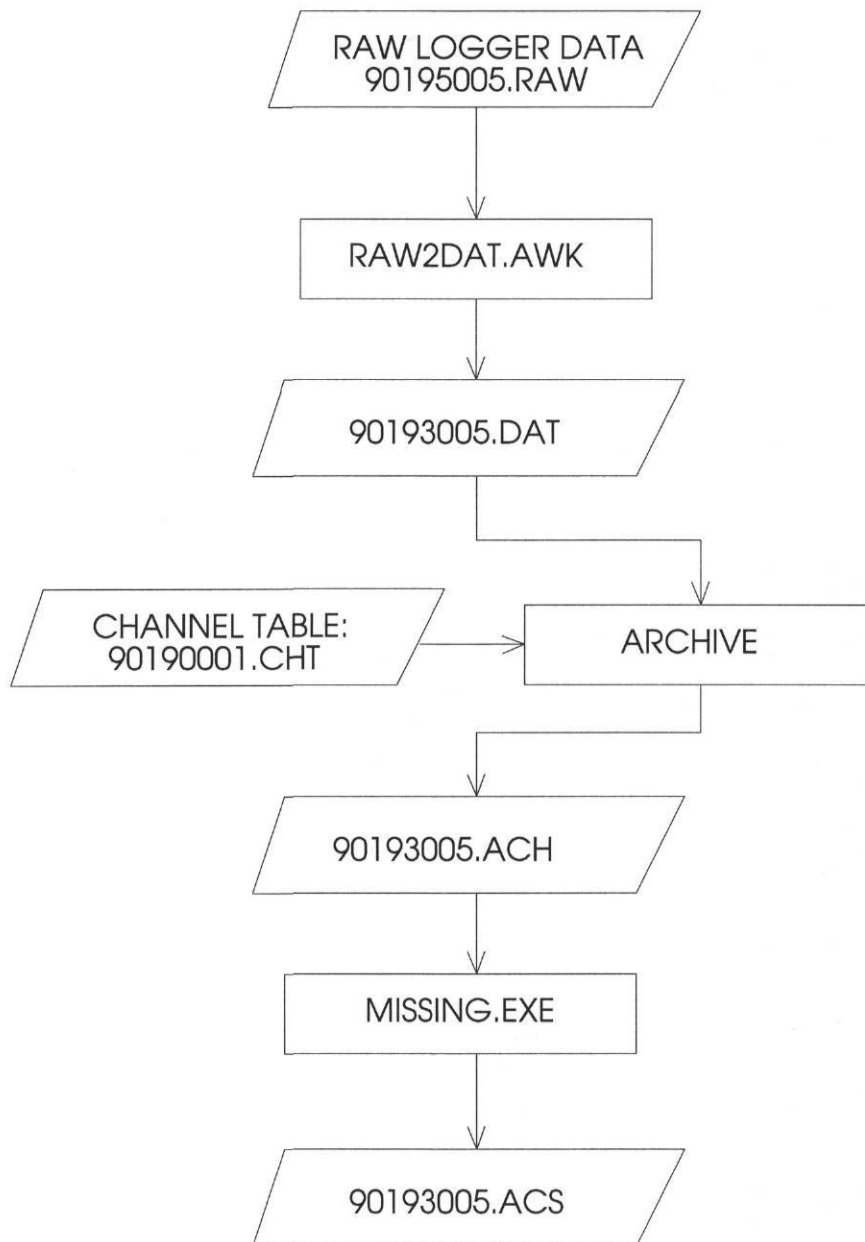
This command calls the controlling batch file R2A.BAT to begin the process as shown in Figure A.13. The parameters passed to R2A.BAT include the three-digit logger code (901), a Julian polling date (93005), and a channel table descriptor (90001). R2A.BAT uses the logger code and Julian date to understand which file to process.

R2A utilizes an ARCHIVE channel table which is a data dictionary that attaches static high/low bounds, English language descriptions, and scaling factors to each data column. The channel table descriptor tells R2A.BAT which channel table is to be used for the data being processed.

The output of this scheme includes the "flat" file, 90193005.ACH, which is incorporated into a database. A flowchart for R2A.BAT is given as Figure A.19.

Briefly, these steps are performed by R2A.BAT:

Step 1) The GAWK script RAW2DAT.AWK is called to preprocess the raw data 90193005.RAW for quality-control checks. Quality-control is performed by the



**FIGURE A.13** *Flow chart for R2A.BAT data processing procedure.*

public domain program ARCHIVE (Feuerman and Kempton, 1989) which is unable to understand some of the characters that the Synergistics software leaves in the 90193005.RAW file. An example of Synergistics data are given as Table A.14. The output of RAW2DAT.AWK is given as Table A.15. Notice date/time columns have been adjusted, and that certain characters have been stripped-out of the file (e.g., "/", ":", etc.).

Step 2) The output of RAW2DAT and the site's ARCHIVE channel table are fed into ARCHIVE for static high/low range checking. The ARCHIVE channel table 90190001.CHT for the College Station store, site 901, is given as Table A.16 (and for the Bryan store, site 913, as Table A.17). Example output from ARCHIVE is given as Table A.18. ARCHIVE will report any offending data readings in a log file and will replace such readings in the data with a "bad data" marker (Table A.19). Currently, this marker is the value, -99. ARCHIVE automatically appends the DOS file extension ".ACH" to the filename. For the example data set provided, this step will have created the file 90193005.ACH.

An ARCHIVE channel table must be created manually for each site and contains the instructions that ARCHIVE uses to process the data from each site. In Table A.16, the ARCHIVE channel table 90190001.CHT is shown which processes the data from site 901. The first four lines of the channel table are labels for the columns below. The line beginning with "#" contains special characters that tell ARCHIVE what kind of data it is processing, and what to use as a missing variable (the default is -99).

The first eight characters are the date that the parameters are to be applied. Excluding the last line, this is "07/03/90" for site 901 which is the most recent date for this parameter set. It does not need to coincide with the first date in the data to be processed, but must be prior to it.

The next variable is the time, in this case "00:00". This is instructing ARCHIVE to begin processing on July 3, 1990 at midnight.

TABLE A.15  
 Example output 90193005.DAT from RAW2DAT program.

12 29 92	0 0	31.629	36.542	33.120	54.248	50.732	48.189	23.781	22.807	22.399	16.701
		18.836	19.872	0.978	1.136	1.479	66.443	49.216			
12 29 92	1 0	33.779	38.520	36.134	47.687	43.511	42.318	23.043	22.211	21.646	17.973
		18.459	21.222	0.710	0.833	1.090	66.330	49.266			
12 29 92	2 0	34.878	40.246	36.448	46.525	42.224	41.188	22.493	21.740	21.096	19.888
		19.825	23.561	0.323	0.385	0.516	66.386	48.815			
12 29 92	3 0	32.869	38.363	33.622	46.839	42.287	41.220	21.724	21.143	20.374	19.370
		19.433	24.408	0.304	0.369	0.498	66.162	48.865			
12 29 92	4 0	32.743	37.170	34.093	47.027	42.350	41.408	20.798	20.123	19.354	20.045
		18.977	22.792	0.305	0.370	0.499	66.330	48.915			
12 29 92	5 0	29.369	34.219	30.750	46.870	42.413	41.722	21.881	21.253	20.469	21.253
		19.589	24.644	0.306	0.364	0.485	66.218	49.166			
12 29 92	6 0	32.838	37.986	33.434	46.399	42.256	41.565	22.321	21.677	20.955	21.897
		20.531	25.005	0.303	0.366	0.492	66.555	49.116			
12 29 92	7 0	32.492	37.986	33.528	44.076	40.968	37.923	21.489	20.877	20.280	22.870
		23.263	26.622	0.304	0.370	0.506	66.836	48.815			
12 29 92	8 0	31.095	36.668	32.869	40.278	38.206	32.272	21.081	20.625	20.249	27.877
		26.104	26.873	0.306	0.359	0.491	66.836	48.465			
12 29 92	9 0	33.340	39.148	34.658	43.417	40.560	34.690	22.258	21.756	21.504	29.369
		26.904	26.841	0.311	0.394	0.544	66.499	49.066			
12 29 92	18 0	36.699	41.628	37.578	55.723	51.517	51.988	24.157	23.121	22.682	23.937
		26.543	24.377	1.319	1.529	1.982	67.904	49.667			
12 29 92	19 0	35.035	39.210	35.380	56.414	51.548	52.082	24.644	23.545	23.106	22.179
		23.372	25.052	1.306	1.512	1.954	68.185	49.316			
12 29 92	20 0	36.887	41.690	38.017	56.759	51.956	51.642	24.377	23.294	22.902	20.657
		22.211	24.675	1.300	1.510	1.956	67.960	49.416			
12 29 92	21 0	33.622	37.766	34.344	55.001	51.548	49.570	24.534	23.372	23.058	19.809
		21.991	23.671	1.305	1.504	1.958	67.623	49.366			
12 29 92	22 0	33.936	38.583	34.627	54.373	50.700	48.283	23.278	22.179	21.944	19.574
		20.908	21.316	1.309	1.490	1.939	67.848	49.316			
12 29 92	23 0	34.501	39.179	35.035	53.840	50.543	48.314	24.063	22.996	22.745	18.365
		19.699	21.646	1.297	1.495	1.952	67.679	49.116			

TABLE A.16

Example Channel Table for the 90190001.CHT Archive Program.

Date MM/DD/YY (YY DDD)	Time HH:mm	Raw-Data lin pos	Arch coln pos	Name of Arch Channel	Archive Units	Arch Format	Conv'n Code	Conv'n Consts	Error Code	Error Constants	Channel Description
#											
07/03/90	00:00	1	0	0	Begin	Store-S					Beginning date
07/03/90	00:00	1	1	1	Bldg. #	xx	I3	2	0 901	0	Building Number
07/03/90	00:00	1	1	2	Mon-Raw	MM	I3	1		0	Month
07/03/90	00:00	1	2	3	Mon-Raw	DD	I3	1		0	Day
07/03/90	00:00	1	3	4	Mon-Raw	YY	I3	1		0	Year
07/03/90	00:00	1	3	5	Greg-Jul	MMDDYY	I5	24	1 2	0	Gregorian Date to Julian
07/03/90	00:00	1	4	7	Time	HH mm	I5	16	5	0	Time
07/03/90	00:00	1	3	6	Greg-Dec	DDD.frac	F10.4	28		0	Gregorian Date to
Jul.Dec											
07/03/90	00:00	1	6	8	Comps A	F9.3	F9.3	1		1 -5 99999	Cmprssrs Ph A (kWh/h)
07/03/90	00:00	1	7	9	Comps B	F9.3	F9.3	1		1 -5 99999	Cmprssrs Ph B (kWh/h)
07/03/90	00:00	1	8	10	Comps C	F9.3	F9.3	1		1 -5 99999	Cmprssrs Ph C (kWh/h)
07/03/90	00:00	1	9	11	PnlDPA A	F9.3	F9.3	1		1 -5 99999	Panel DPA Ph A (kWh/h)
07/03/90	00:00	1	10	12	PnlDPA B	F9.3	F9.3	1		1 -5 99999	Panel DPA Ph B (kWh/h)
07/03/90	00:00	1	11	13	PnlDPA C	F9.3	F9.3	1		1 -5 99999	Panel DPA Ph C (kWh/h)
07/03/90	00:00	1	12	14	PnlDPC A	F9.3	F9.3	1		1 -5 99999	Panel DPC Ph A (kWh/h)
07/03/90	00:00	1	13	15	PnlDPC B	F9.3	F9.3	1		1 -5 99999	Panel DPC Ph B (kWh/h)
07/03/90	00:00	1	14	16	PnlDPC C	F9.3	F9.3	1		1 -5 99999	Panel DPC Ph C (kWh/h)
07/03/90	00:00	1	15	17	PnlDPE A	F9.3	F9.3	1		1 -5 99999	Panel DPE Ph A (kWh/h)
07/03/90	00:00	1	16	18	PnlDPE B	F9.3	F9.3	1		1 -5 99999	Panel DPE Ph B (kWh/h)
07/03/90	00:00	1	17	19	PnlDPE C	F9.3	F9.3	1		1 -5 99999	Panel DPE Ph C (kWh/h)
07/03/90	00:00	1	18	20	VideoS A	F9.3	F9.3	1		1 -5 99999	Video Store Ph A (kWh/h)
07/03/90	00:00	1	19	21	VideoS B	F9.3	F9.3	1		1 -5 99999	Video Store Ph B (kWh/h)
07/03/90	00:00	1	20	22	VideoS C	F9.3	F9.3	1		1 -5 99999	Video Store Ph C (kWh/h)
11/20/92	00:00	1	21	23	RetAir T	F9.3	F9.3	1		1 -5 150	AHU Return Air Temp (F)
11/20/92	00:00	1	22	24	RetAirRH	F9.3	F9.3	1		1 0 105	AHU Return Air RH
03/11/99	23:00	1	0	0	End	Store-S					

TABLE A.17

Example channel table for the 91390001.CHT ARCHIVE program.

Date MM/DD/YY (YY DDD)	Time HH:mm	Raw-Data lin pos	Arch coln pos	Name of Arch Channel	Archive Units	Arch Format	Conv'n Code	Conv'n Consts	Error Code	Error Constants	Channel Description
#											
10/06/92	00:00	1	0	0	Begin	Store-Bry					Beginning date
10/06/92	00:00	1	1	1	Bldg. #	xx	I3	2	0 913	0	Building Number
10/06/92	00:00	1	1	2	Mon-Raw	MM	I3	1		0	Month
10/06/92	00:00	1	2	3	Mon-Raw	DD	I3	1		0	Day
10/06/92	00:00	1	3	4	Mon-Raw	YY	I3	1		0	Year
10/06/92	00:00	1	3	5	Greg-Jul	MMDDYY	I5	24	1 2	0	Gregorian Date to
Julian											
10/06/92	00:00	1	4	7	Time	HH mm	I5	16	5	0	Time
10/06/92	00:00	1	3	6	Greg-Dec	DDD.frac	F10.4	28		0	Gregorian Date to
Jul.Dec											
10/06/92	00:00	1	6	8	Comps A	F9.3	F9.3	1		1 -5 1000	Cmprssrs Ph A (kWh/h)
10/06/92	00:00	1	7	9	Comps B	F9.3	F9.3	1		1 -5 1000	Cmprssrs Ph B (kWh/h)
10/06/92	00:00	1	8	10	Comps C	F9.3	F9.3	1		1 -5 1000	Cmprssrs Ph C (kWh/h)
10/06/92	00:00	1	9	11	MainBr A	F9.3	F9.3	1		1 -5 1000	Main Branch Ph A
(kWh/h)											
10/06/92	00:00	1	10	12	MainBr B	F9.3	F9.3	1		1 -5 1000	Main Branch Ph B
(kWh/h)											
10/06/92	00:00	1	11	13	MainBr C	F9.3	F9.3	1		1 -5 1000	Main Branch Ph C
(kWh/h)											
10/06/92	00:00	1	12	14	AC LPA A	F9.3	F9.3	1		1 -5 1000	AC LPA Ph A (kWh/h)
10/06/92	00:00	1	13	15	AC LPA B	F9.3	F9.3	1		1 -5 1000	AC LPA Ph B (kWh/h)
10/06/92	00:00	1	14	16	AC LPA C	F9.3	F9.3	1		1 -5 1000	AC LPA Ph C (kWh/h)
10/06/92	00:00	1	15	17	LPA A	F9.3	F9.3	1		1 -5 1000	LPA Ph A (kWh/h)
10/06/92	00:00	1	16	18	LPA B	F9.3	F9.3	1		1 -5 1000	LPA Ph B (kWh/h)
10/06/92	00:00	1	17	19	LPA C	F9.3	F9.3	1		1 -5 1000	LPA Ph C (kWh/h)
10/06/92	00:00	1	18	20	FutureAn	F9.3	F9.3	1		1 -5 99999	Future Analog
10/06/92	00:00	1	19	21	FutureAn	F9.3	F9.3	1		1 -5 99999	Future Analog
10/06/92	00:00	1	20	22	WBE	F9.3	F9.3	1		1 0 999999	Whole Building (kWh/h)
03/11/99	23:00	1	0	0	End	Store-Bry					

TABLE A.18  
Output From The Archive Program, File 90193005.ACH.

901	12	29	92	92364	4746.0000	0	31.629	36.542	33.120	54.248	50.732	48.189	23.781
22.807													
22.399 16.701 18.836 19.872 0.978 1.136 1.479 66.443 49.216													
901	12	29	92	92364	4746.0417	100	33.779	38.520	36.134	47.687	43.511	42.318	23.043
22.211													
21.646 17.973 18.459 21.222 0.710 0.833 1.090 66.330 49.266													
901	12	29	92	92364	4746.0833	200	34.878	40.246	36.448	46.525	42.224	41.188	22.493
21.740													
21.096 19.888 19.825 23.561 0.323 0.385 0.516 66.386 48.815													
901	12	29	92	92364	4746.1250	300	32.869	38.363	33.622	46.839	42.287	41.220	21.724
21.143													
20.374 19.370 19.433 24.408 0.304 0.369 0.498 66.162 48.865													
901	12	29	92	92364	4746.1667	400	32.743	37.170	34.093	47.027	42.350	41.408	20.798
20.123													
19.354 20.045 18.977 22.792 0.305 0.370 0.499 66.330 48.915													
901	12	29	92	92364	4746.2083	500	29.369	34.219	30.750	46.870	42.413	41.722	21.881
21.253													
20.469 21.253 19.589 24.644 0.306 0.364 0.485 66.218 49.166													
901	12	29	92	92364	4746.2500	600	32.838	37.986	33.434	46.399	42.256	41.565	22.321
21.677													
20.955 21.897 20.531 25.005 0.303 0.366 0.492 66.555 49.116													
901	12	29	92	92364	4746.2917	700	32.492	37.986	33.528	44.076	40.968	37.923	21.489
20.877													
20.280 22.870 23.263 26.622 0.304 0.370 0.506 66.836 48.815													
901	12	29	92	92364	4746.3333	800	31.095	36.668	32.869	40.278	38.206	32.272	21.081
20.625													
20.249 27.877 26.104 26.873 0.306 0.359 0.491 66.836 48.465													
901	12	29	92	92364	4746.3750	900	33.340	39.148	34.658	43.417	40.560	34.690	22.258
21.756													
21.504 29.369 26.904 26.841 0.311 0.394 0.544 66.499 49.066													
:													
:													
:													
901	12	29	92	92364	4746.7500	1800	36.699	41.628	37.578	55.723	51.517	51.988	24.157
23.121													
22.682 23.937 26.543 24.377 1.319 1.529 1.982 67.904 49.667													
901	12	29	92	92364	4746.7917	1900	35.035	39.210	35.380	56.414	51.548	52.082	24.644
23.545													
23.106 22.179 23.372 25.052 1.306 1.512 1.954 68.185 49.316													
901	12	29	92	92364	4746.8333	2000	36.887	41.690	38.017	56.759	51.956	51.642	24.377
23.294													
22.902 20.657 22.211 24.675 1.300 1.510 1.956 67.960 49.416													
901	12	29	92	92364	4746.8750	2100	33.622	37.766	34.344	55.001	51.548	49.570	24.534
23.372													
23.058 19.809 21.991 23.671 1.305 1.504 1.958 67.623 49.366													
901	12	29	92	92364	4746.9167	2200	33.936	38.583	34.627	54.373	50.700	48.283	23.278
22.179													
21.944 19.574 20.908 21.316 1.309 1.490 1.939 67.848 49.316													
901	12	29	92	92364	4746.9583	2300	34.501	39.179	35.035	53.840	50.543	48.314	24.063
22.996													
22.745 18.365 19.699 21.646 1.297 1.495 1.952 67.679 49.116													

TABLE A.19  
Example .LOG file from the ARCHIVE program.

```

Log of Archive, version: 1.41 of 15 June 1987,      processed on 5 Jan 1993

Files:

      RAW DATA 90193500.dat
CHANNEL TABLE 90190001.cht
      ARCHIVE 90193005.ACS
      LOG 90193005.log

Archive delimiter is " ".
Missing or bad data values are replaced by the value -99.000 .

Line errors: are identified by their line number in the raw data file.
Data errors: are identified by the channels name, line and position
              within the case: "name "(line in case/position in line).
Line numbers in raw data file are shown as |number| or as *number*
              |numbers| indicates a line of data, *numbers* is a comment line.

First case on raw data: 92 364 00:00

-----
BeginDate: 92 114 00:00                      First output case: 92 364 00:00
-----

-----
EndDate:   99 901 23:00                      Last output case: 93 004 23:00
-----

STATISTICS:

168 lines read from beginning of raw data file.
168 lines processed between Begin and End dates.
  (including 0 comments and 0 all-blank lines)
  0 line errors detected.

0 data errors, and 0 missing data detected

```

Next are the line number and column number of the input channel. These are followed by the ARCHIVE output column number. A "0" value is essentially a comment line and does not appear in the .ACH file.

Following the ARCHIVE column position indicator is an eight character descriptor of the channel. This is followed by another twelve character descriptor of the ARCHIVE units and a six character code word for the ARCHIVE output format.

The next two variables contain the conversion code word and conversion constants. The conversion code word is an integer from 1 to 31 and instructs ARCHIVE whether or not to perform conversions on the incoming data. Conversion code "0" will place a missing variable into this column, code "1" is an identity code that allows the value to pass through ARCHIVE untouched, code "2" is a linear transformation that requires two constants (i.e., slope and intercept), and so forth.

The last three columns contain the error code, error constants, and channel description. The error checking code is an 1=on, 0=off code that initiates the high/low limit checking which makes use of the high/low limit values that immediately follow.

In the 90190001.CHT channel table in Table A.16, there are 24 lines of input. The first line,

07/03/90 00:00 1 0 0 Begin Store-S Beginning Date
---

is basically a comment line that does not appear in the output. The next line

07/03/90 00:00 1 1 1 Bldg.# XX I3 2 0 901 0 Building Number
---

places the site number "901" in the first column of the ARCHIVE output. This is done by using a linear transformation of slope = 0 and intercept = 901.



The next six lines,

07/03/90	2
↓	↓
07/03/90	7

create the second through seventh columns in the output file, 90193005.ACH. The second, third, and fourth columns in 90193005.ACH are the month, day and year that are simply passed through ARCHIVE without change. The fifth output column is the Julian date (92364), that is calculated by ARCHIVE using the first, second, and third input columns. The sixth column is the decimal date (4746.000) that is calculated by ARCHIVE. The decimal date is a combined date and time stamp that is an offset number of days and hours from January 1, 1980. It is similar to the @DATE(YR,MO,DAY) function that is used in many spreadsheets. The seventh column is the hour of the day using military notation (i.e., 0 to 23 hours). Columns eight through twenty-four in 90193005.ACH all contain monitored data, in this case from the College Station grocery store building.

Step 3) For the processing of the grocery store data, the final step of R2A is to feed the .ACH file to the program MISSING. This program scans the time stamps and inserts records and appropriate bad data markers in place of any missing records. When a logger loses power in the field, it stops recording TSRs, and begins recording TSRs when the power is restored. However, a hole will exist in the data for those periods when the power was off. This hole is filled with -99 values to aid in file merging and in graph readability. The output of MISSING uses the file extension ".ACS". This is the ASCII flat file from which all subsequent plots are made. When there are no missing data there is no difference between an .ACH and .ACS file except the filename extension.

**Using GRAPHER to Create an Individual Graph.** GRAPHER is one of many commercially available general purpose graphics software packages. GRAPHER is very useful for rapidly plotting data because of its flexibility, overlay, and programmable batch mode operation. GRAPHER is actually

composed of several sub-programs as shown in Figure A.14. The most important of these (once configured) are the VIEW and PLOT programs. VIEW allows one to quickly preview a graph that has been created. PLOT translates GRAPHER's .PLT file into device-specific plot instructions for printer output.

In general, to produce a plot with GRAPHER, one needs data files (.DAT) and plotting instruction files (.GRF). GRAPHER also allows for additional customization with axis (.AXS), grid (.GRD), dividing line (.DIV) and text (.TXT) files, although custom information can be stored in the general .GRF files.

Figure A.15 shows the result of processing the "T901\_03.GRF" GRAPHER instruction file. Table A.30 contains a summary of the graphic instructions contained in the T901\_03.GRF file. Table A.31 is the T901\_03.GRF file that GRAPHER produces. From Table A.30, one can see that input file, 901week.DAT, is being used and that a linear X-Y plot is being produced using the sixth column (F) for X and the eleventh column (J) for the Y variable. GRAPHER produces a time series graph since the X variable is actually the decimal date and a solid line without symbols is being used to plot the data. Each graph that is to be plotted requires a .GRF file. The use of GRAPHER to produce weekly inspection plots is reasonably efficient because the same .GRF file (modified slightly) can be used with each week's data.

#### **A.4.2 Description of the Summary Inspection Plots from Raw Synergistics Data and Area Weather Data**

**The Need for Summary Plots.** Because each building usually has a unique parameter set, summary inspection plot pages have been created to produce a generalized scheme for quickly inspecting data collected from multiple buildings. A summary plot page contains whole-building and sub-metered information presented in a standard orientation.

The motivation for creating such a page is two-fold. First, in both grocery stores, electricity load readings are recorded on multiple channels (e.g. A, B, and C phases). It is the sum of these phases that is of interest. Second, summary plot pages decrease the time required during plot inspection because they present combined-phase data. It was found early on in the study that pages such as these are tremendously helpful for visual quality-control.

TABLE A.30  
Summary of GRAPHER instructions for graph T901\_03.GRF.

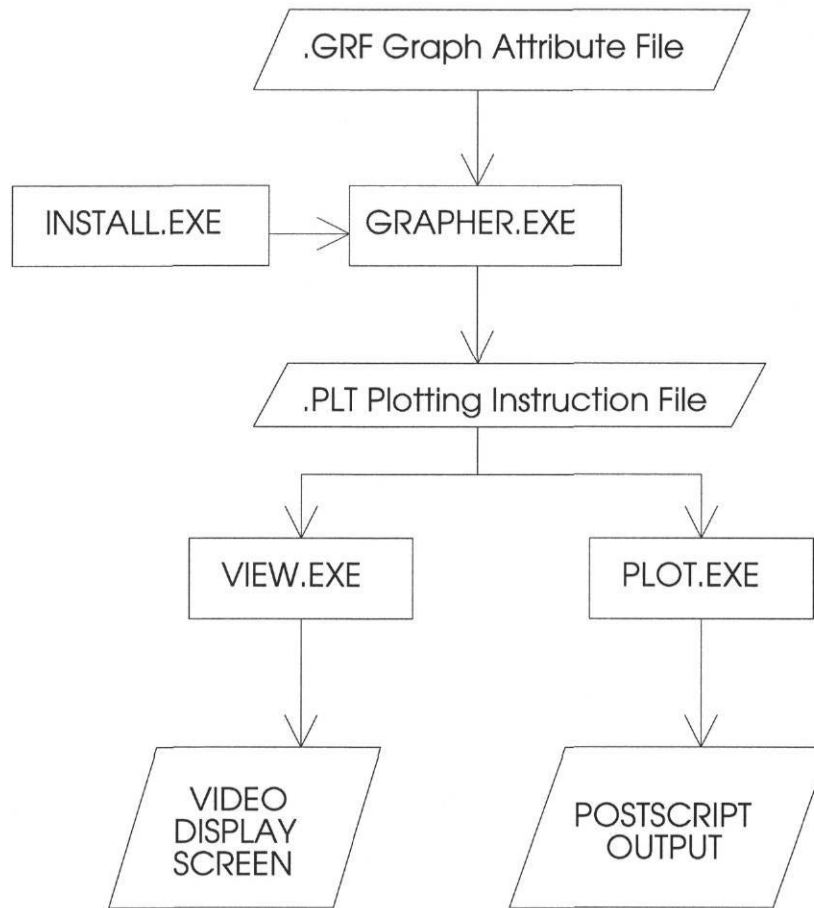
	AXIS		DATA	COLUMNS		CENTERED BEST		
	X	Y	FILENMS	X	Y	LINE	SYM.	FIT
TYPE:	LINEAR	LINEAR	901week	F	J	SOLID	NO	NO
TITLE:	Site 901 Building Meter							
START:	1.5,1.0	1.5,1.0						
LENGTH:	6.0	6.0						
START:	4543.0	0.0						
END:	4550.0	AUTOMATIC						
TICS:	YES	YES						
TIC LABEL:	YES	YES						
AXIS FILE:	X-AXIS	Y-AXIS						
GRID FILE:	none	none						
TEXT FILE:	none	none						
DIV.FILE:	none	none						

TABLE A.31  
T901\_03.GRF GRAPHER file.

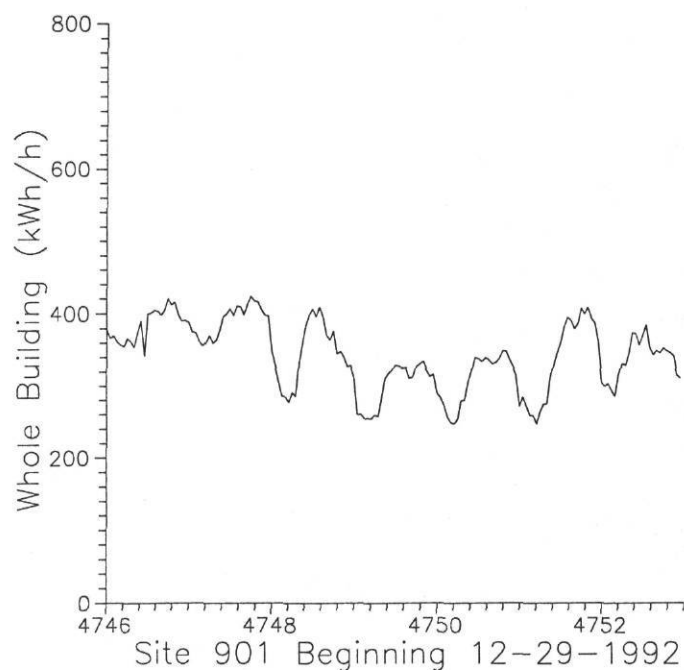
```

1243
1 2 0 0 0
901week
78 75 48 14"NO " 48
"NO" "SOLID" 1.500e-001 1
"YES" 41 1.000e-001 1 1
48 9.900e+028 9.900e+028 0.000e+000 "DEFAULT" 1.000e-001 1
"SOLID" 0 1.500e-001 9.9000000e+029 9.9000000e+029 200 2.000e+000
1
0.0000000e+000 9.9000000e+029 0.0000000e+000 9.9000000e+029
1.500e-001
X-AXIS
1.5000000e+000 1.0000000e+000 6.0000000e+000 88
0.0000000e+000 1.2000000e+002 9.9000000e+028 1 1
0.0000000e+000 9.9000000e+028 1.5000000e-001 1 1
10 0 1
1 9.9000000e+028 0.0000000e+000 9.9000000e+028 1.8000000e-001
"DEFAULT" "DEFAULT" "Dry Bulb Temperature"
4.0000000e-002
Y-AXIS
1.5000000e+000 1.0000000e+000 6.0000000e+000 89
0.0000000e+000 2.0000000e+002 9.9000000e+028 1 1
2.7000000e+002 9.9000000e+028 1.5000000e-001 1 1
10 0 1
1 9.9000000e+028 0.0000000e+000 9.9000000e+028 1.8000000e-001
"DEFAULT" "DEFAULT" "Utility (kwh/h)"
4.0000000e-002

```

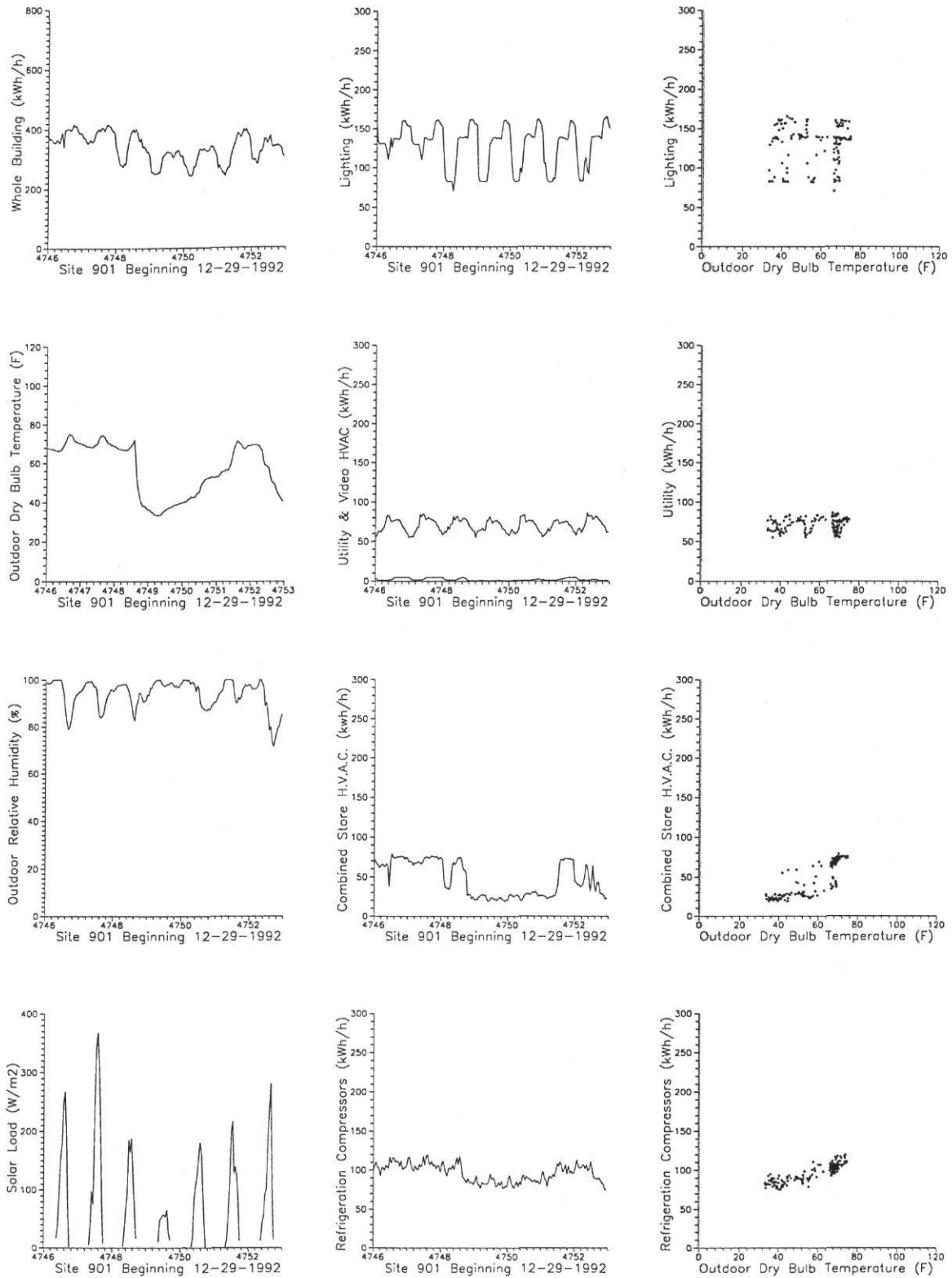


**Figure A.14** Flow chart for the GRAPHER program.



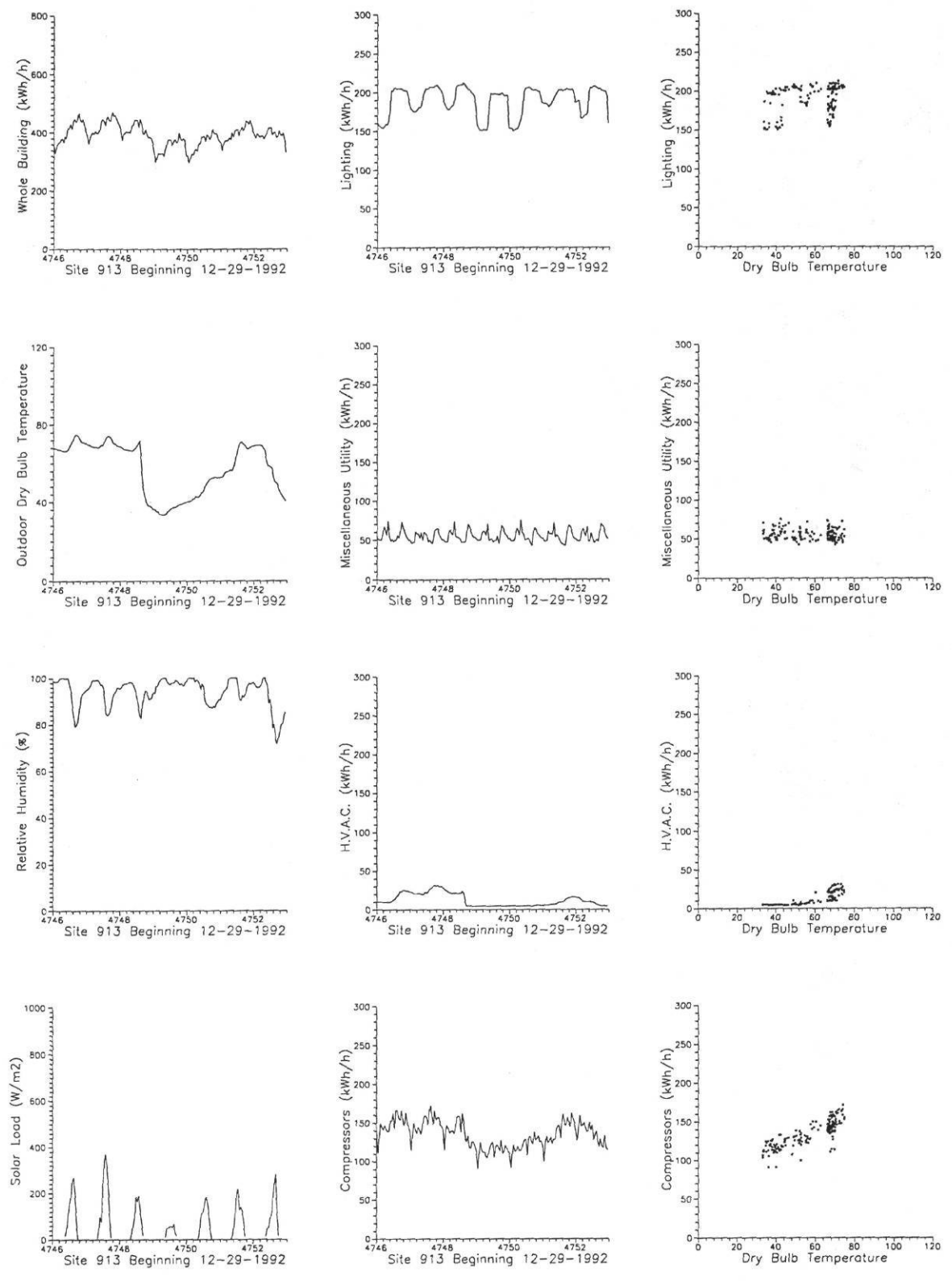
**Figure A.15** *Graph created with T901\_03.GRF and 901week.DAT data file.*

Examples summary pages are shown in Figure A.16 and Figure A.17 for the College Station and Bryan stores, respectively. The first column of the summary pages contains a time series plot of whole building electric for the site, as well as weather time series data (outdoor dry-bulb temperature, relative humidity, and solar radiation) for the region. In this case, the loggers used in the College Station and Bryan stores do not have their own weather stations. Therefore weather data from a nearby site at Texas A&M University must be merged in from an outside file, 001\*.WEA. The second column contains time series graphs of building sub-metered electricity loads. The third and final column contains scatter plots of the same data points in the second column plotted against outdoor dry-bulb temperature for the region.



**FIGURE A.16**

*Example of the first 12 summary page plots from the College Station store.*



**FIGURE A.17** Example of the summary plots from the Bryan store.

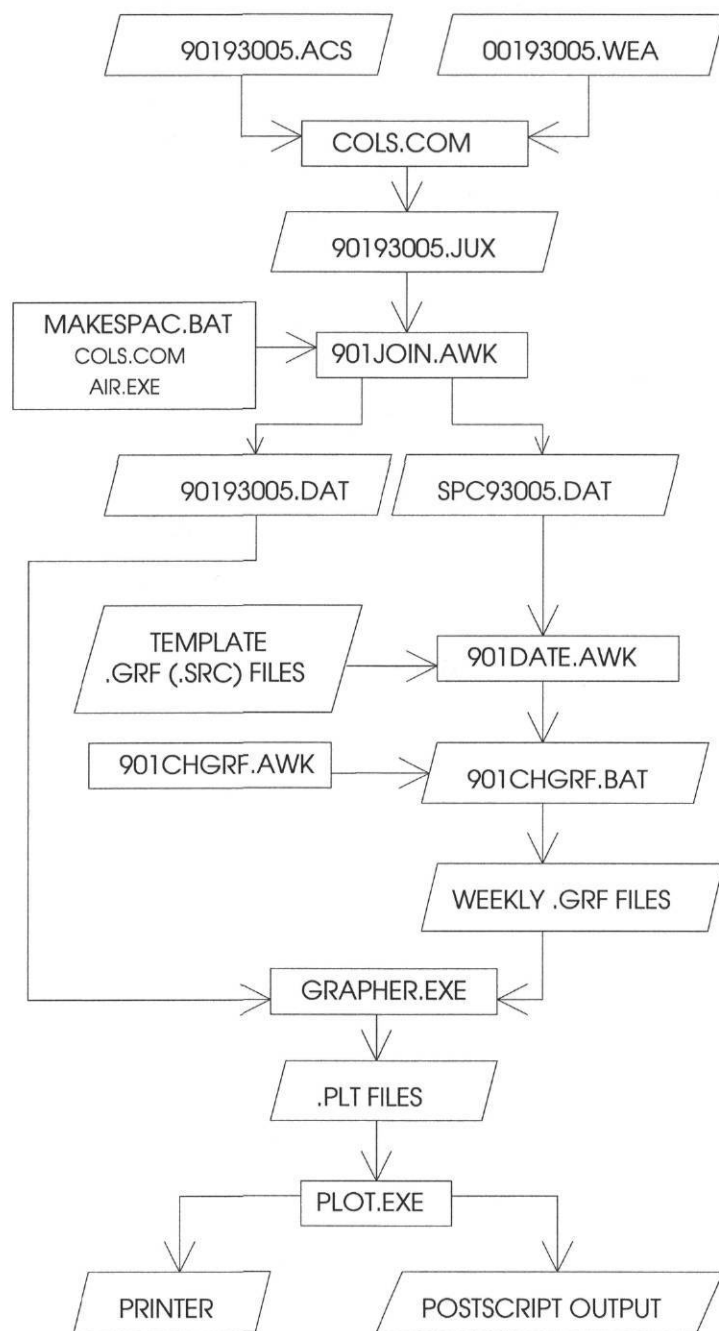
**Creating Graphs Using 901SUM.BAT.** 901SUM.BAT is another controlling batch file. Its function is to automatically produce a set of time series plots (Figure A.16) -- one per sub-metered load (refrigeration compressors, lighting, HVAC, and miscellaneous utility). A flowchart for 901SUM.BAT is given as Figure A.18. Briefly, these steps are performed by 901SUM.BAT:

- 1) Copy temporary versions of the 90193005.ACS and 00193005.WEA files into the \TEMP directory.
- 2) Merge the data from these two files into one file (without duplicating time-stamp information) with the program COLS.COM and 901JOIN.AWK. COLS.COM is one of the helpful tool kits that comes with ARCHIVE. COLS.COM is used to copy the lines in the .ACS and .WEA files together (juxtaposition). It produces a temporary output file called .JUX.

```
C:\TEMP> COLS ^90193005.ACS ^00193005.WEA A B \TEMP\90193005.JUX
<enter>
```

This calls COLS.COM with the input files 90193005.ACS and 00193005.WEA. All columns in each file are merged together to form 90193005.JUX in the sub-directory \TEMP. 901JOIN.AWK then takes the .JUX file and removes redundant time-stamp information and performs calculations to reduce 3-phase electric power data into combined-phase data for each sub-metered load. The output of 901JOIN.AWK is a compact data file called .DAT.





**FIGURE A.18** Flow chart for 901SUM.BAT.

3) The .DAT extension is required because GRAPHER only takes files with the .DAT extension as input. For the input file, 90193005.ACS, the output file 90193005.DAT is created. Another batch file, MAKESPAC.BAT can be used to generate a second data file, SPCYYDDD.DAT, containing indoor ambient space conditions. This calls on AIR.EXE (AIR 1992) which takes indoor temperature and relative humidity data (found in the .ACS file) and derives several other psychrometric properties. This can only be done for the College Station store, where indoor ambient air conditions are monitored, and is not detailed here.

4) Call the GAWK script 901DATE.AWK to determine the beginning dates in the data set. This script automatically writes the batch file 901CHGRF.BAT.

5) Call 901CHGRF.BAT. This uses the GAWK script 901CHGRF.AWK and the dates found in 901DATE.AWK to change the .GRF files for each plot. These files need to be changed to start the time line (the X axis) at the correct spot for each week. As each GRAPHER file is modified, it is written into \TEMP.

6) For each .GRF file in \TEMP, call GRAPHER. The output is a device independent .PLT file.

7) Format each page. To print twelve graphs per page, the .PLT files need to be shrunk and "pasted" together. This is accomplished electronically with the insertion of a simple set of scale/translate files and the DOS copy command. The scale/translate files work as follows:

- SCALE.PLT: Shrink to about 30% of default GRAPHER output dimensions.
- A.PLT: Move to the lower left corner of page.
- B.PLT: Move up one row, the height of one plot.
- C.PLT: Move to the right X column (usually 1) and down three rows (usually) back to the bottom of the page.

The dimensions of translation may be changed to fit the number of plots desired and to fit the page orientation. A full page of plots (twelve for example, i.e., #1, #2, ...#12) is created by appending all of these together:

```
C:\TEMP> COPY SCALE.PLT + A.PLT + #1 + B.PLT + #2 + B.PLT + #3 + B.PLT + #4 +
C.PLT + #5 + B.PLT + #6 + B.PLT + #7 + B.PLT + #8 + C.PLT + #9 + B.PLT
+ #10 + B.PLT + #11 + B.PLT + #12. FULLPAGE.PLT <enter>
```

6) For each page of twelve graphs, use the GRAPHER PLOT program to create a Postscript .OUT file.

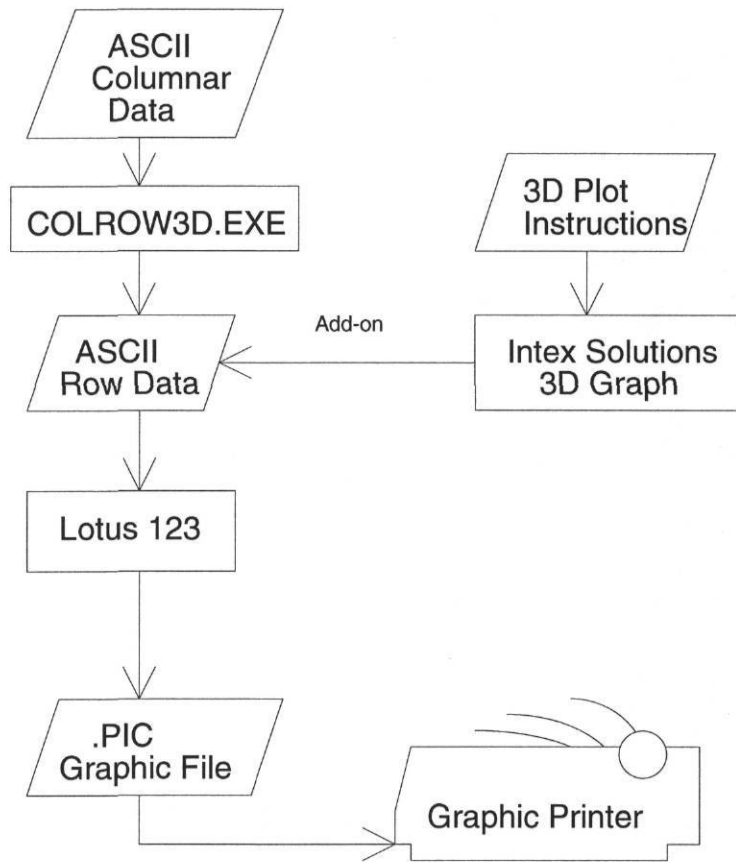
```
C:\TEMP> PLOT FULLPAGE.PLT <enter>
```

7) Clean out all the temporary files by deleting them.

#### **A.4.3 Creating a 3-D Graph Using Lotus 123 and Intex Solutions 3D Graph**

3-D graphs have been shown to be useful in displaying schedule-related whole-building and end-use energy profiles. However, it is not always easy to create useful 3-D plots on a PC because certain software packages require that data be placed in a special format prior to processing. The combination of software packages used to generate 3D plots for the College Station store is shown in Figure A.19. Columnar data are plotted with the Intex Solutions 3-D plot package that can be attached to Lotus 123 on a PC.

To facilitate the creation of 3-D plots a special routine was created to convert COLumnar data into ROW format to produce a 3D plot -- COLROW3D (1991). With this routine, two columns of ASCII data are fed to COLROW3D by which they are reformatted into a row-wise matrix to allow for importing into 123 for plotting with the 3-D graphics add-on package. To facilitate this easily in a batch mode previously compiled 3-D plot instructions can be used in a 123 macro file as shown in Figure A.19. Output from 123 consists of .PIC files that can be plotted or passed on to additional programs for further processing. This next section describes how to use the software to produce 3-D surface plots with the Lotus 123 add-on package that is available from Intex Solutions. The reader is referred to the Lotus 123 manual or the Intex Solutions 3-D graphics manual for further information about plotting the 3-D graphs.



**FIGURE A.19** Flow chart for producing 3-D plots.

### Using the COLROW3D Column-to-Row Data Processing Routine.

COLROW3D is a columnar data manipulation program which processes hourly energy consumption data to produce a "new" file containing a spread sheet compatible data matrix. COLROW3D compresses each day's worth of data into one row in the matrix. For example, a leap year's worth of hourly data (8784 lines) will be compressed down to just 367 lines!

The output file generated by COLROW3D can be used in conjunction with Lotus 123 and Intex Solution's 3D-Graphics add-on package to produce a three dimensional (3D) picture of energy consumption versus day of year and time of day. COLROW3D also creates a .LOG file containing information about the run and any erroneous data found.

**Input file(s).** The original energy consumption file contains two columns of data: Date (day of year and time of day expressed as a single decimal date string), and consumption (expressed in units between -999.9 and +9999.9). The data should be separated by a space from the decimal date and can be of real or integer type. The input file may contain up to 366 days of hourly data with each day containing 24 hours. All dates must be in chronological order. Table A.32 is a sample input file. When preparing the input file, keep in mind the following rules:

- *The input file may only contain numeric data of the integer and real type.* No characters other than the numerals 0 through 9, decimal points, minus signs, and spaces are allowed.
- *Each line row or record should contain only two data fields.* If more than two values are included, data beyond the second value are ignored. If only one datum is given on a line, the program will assume a missing value for the second field. A value of 0 is used as the missing code.
- *The maximum data that will be read are 366 days worth of hourly data.* Each day may contain from 1 to 24 hours of data--one record per hour. Only hourly data should be used as input to COLROW3D. Data in sub-hourly format must be converted to hourly format prior to processing.

TABLE A.32  
Example Input Data File For Colrow3d.

4704.0000	85.526
4704.0417	106.428
4704.0833	88.577
4704.1250	88.342
4704.1667	85.120
4704.2083	95.323
4704.2500	100.612
4704.2917	93.639
4704.3333	92.664
4704.3750	99.636
4704.4167	92.241
4704.4583	108.371

- The second data column in the input file can be any consumption environmental data. Acceptable values are between -999.9 and 9999.9. A value of 0 will be used for missing data. If the value lies outside the acceptable range, the program records an error message to the .LOG file, and sets the hourly consumption to 0 for missing data. Data are recorded to the output file by rounding off to the first decimal place.

**Time stamp.** COLROW3D requires a decimal time stamp. Arbitrarily, January 1, 1980 00:00:00 hours is considered to be "day 0" and has the decimal date representation 0000.0000. The number on the left hand side of the decimal point represents the number of days since January 1, 1980. The number on the right hand side of the decimal point represents the hour as a fraction of the day. Hours range from 0 through 23 and are calculated as the decimal portion multiplied by 24 and rounded to the nearest integer. Hour 24 becomes Hour 0 of the following day. Note, the day of the year must be in chronological order. No such requirement is imposed on the hour of the day.

Valid dates are from January 1, 1980 (day 0) through December 31, 2009 (day 10957). Leap years and century leap years are taken into consideration. The program will need to be updated for decimal dates beyond the year 2009. Table A.33 gives decimal dates for January 1 from 1980 through 2009. The following are examples of decimal date conversion,

Date	Time	Decimal date
January 21, 1988	11 p.m.	2942.9583
May 1, 1990	1 a.m.	3773.0417
December 31, 1991	5 p.m.	4382.7083

TABLE A.33  
Decimal Date Reference Table for COLROW3D.

January 1	Year	Dec.Date	# Days
January 1	1981.....	366 .....	365
January 1	1982.....	731 .....	365
January 1	1983.....	1096 .....	365
January 1	1984.....	1461 .....	366
January 1	1985.....	1827 .....	365
January 1	1986.....	2192 .....	365
January 1	1987.....	2557 .....	365
January 1	1988.....	2922 .....	366
January 1	1989.....	3288 .....	365
January 1	1990.....	3653 .....	365
January 1	1991.....	4018 .....	365
January 1	1992.....	4383 .....	366
January 1	1993.....	4749 .....	365
January 1	1994.....	5114 .....	365
January 1	1995.....	5479 .....	365
January 1	1996.....	5844 .....	366
January 1	1997.....	6210 .....	365
January 1	1998.....	6575 .....	365
January 1	1999.....	6940 .....	365
January 1	2000.....	7305 .....	366
January 1	2001.....	7671 .....	365
January 1	2002.....	8036 .....	365
January 1	2003.....	8401 .....	365
January 1	2004.....	8766 .....	366
January 1	2005.....	9132 .....	365
January 1	2006.....	9497 .....	365
January 1	2007.....	9862 .....	365
January 1	2008.....	10227.....	366
January 1	2009.....	10593.....	365

### Examples of Energy use data.

2901.0417	100	record indicates that on December 11, 1987 at 1:00 am the building used 100 kW of energy.
4020.0000	99999	ERROR! data value is out of bounds. A message will be written to the .LOG file, and the consumption will be set to 0.

**Output file(s).** The output data file contains the original energy use data which have been rearranged in a matrix format for use with Lotus 123. This file must have a .3D extension. The .LOG file contains information written by COLROW3D while the program is executed. Information regarding date and time of run, and any errors encountered during processing are included. The date of the first and last string of processed data are shown.

The output file is a N by 24 matrix containing only the valid input data. Here N stands for number of days between the first and last valid date stamp read from the input data file. For example, for one year's worth of data N is 366.

Both sample output files are shown in Table A.34. The first row is a header that contains the hour of the day (ranging from 0 to 23), the first column is the day of the year (for example, day 121 is May 1st), and the remaining fields are hourly consumption data (in units of kWh/h). Missing data are represented by the value -99. The very first value in the first row shows the day of year for the last date read. This makes it convenient to use the output file in a spreadsheet since it can be used to compute the number of rows in the table.



TABLE A.34  
An Example Output Data File For COLROW3D.

Method "0"							
0	0	1	2	3	.....	22	23
1	0.0	98.3	84.9	92.9	.....	100.4	99.9
2	94.6	101.9	86.5	95.5	.....	93.2	93.3
3	81.0	96.5	84.6	94.3	.....	99.1	100.7
4	99.9	103.7	85.0	95.0	.....	102.7	96.9
				:			
				:			
365	106.0	115.6	116.8	107.4	.....	106.3	105.0
366	97.4	107.3	111.5	103.3	.....	84.0	85.0
Method "1"							
3	0	1	2	3	.....	22	23
322	85.5	106.4	88.6	88.3	.....	102.0	104.6
323	98.7	118.7	99.5	102.6	.....	102.4	104.0
				:			
				:			
365	106.0	115.6	116.8	107.4	.....	106.3	105.0
1	81.5	86.8	92.6	82.2	.....	77.4	79.8
2	79.0	89.5	93.0	83.8	.....	86.3	82.7
3	83.7	93.8	98.5	89.6	.....	99.2	95.3
4	96.6	104.6	113.0	104.6	.....	75.1	75.4

**.LOG file.** COLROW3D keeps a record of what happened during each run of the program. This information is written to disk in a .LOG file. The .LOG file has the same name as the input data file, but with a .LOG extension. Existing .LOG files with the same name will be overwritten. Any errors encountered during execution are written to the .LOG file. An example of a .LOG file is shown in Table A.35.

The header specifies the name of the program and the date and time the run was made. The next line gives the name of the input file, the output file, the .LOG file, and the option selected. The following line gives the time the first record was read and the beginning date associated with that record.

The error table follows, and lists the location of the erroneous record, the data in the record, and the invalid datum. Since COLROW3D can deal with very

TABLE A.35  
An example .LOG file for COLROW3D.

```

Log of Colrow3D run Wed Apr 28 20:54:54 1993
Raw data file      : comp.dat
Colrow3D matrix file : COMP.3D
Log file          : COMP.LOG
Method used       : 0
First record read at 20:54:54          Begin Date : 4383.0415

          The following records were skipped
Record      Decimal Date      kWh/h data      Incorrect Value
-----
Last record read at 20:55:13          End Date : 4749.0000

Statistics :
No errors were found
Total number of records read and processed : 8784
Notice : Time values within a day are NOT checked for chronological order.

*** Error report completed. ***

```

large data files, a maximum of 50 date stamp errors and 20 data errors will be recorded in the .LOG file. This is to prevent a single bad datum from causing the entire data file to be written to the .LOG file. At the end of the error table is the time the last record was read and the ending date associated with that record.

The last part of the .LOG file consists of statistics about the input records. The .LOG file ends with a note, which states that the time portion of the date stamp is not checked for chronological order, and a message that the .LOG file is complete.

### Execution.

```
C:\TEMP> COLROW3D Input Output Option <enter>
```

*Input* is the input file name (with complete path and extension specified.)

*Output* is the processed data file (with .3D extension).

*Option* is the integer 0 or 1. Choose 0 to create a file beginning with days = 1 and ending with day = 366, each day containing 24 hours of data. If the original file has fewer than 366 days of data, missing data are set to 0. Select a value of 1 to

output fewer than one year's worth of data in contiguous order. Option 1 preserves the chronological order of input file. Figure A.20 illustrates the difference in 3-D graphs between a "0" and "1" option. Table A.34 shows the difference in the output files.

**Example.**

```
C:\TEMP> COLROW3D UTIL.DAT UTIL.3D 1 <enter>
```

*Action:* COLROW3D will read data from the input file called UTIL.DAT, output data to UTIL.3D, and create the .LOG file UTIL.LOG. Since the UTIL.DAT input file contains less than one year's worth of data, missing data are given the value of 0.

**Example.**

```
C:\TEMP> COLROW3D UTIL.DAT UTIL.3D 0 <enter>
```

*Action:* COLROW3D will read the file UTIL.DAT, output to the file UTIL.3D, and create the .LOG file UTIL.LOG. The output file is a 366 by 24 matrix with missing data set to 0.

**Example.**

```
C:\TEMP> COLROW3D ? <enter>
```

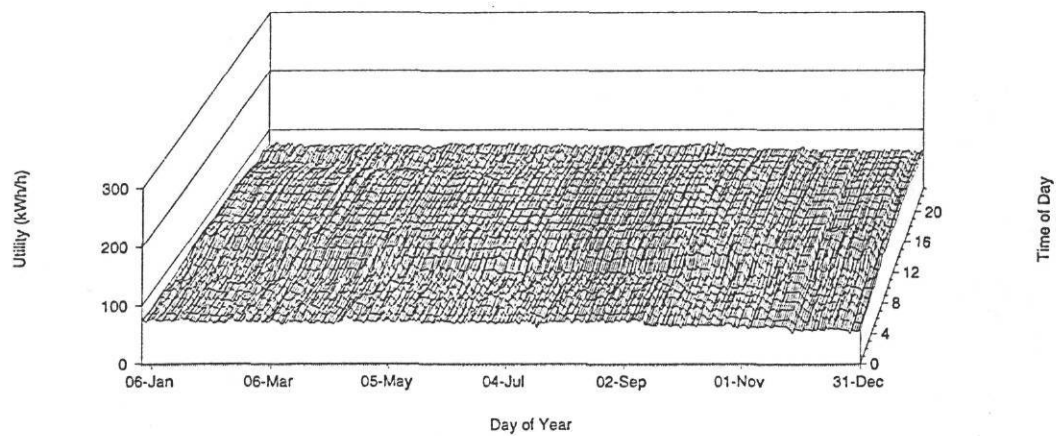
*Action:* COLROW3D displays the on-line help screen. For additional help, check the manual.

**Using Intex Solutions 3DGRAPH.** Table A.36 contains the 3DGRAPH plotting instructions that were used to produce the lower half at Figure A.20. This is a plot of the miscellaneous utility channel from the College Station grocery store. After installing, configuring, and initiating the Intex 3DGRAPH Lotus add-on, the UTIL.3D data matrix can be loaded with a FILE IMPORT command (with the pointer in cell A1). The graphing instructions can then be loaded after 3D Graph has been initiated with a GRAPH NAME USE command.

TABLE A.36  
 Intex Solutions 3DGRAPH Graphing Instructions for 3D Surface Plot

```

TYPE: SURFACE: HIDDEN
X B1..Y1
Y A2..A367
A B2..Y367
OPTIONS TITLE      FIRST: ""
                   SECOND: ""
                   X AXIS: "HOUR OF DAY"
                   Y AXIS: "DAY OF YEAR"
                   Z AXIS: "UTILITY (kWh/h)"
OPTIONS SCALE:     Z-SCALE: MANUAL: LOWER=0 UPPER=300
                   X-SKIP: 2
                   Y-SKIP: 60
OPTIONS: B&W
DISPLAY: ROTATION? 270
                VIEWPOINT? MEDIUM
                AXIS? YES
  
```



**Figure A.20**

*Example .PIC plots using the COLROW3D software package.*

## A.5 DATA-PROCESSING ROUTINES

This section lists the batch files, AWK scripts, and other miscellaneous instruction files mentioned in the previous sections and used to process the data.

### A.5.1 901SUM.BAT

```

rem /* 901sum.bat      version 1.0 1 Jan. 1993 */
rem /*****
rem * Copyright (c) 1993, Texas Engineering Experiment Station
rem *
rem * Program: 901sum.bat
rem * Version: 1.0
rem * Last Update: 1/1/93
rem *
rem * DESCRIPTION: This batch script produces the summary plots for the
rem *               College Station grocery store, site 901.
rem *
rem * HISTORY:
rem *   Design: R.L. Cox
rem *   Code: R.L. Cox
rem *
rem * MODIFICATIONS:
rem *   NAME:           DATE:       VERSION:  DESCRIPTION:
rem *
rem * HISTORY AND DISTRIBUTION RIGHTS
rem *   DEVELOPED BY: Energy Systems Laboratory, Mechanical Engr. Dept.,
rem *               Texas A & M Univ., College Station, Texas 77843-3123,
rem *               (409) 845-1560
rem *   SUPPORTED BY: State of Texas Governor's Energy Management Center
rem *
rem * COPYRIGHT NOTICE: This program bears a copyright notice to prevent rights
rem *                   from being claimed by any other party. Texas A & M University intends
rem *                   that the program be placed in the public domain and grants permission
rem *                   for it to be used and redistributed, provided that:
rem *                   1) the source code is distributed,
rem *                   2) this notice is retained in all copies of the source code, and
rem *                   3) the program is not sold for profit without written approval
rem *                   from TEES.
rem *
rem *   The program is distributed "as is". TEES provides no warranty or
rem *   support service unless special arrangements have been made to do so.
rem *   Certain manufacturers and trade names are mentioned in this code for
rem *   the purpose of describing their communications protocol. This does
rem *   not constitute an endorsement or recommendation of such equipment,
rem *   but is provided for informational purposes only.
rem *
rem *****/

@rem 901SUM.BAT
@echo off

echo Processing submetered data for Kroger (Site 901)
if "%2"==" " goto error

echo I expect the original 901%1%2.dat file to be in the \work\dat\ directory!

```

```
echo -----
copy \work\dat\901%1%2.dat \temp\901week.dat > nul
copy \work\dat\spc%1%2.dat \temp\901space.dat > nul
copy \work\bud\t901*.src \temp\*.grf > nul

gawk -f \work\util\901date.awk \work\dat\901%1%2.dat > \work\util\901chgrf.bat
gawk -f \work\util\901date8.awk \work\dat\901%1%2.dat > \work\util\901cgrf8.bat

cd \work\bud

rem These lines work on .src files in \work\bud.
rem Specialised .grf files are written to the \temp\ directory

call \work\util\901chgrf t901_02 src
call \work\util\901chgrf t901_03 src
call \work\util\901chgrf t901_05 src
call \work\util\901chgrf t901_06 src
call \work\util\901cgrf8 t901_08 src
call \work\util\901chgrf t901_09 src
call \work\util\901chgrf t901_11 src
call \work\util\901chgrf t901_12 src
call \work\util\901chgrf t901_13 src
call \work\util\901chgrf t901_14 src
call \work\util\901chgrf t901_15 src
call \work\util\901chgrf t901_16 src
call \work\util\901chgrf t901_17 src
call \work\util\901chgrf t901_22 src

cd\temp
echo -----
echo Generating .plt files

grapher t901_01.grf
echo.
grapher t901_02.grf
echo.
grapher t901_03.grf
echo.
grapher t901_04.grf
echo.
grapher t901_05.grf
echo.
grapher t901_06.grf
echo.
grapher t901_07.grf
echo.
grapher t901_08.grf
echo.
grapher t901_09.grf
echo.
grapher t901_10.grf
echo.
grapher t901_11.grf
echo.
grapher t901_12.grf
echo.
grapher t901_13.grf
echo.
grapher t901_14.grf
echo.
grapher t901_15.grf
echo.
grapher t901_16.grf
echo.
grapher t901_17.grf
echo.
grapher t901_18.grf
echo.
grapher t901_19.grf
echo.
grapher t901_20.grf
echo.
grapher t901_21.grf
echo.
```

```

grapher t901_22.grf
echo.

@echo off

copy \work\util\a.plt + t901_12.plt + \work\util\b.plt + t901_09.plt part1.plt > nul
copy \work\util\b.plt + t901_06.plt + \work\util\b.plt + t901_03.plt part2.plt > nul
copy \work\util\d.plt + t901_02.plt + \work\util\b.plt + t901_05.plt part3.plt > nul
copy \work\util\b.plt + t901_08.plt + \work\util\b.plt + t901_11.plt part4.plt > nul
copy \work\util\d.plt + t901_01.plt + \work\util\b.plt + t901_04.plt part5.plt > nul
copy \work\util\b.plt + t901_07.plt + \work\util\b.plt + t901_10.plt part6.plt > nul

copy part1.plt + part2.plt + part3.plt + part4.plt tem1.tem > nul
copy part5.plt + part6.plt tem2.tem > nul

copy \work\util\scale.plt + tem1.tem + tem2.tem 901sum1.plt > nul

copy \work\util\a.plt + t901_16.plt + \work\util\b.plt + t901_15.plt part7.plt > nul
copy \work\util\b.plt + t901_14.plt + \work\util\b.plt + t901_13.plt part8.plt > nul
copy \work\util\d.plt + \work\util\b.plt part9.plt > nul
copy \work\util\b.plt + t901_22.plt + \work\util\b.plt + t901_17.plt parta.plt > nul
copy \work\util\d.plt + t901_21.plt + \work\util\b.plt + t901_20.plt partb.plt > nul
copy \work\util\b.plt + t901_19.plt + \work\util\b.plt + t901_18.plt partc.plt > nul

copy part7.plt + part8.plt + part9.plt + parta.plt tem1.tem > nul
copy partb.plt + partc.plt tem2.tem > nul

copy \work\util\scale.plt + tem1.tem + tem2.tem 901sum2.plt > nul

echo Complete
echo -----

rem goto skip

view \temp\901sum1.plt
view \temp\901sum2.plt

echo If these plots are satisfactory, press any key to continue with plotting...
pause > nul

:skip

echo Creating Postscript file #1
plot 901sum1.plt /b

echo Creating Postscript file #2
plot 901sum2.plt /b

@echo off
echo Cleaning
cd \temp
del *.tem > nul
del part?.plt > nul

goto done

:error
echo Usage: 901sum YY DDD

:done

rem Print the output files to the printer
copy 901sum1.out lpt1
copy 901sum2.out lpt1

echo Processing completed for Kroger-CS (Site 901)

cd \work\bud

```

## A.5.2 901JOIN.BAT

```

rem /* 901join.bat version 1.0 1 Jan. 1993 */
rem /*****
rem * Copyright (c) 1993, Texas Engineering Experiment Station
rem *
rem * Program: 901join.bat
rem * Version: 1.0
rem * Last Update: 1/1/93
rem *
rem * DESCRIPTION: This batch script produces the data files 901yyddd.dat
rem *               for the College Station grocery store, site 901.
rem *
rem *
rem * HISTORY:
rem *   Design: R.L. Cox
rem *   Code: R.L. Cox
rem *
rem * MODIFICATIONS:
rem *   NAME:           DATE:           VERSION:  DESCRIPTION:
rem *
rem * HISTORY AND DISTRIBUTION RIGHTS
rem *   DEVELOPED BY: Energy Systems Laboratory, Mechanical Engr. Dept.,
rem *                 Texas A & M Univ., College Station, Texas 77843-3123,
rem *                 (409) 845-1560
rem *   SUPPORTED BY: State of Texas Governor's Energy Management Center
rem *
rem * COPYRIGHT NOTICE: This program bears a copyright notice to prevent rights
rem *                   from being claimed by any other party. Texas A & M University intends
rem *                   that the program be placed in the public domain and grants permission
rem *                   for it to be used and redistributed, provided that:
rem *                   1) the source code is distributed,
rem *                   2) this notice is retained in all copies of the source code, and
rem *                   3) the program is not sold for profit without written approval
rem *                   from TEES.
rem *                   The program is distributed "as is". TEES provides no warranty or
rem *                   support service unless special arrangements have been made to do so.
rem *                   Certain manufacturers and trade names are mentioned in this code for
rem *                   the purpose of describing their communications protocol. This does
rem *                   not constitute an endorsement or recommendation of such equipment,
rem *                   but is provided for informational purposes only.
rem *
rem * *****/

@rem          901JOIN.BAT
@echo off
echo usage: 901join YY DDD
echo where, YY is the year and DDD is the julian date

if "%1"==" " goto done

echo Working on week polled on date %1%2
echo I expect to find the .acs and .wea files in the \work\acs\ directory
echo -----
echo Joining "901%1%2.acs" and "001%1%2.wea" into "\work\dat\901%1%2.jux"

@echo The T and RH signals at 901 are now included as columns 23 and 24 in the

```



```

@echo 901yyddd.acs file.  They are placed as the last two columns in the JUX file.

cols ^\work\acs\901%1%2.acs ^\work\acs\001%1%2.wea a1:22 b1:12 a23:24
v\work\dat\901%1%2.jux

echo Gawking file \work\dat\901%1%2.jux
cd \work\dat
gawk -f \work\util\901join.awk \work\dat\901%1%2.jux > output.dat
copy output.dat \work\dat\901%1%2.dat

del output.dat

call makespac.bat %1 %2

cd \work\acs

:done

echo Done

```

### A.5.3 901JOIN.AWK

```

# /* 901sum.awk          version 1.0 1 Jan. 1993 */
# /*****
# * Copyright (c) 1993, Texas Engineering Experiment Station
# *
# * Program: 901sum.awk
# * Version: 1.0
# * Last Update: 1/1/93
# *
# * DESCRIPTION: This AWK script produces the *.DAT data file for the
# *               College Station grocery store, site 901.
# *
# * HISTORY:
# *   Design: R.L. Cox
# *   Code: R.L. Cox
# *
# * MODIFICATIONS:
# *   NAME:           DATE:           VERSION:  DESCRIPTION:
# *
# * HISTORY AND DISTRIBUTION RIGHTS
# *   DEVELOPED BY: Energy Systems Laboratory, Mechanical Engr. Dept.,
# *                 Texas A & M Univ., College Station, Texas 77843-3123,
# *                 (409) 845-1560
# *   SUPPORTED BY: State of Texas Governor's Energy Management Center
# *
# * COPYRIGHT NOTICE: This program bears a copyright notice to prevent rights
# *                   from being claimed by any other party.  Texas A & M University intends
# *                   that the program be placed in the public domain and grants permission
# *                   for it to be used and redistributed, provided that:
# *                   1) the source code is distributed,
# *                   2) this notice is retained in all copies of the source code, and
# *                   3) the program is not sold for profit without written approval
# *                   from TEES.
# *
# * The program is distributed "as is".  TEES provides no warranty or
# * support service unless special arrangements have been made to do so.
# * Certain manufacturers and trade names are mentioned in this code for

```

```

# *      the purpose of describing their communications protocol. This does
# *      not constitute an endorsement or recommendation of such equipment,
# *      but is provided for informational purposes only.
# *
# *****/

# This is 901JOIN.AWK,
# a script which takes an ACS file prepared with
# 901JOIN.BAT and adds appropriate columns to produce 901yyddd.DAT

{
tempdb = $29;
rh = $30;
sol = $33;
enth = $31;
w = $32;
wind = $34;
temp_RA = $35;
rh_RA = $36;

# COMPressor channel. Must subtract video store HVAC
# from the raw COMP channels.

if(($8>=0)&&($9>=0)&&($10>=0)&&($20>=0)&&($21>=0)&&($22>=0))
{compr = 0 + ($8 + $9 + $10) - ($20 + $21 + $22);}
else
if(($8>=0)&&($9>=0)&&($10>=0))
{compr = 0 + ($8 + $9 + $10);}
else
{compr = -99;}

# Combined LGHTing channel.
if(($11>=0)&&($12>=0)&&($13>=0))
{lght = 0 + $11 + $12 + $13;}
else
{lght = -99;}

# Combined HVAC channel.
if(($14>=0)&&($15>=0)&&($16>=0)&&($20>=0)&&($21>=0)&&($22>=0))
{hvac = 0 + $14 + $15 + $16 + $20 + $21 + $22;}
else
if(($14>=0)&&($15>=0)&&($16>=0))
{hvac = 0 + $14 + $15 + $16;}
else
{hvac = -99;}

# Combined miscellaneous utility.
if(($17>=0)&&($18>=0)&&($19>=0))
{util = 0 + $17 + $18 + $19;}
else
{util = -99;}

# Combined video HVAC.
if(($20>=0)&&($21>=0)&&($22>=0))
{vid = 0 + $20 + $21 + $22;}
else
{vid = -99;}

# Whole building energy use (kwh/h)

if((compr>=0)&&(lght>=0)&&(hvac>=0)&&(util>=0))
{whole = 0 + compr + lght + hvac + util;}
else
{whole = -99;}

print $1,$2,$3,$4,$5,$6,$7,compr,lght,hvac,
      util,vid,whole,tempdb,rh,sol,enth,w,wind,temp_RA,rh_RA;
}

```

### A.5.4 901CHGRF.AWK

```

# /* 901CHGRF.AWK      version 1.0 1 Jan. 1993 */
# /*****
# * Copyright (c) 1993, Texas Engineering Experiment Station
# *
# * Program: 901CHGRF.AWK
# * Version: 1.0
# * Last Update: 1/1/93
# *
# * DESCRIPTION: This AWK script alters the .GRF file to include the correct
# *               date of the week being processed for the
# *               College Station grocery store, site 901.
# *
# * HISTORY:
# *   Design: R.L. Cox
# *   Code: R.L. Cox
# *
# * MODIFICATIONS:
# *   NAME:           DATE:           VERSION:  DESCRIPTION:
# *
# * HISTORY AND DISTRIBUTION RIGHTS
# *   DEVELOPED BY: Energy Systems Laboratory, Mechanical Engr. Dept.,
# *                 Texas A & M Univ., College Station, Texas 77843-3123,
# *                 (409) 845-1560
# *   SUPPORTED BY: State of Texas Governor's Energy Management Center
# *
# * COPYRIGHT NOTICE: This program bears a copyright notice to prevent rights
# *                   from being claimed by any other party. Texas A & M University intends
# *                   that the program be placed in the public domain and grants permission
# *                   for it to be used and redistributed, provided that:
# *                   1) the source code is distributed,
# *                   2) this notice is retained in all copies of the source code, and
# *                   3) the program is not sold for profit without written approval
# *                   from TEES.
# *
# *   The program is distributed "as is". TEES provides no warranty or
# *   support service unless special arrangements have been made to do so.
# *   Certain manufacturers and trade names are mentioned in this code for
# *   the purpose of describing their communications protocol. This does
# *   not constitute an endorsement or recommendation of such equipment,
# *   but is provided for informational purposes only.
# *
# * *****/
{
  gsub(/Site 901 Beginning/, "Site 901 Beginning " var1);
  if (NR == 12) printf("%f %f %s %s %s \n", var2, var2+7, $3, $4, $5);
  else print$0;
}

```

### A.5.5 901CGRF8.AWK

```

# /* 901CGRF8.AWK      version 1.0 1 Jan. 1993 */
# /*****

```

```

# * Copyright (c) 1993, Texas Engineering Experiment Station
# *
# * Program: 901CGRF8.AWK
# * Version: 1.0
# * Last Update: 1/1/93
# *
# * DESCRIPTION: This AWK script alters the .GRF file to include the correct
# *               date of the week being processed for the
# *               College Station grocery store, site 901. It is a variation
# *               of 901CHGRF.AWK, handling a .GRF file which has two input
# *               .DAT files.
# * HISTORY:
# *   Design: R.L. Cox
# *   Code: R.L. Cox
# *
# * MODIFICATIONS:
# *   NAME:           DATE:           VERSION:  DESCRIPTION:
# *
# * HISTORY AND DISTRIBUTION RIGHTS
# *   DEVELOPED BY: Energy Systems Laboratory, Mechanical Engr. Dept.,
# *                 Texas A & M Univ., College Station, Texas 77843-3123,
# *                 (409) 845-1560
# *   SUPPORTED BY: State of Texas Governor's Energy Management Center
# *
# * COPYRIGHT NOTICE: This program bears a copyright notice to prevent rights
# *                   from being claimed by any other party. Texas A & M University intends
# *                   that the program be placed in the public domain and grants permission
# *                   for it to be used and redistributed, provided that:
# *                   1) the source code is distributed,
# *                   2) this notice is retained in all copies of the source code, and
# *                   3) the program is not sold for profit without written approval
# *                   from TEES.
# *
# *   The program is distributed "as is". TEES provides no warranty or
# *   support service unless special arrangements have been made to do so.
# *   Certain manufacturers and trade names are mentioned in this code for
# *   the purpose of describing their communications protocol. This does
# *   not constitute an endorsement or recommendation of such equipment,
# *   but is provided for informational purposes only.
# *
# * *****/
# {
#   gsub(/Site 901 Beginning/, "Site 901 Beginning " var1);
#   if (NR == 19) printf("%f %f %s %s %s \n", var2, var2+7, $3, $4, $5);
#   else print$0;
# }

```

## A.5.6 901DATE.AWK

```

# /* 901DATE.AWK      version 1.0 1 Jan. 1993 */
# /*****
# *   Copyright (c) 1993, Texas Engineering Experiment Station
# *
# *   Program: 901DATE.AWK
# *   Version: 1.0
# *   Last Update: 1/1/93
# *
# *   DESCRIPTION:
# /* This AWK script gets the date string (mm-dd-yyyy) and decimal date (xxxx) */
# /* from the *.acs file being processed. */
# /* The output from this file is a command string which will change the date */
# /* in X-Axis label and also change the starting value */
# *
# *   HISTORY:
# *       Design: R.L. Cox
# *       Code: R.L. Cox
# *
# *   MODIFICATIONS:
# *       NAME:           DATE:       VERSION:  DESCRIPTION:
# *
# *   HISTORY AND DISTRIBUTION RIGHTS
# *       DEVELOPED BY: Energy Systems Laboratory, Mechanical Engr. Dept.,
# *                   Texas A & M Univ., College Station, Texas 77843-3123,
# *                   (409) 845-1560
# *       SUPPORTED BY: State of Texas Governor's Energy Management Center
# *
# *   COPYRIGHT NOTICE: This program bears a copyright notice to prevent rights
# *                       from being claimed by any other party. Texas A & M University intends
# *                       that the program be placed in the public domain and grants permission
# *                       for it to be used and redistributed, provided that:
# *                       1) the source code is distributed,
# *                       2) this notice is retained in all copies of the source code, and
# *                       3) the program is not sold for profit without written approval
# *                           from TEES.
# *
# *       The program is distributed "as is". TEES provides no warranty or
# *       support service unless special arrangements have been made to do so.
# *       Certain manufacturers and trade names are mentioned in this code for
# *       the purpose of describing their communications protocol. This does
# *       not constitute an endorsement or recommendation of such equipment,
# *       but is provided for informational purposes only.
# *
# *   *****/
NR == 1 {
  var1 = $2-"-$3"-19"$4;
  var2 = " \\work\\util\\901chgrf.awk ";
  var3 = " %1.src ";
  var4 = " >\\temp\\%1.grf ";
  printf ("gawk -v var1=%s -v var2=%d -f %s %s %s %s \n",var1,$6,var2,var3,var4);
}

```

## A.5.7 901DATE8.AWK

```

# /* 901DATE8.AWK      version 1.0 1 Jan. 1993 */
# /*****
# * Copyright (c) 1993, Texas Engineering Experiment Station
# *
# * Program: 901DATE8.AWK
# * Version: 1.0
# * Last Update: 1/1/93
# *
# * DESCRIPTION:
# /* This AWK script gets the date string (mm-dd-yyyy) and decimal date (xxxx) */
# /* from the *.acs file being processed. */
# /* The output from this file is a command string which will change the date */
# /* in X-Axis label and also change the starting value */
# *
# * HISTORY:
# *   Design: R.L. Cox
# *   Code: R.L. Cox
# *
# * MODIFICATIONS:
# *   NAME:           DATE:       VERSION:  DESCRIPTION:
# *
# * HISTORY AND DISTRIBUTION RIGHTS
# *   DEVELOPED BY: Energy Systems Laboratory, Mechanical Engr. Dept.,
# *                 Texas A & M Univ., College Station, Texas 77843-3123,
# *                 (409) 845-1560
# *   SUPPORTED BY: State of Texas Governor's Energy Management Center
# *
# * COPYRIGHT NOTICE: This program bears a copyright notice to prevent rights
# * from being claimed by any other party. Texas A & M University intends
# * that the program be placed in the public domain and grants permission
# * for it to be used and redistributed, provided that:
# *   1) the source code is distributed,
# *   2) this notice is retained in all copies of the source code, and
# *   3) the program is not sold for profit without written approval
# *      from TEES.
# *
# * The program is distributed "as is". TEES provides no warranty or
# * support service unless special arrangements have been made to do so.
# * Certain manufacturers and trade names are mentioned in this code for
# * the purpose of describing their communications protocol. This does
# * not constitute an endorsement or recommendation of such equipment,
# * but is provided for informational purposes only.
# *
# *****/
NR == 1 {
var1 = $2-"$3"-19"$4;
var2 = " \\work\\util\\901cgrf8.awk ";
var3 = " %1.src ";
var4 = " >\\temp\\%1.grf ";
printf ("gawk -v var1=%s -v var2=%d -f %s %s %s %s %s\n",var1,$6,var2,var3,var4);
}

```

## A.5.8 MAKESPAC.BAT

```
rem /* MAKESPAC.BAT      version 1.0 1 Jan. 1993 */
```

```

rem /*****
rem * Copyright (c) 1993, Texas Engineering Experiment Station
rem *
rem * Program: MAKESPAC.BAT
rem * Version: 1.0
rem * Last Update: 1/1/93
rem *
rem * DESCRIPTION: This batch script produces the space condition data file
rem *                SPCyyddd.DAT for the College Station grocery store, site 901.
rem *
rem * HISTORY:
rem *     Design: R.L. Cox
rem *     Code: R.L. Cox
rem *
rem * MODIFICATIONS:
rem *     NAME:                DATE:        VERSION:  DESCRIPTION:
rem *
rem * HISTORY AND DISTRIBUTION RIGHTS
rem *     DEVELOPED BY: Energy Systems Laboratory, Mechanical Engr. Dept.,
rem *                Texas A & M Univ., College Station, Texas 77843-3123,
rem *                (409) 845-1560
rem *     SUPPORTED BY: State of Texas Governor's Energy Management Center
rem *
rem * COPYRIGHT NOTICE: This program bears a copyright notice to prevent rights
rem *                    from being claimed by any other party. Texas A & M University intends
rem *                    that the program be placed in the public domain and grants permission
rem *                    for it to be used and redistributed, provided that:
rem *                    1) the source code is distributed,
rem *                    2) this notice is retained in all copies of the source code, and
rem *                    3) the program is not sold for profit without written approval
rem *                    from TEES.
rem *
rem *                    The program is distributed "as is". TEES provides no warranty or
rem *                    support service unless special arrangements have been made to do so.
rem *                    Certain manufacturers and trade names are mentioned in this code for
rem *                    the purpose of describing their communications protocol. This does
rem *                    not constitute an endorsement or recommendation of such equipment,
rem *                    but is provided for informational purposes only.
rem *
rem * *****/
@echo off

if "%2"==" " goto usage
if "%3"=="-SI" goto SI

:english
echo English units chosen...
echo { > tem.awk
echo   printf("%%7.2f %%7.2f\n", $20, $21 ); >> tem.awk
echo } >> tem.awk
goto skip

:SI
echo SI units chosen...
echo { > tem.awk
echo   printf("%%7.2f %%7.2f\n", (($20+460.0)*5/9-273.0), $21 ); >> tem.awk
echo } >> tem.awk

:skip

```

```
echo Gawking
gawk -f tem.awk 901%1%2.dat > tem.out

echo Running air %3
air %3 tem.out air.out 3

cols ^901%1%2.dat ^air.out a1:7 a10 a14:21 b > spc%1%2.dat

del tem.out > nul
del air.out > nul
del tem.awk > nul

:usage
echo Usage: makespac yy ddd [-SI]
```

## A.5.9 .PLT FILES

### SCALE.PLT

```
SC .25 .25
```

### A.PLT

```
TR 2. 2.
```

### B.PLT

```
TR 0 8.5
```

### C.PLT

```
TR 8.3 -17.0
```

### D.PLT

```
TR 8.3 -25.5
```



## APPENDIX B

## BUILDING ENERGY USE SURVEY DATA

TABLE B.1  
College Station Store Miscellaneous Utilities  
Nameplate Rating Loads

Deli/Bakery:	Qty	Amps /ph	Volts	kW in	phase	hp	Notes
Bake King Fryer	1	27	208	8.50	3		
Bake King Filter	1	3.4	208	0.80	1		
BBQ King Fryer	1	48	208	12.10	3		
BBQ King Filter	1	3.4	208	0.80	1		
Hobart Oven	1			15.60	3		
Hobart Oven	1			15.60	3		
Bread Retarder	1			0.63			
Ice Machine	1	13.43	120	1.21	1		pf = 0.75
Bread Proofer	1		208	13.40			Baker's Aid Inc. BAPIS-1D-S5
Bread Proofer	1		208	13.40			Baker's Aid Inc. BAPIS-1D-S5
Meat Saw	1	5.5	120	0.50	0.33		pf = 0.75
Meat Saw	1	5.5	120	0.50	0.33		pf = 0.75
Cheese Island Slicer	1	5.2	120	0.47	0.33		pf = 0.75
Steam Warmer	7	10	120	8.40	1		
Saran Wrapper	1		120	1.30			
Fry Plate Stove	1	32.5	208	3.90	1		
Small Condiments Refr.	1	8.8	208	0.79	1		pf = 0.75
Coffee Brewer	1	2	120	2.20			
Microwave 1	1			1.10			
Blender 1	1	8.2	120	0.74			pf = 0.75
Bread Slicer 1	1	6.2	120	0.56		0.33	pf = 0.75
Hobart Scale 1	1	1.3	120	0.15			
Hobart Scale 1	1	1.3	120	0.15			
Hobart Scale 1	1	1.3	120	0.15			
Total:				102.9			

TABLE B.1  
College Station Store Miscellaneous Utilities  
Nameplate Rating Loads (continued)

## Meat Preparation:

	Qty	Amps /ph	Volts	kW in	phase	hp	Notes
Band Saw	1	14.6	120	1.32	1	1.50	pf = 0.75
Band Saw	1	14.6	120	1.32	1	1.50	pf = 0.75
Meat Mill	1	19.5	120	1.76	1	2.00	pf = 0.75
Packager	1	12.0	120	1.08	1	1.23	
Hobart Scale	1	1.3	120	0.15	1		
Hobart Scale	1	1.3	120	0.15	1		
Meat Slicer	1	5.2	120	0.47	1	0.33	

Total: 6.24

## Cash Registers (on Lightng Circuit)

	Qty	Amps /ph	Volts	kW in	phase	hp	Notes
Check Stand	1	5	115	0.58	1		
Check Stand	1	5	115	0.58	1		
Check Stand	1	5	115	0.58	1		
Check Stand	1	5	115	0.58	1		
Check Stand	1	5	115	0.58	1		
Check Stand	1	5	115	0.58	1		
Check Stand	1	5	115	0.58	1		
Check Stand	1	5	115	0.58	1		
Check Stand	1	5	115	0.58	1		
Check Stand	1	5	115	0.58	1		
Check Stand	1	5	115	0.58	1		
Check Stand	1	5	115	0.58	1		
Camera Bar Register	1	2	115	0.23	1		
Deli Register	1	2	115	0.23	1		

Total: 6.79

TABLE B.1  
College Station Store Miscellaneous Utilities  
Nameplate Rating Loads (continued)

Other:							
	Qty	Amps /ph	Volts	kW in	phase	hp	Notes
Trash Baler	1			8.57	3	10	pf = 0.76, eff = 0.87 known pf = 0.66, 100 kW peak defrost
Case & Cooler Fans	---	---	115	29.9	1		
Total for Utility Loads (not inc. Cash Registers):				147.6			
Compressor Room Fans (on compressor circuit):							
	Qty	Amps /ph	Volts	kW in	phase	hp	Notes
Exhaust Fan	1	18	208	5.51	3	6	pf = 0.85
Exhaust Fan	1	18	208	5.51	3	6	
Exhaust Fan	1	18	208	5.51	3	6	
Exhaust Fan	1	18	208	5.51	3	6	
Total:				22.05			

TABLE B.2  
College Station Store Lighting Count

Use Code	Luminaires	Lamps/ Lumin.	Watts/ lamp	Ballast Factor	Total Watts	Location
c	4	2	60	1.1	528	Butcher Case
c	8	1	40	1.1	352	Floral
c	4	1	60	1.1	264	Floral Mum Case
c	2	1	40	1.1	88	Fresh Chilled Juice Case
c	2	1	85	1.1	187	Health & Floral Case
c	2	1	40	1.1	88	Ice Bunker
c	6	2	100	1.1	1320	Ice Cream Cases
c	4	1	85	1.1	374	Milk Case
c	12	1	100	1.1	1320	OJ & Egg Cases
c	7	2	75	1.1	1155	Poultry Case (drop ceil)
c	12	1	40	1.1	528	Produce Wall
c	9	1	40	1.1	396	Produce Wall
c	12	1	85	1.1	1122	3 DK Red Meat Case
c	12	2	40	1.1	1056	Salad Bar
c	8	1	100	1.1	880	Sausage & Meats Decks
c	30	1	60	1.1	1980	Sausage & Meats Decks
c	6	1	60	1.1	396	Sausage & Meats Decks
c	4	2	60	1.1	528	Seafood Case
c	2	1	40	1.1	88	Wine Cooler Case
c	2	1	40	1.1	88	Yogurt Case
NL	2	1	230		460	Deli & Cosm. Registers
NL	1	1	1200		1200	Ice Machine
NL	11	1	580		6380	POS Cash Registers
NL	1	1	172		172	Yogurt Machine
og	14	2	75	1.1	2310	Back Room
og	5	2	40	1.1	440	Back Room
og	3	2	40	1.1	264	Break Room Mezzanine
og	3	2	40	1.1	264	Compressor Mezzanine
og	1	2	40	1.1	88	Computer Room
og	4	2	85	1.1	748	Dairy Cooler Room
og	2	1	85	1.1	187	Floral Cooler
og	3	2	75	1.1	495	General Offices
og	5	1	75	1.1	412.5	Loading Dock
og	1	2	40	1.1	88	Loading Dock
og	2	2	40	1.1	176	Mail and Timer Rooms
og	2	2	75	1.1	330	Manager's Office
og	2	1	85	1.1	187	Meat Freezer 1
og	1	2	60	1.1	132	Meat Freezer 1
og	1	1	85	1.1	93.5	Meat Freezer 2
og	5	1	85	1.1	467.5	Meat Prep
og	6	2	85	1.1	1122	Meat Prep Back Room

TABLE B.2a  
Store Lighting Count (continued)

Use Code	Luminaires	Lamps/ Lumin.	Watts/ lamp	Ballast Factor	Total Watts	Location	
og		2	2	60	1.1	264	Meat Prep Back Room
og		2	2	40	1.1	176	Men's Room
og		9	1	75	1.1	742.5	Outside Porch Lights
og		6	2	75	1.1	990	Produce Prep
og		1	2	75	1.1	165	Restroom Hallway
og		1	2	75	1.1	165	Stairwell
og		2	2	40	1.1	176	Women's Room
og*		11	1	100	1	1100	Check Stand Sign Lamps
og*		26	1	175	1.2	5460	Checkstands
og*		8	1	175	1.2	1680	Cheese Island
og*		1	2	40	1.1	88	Deli Black Light Traps
og*		6	1	100	1	600	Snack Bar
og*		1	2	40	1.1	88	Vestibule Light Traps
os		10	4	40	1.1	1760	Pharmacy
os		2	2	40	1.1	176	Deli
os		6	4	40	1.1	1056	Drugs
os		4	2	40	1.1	352	Drugs
os		9	2	40	1.1	792	Bakery
os		19	2	40	1.1	1672	Bakery/Deli Drop Ceil
os		3	2	75	1.1	495	Butcher Area
os		12	2	75	1.1	1980	Cheese Overhead
os		6	2	40	1.1	528	Cheese Overhead
os		25	2	75	1.1	4125	Beer/Wine Overhead
os		5	2	40	1.1	440	Beer/Wine Overhead
os		16	2	75	1.1	2640	Dairy Overhead
os		3	2	40	1.1	264	Dairy Overhead
os		230	2	75	1.1	37950	Main Rect Sect
os		34	2	75	1.1	5610	Produce Overhead
os		3	2	40	1.1	264	Produce Overhead
os		17	2	75	1.1	2805	Check-out Overhead
os		2	2	40	1.1	176	Check-out Overhead
os		10	4	40	1.1	1760	Customer Service Ovrhd
os		7	2	40	1.1	616	Ice Bunker Overhead
os*		24	1	175	1.2	5040	Produce Islands
p		20	1	110	1.1	2420	Cube Sign
p		8	3	8	1.1	211.2	Wall Signs (non-"curly")
p		8	2	1000	1.25	20000	Parking Lot
p		4	1	1000	1.25	5000	Rear Parking Lot

TABLE B.2a  
Store Lighting Count (continued)

Use Code	Luminaires	Lamps/ Lumin.	Watts/ lamp	Ballast Factor	Total Watts	Location
r	1	1	40	1.1	44	Bakery End Cap
r	8	1	40	1.1	352	Bakery Racks
r	1	1	40	1.1	44	Bakery Racks
r	4	1	75	1.1	330	Bakery Racks
r	8	2	75	1.1	1320	Bread Racks
r	1	2	40	1.1	88	Bread Racks
r	8	2	75	0.1	120	Bread Racks (OFF)
r	1	2	40	1.1	88	Coffee Station Rack
r	12	2	40	1.1	1056	Cosmetics Rack
r	5	2	40	1.1	440	Cosmetics Rack
r	6	1	40	1.1	264	Doughnut Case
r	34	1	40	1.1	1496	Greeting Cards Racks
r	3	2	40	1.1	264	Health Foods Racks
r	1	1	40	1.1	44	Magazine Rack (end cap)
r	9	1	40	1.1	396	Magazine Racks
r	10	1	40	1.1	440	Magazine Racks
r	9	1	40	1.1	396	Photo Bar
r	19	2	40	1.1	1672	Soda Racks (Drop Ceil)
v	4	2	75	1.1	660	Video Store Back Rooms
v	1	2	40	1.1	88	Video Store Beer Case
v	138	4	40	1.1	24288	Video Store Ceiling
v	4	1	400	1.25	2000	Video Store Porch
v	320	1	7	1.1	2464	Video Poster Marquees
v	3	1	40	1.1	132	Video Store Soda Case
Total:					177.1	kW

Code os = overhead sales  
Key: og = overhead general  
c = refrigerated case lighting  
r = rack lighting  
p = parking lot lighting  
\* = non-fluorescent  
v = video store  
NL = non-lighting (nevertheless on circuit)

TABLE B.2b  
Summary of College Station Store Lighting Count

Summary Adj. for Schedule.	kW	kW Peak	
Fluor. Ovrhd (Main Sales)	65.5	50.2	Inside Light PLF: 0.67
Fluor. Ovrhd (Main Non-sales)	10.5	7.3	Outside Light PLF: 0.50
Fluor. Case/rack	21.6	15.8	Video Inside PLF: 0.71
Non-fluor. (Main)	14.1	9.4	
Main Total Fluor.	97.5	73.4	
Main Total	111.6	82.7	
Fluor. Ovrhd (Video Sales)	24.9	17.7	
Video Total	29.6	21.4	
Non-Lighting on Circuit	8.2	8.2	
Parking Lot/Outdoor	27.6	13.8	
Total:	177.1	126.1	

TABLE B.3a  
Summary of Amp Readings for the College Station Store  
Refrigeration Compressors System

#	Description	Amps			Defrost			LRA	Defrost cyc	min
		3-ph			Amps					
A	Meat WLKN COOLER	20	20	22				115	2	30
B	Meat Prep WLKN COOLER	19	19	20				115	2	60
C	Frl/Deli/Beer WLKN COOLER	32	31	30				240	2	50
D	Bkry & Groc WLKN FRZR	22	35	35	27	30	35	115	6	30
E	Produce Prep WLKN COOLER	22	22	22				115		
F	Nutrit/Seafd WLKN COOLER	9	9	7				82	1	60
2	28' 3-Deck Meat COOLER	21	21	21				164	4	40
3	20' LnchMeat Case COOLER	19	19	18				115	3	60
4	32' LnchMeat/Deli COOLER	26	25	25				164	3	60
5	End Cap FRZR	14	14	14	14	14	18	115	1	60
6	68' Coffin FRZR	22	21	22	39	41	39	164	1	60
7	68' Coffin FRZR	21	20	21	39	38	40	164	1	60
8	68' Coffin FRZR	21	22	21	40	39	40	164	1	60
9	68' Coffin FRZR	21	20	20	36	41	36	164	1	60
10	10' Glass Door Ice Crm FRZR	33	33	33	28	29	31	273	2	70
11	84' Produce COOLER	32	31	32				240	2	60
12	64' Island Produce COOLER	15	15	15				115	1	60
13	44' Chz & Butter COOLER	32	32	33				240	3	50
14	36' Dairy COOLER	29	26	28				164	3	60
1 15	Meat & Cheese COOLERS	24	24	25				164	2	60
16	Deli COOLER	8	7	8				82	3	60
U2	Dairy Case Roof #1	19	21	22				164	4	40
U3	Dairy Case Roof #2	22	22	22				164	4	40



TABLE B.3b  
Summary of Refrigeration Schedules for  
College Station Refrigeration Compressors

COMP#	Description	Refr.	Cut ON	Evaporator		Suct (PSI)
				Cut OFF	Head (PSI)	
A	Meat WLKN COOLER	R12	30	5	150	22
B	Meat Prep WLKN COOLER	R12	32	7	140	32
C	Flr/Deli/Beer WLKN COOLER	R12	30	5	140	17
D	Bkry & Groc WLKN FRZR	R502	?	?	220	8
E	Produce Prep WLKN COOLER	R12	35	5	170	34
F	Nutrit/Seafd WLKN COOLER	R502	33	6	165	11
2	28' 3-Deck Meat COOLER	R12	28	5	115	11
3	20' LnchMeat Case COOLER	R12	30	10	175	21
4	32' LnchMeat/Deli COOLER	R12	30	5	140	15
5	End Cap FRZR	R502	24	5	200	6
6	68' Coffin FRZR	R502	25	10	220	16
7	68' Coffin FRZR	R502	24	10	165	14
8	68' Coffin FRZR	R502	28	8	235	16
9	68' Coffin FRZR	R502	24	5	240	13
10	10' Glass Door Ice Crm FRZR	R502	22	5	195	6
11	84' Produce COOLER	R12	34	16	150	19
12	64' Island Produce COOLER	R12	34	16	145	18
13	44' Chz & Butter COOLER	R12	31	11	130	17
14	36' Dairy COOLER	R12	32	14	150	15
1 15	Meat & Cheese COOLERS	R12	25	5	130	15
16	Deli COOLER	R12	30	5	140	22
U2	Dairy Case Roof #1	R12	28	7	100	8
U3	Dairy Case Roof #2	R12	28	7	100	8

TABLE B.3c  
Summary of Rated Condenser Fan Loads  
for College Station Refrigeration Compressors

COMP#	Description	Qty.	HP (@230v)	Fan Amps (@208v)	Adj. Amps	Adj. kW in
A	Meat WLKN COOLER	2	0.3	1.7	1.54	0.28
B	Meat Prep WLKN COOLER	2	0.3	1.7	1.54	0.28
C	Frl/Deli/Beer WLKN COOLER	4	0.3	1.7	1.54	0.55
D	Bkry & Groc WLKN FRZR	4	0.3	1.7	1.54	0.55
E	Produce Prep WLKN COOLER	2	0.3	1.7	1.54	0.28
F	Nutrit/Seafd WLKN COOLER	1	0.5	2.7	2.44	0.22
2	28' 3-Deck Meat COOLER	4	0.3	1.7	1.54	0.55
3	20' LnchMeat Case COOLER	2	0.3	1.7	1.54	0.28
4	32' LnchMeat/Deli COOLER	4	0.3	1.7	1.54	0.55
5	End Cap FRZR	2	0.3	1.7	1.54	0.28
6	68' Coffin FRZR	2	0.3	1.7	1.54	0.28
7	68' Coffin FRZR	2	0.3	1.7	1.54	0.28
8	68' Coffin FRZR	2	0.3	1.7	1.54	0.28
9	68' Coffin FRZR	2	0.3	1.7	1.54	0.28
10	10' Glass Door Ice Crm FRZR	4	0.3	1.7	1.54	0.55
11	84' Produce COOLER	4	0.3	1.7	1.54	0.55
12	64' Island Produce COOLER	2	0.3	1.7	1.54	0.28
13	44' Chz & Butter COOLER	4	0.3	1.7	1.54	0.55
14	36' Dairy COOLER	4	0.3	1.7	1.54	0.55
1 15	Meat & Cheese COOLERS	4	0.3	1.7	1.54	0.55
16	Deli COOLER	2	0.3	1.7	1.54	0.28
U2	Dairy Case Roof #1	1	0.3	1.7	1.54	0.14
U3	Dairy Case Roof #2	1	0.3	1.7	1.54	0.14
Fan Load (pf = 0.75):						8.53

TABLE B.3d  
Load Summary of Compressors at College Station Store

#	Description	Refrgt	Rated HP	Meas. kW	Meas. Defr. kW
A	Meat WLKN COOLER	R12	5	5.58	5.58
B	Meat Prep WLKN COOLER	R12	5	5.22	5.22
C	Frl/Deli/Beer WLKN COOLER	R12	10	8.38	8.38
D	Bkry & Groc WLKN FRZR	R502	9	8.29	8.29
E	Produce Prep WLKN COOLER	R12	5	5.94	5.94
F	Nutri/Seafd WLKN COOLER	R502	3.1	2.25	2.25
2	28' 3-Deck Meat COOLER	R12	7.6	5.67	5.67
3	20' LnchMeat Case COOLER	R12	5	5.04	5.04
4	32' LnchMeat/Deli COOLER	R12	7.7	6.85	6.85
5	End Cap FRZR	R502	5	3.78	4.14
6	68' Coffin FRZR	R502	7.6	5.85	10.72
7	68' Coffin FRZR	R502	7.6	5.58	10.54
8	68' Coffin FRZR	R502	7.6	5.76	10.72
9	68' Coffin FRZR	R502	7.6	5.49	10.18
10	10' Glass Door Ice Crm FRZR	R502	15	8.92	7.93
11	84' Produce COOLER	R12	10	8.56	8.56
12	64' Island Produce COOLER	R12	5	4.05	4.05
13	44' Chz & Butter COOLER	R12	10	8.74	8.74
14	36' Dairy COOLER	R12	7.6	7.48	7.48
1 15	Meat & Cheese COOLERS	R12	7.6	6.57	6.57
16	Deli COOLER	R12	3.1	2.07	2.07
U2	Dairy Case Top #1	R12	7.6	5.58	5.58
U3	Dairy Case Top #2	R12	7.6	5.94	5.94
Sum:			166	137.6	156.5

## Compressors:

Running Load (supply) =	137.6 kW	pf = 0.75
Maximum Load with Defrost =	156.5 kW	eff = 0.82 (not used in calculating input power)
Rated horsepower =	166 HP	Corporate records list 148 HP (discluding 2 dairy comps)

## Fans:

Running Load = 8.53 kW

0.0914 fraction of dairy compressor HPs to remaining compressors



**TABLE B.4**  
**Bryan Store Miscellaneous Utilities Nameplate Rating Loads (continued)**

Item	Amps/ph	Volts	kW in	phase	hp	Notes
Check Stand	5	115	0.58	1		
Check Stand	5	115	0.58	1		
Check Stand	5	115	0.58	1		
Check Stand	5	115	0.58	1		
Camera Bar Register	2	115	0.23	1		
Deli Register	2	115	0.23	1		
Total:			6.79			
Other:						
Trash Baler	29	208	4.58		5.22	eff = 0.85 est.
Case and Cooler Fans	---	---	35.68	1		75 kW peak def.
Total for Utility Loads (inc. cash reg.):			161.3			
Two A.C. Units on Utility circuit:						
A.C.			3.40			conference room
A.C.			3.80			manager's office
Total			7.20			
Total inc. A.C.			168.48			
Compressor Room (on compressor circuit)						
Exhaust Fan	18	208	5.51	3	6	pf = 0.85
Exhaust Fan	18	208	5.51	3	6	
Exhaust Fan	18	208	5.51	3	6	
Exhaust Fan	18	208	5.51	3	6	
Exhaust Fan	18	208	5.51	3	6	
Total:			27.6			

TABLE B.5a  
Bryan Store Lighting Count

Use Code	Luminaires	Lamps/ Lumin.	Watts/ lamp	Ballast Factor	Total Watts	Location
c	2	1	20	1.1	44	Deli Case
c	6	2	40	1.1	528	Deli Case
c	4	3	30	1.1	396	Deli 3-DK Case
c	10	1	40	1.1	440	Cake Case
c	1	2	40	1.1	88	Pizza Case
c	2	1	100	1.1	220	Cake Freezer
c	4	1	85	1.1	374	Beer Cases
c	10	1	70	1.1	770	Ceiling Over Soda
c	5	1	40	1.1	220	Egg & Pudding Case
c	60	1	40	1.1	2640	5-DK Dairy Case
c	6	2	85	1.1	1122	Milk & Yogurt Cases
c	8	1	40	1.1	352	Milk & Yogurt Cases
c	12	2	40	1.1	1056	Sausage & Lunch Meats Decks
c	20	1	40	1.1	880	4-DK Sausage Case
c	33	1	40	1.1	1452	Poultry Deck Cases
c	4	1	40	1.1	176	Butcher's Case
c	4	1	40	1.1	176	Seafood Case
c	1	8	75	1.1	660	Juice Case
c	25	1	40	1.1	1100	Produce Cases
c	12	1	75	1.1	990	Indirect Above Prod Cases
c	24	1	40	1.1	1056	Floral Cases
c	5	1	85	1.1	467.5	FRZN Food Reach-in
c	18	1	60	1.1	1188	FRZN Food Reach-in
c	4	1	85	1.1	374	FRZN Food Reach-in
c	1	1	60	1.1	66	FRZN Food Reach-in
c*	2	1	60	1.1	132	Ice Machine Sign
og	1	4	40	1.1	176	General Ceiling
og	24	2	40	1.1	2112	General Ceiling
og	7	2	100	1.1	1540	Back Room Meat FRZR
og	3	1	100	1.1	330	Back Room Meat FRZR
og	6	2	75	1.1	990	Loading Dock
og	4	2	75	1.1	660	Meat Cutting Room
og	4	2	40	1.1	352	Meat Cutting Room
og	3	4	40	1.1	528	Front Stairwell/Breakroom
og	2	2	75	1.1	330	Front Stairwell/Breakroom
og	6	2	75	1.1	990	Produce Back Room
og	1	2	40	1.1	88	Hallway to restroom
og	2	2	75	1.1	330	restrooms
og	11	2	75	1.1	1815	Main Back Room
og	4	2	75	1.1	660	Main Dock (Prod.)
og	11	4	40	1.1	1936	Pharmacy
og	1	2	40	1.1	88	Pharmacy
og	7	4	40	1.1	1232	Mgr's Office/Halls
og	2	2	75	1.1	330	Mgr's Office/Halls
og	4	2	40	1.1	352	Entrance Vestibules
og	21	2	75	1.1	3465	Outdoor Porch
og*	8	1	120	1	960	Deli Heat lamps
og*	2	1	40	1.1	88	Deli Black Light Trap
og*	10	1	75	1.1	825	Snack Bar
og*	1	2	40	1.1	88	Dock Black Light Trap

TABLE B.5a  
Bryan Store Lighting Count (continued)

Use Code	Luminaires	Lamps/ Lumin.	Watts/ lamp	Ballast Factor	Total Watts	Location
og*	11	1	60	1.1	726	Check Stand Sign Lamps
og*	10	1	175	1.2	2100	Over Checkstands
os	200	2	75	1.1	33000	General Ceiling
os	4	2	40	1.1	352	General Ceiling
os	3	2	75	1.1	495	General Ceiling
os	32	2	40	1.1	2816	Deli Drop-ceiling
os	17	2	40	1.1	1496	Donut Drop-Ceiling
os	11	2	75	1.1	1815	Ceiling Over Soda
os	4	2	40	1.1	352	Ceiling Over Soda
os	10	2	75	1.1	1650	Ceiling Over Beer
os	1	2	40	1.1	88	Ceiling Over Beer
os	6	4	40	1.1	1056	Drop-ceiling over Milk
os	24	2	75	1.1	3960	Ceiling over Dairy & G.M.
os	5	2	40	1.1	440	Ceiling over Dairy & G.M.
os	11	4	40	1.1	1936	Drop Ceil. over Meat Cases
os	8	4	40	1.1	1408	Drop-ceil over Pork Cases
os	9	2	75	1.1	1485	Ceil over Canned Juice
os	21	2	40	1.1	1848	Drop Septum Bordering Prod.
os	4	4	40	1.1	704	Drop Over Butcher's Booth
os	4	2	40	1.1	352	Drop Over Butcher's Booth
os	6	2	75	1.1	990	Seafood Booth
os	111	4	40	1.1	19536	Ceiling over Produce
os	26	1	75	1.1	2145	Ceiling Accent Ledge Lights
os	2	1	40	1.1	88	Ceiling Accent Ledge Lights
os	16	1	20	1.1	352	Ceiling Accent Ledge Lights
os	27	4	40	1.1	4752	Below Mgr's Mezzanine
os	22	2	75	1.1	3630	Above Checkstands
os	3	2	40	1.1	264	Above Checkstands
os	21	2	40	1.1	1848	Customer Service
os	19	2	40	1.1	1672	Over Drug Displays
p	14	1	1000	1.25	17500	Parking Lot Lamps
p	8	3	8	1.1	211.2	Outer Signs (non-"curly")
p	6	1	400	1.25	3000	Outdoor Wall
r	2	1	60	1	120	Deli Case
r	5	2	25	1.1	275	Pastry Rack
r	6	4	110	1.1	2904	Over Bread Racks
r	2	2	40	1.1	176	Spice Rack
r	22	2	40	1.1	1936	Greeting Card Racks
r	16	1	40	1.1	704	Magazine Racks
r	13	1	40	1.1	572	Perfume Cases
r	12	1	40	1.1	528	Cosmetic Racks
Total:					158.5 kW	

Code Key:  
os = overhead sales  
og = overhead general  
c = refrigerated case lighting  
r = rack lighting  
p = parking lot lighting  
\* = non-fluorescent

TABLE B.5b  
Summary of Bryan Store Lighting Count

	Peak	Adjusted		
Flour. Ovrhd (Sales)	90530	71670	Inside Light PLF	0.58
Flour. Ovrhd (Non-sales)	18304	14491	Outside Light PLF	0.5
Flour. Case/rack	24183	14106		
Non-flour.	4787	2792		
Total Flour.	133017	100267		
Parking Lot/Outdoor	20711	10356		
Total:	158515	113415		



TABLE B.6a  
 Summary of Amp Readings for the Bryan Store  
 Refrigeration Compressors System

COMP#	Description	Amps 3-ph			Defrost Amps			RLA	Defrost cyc	min
1	Cheese Cases COOLER	15	17	12				21	1	70
1A	Dairy Cases	30	31	33					4	45
1B	36' Dairy Cases	27	27	28				31.1	4	60
2A	28' 5-DK Lunch Meat	32	24	29				29.4	3	70
2B	20' Lunch Meat COOLER	20	21	20				29.9	3	70
2C	Walk-in Groc FRZR	20	20	20	25	25	22	31.1	4	40
2D	Glass DR N.E. Reach-in FRZR	23	21	22				29.9	2	80
2E	4 Glass Door at Rear	30	29	29	52	33	48	29.9	1	80
2G	Ice Cream & Bakery FRZRS	30	24	30	43	40	47	31.3	2	40
2H	Glass DR N.W. Reach-in FRZR	24	22	24	32	48	44	29.9	1	60
3B	Prod., Beer, Dairy Reach-in	30	29	33					2	60
3C	Meat Cooler/Holding Box	23	23	24	18	18	19	31.1	3	38
4A	Produce Case COOLER	34	33	33					2	60
4R	Walk-in Produce & Meat Prep	35	30	34						
M-IC	44' 3-DK Red Meat Cases	34	34	35					4	58
U0	32' 13-DR DSF	17	17	17	23	25	22	23	1	60
U1	Food End Cap FRZR	13	13	14	33	30	18	22	1	60
U2	Walk-in Deli FRZR	14	14	12	15	15	15	10	4	30
U3	Deli Cases Cooler, Retarder	12	10	10				10	2	60
U4	12' Sausage Deli Case COOLER	14	14	14				22	4	40
U5	40' Frozen Meat/Spot Cases	23	23	22	52	42	42	29.9	1	62
U6	Coffin Meat and Floral Cases	12	12	13					2	70
U7	Produce Islands	24	24	24					2	50

TABLE B.6b  
Summary of Refrigeration Schedules for  
Bryan Refrigeration Compressors

#	Description		Cut ON	Evaporator		Suct (PSI)
				Cut OFF	Head (PSI)	
1	Cheese Cases COOLER	R12	29	9	100	11
1A	Dairy Cases	R12	28	10	130	20
1B	36' Dairy Cases	R12	29	10	116	16
2A	28' 5-DK Lunch Meat	R502?	28	6	110	10
2B	20' Lunch Meat COOLER	R12	27	6	115	9
2C	Walk-in Groc FRZR	R502	20	5	200	10
2D	Glass DR N.E. Reach-in FRZR	R502	28	5	160	10
2E	4 Glass Door at Rear	R502	24	5	200	15
2G	Ice Cream & Bakery FRZRS	R502?	19	1	190	5
2H	Glass DR N.W. Reach-in FRZR	R502	28	7	145	9
3B	Prod., Beer, Dairy Reach-in	R12	29	5	130	4
3C	Meat Cooler/Holding Box	R12	30	10	205	11
4A	Produce Case COOLER	R12	36	12	105	17
4R	Walk-in Produce & Meat Prep	R12	40	5	105	16
M-IC	44' 3-DK Red Meat Cases	R12	28	8	115	10
U0	32' 13-DR D5F	R22	24	13	225	13
U1	Food End Cap FRZR	R502	24	5	215	9
U2	Walk-in Deli FRZR	R502	24	5	160	14
U3	Deli Cases Cooler Retarder	R502	26	5	90	12
U4	12' Sausage Deli Case COOLER	R502	35	12	120	15
U5	40' Frozen Meat/Spot Cases	R502	26	5		10
U6	Coffin Meat and Floral Cases	R12	29	7	115	8
U7	Produce Islands	R12	35	15	125	16

TABLE B.6c  
Summary of Rated Condenser Fan Loads  
for Bryan Refrigeration Compressors

COMP#		Qty.	HP	Fans Amps (@230v)	Adj. Amps (@208v)	Adj. kW in
1	Cheese Cases COOLER	2	0.3	2.4	2.17	0.39
1A	Dairy Cases	3	0.3	1.7	1.54	0.42
1B	36' Dairy Cases	3	0.3	1.7	1.54	0.42
2A	28' 5-DK Lunch Meat	3	0.3	1.7	1.54	0.42
2B	20' Lunch Meat COOLER	2	0.3	1.7	1.54	0.28
2C	Walk-in Groc FRZR	2	0.3	1.7	1.54	0.28
2D	Glass DR N.E. Reach-in FRZR	2	0.3	1.7	1.54	0.28
2E	4 Glass Door at Rear	2	0.3	1.7	1.54	0.28
2G	Ice Cream & Bakery FRZRS	3	0.3	1.7	1.54	0.42
2H	Glass DR N.W. Reach-in FRZR	2	0.3	1.7	1.54	0.28
3B	Prod., Beer, Dairy Reach-in	3	0.3	1.7	1.54	0.42
3C	Meat Cooler/Holding Box	2	0.3	1.7	1.54	0.28
4A	Produce Case COOLER	3	0.3	1.7	1.54	0.42
4R	Walk-in Produce & Meat Prep	3	0.3	1.7	1.54	0.42
M-IC	44' 3-DK Red Meat Cases	3	0.3	1.7	1.54	0.42
U0	32' 13-DR D5F	2	0.5	2.5	2.26	0.41
U1	Food End Cap FRZR	1	0.3	2.4	2.17	0.20
U2	Walk-in Deli FRZR	1	0.3	2.4	2.17	0.20
U3	Deli Cases Cooler Retarder	1	0.3	2.4	2.17	0.20
U4	12' Sausage Deli Case COOLER	1	0.3	2.4	2.17	0.20
U5	40' Frozen Meat/Spot Cases	3	0.3	1.7	1.54	0.42
U6	Coffin Meat and Floral Cases	1	0.3	1.7	1.54	0.14
U7	Produce Islands	1	0.3	1.7	1.54	0.14
Total Fan Power						7.26

TABLE B.3d  
Load Summary of Compressors at Bryan Store

		Refr	Rated HP	Measured kW	Measured Defrost kW
1	Cheese Cases COOLER	R12	5	3.96	3.96
1A	Dairy Cases	R12	10	8.47	8.47
1B	36' Dairy Cases	R12	7.6	7.39	7.39
2A	28' 5-DK Lunch Meat	R502?	15	7.66	7.66
2B	20' Lunch Meat COOLER	R12	7.7	5.49	5.49
2C	Walk-in Groc FRZR	R502	7.6	5.40	6.48
2D	Glass DR N.E. Reach-in FRZR	R502	7.7	5.94	5.94
2E	4 Glass Door at Rear	R502	15	7.93	11.98
2G	Ice Cream & Bakery FRZRS	R502?	15	7.57	11.71
2H	Glass DR N.W. Reach-in FRZR	R502	7.7	6.30	11.17
3B	Prod., Beer, Dairy Reach-in	R12	10	8.29	8.29
3C	Meat Cooler/Holding Box	R12	7.6	6.30	4.95
4A	Produce Case COOLER	R12	15	9.01	9.01
4R	Walk-in Produce & Meat Prep	R12	10	8.92	8.92
M-IC	44' 3-DK Red Meat Cases	R12	15	9.28	9.28
U0	32' 13-DR D5F	R22	6	4.59	6.30
U1	Food End Cap FRZR	R502	5	3.60	7.30
U2	Walk-in Deli FRZR	R502	3.1	3.60	4.05
U3	Deli Cases Cooler Retarder	R502	3.1	2.88	2.88
U4	12' Sausage Deli Case COOLER	R502	5	3.78	3.78
U5	40' Frozen Meat/Spot Cases	R502	7.6	6.12	12.25
U6	Coffin Meat and Floral Cases	R12	3.1	3.33	3.33
U7	Produce Islands	R12	7.7	6.48	6.48
Total:			196	142.3	167.1

## Compressors:

Running Load = 142.3 kW      pf = 0.75  
Maximum Load with Defrost = 167.1 kW      eff = 0.82 (not used to calculate input power)  
Rated horsepower = 196 HP      Corporate records list 163 HP

## Fans:

Running Load = 7.26 kW

## **APPENDIX C**

### **INTERESTING FACTS NOTED DURING THE CASE STUDY**

This appendix contains various facts which should be of interest to the store management which were noticed during the course of this study.

#### **C.1 OPERATIONAL PROBLEMS SPOTTED THROUGH SUMMARY PLOTS**

The store management readily understood the summary inspection plots, and preferred using them to spot maintenance and operational problems. Scheduling effects could easily be seen. For instance, it was found that the parking lot lights, which are controlled by a mechanical timer, remained on during daylight hours because the timer was malfunctioning. Prior to the monitoring, this problem was spotted only when the store manager ventured out into the parking lot when the lights were on when they should not have been. The problem could be seen easily in the inspection plots. Similarly, about half of the store's interior lights were scheduled to be turned off manually from 11 p.m. until about 7 a.m. However, they frequently were left on -- about once a week. The inspection plots revealed the matter immediately and without question. The interior lights in question comprise about 90 kW which, if half are left on for 8 hours/day, cost about \$9.00/day. In 1991, this occurred about 45 days/yr, amounting to an avoidable cost associated with this problem is \$405/yr. The management has made an increased effort to turn lights off since being made aware of this problem.

#### **C.2 DELAY IN ADJUSTMENT OF PARKING LOT TIMER**

The minimum lighting load for the College Station store occurs on about July 23, rather than the expected June 21. June 21 is the summer solstice, when daylight hours are the longest and nighttime hours are the shortest. Since the management resets the timer clock on the parking lot lights on a monthly basis, the seasonal lighting schedule should lag the solstice by about 30 days, as is the case.

#### **C.3 BIMODALITY IN REFRIGERATION AND HVAC ENERGY USE**

The College Station main store HVAC load is comprised of two air-handling systems and three of the smaller video store HVAC units. As was seen in Chapter 3,

Figure 3.18 (e), the outdoor air change-point temperature for the combined HVAC load can be visually estimated at about 18.7°C (65°F). The HVAC load appears to have a linear relationship with temperature above the change-point. The data below the change-point are thought to involve mostly fan loads and dehumidification (one compressor) loads. Two modes of data are clearly present below the change-point. The lower, about 20 kW, is the fan load; the upper, at about 50 kW, is the fan load plus one compressor which is being used during the heating season for dehumidification. This is a reheating process. This bimodality shows up in the refrigeration compressor data as well.

The HVAC system is equipped with heat reclaim coils through which hot refrigerant from the refrigeration compressors can flow. These coils function as part of the refrigeration system condensers. When reheat or dehumidification is occurring, chilled air is blown across the heat-reclamation coils in the air duct. Since the air being blown across them is often cooler than the outdoor ambient air, which otherwise is used to cool the condensers, the refrigeration system operates more efficiently. The bimodality in HVAC operation has the effect of producing a bimodality in the refrigeration system energy use. These two modes may be seen in the refrigeration data below 65°F (18.7°C) (see Figure 3.18 (b)). When the refrigeration system's condenser lines are no longer exposed to outdoor ambient conditions, the effect which outdoor temperature has on the refrigeration system diminishes. The daily data in Figure 3.20b show that the two modes in the refrigeration energy use correspond to the two modes of HVAC system operation, that is, 1) when one or more stages of cooling are running, and 2) when only the air-handler fans are running. This difference is only apparent when the outdoor temperature is below the 65°F change-point. This is to be expected since waste heat from the refrigeration system is not used when there is no space heating requirement.

While the use of reheat with heat reclamation may help to explain the 65°F change-point, there is another factor involved. The condenser coils are exposed to ambient air which is drawn into the compressor room and exhausted through the roof by four large fans. As described in Chapter 3, Section 3.2.1, these fans control the room air temperature, but do not let it drop below 60°F (16°C). This means that outdoor temperatures below 60°F to 65°F should not have an effect on compressor energy use by way of the condenser coils. When heat reclaim is used, and when one stage of cooling is necessary for dehumidification purposes, energy is saved in two ways. First, the refrigeration system provides the necessary space heating. Second,

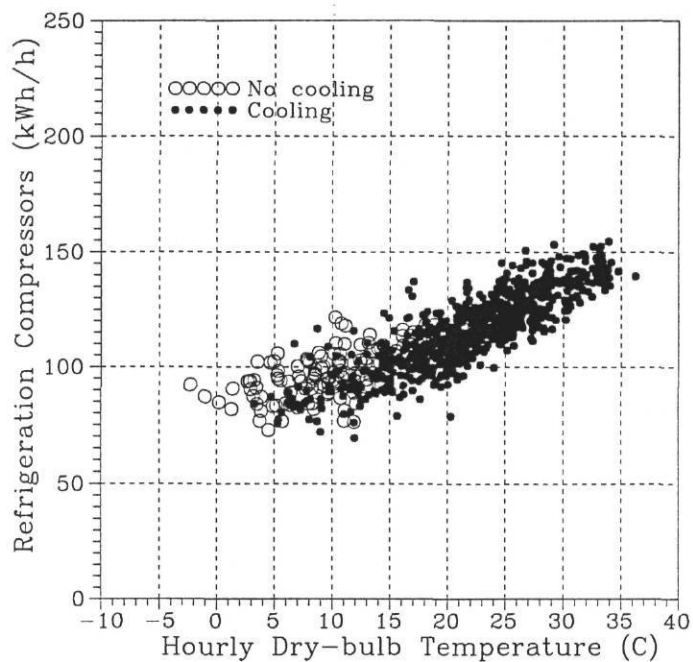
the heat reclaim coils serve as the refrigeration system condenser coils; since these coils are exposed to air which is cooler than the minimum compressor room temperature (60°F [16°C]), the refrigeration system operates more efficiently. In Figure C.1b, we see that in both modes of refrigeration system energy use, below about 60°F, the curve is fairly flat. This is to be expected since, whether the heat reclaim coils are being used or the compressor room condenser coils are used to reject heat, the temperature at which the system rejects its heat is fairly constant.

#### **C.4 HOLE IN AIR-HANDLER UNIT DUCT SPOTTED**

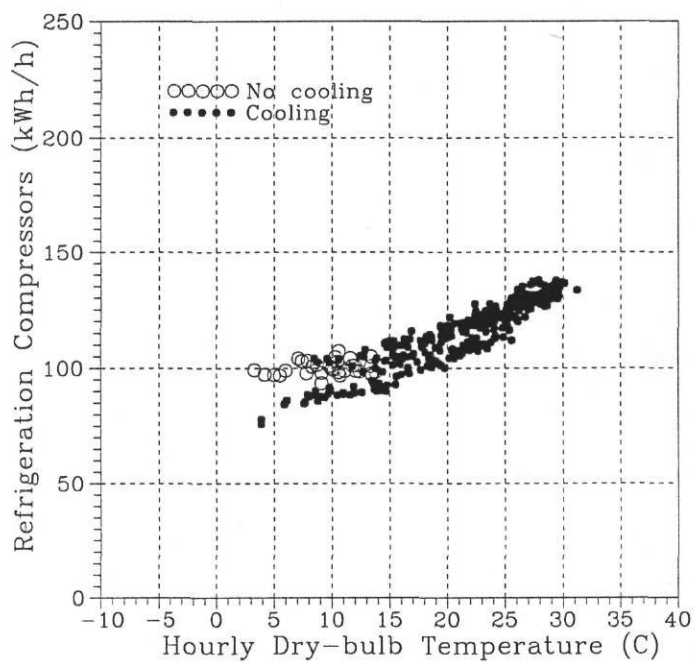
During the walk-through survey of the College Station store, a 1-foot hole was spotted in the duct-work leaving the air-handler unit #1. Air coming off the cooling coils was being dumped into the store's unconditioned back room. This problem was reported to the maintenance manager and corrected within a week. Store personnel did not know how long the leak had been present.

#### **C.5 GAS USE AT THE BRYAN STORE**

The Bryan store has a gas EUI of 14,200 Btu/ft<sup>2</sup>-yr -- about 4,200 Btu/ft<sup>2</sup>-yr less than the College Station store. And its overall annual gas use is less than that for the College Station store. However, the Bryan store's *peak* gas use is significantly higher than that of the College Station store. High peak uses can be seen in January of each year. This is clearly a result of space heating requirements during the very cold months. This occurs because the Bryan store does not use reclaim heat from the refrigeration system. Significant space heating is only used during one or two months per year for the past three years (1990 to 1992). The store's base-level consumption is about 35 million Btu/month. This is attributed to the heater pilot lights. Based on utility bill information, the average annual amount of gas used for heating is 245 million Btu/yr. If heat reclaim were used to supply this heating requirement, an estimated \$1,090/yr in natural gas bills could be saved.



(a)



(b)

**Figure C.1 a,b**

*Bimodality of refrigeration load. a) Scatter in hourly data make the two modes of energy use below 65°F (16°C) difficult to see. b) Daily data reveal the two modes of energy use. The lower mode corresponds to times when the HVAC cooling stage is running. The higher mode corresponds to times when only the fans of the HVAC system are in use.*



## APPENDIX D

### TRANSLATION OF PCA PARAMETERS INTO MLR PARAMETERS

This discussion assumes that the reader is familiar with principal component analysis in general, and is a discussion on how the SAS (1989) program implements PCA. For an in-depth explanation of the PCA technique, the reader is referred to Chen (1991), Jolliffe (1986), Rao (1964), Daultry (1976), and Draper and Smith (1981).

#### D.1 TRANSLATION RETAINING ALL PRINCIPAL COMPONENTS

PCA can be a useful tool in data analysis. But, the models which SAS predicts are in terms of the principal component variables (PCs) which it generates. They are not useful in this form, and must be converted into terms which relate to the original variables of interest. How, then, are the original variables,  $X_i$ , and the PCs related? In order to perform a PCA analysis, SAS first normalizes all variables,  $X_i$ , into variables,  $Z_i$ , which vary over a similar range. The conversion is made according to the relationship:

$$Z_i = \frac{X_i - \bar{X}_i}{S_i} \quad (\text{D.1})$$

where  $\bar{X}_i$  is the sample mean, and  $S_i$  is the sample standard deviation for the variable  $X_i$ .

SAS provides the eigenvector matrix,  $[\mathbf{q}]$  or  $[\mathbf{EIG}]$ , which defines the relationship between the principal components (PCs) and the *normalized* variables. Consider a model with three variables:

$$\begin{vmatrix} Z_1 \\ Z_2 \\ Z_3 \end{vmatrix} = \begin{vmatrix} q_{11} & q_{12} & q_{13} \\ q_{21} & q_{22} & q_{23} \\ q_{31} & q_{32} & q_{33} \end{vmatrix} \mathbf{x} \begin{vmatrix} \text{PC}_1 \\ \text{PC}_2 \\ \text{PC}_3 \end{vmatrix} \quad (\text{D.2})$$

or, rearranging,

$$\begin{bmatrix} \text{PC}_1 \\ \text{PC}_2 \\ \text{PC}_3 \end{bmatrix} = \begin{bmatrix} q_{11} & q_{12} & q_{13} \\ q_{21} & q_{22} & q_{23} \\ q_{31} & q_{32} & q_{33} \end{bmatrix}^{\text{INV}} \times \begin{bmatrix} Z_1 \\ Z_2 \\ Z_3 \end{bmatrix} \quad (\text{D.3})$$

A special quality of the eigenvector matrix is that its inverse is the same as its transpose. The PCA and MLR models must be equivalent when *all* PCs are used. Thus,

$$\text{Energy Model}_{\text{MLR}} = \text{Energy Model}_{\text{PCA}}$$

$$C_{\text{MLR}} + \{\beta_1 \ \beta_2 \ \beta_3\}_{\text{MLR}} \times \begin{bmatrix} Z_1 \\ Z_2 \\ Z_3 \end{bmatrix} = C_{\text{PCA}} + \{\beta_1 \ \beta_2 \ \beta_3\}_{\text{PCA}} \times \begin{bmatrix} \text{PC}_1 \\ \text{PC}_2 \\ \text{PC}_3 \end{bmatrix} \quad (\text{D.4a})$$

where  $C_{\text{MLR}}$  and  $C_{\text{PCA}}$  are model constants for the MLR and PCA models respectively. The  $\beta$  are the parameter estimates for the MLR and PCA models. Substituting for the [PC] matrix, we obtain,

$$C_{\text{MLR}} + \{\beta_1 \ \beta_2 \ \beta_3\}_{\text{MLR}} \times \begin{bmatrix} Z_1 \\ Z_2 \\ Z_3 \end{bmatrix} = C_{\text{PCA}} + \{\beta_1 \ \beta_2 \ \beta_3\}_{\text{PCA}} \times [\text{EIG}]^{\text{INV}} \times \begin{bmatrix} Z_1 \\ Z_2 \\ Z_3 \end{bmatrix} \quad (\text{D.4b})$$

Thus, it is apparent that the MLR parameter estimates are,

$$\{\beta_1 \ \beta_2 \ \beta_3\}_{\text{MLR}} = \{\beta_1 \ \beta_2 \ \beta_3\}_{\text{PCA}} \times [\text{EIG}]^{\text{INV}} \quad (\text{D.5})$$

and  $C_{\text{MLR}} = C_{\text{PCA}}$ .

One final transformation is necessary. That is, switching from the parameter estimates for the normalized variables,  $Z_j$ , to parameter estimates for the original variables,  $X_j$ .

The normalized MLR model is,

$$\text{Energy} = C_{\text{MLR}} + \{\beta_1 \beta_2 \beta_3\} \cdot \{Z_1 Z_2 Z_3\}^{\text{Transpose}} \quad (\text{D.6})$$

But,  $Z_i = (X_i - X_{i,\text{mean}})/S_i$ . Therefore, in terms of the original variables, the parameter estimates must be divided by the sample standard deviation for each variable. This transformation also changes the model constant. Defining  $\beta'_i$  and  $C'_{\text{MLR}}$  as the parameter estimates in terms of the original variables,

$$\beta'_i = \beta_i / S_i \quad (\text{D.7})$$

$$\begin{aligned} C'_{\text{MLR}} &= C_{\text{MLR}} - \beta'_1 \cdot X_{1,\text{mean}} - \beta'_2 \cdot X_{2,\text{mean}} - \beta'_3 \cdot X_{3,\text{mean}} \\ &= C_{\text{MLR}} - \sum \beta'_i \cdot X_{i,\text{mean}} \end{aligned} \quad (\text{D.8})$$

Q.E.D.

## D.2 TRANSLATION DROPPING ONE PRINCIPAL COMPONENT

When a PC variable is to be dropped, the PCA model is transformed back into an MLR model in a way similar to that described above. However, the values in the column corresponding to the omitted PC in the eigenvector matrix are replaced by zeros. Let's consider again the 3-PC model, but with PC3 dropped.

SAS provides the same eigenvector matrix, [q], but we make a modification.

$$\begin{vmatrix} Z_1 \\ Z_2 \\ Z_3 \end{vmatrix} = \begin{vmatrix} q_{11} & q_{12} & 0 \\ q_{21} & q_{22} & 0 \\ q_{31} & q_{32} & 0 \end{vmatrix} \times \begin{vmatrix} \text{PC}_1 \\ \text{PC}_2 \\ 0 \end{vmatrix} \quad (\text{D.9})$$

or, rearranging,

$$\begin{vmatrix} \text{PC}_1 \\ \text{PC}_2 \\ 0 \end{vmatrix} = \begin{vmatrix} q_{11} & q_{12} & 0 \\ q_{21} & q_{22} & 0 \\ q_{31} & q_{32} & 0 \end{vmatrix}^{\text{INV}} \times \begin{vmatrix} Z_1 \\ Z_2 \\ Z_3 \end{vmatrix} \quad (\text{D.10})$$

As before,

$$\text{Energy Model}_{\text{MLR}} = \text{Energy Model}_{\text{PCA}}$$

$$C_{\text{MLR}} + \{\beta_1 \ \beta_2 \ \beta_3\}_{\text{MLR}} \times \begin{vmatrix} Z_1 \\ Z_2 \\ Z_3 \end{vmatrix} = C_{\text{PCA}} + \{\beta_1 \ \beta_2\}_{\text{PCA}} \times \begin{vmatrix} \text{PC}_1 \\ \text{PC}_2 \end{vmatrix} \quad (\text{D.11a})$$

where  $C_{\text{MLR}}$  and  $C_{\text{PCA}}$  are model constants for the MLR and PCA models respectively. The  $\beta$  are the parameter estimates for the MLR and PCA models. Substituting for the [PC] matrix:

$$C_{\text{MLR}} + \{\beta_1 \ \beta_2 \ \beta_3\}_{\text{MLR}} \times \begin{vmatrix} Z_1 \\ Z_2 \\ Z_3 \end{vmatrix} = C_{\text{PCA}} + \{\beta_1 \ \beta_2\}_{\text{PCA}} \times [\text{EIG}]^{\text{INV}} \times \begin{vmatrix} Z_1 \\ Z_2 \\ Z_3 \end{vmatrix} \quad (\text{D.11b})$$

Thus, it is apparent that the MLR parameter estimates are,

$$\{\beta_1 \ \beta_2 \ \beta_3\}_{\text{MLR}} = \{\beta_1 \ \beta_2\}_{\text{PCA}} \times [\text{EIG}]^{\text{INV}} \quad (\text{D.12a})$$

and that  $C_{\text{MLR}} = C_{\text{PCA}}$ .

That is,

$$\{\beta_1 \ \beta_2 \ \beta_3\}_{\text{MLR}} = \{\beta_1 \ \beta_2\}_{\text{PCA}} \times \begin{vmatrix} q_{11} & q_{21} & q_{31} \\ q_{12} & q_{22} & q_{32} \\ 0 & 0 & 0 \end{vmatrix} \quad (\text{D.12b})$$

And, as before,

$$\beta'_i = \beta_i / S_i \quad (\text{D.13})$$

$$\begin{aligned} C'_{\text{MLR}} &= C_{\text{MLR}} - \beta'_1 \cdot X_{1,\text{mean}} - \beta'_2 \cdot X_{2,\text{mean}} - \beta'_3 \cdot X_{3,\text{mean}} \\ &= C_{\text{MLR}} - \sum \beta'_i \cdot X_{i,\text{mean}} \end{aligned} \quad (\text{D.14})$$

Q.E.D.

This matrix relationship can be easily incorporated into an algorithm in a spreadsheet. This is the method used to convert the PCA parameters for the building energy use models which SAS provides into those which can be used in models which are in terms of the original climate and sales variables.

## APPENDIX E

### STATISTICAL ANALYSIS

The three sections which follow present the data, software routine, and analyses output used in the PCA and MLR statistical analyses in Chapter 4.

#### E.1 DATA USED IN ANALYSIS

The data used for the PCA and MLR analyses are listed below. For the purposes of this display, they are divided into two groups. The first lists the date and the daily electricity component loads. The second lists the climate variables, some of which were used as predictor variables.

##### E.1.1 Building Electricity Load Data

The loads listed are: refrigeration compressors, lighting, HVAC, utility, partial video store HVAC, whole-building electricity. The columns adjacent to each load represent the number of hours recorded in each daily sum.

MO	DA	YR	COMP.	LIGHTS	HVAC	UTIL.	VID.	W.B.E.						
01	02	92	2365.3	24	3018.6	24	422.8	24	1853.3	24	35.7	24	7127.1	24
01	03	92	2325.6	24	3109.0	24	397.6	24	1851.3	24	30.9	24	7150.7	24
01	04	92	2360.2	24	3163.0	24	475.3	24	1876.3	24	34.4	24	7342.0	24
01	05	92	2342.7	24	3061.9	24	455.5	24	1895.8	24	33.3	24	7223.1	24
01	06	92	2369.8	24	3144.9	24	390.0	24	1894.4	24	26.6	24	7266.2	24
01	07	92	2420.8	24	3232.2	24	386.3	24	1912.5	24	25.0	24	7419.1	24
01	08	92	2522.0	24	3209.2	24	581.0	24	1904.5	24	47.3	24	7683.8	24
01	09	92	2519.4	24	3238.0	24	446.3	24	1872.3	24	34.3	24	7543.3	24
01	10	92	2322.0	24	3485.4	24	376.9	24	1892.1	24	21.2	24	7543.7	24
01	11	92	2356.6	24	3077.9	24	400.1	24	1867.3	24	22.4	24	7169.0	24
01	12	92	2350.6	24	3169.0	24	347.6	24	1922.3	24	14.3	24	7256.8	24
01	13	92	2425.6	24	3129.8	24	360.6	24	1884.7	24	18.7	24	7267.8	24
01	14	92	2388.7	24	3080.1	24	307.2	24	1880.5	24	6.3	24	7123.7	24
01	15	92	2374.7	24	3124.2	24	364.5	24	1868.6	24	7.3	24	7199.1	24
01	16	92	2324.7	24	3078.6	24	368.8	24	1825.9	24	3.5	24	7065.3	24
01	17	92	2283.4	24	3028.9	24	365.7	24	1833.6	24	1.8	24	6978.8	24
01	18	92	2332.7	24	3095.5	24	389.5	24	1883.1	24	1.8	24	7167.9	24
01	19	92	2381.0	24	3112.0	24	381.6	24	1914.3	24	1.8	24	7256.1	24
01	20	92	2329.0	24	3088.5	24	389.3	24	1852.8	24	3.9	24	7126.7	24
01	21	92	2347.3	24	3123.6	24	407.6	24	1868.5	24	9.8	24	7214.2	24
01	22	92	2414.9	24	3155.3	24	372.7	24	1870.2	24	1.8	24	7280.4	24
01	23	92	2530.9	24	3237.0	24	516.6	24	1894.5	24	36.7	24	7646.2	24

MO	DA	YR	COMP.	LIGHTS	HVAC	UTIL.	VID.	W.B.E.						
01	24	92	2384.3	24	3141.0	24	355.1	24	1870.2	24	13.4	24	7217.9	24
01	25	92	2425.8	24	3069.4	24	491.9	24	1877.7	24	23.1	24	7332.1	24
01	26	92	2473.6	24	3070.9	24	566.0	24	1891.0	24	38.0	24	7468.6	24
01	27	92	2530.1	24	3092.0	24	530.3	24	1881.8	24	20.6	24	7501.3	24
01	28	92	2502.6	24	3131.9	24	443.5	24	1844.4	24	13.5	24	7389.8	24
01	29	92	2467.5	24	3061.8	24	420.3	24	1820.6	24	10.9	24	7237.4	24
01	30	92	2574.6	24	3126.5	24	495.8	24	1862.2	24	12.2	24	7526.3	24
01	31	92	2618.1	24	2979.2	24	611.3	24	1860.6	24	30.6	24	7536.3	24
02	01	92	2631.5	24	3132.1	24	764.1	24	1853.3	24	49.6	24	7848.1	24
02	02	92	2616.3	24	3103.3	24	779.5	24	1841.6	24	50.5	24	7808.0	24
02	03	92	2616.9	24	3052.2	24	595.9	24	1820.3	24	36.2	24	7552.6	24
02	04	92	2587.9	24	3185.3	24	497.0	24	1828.3	24	27.7	24	7565.8	24
02	05	92	2512.9	24	3125.1	24	477.2	24	1822.2	24	11.6	24	7404.5	24
02	06	92	2500.9	24	3404.6	24	412.2	24	1840.2	24	2.2	24	7625.2	24
02	07	92	2463.0	24	3036.6	24	530.8	24	1827.9	24	19.9	24	7325.5	24
02	08	92	2497.4	24	3068.7	24	542.2	24	1821.4	24	25.6	24	7397.0	24
02	09	92	2461.5	24	3076.8	24	596.6	24	1811.2	24	29.7	24	7413.2	24
02	10	92	2421.9	24	3161.8	24	415.5	24	1821.9	24	15.5	24	7288.2	24
02	11	92	2503.4	24	3195.8	24	643.8	24	1819.1	24	43.3	24	7629.4	24
02	12	92	2682.1	24	3432.4	24	589.2	24	1849.9	24	43.5	24	8020.9	24
02	13	92	2746.4	24	3117.9	24	754.3	24	1868.7	24	56.6	24	7954.5	24
02	14	92	2758.8	24	3097.0	24	934.6	24	1881.6	24	74.3	24	8139.2	24
02	15	92	2859.8	24	3187.1	24	1011.4	24	1905.4	24	95.4	24	8430.9	24
02	16	92	2829.2	24	3113.5	24	816.6	24	1910.4	24	94.4	24	8136.9	24
02	17	92	2698.0	24	3068.5	24	631.8	24	1853.2	24	65.9	24	7718.7	24
02	18	92	2620.0	24	3057.7	24	777.6	24	1854.2	24	61.6	24	7776.7	24
02	19	92	2405.2	24	3024.1	24	867.4	24	1797.7	24	51.5	24	7561.6	24
02	20	92	2443.9	24	3082.4	24	756.6	24	1817.0	24	47.6	24	7567.1	24
02	21	92	2430.9	24	3110.1	24	794.3	24	1820.2	24	53.1	24	7622.8	24
02	22	92	2529.1	24	3095.5	24	830.3	24	1841.9	24	63.1	24	7764.0	24
02	23	92	2654.0	24	3039.5	24	849.8	24	1840.8	24	76.7	24	7851.3	24
02	24	92	2681.7	24	3045.4	24	820.2	24	1856.4	24	83.3	24	7870.9	24
02	25	92	2678.3	24	3192.2	24	712.2	24	1889.6	24	54.4	24	7939.6	24
02	26	92	2499.0	24	3187.6	24	682.1	24	1882.3	24	8.2	24	7718.3	24
02	27	92	2433.1	24	3121.2	24	483.2	24	1833.9	24	21.9	24	7338.5	24
02	28	92	2472.7	24	3038.0	24	683.2	24	1848.4	24	44.4	24	7509.5	24
02	29	92	2548.1	24	3055.3	24	791.3	24	1830.2	24	66.7	24	7692.0	24
03	01	92	2599.1	24	3009.8	24	947.4	24	1918.8	24	90.6	24	7942.3	24
03	02	92	2582.8	24	2948.9	24	924.2	24	1812.0	24	65.3	24	7735.1	24
03	03	92	2688.6	24	3006.9	24	864.9	24	1774.4	24	55.5	24	7802.0	24
03	04	92	2789.9	24	2975.1	24	771.9	24	1844.0	24	60.6	24	7848.1	24
03	05	92	2777.2	24	3103.8	24	500.8	24	1842.5	24	40.9	24	7691.5	24
03	06	92	2866.4	24	3030.3	24	814.0	24	1881.8	24	76.1	24	8059.6	24
03	07	92	2920.4	24	3022.4	24	912.5	24	1894.1	24	91.2	24	8216.6	24
03	08	92	2828.9	24	3079.8	24	859.5	24	1886.0	24	90.5	24	8121.5	24
03	09	92	2809.2	24	3102.3	24	867.4	24	1835.1	24	81.0	24	8081.2	24
03	10	92	2923.8	24	3368.3	24	895.7	24	1813.3	24	65.0	24	8468.4	24
03	11	92	2477.2	24	3112.9	24	299.4	24	1781.5	24	8.8	24	7138.2	24
03	12	92	2473.0	24	3155.0	24	328.6	24	1760.9	24	10.4	24	7184.6	24
03	13	92	2517.6	24	3066.2	24	543.6	24	1799.3	24	37.4	24	7393.9	24

MO	DA	YR	COMP.	LIGHTS	HVAC	UTIL.	VID.	W.B.E.						
03	14	92	2654.1	24	3139.5	24	622.6	24	1860.9	24	53.1	24	7744.3	24
03	15	92	2726.0	24	3057.7	24	754.8	24	1849.0	24	72.6	24	7854.6	24
03	16	92	2770.9	24	3059.3	24	824.5	24	1824.9	24	80.3	24	7946.9	24
03	17	92	2837.2	24	2991.8	24	842.1	24	1833.5	24	78.2	24	7971.9	24
03	18	92	2804.3	24	3059.8	24	849.7	24	1887.2	24	78.5	24	8068.1	24
03	19	92	2909.7	24	3088.9	24	968.0	24	1869.1	24	91.8	24	8302.9	24
03	20	92	2516.9	24	3358.5	24	1004.4	24	1835.1	24	56.9	24	8182.2	24
03	21	92	2477.8	24	3003.4	24	804.0	24	1823.9	24	51.5	24	7576.3	24
03	22	92	2634.0	24	2982.0	24	719.4	24	1820.1	24	50.7	24	7622.6	24
03	23	92	2666.0	24	3044.4	24	720.3	24	1835.3	24	49.0	24	7733.2	24
03	24	92	2483.9	24	3097.1	24	574.6	24	1847.6	24	33.7	24	7470.3	24
03	25	92	2606.5	24	3382.7	24	713.8	24	1845.4	24	50.9	24	8015.6	24
03	26	92	2708.3	24	3085.4	24	910.4	24	1842.8	24	78.8	24	8014.2	24
03	27	92	2665.3	24	2957.4	24	1031.5	24	1836.1	24	78.9	24	7957.5	24
03	28	92	2734.7	24	3145.4	24	1070.4	24	1840.2	24	84.8	24	8257.9	24
03	29	92	2696.8	24	3229.4	24	786.9	24	1845.5	24	83.1	24	8025.8	24
03	30	92	2767.2	24	2976.8	24	962.4	24	1866.0	24	75.0	24	8039.6	24
03	31	92	2582.1	24	3015.4	24	862.6	24	1847.9	24	51.1	24	7775.2	24
04	01	92	2533.1	24	3013.9	24	861.6	24	1819.3	24	66.7	24	7695.2	24
04	02	92	2516.0	24	3083.9	24	878.5	24	1820.6	24	50.2	24	7766.2	24
04	03	92	2243.3	24	3056.7	24	512.9	24	1796.7	24	14.6	24	7076.7	24
04	04	92	2361.0	24	3052.4	24	787.3	24	1816.3	24	47.6	24	7484.2	24
04	05	92	2488.2	24	2944.4	24	876.1	24	1848.9	24	69.2	24	7624.8	24
04	06	92	2397.3	24	2925.0	24	834.1	24	1817.7	24	32.3	24	7441.2	24
04	07	92	2566.8	24	2891.8	24	957.2	24	1838.8	24	55.9	24	7721.7	24
04	08	92	2593.6	23	2894.7	23	997.6	23	1780.4	23	82.6	23	7733.5	23
04	09	92	2849.6	24	3072.1	24	964.8	24	1811.1	24	193.0	24	8164.7	24
04	10	92	2796.4	24	2942.3	24	849.2	24	1794.3	24	215.1	24	7849.4	24
04	11	92	2842.0	24	3008.4	24	1042.4	24	1891.7	24	225.1	24	8251.7	24
04	12	92	2939.4	24	2989.3	24	1063.9	24	1902.9	24	241.0	24	8362.7	24
04	13	92	2983.3	24	2954.9	24	1205.5	24	1927.2	24	196.5	24	8538.1	24
04	14	92	3021.8	24	2943.7	24	992.3	24	1909.5	24	139.1	24	8334.5	24
04	15	92	3059.2	24	3026.1	24	1018.9	24	1966.5	24	153.0	24	8538.0	24
04	16	92	3058.9	24	3093.8	24	1056.5	24	1960.6	24	141.7	24	8636.9	24
04	17	92	2989.3	24	2976.2	24	1352.5	24	1886.9	24	142.9	24	8672.1	24
04	18	92	2816.1	24	3083.3	24	1391.5	24	1906.8	24	119.5	24	8665.0	24
04	19	92	2836.6	24	2987.5	24	1150.7	24	1923.0	24	110.6	24	8365.0	24
04	20	92	2810.6	24	2921.5	24	1299.0	24	1829.4	24	113.0	24	8327.7	24
04	21	92	2701.5	24	2949.4	24	1004.8	24	1872.9	24	90.5	24	7995.8	24
04	22	92	2710.5	24	2948.5	24	1081.4	24	1866.3	24	118.0	24	8073.9	24
04	23	92	2864.3	24	3026.0	24	1403.3	24	1851.1	24	163.2	24	8612.0	24
04	24	92	2950.0	24	3010.3	24	1399.6	24	1869.1	24	205.8	24	8696.3	24
04	25	92	2998.7	24	2907.1	24	1847.8	24	1872.2	24	222.5	24	9093.1	24
04	26	92	2735.5	24	3222.5	24	1468.7	24	1906.0	24	176.7	24	8799.9	24
04	27	92	2707.3	24	2890.5	24	1214.0	24	1861.2	24	178.1	24	8140.2	24
04	28	92	2755.8	24	3010.7	24	1330.3	24	1854.0	24	182.8	24	8418.0	24
04	29	92	2775.6	24	2953.3	24	1443.9	24	1846.5	24	194.6	24	8486.5	24
04	30	92	2891.5	24	2938.8	24	1515.9	24	1871.4	24	194.8	24	8684.8	24
05	01	92	2724.7	24	2978.3	24	1180.2	24	1900.1	24	193.0	24	8250.5	24
05	02	92	2874.3	24	2959.6	24	1326.4	24	1886.8	24	238.3	24	8514.3	24
05	03	92	2988.1	24	2933.0	24	1429.8	24	1878.6	24	252.4	24	8696.8	24



MO	DA	YR	COMP.	LIGHTS	HVAC	UTIL.	VID.	W.B.E.						
05	04	92	2986.8	24	2936.6	24	1549.0	24	1891.8	24	257.8	24	8831.4	24
05	05	92	2914.7	24	2898.7	24	1656.4	24	1910.8	24	225.8	24	8847.8	24
05	06	92	2870.8	24	2913.7	24	1627.8	24	1874.7	24	244.5	24	8754.2	24
05	07	92	2724.5	24	3011.4	24	1527.8	24	1859.5	24	197.5	24	8590.5	24
05	08	92	2542.3	24	2978.0	24	1304.5	24	1861.3	24	177.1	24	8153.3	24
05	09	92	2616.2	24	2988.5	24	1371.1	24	1881.4	24	201.7	24	8324.4	24
05	10	92	2707.8	24	2955.9	24	1400.1	24	1842.8	24	212.8	24	8373.7	24
05	11	92	2820.6	24	2965.7	24	1553.9	24	1822.3	24	202.1	24	8629.7	24
05	12	92	2968.3	24	3018.2	24	1478.6	24	1860.3	24	241.9	24	8792.7	24
05	13	92	2902.2	24	2921.5	24	1959.5	24	1839.2	24	282.5	24	9089.7	24
05	14	92	2886.0	24	2959.6	24	1948.0	24	1841.6	24	250.3	24	9102.5	24
05	15	92	3018.7	24	2821.7	24	2038.3	24	1847.7	24	274.9	24	9193.7	24
05	16	92	2875.8	24	2871.0	24	1639.3	24	1920.2	24	214.6	24	8773.4	24
05	17	92	2876.1	24	2900.2	24	1494.9	24	1904.3	24	217.2	24	8642.7	24
05	18	92	2793.1	24	2840.4	24	1541.7	24	1882.4	24	207.7	24	8524.8	24
05	19	92	2842.3	24	3017.2	24	1459.2	24	1862.2	24	200.2	24	8648.2	24
05	20	92	2906.3	24	2912.2	24	1637.7	24	1837.5	24	231.1	24	8760.8	24
05	21	92	2895.2	24	2939.9	24	1560.2	24	1839.5	24	227.4	24	8701.9	24
05	22	92	2838.5	24	2916.2	24	1558.5	24	1826.5	24	213.0	24	8606.9	24
05	23	92	2907.8	24	2860.8	24	1651.2	24	1855.3	24	226.8	24	8742.3	24
05	24	92	2950.1	24	2842.3	24	1676.7	24	1835.6	24	254.2	24	8772.0	24
05	25	92	2982.2	24	2847.9	24	1942.1	24	1816.9	24	261.2	24	9056.2	24
05	26	92	2988.2	24	2887.7	24	1866.1	24	1838.9	24	268.7	24	9048.1	24
05	27	92	2895.2	24	2925.1	24	1793.1	24	1825.5	24	253.3	24	8906.2	24
05	28	92	2885.4	24	3218.5	24	1879.0	24	1840.8	24	240.9	24	9290.9	24
05	29	92	2685.7	23	2758.4	23	1111.4	23	1718.5	23	216.6	23	7741.1	23
05	30	92	2513.8	24	2941.3	24	349.5	24	1784.0	24	164.2	24	7055.8	24
05	31	92	2613.6	24	2895.5	24	434.7	24	1803.6	24	191.8	24	7214.7	24
06	01	92	2690.6	24	2865.3	24	441.4	24	1820.5	24	198.7	24	7284.9	24
06	02	92	2839.0	24	2927.9	24	490.7	24	1871.4	24	233.0	24	7596.2	24
06	03	92	2814.0	24	2963.5	24	1376.6	24	1803.5	24	225.3	24	8424.8	24
06	04	92	3030.9	24	2962.3	24	1786.5	24	1848.6	24	251.3	24	9095.5	24
06	05	92	3031.1	24	2803.7	24	2023.5	24	1819.0	24	267.5	24	9144.4	24
06	06	92	3085.8	24	2888.5	24	2209.6	24	1810.7	24	290.1	24	9461.8	24
06	07	92	3034.6	24	2893.0	24	2002.8	24	1838.3	24	240.6	24	9235.9	24
06	08	92	2931.8	24	2816.6	24	1842.0	24	1733.9	24	243.1	24	8791.6	24
06	09	92	3066.5	24	3001.7	24	2280.1	24	1800.5	24	280.5	24	9616.0	24
06	10	92	3052.5	24	2957.5	24	2116.8	24	1859.2	24	284.4	24	9453.3	24
06	11	92	3109.2	24	2938.8	24	2274.5	24	1849.0	24	297.6	24	9638.7	24
06	12	92	3137.2	24	2881.3	24	2290.5	24	1826.3	24	306.8	24	9602.6	24
06	13	92	3158.0	24	2884.4	24	2353.6	24	1852.4	24	318.6	24	9715.6	24
06	14	92	3130.1	24	2909.5	24	2230.3	24	1852.2	24	316.7	24	9589.4	24
06	15	92	3131.8	24	2907.6	24	2283.1	24	1809.0	24	330.2	24	9598.8	24
06	16	92	3175.5	24	2917.8	24	2430.9	24	1840.4	24	327.0	24	9831.8	24
06	17	92	3201.3	24	2918.2	24	2438.3	24	1842.9	24	333.2	24	9867.9	24
06	18	92	3200.7	24	2917.4	24	2410.0	24	1835.0	24	348.9	24	9830.2	24
06	19	92	3161.4	24	2896.8	24	2400.0	24	1795.1	24	328.6	24	9720.5	24
06	20	92	3220.8	24	2935.6	24	2361.5	24	1845.9	24	336.5	24	9831.0	24
06	21	92	3256.1	24	2882.5	24	2308.6	24	1831.5	24	337.7	24	9745.9	24
06	22	92	3233.8	24	2868.2	24	2296.8	24	1819.0	24	332.5	24	9685.0	24
06	23	92	3121.9	24	3004.6	24	2067.8	24	1821.7	24	292.4	24	9483.3	24

MO	DA	YR	COMP.	LIGHTS	HVAC	UTIL.	VID.	W.B.E.						
06	24	92	3156.4	24	2915.1	24	2204.9	24	1833.4	24	320.7	24	9577.0	24
06	25	92	3220.9	24	2916.3	24	2252.9	24	1774.8	24	340.5	24	9632.1	24
06	26	92	3230.3	24	2906.1	24	2271.9	24	1802.4	24	282.3	24	9677.9	24
06	27	92	3243.4	24	3271.1	24	1996.4	24	1813.4	24	419.7	24	9791.5	24
06	28	92	3172.6	24	3071.0	24	1694.0	24	1825.9	24	415.8	24	9230.8	24
06	29	92	3171.7	24	2867.8	24	1760.8	24	1794.0	24	420.0	24	9061.6	24
06	30	92	3206.1	24	2907.7	24	2133.4	24	1785.2	24	417.7	24	9499.7	24
07	01	92	3106.7	24	2915.7	24	2211.6	24	1804.2	24	399.0	24	9505.4	24
07	02	92	3113.9	24	2890.0	24	2328.4	24	1854.6	24	397.5	24	9654.1	24
07	03	92	3273.8	24	2896.4	24	2574.7	24	1846.4	24	418.3	24	10058.5	24
07	04	92	3158.7	24	2877.4	24	2397.4	24	1868.2	24	396.4	24	9768.9	24
07	05	92	3126.4	24	2945.5	24	2175.3	24	1811.3	24	316.3	24	9525.7	24
07	06	92	3108.3	24	2897.3	24	2383.1	24	1798.2	24	339.0	24	9654.1	24
07	07	92	3044.8	24	2875.6	24	2392.7	24	1802.1	24	336.3	24	9582.5	24
07	08	92	3142.0	24	2927.6	24	2402.9	24	1821.3	24	342.9	24	9761.0	24
07	09	92	3167.2	24	2843.7	24	2308.4	24	1820.1	24	351.7	24	9606.6	24
07	10	92	3159.8	24	2977.0	24	2533.7	24	1796.7	24	349.3	24	9934.4	24
07	11	92	3168.7	24	2813.5	24	2387.9	24	1798.4	24	344.4	24	9635.6	24
07	12	92	3144.3	24	2811.4	24	2390.9	24	1811.8	24	344.8	24	9625.7	24
07	13	92	3145.8	24	2860.4	24	2459.5	24	1804.7	24	341.4	24	9737.6	24
07	14	92	3178.0	24	3052.6	24	2521.1	24	1832.0	24	339.1	24	10050.9	24
07	15	92	3165.0	24	2806.7	24	2506.3	24	1842.7	24	348.6	24	9787.9	24
07	16	92	3183.3	24	2822.9	24	2599.7	24	1844.1	24	351.8	24	9917.3	24
07	17	92	3200.0	24	2817.5	24	2578.6	24	1812.9	24	356.3	24	9876.2	24
07	18	92	3170.5	24	2863.1	24	2516.5	24	1816.3	24	352.3	24	9833.5	24
07	19	92	3098.1	24	3211.2	24	2350.6	24	1838.9	24	334.2	24	9965.9	24
07	20	92	2914.5	24	2856.6	24	1886.1	24	1748.7	24	319.8	24	8873.1	24
07	21	92	2861.5	24	2958.8	24	1816.8	24	1778.1	24	322.5	24	8882.4	24
07	22	92	2934.7	24	2795.2	24	1938.9	24	1818.1	24	318.2	24	8954.1	24
07	23	92	3002.7	24	2819.2	24	2177.7	24	1808.9	24	328.8	24	9275.6	24
07	24	92	3061.8	24	2825.6	24	2278.7	24	1796.1	24	334.7	24	9429.4	24
07	25	92	3134.5	24	2840.5	24	2369.7	24	1812.2	24	344.7	24	9624.1	24
07	26	92	3175.4	24	2850.3	24	2533.8	24	1808.5	24	349.8	24	9835.1	24
07	27	92	3137.0	24	2849.7	24	2505.5	24	1808.6	24	352.9	24	9768.0	24
07	28	92	3164.7	24	2783.6	24	2556.9	24	1831.9	24	352.6	24	9804.3	24
07	29	92	3138.1	24	2929.6	24	2568.2	24	1851.6	24	356.3	24	9954.7	24
07	30	92	3108.2	24	2829.7	24	2477.3	24	1853.3	24	353.9	24	9735.8	24
07	31	92	3141.0	24	2752.3	24	2576.4	24	1842.3	24	355.6	24	9779.1	24
08	01	92	3172.9	24	2842.1	24	2575.7	24	1863.5	24	354.7	24	9921.4	24
08	02	92	3143.2	24	2835.1	24	2551.2	24	1827.7	24	351.9	24	9824.4	24
08	03	92	3013.9	24	2889.2	24	2419.3	24	1845.6	24	351.2	24	9635.2	24
08	04	92	2990.9	24	2838.8	24	2257.3	24	1843.2	24	331.5	24	9397.4	24
08	05	92	3168.4	24	2799.1	24	2431.1	24	1863.3	24	343.5	24	9729.1	24
08	06	92	3202.9	24	2736.8	24	2456.0	24	1848.9	24	357.7	24	9711.9	24
08	07	92	3240.7	24	2862.6	24	2482.9	24	1815.4	24	351.6	24	9868.7	24
08	08	92	3273.9	24	2925.7	24	2508.5	24	1864.2	24	357.6	24	10039.5	24
08	09	92	3301.8	24	2844.7	24	2511.3	24	1858.3	24	357.0	24	9983.3	24
08	10	92	3262.8	24	2892.6	24	2559.0	24	1821.4	24	355.4	24	10003.0	24
08	11	92	3284.3	24	2888.1	24	2612.8	24	1823.5	24	318.6	24	10075.9	24
08	12	92	3087.0	24	2864.6	24	2650.2	24	1811.7	24	258.2	24	9880.7	24
08	13	92	3101.4	24	2843.4	24	2423.5	24	1829.3	24	255.7	24	9664.8	24

MO	DA	YR	COMP.	LIGHTS	HVAC	UTIL.	VID.	W.B.E.						
08	14	92	3132.2	24	2886.3	24	2487.2	24	1839.2	24	257.2	24	9812.1	24
08	15	92	3157.7	24	2957.9	24	2511.5	24	1858.5	24	259.0	24	9952.8	24
08	16	92	3042.1	24	2922.8	24	2400.2	24	1876.4	24	255.0	24	9708.7	24
08	17	92	2892.9	24	2900.2	24	2061.8	24	1828.4	24	249.3	24	9150.5	24
08	18	92	2916.8	24	2876.9	24	2067.7	24	1838.7	24	247.9	24	9167.3	24
08	19	92	2963.2	24	2838.0	24	2159.6	24	1855.8	24	254.1	24	9283.9	24
08	20	92	2922.4	24	2890.3	24	2122.6	24	1853.8	24	250.8	24	9256.4	24
08	21	92	3010.2	24	3121.9	24	2196.9	24	1803.7	24	250.1	24	9599.8	24
08	22	92	3076.3	24	2849.1	24	2230.3	24	1850.2	24	252.5	24	9473.1	24
08	23	92	3119.1	24	2840.0	24	2329.9	24	1882.4	24	257.7	24	9638.5	24
08	24	92	3102.1	24	2894.4	24	2326.9	24	1849.7	24	259.5	24	9640.3	24
08	25	92	3150.6	24	2803.6	24	2350.6	24	1839.7	24	261.6	24	9611.6	24
08	26	92	3182.4	24	2852.2	24	2521.4	24	1882.6	24	264.7	24	9905.9	24
08	27	92	3262.5	24	2872.9	24	2648.6	24	1847.5	24	268.4	24	10098.6	24
08	28	92	3087.5	24	2767.4	24	2442.1	24	1830.1	24	260.2	24	9594.3	24
08	29	92	3010.8	24	2912.7	24	2265.9	24	1840.8	24	257.2	24	9497.4	24
08	30	92	3074.4	24	3028.8	24	2321.6	24	1880.8	24	258.4	24	9772.8	24
08	31	92	3030.2	24	2864.7	24	2311.1	24	1860.8	24	260.6	24	9534.0	24
09	01	92	3051.7	24	2934.1	24	2255.9	24	1870.8	24	259.5	24	9579.7	24
09	02	92	3103.2	24	2911.6	24	2387.3	24	1867.4	24	263.1	24	9736.7	24
09	03	92	3200.1	24	2933.6	24	2462.2	24	1872.0	24	268.4	24	9935.1	24
09	04	92	3131.4	24	2879.7	24	2228.5	24	1870.6	24	335.6	24	9577.5	24
09	05	92	3118.6	24	2978.7	24	2081.9	24	1888.6	24	415.8	24	9535.1	24
09	06	92	3259.0	24	3216.8	24	2274.1	24	1879.3	24	428.4	24	10096.3	24
09	07	92	3305.5	24	2984.5	24	2332.4	24	1893.0	24	444.8	24	9982.6	24
09	08	92	3263.7	24	2917.4	24	2440.3	24	1880.2	24	364.1	24	9968.7	24
09	09	92	3251.2	24	2976.4	24	2450.5	24	1879.5	24	349.9	24	10024.8	24
09	10	92	3144.8	24	2946.6	24	2160.3	24	1876.5	24	347.9	24	9595.4	24
09	11	92	3275.2	24	2952.4	24	2145.0	24	1870.3	24	346.8	24	9710.1	24
09	12	92	3241.4	24	2962.2	24	2030.9	24	1891.5	24	324.3	24	9593.2	24
09	13	92	3291.7	24	3022.1	24	2137.0	24	1875.3	24	344.9	24	9793.3	24
09	14	92	3206.8	24	2980.5	24	2122.1	24	1878.0	24	338.4	24	9654.7	24
09	15	92	3168.7	24	2938.7	24	2030.5	24	1880.2	24	319.7	24	9485.3	24
09	16	92	3167.9	24	3033.0	24	1874.1	24	1857.8	24	324.6	24	9400.0	24
09	17	92	2925.1	24	3046.8	24	1942.1	24	1844.8	24	312.1	24	9226.0	24
09	18	92	3077.7	24	2950.5	24	2269.5	24	1812.8	24	282.6	24	9577.7	24
09	19	92	3090.7	24	3017.3	24	2403.4	24	1834.4	24	278.2	24	9813.1	24
09	20	92	3124.1	24	2914.0	24	2481.8	24	1890.8	24	285.2	24	9877.9	24
09	21	92	3037.9	24	2979.9	24	2499.8	24	1893.6	24	298.9	24	9878.5	24
09	22	92	3064.8	24	2920.4	24	2436.6	24	1898.6	24	297.8	24	9787.6	24
09	23	92	2912.5	24	2892.8	24	2126.1	24	1839.0	24	260.1	24	9237.6	24
09	24	92	2773.3	24	2983.6	24	1947.3	24	1846.5	24	223.3	24	9017.9	24
09	25	92	2634.2	24	2933.3	24	1664.8	24	1818.6	24	181.4	24	8518.1	24
09	26	92	2797.2	24	2929.4	24	1811.1	24	1838.0	24	204.5	24	8842.9	24
09	27	92	2878.1	24	2892.6	24	2007.5	24	1865.6	24	224.1	24	9111.0	24
09	28	92	2833.7	24	2882.3	24	2143.2	24	1869.2	24	227.6	24	9195.6	24
09	29	92	2709.8	24	2931.0	24	1813.9	24	1854.0	24	213.5	24	8775.9	24
09	30	92	2647.3	24	2969.4	24	1677.8	24	1836.2	24	199.7	24	8597.9	24
10	01	92	2431.9	24	3015.6	24	1494.3	24	1758.9	24	184.9	24	8167.9	24
10	02	92	2503.1	24	2988.6	24	1570.1	24	1787.1	24	60.6	24	8316.1	24
10	03	92	2558.2	24	3010.5	24	1684.9	24	1807.3	24	47.4	24	8528.1	24

MO	DA	YR	COMP.	LIGHTS	HVAC	UTIL.	VID.	W.B.E.						
10	04	92	2608.0	24	3112.8	24	1682.7	24	1831.1	24	103.1	24	8701.8	24
10	05	92	2604.2	24	3004.2	24	1737.9	24	1856.2	24	112.9	24	8669.6	24
10	06	92	2703.2	24	3017.1	24	1791.7	24	1851.9	24	110.9	24	8831.1	24
10	07	92	2645.1	24	2931.3	24	1778.5	24	1842.7	24	111.2	24	8664.8	24
10	08	92	2676.1	24	3026.2	24	1751.7	24	1862.1	24	119.8	24	8783.2	24
10	09	92	2346.3	24	2957.9	24	1305.5	24	1801.7	24	76.8	24	7878.7	24
10	10	92	2503.1	24	3010.8	24	1467.3	24	1835.1	24	108.2	24	8283.4	24
10	11	92	2814.9	24	2972.6	24	1899.0	24	1870.5	24	142.4	24	9024.2	24
10	12	92	2586.2	24	2974.7	24	1688.6	24	1849.2	24	122.8	24	8565.8	24
10	13	92	2579.3	24	2956.1	24	1627.5	24	1822.6	24	112.2	24	8452.7	24
10	14	92	2627.7	24	2942.9	24	1662.3	24	1824.1	24	126.2	24	8524.4	24
10	15	92	2734.1	24	3062.8	24	1828.1	24	1825.4	24	132.2	24	8917.6	24
10	16	92	2789.2	24	2999.9	24	1994.8	24	1817.9	24	135.6	24	9069.0	24
10	17	92	2712.2	24	3006.5	24	1803.0	24	1831.0	24	140.9	24	8820.0	24
10	18	92	2534.9	24	3033.6	24	1385.9	24	1806.1	24	140.7	24	8227.7	24
10	19	92	2475.1	24	2981.0	24	1468.3	24	1818.5	24	137.0	24	8210.1	24
10	20	92	2313.9	23	2830.1	23	1341.8	23	1737.5	23	95.1	23	7690.5	23
10	21	92	2530.2	24	2990.8	24	1592.9	24	1827.2	24	93.9	24	8408.3	24
10	22	92	2596.5	24	2977.8	24	1725.5	24	1807.9	24	104.8	24	8574.9	24
10	23	92	2629.3	24	2899.5	24	1721.7	24	1853.9	24	105.6	24	8571.6	24
10	24	92	2650.1	24	2985.7	24	1785.3	24	1851.3	24	113.7	24	8739.7	24
10	25	92	2664.8	24	2973.1	24	1754.1	24	1863.1	24	123.9	24	8722.3	24
10	26	92	2687.1	24	2858.1	24	1796.9	24	1897.4	24	133.9	24	8706.7	24
10	27	92	2718.6	24	2946.7	24	1877.7	24	1871.5	24	135.6	24	8881.7	24
10	28	92	2648.7	24	3104.4	24	1778.5	24	1844.2	24	109.7	24	8843.0	24
10	29	92	2607.3	24	3016.4	24	1712.0	24	1826.0	24	111.8	24	8628.9	24
10	30	92	2709.6	24	2946.0	24	1871.5	24	1805.7	24	122.9	24	8800.0	24
10	31	92	2665.7	24	2965.3	24	1776.9	24	1810.3	24	103.3	24	8685.4	24
11	01	92	2880.7	24	2930.5	24	2025.1	24	1828.5	24	118.1	24	9131.9	24
11	02	92	2584.5	24	2957.0	24	1702.6	24	1809.3	24	74.5	24	8520.5	24
11	03	92	2449.9	24	3216.6	24	1457.4	24	1808.5	24	59.7	24	8399.6	24
11	04	92	2481.4	24	3006.4	24	1593.0	24	1770.9	24	59.3	24	8318.9	24
11	05	92	2161.2	24	3105.7	24	918.1	24	1750.2	24	29.2	24	7402.4	24
11	06	92	2105.1	24	3025.8	24	906.9	24	1765.8	24	30.2	24	7270.7	24
11	07	92	2131.1	24	3009.5	24	878.4	24	1787.9	24	29.8	24	7274.1	24
11	08	92	2205.6	24	2992.1	24	868.6	24	1790.2	24	29.5	24	7323.7	24
11	09	92	2313.2	24	2989.8	24	1113.1	24	1825.9	24	29.2	24	7709.2	24
11	10	92	2579.0	24	3109.0	24	1600.5	24	1827.9	24	108.4	24	8583.7	24
11	11	92	2588.4	24	2980.3	24	1608.4	24	1762.6	24	134.1	24	8406.9	24
11	12	92	2670.3	24	3056.0	24	1629.7	24	1799.1	24	85.1	24	8622.3	24
11	13	92	2167.0	24	3083.3	24	1128.9	24	1753.2	24	57.9	24	7599.6	24
11	14	92	2420.3	24	3105.5	24	1107.4	24	1871.3	24	48.0	24	7971.7	24
11	15	92	2239.9	24	2988.7	24	1060.6	24	1845.8	24	47.9	24	7602.3	24
11	16	92	2237.6	24	3023.7	24	1003.0	24	1823.4	24	51.8	24	7554.9	24
11	17	92	2333.1	24	3096.3	24	1202.1	24	1813.6	24	58.6	24	7912.2	24
11	18	92	2464.4	24	2974.9	24	1304.6	24	1802.6	24	73.1	24	8013.7	24
11	19	92	2508.0	24	3011.1	24	1514.4	24	1862.1	24	71.6	24	8362.8	24
11	20	92	2468.2	24	3046.3	24	1470.8	24	1818.8	24	73.8	24	8271.2	24
11	25	92	2270.0	24	2989.7	24	1166.5	24	1848.0	24	44.3	24	7741.5	24
11	26	92	2050.7	24	2909.3	24	1010.3	24	1697.6	24	32.7	24	7135.1	24
11	27	92	1820.7	24	2639.6	24	662.9	24	1499.3	24	29.6	24	6089.6	24



MO	DA	YR	COMP.		LIGHTS		HVAC		UTIL.		VID.		W.B.E.	
11	28	92	1869.6	24	2849.7	24	656.7	24	1697.0	24	29.3	24	6540.2	24
11	29	92	2034.1	24	2941.4	24	809.6	24	1743.4	24	36.1	24	6995.7	24
11	30	92	2128.7	24	2906.3	24	1027.0	24	1740.4	24	40.1	24	7269.6	24
12	01	92	2119.4	24	3186.2	24	1007.3	24	1727.2	24	38.3	24	7507.4	24
12	02	92	2180.1	24	3035.7	24	1033.0	24	1711.0	24	46.5	24	7427.1	24
12	03	92	2123.9	24	2969.8	24	1022.6	24	1725.3	24	38.0	24	7308.9	24
12	04	92	2160.5	24	2912.6	24	1083.9	24	1738.6	24	42.9	24	7362.7	24
12	05	92	2265.6	24	3084.9	24	1252.5	24	1752.2	24	41.1	24	7822.5	24
12	06	92	2064.2	24	3051.2	24	1064.6	24	1750.9	24	29.1	24	7398.1	24
12	07	92	2025.7	24	2941.6	24	945.3	24	1707.9	24	29.4	24	7087.7	24
12	08	92	2100.5	24	2907.3	24	1084.4	24	1741.1	24	34.4	24	7300.5	24
12	09	92	2105.9	24	2917.9	24	1238.8	24	1751.8	24	33.7	24	7481.5	24
12	10	92	2220.0	24	2944.5	24	1295.7	24	1792.6	24	41.7	24	7720.0	24
12	11	92	2160.0	24	2949.2	24	1245.2	24	1821.5	24	42.7	24	7643.1	24
12	12	92	2148.3	24	3020.5	24	1289.2	24	1730.2	24	47.0	24	7655.5	24
12	13	92	2228.5	24	2989.7	24	1390.7	24	1759.9	24	59.1	24	7836.0	24
12	14	92	2403.3	24	2928.9	24	1438.5	24	1785.3	24	64.9	24	8023.3	24
12	15	92	2194.5	24	3023.5	24	1168.2	24	1800.6	24	32.1	24	7654.1	24
12	16	92	2045.6	24	2982.1	24	884.2	24	1775.1	24	31.8	24	7154.1	24
12	17	92	2095.6	24	3029.4	24	911.3	24	1765.1	24	32.7	24	7268.6	24
12	18	92	2060.2	24	2993.9	24	926.5	24	1786.2	24	33.5	24	7234.0	24
12	19	92	2144.1	24	3097.4	24	903.4	24	1754.0	24	40.2	24	7366.1	24
12	20	92	2412.8	24	3028.1	24	1228.2	24	1757.0	24	62.8	24	7893.3	24
12	21	92	2122.9	24	3355.1	24	954.1	24	1749.9	24	31.0	24	7649.2	24
12	22	92	2163.8	24	2993.4	24	856.4	24	1775.6	24	36.5	24	7256.4	24
12	23	92	2384.1	24	2980.1	24	1021.6	24	1787.5	24	54.7	24	7640.5	24
12	24	92	2426.1	24	2956.8	24	1231.8	24	1786.8	24	60.7	24	7868.7	24
12	28	92	2140.7	24	3014.7	24	692.5	24	1724.3	24	38.8	24	7039.4	24
12	29	92	2384.3	24	3382.7	24	1055.8	24	1678.3	24	57.1	24	7968.4	24
12	30	92	2553.2	24	3321.5	24	1290.6	24	1690.1	24	73.3	24	8322.7	24
12	31	92	2580.3	24	3307.0	24	1332.3	24	1713.1	24	82.5	24	8399.8	24
01	01	93	2359.6	24	2982.2	24	869.6	24	1716.4	24	53.9	24	7395.0	24

### E.1.2 Predictor Variable Data

The values listed are: outdoor dry-bulb temperature ( $^{\circ}\text{C}$ ), relative humidity (%), solar radiation ( $\text{W}/\text{m}^2$ ), enthalpy ( $\text{Btu}/\text{lbm}$  air), specific humidity ( $\text{kg}$  moisture/ $\text{kg}$  dry air), store sales ( $\text{\$/day}$ ). Of these, only temperature, specific humidity, solar radiation, and sales data are used as predictor variables. The columns adjacent to each load represent the number of hours of data used in each daily average calculation.

MO	DA	YR	TEMP.		R.H.		SOLAR		ENTH.		SP.HUM.		SALES	
01	02	92	12.44	24	71.4	24	143.2	24	19.5	24	0.006054	24	52269	24
01	03	92	13.47	17	56.0	17	203.1	19	18.8	17	0.005053	17	27658	24
01	04	92	13.84	24	44.8	24	165.9	24	17.8	24	0.003929	24	34465	24

MO	DA	YR	TEMP.	R.H.	SOLAR	ENTH.	SP.HUM.	SALES						
01	05	92	13.44	24	54.9	24	95.8	21	18.8	24	0.005058	24	45183	24
01	06	92	11.13	6	100.0	6	17.2	23	21.1	6	0.008067	6	47932	24
01	07	92	13.41	7	98.7	7	17.8	24	23.4	7	0.009257	7	44254	24
01	08	92	17.02	7	100.0	7	34.6	21	27.8	7	0.011886	7	42443	24
01	09	92	13.41	14	63.2	14	27.5	24	19.8	14	0.005950	14	37499	24
01	10	92	10.66	24	40.4	24	139.6	24	15.4	24	0.003000	24	33802	24
01	11	92	10.60	24	33.1	24	143.9	24	14.8	24	0.002463	24	38556	24
01	12	92	9.11	22	54.1	22	35.8	23	15.5	22	0.003768	22	38582	24
01	13	92	12.02	11	96.5	11	56.6	22	21.7	11	0.008264	11	58925	24
01	14	92	10.00	24	63.8	24	95.6	24	17.2	24	0.004900	24	40843	24
01	15	92	5.96	24	47.6	24	179.5	24	12.8	24	0.002521	24	58413	24
01	16	92	5.54	24	46.3	24	156.9	24	12.5	24	0.002417	24	36462	24
01	17	92	-0.17	24	38.9	24	90.5	24	8.9	24	0.001313	24	40259	24
01	18	92	4.16	22	73.3	22	19.4	24	13.4	22	0.003727	22	41671	24
01	19	92	3.31	5	95.6	5	16.0	24	13.8	5	0.004480	5	46977	24
01	20	92	5.00	24	59.9	24	183.4	24	12.9	24	0.002996	24	71531	24
01	21	92	7.78	24	49.7	24	177.5	24	14.1	24	0.002992	24	62412	24
01	22	92	8.35	18	66.1	18	21.4	24	16.0	18	0.004456	18	60920	24
01	23	92	17.01	14	43.5	14	171.8	24	20.3	14	0.004943	14	62156	24
01	24	92	10.21	24	34.7	24	193.9	24	14.7	24	0.002513	24	55119	24
01	25	92	11.77	24	35.6	24	191.7	24	15.6	24	0.002742	24	49353	24
01	26	92	13.79	24	55.8	24	151.7	24	19.2	24	0.005225	24	49962	24
01	27	92	12.53	21	93.3	21	23.3	23	21.9	21	0.008229	21	66100	24
01	28	92	11.63	10	100.0	10	25.7	21	21.6	10	0.008310	10	59130	24
01	29	92	10.46	21	99.6	21	20.8	24	20.4	21	0.007657	21	42410	24
01	30	92	10.63	20	99.3	20	22.2	24	20.5	20	0.007730	20	37637	24
01	31	92	15.49	17	58.9	17	173.4	24	20.8	17	0.006065	17	38596	24
02	01	92	16.02	24	48.9	24	199.7	24	19.7	24	0.004867	24	48345	24
02	02	92	16.58	24	39.9	24	151.7	24	19.4	24	0.004321	24	62038	24
02	03	92	14.78	24	58.8	24	55.9	24	20.4	24	0.005938	24	70772	24
02	04	92	12.90	11	95.0	11	9.3	24	22.5	11	0.008609	11	57757	24
02	05	92	10.30	17	99.9	17	9.4	24	20.3	17	0.007641	17	50132	24
02	06	92	7.15	24	78.6	24	74.9	24	15.8	24	0.004763	24	43763	24
02	07	92	8.82	24	51.7	24	202.8	24	14.9	24	0.003242	24	43452	24
02	08	92	9.59	24	52.7	24	201.9	24	15.6	24	0.003650	24	46598	24
02	09	92	9.80	24	40.2	24	201.5	24	14.7	24	0.002721	24	52333	24
02	10	92	9.80	24	60.4	24	37.5	24	16.5	24	0.004367	24	66768	24
02	11	92	13.91	24	71.8	24	125.2	24	21.3	24	0.007142	24	52497	24
02	12	92	15.07	22	98.2	22	35.3	24	25.2	22	0.010264	22	44224	24
02	13	92	18.45	18	90.9	18	73.4	24	28.3	18	0.011772	18	41376	24
02	14	92	20.00	22	86.4	22	101.7	24	29.5	22	0.012223	22	36843	24
02	15	92	20.61	24	90.5	24	74.3	24	31.1	24	0.013404	24	51440	24
02	16	92	19.71	20	53.9	20	211.7	24	24.0	20	0.007335	20	72941	24
02	17	92	16.35	24	63.9	24	144.5	24	22.0	24	0.006808	24	63136	24
02	18	92	17.84	24	52.4	24	201.9	24	21.5	24	0.005742	24	53287	24
02	19	92	16.63	24	22.6	24	224.1	24	17.4	24	0.002475	24	46852	24
02	20	92	15.94	24	22.3	24	235.1	24	16.9	24	0.002271	24	41083	24
02	21	92	15.31	24	29.3	24	230.9	24	17.3	24	0.002888	24	37767	24
02	22	92	15.34	24	76.0	24	127.4	24	22.8	24	0.007975	24	41908	24
02	23	92	18.10	21	68.4	21	181.4	24	24.5	21	0.008424	21	51263	24
02	24	92	17.75	24	73.4	24	225.4	24	24.8	24	0.008792	24	64319	24

MO	DA	YR	TEMP.	R.H.	SOLAR	ENTH.	SP.HUM.	SALES						
02	25	92	15.44	13	98.5	13	32.0	24	25.7	13	0.010569	13	54423	24
02	26	92	8.52	24	84.5	24	30.4	24	17.6	24	0.005867	24	38510	24
02	27	92	8.74	24	45.9	24	233.9	24	14.5	24	0.002908	24	45092	24
02	28	92	14.59	24	40.6	24	233.9	24	18.0	24	0.003804	24	43855	24
02	29	92	17.13	24	39.1	24	241.6	24	19.3	24	0.003996	24	40609	24
03	01	92	20.48	24	26.8	24	244.9	24	20.1	24	0.003404	24	50371	24
03	02	92	19.44	24	42.0	24	212.4	24	22.0	24	0.005558	24	65532	24
03	03	92	18.75	24	86.5	24	75.9	24	28.0	24	0.011342	24	56897	24
03	04	92	19.57	23	91.7	23	34.9	24	29.9	23	0.012778	23	51111	24
03	05	92	16.89	16	93.0	16	80.0	24	26.7	16	0.010919	16	45414	24
03	06	92	21.60	19	67.9	19	202.4	24	28.1	19	0.010326	19	42669	24
03	07	92	23.42	20	42.1	20	252.4	24	24.6	20	0.006355	20	44937	24
03	08	92	21.28	24	59.7	24	219.6	24	26.4	24	0.008871	24	49583	24
03	09	92	20.29	24	87.6	24	53.8	24	30.2	24	0.012758	24	65122	24
03	10	92	20.22	24	75.5	24	79.1	24	28.5	24	0.011229	24	55794	24
03	11	92	7.87	24	32.4	24	170.3	24	13.1	24	0.002025	24	41433	24
03	12	92	7.38	24	36.9	24	113.6	24	13.1	24	0.002213	24	42030	24
03	13	92	12.84	24	37.2	24	233.6	24	16.3	24	0.003008	24	41883	24
03	14	92	14.62	24	40.0	24	256.0	24	18.0	24	0.003825	24	43540	24
03	15	92	18.21	24	49.1	24	260.9	24	21.0	24	0.005154	24	52695	24
03	16	92	19.62	24	60.1	24	252.3	24	24.4	24	0.007721	24	54699	24
03	17	92	19.35	24	69.1	24	196.5	24	25.8	24	0.009063	24	37271	24
03	18	92	20.03	24	87.0	24	69.0	23	29.7	24	0.012400	24	36194	24
03	19	92	22.72	24	53.0	24	256.9	24	26.2	24	0.008125	24	35736	24
03	20	92	15.69	24	43.4	24	269.2	24	19.2	24	0.004529	24	35581	24
03	21	92	14.73	24	46.5	24	230.8	24	18.6	24	0.004363	24	39023	24
03	22	92	15.96	24	78.7	24	67.0	24	24.0	24	0.008771	24	41892	24
03	23	92	14.72	16	60.9	16	179.5	24	20.9	16	0.006456	16	53614	24
03	24	92	10.63	24	46.9	24	273.4	24	15.6	24	0.003238	24	58294	24
03	25	92	15.29	24	57.6	24	192.3	24	20.6	24	0.005967	24	55830	24
03	26	92	19.94	24	53.4	24	274.7	24	23.5	24	0.006767	24	45762	24
03	27	92	19.49	24	47.2	24	257.8	24	22.6	24	0.006083	24	43797	24
03	28	92	19.49	22	61.5	22	165.3	24	24.7	22	0.008018	22	43336	24
03	29	92	16.80	21	92.5	21	39.7	23	26.6	21	0.010805	21	56428	24
03	30	92	21.66	14	67.4	14	161.3	24	28.5	14	0.010607	14	73378	24
03	31	92	15.30	24	56.6	24	246.8	24	20.4	24	0.005792	24	55143	24
04	01	92	16.16	24	56.1	24	315.7	19	20.9	24	0.005917	24	43595	24
04	02	92	15.52	24	57.4	24	158.8	24	21.0	24	0.006213	24	46705	24
04	03	92	9.11	24	50.5	24	51.4	24	15.2	24	0.003479	24	50487	24
04	04	92	12.68	24	44.9	24	290.8	24	16.6	24	0.003354	24	47221	24
04	05	92	16.14	24	50.9	24	254.2	24	20.1	24	0.005146	24	55366	24
04	06	92	13.77	24	93.2	24	38.1	24	23.2	24	0.008954	24	66183	24
04	07	92	18.10	19	71.2	19	166.1	24	24.8	19	0.008716	19	59743	24
04	08	92	19.71	22	70.0	22	276.8	22	26.3	22	0.009359	22	51166	24
04	09	92	21.41	23	74.3	23	220.9	24	29.0	23	0.011213	23	42373	24
04	10	92	20.38	24	70.3	24	232.4	24	27.1	24	0.009888	24	43863	24
04	11	92	21.20	24	70.6	24	221.7	24	28.0	24	0.010379	24	45802	24
04	12	92	22.43	24	73.2	24	223.9	24	30.1	24	0.011746	24	57812	24
04	13	92	23.95	24	66.0	24	185.0	24	30.4	24	0.011488	24	72263	24
04	14	92	24.16	23	64.5	23	227.8	24	30.3	23	0.011304	23	58135	24
04	15	92	23.70	24	61.7	24	250.6	24	29.5	24	0.010729	24	46424	24

MO	DA	YR	TEMP.	R.H.	SOLAR	ENTH.	SP.HUM.	SALES						
04	16	92	22.44	24	72.6	24	165.1	24	30.1	24	0.011750	24	45769	24
04	17	92	22.46	24	72.6	24	224.7	24	29.8	24	0.011525	24	43568	24
04	18	92	19.47	24	95.0	24	31.2	24	30.3	24	0.013188	24	48080	24
04	19	92	20.01	24	83.8	24	159.6	24	29.0	24	0.011796	24	59401	24
04	20	92	20.42	24	88.0	24	82.8	24	30.4	24	0.012879	24	74431	24
04	21	92	18.35	23	57.1	23	276.2	24	22.8	23	0.006770	23	48574	24
04	22	92	19.63	24	43.5	24	280.6	24	22.4	24	0.005854	24	49824	24
04	23	92	21.24	24	54.2	24	304.2	24	25.1	24	0.007700	24	40793	24
04	24	92	22.70	24	78.3	24	193.4	24	31.3	24	0.012804	24	40374	24
04	25	92	25.10	24	77.9	24	184.8	24	34.8	24	0.014954	24	41631	24
04	26	92	20.36	24	49.5	24	184.8	24	24.1	24	0.007100	24	52156	24
04	27	92	19.88	24	33.5	24	302.0	24	20.9	24	0.004400	24	66003	24
04	28	92	19.89	24	46.0	24	284.9	24	22.9	24	0.006204	24	51858	24
04	29	92	21.40	24	54.8	24	296.2	24	25.3	24	0.007808	24	44616	24
04	30	92	21.83	24	69.2	24	173.0	24	28.7	24	0.010771	24	43656	24
05	01	92	18.70	24	79.0	24	101.1	24	26.8	24	0.010283	24	39765	24
05	02	92	22.23	24	70.3	24	220.5	24	29.1	24	0.010917	24	44178	24
05	03	92	23.32	24	71.0	24	214.6	24	30.7	24	0.011967	24	53980	24
05	04	92	23.91	24	71.8	24	207.4	24	31.5	24	0.012483	24	67225	24
05	05	92	22.54	24	75.4	24	135.4	24	30.8	24	0.012429	24	56160	24
05	06	92	24.10	24	50.3	24	301.8	24	26.7	24	0.007992	24	42034	24
05	07	92	20.20	24	37.7	24	297.6	24	22.1	24	0.005325	24	40809	24
05	08	92	17.12	24	32.5	24	311.0	24	18.6	24	0.003392	24	40341	24
05	09	92	19.18	24	34.2	24	303.5	24	20.6	24	0.004354	24	40684	24
05	10	92	19.77	24	56.8	24	219.9	24	24.4	24	0.007642	24	48262	24
05	11	92	21.44	24	76.3	24	120.2	24	29.9	24	0.011946	24	45175	24
05	12	92	24.27	24	77.6	24	151.5	24	33.6	24	0.014233	24	44819	24
05	13	92	25.98	24	71.2	24	216.3	24	34.5	24	0.014317	24	36189	24
05	14	92	25.02	24	70.7	24	170.4	24	33.3	24	0.013613	24	34348	24
05	15	92	25.48	24	71.0	24	252.9	24	33.6	24	0.013763	24	48965	24
05	16	92	21.83	24	85.7	24	51.3	24	32.0	24	0.013808	24	41857	24
05	17	92	21.68	24	94.3	24	75.3	24	33.3	24	0.015033	24	50204	24
05	18	92	21.66	24	93.5	24	85.7	24	33.2	24	0.014896	24	57443	24
05	19	92	22.16	19	89.3	19	147.0	24	33.0	19	0.014558	19	43706	24
05	20	92	22.80	24	81.9	24	221.1	24	32.1	24	0.013492	24	37987	24
05	21	92	22.66	24	84.7	24	214.7	24	32.5	24	0.013900	24	32731	24
05	22	92	22.37	21	85.6	21	171.8	24	32.4	21	0.013886	21	33194	24
05	23	92	23.20	24	71.8	24	229.7	24	30.5	24	0.011850	24	34790	24
05	24	92	25.26	22	61.0	22	271.9	24	30.8	22	0.011327	22	44959	24
05	25	92	25.42	24	65.5	24	235.4	24	32.3	24	0.012625	24	50769	24
05	26	92	24.32	24	68.2	24	264.9	24	31.4	24	0.012183	24	41147	24
05	27	92	22.87	24	75.9	24	205.1	24	31.3	24	0.012704	24	35637	24
05	28	92	22.89	24	69.5	24	190.2	24	30.1	24	0.011563	24	36912	24
05	29	92	21.29	24	85.3	24	155.3	24	31.0	24	0.013100	24	34181	24
05	30	92	16.48	24	71.2	24	88.7	24	23.4	24	0.008046	24	37340	24
05	31	92	18.99	24	67.4	24	199.7	24	25.3	24	0.008738	24	46956	24
06	01	92	19.57	24	89.1	24	71.4	24	29.6	24	0.012442	24	59234	24
06	02	92	23.43	16	81.2	16	178.7	24	33.1	16	0.014119	16	56838	24
06	03	92	22.86	24	73.4	24	215.6	24	30.6	24	0.012050	24	50567	24



MO	DA	YR	TEMP.	R.H.	SOLAR	ENTH.	SP.HUM.	SALES						
06	04	92	25.89	24	54.7	24	299.5	24	30.3	24	0.010588	24	41431	24
06	05	92	26.50	24	43.1	24	321.3	24	28.4	24	0.008588	24	41537	24
06	06	92	26.75	24	59.0	24	274.7	24	32.8	24	0.012508	24	39747	24
06	07	92	24.24	24	80.3	24	116.8	24	34.3	24	0.014913	24	43190	24
06	08	92	24.90	24	70.6	24	192.0	24	32.8	24	0.013258	24	58715	24
06	09	92	27.27	24	64.3	24	270.6	24	34.3	24	0.013642	24	44566	24
06	10	92	26.91	24	59.4	24	225.3	24	32.8	24	0.012492	24	40671	24
06	11	92	27.63	24	59.7	24	298.4	24	33.7	24	0.012946	24	38544	24
06	12	92	28.06	24	53.7	24	305.3	24	32.6	24	0.011779	24	38613	24
06	13	92	28.47	24	53.6	24	248.9	24	33.3	24	0.012317	24	35292	24
06	14	92	28.03	24	66.6	24	209.0	24	36.1	24	0.015008	24	42799	24
06	15	92	28.42	24	67.1	24	259.3	24	36.7	24	0.015367	24	50125	24
06	16	92	28.34	24	65.6	24	263.6	24	36.2	24	0.014979	24	42598	24
06	17	92	17.31	14	72.8	14	317.5	24	24.4	14	0.008643	14	38018	24
06	18	92	31.22	14	56.6	14	296.5	24	38.3	14	0.015743	14	40523	24
06	19	92	28.83	24	68.5	24	314.4	24	38.0	24	0.016350	24	37135	24
06	20	92	29.19	24	68.8	24	303.1	24	38.6	24	0.016813	24	41201	24
06	21	92	29.62	24	64.4	24	298.4	24	37.9	24	0.015975	24	49635	24
06	22	92	29.03	24	68.2	24	224.3	24	38.5	24	0.016750	24	41362	24
06	23	92	25.84	24	79.1	24	127.7	24	36.4	24	0.016192	24	37567	24
06	24	92	27.93	24	70.3	24	273.4	24	37.2	24	0.016038	24	37587	24
06	25	92	28.86	24	67.4	24	303.1	24	37.8	24	0.016242	24	35915	24
06	26	92	29.24	24	67.5	24	304.4	24	38.4	24	0.016583	24	35242	24
06	27	92	29.04	24	69.0	24	251.1	24	38.4	24	0.016713	24	41973	24
06	28	92	28.17	24	70.8	24	235.3	24	37.7	24	0.016408	24	48914	24
06	29	92	28.40	24	71.5	24	264.1	24	38.2	24	0.016779	24	41612	24
06	30	92	29.34	24	58.9	24	302.0	24	36.4	24	0.014758	24	38988	24
07	01	92	26.18	24	78.4	24	78.3	24	36.9	24	0.016458	24	39143	24
07	02	92	29.48	24	74.8	24	297.9	24	40.9	24	0.018788	24	44636	24
07	03	92	30.11	24	71.7	24	286.0	24	41.1	24	0.018733	24	51491	24
07	04	92	27.01	24	79.9	24	182.5	24	38.4	24	0.017521	24	58665	24
07	05	92	27.69	24	73.5	24	268.7	24	37.7	24	0.016538	24	48189	24
07	06	92	28.88	24	65.1	24	312.1	24	36.9	24	0.015379	24	38661	24
07	07	92	28.62	24	67.9	24	309.0	24	37.2	24	0.015775	24	41623	24
07	08	92	28.66	24	69.6	24	304.5	24	37.9	24	0.016388	24	42114	24
07	09	92	28.84	24	69.0	24	288.7	24	38.0	24	0.016367	24	40214	24
07	10	92	28.74	24	69.2	24	297.9	24	37.9	24	0.016350	24	44812	24
07	11	92	28.93	24	69.1	24	292.3	24	38.2	24	0.016554	24	43211	24
07	12	92	28.72	24	71.4	24	270.3	24	38.5	24	0.016950	24	56078	24
07	13	92	29.11	24	69.0	24	290.8	24	38.4	24	0.016671	24	41485	24
07	14	92	28.36	24	70.6	24	286.5	24	37.8	24	0.016417	24	39989	24
07	15	92	29.10	24	69.7	24	270.5	24	38.7	24	0.016933	24	38304	24
07	16	92	29.30	24	71.5	24	268.9	24	39.6	24	0.017663	24	38075	24
07	17	92	29.55	24	65.7	24	287.3	24	38.3	24	0.016363	24	38666	24
07	18	92	28.17	24	72.4	24	233.8	24	38.0	24	0.016667	24	39708	24
07	19	92	25.54	24	77.0	24	212.1	24	35.4	24	0.015379	24	54431	24
07	20	92	24.72	24	85.1	24	145.6	24	36.0	24	0.016288	24	45730	24
07	21	92	24.02	24	88.0	24	100.4	24	35.6	24	0.016188	24	37589	24
07	22	92	25.77	24	80.8	24	167.5	24	36.6	24	0.016333	24	39360	24

MO	DA	YR	TEMP.	R.H.	SOLAR	ENTH.	SP.HUM.	SALES						
07	23	92	26.96	24	78.5	24	176.4	24	37.9	24	0.017063	24	35659	24
07	24	92	28.01	24	77.2	24	239.6	24	39.2	24	0.017792	24	36498	24
07	25	92	28.52	24	74.9	24	229.9	24	39.3	24	0.017671	24	40353	24
07	26	92	28.51	24	75.5	24	226.8	24	39.5	24	0.017854	24	49018	24
07	27	92	29.00	24	72.7	24	279.9	24	39.4	24	0.017567	24	40168	24
07	28	92	29.15	24	70.5	24	290.1	24	38.9	24	0.017146	24	38869	24
07	29	92	29.06	24	68.1	24	279.3	24	38.2	24	0.016508	24	34323	24
07	30	92	28.85	24	68.4	24	283.7	24	37.8	24	0.016229	24	33375	24
07	31	92	29.26	24	69.4	24	271.4	24	38.8	24	0.016942	24	35801	24
08	01	92	29.14	24	68.2	24	233.2	24	38.3	24	0.016525	24	44904	24
08	02	92	29.63	24	64.2	24	299.6	24	37.8	24	0.015858	24	50498	24
08	03	92	27.20	24	72.8	24	247.0	24	36.6	24	0.015771	24	40437	24
08	04	92	26.20	24	75.3	24	252.9	24	35.9	24	0.015579	24	38520	24
08	05	92	28.26	24	71.0	24	267.2	24	37.6	24	0.016271	24	37345	24
08	06	92	28.81	24	69.4	24	281.7	24	38.0	24	0.016446	24	37026	24
08	07	92	29.15	23	69.0	23	264.6	23	38.4	23	0.016683	23	37906	24
08	08	92	29.31	24	70.2	24	284.9	24	39.1	24	0.017171	24	37023	24
08	09	92	29.43	24	69.5	24	274.6	24	39.0	24	0.017113	24	53798	24
08	10	92	29.45	24	69.5	24	282.9	24	39.1	24	0.017163	24	38378	24
08	11	92	29.89	24	68.2	24	285.7	24	39.4	24	0.017217	24	33591	24
08	12	92	27.64	24	74.8	24	182.8	24	37.9	24	0.016825	24	33516	24
08	13	92	26.42	24	77.8	24	179.3	24	37.1	24	0.016513	24	44120	24
08	14	92	27.48	23	72.3	23	232.4	23	36.9	23	0.015974	23	40049	24
08	15	92	27.98	24	61.5	24	251.4	24	34.9	24	0.013917	24	46648	24
08	16	92	25.79	24	63.9	24	204.7	24	32.7	24	0.012788	24	56372	24
08	17	92	23.98	24	54.1	24	294.2	24	28.2	24	0.009438	24	45452	24
08	18	92	23.93	24	55.3	24	278.6	24	28.4	24	0.009642	24	37492	24
08	19	92	24.93	24	54.7	24	289.1	24	29.4	24	0.010150	24	36651	24
08	20	92	23.63	24	68.3	24	158.0	24	31.1	24	0.012175	24	35180	24
08	21	92	25.24	24	64.5	24	246.9	24	31.8	24	0.012225	24	38076	24
08	22	92	27.05	24	57.7	24	262.0	24	32.5	24	0.012092	24	42451	24
08	23	92	27.55	24	59.1	24	264.3	24	33.5	24	0.012863	24	60588	24
08	24	92	26.36	24	73.2	24	238.8	24	35.5	24	0.015129	24	52830	24
08	25	92	27.39	24	68.7	24	260.6	24	35.8	24	0.014967	24	45834	24
08	26	92	28.45	24	67.0	24	257.3	24	36.6	24	0.015238	24	47476	24
08	27	92	29.92	24	58.4	24	254.0	24	36.6	24	0.014692	24	48432	24
08	28	92	25.95	24	68.1	24	204.6	24	33.9	24	0.013808	24	47952	24
08	29	92	25.20	24	53.8	24	296.0	24	29.1	24	0.009763	24	56090	24
08	30	92	26.66	24	48.2	24	289.9	24	30.1	24	0.010046	24	80680	24
08	31	92	26.18	24	57.7	24	288.1	24	31.4	24	0.011429	24	78127	24
09	01	92	25.16	24	78.5	24	141.4	24	35.3	24	0.015392	24	66074	24
09	02	92	26.63	24	76.4	24	212.7	24	36.7	24	0.016079	24	48114	24
09	03	92	28.69	24	71.2	24	262.1	24	38.3	24	0.016729	24	47895	24
09	04	92	25.87	24	83.6	24	146.5	24	37.5	24	0.017154	24	43742	24
09	05	92	25.64	24	82.1	24	188.4	24	36.7	24	0.016463	24	54310	24
09	06	92	27.20	24	77.5	24	229.3	24	37.7	24	0.016779	24	72476	24
09	07	92	27.89	24	76.1	24	191.0	24	38.5	24	0.017213	24	53159	24
09	08	92	28.08	24	74.7	24	234.1	24	38.3	24	0.016950	24	49219	24
09	09	92	28.40	24	72.1	24	213.1	24	38.1	24	0.016688	24	42849	24

MO	DA	YR	TEMP.	R.H.	SOLAR	ENTH.	SP.HUM.	SALES						
09	10	92	27.97	24	74.9	24	222.9	24	38.2	24	0.016979	24	41448	24
09	11	92	27.46	24	72.6	24	223.8	24	36.8	24	0.015896	24	43223	24
09	12	92	26.50	24	71.0	24	247.6	24	35.1	24	0.014713	24	55468	24
09	13	92	27.38	24	66.3	24	239.7	24	35.2	24	0.014471	24	66193	24
09	14	92	26.06	24	78.5	24	151.5	24	36.4	24	0.016104	24	61835	24
09	15	92	26.08	24	79.0	24	193.4	24	36.5	24	0.016192	24	46402	24
09	16	92	26.58	24	68.1	24	222.3	24	34.4	24	0.014050	24	46575	24
09	17	92	26.74	24	63.7	24	227.4	24	33.9	24	0.013508	24	40672	24
09	18	92	27.27	24	71.0	24	208.8	24	36.3	24	0.015488	24	38694	24
09	19	92	28.25	24	70.6	24	225.4	24	37.4	24	0.016071	24	53301	24
09	20	92	28.65	24	69.1	24	232.6	24	37.5	24	0.016058	24	62797	24
09	21	92	28.45	24	72.2	24	221.8	24	38.2	24	0.016733	24	56851	24
09	22	92	28.04	24	74.5	24	177.1	24	38.4	24	0.017108	24	43350	24
09	23	92	25.95	24	70.8	24	228.4	24	34.4	24	0.014317	24	38433	24
09	24	92	23.37	24	57.5	24	216.0	24	28.3	24	0.009788	24	37375	24
09	25	92	21.41	24	42.3	24	219.1	24	23.5	24	0.006163	24	40924	24
09	26	92	24.06	24	59.2	24	219.3	24	29.9	24	0.010904	24	51364	24
09	27	92	25.23	24	77.7	24	155.8	24	34.9	24	0.014996	24	63716	24
09	28	92	25.21	24	72.0	24	216.7	21	33.7	24	0.013963	24	52089	24
09	29	92	22.63	24	59.5	24	243.1	24	27.6	24	0.009388	24	44666	24
09	30	92	22.18	24	49.0	24	255.1	24	25.4	24	0.007583	24	42244	24
10	01	92	19.49	24	38.0	24	262.9	24	21.1	24	0.004750	24	41562	24
10	02	92	20.21	24	43.0	24	254.9	24	22.6	24	0.005833	24	49937	24
10	03	92	21.08	24	46.8	24	249.4	24	24.0	24	0.006696	24	64584	24
10	04	92	21.85	24	45.8	24	247.0	24	24.4	24	0.006833	24	71837	24
10	05	92	23.45	24	41.0	24	248.4	24	24.9	24	0.006604	24	59100	24
10	06	92	24.09	24	56.5	24	233.5	24	28.4	24	0.009592	24	46279	24
10	07	92	23.03	24	62.1	24	198.3	24	28.7	24	0.010288	24	39588	24
10	08	92	22.39	24	72.6	24	191.2	23	29.9	24	0.011654	24	37150	24
10	09	92	16.72	24	45.1	24	236.4	24	20.0	24	0.004850	24	40707	24
10	10	92	20.58	24	52.7	24	185.9	24	25.1	24	0.007971	24	49473	24
10	11	92	24.76	24	74.8	24	160.7	24	33.4	24	0.013817	24	61461	24
10	12	92	21.97	24	41.1	24	236.0	24	23.8	24	0.006242	24	53179	24
10	13	92	22.72	24	50.7	24	230.0	24	26.2	24	0.008117	24	45195	24
10	14	92	22.89	24	61.1	24	233.8	24	28.2	24	0.009867	24	39051	24
10	15	92	24.16	24	70.0	24	188.8	24	31.7	24	0.012517	24	38632	24
10	16	92	25.37	24	78.0	24	110.9	24	35.4	24	0.015413	24	40963	24
10	17	92	22.23	24	84.9	24	75.9	24	32.6	24	0.014129	24	53346	24
10	18	92	18.62	24	84.9	24	55.1	24	27.8	24	0.011163	24	59250	24
10	19	92	19.07	24	78.8	24	111.2	24	27.2	24	0.010458	24	50938	24
10	20	92	18.63	23	60.4	23	213.8	23	23.8	23	0.007574	23	43268	24
10	21	92	21.09	24	67.9	24	152.5	24	27.7	24	0.010096	24	38081	24
10	22	92	21.94	24	74.7	24	177.4	24	29.8	24	0.011700	24	36423	24
10	23	92	22.22	24	76.9	24	158.7	20	30.6	24	0.012338	24	42615	24
10	24	92	23.17	24	61.3	24	194.2	24	28.4	24	0.009904	24	56413	24
10	25	92	23.85	24	56.7	24	168.6	24	28.6	24	0.009854	24	63133	24
10	26	92	25.59	24	48.6	24	186.9	24	28.9	24	0.009400	24	57131	24
10	27	92	24.90	24	57.1	24	183.7	24	30.1	24	0.010767	24	48289	24
10	28	92	21.92	24	67.0	24	186.6	24	28.5	24	0.010504	24	40590	24

MO	DA	YR	TEMP.	R.H.	SOLAR	ENTH.	SP.HUM.	SALES						
10	29	92	21.35	24	72.3	24	166.7	24	28.6	24	0.010858	24	38700	24
10	30	92	24.18	24	77.0	24	130.4	24	33.2	24	0.013908	24	39742	24
10	31	92	21.92	24	86.2	24	108.2	24	32.2	24	0.013883	24	48077	24
11	01	92	26.08	24	78.4	24	149.2	24	36.3	24	0.016021	24	61473	24
11	02	92	20.53	23	71.0	23	136.4	23	27.9	23	0.010530	23	54009	24
11	03	92	19.26	24	50.5	24	186.8	24	22.9	24	0.006479	24	47988	24
11	04	92	18.93	24	70.6	24	84.8	24	26.4	24	0.009767	24	48614	24
11	05	92	8.61	24	61.2	24	46.5	24	15.7	24	0.004121	24	45789	24
11	06	92	8.07	24	54.6	24	131.7	24	14.7	24	0.003446	24	45998	24
11	07	92	9.72	24	51.6	24	126.8	24	15.7	24	0.003629	24	59680	24
11	08	92	11.86	24	50.9	24	176.9	24	17.1	24	0.004058	24	62486	24
11	09	92	15.58	24	71.0	24	49.4	24	22.9	24	0.007908	24	54927	24
11	10	92	20.92	24	78.0	24	97.5	24	29.3	24	0.011679	24	40104	24
11	11	92	20.45	24	93.2	24	16.2	24	31.4	24	0.013796	24	41942	24
11	12	92	21.76	24	93.6	24	33.6	24	33.4	24	0.015054	24	39538	24
11	13	92	14.22	24	65.8	24	172.7	24	20.7	24	0.006508	24	44255	24
11	14	92	11.83	24	55.9	24	171.0	24	17.5	24	0.004471	24	47144	24
11	15	92	13.64	24	51.4	24	163.9	24	18.5	24	0.004696	24	58488	24
11	16	92	14.07	24	61.5	24	128.1	24	20.0	24	0.005883	24	52322	24
11	17	92	16.01	24	63.4	24	157.0	24	21.9	24	0.006817	24	44243	24
11	18	92	17.43	24	83.7	24	131.0	24	26.1	24	0.010121	24	40141	24
11	19	92	18.44	24	92.2	24	24.2	24	28.6	24	0.011988	24	36926	24
11	20	92	18.56	24	93.9	24	12.4	24	28.9	24	0.012296	24	41905	24
11	25	92	13.45	24	70.7	24	96.3	24	20.4	24	0.006492	24	60662	24
11	26	92	7.69	24	54.9	24	120.8	24	14.6	24	0.003438	24	60520	24
11	27	92	3.88	24	67.7	24	94.4	24	12.7	24	0.003263	24	19315	24
11	28	92	3.93	24	62.8	24	155.1	24	12.4	24	0.002917	24	29577	24
11	29	92	7.64	24	53.8	24	157.6	24	14.3	24	0.003229	24	42327	24
11	30	92	11.02	24	71.3	24	130.6	24	18.5	24	0.005704	24	45851	24
12	01	92	10.52	24	59.6	24	122.3	24	17.0	24	0.004533	24	50655	24
12	02	92	13.68	24	52.5	24	150.6	24	18.8	24	0.004913	24	47621	24
12	03	92	11.58	24	42.6	24	155.1	24	16.1	24	0.003317	24	40704	24
12	04	92	13.86	24	63.7	24	75.5	24	20.7	24	0.006629	24	44778	24
12	05	92	13.49	24	79.0	24	21.0	24	22.1	24	0.007992	24	55907	24
12	06	92	6.05	24	72.0	24	14.2	24	14.5	24	0.004000	24	67297	24
12	07	92	5.90	24	88.0	24	41.9	24	15.4	24	0.004942	24	54821	24
12	08	92	8.82	24	83.3	24	137.9	24	17.4	24	0.005621	24	43871	24
12	09	92	9.00	24	83.3	24	58.6	24	17.6	24	0.005729	24	40723	24
12	10	92	14.77	24	68.7	24	146.9	24	21.1	24	0.006613	24	40936	24
12	11	92	14.70	24	46.1	24	146.9	24	18.8	24	0.004529	24	41013	24
12	12	92	12.59	24	43.8	24	132.9	24	17.0	24	0.003729	24	47500	24
12	13	92	15.52	24	78.1	24	69.4	24	23.6	24	0.008575	24	62283	24
12	14	92	19.84	24	84.5	24	16.7	24	29.2	24	0.011992	24	44042	24
12	15	92	9.83	24	95.3	24	8.1	24	19.9	24	0.007479	24	38146	24
12	16	92	7.68	24	83.5	24	102.7	24	16.4	24	0.005175	24	39142	24
12	17	92	9.37	24	82.7	24	67.7	24	17.9	24	0.005821	24	45519	24
12	18	92	8.82	24	73.8	24	126.8	24	16.7	24	0.004908	24	46625	24
12	19	92	11.00	24	82.3	24	99.4	24	19.6	24	0.006742	24	44230	24
12	20	92	18.70	24	97.1	24	16.3	24	29.9	24	0.013083	24	52712	24

MO	DA	YR	TEMP.	R.H.	SOLAR	ENTH.	SP.HUM.	SALES						
12	21	92	7.85	24	97.4	24	13.3	24	17.8	24	0.006354	24	44942	24
12	22	92	9.94	24	94.6	24	61.1	24	19.5	24	0.007096	24	42128	24
12	23	92	16.59	24	99.6	24	31.5	24	27.3	24	0.011592	24	44006	24
12	24	92	18.25	24	97.8	24	21.9	24	29.3	24	0.012692	24	52482	24
12	28	92	11.97	24	90.7	24	47.9	24	21.1	24	0.007750	24	22294	24
12	29	92	17.66	24	98.9	24	17.6	24	28.7	24	0.012396	24	30526	24
12	30	92	21.26	24	93.7	24	51.3	24	32.6	24	0.014533	24	28453	24
12	31	92	21.54	24	94.0	24	73.5	24	33.1	24	0.014854	24	36527	24
01	01	93	14.35	24	93.5	24	37.1	24	25.0	24	0.010333	24	59269	24

## E.2 STATISTICAL ANALYSIS ROUTINE

```

data one;
infile '901siadj.day';
input site mo da yr greg julian hr
      comp hrs9 lght hrs11 hvac hrs13 util hrs15 vid hrs17 whb hrs19
      temp hrs21 RH hrs23 sol hrs25 enth hrs27 SH hrs29 wind hrs31
      tin hrs33 RHin hrs35 sales hrs37;
if SH<=0 then delete;
if temp<=-20 then delete;
if sol<=0 then delete;
if temp<=18.66 then delete;
Run;

proc corr;
var whb temp SH sol sales;
with whb temp SH sol sales;
run;
proc princomp out=prin;
var temp SH sol;
run;
data two;
merge one prin;
run;
proc reg;
model whb=prin1 prin2 prin3 / selection = rsquare RMSE;
run;
proc reg;
model whb=prin1 prin2 prin3;
run;
proc reg;
model whb=prin1 prin3;
run;
proc reg;
model whb=prin1 prin2;
run;
proc reg;
model whb=temp SH sol;
run;

proc corr;
var comp temp SH sol sales;
with comp temp SH sol sales;
run;
proc reg;
model comp=prin1 prin2 prin3 / selection = rsquare RMSE;
run;
proc reg;
model comp=prin1 prin2 prin3;
run;
proc reg;
model comp=prin1 prin3;
run;
proc reg;
model comp=prin1 prin2;
run;

```

```

proc reg;
model comp=temp SH sol;
run;

proc corr;
var hvac temp SH sol sales;
with hvac temp SH sol sales;
run;
proc reg;
model hvac=prin1 prin2 prin3 / selection = rsquare RMSE;
run;
proc reg;
model hvac=prin1 prin2 prin3;
run;
proc reg;
model hvac=prin1 prin3;
run;
proc reg;
model hvac=prin1 prin2;
run;
proc reg;
model hvac=temp SH sol;
run;

/*-----*/
data three;
infile '901siadj.day';
input site mo da yr greg julian hr comp hrs9 lght hrs11 hvac hrs13 util
hrs15 vid hrs17 whb hrs19 temp hrs21 RH hrs23 sol hrs25 enth hrs27 SH
hrs29 wind hrs31 tin hrs33 RHin hrs35 sales hrs37;
if SH<=0 then delete;
if temp<=-20 then delete;
if sales<=0 then delete;
if temp>18.66 then delete;
run;

proc corr;
var whb temp SH sol sales;
with whb temp SH sol sales;
run;
proc princomp out=prin;
var temp SH sales;
run;
data four;
merge three prin;
run;
proc reg;
model whb=prin1 prin2 prin3 / selection = rsquare RMSE;
run;
proc reg;
model whb=prin1 prin2 prin3;
run;
proc reg;
model whb=prin1 prin3;
run;
proc reg;

```

```
model whb=prin1 prin2;
run;
proc reg;
model whb=temp SH sales;
run;

proc corr;
var comp temp SH sol sales;
with comp temp SH sol sales;
run;
proc reg;
model comp=prin1 prin2 prin3 / selection = rsquare RMSE;
run;
proc reg;
model comp=prin1 prin2 prin3;
run;
proc reg;
model comp=prin1 prin3;
run;
proc reg;
model comp=prin1 prin2;
run;

proc corr;
var hvac temp SH sol sales;
with hvac temp SH sol sales;
run;
proc reg;
model hvac=prin1 prin2 prin3 / selection = rsquare RMSE;
run;
proc reg;
model hvac=prin1 prin2 prin3;
run;
proc reg;
model hvac=prin1 prin3;
run;
proc reg;
model hvac=prin1 prin2;
run;
```



### E.3 ANALYSIS OUTPUT

#### Correlation Analysis

5 'WITH' Variables: WHB      TEMP      SH      SOL      SALES  
 5 'VAR' Variables: WHB      TEMP      SH      SOL      SALES

#### Simple Statistics

Variable	N	Mean	Std Dev	Sum	Minimum	Maximum
WHB	231	9043	674.1137	2088925	7215	10099
TEMP	231	24.6577	3.3730	5696	18.7035	31.2226
SH	231	0.0130	0.003472	2.9971	0.003404	0.0188
SOL	231	212.4719	70.6488	49081	16.1967	321.3380
SALES	231	46462	9628	10732607	28453	80680

Pearson Correlation Coefficients / Prob > |R| under Ho: Rho=0 / N = 231

	WHB	TEMP	SH	SOL	SALES
WHB	1.00000 0.0	0.92328 0.0001	0.72268 0.0001	0.45866 0.0001	-0.15642 0.0174
TEMP	0.92328 0.0001	1.00000 0.0	0.75901 0.0001	0.54079 0.0001	-0.18424 0.0050
SH	0.72268 0.0001	0.75901 0.0001	1.00000 0.0	-0.01534 0.8167	-0.20623 0.0016
SOL	0.45866 0.0001	0.54079 0.0001	-0.01534 0.8167	1.00000 0.0	-0.12055 0.0674
SALES	-0.15642 0.0174	-0.18424 0.0050	-0.20623 0.0016	-0.12055 0.0674	1.00000 0.0

#### Principal Component Analysis

231 Observations  
 3 Variables

#### Simple Statistics

	TEMP	SH	SOL
Mean	24.65769351	0.0129744643	212.4719346
Std	3.37304191	0.0034717717	70.6487890

#### Correlation Matrix

	TEMP	SH	SOL
TEMP	1.0000	0.7590	0.5408
SH	0.7590	1.0000	-.0153
SOL	0.5408	-.0153	1.0000

#### Eigenvalues of the Correlation Matrix

	Eigenvalue	Difference	Proportion	Cumulative
PRIN1	1.92475	0.910259	0.641585	0.64158
PRIN2	1.01450	0.953744	0.338165	0.97975
PRIN3	0.06075	.	0.020250	1.00000

## Eigenvectors

	PRIN1	PRIN2	PRIN3
TEMP	0.709840	0.005377	-.704342
SH	0.575892	-.580190	0.575958
SOL	0.405556	0.814463	0.414939

N = 231      Regression Models for Dependent Variable: WHB

Number in Model	R-square	Root MSE	Variables in Model
1	0.82166621	285.29629	PRIN1
1	0.03150684	664.85598	PRIN3
1	0.00163801	675.03038	PRIN2
-----			
2	0.85317305	259.43735	PRIN1 PRIN3
2	0.82330422	284.60512	PRIN1 PRIN2
2	0.03314486	665.74869	PRIN2 PRIN3
-----			
3	0.85481106	258.55377	PRIN1 PRIN2 PRIN3
-----			

Model: MODEL1  
Dependent Variable: WHB

## Analysis of Variance

Source	DF	Sum of Squares	Mean Square	F Value	Prob>F
Model	3	89343758.203	29781252.734	445.493	0.0001
Error	227	15174961.682	66850.051464		
C Total	230	104518719.89			
Root MSE	258.55377	R-square	0.8548		
Dep Mean	9042.96636	Adj R-sq	0.8529		
C.V.	2.85917				

## Parameter Estimates

Variable	DF	Parameter Estimate	Standard Error	T for H0: Parameter=0	Prob >  T
INTERCEP	1	9042.966364	17.01158906	531.577	0.0001
PRIN1	1	440.446573	12.28851357	35.842	0.0001
PRIN2	1	-27.087370	16.92629796	-1.600	0.1109
PRIN3	1	-485.465871	69.16877701	-7.019	0.0001

Model: MODEL1  
Dependent Variable: WHB

## Analysis of Variance

Source	DF	Sum of Squares	Mean Square	F Value	Prob>F
Model	2	89172555.163	44586277.581	662.424	0.0001
Error	228	15346164.723	67307.740011		
C Total	230	104518719.89			
Root MSE	259.43735	R-square	0.8532		
Dep Mean	9042.96636	Adj R-sq	0.8519		
C.V.	2.86894				

## Parameter Estimates

Variable	DF	Parameter Estimate	Standard Error	T for H0: Parameter=0	Prob >  T
INTERCEP	1	9042.966364	17.06972460	529.766	0.0001
PRIN1	1	440.446573	12.33050844	35.720	0.0001
PRIN3	1	-485.465871	69.40515496	-6.995	0.0001

Model: MODEL1  
Dependent Variable: WHB

## Analysis of Variance

Source	DF	Sum of Squares	Mean Square	F Value	Prob>F
Model	2	86050703.388	43025351.694	531.177	0.0001
Error	228	18468016.498	81000.072359		
C Total	230	104518719.89			
Root MSE	284.60512	R-square	0.8233		
Dep Mean	9042.96636	Adj R-sq	0.8218		
C.V.	3.14725				

## Parameter Estimates

Variable	DF	Parameter Estimate	Standard Error	T for H0: Parameter=0	Prob >  T
INTERCEP	1	9042.966364	18.72564188	482.919	0.0001
PRIN1	1	440.446573	13.52667900	32.561	0.0001
PRIN2	1	-27.087370	18.63175703	-1.454	0.1474

Model: MODEL1  
 Dependent Variable: WHB

## Analysis of Variance

Source	DF	Sum of Squares	Mean Square	F Value	Prob>F
Model	3	89343758.203	29781252.734	445.493	0.0001
Error	227	15174961.682	66850.051464		
C Total	230	104518719.89			
Root MSE	258.55377	R-square	0.8548		
Dep Mean	9042.96636	Adj R-sq	0.8529		
C.V.	2.85917				

## Parameter Estimates

Variable	DF	Parameter Estimate	Standard Error	T for H0: Parameter=0	Prob >  T
INTERCEP	1	4432.135130	161.28889041	27.479	0.0001
TEMP	1	194.019275	14.67319550	13.223	0.0001
SH	1	-2950.290747	11992.930810	-0.246	0.8059
SOL	1	-0.635181	0.45616752	-1.392	0.1652

The SAS System 14:47 Thursday, July 15, 1993

## Correlation Analysis

5 'WITH' Variables: COMP TEMP SH SOL SALES  
 5 'VAR' Variables: COMP TEMP SH SOL SALES

## Simple Statistics

Variable	N	Mean	Std Dev	Sum	Minimum	Maximum
COMP	231	2936	224.9154	678132	2403	3305
TEMP	231	24.6577	3.3730	5696	18.7035	31.2226
SH	231	0.0130	0.003472	2.9971	0.003404	0.0188
SOL	231	212.4719	70.6488	49081	16.1967	321.3380
SALES	231	46462	9628	10732607	28453	80680

Pearson Correlation Coefficients / Prob &gt; |R| under Ho: Rho=0 / N = 231

	COMP	TEMP	SH	SOL	SALES
COMP	1.00000 0.0	0.87350 0.0001	0.73336 0.0001	0.47365 0.0001	-0.10004 0.1295
TEMP	0.87350 0.0001	1.00000 0.0	0.75901 0.0001	0.54079 0.0001	-0.18424 0.0050
SH	0.73336 0.0001	0.75901 0.0001	1.00000 0.0	-0.01534 0.8167	-0.20623 0.0016
SOL	0.47365 0.0001	0.54079 0.0001	-0.01534 0.8167	1.00000 0.0	-0.12055 0.0674
SALES	-0.10004 0.1295	-0.18424 0.0050	-0.20623 0.0016	-0.12055 0.0674	1.00000 0.0

N = 231 Regression Models for Dependent Variable: COMP

Number in Model	R-square	Root MSE	Variables in Model
1	0.79174976	102.86275	PRIN1
1	0.00120927	225.26962	PRIN2
1	0.00022241	225.38088	PRIN3
-----			
2	0.79295903	102.78834	PRIN1 PRIN2
2	0.79197218	103.03302	PRIN1 PRIN3
2	0.00143168	225.73796	PRIN2 PRIN3
-----			
3	0.79318145	102.95915	PRIN1 PRIN2 PRIN3
-----			

Model: MODEL1  
 Dependent Variable: COMP

## Analysis of Variance

Source	DF	Sum of Squares	Mean Square	F Value	Prob>F
Model	3	9228663.0362	3076221.0121	290.193	0.0001
Error	227	2406333.0824	10600.586266		
C Total	230	11634996.119			
Root MSE	102.95915	R-square	0.7932		
Dep Mean	2935.63742	Adj R-sq	0.7904		
C.V.	3.50722				

## Parameter Estimates

Variable	DF	Parameter Estimate	Standard Error	T for H0: Parameter=0	Prob >  T
INTERCEP	1	2935.637416	6.77421463	433.355	0.0001
PRIN1	1	144.253239	4.89343048	29.479	0.0001
PRIN2	1	-7.765249	6.74025071	-1.152	0.2505
PRIN3	1	13.608886	27.54381966	0.494	0.6217

Model: MODEL1  
 Dependent Variable: COMP

## Analysis of Variance

Source	DF	Sum of Squares	Mean Square	F Value	Prob>F
Model	2	9214593.2139	4607296.607	434.004	0.0001
Error	228	2420402.9046	10615.802213		
C Total	230	11634996.119			
Root MSE	103.03302	R-square	0.7920		
Dep Mean	2935.63742	Adj R-sq	0.7901		
C.V.	3.50973				

## Parameter Estimates

Variable	DF	Parameter Estimate	Standard Error	T for H0: Parameter=0	Prob >  T
INTERCEP	1	2935.637416	6.77907470	433.044	0.0001
PRIN1	1	144.253239	4.89694121	29.458	0.0001
PRIN3	1	13.608886	27.56358060	0.494	0.6220

Model: MODEL1  
Dependent Variable: COMP

## Analysis of Variance

Source	DF	Sum of Squares	Mean Square	F Value	Prob>F
Model	2	9226075.2601	4613037.63	436.616	0.0001
Error	228	2408920.8585	10565.442362		
C Total	230	11634996.119			
Root MSE	102.78834	R-square	0.7930		
Dep Mean	2935.63742	Adj R-sq	0.7911		
C.V.	3.50140				

## Parameter Estimates

Variable	DF	Parameter Estimate	Standard Error	T for H0: Parameter=0	Prob >  T
INTERCEP	1	2935.637416	6.76297610	434.075	0.0001
PRIN1	1	144.253239	4.88531220	29.528	0.0001
PRIN2	1	-7.765249	6.72906853	-1.154	0.2497

Model: MODEL1  
Dependent Variable: COMP

## Analysis of Variance

Source	DF	Sum of Squares	Mean Square	F Value	Prob>F
Model	3	9228663.0362	3076221.0121	290.193	0.0001
Error	227	2406333.0824	10600.586266		
C Total	230	11634996.119			
Root MSE	102.95915	R-square	0.7932		
Dep Mean	2935.63742	Adj R-sq	0.7904		
C.V.	3.50722				

## Parameter Estimates

Variable	DF	Parameter Estimate	Standard Error	T for H0: Parameter=0	Prob >  T
INTERCEP	1	1726.976173	64.22713112	26.889	0.0001
TEMP	1	27.503279	5.84303884	4.707	0.0001
SH	1	27484	4775.7259521	5.755	0.0001
SOL	1	0.818486	0.18165127	4.506	0.0001

## Correlation Analysis

5 'WITH' Variables: HVAC TEMP SH SOL SALES  
 5 'VAR' Variables: HVAC TEMP SH SOL SALES

## Simple Statistics

Variable	N	Mean	Std Dev	Sum	Minimum	Maximum
HVAC	231	1848	540.7833	426821	434.7230	2650
TEMP	231	24.6577	3.3730	5696	18.7035	31.2226
SH	231	0.0130	0.003472	2.9971	0.003404	0.0188
SOL	231	212.4719	70.6488	49081	16.1967	321.3380
SALES	231	46462	9628	10732607	28453	80680

Pearson Correlation Coefficients / Prob > |R| under Ho: Rho=0 / N = 231

	HVAC	TEMP	SH	SOL	SALES
HVAC	1.00000 0.0	0.87736 0.0001	0.66837 0.0001	0.43474 0.0001	-0.20136 0.0021
TEMP	0.87736 0.0001	1.00000 0.0	0.75901 0.0001	0.54079 0.0001	-0.18424 0.0050
SH	0.66837 0.0001	0.75901 0.0001	1.00000 0.0	-0.01534 0.8167	-0.20623 0.0016
SOL	0.43474 0.0001	0.54079 0.0001	-0.01534 0.8167	1.00000 0.0	-0.12055 0.0674
SALES	-0.20136 0.0021	-0.18424 0.0050	-0.20623 0.0016	-0.12055 0.0674	1.00000 0.0

N = 231

Regression Models for Dependent Variable: HVAC

Number in Model	R-square	Root MSE	Variables in Model
1	0.72833757	282.47775	PRIN1
1	0.04557024	529.47010	PRIN3
1	0.00082806	541.73834	PRIN2
2	0.77390781	258.26321	PRIN1 PRIN3
2	0.72916563	282.66476	PRIN1 PRIN2
2	0.04639829	530.39971	PRIN2 PRIN3
3	0.77473587	258.35703	PRIN1 PRIN2 PRIN3



Model: MODEL1  
Dependent Variable: HVAC

## Analysis of Variance

Source	DF	Sum of Squares	Mean Square	F Value	Prob>F
Model	3	52110837.297	17370279.099	260.235	0.0001
Error	227	15151877.113	66748.357328		
C Total	230	67262714.41			
Root MSE		258.35703	R-square	0.7747	
Dep Mean		1847.70945	Adj R-sq	0.7718	
C.V.		13.98256			

## Parameter Estimates

Variable	DF	Parameter Estimate	Standard Error	T for H0: Parameter=0	Prob >  T
INTERCEP	1	1847.709450	16.99864488	108.697	0.0001
PRIN1	1	332.661110	12.27916320	27.092	0.0001
PRIN2	1	-15.449982	16.91341868	-0.913	0.3620
PRIN3	1	-468.367840	69.11614626	-6.777	0.0001

Model: MODEL1  
Dependent Variable: HVAC

## Analysis of Variance

Source	DF	Sum of Squares	Mean Square	F Value	Prob>F
Model	2	52055140.051	26027570.026	390.219	0.0001
Error	228	15207574.359	66699.887539		
C Total	230	67262714.41			
Root MSE		258.26321	R-square	0.7739	
Dep Mean		1847.70945	Adj R-sq	0.7719	
C.V.		13.97748			

## Parameter Estimates

Variable	DF	Parameter Estimate	Standard Error	T for H0: Parameter=0	Prob >  T
INTERCEP	1	1847.709450	16.99247192	108.737	0.0001
PRIN1	1	332.661110	12.27470409	27.101	0.0001
PRIN3	1	-468.367840	69.09104712	-6.779	0.0001

Model: MODEL1  
Dependent Variable: HVAC

## Analysis of Variance

Source	DF	Sum of Squares	Mean Square	F Value	Prob>F
Model	2	49045659.386	24522829.693	306.921	0.0001
Error	228	18217055.024	79899.364141		
C Total	230	67262714.41			
Root MSE	282.66476	R-square	0.7292		
Dep Mean	1847.70945	Adj R-sq	0.7268		
C.V.	15.29812				

## Parameter Estimates

Variable	DF	Parameter Estimate	Standard Error	T for H0: Parameter=0	Prob >  T
INTERCEP	1	1847.709450	18.59797551	99.350	0.0001
PRIN1	1	332.661110	13.43445776	24.762	0.0001
PRIN2	1	-15.449982	18.50473074	-0.835	0.4046

Model: MODEL1  
Dependent Variable: HVAC

## Analysis of Variance

Source	DF	Sum of Squares	Mean Square	F Value	Prob>F
Model	3	52110837.297	17370279.099	260.235	0.0001
Error	227	15151877.113	66748.357328		
C Total	230	67262714.41			
Root MSE	258.35703	R-square	0.7747		
Dep Mean	1847.70945	Adj R-sq	0.7718		
C.V.	13.98256				

## Parameter Estimates

Variable	DF	Parameter Estimate	Standard Error	T for H0: Parameter=0	Prob >  T
INTERCEP	1	-1814.207733	161.16616517	-11.257	0.0001
TEMP	1	167.784569	14.66203062	11.443	0.0001
SH	1	-19938	11983.805351	-1.664	0.0975
SOL	1	-1.019337	0.45582042	-2.236	0.0263

## Correlation Analysis

5 'WITH' Variables: WHB      TEMP      SH      SOL      SALES  
 5 'VAR' Variables: WHB      TEMP      SH      SOL      SALES

## Simple Statistics

Variable	N	Mean	Std Dev	Sum	Minimum	Maximum
WHB	128	7533	395.3348	964198	6090	9868
TEMP	128	12.6243	4.0348	1616	-0.1748	18.6302
SH	128	0.005918	0.002683	0.7575	0.001313	0.0127
SOL	128	127.0133	82.9947	16258	8.1171	317.5110
SALES	128	47682	9777	6103250	19315	71531

Pearson Correlation Coefficients / Prob > |R| under Ho: Rho=0 / N = 128

	WHB	TEMP	SH	SOL	SALES
WHB	1.00000 0.0	0.70050 0.0001	0.49170 0.0001	0.19650 0.0262	0.09603 0.2809
TEMP	0.70050 0.0001	1.00000 0.0	0.58014 0.0001	0.24403 0.0055	0.06995 0.4327
SH	0.49170 0.0001	0.58014 0.0001	1.00000 0.0	-0.48942 0.0001	0.06136 0.4915
SOL	0.19650 0.0262	0.24403 0.0055	-0.48942 0.0001	1.00000 0.0	-0.06541 0.4632
SALES	0.09603 0.2809	0.06995 0.4327	0.06136 0.4915	-0.06541 0.4632	1.00000 0.0

## Principal Component Analysis

128 Observations  
 3 Variables

## Simple Statistics

	TEMP	SH	SALES
Mean	12.62434743	0.0059179139	47681.64063
Std	4.03484974	0.0026826481	9777.41206

## Correlation Matrix

	TEMP	SH	SALES
TEMP	1.0000	0.5801	0.0699
SH	0.5801	1.0000	0.0614
SALES	0.0699	0.0614	1.0000

## Eigenvalues of the Correlation Matrix

	Eigenvalue	Difference	Proportion	Cumulative
PRIN1	1.59464	0.609069	0.531546	0.53155
PRIN2	0.98557	0.565772	0.328522	0.86007
PRIN3	0.41980	.	0.139932	1.00000

## Eigenvectors

	PRIN1	PRIN2	PRIN3
TEMP	0.699205	-.101588	-.707667
SH	0.698077	-.116589	0.706467
SALES	0.154274	0.987971	0.010603

N = 128      Regression Models for Dependent Variable: WHB

Number in Model	R-square	Root MSE	Variables in Model
1	0.45079099	294.13752	PRIN1
1	0.05170844	386.50271	PRIN3
1	0.00114635	396.67289	PRIN2
-----			
2	0.50249943	281.06622	PRIN1 PRIN3
2	0.45193734	295.00336	PRIN1 PRIN2
2	0.05285480	387.81102	PRIN2 PRIN3
-----			
3	0.50364579	281.87196	PRIN1 PRIN2 PRIN3
-----			

Model: MODEL1  
Dependent Variable: WHB

## Analysis of Variance

Source	DF	Sum of Squares	Mean Square	F Value	Prob>F
Model	3	9996752.542	3332250.8473	41.941	0.0001
Error	124	9852023.7674	79451.804576		
C Total	127	19848776.309			
Root MSE	281.87196	R-square	0.5036		
Dep Mean	7532.79422	Adj R-sq	0.4916		
C.V.	3.74193				

## Parameter Estimates

Variable	DF	Parameter Estimate	Standard Error	T for H0: Parameter=0	Prob >  T
INTERCEP	1	7532.794219	24.91419722	302.349	0.0001
PRIN1	1	210.194680	19.80701909	10.612	0.0001
PRIN2	1	-13.482837	25.19456426	-0.535	0.5935
PRIN3	1	-138.748004	38.60388683	-3.594	0.0005

Model: MODEL1  
 Dependent Variable: WHB

## Analysis of Variance

Source	DF	Sum of Squares	Mean Square	F Value	Prob>F
Model	2	9973998.8118	4986999.4059	63.128	0.0001
Error	125	9874777.4975	78998.21998		
C Total	127	19848776.309			
Root MSE		281.06622	R-square	0.5025	
Dep Mean		7532.79422	Adj R-sq	0.4945	
C.V.		3.73123			

## Parameter Estimates

Variable	DF	Parameter Estimate	Standard Error	T for H0: Parameter=0	Prob >  T
INTERCEP	1	7532.794219	24.84297876	303.216	0.0001
PRIN1	1	210.194680	19.75039975	10.643	0.0001
PRIN3	1	-138.748004	38.49353571	-3.604	0.0005

Model: MODEL1  
 Dependent Variable: WHB

## Analysis of Variance

Source	DF	Sum of Squares	Mean Square	F Value	Prob>F
Model	2	8970403.25	4485201.625	51.538	0.0001
Error	125	10878373.059	87026.984474		
C Total	127	19848776.309			
Root MSE		295.00336	R-square	0.4519	
Dep Mean		7532.79422	Adj R-sq	0.4432	
C.V.		3.91625			

## Parameter Estimates

Variable	DF	Parameter Estimate	Standard Error	T for H0: Parameter=0	Prob >  T
INTERCEP	1	7532.794219	26.07485985	288.891	0.0001
PRIN1	1	210.194680	20.72975670	10.140	0.0001
PRIN2	1	-13.482837	26.36828818	-0.511	0.6100

Model: MODEL1  
 Dependent Variable: WHB

## Analysis of Variance

Source	DF	Sum of Squares	Mean Square	F Value	Prob>F
Model	3	9996752.542	3332250.8473	41.941	0.0001
Error	124	9852023.7674	79451.804576		
C Total	127	19848776.309			
Root MSE	281.87196	R-square	0.5036		
Dep Mean	7532.79422	Adj R-sq	0.4916		
C.V.	3.74193				

## Parameter Estimates

Variable	DF	Parameter Estimate	Standard Error	T for H0: Parameter=0	Prob >  T
INTERCEP	1	6564.526956	143.05985704	45.887	0.0001
TEMP	1	61.099233	7.61746720	8.021	0.0001
SH	1	18744	11450.601221	1.637	0.1042
SALES	1	0.001804	0.00256527	0.703	0.4833

## Correlation Analysis

5 'WITH' Variables:	COMP	TEMP	SH	SOL	SALES
5 'VAR' Variables:	COMP	TEMP	SH	SOL	SALES

## Simple Statistics

Variable	N	Mean	Std Dev	Sum	Minimum	Maximum
COMP	128	2395	208.1008	306602	1821	3201
TEMP	128	12.6243	4.0348	1616	-0.1748	18.6302
SH	128	0.005918	0.002683	0.7575	0.001313	0.0127
SOL	128	127.0133	82.9947	16258	8.1171	317.5110
SALES	128	47682	9777	6103250	19315	71531

Pearson Correlation Coefficients / Prob > |R| under Ho: Rho=0 / N = 128

	COMP	TEMP	SH	SOL	SALES
COMP	1.00000 0.0	0.57785 0.0001	0.34247 0.0001	0.23744 0.0070	0.15980 0.0716
TEMP	0.57785 0.0001	1.00000 0.0	0.58014 0.0001	0.24403 0.0055	0.06995 0.4327
SH	0.34247 0.0001	0.58014 0.0001	1.00000 0.0	-0.48942 0.0001	0.06136 0.4915
SOL	0.23744 0.0070	0.24403 0.0055	-0.48942 0.0001	1.00000 0.0	-0.06541 0.4632
SALES	0.15980 0.0716	0.06995 0.4327	0.06136 0.4915	-0.06541 0.4632	1.00000 0.0

N = 128      Regression Models for Dependent Variable: COMP

Number in Model	R-square	Root MSE	Variables in Model
1	0.27962555	177.32478	PRIN1
1	0.06507598	202.01259	PRIN3
1	0.00356162	208.55254	PRIN2
2	0.34470153	169.80095	PRIN1 PRIN3
2	0.28318717	177.59201	PRIN1 PRIN2
2	0.06863760	202.43234	PRIN2 PRIN3
3	0.34826315	170.02032	PRIN1 PRIN2 PRIN3

Model: MODEL1  
Dependent Variable: COMP

#### Analysis of Variance

Source	DF	Sum of Squares	Mean Square	F Value	Prob>F
Model	3	1915396.1273	638465.37578	22.087	0.0001
Error	124	3584456.8822	28906.91034		
C Total	127	5499853.0096			
Root MSE	170.02032	R-square	0.3483		
Dep Mean	2395.32559	Adj R-sq	0.3325		
C.V.	7.09800				

#### Parameter Estimates

Variable	DF	Parameter Estimate	Standard Error	T for H0: Parameter=0	Prob >  T
INTERCEP	1	2395.325594	15.02781544	159.393	0.0001
PRIN1	1	87.142739	11.94725340	7.294	0.0001
PRIN2	1	12.509908	15.19692802	0.823	0.4120
PRIN3	1	-81.934170	23.28520086	-3.519	0.0006

Model: MODEL1  
Dependent Variable: COMP

#### Analysis of Variance

Source	DF	Sum of Squares	Mean Square	F Value	Prob>F
Model	2	1895807.7573	947903.87865	32.876	0.0001
Error	125	3604045.2523	28832.362018		
C Total	127	5499853.0096			
Root MSE	169.80095	R-square	0.3447		
Dep Mean	2395.32559	Adj R-sq	0.3342		
C.V.	7.08885				

#### Parameter Estimates

Variable	DF	Parameter Estimate	Standard Error	T for H0: Parameter=0	Prob >  T
INTERCEP	1	2395.325594	15.00842524	159.599	0.0001
PRIN1	1	87.142739	11.93183800	7.303	0.0001
PRIN3	1	-81.934170	23.25515626	-3.523	0.0006

Model: MODEL1  
 Dependent Variable: COMP

## Analysis of Variance

Source	DF	Sum of Squares	Mean Square	F Value	Prob>F
Model	2	1557487.7893	778743.89465	24.692	0.0001
Error	125	3942365.2202	31538.921762		
C Total	127	5499853.0096			
Root MSE	177.59201	R-square	0.2832		
Dep Mean	2395.32559	Adj R-sq	0.2717		
C.V.	7.41411				

## Parameter Estimates

Variable	DF	Parameter Estimate	Standard Error	T for H0: Parameter=0	Prob >  T
INTERCEP	1	2395.325594	15.69706426	152.597	0.0001
PRIN1	1	87.142739	12.47931244	6.983	0.0001
PRIN2	1	12.509908	15.87370810	0.788	0.4321

## Correlation Analysis

5 'WITH' Variables:	HVAC	TEMP	SH	SOL	SALES
5 'VAR' Variables:	HVAC	TEMP	SH	SOL	SALES

## Simple Statistics

Variable	N	Mean	Std Dev	Sum	Minimum	Maximum
HVAC	128	784.4384	340.1172	100408	299.3840	2438
TEMP	128	12.6243	4.0348	1616	-0.1748	18.6302
SH	128	0.005918	0.002683	0.7575	0.001313	0.0127
SOL	128	127.0133	82.9947	16258	8.1171	317.5110
SALES	128	47682	9777	6103250	19315	71531

Pearson Correlation Coefficients / Prob > |R| under Ho: Rho=0 / N = 128

	HVAC	TEMP	SH	SOL	SALES
HVAC	1.00000 0.0	0.42151 0.0001	0.33421 0.0001	0.12741 0.1518	-0.03574 0.6888
TEMP	0.42151 0.0001	1.00000 0.0	0.58014 0.0001	0.24403 0.0055	0.06995 0.4327
SH	0.33421 0.0001	0.58014 0.0001	1.00000 0.0	-0.48942 0.0001	0.06136 0.4915
SOL	0.12741 0.1518	0.24403 0.0055	-0.48942 0.0001	1.00000 0.0	-0.06541 0.4632
SALES	-0.03574 0.6888	0.06995 0.4327	0.06136 0.4915	-0.06541 0.4632	1.00000 0.0

N = 128

Regression Models for Dependent Variable: HVAC



Number in Model	R-square	Root MSE	Variables in Model
1	0.17120861	310.86212	PRIN1
1	0.01391242	339.08059	PRIN2
1	0.00932300	339.86874	PRIN3
-----			
2	0.18512104	309.47246	PRIN1 PRIN2
2	0.18053162	310.34271	PRIN1 PRIN3
2	0.02323543	338.82106	PRIN2 PRIN3
-----			
3	0.19444404	308.93526	PRIN1 PRIN2 PRIN3
-----			

Model: MODEL1  
Dependent Variable: HVAC

## Analysis of Variance

Source	DF	Sum of Squares	Mean Square	F Value	Prob>F
Model	3	2856640.266	952213.42199	9.977	0.0001
Error	124	11834683.092	95440.992678		
C Total	127	14691323.358			
Root MSE	308.93526	R-square	0.1944		
Dep Mean	784.43843	Adj R-sq	0.1750		
C.V.	39.38298				

## Parameter Estimates

Variable	DF	Parameter Estimate	Standard Error	T for H0: Parameter=0	Prob >  T
INTERCEP	1	784.438430	27.30627685	28.727	0.0001
PRIN1	1	111.444977	21.70874469	5.134	0.0001
PRIN2	1	-40.409813	27.61356269	-1.463	0.1459
PRIN3	1	-50.685941	42.31035067	-1.198	0.2332

Model: MODEL1  
Dependent Variable: HVAC

## Analysis of Variance

Source	DF	Sum of Squares	Mean Square	F Value	Prob>F
Model	2	2652248.3328	1326124.1664	13.769	0.0001
Error	125	12039075.025	96312.600202		
C Total	127	14691323.358			
Root MSE	310.34271	R-square	0.1805		
Dep Mean	784.43843	Adj R-sq	0.1674		
C.V.	39.56241				

## Parameter Estimates

Variable	DF	Parameter Estimate	Standard Error	T for H0: Parameter=0	Prob >  T
INTERCEP	1	784.438430	27.43067970	28.597	0.0001
PRIN1	1	111.444977	21.80764612	5.110	0.0001
PRIN3	1	-50.685941	42.50310959	-1.193	0.2353

Model: MODEL1  
 Dependent Variable: HVAC

Analysis of Variance

Source	DF	Sum of Squares	Mean Square	F Value	Prob>F
Model	2	2719673.0211	1359836.5105	14.199	0.0001
Error	125	11971650.337	95773.202696		
C Total	127	14691323.358			
Root MSE	309.47246	R-square	0.1851		
Dep Mean	784.43843	Adj R-sq	0.1721		
C.V.	39.45147				

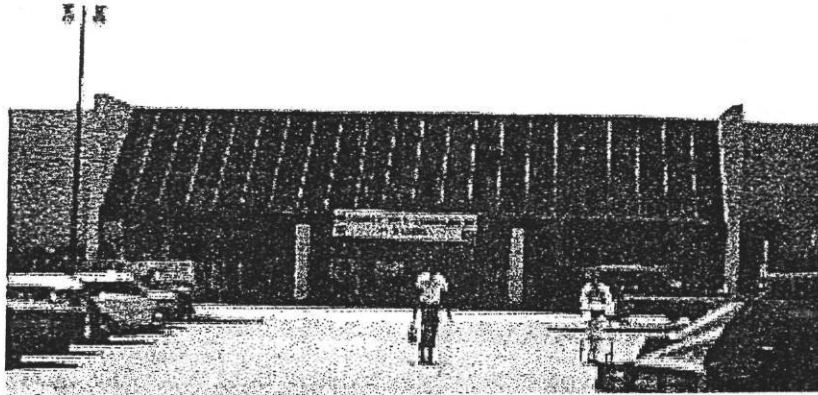
Parameter Estimates

Variable	DF	Parameter Estimate	Standard Error	T for H0: Parameter=0	Prob >  T
INTERCEP	1	784.438430	27.35375927	28.678	0.0001
PRIN1	1	111.444977	21.74649366	5.125	0.0001
PRIN2	1	-40.409813	27.66157944	-1.461	0.1466

## APPENDIX F

### SITE PHOTOGRAPHS

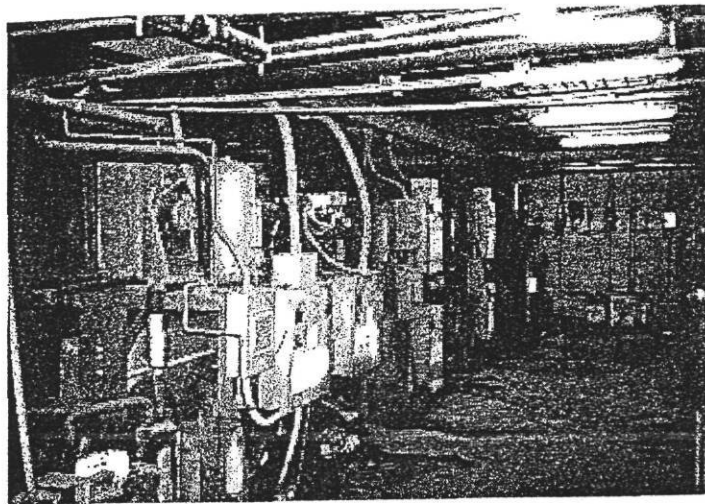
This appendix contains photographs from the College Station and Bryan case study stores.



*Figure F.1* Front of the College Station store. The front of the main store, including the covered porch and glass section is shown here. The parking lot lights directly in front of the store are connected to its lighting circuit.

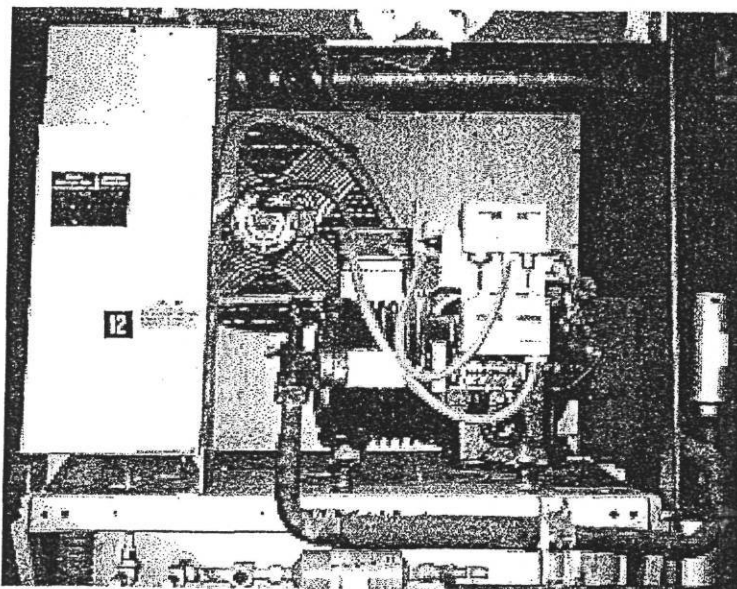


*Figure F.2* Front of the Bryan store. The front of the main store, including the covered porch and glass section is shown here.



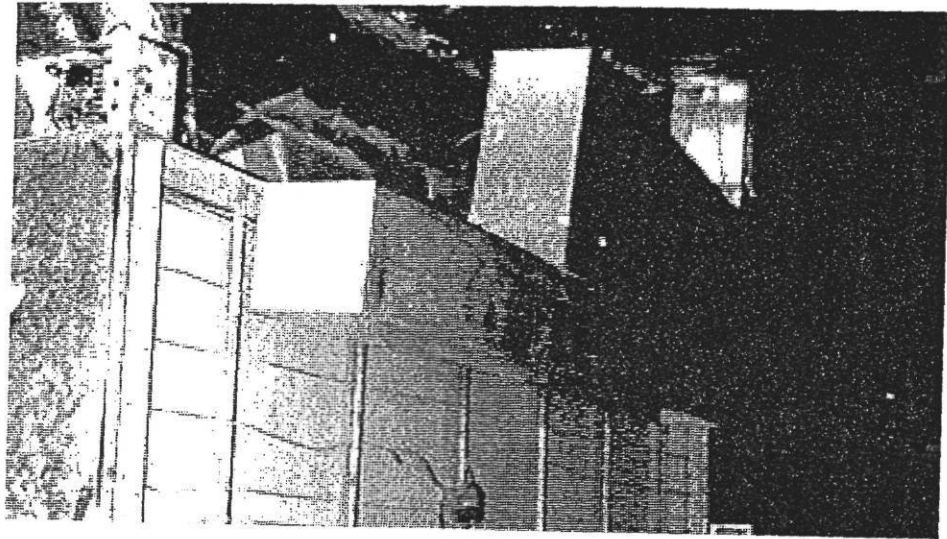
*Figure F.3*

*Refrigeration compressor room at College Station store. The compressor room at this store is almost identical to that at the Bryan store. Each compressor is dedicated to a single group of refrigerated display cases and merchandisers.*



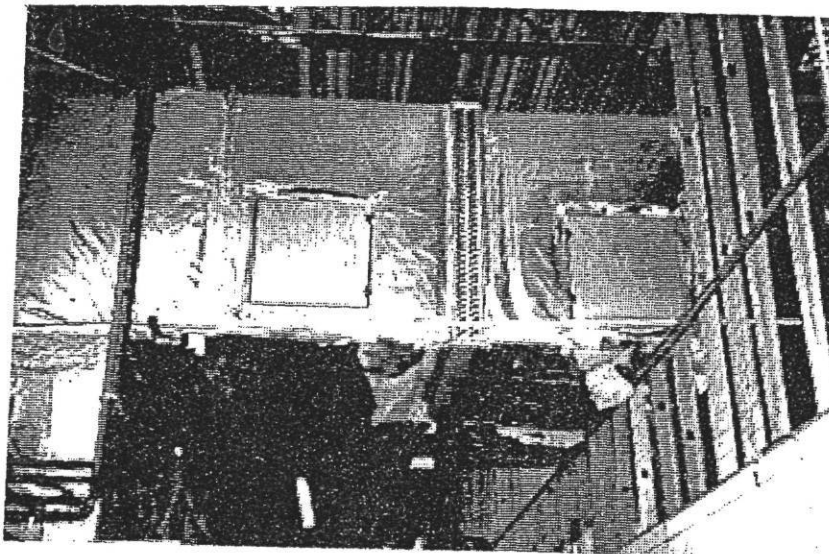
*Figure F.4*

*Refrigeration compressor #12 at the College Station store. This compressor uses the refrigerant, R12, and serves the island produce displays. This compressor is typical of all compressors used for refrigeration at both stores.*



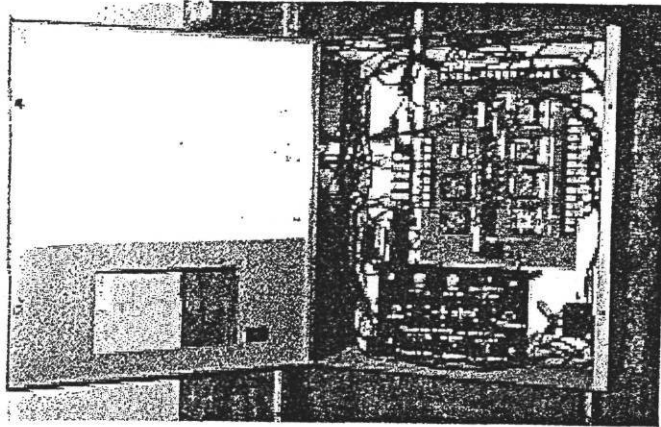
*Figure F.5*

*Return air grille on air-handler unit #1 at the College Station store. The duct at the top of the grille allows outdoor air to be pulled in.*

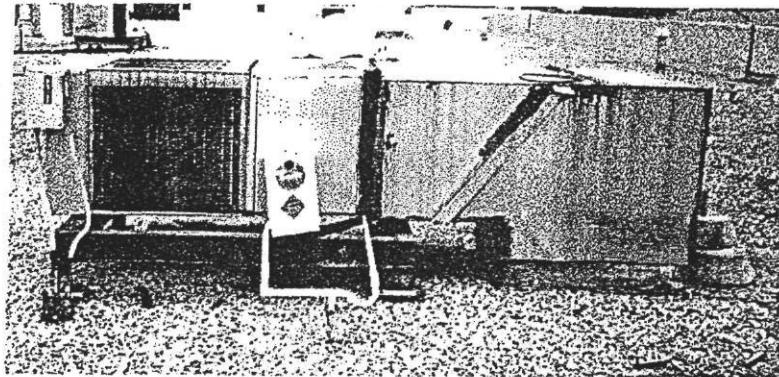


*Figure F.6*

*Air-handler supply duct at the College Station store. Between the two access doors can be seen the reclaim heat coils. The coils transfer waste heat from the refrigeration system to the supply air. This provides adequate space heating for 99% of the time. There are auxiliary gas-fired duct heaters (not shown here) installed about 25 feet downstream.*

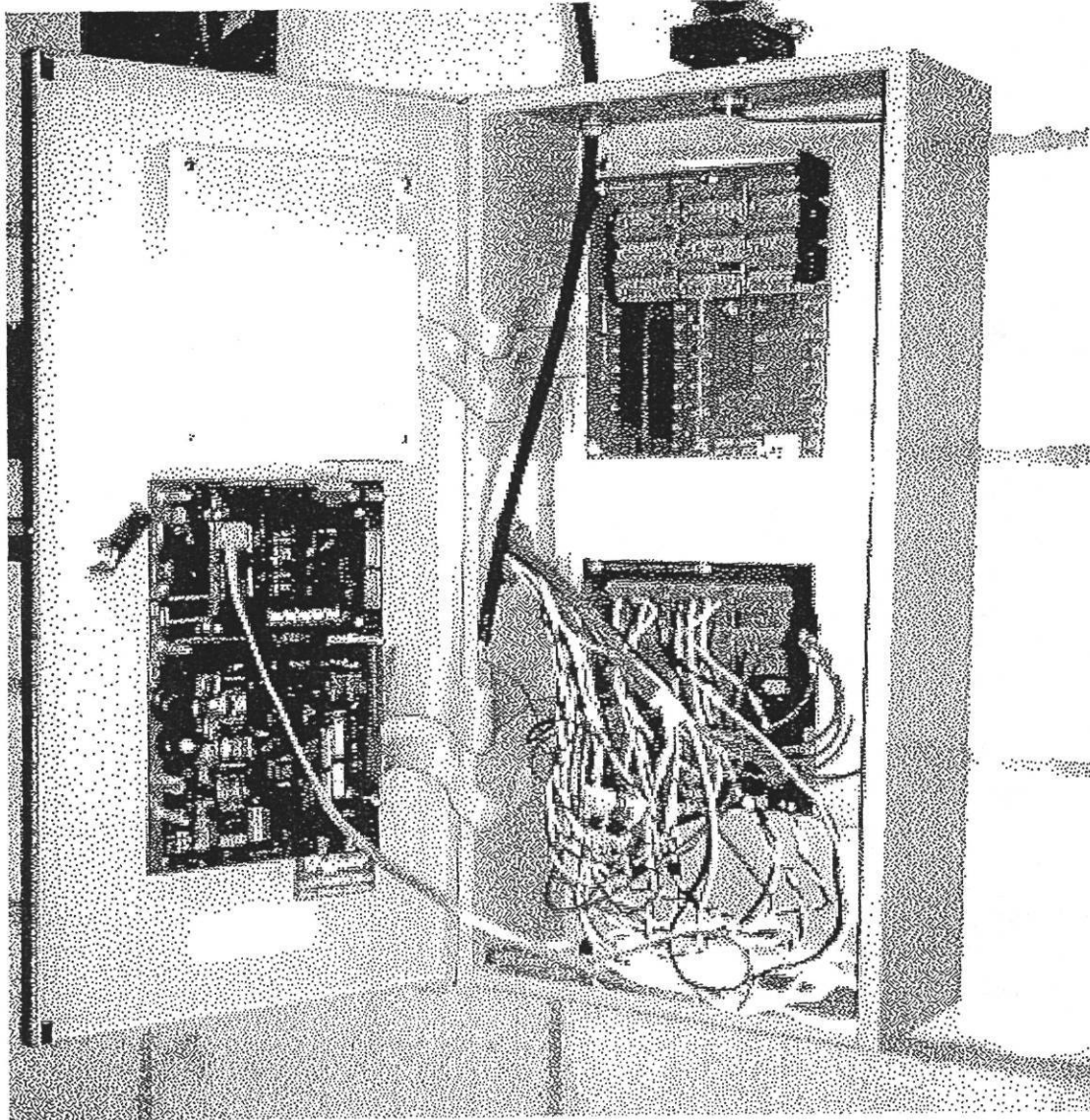


*Figure F.7* HVAC control circuit box for air-handler unit #1 at College Station store.



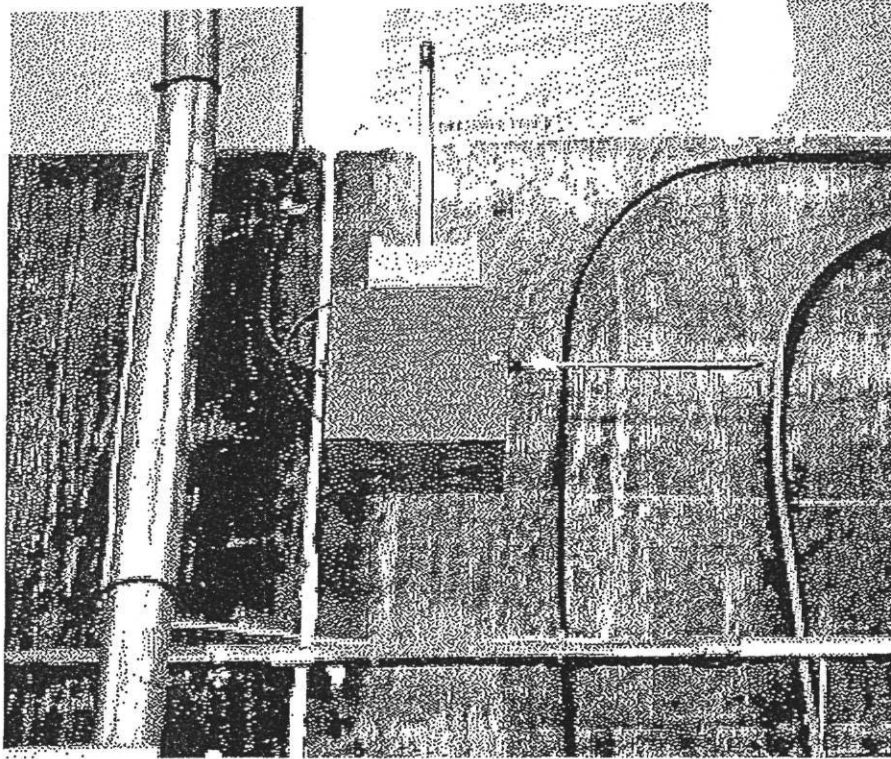
*Figure F.8* Roof-top HVAC unit at the Bryan store. There are twelve working roof-top units at the Bryan store. All but one use natural gas for heating.





*Figure F.9*

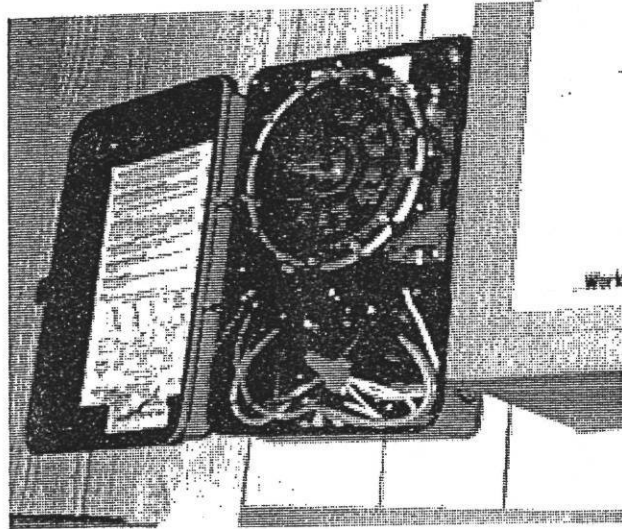
*Data acquisition equipment at the Bryan store. This data logger is identical to the one at the College Station store. The black and white wires are connected to current transducers which monitor the electrical power being used by the four main component loads of the store. Readings are accumulated and recorded on an hourly basis. Data are retrieved via a modem (seen at the bottom of the box) and stored on a computer disk.*



*Figure F.10*

*Temperature and relative humidity sensor for return air conditions at College Station store. The signals from these sensors are recorded as part of the sub-metered, hourly data stream.*





**Figure F.11**

*Time clock control for the parking lot lights at the College Station store. The cut-on and cut-off times are changed by adding or removing small screws to the edge of the rotating disk (visible in this picture). The management changes the timer settings each month to adjust for changes the time of dawn and dusk. Since the parking lot lights are the only lights in the store with varying schedules, the store's daily lighting load follows a sinusoidal pattern throughout the year.*

## APPENDIX G

### PHYSICAL SIGNIFICANCE OF MODEL PARAMETERS: DIVERSIFIED LOAD CALCULATIONS

This appendix contains the detailed calculations used in Chapter 4 to evaluate the relative merits of the MLR and PCA models of whole-building and HVAC system energy use. The MLR and PCA models give parameters which predict the variation of energy use due to climate variables for the College Station store. To determine if these parameters have any physical significance, and to determine which model gives more realistic estimates, the climate-variant portions of the building's energy use can be modeled by a diversified load calculation method. In using this method we adopt the procedure outlined by Knebel (1983).

#### G.1 VARIATION DUE TO SOLAR LOAD

The diversified load calculation method accounts for solar gains as well as ambient temperature gains. We use only the portion of this procedure which account for solar loads. The calculation of the loads is divided into three sections which consider the cooling load on the walls, on the roof, and through the glazing of the store. For a description of building characteristics, see Chapter 2, Section 2.1.

**Wall Load.** The transmission load on the roof due to solar effects is given by,

$$q_{ts} = M \cdot (T - T_{ph}) + q_{ts,Jan}$$

where,

$$T = \text{outdoor ambient air temperature}$$

$$M = (q_{ts,Jul} - q_{ts,Jan}) / (T_{pc} - T_{ph})$$

$$\begin{aligned} q_{ts,Jan} &= \text{solar transmission contribution for January} \\ &= U \cdot A_s \times CLTDS_{Jan} \cdot K \cdot FPS_{Jan} / A_f \end{aligned}$$

$$\begin{aligned} q_{ts,Jul} &= \text{solar transmission contribution for July} \\ &= U \cdot A_s \cdot CLTDS_{Jul} \cdot K \cdot FPS_{Jul} / A_f \end{aligned}$$

$CLTDS_{Jan}$  = 24 hour averaged solar component of cooling load temperature difference for January.

$CLTDS_{Jul}$  = 24 hour averaged solar component of cooling load temperature difference for July.

$K$  = color correction factor for a given surface.

$U$  = heat transfer coefficient of exposed surface.

$A_s$  = exposed surface area

$A_f$  = floor area. This term is used only if a cooling load per unit area

is

desired.

$FPS_{Jan}$  = fraction of possible sunshine for January

$FPS_{Jul}$  = fraction of possible sunshine for July

$T_{ph}$  = design temperature for heating season

$T_{pc}$  = design temperature for cooling season

For the walls,

$U$  = 0.119 Btu/hr·ft<sup>2</sup>·°F (0.675 W/m<sup>2</sup>·°C)

$K$  = 0.83

The wall areas are,

$A_{SW}$  = 5,000 ft<sup>2</sup> (465 m<sup>2</sup>)

$A_{NE}$  = 4,040 ft<sup>2</sup> (375 m<sup>2</sup>)

$CLTDS_{Jan,NE}$  = 2 °F (1.1 °C)

$CLTDS_{Jan,SW}$  = 16 °F (8.9 °C)

$CLTDS_{Jul,NE}$  = 11 °F (6.1 °C)

$CLTDS_{Jul,SW}$  = 13 °F (7.2 °C)

For College Station, sunshine conditions were assumed to be the same as those for Austin. The fractions of possible sunshine for winter and summer are,

$FPS_{Jan}$  = 0.46

$FPS_{Jul}$  = 0.76

The hourly temperature extremes observed at the case study store were about  $-2.5^{\circ}\text{C}$  and  $37.5^{\circ}\text{C}$  ( $36^{\circ}\text{F}$  and  $99^{\circ}\text{F}$ ).

$$\begin{aligned} T_{\text{ph}} &= -2.5^{\circ}\text{C} \\ T_{\text{pc}} &= 37.5^{\circ}\text{C} \end{aligned}$$

We are not interested in the solar load per unit of floor area. Therefore, neglecting the floor area term,

$$\begin{aligned} q_{\text{ts,Jan}} &= (U_{\text{wall}} \cdot A_s \cdot \text{CLTDS}_{\text{Jan}} \cdot K \cdot \text{FPS}_{\text{Jan}})_{\text{SW}} \\ &\quad + (U_{\text{wall}} \cdot A_s \cdot \text{CLTDS}_{\text{Jan}} \cdot K \cdot \text{FPS}_{\text{Jan}})_{\text{NE}} \\ &= (0.675 \text{ W/m}^2 \cdot ^{\circ}\text{C})(465 \text{ m}^2)(8.9^{\circ}\text{C})(0.83)(0.46) \\ &\quad + (0.675 \text{ W/m}^2 \cdot ^{\circ}\text{C})(375 \text{ m}^2)(1.1^{\circ}\text{C})(0.83)(0.46) \\ &= 1.173 \text{ kW}_{\text{th}} \end{aligned}$$

Again omitting the floor area term, the solar transmission effects during July are,

$$\begin{aligned} q_{\text{ts,Jul}} &= U A_s \cdot \text{CLTDS}_{\text{Jul}} \cdot K \cdot \text{FPS}_{\text{Jul}} \\ &= (0.675 \text{ W/m}^2 \cdot ^{\circ}\text{C})(465 \text{ m}^2)(7.2^{\circ}\text{C})(0.83)(0.46) \\ &\quad + (0.675 \text{ W/m}^2 \cdot ^{\circ}\text{C})(375 \text{ m}^2)(6.1^{\circ}\text{C})(0.83)(0.46) \\ &= 2.4 \text{ kW} \end{aligned}$$

With the two end-points established, the interpolation slope is,

$$\begin{aligned} M &= (q_{\text{ts,Jul}} - q_{\text{ts,Jan}})/(T_{\text{pc}} - T_{\text{ph}}) \\ &= (2.4 \text{ kW} - 1.173 \text{ kW})/(37.5^{\circ}\text{C} + 2.5^{\circ}\text{C}) \\ &= 0.0307 \text{ kW/}^{\circ}\text{C} \end{aligned}$$

So, the cooling load for the walls is,

$$\begin{aligned} q_{\text{ts}} &= M (T - T_{\text{ph}}) + q_{\text{ts,Jan}} \\ &= (0.0307 \text{ kW/}^{\circ}\text{C})(T + 2.5^{\circ}\text{C}) + 1.173 \text{ kW} \end{aligned}$$

This gives an estimation of the solar load based on ambient temperature. We are only interested in the *variation* in the solar load, since the solar coefficients of the MLR and PCA models only predict variations in solar effects. The variation in solar load contribution is simply the difference between  $q_{ts,Jul}$  and  $q_{ts,Jan}$ .

$$\begin{aligned} &= 2.4 - 1.173 \\ &= 1.23 \text{ kW}_{th} \end{aligned}$$

where the subscript "th" is used to designate thermal energy.

**Roof Loads.** The procedure for calculating the roof load is the same as it is for the wall loads.

For the roof,

$$\begin{aligned} U_{roof} &= 0.131 \text{ Btu/hr}\cdot\text{ft}^2\cdot\text{°F} \\ &= 0.744 \text{ W/m}^2\cdot\text{°C} \\ K &= 0.75 \end{aligned}$$

The roof area is,

$$A_{roof} = 46,000 \text{ ft}^2 (4,275 \text{ m}^2)$$

For a location at 32° latitude,

$$\begin{aligned} \text{CLTDS}_{Jan,roof} &= 7 \text{ °F} (3.9 \text{ °C}) \\ \text{CLTDS}_{Jul,roof} &= 23 \text{ °F} (12.8 \text{ °C}) \end{aligned}$$

For College Station, sunshine conditions were assumed to be the same as those for Austin.

$$\begin{aligned} \text{FPS}_{Jan} &= 0.46 \\ \text{FPS}_{Jul} &= 0.76 \end{aligned}$$

The hourly temperature extremes observed at the case study store were about -2.5°C and 37.5°C (36°F and 99°F).

$$\begin{aligned} T_{ph} &= -2.5\text{°C} \\ T_{pc} &= 37.5\text{°C} \end{aligned}$$

Neglecting the floor area term,

$$\begin{aligned}
 q_{ts,Jan} &= U A_s \cdot CLTDS_{Jan} \cdot K \cdot FPS_{Jan} / A_f \\
 &= (0.744 \text{ W/m}^2 \cdot \text{°C})(4,275 \text{ m}^2)(3.9 \text{ °C})(0.75)(0.46) \\
 &= 4.28 \text{ kW}
 \end{aligned}$$

$$\begin{aligned}
 q_{ts,Jul} &= U A_s \cdot CLTDS_{Jul} \cdot K \cdot FPS_{Jul} / A_f \\
 &= (0.744 \text{ W/m}^2 \cdot \text{°C})(4,275 \text{ m}^2)(12.8 \text{ °C})(0.75)(0.76) \\
 &= 23.2 \text{ kW}_{th}
 \end{aligned}$$

$$\begin{aligned}
 M &= (q_{ts,Jul} - q_{ts,Jan}) / (T_{pc} - T_{ph}) \\
 &= (23.2 \text{ kW} - 4.28 \text{ kW}) / (37.5 \text{ °C} + 2.5 \text{ °C}) \\
 &= 0.473 \text{ kW/°C}
 \end{aligned}$$

So, the cooling load for the walls is,

$$\begin{aligned}
 q_{ts} &= M (T - T_{ph}) + q_{ts,Jan} \\
 &= (0.0307 \text{ kW/°C})(T + 2.5 \text{ °C}) + 1.173 \text{ kW}
 \end{aligned}$$

The variation in solar load is simply the difference in  $q_{ts,Jul}$  and  $q_{ts,Jan}$ .

$$\begin{aligned}
 &= 23.2 - 4.25 \\
 &= 19.0 \text{ kW}_{th}
 \end{aligned}$$

**Glazing.** The transmission load through windows due to solar effects is given by,

$$q_{sol} = M (T - T_{ph}) + q_{sol,Jan}$$

where,

$$\begin{aligned}
 T &= \text{outdoor ambient air temperature} \\
 M &= \text{interpolation slope} \\
 &= (q_{sol,Jul} - q_{sol,Jan}) / (T_{pc} - T_{ph})
 \end{aligned}$$

$$q_{\text{sol,Jan}} = \text{averaged solar transmission contribution for January}$$

$$= \text{MSHGF}_{\text{Jan}} \cdot A_g \cdot \text{SC} \cdot \text{CLFTOT} \cdot \text{FPS}_{\text{Jan}} / (t \cdot A_f)$$

$$q_{\text{sol,Jul}} = \text{averaged solar transmission contribution for July}$$

$$= \text{MSHGF}_{\text{Jan}} \cdot A_g \cdot \text{SC} \cdot \text{CLFTOT} \cdot \text{FPS}_{\text{Jan}} / (t \cdot A_f)$$

$\text{MSHGF}_{\text{month}}$  = maximum solar heat gain factor for orientation of wall for a given month at the specified latitude.

$A_g$  = exposed glass area

$\text{SC}$  = shading coefficient for glass exposure

$\text{CLFTOT}$  = 24-hour sum of CLF values for a particular orientation of glass exposure

$\text{FPS}_{\text{Jan}}$  = fraction of possible sunshine for January

$\text{FPS}_{\text{Jul}}$  = fraction of possible sunshine for July

$T_{\text{ph}}$  = design temperature for heating season

$T_{\text{pc}}$  = design temperature for cooling season

For the windows,

$$\text{SC} = 0.70$$

$\text{CLFTOT} = 5.15$  for a NE glass exposure.

$$\text{MSHGF}_{\text{Jan,NE}} = 65 \text{ Btu/hr/ft}^2 \text{ (205 W/m}^2\text{)}$$

$$\text{MSHGF}_{\text{Jul,NE}} = 167 \text{ Btu/hr/ft}^2 \text{ (527 W/m}^2\text{)}$$

The window area is,

$$A_g = 960 \text{ ft}^2 \text{ (89 m}^2\text{)}$$

The air-handlers run 24 hours per day.

$$t = 24$$

For College Station, sunshine conditions were assumed to be the same as those for Austin.

$$\text{FPS}_{\text{Jan}} = 0.46$$

$$\text{FPS}_{\text{Jul}} = 0.76$$

The hourly temperature extremes observed at the case study store were about  $-2.5^{\circ}\text{C}$  and  $37.5^{\circ}\text{C}$  ( $36^{\circ}\text{F}$  and  $99^{\circ}\text{F}$ ).

$$T_{\text{ph}} = -2.5^{\circ}\text{C}$$

$$T_{\text{pc}} = 37.5^{\circ}\text{C}$$

Neglecting the floor area term,

$$\begin{aligned} q_{\text{sol,Jan}} &= \text{MSHGF}_{\text{Jan}} A_g \cdot \text{SC} \cdot \text{CLFTOT} \cdot \text{FPS}_{\text{Jan}} / t \\ &= (205 \text{ W/m}^2)(89 \text{ m}^2)(0.70)(5.15)(0.46)/(24) \\ &= 2.74 \text{ kW} \end{aligned}$$

$$\begin{aligned} q_{\text{sol,Jul}} &= \text{MSHGF}_{\text{Jan}} A_g \cdot \text{SC} \cdot \text{CLFTOT} \cdot \text{FPS}_{\text{Jan}} / (t \cdot A_f) \\ &= (527 \text{ W/m}^2)(89 \text{ m}^2)(0.70)(5.15)(0.76)/(24) \\ &= 11.6 \text{ kW} \end{aligned}$$

$$\begin{aligned} M &= (q_{\text{sol,Jul}} - q_{\text{sol,Jan}})/(T_{\text{pc}} - T_{\text{ph}}) \\ &= (11.6 \text{ kW} - 2.74 \text{ kW})/(37.5^{\circ}\text{C} + 2.5^{\circ}\text{C}) \\ &= 0.222 \text{ kW}/^{\circ}\text{C} \end{aligned}$$

So, the cooling load for the walls is,

$$\begin{aligned} q_{\text{sol}} &= M (T - T_{\text{ph}}) + q_{\text{sol,Jan}} \\ &= (0.222 \text{ kW}/^{\circ}\text{C})(T + 2.5^{\circ}\text{C}) + 2.74 \text{ kW} \end{aligned}$$

The variation in solar load contribution is simply the difference in  $q_{\text{ts,Jul}}$  and  $q_{\text{ts,Jan}}$ .

$$\begin{aligned} &= 11.6 \text{ kW} - 2.74 \text{ kW} \\ &= 8.84 \text{ kW}_{\text{th}} \end{aligned}$$

So, the total possible variation in cooling load due to solar effects is,

$$\begin{aligned} \text{Load } q_{\text{sol,total}} &= \text{Roof Transmission Load} + \text{Wall Transmission Load} + \text{Glazing} \\ &= 19.0 \text{ kW}_{\text{th}} + 1.23 \text{ kW}_{\text{th}} + 8.84 \text{ kW}_{\text{th}} \\ &= 29.1 \text{ kW} \end{aligned}$$



The calculations give a total possible variation in cooling load due to solar effects of  $29.1 \text{ kW}_{\text{th}}$ .<sup>1</sup> A seasonal energy efficiency ratio (SEER) of the HVAC system was not available, but its general energy efficiency ratio (EER) was found to be  $7.1 \text{ Btu/W}_e \cdot \text{h}$ . This amounts to a coefficient of performance (COP) of  $2.08 \text{ kW}_{\text{th}}/\text{kW}_e$ . What this means is that it takes only  $1 \text{ kW}$  of electrical power to cool a thermal load of  $2.08 \text{ kW}$ . This means that the portion of the load due to solar radiation is only  $29.1/2.08$ , or  $14.0 \text{ kW}_e$ .

The 1992 MLR model analysis predicts that there is no significant variation in load due to solar radiation or specific humidity. In fact, the values it gives are *near-zero*, and often negative! However, the 1992 PCA model predicts that the average variable component of the electricity load due to solar effects is  $19.6 \text{ kW}_e$ . The 1989 MLR and PCA models predict average values of  $12.5$  and  $21.6 \text{ kW}_e$ , respectively. This seems comparable to the  $14.0 \text{ kW}_e$  variation estimated by CLTDS techniques.

MLR and PCA models were developed for the HVAC load. Tables 4.17 and 4.18, in Chapter 4, show the regression summaries. The models predict an average load due to solar effects of  $-9.1 \text{ kW}_e$  for MLR, and  $15.5 \text{ kW}_e$  for PCA. The fact that the HVAC MLR model predicts a negative load suggests that it is wholly inappropriate for estimating solar effects when other variables are also used in the regression. The fact that the HVAC PCA model predicts  $15.5 \text{ kW}_e$ , allows us to make two points. First, PCA does better at predicting the solar load since the PCA prediction is almost exactly equal to the CLTDS prediction,  $14.0 \text{ kW}$ . Second, since the PCA prediction is quite close to the  $19.6 \text{ kW}_e$  predicted by the *whole-building* data, we conclude that the solar load on the whole building appears primarily in the HVAC load.

In both 1989 and 1992 models, it can be seen that MLR techniques underestimate the effects of solar radiation, though this most apparent from the 1992 models. Thus, for this case study, PCA is of benefit in estimating the effects of predictor variables when these variables are correlated.

---

<sup>1</sup> The subscript "th" is used to designate thermal energy. Likewise, a subscript of "e" will be used to refer to electrical energy.

## G.2 VARIATION DUE TO TEMPERATURE

The variation in building electricity load due to temperature can be divided into two components -- that pertaining to the HVAC system, and that pertaining to the refrigeration system. Since the HVAC system keeps the interior space conditions fairly constant, the effect of outdoor air temperature on the refrigeration system is realized via the refrigeration system's condenser coils, which are exposed to outdoor ambient air.

The coefficients of temperature in the PCA and MLR models reflect the whole building's response to temperature, and thus reflect the combined effect of outdoor temperature on both the HVAC system and the refrigeration system.

A simple energy balance equation, with respect to the temperature difference across the store's walls and roof should be useful in determining the effects of outside temperature on the HVAC system. We again adopt the procedure outlined by Knebel.

$$q_t = \Sigma U A (T_o - T_i)$$

where,

U = U-value of the wall, roof, or glazing

A = surface area of wall, roof, or glazing

T<sub>o</sub> = outdoor ambient temperature

T<sub>i</sub> = indoor temperature

The U A term represents the temperature coefficient which should be predicted by the PCA and MLR models, if the parameters in those models are physically meaningful.

We are interested, then, in the sum of the U A terms for the store.

**Roof.** From the previous calculations for the solar load, we know that,

$$U_{\text{roof}} = 0.131 \text{ Btu/hr}\cdot\text{ft}^2\cdot^\circ\text{F}$$

$$= 0.744 \text{ W/m}^2\cdot^\circ\text{C}$$

$$A_{\text{roof}} = 46,000 \text{ ft}^2 (4,275 \text{ m}^2)$$

$$(UA)_{\text{roof}} = 3.181 \text{ kW}/^\circ\text{C}$$

**Walls.**

$$U_{\text{wall}} = 0.119 \text{ Btu/hr}\cdot\text{ft}^2\cdot^\circ\text{F} \text{ (0.675 W/m}^2\cdot^\circ\text{C)}$$

$$A_{\text{SW}} = 5,000 \text{ ft}^2 \text{ (465 m}^2\text{)}$$

$$A_{\text{NE}} = 4,040 \text{ ft}^2 \text{ (375 m}^2\text{)}$$

$$(U A)_{\text{wall,SW}} = 0.314 \text{ kW}/^\circ\text{C}$$

$$(U A)_{\text{wall,NE}} = 0.253 \text{ kW}/^\circ\text{C}$$

### Glazing.

The window area is,

$$A_{\text{g}} = 960 \text{ ft}^2 \text{ (89 m}^2\text{)}$$

$$U_{\text{g}} = 1.11 \text{ Btu/hr}\cdot\text{ft}^2\cdot^\circ\text{F}$$

$$= 6.30 \text{ W/m}^2\cdot^\circ\text{C}$$

$$(U A)_{\text{g}} = 0.561 \text{ kW}/^\circ\text{C}$$

Thus, the sum of the U A values is  $(3.181 + 0.314 + 0.253 + 0.561)$ , or  $4.308 \text{ kW}_{\text{th}}/^\circ\text{C}$ .

This should represent the variation in the HVAC load due to temperature (and temperature only). Accounting for the COP of the HVAC system, which is 2.08  $\text{kW}_{\text{th}}/\text{kW}_{\text{e}}$ , the temperature coefficient is  $2.07 \text{ kW}_{\text{e}}/^\circ\text{C}$ .