

Initial Commissioning of a Water to Water GHP system in KIER

Jiyoung Kim
Researcher
Korea Institute of Energy Research.
Daejeon, & Korea

Ki Chang Chang
Principal Researcher
Korea Institute of Energy Research.
Daejeon, & Korea

Jea Chul Jang
Researcher
Korea Institute of Energy Research.
Daejeon, & Korea

Euy Joon Lee
Principal Researcher
Korea Institute of Energy Research.
Daejeon, & Korea

Eun Chul Kang
Researcher
Korea Institute of Energy Research.
Daejeon, & Korea

Yongchan Kim
Professor
Department of Mechanical
Engineering, Korea University.
Seoul, & Korea

ABSTRACT – GHP(Geothermal Heat Pump) system has been extensively disseminated due to the recent increasing demand of the new and renewable energy in Korea. However, the system reliability issues have been key barriers to ensure system performance as initially designed. This paper introduces a systematic method to verify its actually operating performance of a water to water GHP system. The main idea is to compare the actual performance with the manufacture data and then to reduce the gap between the actual and the manufacture data. The key result of this study is the development of a simplified GHP performance verification technique using the ISO standard based manufacture data. The manufacture performance data includes the information of EWT(entering water temperature), LWT(leaving water temperature), capacity, flow rate, power and COP. This technique has been verified to a w to w GHP system designed and installed at KIER site. The verification study showed that actual performance was lower than Manufacture data. And then the refrigerant was recharged and the compressor and the expansion valve were replaced. As a result, we can easily identify the GHP system problems and heating and cooling COP has been increased 25.26%, 18.24%.

Key Words – GHP, Manufacture Performance data, Performance verification, COP, ISO 13256- 2.

INTRODUCTION

One of critical solutions to reduce global GHG warming problem is to be GHP(Geothermal heat pump) effectively. GHP system is the most energy efficient, environmentally clean and cost-effective space-conditioning system and produces the lowest carbon dioxide emissions of all available space-conditioning technologies.

In Korea, government provides many subsidy and feed in-tariff it system to disseminate the energy systems including GHP in the new government building. One of government policy is that new federal public building should include new and renewable energy system more than 5% of total initial building construction cost. GHP system could be one of the effective new and renewable energy system mostly considered far this federal

building construction project. However, the reliably issue of GHP system has been critical problem to be solver in the real projects.

In fact, GHP system performance is affected by installation condition, depending on the surrounding environment changes constantly. One critical issue from the previous unit performance approves not whole GHP system installation effects. Currently, GHP unit performance is certified test standards ISO 12356-1, 2. This method cannot verify whole GHP system performance.

This paper introduces a new technique to improve the actual GHP system performance and the system reliability as well. The new technique is defined or the process to improve the actual installs conditions according to the intended designed conditions. This process could improve the system performance of a GHP system as originally designed as performance data. The purpose of this paper is to introduce a new GHP system performance verification technique not just for a unit performance but a whole system performance. The new verification technique is final goal of identify and solve existing operating system problems, minimize energy consumption and Minimize total operating cost. The proposed performance verification method is to be demonstrated with water to water GHP system designed and installed at KIER site. The new performance verification method will be verified and justified with this example study.

Water to water GHP Performance Verification method

ISO 13256-2 test method

International standard method to test a water to water GHP unit is so far based on ISO 13256-2. According to the pre-promised test conditions of water to water, brine to water, GHP unit, Table 1 summarizes the key test conditions for a typical water to water GHP unit thermal performance. They include inside water temperature in load side while ambient temperature and exchanging liquid temperature at standard and part load condition in source side. The unit should be operated at least more than one hour for steady state conditions before testing.

The data acceptance criteria the maximum allowable error is $\pm 1.0^{\circ}\text{C}$ for indoor water temperature and $\pm 0.5^{\circ}\text{C}$ for entering water temperature. The data needs to be recorded every 5 minutes for at least 30 minutes. The data should be averaged for a later ISO data production. The GHP supplier should provide this type ISO data and later be verified at the accredited institute. As previously mentioned, the previous unit performance approves not address the whole system performance. The system effects may include all passive conditions not matching to the ISO test conditions.

Table 1: ISO 13256-2 Test conditions of water source heat pump.

	WLHP	GWHP	GLHP
Cooling			
Liquid Entering Indoor Side [$^{\circ}\text{C}$]	12	12	12
Standard Rating Test			
Liquid Entering Heat Exchanger [$^{\circ}\text{C}$]	30	15	25
Part-load Rating Test			
Liquid Entering Heat Exchanger	30	15	25
Fluid Flow Rate	*	*	*
Heating			
Liquid Entering Indoor Side [$^{\circ}\text{C}$]	40	40	40
Standard Rating Test			
Liquid Entering Outdoor-side Heat Exchanger [$^{\circ}\text{C}$]	20	15	0
Part-load Rating Test			
Liquid Entering Outdoor-side Heat Exchanger	20	10	5
Fluid Flow Rate	*	*	*

* Flow rate is specified by the manufacturer

WLHP = Water Loop Heat Pump
 GWHP = Ground Water Heat Pump
 GLHP = Ground Loop Heat Pump

Performance data based verification method

Figure 1 shows this performance data based GHP system verification process concept. Manufacturer’s published performance chart includes the information of entering water temperature, leaving water temperature, capacity, flow rate, power and COP. This method is based on EWT, LWT and then compares the temperature, capacity, refrigerant, electric input power and COP. If GHP system is ideal states, gap is zero

between actual performance factor and performance data published by manufacture. But GHP system installed site is not ideal. Therefore key idea is to compare the actual performance data with the performance data and then to reduce the gap between the actual and the performance data.

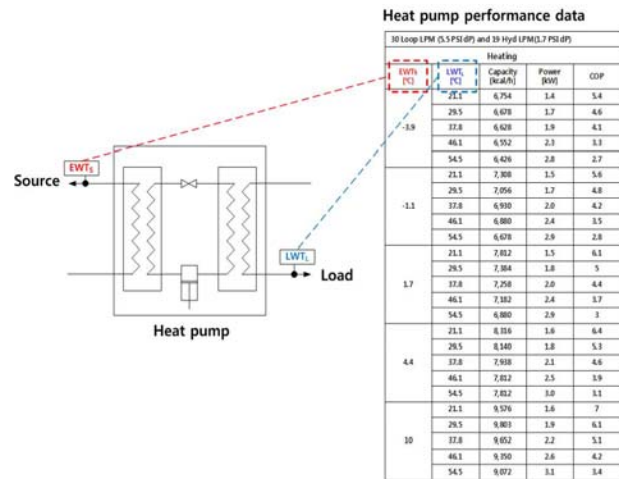

Figure 1. GHP system performance verification concept.

Performance data based Verification technique at KIER

Experimental set-up

The Water to Water GHP system is acted to demonstrate performance data based Verification technical. Figure 2 shows test GHP system configuration in KIER. The system refrigerant is R22 and capacity is a 10kw-class. Heat pump on/off is controlled storage tank temperature. And system is coupled 200m vertical type ground heat exchanger. The system was installed five years ago and was not repaired at all.

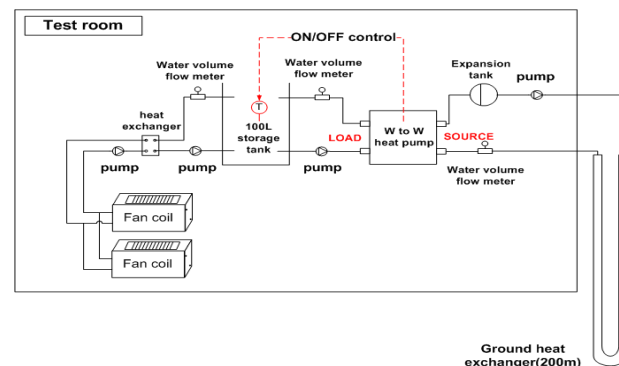

Figure 2. A 10kW class-KIER test cell.

Figure 3 shows schematic of field test setup for the performance verification of a w to w heat pump. Measurement device is a RTD temperature sensor, power meter, water flow meter and pressure sensor. Out signal of each equipment and sensor were gathered by using data recorder. Computer communicates with the

data logger through GPIB(general purpose interface bus). Table 2 shows the cooling and heating test condition.

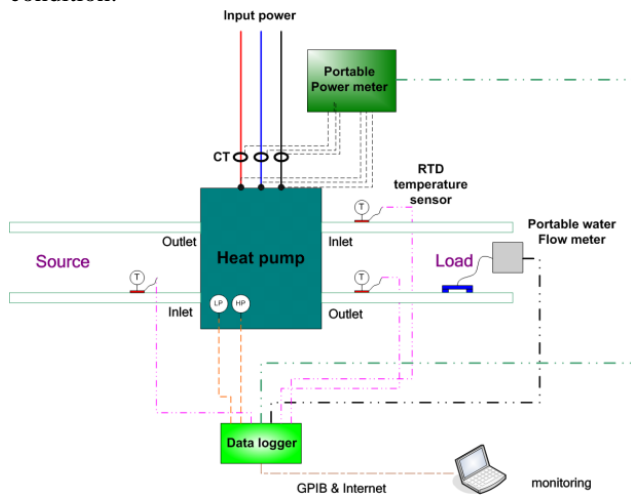

Figure 3. Actual performance data measurement points.

		1	2	3	4	5	6
Heating	EWT _S	10.0	4.40	1.70	1.70	4.40	10.0
	/	/	/	/	/	/	/
	LWT	46.1	46.1	46.1	54.5	54.5	54.5
cooling	EWT _S	21.1	21.1	26.7	26.7	32.2	32.2
	/	/	/	/	/	/	/
	LWT	7.2	10.0	10.0	7.20	7.20	10.0

Table 2. Heating and cooling test conditions.

Test result

Figure 4 shows all the test sequence 1) refrigerant recharge, 2) replacement compressor, 3) replacement expansion valve.

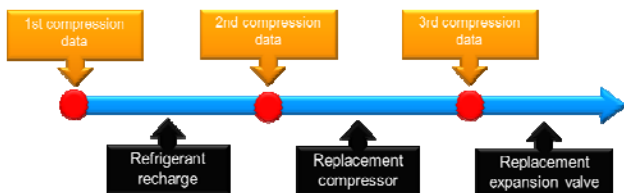

Figure 4. Initial commissioning test sequence.

Figure 5 shows the heating COP comparisons between the performance data as the initial actual field data. The heating COP was maximum -45.0% less in the performance data condition. Figure 6 shows the heating mode consumption power comparisons between the performance data as the initial actual field data. The

consumption power was maximum +14.0% more in the performance data condition. We can easily determine the status of the GHP system operation. System is operating in very bad condition and need repair.

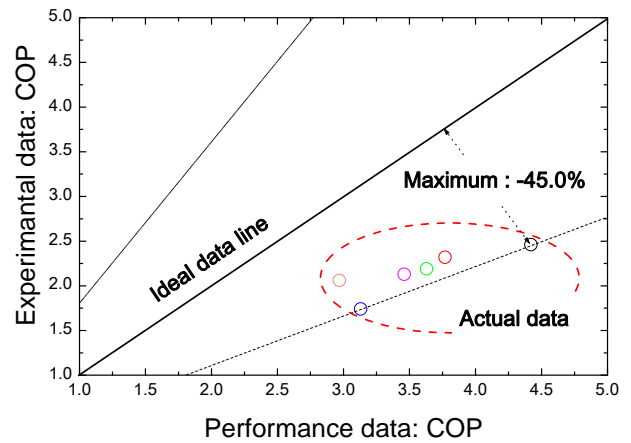

Figure 5. Comparison of COP with experimental data(initial heating test).

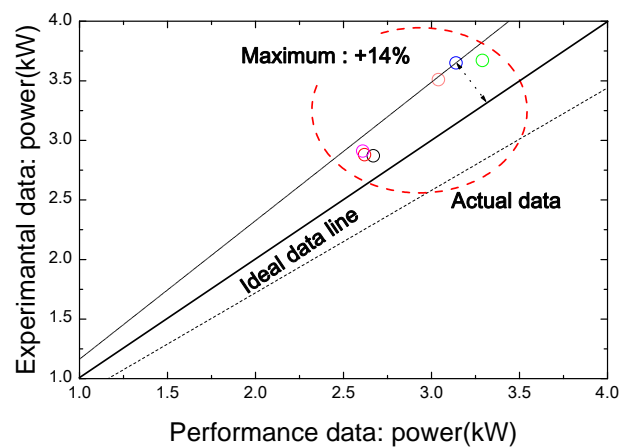

Figure 6. Comparison of power with experimental data(initial heating test).

As a first step, we determined that the right amount of refrigerant was recharged.

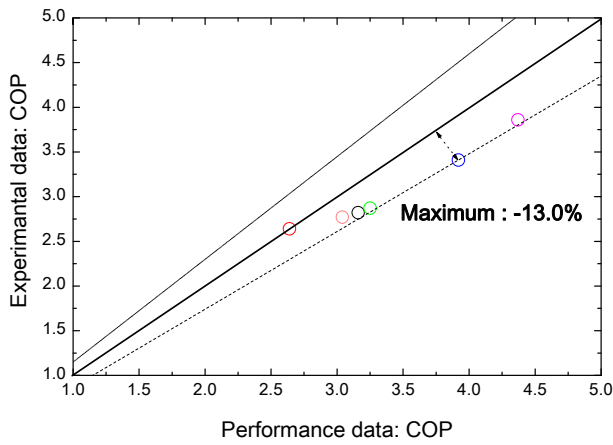

Figure 7. Comparison of heating COP(after refrigerant recharge).

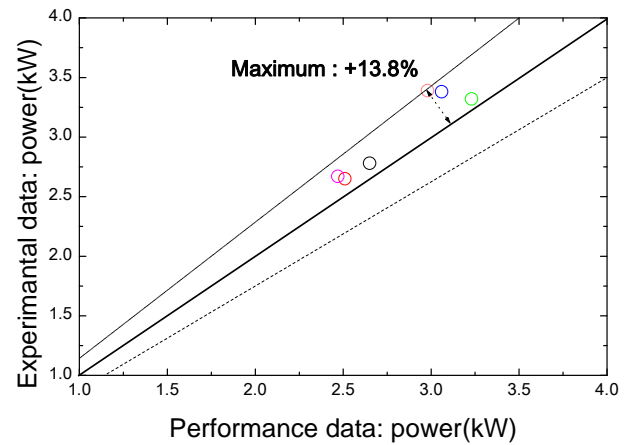

Figure 10. Comparison of power(after comp. replacement in heating mode).

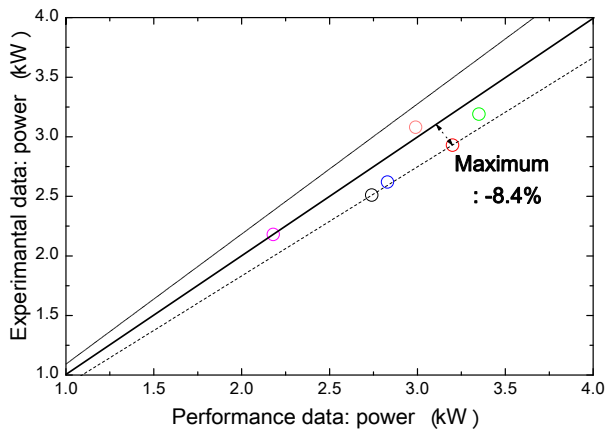

Figure 8. Comparison of power(after refrigerant recharge).

Figure 7, 8 shows heating COP and consumption power after refrigerants recharged, the COP has been increased to the performance data son up to maximum -13.0% from -45.0%, power reduce the gap between the performance data and the actual installed performance. Second step, we identify the state of the compressor. Because the compressor is a key component of heat pump system.

Figure 9, 10 also shows the improvement of heating COP as well as the power after replacement compressor process.

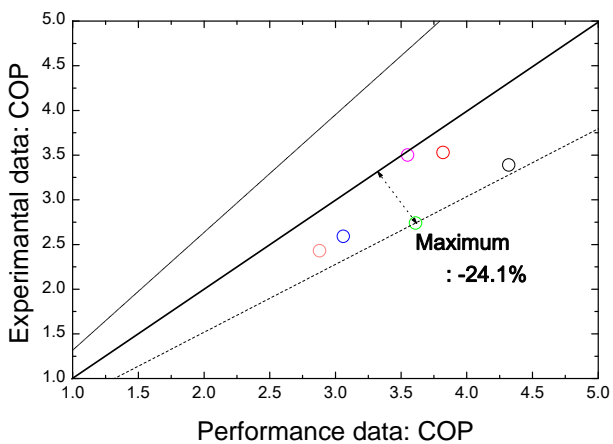

Figure 9. Comparison of heating COP(after comp. replacement).

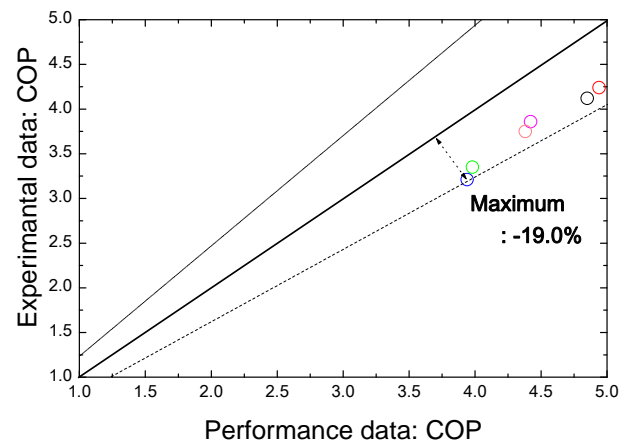

Figure 11. Comparison of cooling COP(after comp. replacement).

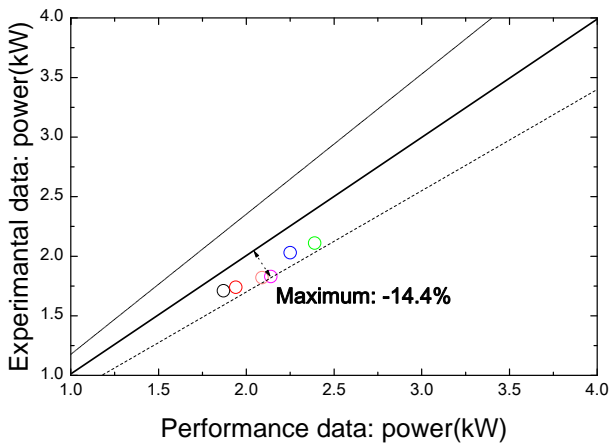

Figure 12. Comparison of power(after comp. replacement in cooling mode).

Figure 11, 12 shows Comparison of cooling COP and consumption power after replacement compressor.

	Heating		Cooling	
	COP	power	COP	power
Initial status	-39.5%	+11.9%		
After replacement compressor	-14.2	+8.1%	-15.1%	-11.2%
After replacement expansion valve			+3.1	-6.7%

But figure 9-12 shows performance gap is big between the performance data and the experimental data. And then In addition, we also measured the degree of superheat and subcool.

General heat pump system superheat range is 5-10°C, subcool range is 2-5°C. However, the actual system degree of superheat and subcool is about 20.7°C, 10.7°C. Degree of superheat or supercool are affected by expansion valve and the amount of refrigerant charge. So the heat pump was to replace the expansion valve.

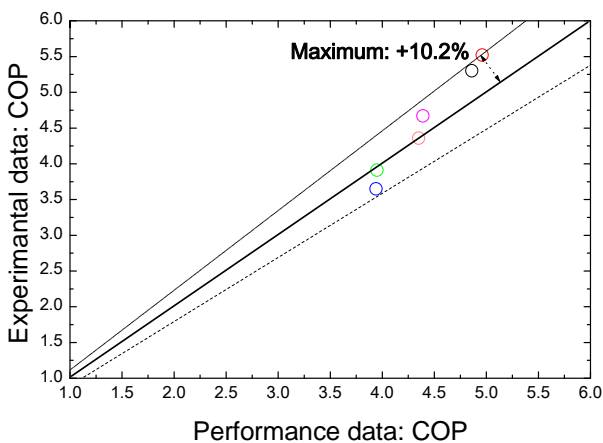

Figure 13. Comparison of cooling COP(after expansion valve replacement).

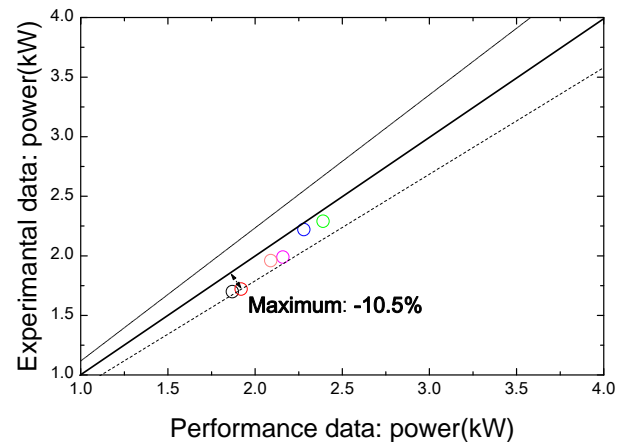

Figure 14. Comparison of power(after expansion valve replacement in cooling mode).

Table 5. Change for initial commissioning between performances.

Figure 13, 14 shows cooling COP and consumption power after expansion valve, the COP has been increased to the performance data son up to maximum +10.2% from -19.0%, power is reduce to -10.5% from 16.9%. And the average degree of supercool and subcool is 7.68°C, 3.11°C.

Table 5 shows Summarizes the overall test results and data is average value of six measurement points. According to new performance verification process, we can easily identify the GHP system problems and heating COP has been increased about 25.26% after replacement compressor also cooling COP has been increased about 15.1% after replacement expansion valve

CONCLUSION

This paper introduced a simple and clear method of performance verification and improvement technique based on the performance data and the actual field data.

A set of point or line from performance data provide a reference guideline to meet the target performance as in the actual situation. Key results indicated that this new approach could be better implemented in actual projects in a case of no clear reference to be commissioned. This more clear reference performance verification technique based on ISO manufacture data could reduce the gap between the performance data and the actual installed performance.

This new technique has been verified to actual water to water GHP system designed and installed at KIER site. The verification and improvement study showed that heating and cooling COP could be increased better up to about 25.2%, 15.1% with this proposed method. This performance verification technique could be better

applied to the present and future GHP projects to improve the system reliabilities and performance as promised in the design stage as in target manufacture performance data.

ISO 13256-2 Water-source heat pumps -- Testing and rating for performance - Part 2: Water-to-water and brine-to-water heat pumps.

REFERENCES

- G. H. Ko, J. Y. Kim, E. C. Kang, E. J. Lee, M. T. Hyun, 2007. "A study on Ground Source Heat Pump(GSHP) performance Measurement and Initial commissioning", Proceedings of The Korea Society of Heating, Refrigerating, and Air-Conditioning Engineers 2007 Summer Annual Conference, pp. 239-244.
- G. H. Ko, J. Y. Kim, E. C. Kang, K. C. Chang, E. J. Lee, 2008. "ISO performance data based commissioning technique for GSHP system", Journal of Geothermal Energy Engineers, Vol. 4, No. 2, pp. 1-7.
- J. C. Jang, J. Y. Kim, E. J. Lee, S. Y. Yoo, 2010. "A Study on the In-situ Performance Verification and Prediction Method of water to water GHSP System", Proceedings of The Korea Society of Heating, Refrigerating, and Air-Conditioning Engineers 2010 Summer Annual Conference, pp. 631-637.
- J. h. Yoon, E. J. Lee and D. E. Claridge, 2003. Calibration Procedure for Energy Performance Simulation of a Commercial Building," Journal of Solar Energy Engineering, Vol. 125, pp. 251-257.
- Bose, J. E., M.D. Smith, J.D. Spitler, 2002. "Advance in Ground Source Heat Pump system: An international over view, 7th International Energy Agency Heat Pump Conference, Beijing, May 2002.
- Joseph C. Lam, Wilco W. Chan, 2003. "Energy performance of air-to-water and water-to-water heat pumps in hotel applications", Energy Conversion and Management, Volume 44, Issue 10, June 2003, Pages 1625-1631.
- R.R. Zhang, X.S. Lu, S.Z. Li, W.S. Lin, A.Z. Gu, 2005. "Analysis on the heating performance of a gas engine driven air to water heat pump based on a steady-state model", Energy Conversion and Management, Volume 46, Issues 11-12, July 2005, Pages 1714-1730.
- T. Magraner, Á. Montero, S. Quilis, J.F. Urchueguía, 2010. "Comparison between design and actual energy performance of a HVAC-ground coupled heat pump system in cooling and heating operation", Energy and Buildings, Volume 42, Issue 9, September 2010, Pages 1394-1401.
- ISO 13256-1 Water-source heat pumps -- Testing and rating for performance - Part 1: Water-to-air and brine-to-air heat pumps.