

## IMPROVING THE WATER EFFICIENCY OF COOLING PRODUCTION SYSTEM

G.P. Maheshwari  
Senior Research  
Specialist

Y. Al-Hadban  
Associate Research  
Scientist

H. Al-Taqi  
Senior Research  
Associate

R. Alasserri  
Principal Research  
Technician

Department of Building and Energy Technologies  
Environment and Urban Development Division  
Kuwait Institute for Scientific Research  
P.O. Box 24885, 13109, Safat, Kuwait

### ABSTRACT

For most of the time, cooling towers (CTs) of cooling systems operate under partial load conditions and by regulating the air circulation with a variable frequency drive (VFD), significant reduction in the fan power can be achieved. In Kuwait and other counties of Arabian Peninsula, reduced airflow can lead to reduction in water consumption as well, since during the summer season, the dry bulb temperature of the ambient air is higher than the incoming hot water temperature, and the air undergoes sensible cooling. This paper presents the findings of a study conducted in the Avenues mall, Kuwait. Initially, the CTs operated only at high speed, and on a typical summer day nearly one fourth of the make-up water was used for self cooling of air. The study based on measured data revealed that the use of VFD can reduce the water wastage for self-cooling of air by as much as 75% and overall water consumption by 18.6% while keeping the cooling system performance at design level.

Keywords: Cooling towers, variable frequency drive, air self cooling

### INTRODUCTION

Cooling systems with water cooled (WC) condensers reject heat to water in a shell-and-tube heat exchanger, which is eventually transferred to the ambient air through humidification process in a cooling tower (CT). The water to be cooled is distributed in the CT by spray nozzles, or splash bars of film-type fill, which expose a very large water surface area to the ambient air (ASHRAE, 2005). Ambient air, generally circulated by fans, absorbs some of the water and the remaining water, achieves the desirable cooling by supplying the heat of vaporization. The energy transfer between the incoming hot water and the ambient air is predominantly a process of latent heating of air due to the mass transfer of water; the sensible heat transfer is also present to a certain extent, depending upon the difference between the CT entering water temperature (CTEWT) and the air-dry bulb temperature (DBT).

Furthermore, the thermal performance of a CT depends primarily on the entering air-wet bulb temperature (WBT) and its DBT has insignificant effect, however it does affect the water consumption. The difference between CT leaving water temperature (CTLWT) and the WBT is called CT approach ( $\Theta_{ct}$ ).  $\Theta_{ct}$  is a function of CT capability, and a large CT produces a closer approach for a given cooling load, water and air flow rates and entering air conditions (ASHRAE, 2004).

CT for an air-conditioning (A/C) system is selected for the maximum cooling load and for the worst design conditions of the place to ensure design performance during the adverse conditions. Thus, for most of the time, it operates under partial load conditions and/or favorable weather conditions. A commonly used control scheme for CTs for an energy conservation point is to maintain a constant CTLWT for different cooling loads and variations in WBT from the design conditions by regulating the air circulation through the CT (ASHRAE, 2004). The reduced circulation of air with the help of a VFD results in significant reduction in the fan power of the CT, although, some designers prefer to operate CT with constant airflow to achieve better chiller performance by supplying condenser water at lower temperatures under favorable weather conditions.

Reduction in sensible energy transfer between air and water is an additional effect of reduced airflow through the CT. This critical parameter is often ignored in most countries of North America and Europe since the ambient air DBT is lower than the incoming water temperature, and the air undergoes sensible heating, thereby, reducing the evaporation of water. It was estimated that the proportion of sensible and latent heat in cooling of the condenser water in most of the cities of USA for A/C applications is 30:70 (Burger, 1994). In Kuwait, situation is just the opposite. For most of the time during the summer season, the DBT of the incoming ambient air is significantly higher than the incoming hot water temperature, and the air undergoes sensible cooling.

This situation results in unwanted heat transfer from air to water, forcing increased vaporization of water to achieve the required cooling of water. Thus, any reduction in airflow in CT in Kuwait not only reduces energy consumption, but also minimizes water consumption. An analytical study using a computer simulation program (Intel, 1986) estimated a reduction in water consumption by nearly 25% for a building having 24 h occupancy in coastal area of Kuwait (Maheshwari and Al-Bassam, 2000).

#### WATER CONSUMPTION IN A COOLING TOWER

The water consumption in the CT is mainly due to the evaporation process. In case of zero sensible cooling transfer between the air and the water, it is the amount of water whose latent heat of vaporization ( $h_{fg}$ ) is equal to the sensible cooling or the heat rejection by the condenser water ( $Q_h$ ) in CT. The water consumption ( $W_{co}$ ) and  $Q_h$  are calculated as

$$W_{co} = Q_h / h_{fg} \quad (1)$$

$$Q_h = q_w \times \rho_w \times c_{pw} \times (CTEWT - CTLWT) \quad (2)$$

Where,  $q_w$ ,  $\rho_w$  and  $c_{pw}$  are the condenser water flow rate, density and specific heat respectively and  $h_{fg}$  is the latent of heat of vaporization of water. In Kuwait, the ambient DBT is higher than CTEWT for most of the time during the peak summer season. In such circumstances, the air, while cooling the water also gets cooled down, approaching CTEWT. As a result, additional water ( $\Delta W_e$ ) evaporates for this self-cooling of air. Reducing the air circulation through the CT can reduce  $\Delta W_e$ . However, for the moderate summer and winter seasons, DBT is less than the design CTEWT. During this period, air not only humidifies, but it heats up as well. The net result is a negative  $\Delta W_e$ .

Water blow down in CT, the amount of water discharged periodically as waste, so as not to let the salinity of the water in circulation exceed the critical level, is also significant. A sizeable amount of blow down water can be reused as make-up water after reducing its salinity through a reverse osmosis desalination system. The present study is however limited to optimization of the water consumption used for evaporation process ( $W_e$ ).  $W_e$ , the sum of  $W_{co}$  and  $\Delta W_e$  is determined as the difference of the make-up water to the CT ( $W_m$ ) and the blow down ( $W_b$ ).

$$W_e = W_m - W_b \quad (3)$$

For a given application of CT,  $\Delta W_e$  is directly proportional to the airflow rate ( $q_a$ ) and it is estimated as:

$$\Delta W_e = q_a * \rho_a * c_{pa} * (CTIAT - CTLAT) / h_{fg} \quad (4)$$

Where,  $\rho_a$  and  $c_{pa}$  are the density and specific heat of the air respectively, and CTIAT and CTLAT are its respective CT incoming and leaving DBTs. Thus, on a typical summer day,  $\Delta W_e$  can be minimized by operating the CT with less air flow. However a reduction in airflow or more specifically a reduction in air to water (G/L) ratio is found to have an adverse effect on CT performance, leading to a linear increase in its  $\Theta_{ct}$  (Al-Bassam et al., 2007) as follows:

$$\Theta_{ct} = m \times (G/L) + c \quad (5)$$

or

$$\Theta_{ct} = m \times (q_a / q_w) + c \quad (5)$$

Use of variable airflow (VAF) through the CT for minimizing the water consumption was studied in the Avenues mall, Kuwait. Initially, the CTs operated only at high speed although they had provision to choose low or high speeds through the building automation system.

#### DESCRIPTION OF COOLING PRODUCTION SYSTEM IN THE AVENUES MALL

The Avenues Mall, the largest mall in Kuwait, is Middle East's premier retail and leisure destination. It is built using environment friendly techniques. Phase 1 opened in 2007 with an area of 170,000 m<sup>2</sup> has over 150 shops, restaurants, Cineplex, hypermarket and an IKEA showroom. Working hours are from 10:00 to 22:00 h daily and cinemas operate between 11:00 and 3:00 h (Al-Hadban et al, 2010).

The cooling production system (CPS) in the Avenues mall is a chilled water system with water-cooled condensers (Fig. 1). The total connected load of the CPS is 6130 kW (Table 1) and its salient features are:

- High efficiency centrifugal chillers with water-cooled condensers that operate efficiently at full load and part load operation up to a minimum of 10% capacity and incorporate microprocessor technology, which facilitates easy control of chilled water temperature leaving the chiller.
- Dedicated primary chilled water pump, condenser water pump and CT for every chiller.
- Microprocessor-based control system in the chiller controls the chiller leaving water temperature with an accuracy of  $\pm 1^\circ\text{F}$  ( $\pm 0.55^\circ\text{C}$ ).

- Two-speed fans for CT.

Table 1. Details of the Cooling System of the Avenues Mall (Phase I)

S. No	Name of Component	Quantity	Connected Load (kW/Unit)	Total (kW)
1	Chillers	8+1	663	5304
2	Chilled Water Pump (Primary)	8+1	18.5	148
3	Condenser Water Pump	8+1	80	640
4	Cooling Tower Fans	8+1	44.7 / 18.6	358
Total Connected Load (kW)			6130	

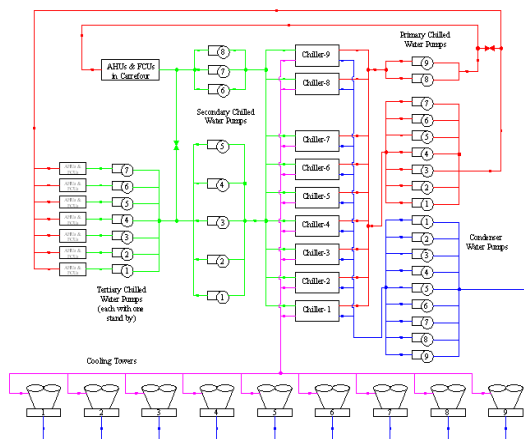

Fig. 1. Schematic diagram of the CPS of the Avenues mall (phase I).

RESULTS AND DISCUSSION

The CTs in the Avenues mall are selected for a heat rejection of 1125 RT per unit and for a  $\Theta_{ct}$  of 2.78°C. Based on the design WBT of 30.55°C, the CTs are expected to deliver water at 33.33°C. Water flow through each CT is maintained constant at 170.3 l/s (2700 USGPM) by a dedicated condenser water pump, while the airflow at high speed of the fan is 123 kg/s. Accordingly, the design G/L ratio of the CTs is 0.722. This is a water-efficient feature, since the common practice in Kuwait is to select a CT for a G/L ratio of 1.0. Thus, based on the design, the CTs

in the Avenues mall have 27.8% less air circulation leading a reduction in  $\Delta W_e$  by the same percentage.

Field data collected on a typical day, 10<sup>th</sup> of August 2008 were analyzed. Hourly profiles of ambient DBT and WBT for this day are shown in Fig. 2.

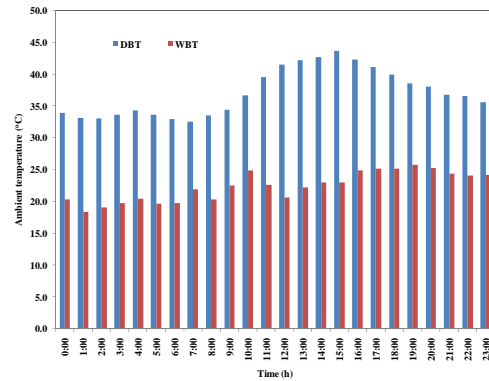

Fig. 2. Ambient air conditions on 10<sup>th</sup> August 2008.

Besides the plant room log book data, the additional data included the hourly amount of make-up and blow down water monitored through electromagnetic flow meters installed for the purpose of investigation. Number of operating CTs on this day ranged between 3 and 6, and the hourly measured amount of makeup water and the estimated amount of  $\Delta W_e$ , are shown in Fig. 3. As expected percentage share of  $\Delta W_e$  was higher during the day, directly in relation to the ambient DBT. Average CT leaving water temperature and average  $\Theta_{ct}$  at which the CTs were performing during peak hours (16:00 to 21:00 h) are shown in Fig. 4. Also, the proposed  $\Theta_{ct}$  at which to operate the CTs for a constant leaving water temperature at 33.3°C is shown in the same figure. Since the characteristics m and c for the CTs at the Avenues mall are not known, Eq. 5 cannot be applied right away to calculate the G/L ratio for proposed  $\Theta_{ct}$ . However, as per the selection of the CTs it is known that for a G/L ratio of 0.722, the  $\Theta_{ct}$  is 2.78°C. Accordingly, the Eq. 5 for the CTs of the Avenues mall can be modified as:

$$2.78 = 0.722 m + c \tag{6}$$

And the G/L ratio for the proposed  $\Theta_{ct}$  have been estimated for ‘c’ of 10 and 12. The results of the proposed airflow as percentage of the present flow for different c values are given in Fig. 5. The daily  $\Delta W_e$  for different ‘c’ along with its present value are shown in Fig. 6. Moreover, the percentage reduction with reference to the base case are shown in the same figure. Finally for a ‘c’ of 10, the water consumption

flow chart is shown in Fig. 7. The figure clearly show the importance of VFD as water efficient device as it can reduce the water wastage for self cooling of air by as much as 75% and overall water consumption by 18.6%.

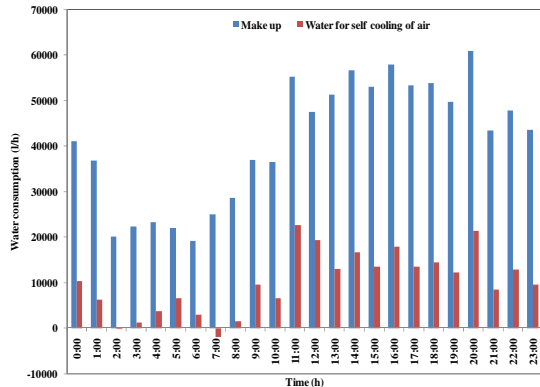

Fig. 3. Make-up water consumption along with the water used for self-cooling of the air.

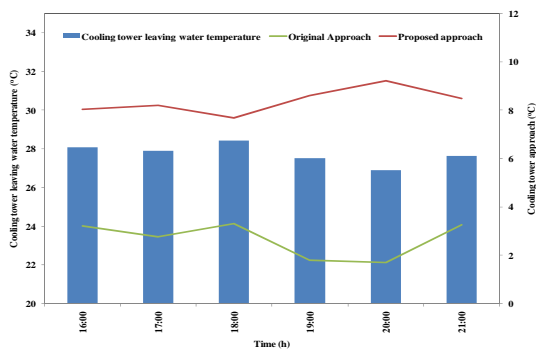

Fig. 4. Cooling water supply temperature and approach during peak hours.

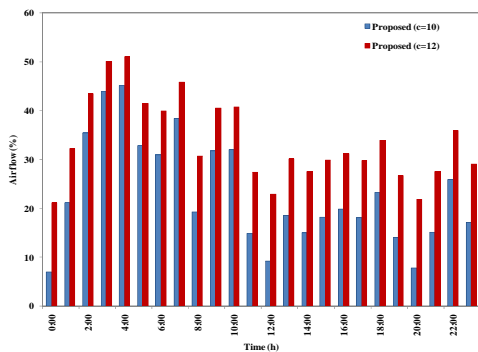

Fig. 5. Proposed airflow with different 'c' values.

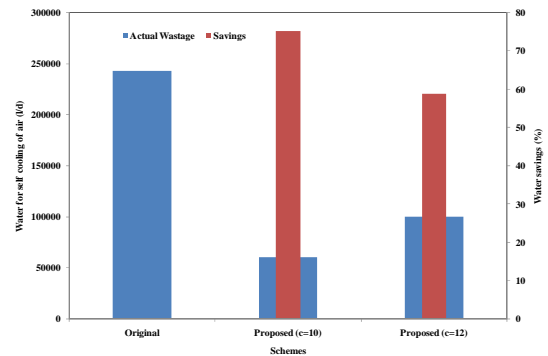

Fig. 6. Water for self cooling of air original and proposed.

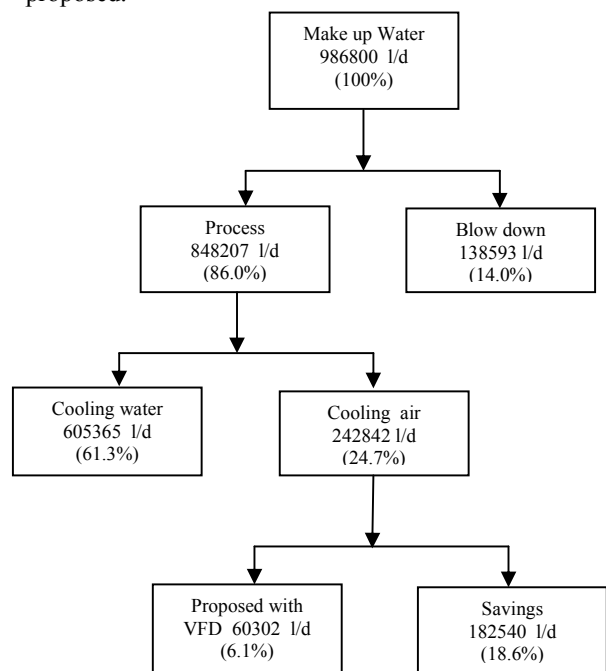

Fig. 7. Water flow diagram.

CONCLUSIONS AND RECOMMENDATIONS

1. CTs design for air to water ratio of 0.722 and use of two speed fan motors are strong water efficient features in the Avenues mall.
2. The field data collected on a typical summer day (10<sup>th</sup> of August 2008 ) with the wet bulb depression exceeding 20°C revealed that the fans were operating only at high speed, leading to nearly a quarter of water wasted for self-cooling of air.
3. It is recommended that fans be operated with VFD as water efficient device as it can reduce the water wastage for self-cooling of air by as much as 75% and overall water consumption by 18.6%.

## REFERENCES

- Al-Bassam, E., G. P. Maheshwari, R. Allasseri, 2008. Optimization of water and electricity consumption in cooling towers. Final Report (EU001C). Kuwait Institute for Scientific Research, Report No. KISR 8767R, Kuwait.
- Al-Hadban, Y., G. P. Maheshwari, H. Al-Taqi, D. Al-Nakib, R. Allasseri, 2010. Implementation of Energy and Power Saving Schemes in the Avenues Mall. Final report (EU051C). Kuwait Institute for Scientific Research, Report No. KISR 10100, Kuwait.
- ASHRAE. 2004. System and Equipment Handbook. American Society of Heating, Refrigeration and Air-conditioning Engineers, Atlanta, Georgia, USA.
- ASHRAE. 2005. Fundamentals. American Society of Heating, Refrigeration and Air-conditioning Engineers, Atlanta, Georgia, USA.
- Burger, R. 1994. Cooling Tower Technology. Third Edition, Indian Trail Liburn, Georgia, USA. Fairmount Press, Inc.
- Intel. 1986. Counterflow cooling tower. Software Program Intel86, version 1.0 Win, Thermal Analysis Company, USA.
- Maheshwari, G.P. and E. Al-Bassam. 2000. Optimization of water consumption of cooling towers (EE008K). Kuwait Institute for Scientific Research, Report No. KISR6026, Kuwait.