

AN OVERVIEW OF BUILDING AMERICA INDUSTRIALIZED HOUSING PARTNERSHIP (BAIHP) ACTIVITIES IN HOT-HUMID CLIMATES

S. Chandra¹, D. Parker¹, J. Sherwin¹, C. Colon¹, K. Fonorow², D. Stroer³, E. Martin¹, J. McIlvaine¹, D. Chasar¹, N. Moyer¹, S. Thomas-Rees¹, D. Hoak¹, D. Beal¹, C. Gil¹

¹ Florida Solar Energy Center (FSEC)

² Florida Home Energy and Resources Organization (FLHero)

³ Calcs-Plus

ABSTRACT

BAIHP (www.baihp.org) conducts systems research and technical assistance activities for new housing. Hot-humid climate efforts described here include:

Systems research : *NightCool* – A hybrid cooling and dehumidification strategy employing radiative cooling and desiccant materials. *Interior Duct Systems in Manufactured Houses* – Tests are ongoing in an occupied prototype home in Alabama and the FSEC manufactured housing lab. *Ventilation and Dehumidification* – A new strategy has been developed to hook up a whole-house dehumidifier so that it only runs when the air conditioning compressor is off. *Plug Load Reduction* – Whole house feedback devices and security system based plug load reductions are being evaluated in prototype homes. *Solar and Conventional Domestic Hot Water (DHW) Testing* – A test facility is being constructed to conduct side by side testing of three active and passive solar, two gas and two electric DHW systems.

Technical assistance was provided on the design, construction and evaluation of four near zero energy homes and over 300 highly energy efficient production homes in subdivisions during 2007 and 2008.

INTRODUCTION

According to the IPCC [2007], at over 56%, CO₂ emissions due to fossil fuel use is the largest source of global greenhouse gas emissions. Noted climate scientist Dr. Hansen has shown [Hansen, 2008] that in 2007, the five largest CO₂ emitting countries were China (20.8% of total emissions), U.S. (19.3%), India (5%), Russia (5%) and Japan (4%).

In the U.S., buildings accounted for 39% of the CO₂ emissions in 2005 with residential buildings accounting for more than half of the building sector -- 21.2% of all CO₂ emissions and 21.8% of the primary energy consumption in the U.S. [D & R International,

2007]. Thus CO₂ emissions in the U.S. attributable to residences equal about 4% of the world's CO₂ emissions, which is the same amount of emissions produced by the entire country of Japan.

There were 113 million households in the U.S. in 2005, and from 1975 to 2006, the number of new homes constructed per year varied between 1.3 and 2.1 million [D & R International, 2007]. In 2007, about 1.6 million new homes were completed – 76% of these were single family units, 18% multi-family units [Census, 2008a] and 6% factory manufactured homes [Census, 2008b] built to the HUD code [HUD, 2006], the only preemptive national code in the U.S. that can supersede local codes. In addition, about 2% of the single and multifamily housing are also built in a factory and are called modular homes. These modular homes are built to applicable state and/or local codes. For an excellent overview of manufactured and modular housing, see Roaf, Fuentes and Thomas [2007].

While older existing homes contribute most to greenhouse gas emissions and energy consumption, it is easier to design energy efficiency and renewable energy features into new construction. Accordingly, since 1995, the U.S. Department of Energy (DOE) Building America (BA) program has worked with the U.S. home building industry -- this has resulted in over 40,000 highly energy efficient new homes to date [DOE, 2008]. These homes include improved comfort, moisture control, and durability in addition to energy efficiency features that result in reduced call backs and higher profits for the home builder. The BA program competitively selects research teams that work with industry professionals to advance state of the art of housing science and provide technical assistance resulting in the construction of extremely energy efficient homes.

One BA research team is led by the Florida Solar Energy Center (FSEC). This team, called the Building America Industrialized Housing Partnership (BAIHP) is staffed by FSEC researchers as well as personnel from subcontractors Florida Home Energy and Resources Organization (FLHero), Calcs-Plus,

Washington State University, Oregon Department of Energy, RESNET and other subcontractors.

BAIHP is one of six competitively selected Building America (BA) teams and the only team that is led by a university, the University of Central Florida. BAIHP conducts systems research and provides technical assistance to factory and site builders in the hot, humid Southeast and the Pacific Northwest. This paper will not address BAIHP activities in the Pacific Northwest or BAIHP activities related to analysis or international standards. This paper will summarize progress of the BAIHP tasks below.

Systems research:

- *NightCool*
- *Interior Duct Systems in Manufactured Houses*
- *Ventilation and Dehumidification*
- *Plug Load Reduction*
- *Solar and Conventional Domestic Hot Water (DHW) Testing*

Technical Assistance:

- *Near Zero Energy Home Prototypes*
- *Community Scale Homes:*

In addition to the above tasks, considerable BAIHP work is currently in progress that is being described elsewhere in these proceedings. BAIHP work on affordable housing (Habitat for Humanity and Brownsville Affordable Housing Corporation) is described by McIlvaine et. al. [2008]. Work on factory built “green” and high performance homes is described by Thomas-Rees et. al. [2008]. A protocol for community scale, post-occupancy evaluations of energy savings, and indoor air quality of BAIHP and conventional homes is described by Martin et. al [2008].

SYSTEMS RESEARCH

NightCool

NightCool is an innovative hybrid cooling and dehumidification system that consists of a metal roof which serves as a large-area highly-conductive radiator. Paired with a sealed attic, this roof-integrated radiator is selectively linked by air flow to the main zone with to provide cooling. During the day, the main zone is decoupled from the attic, and there is no exchange of air between the two. Due to the thick, conventionally-installed insulation, there is minimal heat transmission as well. Though the main zone is cooled conventionally by an air conditioning unit, at night, when the interior surface temperature on the metal roof in the attic space falls two degrees below the desired interior thermostat set point the

attic and living zones get coupled. The return for the air conditioner is channeled through the attic space through electrically-controlled louvers with a variable speed fan. The warm air from the interior cools off at the interior side of the metal roof and then radiates the heat away to the night sky. As increased cooling is required, the air handler fan speed or runtime is increased. If the interior air temperature does not cool sufficiently, the air conditioner supplements *NightCool*. Also, if temperature conditions are satisfied, but relative humidity is not, a dehumidifier or other dehumidification system may be energized. The massive construction of the home interior (tile floor and concrete interior walls) stores sensible cooling to reduce space conditioning needs during the following day.

Side by side tests in scale test buildings (Figure 1) in central Florida indicate 7% to 25% cooling energy savings and superior dehumidification performance over best-in-class conventional construction (white metal vented roof and light colored walls). The lower savings were for the humid month of August and higher for the drier, summer month of May. More detailed data and analysis of the *NightCool* concept is available in a recent paper [Parker, Sherwin and Hermelink, 2008].



Figure 1. *NightCool* Building (left) and Control Building Under Test at FSEC

Interior Duct Systems in Manufactured Houses

Research since the 1980s has established leaky duct systems to be a prime cause of energy loss and poor indoor air quality in many residences. In manufactured homes, the problems can be especially acute due to crossover ducts built in the crawlspace and not always well connected. In response, BAIHP has worked with two industry partners (Southern Energy Homes and Cavalier Homes) to develop and test prototype manufactured homes with all duct work inside the air and thermal boundary. The Cavalier Home prototype used a floor duct system

with risers incorporated within the wall system. The Southern Energy Home system has a furred down interior duct system under the ceiling. Energy simulations were conducted on these prototypes. The Cavalier Homes prototype netted an annual energy savings (kWh) of 6.9%, as well as a savings in air conditioning and heating energy use (kWh) of 10.9% and 18.5%, respectively. In the Southern Energy Homes prototype, an annual energy use savings (kWh) of 10.4% was observed, while use of air conditioning and heat energy savings (kWh) totaled 13.5% and 20.5%, respectively. Progress to date, including measured performance data, is described in a companion paper elsewhere in these proceedings (Moyer et al., 2008)

Ventilation and Dehumidification

It is generally, but not universally, accepted among building scientists that some level of whole-house mechanical ventilation (WHMV) in energy efficient residences is desirable for acceptable indoor air quality (IAQ). This is in addition to local exhausts in bathrooms and kitchen. In the U.S., except for manufactured housing built to the HUD code, WHMV is currently required by code only in the states of Washington and Minnesota.

In homes constructed by production builders in the Gainesville, Fla., area without WHMV some occupants complained of odors in the late 1990s. In some other homes occupants complained of high humidities during the winter. In response, a simplified supply air ventilation system (consisting of a filtered air intake, 4" flex duct, manually set damper, and connected to the return air plenum) was developed. This provided 30 to 40 cubic feet per minute (cfm) of ventilation - a rate that is significantly lower than ASHRAE 62.2 - when the blower operated in these 2,000 to 3,000 sq. ft. homes. Since 1999, odors and high humidity complaints have not been reported in over 500 energy efficient homes built with this WHMV system as part of the BAIHP effort. We have not yet done formal surveys of occupants, or measurements of air quality indicators - VOC, CO₂, RH levels - so the lack of complaints cannot necessarily be equated to acceptable indoor air quality. Figure 2 shows some details of this WHMV system design. The air intake is from a clean, cool, elevated outdoor location, preferably outside the front door, and the flex duct connects to the return side of the air handler down stream of the main filter. Use of a manual butterfly damper can close off the outside air intake during periods when outside conditions are worse than interior, such as dust from road work, smoke from forest fires etc. When the air handler runs as the result of a call for heating or cooling, the system distributes the ventilation air throughout the

house through the supply ductwork. Occupants are instructed not to run the air handler in the constant "Fan On" position. A recent modification to the system substitutes a motorized damper in the intake ductwork that opens only when the compressor is turned on, assuring conditioning of the outdoor air.



Figure 2. Details of the WHMV system installed in over 500 residences in Gainesville, FL since 1999 without any reports of occupant complaints.

Dedicated Dehumidifier

Dedicated dehumidifiers are now installed in some of today's high performance homes, especially if year round RH control is desirable. A dedicated dehumidifier is one that uses an air duct system to take air from the conditioned space, dry it, and move it back to the conditioned space. The two ways to duct a dehumidifier are putting it on its own duct system, or integrating it with the air conditioning duct system. Both ducting methods have their benefits and drawbacks. The byproduct of a dehumidifier is liquid water and a small amount of sensible heat. The water is carried away through a condensate drain system. The sensible heat is moved into the conditioned space. If the dehumidifier is on its own duct system, the small amount of sensible heat can make an area of the conditioned space uncomfortable.

This can be avoided by integrating the dehumidifier with the HVAC duct system, but how to integrate the dehumidifier? While the dehumidifier output may be ducted into the supply or return duct work, we prefer ducting it to the supply ductwork and controlling the dehumidifier such that it will not operate while the AC system is in operation. The other benefit of this approach is higher energy efficiency since two compressors never run simultaneously. To achieve this, the dehumidifier must know when the AC system is in operation. This would be very easy to do if every AC manufacturer used the same control scheme in their equipment.

Unfortunately, this is not the case, and in this highly competitive market AC manufacturers have designed control circuits to do specific functions which they perceive will bring the most comfort to their customers. We have found that although the dehumidifier must know when the AC system is in operation, it is best that the control circuit of the dehumidifier not be integrated with the control circuit of the AC system.

The ducting and control schematic described here tries to address these issues. The duct system in Figure 3 shows a proposed method to accomplish the intent. The air handler has a typical supply and return duct system along with a dedicated out door air duct. The supply side of the dehumidifier is ducted into the supply side of the air handler. The return side of the dehumidifier is connected to its own return air grill(s), usually located in the main body of the home or in specific rooms of concern. But the return side of the dehumidifier should never be located in kitchens or laundry rooms.

The supply side of the dehumidifier incorporates a mechanical damper (dehumidifier supply damper, or DSD) to prevent back feeding through the dehumidifier when the AC system is in operation. The supply duct of the dehumidifier enters the main supply duct of the air handler in close proximity to the air handler fan.

The dehumidistat (H) should be located next to the thermostat (T) in the main living area of the home. They should be on an interior wall where it will not be affected by outdoor conditions or indoor heat loads from lighting or appliances.

The sail switch (SS), located in the return duct is there to let the dehumidifier know if the air handler is in operation. This keeps the control wiring of the dehumidifier separate from the rest of the HVAC system. It also keeps control wiring less complicated for technicians in the field.

Figure 4 shows the wiring schematic for the dedicated dehumidifier (DDH). The sequence of operation will be as follows: When the air handler is operating, the SS breaks contact from the dehumidistat to the dehumidifier and energizes the DSD.

When the air handler is off, the SS allows the dehumidistat to operate the dehumidifier and disconnects power to the DSD. Note that the dehumidistat built into the dehumidifier needs to be disabled so that only the house dehumidistat operates it.

This method allows the dehumidifier to operate when the air handler is not in operation. It also eliminates the energy penalty of two compressors running at the same time, trying to perform the same function - removing the moisture from the air.

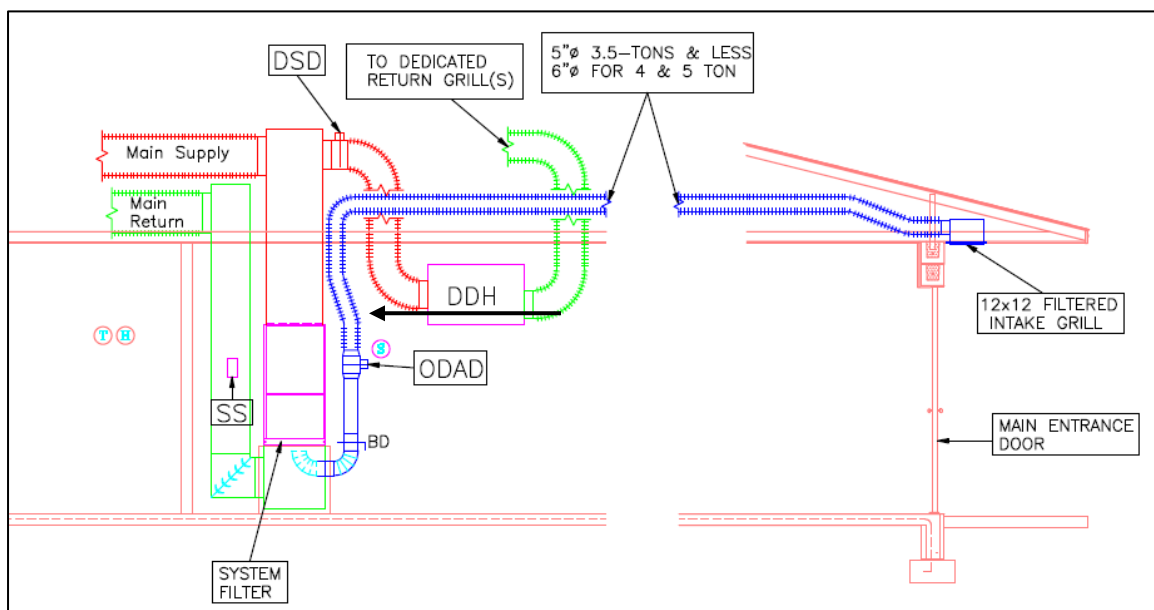

Figure 3. Proposed integration of dedicated dehumidifier w/ HVAC system

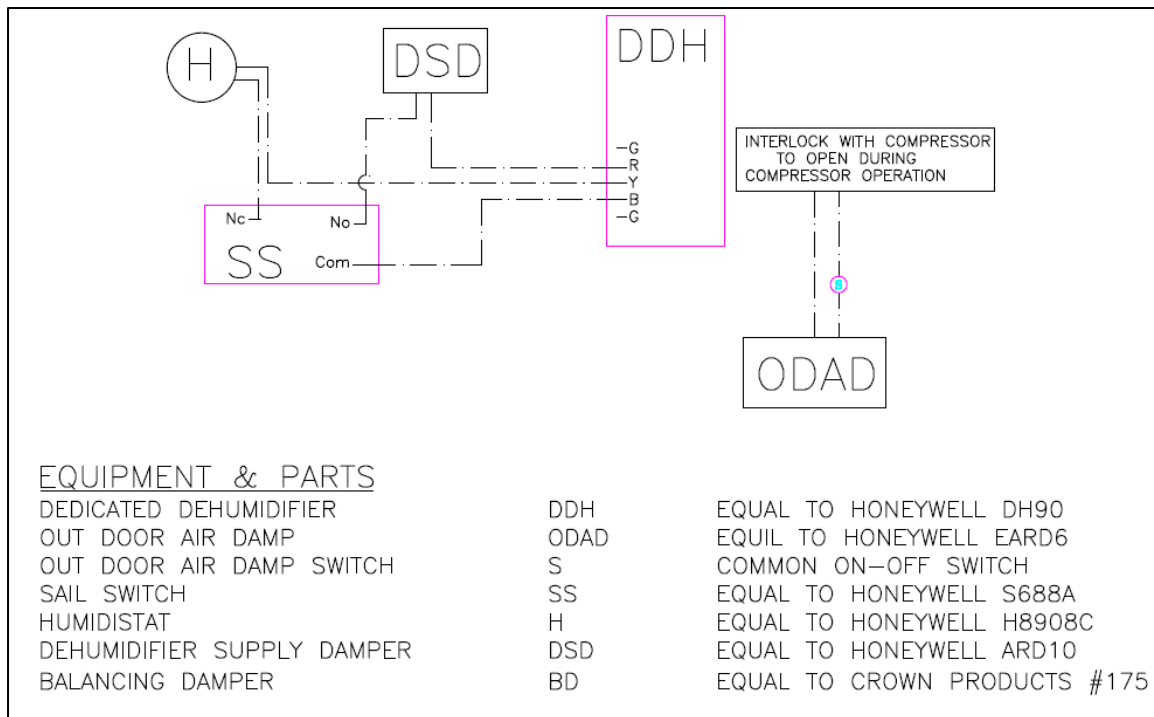

Figure 4. Wiring Schematic for the dedicated dehumidifier (DDH)

Plug Load Reductions

Today, the largest category of end use loads in a home is typically the plug loads, also known as miscellaneous electric loads (MELs). Measured data obtained on a sample of typical, all electric, single family detached homes in the late 1990s by the state's largest electric utility (Florida Power & Light Co., FPL) was kindly shared by FPL. That data, along with some climate statistics, is presented in Table 1.

Please note that through design and technology, builders and building scientists can have a major impact on reducing the cooling, heating and hot water energy use. But nearly half of the total energy use of a home comes from lighting, refrigeration, TVs, computers and other highly user and lifestyle dependent miscellaneous electric uses that are difficult to reduce. One way to cost-effectively reduce these miscellaneous loads is through the use of energy feedback devices that can reduce whole house electrical energy use by 5% to 10% [Parker, Hoak and Cummings, 2008].

Current BAIHP work is focusing on automatically shutting off lights, fans and other appliances when occupants are not in a room. Several approaches are being evaluated – some commercially available and others in development, such as having dedicated circuit breakers for some loads that can be automatically turned off by the house security system if it is in “away” mode.

Solar and Conventional Domestic Hot Water (DHW) Testing

Because of federal, state and local utility incentives, solar water heaters are being installed in significant numbers across the nation. It is an excellent way to save energy on water heating and whole house energy to meet the BA program goals. A test facility is currently being constructed at FSEC in Cocoa, Fla., to test seven side-by-side systems (Figure 5) and compare the energy performance of different types of solar and conventional water heaters, as well as their time-of-day electric loads. Another objective of this side-by-side testing is to enhance and validate simulation models for solar water heating systems, particularly the integrated collector and storage (ICS) systems.

The three solar collectors have been installed (Figure 6), and the tank and tankless systems are also procured and plumbed inside the test shed (Figures 7 and 8). The types of systems being set up for testing include a standard 50-gallon electric unit, flat plate PV-pumped direct solar water heating system, flat plate differential-controlled direct solar water heating system, integrated collector storage (ICS) system with a standard 50-gallon electric tank for backup, tankless gas water heater, a conventional gas water heater, and a tankless electric water heater. All systems should be operational by end of 2008. This work complements similar research done at NBS (now NIST) and FSEC in the 1980s.

Table 1. Characteristics of the Florida climate and measured data from typical homes

Climate Zone of Florida	Winter design Dry Bulb (F)	Summer design Dry Bulb (F)	Annual kWh of Typical Home	% kWh for central a/c	% kWh for central Heating	% kWh for water heating	% kWh for rest of the house
North	32F	94F	16,300	32.0%	7.2%	13.4%	47.4%
Central	38F	93F	17,200	37.8%	4.3%	13.1%	44.8%
South	47F	90F	18,100	41.5%	3.8%	12.0%	42.6%



Figure 5. The FSEC DHW Test Facility



Figure 6. The solar collectors, with the ICS system in the rear top



Figure 7. One half of the tanks inside the test shed.



Figure 8. The other half of the tanks in test shed.

TECHNICAL ASSISTANCE

Near Zero Energy Home Prototypes

A key BA activity is to provide technical assistance in the design, construction and evaluation of high performance homes. BAIHP has provided

assistance to four near zero energy homes (NZEH) recently (Figures 9 – 11). Table 2 summarizes their features.



Figure 9. The Schroeders Homes NZEH in North Port, FL. The PV array is split on south and west roofs. Trees shade part of the array and the solar DHW collector in the afternoon



Figure 10. The NZEH#1 (l) and NZEH#2 (r) by Schackow Realty and Development.



Figure 11. The NZEH by Stalwart Built Homes (l) with its geothermal ht. pump w/ heat recovery DHW (r)

Table 2. Selected Characteristics of Four Near Zero Energy Homes

	Schroeders	Schackow#1	Schackow#2	Stalwart Built
Location	North Port, Fl	Gainesville, Fl	Gainesville, Fl	Panama City, Fl
Conditioned Area, sq. ft.	1,446, one story	1,772 one story	1,520 one story	1,392 two stories
Completed	May 2008	June 2008	July 2008	February 2008
Occupancy as of August 08	6	2	unoccupied	1
Energy Feedback?	No	Yes, T.E.D.	Yes, T.E.D.	No
Foundation	Slab-on-grade	Slab-on-grade	Slab-on-grade	Vented crawl with R-13 foam
Walls	CBS w/R7.8	2 x 4 w/ R13	2 X4 w/R13	2 x6 w/R-19 batt
Roof /Attic	Shingles on radiant barrier decking / Vented attic w/R-38	Shingles on rad. barrier decking / Vented attic w/R-30	Galvalume/ Unvented attic w/ R- 24 foam	Galvalume/ Unvented attic w/ R-19 foam
Windows	U=.51, SHGC=.23	U=.34, SHGC=.28	U=.34, SHGC=.3 for most.	U=.35, SHGC=.25
Window/ Floor area %	10.8%	15.4%	14.2%	10.7%
Heating and Cooling	SEER18.4/HSPF 9.1 dual speed air source heat pump	SEER19, 2-speed a/c /95% gas furnace	Geothermal, open loop well	Geothermal, closed vertical loop
a/c size (@hi spd), sq. ft/ton	723	818	760	1,044
Dehumidifier	No	No	No	Yes
Hot water	Solar w/electric backup –open loop, pumped w/ 40 sf /80 gal. Tank	Solar w/electric backup, drainback system, w/ 64 sf /120 gal. tnk	Solar w/electric backup, drainback system, w/ 64 sf /120 gal. tnk	40 gal. electric w/ desuperheater
House ACH50	4.3	3.1	3.5	3.5
Duct leakage to out (CFM25 % of floor) & location	4.5%, ducts in attic	2.2%, ducts in cond. Space, furred down	Ducts in unvented attic	1.1%, ducts in unvented attic
Whole House Ventilation	Run time vent, 12 cfm	Run time vent, 29 cfm	Run time vent, 23 cfm	Run time vent, 35 cfm
Lighting	90% cfl	92% cfl	92% cfl	100% cfl
Appliances	E-Star dishwasher		E-Star fridge, washer and dishwasher	E-Star fridge and dishwasher
Photovoltaic system size	277 sq. ft., 3.4 Kw _p	247 sq. ft., 3.15 Kw _p	330 sq. ft., 4.2 Kw _p	328 sq. ft., 3.6 Kw _p
PV array orientation	½ south, ½ West	West	West	South
HERS Index	25	26	16	26
Green certification	No	No	No	LEED-H Platinum, first in Florida
Instrumented?	Yes, July 08	Yes, June 08	Yes, July 08	Yes, August 08

Performance of Two Homes

Monitored data from two of the occupied homes above (Schroeders and Schackow#1) are available for about a month this year. Table 3 shows some measured data.

The Schackow#1 home is performing close to design parameters with PV providing 80% of the electric load and solar thermal providing near 100% of the hot water load for this family of two.

However, despite the nearly same home size, HERS Index, and PV array, the Schroeders home with a family of 6 is using much more energy. PV is supplying about 25% of the demand, and the solar water heater is providing approximately 70% of the very high hot water load. These two homes clearly demonstrate the huge effect occupants have on the energy performance of a home.

The cooling performance of different homes in different climates can be compared, to the first order, following the methodology of Chasar et al. (2006). Figure 12 shows the data for these two homes and compares it to two other homes measured earlier, which bounds the data for all homes analyzed prior to this year by BAIHP. The performance of these two NZEH is excellent, and the Schackow#1 is performing slightly better than the previous best home. The slope of the Schroeders home is also quite good, and the larger intercept is probably explained by the high occupancy and thus higher internal loads.

Community Scale Houses

BAIHP partner home builders have been building energy efficient homes with a HERS Index of 70 or less for the past few years with technical assistance provided by BAIHP team member FLHero. Noteworthy among them are G.W. Robinson Builders and Tommy Williams Homes that have together built over 150 homes that meet this performance level in the Gainesville, Fla., area (North FL climate). G.W. Robinson Builder homes are larger, semi-custom homes built for the move-up buyer. Tommy Williams Homes are entry level homes.

These two builders construct homes that are energy efficient and feature improved indoor air quality and comfort. Both companies built 50 to 100 homes per year in multiple communities in the greater Gainesville area during 2007. The two builders both committed to building 100% of their homes according to the Building America process, which is fundamentally different than current building standards in terms of whole-house systems being engineered and commissioned to be

significantly more energy efficient, comfortable, and with improved indoor air quality. All finished homes must undergo a seven-facet performance test for commissioning and feedback to the builders. These performance tests include whole house air tightness, duct system air tightness, pressure mapping, outside airflow measurement, static pressure, temperature drop, and exhaust fan air flow measurement. Once these tests have been completed, the homes are given a HERS Index rating calculated by FSEC's EnergyGauge[®] software. Homes typically achieve a HERS index score of between 60 and 70. This significantly exceeds the EnergyStar level of performance (HERS Index of 85 or less) for this climate. Further specifications and economics of these homes are available in a previous paper. (Fonorow et.al. 2007).

Sales and Marketing

G.W. Robinson Builders and Tommy Williams Homes have both made energy efficient construction a standard feature of their homes. Both companies are committed to providing high quality, high performance, energy-efficient homes for their customers, and all of their homes are built to Building America standards. The owners also have expended significant effort and funds in sales and marketing, such as frequent newspaper and magazine advertisements; so that prospective home buyers are attracted to the model and can then talk to knowledgeable sales personnel about the homes' features. Particularly noteworthy is the Tommy Williams Homes sales center at the Longleaf Village, where prospective buyers can see and experience the benefits of low-E windows, radiant barrier roof decking and better insulation through well designed interactive displays. These displays were developed by Mr. Todd Louis of Bosshardt Realty who ran the sales center from late 2006 through mid-2008. Longleaf Village is a community of several hundred homes where two builders sell homes -- Tommy Williams Homes (TW) and a competitor who sells homes with nearly code minimum energy efficiency features. Both builders have equal number of lots to build on. In 2007, according to the public records, the competitor homes were sold at a lower price per sq. ft (\$148/sq. ft.) than TW homes (\$161/sq. ft.) -- yet more TW homes were sold than the competitor in 2007. In an 18-month period starting in December 2007, 42 homes were sold by TW versus the 22 sold by the competitor. In 2006, before the TW sales center was revamped, the situation was reversed -- more competitor homes were sold than TW (40 vs. 26). This proves that it is not sufficient to incorporate the technical features alone. A significant sales and marketing effort needs to be made to increase the market share of energy-efficient housing.

Table 3. Measured Performance of two Near Zero Energy Homes

	Schroeders	Schackow #1
Data Period	7/28/08 – 8/30/08	7/15/08-8/15/08
Total House Kwh used /day	49.4	11.7
PV supplied by inverter, kwh/day	12.6	9.3
PV supplied kwh/day per Kw _p of rating	3.74	2.95
% house kwh supplied by PV	25.5%	79.5%
Hot water consumed / day	134	n/a
Backup kwh for water heating/day	4.95	0.03
Average Interior Temp	76.7 F	77.1 F
Average Interior RH	57%	53%

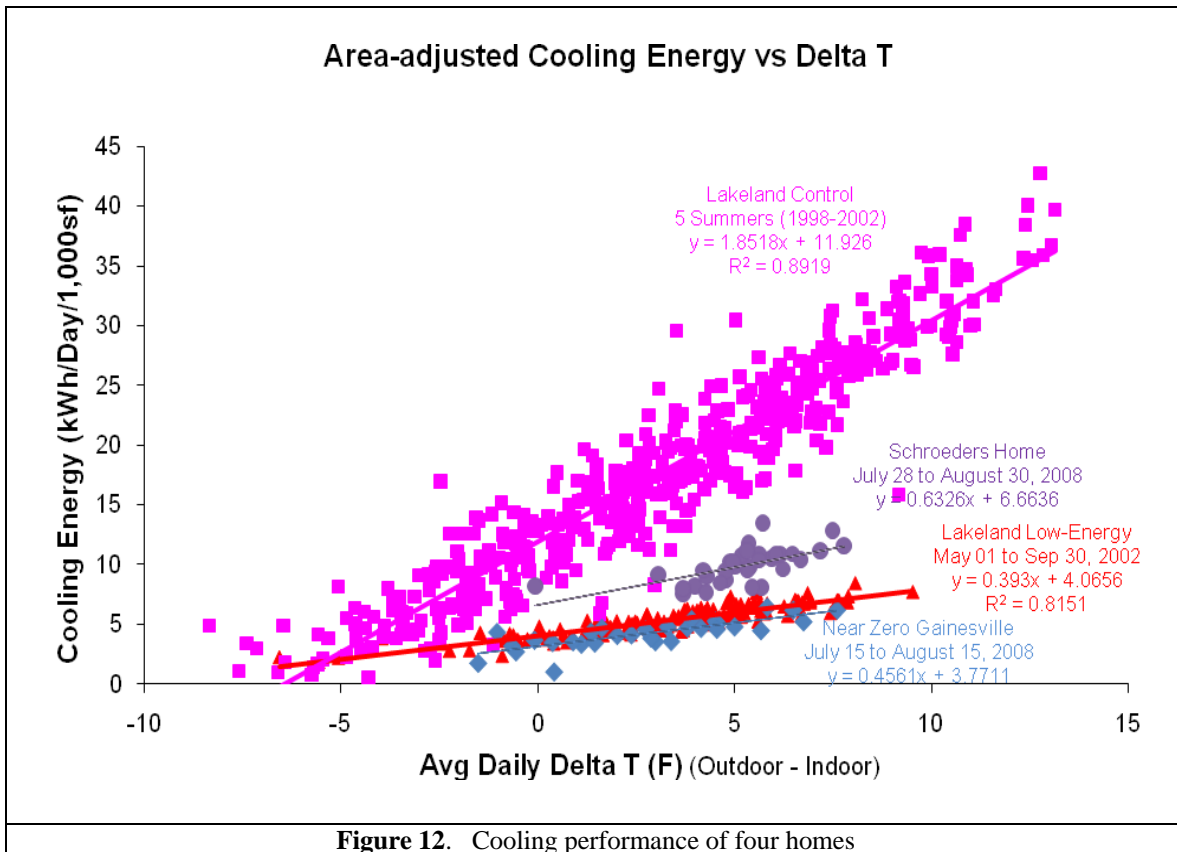

Figure 12. Cooling performance of four homes

CONCLUSIONS

BAIHP is working in several research areas to advance the energy efficiency and overall performance of new homes in hot, humid climates. Noteworthy accomplishments and findings to date:

- Development of the *NightCool* concept to cool and dehumidify using the night sky. This is proving to be an effective method even in hot, humid climate. Potential should be substantially greater in mixed-humid and arid climates.
- Construction and evaluation of manufactured home prototypes incorporating interior duct systems. This shows promise to be a cost-effective high performance option.
- Development of innovative ways to provide whole house ventilation and dehumidification
- Whole house energy feedback devices are useful for reducing energy usage for motivated households.
- Development of a test facility to conduct side-by-side testing of solar and conventional domestic hot water systems
- Near zero energy home prototypes once again show the power of homeowner lifestyles. Homes with nearly identical technical features are having very different purchased energy amounts due to differences in number of occupants and lifestyles
- Home Builders that adopt the Building America whole house system engineering principles and do an effective job of sales and marketing can realize quicker sales which equates to higher profits.

ACKNOWLEDGEMENT

This work is sponsored by the U.S. Department of Energy (DOE), Office of Energy Efficiency and Renewable Energy, Building America Program under cooperative agreement number DE-FC26-06NT42767. The support and encouragement of program managers -- Mr. George James, Mr. Terry Logee, Mr. Ed Pollock and Mr. William Haslebacher is gratefully acknowledged. This support does not constitute DOE endorsement of the views expressed in this paper.

We appreciate the collaborations of our builder, developer and realtor partners, especially those whose work has been featured in this paper --

Schackow Realty and Development, Schroeders Homes, Stalwart Built Homes, G.W. Robinson Builders and Tommy Williams Homes and Mr. Todd Louis of Bosshardt Realty.

We thank Mr. Philip Fairey and Mr. Rob Vieira of FSEC for their advice and support in conducting many aspects of this work and Ms. Sara Tournade for her skilful editing of this paper.

REFERENCE

Census. 2008a. U.S. Census Bureau, *New Residential Construction*, <http://www.census.gov/const/www/newresconstindex.html>

Census 2008b. U.S. Census Bureau, *Shipments of new manufactured homes 2005-2008*, <http://www.census.gov/const/mhs/shipment.pdf>

Chasar, D., Chandra, S., Parker, D., Sherwin, J., Beal, D., Hoak, D., Moyer, N., McIlvaine, J. 2006. *Cooling Performance Assessment of Building America Homes*, Fifteenth Symposium on Improving Building Systems in Hot and Humid Climates, July 24-26, 2006 Orlando, FL

D & R International. 2007. *2007 Buildings Energy Data Book*, September 27, 2007 <http://buildingsdatabook.eere.energy.gov/docs/2007-bedb-0921.pdf>

DOE 2008. U. S. Department of Energy Building America program website www.buildingamerica.gov

Fonorow, K., Chandra, S., McIlvaine, J., Colon, C. *Commissioning High Performance Residences in Hot, Humid Climates* Proceedings, 7th International Conference for Enhanced Building Operations, November 1-2, 2007, San Francisco, California. <http://www.fsec.ucf.edu/en/publications/pdf/FSEC-PF-430-07.pdf>

Hansen, J.E. 2008. *Global Warming -- Tipping Points: Presentation at the National Press Club, and briefing to the House Select Committee on Energy Independence & Global Warming - June 23, 2008* <http://www.columbia.edu/~jeh1/>

HUD, 2006. U.S. Housing and Urban Development, *PART 3280--MANUFACTURED HOME CONSTRUCTION AND SAFETY STANDARDS*, http://www.access.gpo.gov/nara/cfr/waisidx_06/24cfr_3280_06.html

IPCC 2007. Intergovernmental Panel on Climate Change - *Climate Change 2007: Synthesis Report - Summary for Policymakers*
http://www.ipcc.ch/pdf/assessment-report/ar4/syr/ar4_syr_spm.pdf

Martin, E., Chandra, S., Fonorow, K. and A. Koterba. 2008. "Research Plan for Post-Occupancy Evaluation of Building America (BA) vs. Non-BA Homes", *Proceedings - Symposium on Improving Building Systems in Hot and Humid Climates, Plano, Tx. Dec 15-16, 2008*

McIlvaine, J., Beal, D. and S. Chandra. 2008. "High Performance Affordable Demonstration Houses", *Proceedings - Symposium on Improving Building Systems in Hot and Humid Climates, Plano, Tx. Dec 15-16, 2008*

Moyer, N., Stroer, D., Hoak, D., McIlvaine, J. and S. Chandra. 2008. "Research Results From A Few Alternate Methods of Interior Duct Systems in Factory Built Housing Located In The Hot Humid Climate", *Proceedings - Symposium on Improving Building Systems in Hot and Humid Climates, Plano, Tx. Dec 15-16, 2008*

Parker, D., Sherwin, J., and A. Hermelink, 2008 "NightCool: A Nocturnal Radiation Cooling Concept", *Proceedings of ACEEE 2008 Summer Study on Energy Efficiency in Buildings, American Council for an Energy Efficient Economy, Washington, DC, August 2008.*

Parker, D.S., Hoak, D. , and J. Cummings. 2008 *Pilot Evaluation of Energy Savings from Residential Energy Demand Feedback Devices*. Contract Report, Florida Solar Energy Center.
<http://fsec.ucf.edu/en/publications/pdf/FSEC-CR-1742-08.pdf> , January 2008

Roaf, S., Fuentes, M., and S. Thomas. 2007. *Ecohouse: A Design Guide, 3rd ed.* pp. 448-457. Elsevier. 2007.

Thomas-Rees, S., Chasar, D., Chandra, S. and D. Stroer. 2008. "Green and High Performance Factory Crafted Housing", *Proceedings - Symposium on Improving Building Systems in Hot and Humid Climates, Plano, Tx. Dec 15-16, 2008*