

## A Prediction of Energy Savings Resulting from Building Infiltration Control

Ken McWatters  
Houston Lighting & Power

David E. Claridge  
Texas A&M University

Mingsheng Liu  
Texas A&M University

### Abstract

Heat transfer through building walls consists of three main components: conduction heat transfer, solar gain and infiltration heat transfer. An interaction among these three heat transfer components alters the effective heat transfer through a wall, working to reduce or increase it. This study uses simulation to evaluate the potential energy impact of the interaction when several different strategies for controlling air leakage direction and velocity in building envelope components are implemented.

The simulations performed in this study show that significant energy savings can

airflow control is not recommended in cool climates.

### Nomenclature

$A$	Surface area of a building wall, window or roof
$c_p$	Specific heat of air
$I_{total}$	Total solar radiation incident on a building exterior surface
$m$	Air mass flowrate
$Q$	Heat transfer
$R_{bo}$	Thermal resistance of the boundary layer of air just outside a building wall
$R_{total}$	The sum of $R_w$ and $R_{bo}$ for a given building surface
$R_{...}$	Thermal resistance of a wall

airflow through non-airtight walls in a building. Comparing the energy load of a building which uses airflow control in its walls with the energy load found with a standard calculation (where the interaction effect is not considered), annual energy load savings were found in a warm climate as high as 17%. The results were less promising when compared against the performance of a building experiencing simulated natural airflow (and heat recovery) through its exterior walls: the best annual load savings percentage was 10% in a warm climate. It was found that in a cooler climate, the natural flow configuration performed about as well as any of the artificial airflow configurations, so

$SF$	Building exterior surface solar factor
$\Delta T$	Difference between building room temperature and ambient temperature
$U$	Heat transfer coefficient of a material
$\alpha_s$	Radiation absorptivity of a building exterior surface
$\alpha_w$	Nondimensional building wall airflow rate
$\beta$	The nondimensional value of $R_w$ divided by $R_{bo}$ , for a given building surface
$\theta$	Nondimensional temperature ratio for a building surface
$\phi$	Modified air mass flowrate

## Introduction

Heating and cooling of residential and commercial buildings makes up 36% of national energy expenditures [EIA, 1992]. Therefore, significant amounts of energy savings can be achieved if the load on heating and cooling equipment in homes and businesses is decreased in a cost-effective manner. This paper explores a unique ventilation procedure promoting wall heat recovery in buildings, which has seen only limited previous study, that may lead to new energy savings by reducing these heating and cooling requirements.

An energy load is created in a building by conduction heat transfer and by air flows through the building walls or roof (passing through cracks around window and door frames, or through the walls/roof themselves), if there is a temperature difference between the indoor and outdoor air. Recently, it has been recognized that some of the heat energy of this air is transferred to or from material in the wall or roof, and that this heat transfer can cause the total building energy load to be less than that predicted by a standard calculation. Such a standard calculation defines energy lost from a building due to air flowing across the building envelope as simply the enthalpy difference between the indoor and outdoor air times the air mass flowrate. Actually, this energy flow altered by the interaction between the heat flow of the air moving through the building wall/roof and the heat conducted through the wall/roof, which is affected by the indoor-outdoor temperature differential as well as the heat being gained due to solar radiation

on the wall/roof. This alteration of the heat flow across the building envelope can be termed the "interaction effect."

For purposes of this study, a simplified heat transfer model of a building is used to calculate the heat balance across a building envelope, according to a standard equation and an equation accounting for the interaction effect, and others where air flow patterns through building walls/roof are varied. A computer simulation program written for this study applies the heat transfer models through iterative loops, making hourly calculations over periods of up to one year. Climatological weather files (in the standardized, Typical Meteorological Year [1988] format) are input into the computer program, so that effectively, a building's heat transfer behavior is modeled over time for any given climate. By comparing the results found with the two models, hourly, monthly or annual energy load savings that are achieved with the interaction effect vs. the standard model are calculated with the computer simulation.

## Literature Review

The first attempts to intentionally induce air flow through building walls to save energy were made in Sweden in the 1970s [Solplan Review, 1991]. Various studies have been made since then of the impact of a ventilated wall, or "dynamic wall," on energy use in buildings, mostly to analyze the conduction/infiltration heat transfer interaction, but not the impact of solar gains on the building envelope.

A study by Virtanen [1991] of a theoretical dynamic wall predicted 6 to 9% energy load savings over a standard calculation of energy load. Anderlind [1985] predicted that as much as 100% of the infiltration heat transfer could be recovered in a dynamic wall, but the efficiency of the wall heat recovery was proportional to the diffusivity of the air flow through it. Wall air flow diffusivity is difficult to determine in the field, so it was determined that this theoretical study could not easily be applied to a real building for modeling. Studies by Kohonen and Virtanen [1987] and Dubois [1983], which included experimental analyses of houses in the heating season, found total heating load reductions of near 15% and 10%, respectively. The theoretical study of a dynamic wall by Bailly [1987], which included an average seasonal coefficient based on weather/solar influence, gave savings as high as 15% due to the interaction effect.

More recent studies began to include more comprehensive models of the interaction effect in a building envelope which included the solar heat gain. These included studies by Liu and Claridge [1992a and 1992b], where annual energy load savings ranged from 5 to 14%, while a projection of energy load savings as high as 35% was made for a building accounting for the solar gain on the walls. Vaidya [1993] measured the interaction effects in a small house and found that they reduced the load impact of air leakage by approximately 50%.

None of the previous studies have evaluated the impact of the interaction

effect in multiple climates over an annual cycle. This study evaluates the annual impact of several different air-flow control strategies in a hot, humid climate (Houston, TX) and a cool, cloudy climate (Seattle, WA).

### **Basic Concepts - the Heat Transfer Models and the Interaction Effect**

Briefly, the heat transfer models which are used to simulate a building in this study should be described. In the simplified models applied for this study, heat transfer is considered a one-dimensional flow through a wall. For a whole-building simulation, heat transfer analyses are conducted on each exterior wall and the roof (which is assumed to be flat), and the resulting net heat flows are summed to give the overall envelope heat balance. Standardized equations taken from the ASHRAE Handbook of Fundamentals [1993], which approximate the building internal load, ground heat transfer, and window solar heat gain, are added to this heat balance. The summation of all of these parameters gives the building heat balance, or heating/cooling load. This value represents the amount of heating, if positive, or cooling, if negative, that the air conditioning/heating system of the building needs to supply to maintain the indoor air temperature at a constant room temperature of 25°C. The difference between the standard, or classical heat transfer model result and the interaction heat transfer model result then represents the energy load savings (or deficit) that the interaction effect would provide over a standard building calculation.

Simple heat transfer analysis is applied to derive the classical and interaction heat transfer models used in this study. Both models account for three main components of heat transfer through/via a building wall or roof: conduction, solar gain and infiltration. The sum of these heat transfer components can be written as:

$$Q_{\text{wall/roof}} = Q_{\text{conduction}} + Q_{\text{solar gain}} + Q_{\text{infiltration}} \quad (1)$$

The classical model of heat transfer, as derived in Liu [1992] and McWatters [1995], contains the heat transfer expressions corresponding to the three components of equation (1):

$$Q_{\text{classical}} = UA\Delta T + \left(\frac{R_{\text{bo}}}{R_{\text{total}}}\right)A(\alpha_s I_{\text{total}}) + m c_p A \Delta T \quad (2)$$

Meanwhile, a more complex derivation is made in Liu [1992] and McWatters [1995] to arrive at the interaction heat transfer model. It contains the same heat transfer components as the classical model, but it appears somewhat different. It is written in its simplest form as

$$Q_{\text{model}} = (1 - \theta) \frac{-\phi}{R_w} A \Delta T \quad (3)$$

where

$$\theta = \frac{\alpha_w + \phi - SF \cdot R_w}{\phi - \beta} \quad (3a)$$

$$\phi = \frac{\alpha_w e^{\alpha_w}}{1 - e^{\alpha_w}} \quad (3b)$$

Three additional gain terms are added to both the classical and interaction heat

transfer values to give the total building heat balance for each model. As mentioned earlier, these terms account for internal heat gains, ground heat transfer and window solar heat gain. The resulting total building heat balance might be written as

$$Q_{\text{classical,bldg}} = Q_{\text{classical}} + Q_{\text{gains}} \quad (4)$$

$$Q_{\text{model,bldg}} = Q_{\text{model}} + Q_{\text{gains}} \quad (5)$$

Energy load savings which are generated by the interaction effect can then be calculated with the equation

$$\text{Savings} = \frac{Q_{\text{classical,bldg}} - Q_{\text{model,bldg}}}{Q_{\text{classical,bldg}}} \times 100\% \quad (6)$$

In the classical model, airflow is considered not to interact with building walls. In a practical sense, such a condition of non-interaction might be represented by a house where air flows through large cracks around doors, or a building which is well-sealed, incorporating outside air intake and exhaust ducts, to circulate fresh air to the rooms inside. Applied to such a building, the interaction model would reflect the same energy usage as the classical model, and energy savings would be zero. Energy savings in other buildings, then, would reflect the degree to which airflow through, and efficient heat transfer within, the walls is permitted.

Most real buildings do not fit the non-interaction criteria just described, and do not match the behavior of the classical model. Instead, in most buildings there is appreciable air

leakage through the walls/roof. The modifications recommended by this study, for the most part, just serve to enhance the interaction already occurring in the walls/roof of a building. Therefore, a more realistic measure of energy savings with respect to a preexisting condition should also be calculated by this study. As is shown in the next section, a calculation is made where the term  $Q_{\text{classical,bldg}}$  in equation (6) is replaced with an energy load value that results from a simulated natural flow condition in building walls. This alternative savings value should provide a more realistic evaluation of the benefit of a retrofit. Beyond this attempt to make this study's energy savings predictions more meaningful, the results of this study should also prove to be a useful design tool; as is shown in the next section, a major objective of the results is to find, by comparison, the best way to arrange building wall airflow direction and magnitude in a retrofit, where feasible, to produce the most interaction effect energy savings.

### Simulation Results

The equations presented in the last section have been applied with iterative routines in a building computer simulation program, written and developed especially for this study [McWatters, 1995].

There are many different combinations of airflow pathways that could exist in a building's exterior walls, which all create the same building air change rate (ACH). Treated classically, infiltration heat transfer is the same for all such

combinations which create the same building ACH. The simulations applied for this study analyze the building heat transfer balance, with the classical and interaction models, for several of these airflow patterns. The difference between the two model results indicates the energy load savings for each airflow pattern. The simulation results can thus be used to indicate the optimum airflow pattern, by identifying the pattern which creates the most building energy savings. This process is carried out in more than one climate, because the optimum airflow arrangement may not be the same when the mean ambient temperature and sun angles are different.

The results found with the building computer simulations are presented here in graphical and tabular form for brevity and clarity, and the most significant results are described in detail. All of the results presented here are based on the simulation of a simple building (30 ft x 50 ft, four walls oriented north, south, east and west, four windows, flat roof, slab floor). The large cracks such as those around external doors are assumed to be sealed well, so that all infiltration occurs through smaller cracks or pores in the walls, roof, and around the window edges. Figure 1 is a diagram of airflow configurations through the walls and roof of this building. All of these configurations are modeled in annual simulations for this study, and their airflow configuration numbers will be used to reference them in the upcoming graphs and tables of the results. It should be noted that the "natural flow" airflow condition, included as configuration 4 in Figure 1, is an

approximation of natural air leakage, but it neglects the effects of outdoor wind speed and direction. Except for this "natural flow" configuration, the airflow arrangements in Figure 1 would all have to be generated artificially with a fan system in a real building. Note that some of the configurations include airflows into and out of the building, while others just have all airflows leaving or entering the building. The latter group of configurations requires only a fan system to pressurize or depressurize the building, causing air to exit or enter the building walls/roof, respectively, to satisfy the building air mass balance. The former group, however, requires a more complex fan system to cause different flows in different building wall surfaces. The more complex fan system often provides an increased heat transfer benefit – both the entering and leaving air flows through wall surfaces, so heat interaction occurs with both flows instead of just one (which is the case with a building pressurization fan).

The presentation of the simulation results will now proceed, beginning with the building simulations in the warm climate of Houston, TX. Table 1 shows the results of all of the year-long simulations run for this climate. Eight building wall airflow configurations were run for each of four building ACH values, giving 32 test runs to evaluate. The classical result, model result and annual load savings percentage columns represent the hourly algebraic summation of equations (4), (5) and (6), respectively, over a year for this building. The annual load savings with respect to natural flow column substitutes the natural flow  $Q_{\text{model,bldg}}$

result (airflow configuration 4) for  $Q_{\text{classical,bldg}}$  in equation (6). In most real buildings, average ACH is not near 0, and does not rise much above 2, so for a general evaluation of results, only the calculation runs where ACH = 0.3 and ACH = 1.0 will be included. Under this qualification, it can be seen in Table 1 that the largest value of energy load savings is about 17%, with both the opposite of natural flow and the optimization attempt airflow arrangements and ACH = 1.0. The same two airflow patterns produce the best results with respect to a natural flow condition, but the annual load savings in these cases drops to about 10%. Figure 2 shows the classical result and model result column data from Table 1 graphically. Because the magnitude of infiltration heat transfer is the same for all airflow configurations with a classical calculation, the classical result can be drawn as a straight line in this figure. The bars represent the model result, with the airflow configuration numbers corresponding to the numbers in Table 1. The configuration bar which is the shortest (or which shows the greatest distance from the classical result downward) represents the greatest energy savings with respect to the classical calculation. Though this figure is not designed to depict savings with respect to the natural flow case, it can be approximated by extending a straight line across the figure even with the bar level of airflow case 4 and comparing with that line.

Table 2 shows the same building analyses that were presented in Table 1 and Figure 2, but the results are separated into the components of

building cooling and heating load. Large savings values are reported in some sections of this table, but they can be misleading. For example, heating load savings of about 36% are produced by four of the airflow configurations for  $ACH = 1.0$ . However, this is a very warm climate, so such savings would not translate to large dollar savings. The largest cooling load savings value is a more realistic measure of the effectiveness of the interaction effect here; it is about 10%, and is produced by the all-exfiltration condition. The results of the simulations show that a natural flow condition produces efficient heat recovery in the heating season, so as expected, heating load savings with respect to natural flow in Table 2 are no higher than about 1%. Cooling load savings with respect to natural flow are higher at about 17% for the all-exfiltration condition. Again, these results are shown visually in Figure 3, with the best savings production represented by the largest gap between the model bar values and the classical result line.

The next set of tables and figures represents results from the same series of calculations that produced the tabular and graphical results just described, but the new calculations are made for the cooler climate of Seattle, WA. Again, the results included for discussion are limited to the cases where  $ACH = 0.3$  or  $1.0$ . In Table 3, it is shown that four airflow arrangements produce annual load savings of around 30%. When compared with natural flow, however, the largest load savings value is only 1.4%. These results are presented graphically in Figure 4. Based on these results, the effectiveness of natural flow

in creating wall heat recovery in cool weather appears to be very good.

Table 4 shows the results of the same calculations made for the Seattle climate, broken into cooling and heating loads, and Figure 5 shows these results visually. The largest heating load savings found were about the same as the total load savings reported in Table 3, at about 31% for the same four airflow configurations. The optimization attempt produces the best cooling load savings, at about 16%, but in this climate, with a small cooling load, these savings are insubstantial. When the calculation results are compared with natural flow, they are much less impressive than a comparison with a classical calculation. The best heating load savings performance is about 0%; this means the natural flow case is the best performer in this climate for heating savings. The cooling load savings with respect to natural flow are still good, at about 37% for the optimization attempt, but again this value is essentially meaningless. It does indicate, however, that in a climate where the cooling load is substantial, these other airflow arrangements could provide significant savings over the natural flow condition.

### Building Modifications

This study analyzes the heat transfer benefit provided when a building takes advantage of the interaction effect to save energy. A real building will likely require some changes to fully benefit from this effect, however. These changes would require investment costs as well as operational costs of

equipment such as fans which are needed to induce airflow through the building walls/roof in a given pattern. A cost analysis is not made for this study, but for a serious assessment of the benefits that are predicted here, at least an estimate of these building retrofit costs needs to be weighed against the economic savings that the heat transfer simulations run for this study indicate. Only then can the results of this study be used to provide a meaningful prediction of the net economic savings produced by the interaction effect in a building.

The most basic element required to create energy savings based on the interaction effect is a fan system which can be used to pressurize or depressurize a building, and/or individual rooms. If a building requires a retrofit in this regard, such a change could be as simple as a box fan placed and sealed in a window opening. Also, the building walls must not be sealed with a vapor barrier, or otherwise designed tightly. On the other hand, large cracks around doors, window seals, and such should be caulked or sealed to best take advantage of the interaction effect, because air flowing through larger cracks will not interact with wall material as well as it will through smaller cracks or pores. The idea is to create airflow through a building's wall surfaces, to allow wall air heat recovery and heat transfer to take place.

Some of the building wall/roof airflow patterns which are simulated for this study are rather complicated, as indicated in the results section earlier. The patterns call for flow out of some

walls and into others in a building at the same time. To generate this kind of airflow pattern, the individual rooms which border on exterior walls would have to be equipped with their own fan systems to pressurize or depressurize the rooms, creating a pressure drop which would induce airflow through the exterior wall (making the interior walls of the room well-sealed would make this airflow generation most efficient). A double wall design could also be employed to isolate the exterior wall to sectional fan-induced flows, but this would likely be too costly. A heat recovery device could even be installed with the pressurization fan(s) to make the overall system more efficient.

### Environmental Impact

There is a possible disadvantage to inducing air flows through the building materials in walls or roofs. Some indoor rooms might feel drafty if air flows in from outdoors. In addition, the flow of air through a building's walls or roof could cause condensation inside, outside or even within the walls or roof. McWatters [1995] includes a brief summary of a paper which notes the condensation issue, but concludes that opinions vary as to the significance of its effects in non-airtight building walls. Perhaps humidification/dehumidification of a building would alleviate these problems. It appears that studies on experimental test buildings will be needed to determine the environmental impact of allowing fresh air to flow through a building envelope.



## Conclusions and Future Recommendations

Significant building heat transfer benefits have been found for some conditions of climate and building wall airflow arrangement. Further study of this potential source of energy savings in buildings is warranted, especially in field testing some of the best performance conditions simulated for this report. The major findings, conclusions and recommendations of this study will now be summarized.

Perhaps the most significant finding of this theoretical study is that the changes needed to take advantage of the interaction effect may be warranted in a warm climate, but are probably not recommended in a cooler climate. This study has shown that the "natural flow" configuration, which is an approximation of the preexisting wall airflow condition in homes and some commercial buildings, provides wall heat recovery performance during cold weather as good as any other airflow configuration simulated for this study. Therefore, this study does not recommend that building changes to induce wall airflows be carried out in cool or cold climates. In a warm climate, this study has shown some promising results. Annual energy load savings of up to 17% and 10%, with respect to a classical and natural flow calculation, respectively, were found for the climate of Houston, TX. Such savings are significant enough to justify some changes in a building. The best results in this climate were produced by the opposite of natural flow optimization attempt, and sometimes

the all infiltration/exfiltration airflow arrangements; all of these patterns should be considered when evaluating possible building changes. The all infiltration/exfiltration airflow condition appears to be the most economically feasible of these retrofit options. Of course, further study is also needed to see how well these results translate to real buildings. Future experimental analysis is recommended to shed more light on how well the theoretical savings predicted with the interaction model compare to actual results, and how well retrofitted buildings perform and produce energy savings.

## References

- Anderlind, G. 1985. Energy Consumption Due to Air Infiltration. *Proceedings of the 3rd ASHRAE/DOE/BTECC Conference on Thermal Performance of Exterior Envelopes of Buildings*: 201-208. Clearwater Beach, FL, December.
- ASHRAE. 1993. *Fundamentals Handbook*. Atlanta, GA: American Society of Heating, Refrigerating and Air-Conditioning Engineers, Inc.
- Bailly, N. R. 1987. Dynamic Insulation Systems and Energy Conservation in Buildings. *ASHRAE Transactions* 93(1): 447-466.
- Dubois, P. 1983. Energy Efficient Building Walls. *Proceedings of the First EC Conference on Solar Collectors in Architecture*: 144-158. Venice, Italy, March 3-5.

Energy Information Administration. 1992. *Annual Energy Review 1991*. Washington, D.C.: Office of Energy Markets and End Use, U.S. Department of Energy.

Kohonen, R., and Virtanen, M. 1987. Thermal Coupling of Leakage Flows and Heating Load of Buildings. *ASHRAE Transactions* 93(2): 2303-2318.

Liu, M. 1992. Study of Air Infiltration Energy Consumption. Ph.D. Dissertation. College Station, TX: Texas A&M University.

Liu, M., and Claridge, D. 1992a. The Measured Energy Impact of Infiltration Under Dynamic Conditions. *Proceedings of the 8th Symposium on Improving Building Systems in Hot and Humid Climates*, Dallas, TX, May 13-14.

Liu, M., and Claridge, D. 1992b. The Measured Energy Impact of Infiltration in an Outdoor Test Cell. *Proceedings of the 8th Symposium on Improving Building Systems in Hot and Humid Climates*, Dallas, TX, May 13-14.

McWatters, K. 1995. A Prediction of Energy Savings Resulting from Building Infiltration Control. M.S. Thesis. College Station, TX: Texas A&M University.

*Typical Meteorological Year User's Manual* TD-9734. 1988. Asheville, NC: National Climatic Center.

Vaidya, S. 1993. The Measured Energy Impact of Air Leakage on a House. M.S. Thesis. College Station, TX: Texas A&M University.

Virtanen, M. 1991. Thermal Coupling of Leakage Airflows and Heating Load in Building Components and Buildings. *12th AIVC Conference: 87-102*. Ottawa, Canada, September 24-27.

Large arrows indicate airflow directed through a wall (or roof);  
small arrows indicate airflow directed through cracks around a window

Airflow patterns shown are for summer conditions: all airflow directions are reversed in winter in cases 1-4, and 7

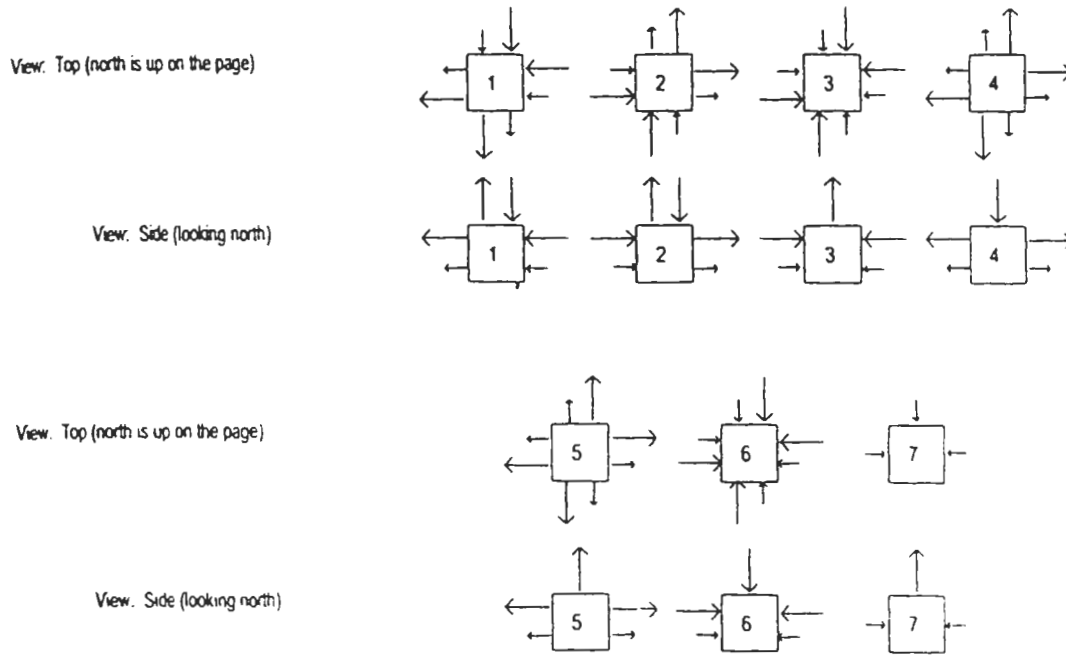

Building wall airflow configuration

Number	Description
1	Half in, half out (good case)
2	Half in, half out (worse case)
3	Opposite of natural flow
4	Natural flow
5	All exfiltration
6	All infiltration
7	Best optimization strategy

Figure 1. Computer heat transfer models of a building: direction of airflows through building walls (airflow configurations)

Table 1. Annual total energy loads and load savings results in Houston, TX

Building envelope airflow configuration number	Annual Total Energy Load [Wh]		Annual load savings percentage	Annual load savings w.r.t. natural flow	Unit wall massflow [ft/s] and ACH
	Classical result	Model result			
1	13769057.25	13769053.89	2.44E-05	4.87E-06	2E-09, 8.34E-07
2	13769057.25	13769053.89	2.44E-05	4.87E-06	2E-09, 8.34E-07
3	13769057.25	13769053.22	2.93E-05	9.73E-06	2E-09, 8.34E-07
4	13769057.25	13769054.56	1.95E-05	—	2E-09, 8.34E-07
5	13762924.47	13762921.96	1.82E-05	4.45E-02	1E-09, 8.34E-07
6	13761070.35	13761069.51	6.10E-06	5.80E-02	1E-09, 8.34E-07
7	13769057.25	13769052.89	3.17E-05	1.21E-05	2E-09, 8.34E-07
8	13762924.47	13762922.1	1.72E-05	4.45E-02	1E-09, 8.34E-07
1	15008952.3	13979522.02	6.86	1.62	0.0007194, 0.3
2	15008952.3	13982645.8	6.84	1.60	0.0007194, 0.3
3	15008952.31	13729632.83	8.52	3.38	0.0007194, 0.3
4	15008952.31	14210206.84	5.32	—	0.0007194, 0.3
5	15002568.23	14131950.56	5.80	0.55	0.0003597, 0.3
6	15000724.91	14727275.21	1.82	-3.64	0.0003597, 0.3
7	15008952.31	13651612.56	9.04	3.93	0.0007194, 0.3
8	15002568.23	14180381.76	5.48	0.21	0.0003597, 0.3
1	18091293.45	15934780.88	11.92	4.24	0.002398, 1.0
2	18091293.45	15946589.62	11.85	4.17	0.002398, 1.0
3	18091293.34	15054700.12	16.78	9.53	0.002398, 1.0
4	18091293.34	16640316.08	8.02	—	0.002398, 1.0
5	18084611.92	15504515.86	14.27	6.83	0.001199, 1.0
6	18082788.88	17435204.5	3.58	-4.78	0.001199, 1.0
7	18091293.34	15003640.76	17.07	9.84	0.002398, 1.0
8	18084611.92	15616578.84	13.65	6.15	0.001199, 1.0
1	33639973.23	33616386.27	0.07	7.90	0.01, 4.17
2	33639973.23	33755268.87	-0.34	7.52	0.01, 4.17
3	33639973.71	30298310.32	9.93	16.99	0.01, 4.17
4	33639973.71	36499249.31	-8.50	—	0.01, 4.17
5	33633827.91	28052277.51	16.60	23.14	0.005, 4.17
6	33632043.86	34818549.9	-3.53	4.60	0.005, 4.17
7	33639973.71	29326471.48	12.82	19.65	0.01, 4.17
8	33633827.91	27583669.91	17.99	24.43	0.005, 4.17
<b>Building envelope airflow configuration</b>					
<b>Number</b>	<b>Type</b>				
1	Infiltration in half the walls, exfiltration through the other half, best case				
2	Infiltration in half the walls, exfiltration through the other half, worse case				
3	Opposite of natural flow				
4	Natural flow				
5	All building exfiltration				
6	All building infiltration				
7	Optimization attempt				
8	All building infiltration or exfiltration, depending on winter or summer season				

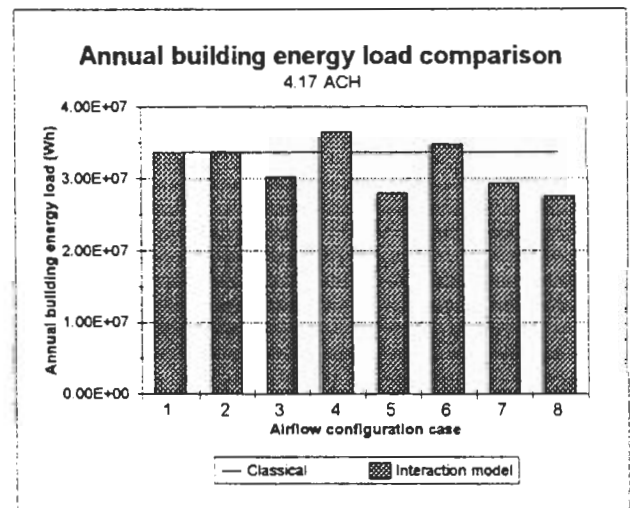
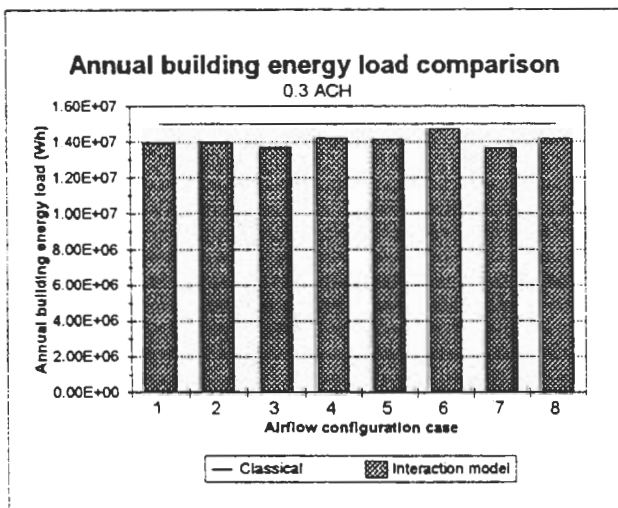
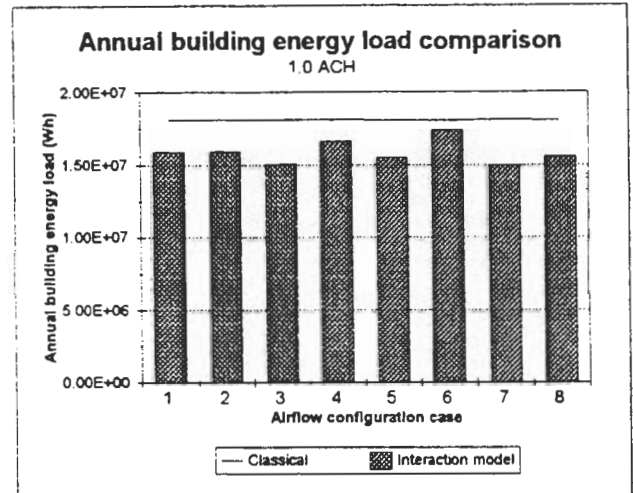
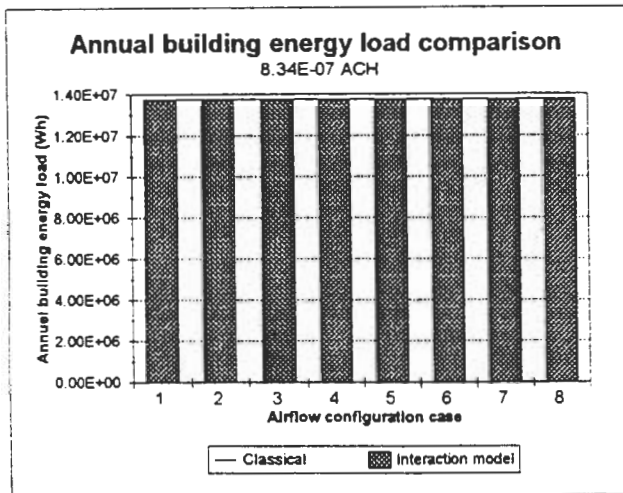

Figure 2. Annual total energy load results in Houston, TX for four ACH values

Table 2. Annual total heating and cooling loads and load savings results in Houston, TX

Building envelope airflow configuration number	Annual Total Energy Load [Wh]				Annual heat load savings	Annual cool load savings	Ann. heat load savings w.r.t. natural flow	Ann. cool load savings w.r.t. natural flow	Unit wall massflow [ft/s] and ACH
	Classical result		Model result						
	Heating	Cooling	Heating	Cooling					
1	3178621	10590436	3178619	10590435	8.87E-05	5.19E-06	2.52E-07	6.61E-06	2E-09, 8.34E-07
2	3178621	10590436	3178619	10590435	8.87E-05	5.19E-06	1.89E-07	6.61E-06	2E-09, 8.34E-07
3	3178621	10590436	3178619	10590435	8.89E-05	1.18E-05	4.40E-07	1.32E-05	2E-09, 8.34E-07
4	3178621	10590436	3178619	10590436	8.85E-05	-1.4E-06	—	—	2E-09, 8.34E-07
5	3178621	10584303	3178620	10584302	4.31E-05	1.11E-05	-4.54E-05	5.79E-02	1E-09, 8.34E-07
6	3178621	10582449	3178620	10582450	4.56E-05	-6.1E-06	-4.28E-05	7.54E-02	1E-09, 8.34E-07
7	3178621	10590436	3178619	10590434	9.08E-05	1.37E-05	2.33E-06	1.51E-05	2E-09, 8.34E-07
8	3178621	10584303	3178620	10584302	4.56E-05	8.22E-06	-4.28E-05	5.79E-02	1E-09, 8.34E-07
1	4215817	10793136	3291023	10688499	21.94	0.97	-0.02	2.12	0.0007194, 0.3
2	4215817	10793136	3291761	10690885	21.92	0.95	-0.04	2.10	0.0007194, 0.3
3	4215817	10793136	3285128	10444505	22.08	3.23	0.16	4.35	0.0007194, 0.3
4	4215817	10793136	3290506	10919701	21.95	-1.17	—	—	0.0007194, 0.3
5	4215817	10786751	3737871	10394080	11.34	3.64	-13.60	4.81	0.0003597, 0.3
6	4215817	10784908	3704764	11022511	12.12	-2.20	-12.59	-0.94	0.0003597, 0.3
7	4215817	10793136	3311114	10340499	21.46	4.19	-0.63	5.30	0.0007194, 0.3
8	4215817	10786751	3704763	10475618	12.12	2.88	-12.59	4.07	0.0003597, 0.3
1	6774718	11316575	4344192	11590589	35.88	-2.42	-0.35	5.85	0.002398, 1.0
2	6774718	11316575	4347955	11598635	35.82	-2.49	-0.43	5.79	0.002398, 1.0
3	6774718	11316575	4308223	10746477	36.41	5.04	0.48	12.71	0.002398, 1.0
4	6774718	11316575	4329196	12311120	36.10	-8.79	—	—	0.002398, 1.0
5	6774718	11309894	5341786	10162730	21.15	10.14	-23.39	17.45	0.001199, 1.0
6	6774718	11308071	5185226	12249978	23.46	-8.33	-19.77	0.50	0.001199, 1.0
7	6774718	11316575	4653449	10350192	31.31	8.54	-7.49	15.93	0.002398, 1.0
8	6774718	11309894	5185225	10431354	23.46	7.77	-19.77	15.27	0.001199, 1.0
1	19461796	14178177	14366614	19249772	26.18	-35.77	1.13	12.38	0.01, 4.17
2	19461796	14178177	14473701	19281568	25.63	-35.99	0.39	12.23	0.01, 4.17
3	19461797	14178177	14273355	16024956	26.66	-13.03	1.77	27.06	0.01, 4.17
4	19461797	14178177	14530490	21968760	25.34	-54.95	—	—	0.01, 4.17
5	19461797	14172031	16327718	11724560	16.10	17.27	-12.37	46.63	0.005, 4.17
6	19461797	14170247	14818816	19999734	23.86	-41.14	-1.98	8.96	0.005, 4.17
7	19461797	14178177	15562770	13763702	20.03	2.92	-7.10	37.35	0.01, 4.17
8	19461797	14172031	14818811	12764859	23.86	9.93	-1.98	41.90	0.005, 4.17
Building envelope airflow configuration									
Number	Type								
1	Infiltration in half the walls, exfiltration through the other half, best case								
2	Infiltration in half the walls, exfiltration through the other half, worse case								
3	Opposite of natural flow								
4	Natural flow								
5	All building exfiltration								
6	All building infiltration								
7	Optimization attempt								
8	All building infiltration or exfiltration, depending on winter or summer season								

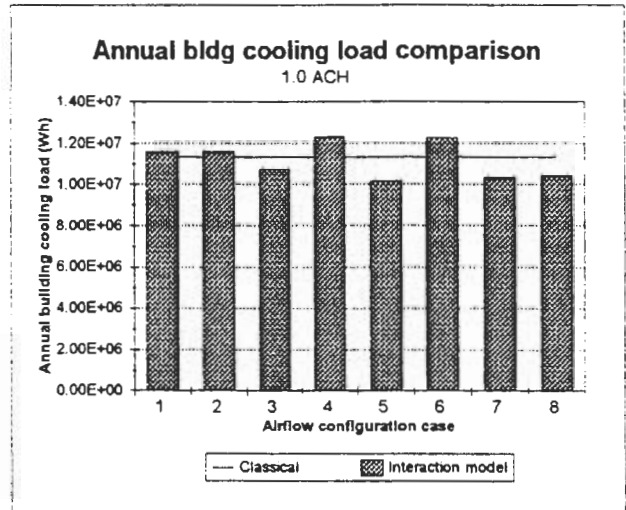
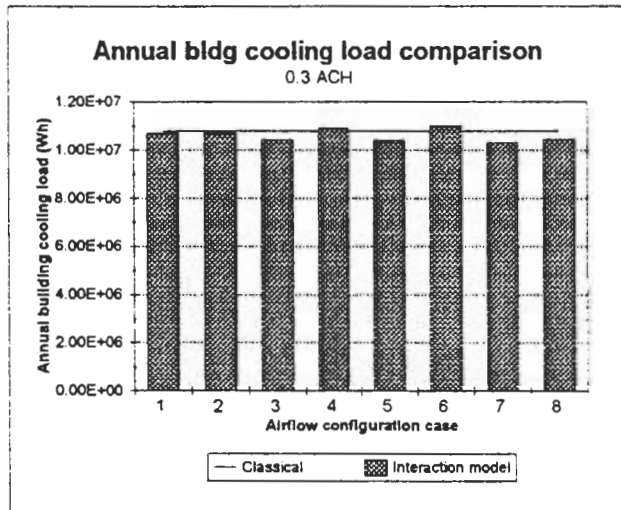
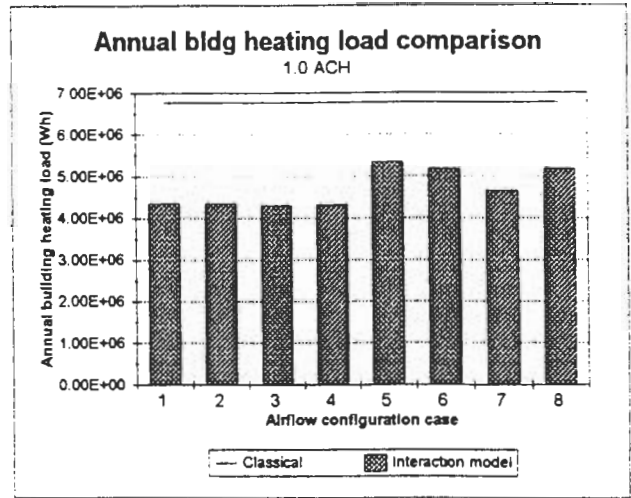
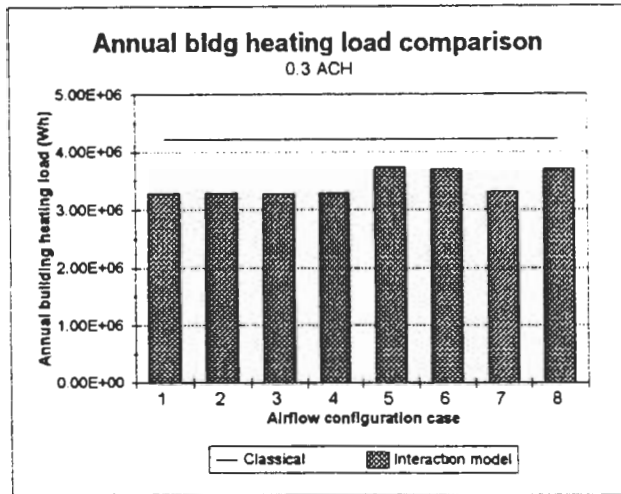

Figure 3. Annual total heating and cooling loads in Houston, TX for ACH = 0.3 and 1.0

Table 3. Annual total energy loads and load savings results in Seattle, WA

Building envelope airflow configuration number	Annual Total Energy Load [Wh]		Annual load savings percentage	Annual load savings w.r.t. natural flow	Unit wall massflow [ft/s] and ACH
	Classical result	Model result			
1	16225210.26	16225199.53	6.61E-05	1.17E-06	2E-09, 8.34E-07
2	16225210.26	16225199.65	6.54E-05	4.31E-07	2E-09, 8.34E-07
3	16225210.26	16225199.47	6.65E-05	1.54E-06	2E-09, 8.34E-07
4	16225210.26	16225199.72	6.50E-05	—	2E-09, 8.34E-07
5	16223674.92	16223669.63	3.26E-05	9.43E-03	1E-09, 8.34E-07
6	16223766.78	16223761.39	3.32E-05	8.86E-03	1E-09, 8.34E-07
7	16225210.26	16225199.32	6.74E-05	2.47E-06	2E-09, 8.34E-07
8	16223674.92	16223669.41	3.40E-05	9.43E-03	1E-09, 8.34E-07
1	20108282.14	16638563.22	17.26	0.33	0.0007194, 0.3
2	20108282.14	16681468.93	17.04	0.07	0.0007194, 0.3
3	20108282.18	16600990.74	17.44	0.55	0.0007194, 0.3
4	20108282.18	16693078.12	16.98	—	0.0007194, 0.3
5	20106991.07	18297737.79	9.00	-9.61	0.0003597, 0.3
6	20107380.32	18240247.84	9.29	-9.27	0.0003597, 0.3
7	20108282.18	16726949.1	16.82	-0.20	0.0007194, 0.3
8	20106991.07	18205747.98	9.46	-9.06	0.0003597, 0.3
1	29391251.22	20597464.43	29.92	0.62	0.002398, 1.0
2	29391251.22	20747341.66	29.41	-0.10	0.002398, 1.0
3	29391250.91	20433531.15	30.48	1.41	0.002398, 1.0
4	29391250.91	20726539.42	29.48	—	0.002398, 1.0
5	29390882.37	24143100.27	17.86	-16.48	0.001199, 1.0
6	29391561.59	23809116.13	18.99	-14.87	0.001199, 1.0
7	29391250.91	21814291.91	25.78	-5.25	0.002398, 1.0
8	29390882.37	23776175.91	19.10	-14.71	0.001199, 1.0
1	72787593.53	56912480.39	21.81	1.47	0.01, 4.17
2	72787593.53	57604250.65	20.86	0.27	0.01, 4.17
3	72787594.81	56819806.81	21.94	1.63	0.01, 4.17
4	72787594.81	57762287.25	20.64	—	0.01, 4.17
5	72789964.84	61511096.65	15.50	-6.49	0.005, 4.17
6	72790070.74	58780990.93	19.25	-1.76	0.005, 4.17
7	72787594.81	62301520.24	14.41	-7.86	0.01, 4.17
8	72789964.84	59650427.55	18.05	-3.27	0.005, 4.17
<b>Building envelope airflow configuration</b>					
<b>Number</b>	<b>Type</b>				
1	Infiltration in half the walls, exfiltration through the other half, best case				
2	Infiltration in half the walls, exfiltration through the other half, worse case				
3	Opposite of natural flow				
4	Natural flow				
5	All building exfiltration				
6	All building infiltration				
7	Optimization attempt				
8	All building infiltration or exfiltration, depending on winter or summer season				



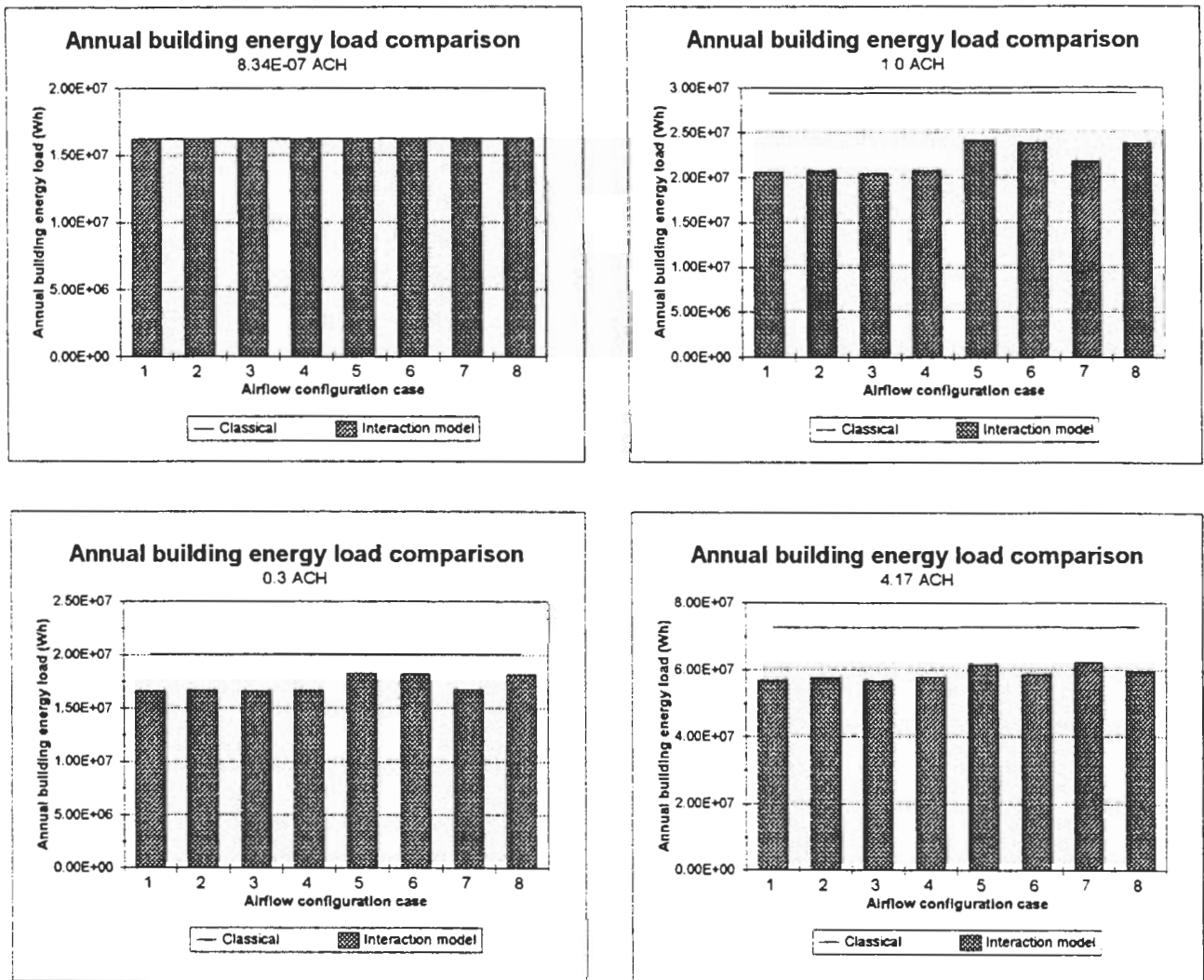

Figure 4. Annual total energy load results in Seattle, WA for four ACH values

Table 4. Annual total heating and cooling loads and load savings results in Seattle, WA

Building envelope airflow configuration number	Annual Total Energy Load [Wh]				Annual heat load savings	Annual cool load savings	Ann. heat load savings w.r.t. natural flow	Ann. cool load savings w.r.t. natural flow	Unit wall massflow [ft/s] and ACH
	Classical result		Model result						
	Heating	Cooling	Heating	Cooling					
1	15365709	859500.8	15365699	859500.8	6.99E-05	-9.3E-07	1.95E-07	1.84E-05	2E-09, 8.34E-07
2	15365709	859500.8	15365699	859500.9	6.94E-05	-5.6E-06	-3.25E-07	1.37E-05	2E-09, 8.34E-07
3	15365709	859500.8	15365699	859500.7	6.96E-05	1.29E-05	-1.30E-07	3.22E-05	2E-09, 8.34E-07
4	15365709	859500.8	15365699	859501	6.97E-05	-1.9E-05	—	—	2E-09, 8.34E-07
5	15364174	859500.8	15364169	859500.7	3.36E-05	1.38E-05	9.96E-03	3.32E-05	1E-09, 8.34E-07
6	15364266	859500.8	15364260	859501	3.60E-05	-1.7E-05	9.36E-03	2.21E-06	1E-09, 8.34E-07
7	15365709	859500.8	15365699	859500.7	7.02E-05	1.94E-05	4.56E-07	3.87E-05	2E-09, 8.34E-07
8	15364174	859500.8	15364169	859500.7	3.51E-05	1.38E-05	9.96E-03	3.32E-05	1E-09, 8.34E-07
1	19257310	850972.6	15775550	863012.7	18.08	-1.41	-0.01	6.07	0.0007194, 0.3
2	19257310	850972.6	15804155	877313.5	17.93	-3.10	-0.19	4.52	0.0007194, 0.3
3	19257310	850972.6	15781630	819361.1	18.05	3.71	-0.05	10.82	0.0007194, 0.3
4	19257310	850972.6	15774268	918810	18.09	-7.97	—	—	0.0007194, 0.3
5	19256019	850972.6	17487668	810069.9	9.18	4.81	-10.86	11.83	0.0003597, 0.3
6	19256408	850972.6	17334984	905263.7	9.98	-6.38	-9.89	1.47	0.0003597, 0.3
7	19257310	850972.6	15930177	796772	17.28	6.37	-0.99	13.28	0.0007194, 0.3
8	19256019	850972.6	17395678	810069.9	9.66	4.81	-10.28	11.83	0.0003597, 0.3
1	28550092	841159.6	19654694	942770.5	31.16	-12.08	-0.25	15.88	0.002398, 1.0
2	28550092	841159.6	19756640	990701.2	30.80	-17.78	-0.77	11.60	0.002398, 1.0
3	28550091	841159.7	19640184	793346.7	31.21	5.68	-0.18	29.21	0.002398, 1.0
4	28550091	841159.7	19605860	1120680	31.33	-33.23	—	—	0.002398, 1.0
5	28549723	841159.7	23421202	721898.4	17.96	14.18	-19.46	35.58	0.001199, 1.0
6	28550402	841159.7	22775029	1034088	20.23	-22.94	-16.16	7.73	0.001199, 1.0
7	28550091	841159.7	21107339	706953	26.07	15.95	-7.66	36.92	0.002398, 1.0
8	28549723	841159.7	23054278	721898.4	19.25	14.18	-17.59	35.58	0.001199, 1.0
1	71916772	870822	55268355	1644125	23.15	-88.80	0.32	29.01	0.01, 4.17
2	71916772	870822	55769478	1834773	22.45	-110.69	-0.58	20.77	0.01, 4.17
3	71916773	870822	55737014	1082793	22.50	-24.34	-0.52	53.24	0.01, 4.17
4	71916773	870822	55446427	2315860	22.90	-165.94	—	—	0.01, 4.17
5	71919143	870822	60871560	639536.9	15.36	26.56	-9.78	72.38	0.005, 4.17
6	71919249	870822	56949232	1831759	20.82	-110.35	-2.71	20.90	0.005, 4.17
7	71916773	870822	61602091	699428.8	14.34	19.68	-11.10	69.80	0.01, 4.17
8	71919143	870822	59010891	639536.9	17.95	26.56	-6.43	72.38	0.005, 4.17
Building envelope airflow configuration									
Number	Type								
1	Infiltration in half the walls, exfiltration through the other half, best case								
2	Infiltration in half the walls, exfiltration through the other half, worse case								
3	Opposite of natural flow								
4	Natural flow								
5	All building exfiltration								
6	All building infiltration								
7	Optimization attempt								
8	All building infiltration or exfiltration, depending on winter or summer season								

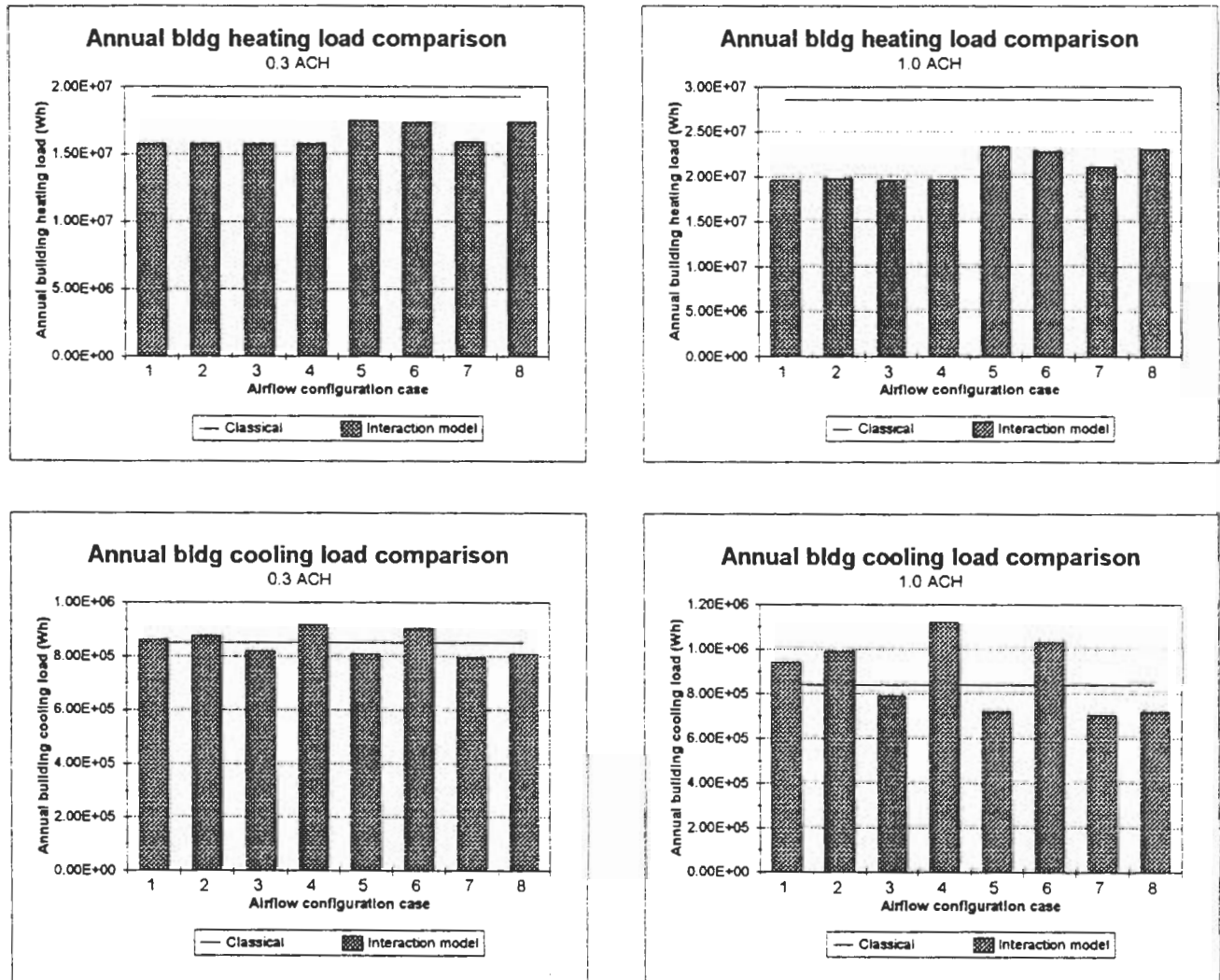

Figure 5. Annual total heating and cooling loads in Seattle, WA for ACH = 0.3 and 1.0