

Study on Control Performance of HVAC System of Interior Zone and Perimeter Zone in Office Building -Estimation of Optimal PI Tuning in Cooling Operation-

Katsuki Maehara
Doctoral Candidate

Noriyasu Sagara
Professor

The University of Kitakyushu
Kitakyushu, Japan

Abstract: In office buildings there are generally two HVAC systems installed, one in the perimeter zone (PZ) and one in the interior zone (IZ), and the temperatures of each zone are independently controlled. In the present paper, in order to solve the problem of not being able to satisfy the requirements of room temperature control during the cooling period in summer, an optimal PID parameter (O-PI) is selected through simulation of its two feedback control systems with mutual influence using the models identified with the experimental data. The step response characteristics of the system with optimal parameters compared to those with the parameters selected by the Ziegler-Nichols Method (ZNM-PI) that are generally used for PID parameter tuning on site.

The result shows O-PI improved control performance, and the difference between O-PI and ZNM-PI can be used to readjust ZNM-PI selected on site.

INTRODUCTION

In office buildings, different HVAC systems are usually adopted in the perimeter zone (PZ) and interior zone (IZ), mainly due to the different heat loads and independently controlled temperature. Heating and cooling are needed in the PZ and the IZ, respectively, and the mixture of the air in these two zones can increase heating and cooling energy consumptions. In summer, unsatisfactory performance may originate in the temperature control. Since the two control systems of the PZ and the IZ influence each other, on-site

adjustment of the control parameters is difficult. To solve such problems, the present paper proposes an optimal parameter tuning process in the cooling operation, as follows:

1. Monitoring the unsatisfactory phenomena in an experiment during the operation of the fan-coil unit (FCU) for the PZ and AHU for the IZ.
2. Identifying^{[1][2]} the VWV control system for the FCU and VAV control system for the AHU.^[3]
3. Choosing the optimal parameters through simulations by using the models which is based on the identification.^[4]
4. Verifying the control performance of the experimental HVAC system that is operated with its optimal values estimated through the simulation.
5. Comparing the control performance of the experimental HVAC system by using the control parameters obtained by means of the Ziegler-Nichols Method.

OBJECTIVE SYSTEM

The University of Kitakyushu's HVAC system performance testing apparatus (HSPTA)^{[5]-[6]} is shown in Fig. 1 and Fig. 2, a $6.0 \times 10.0 \times 2.7$ [m] testing room (TR) having a floor area of 60 square meters. The TR is surrounded by six rooms called guard rooms (GRs), the temperatures of which can be artificially maintained between 5 and 35 [deg. C]. The TR is thus equivalent to the occupancy space of a general middle floor office. The TR is separated from

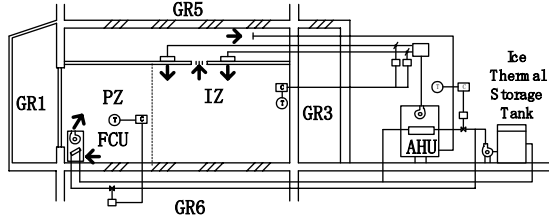

Fig.1. Schematic diagram

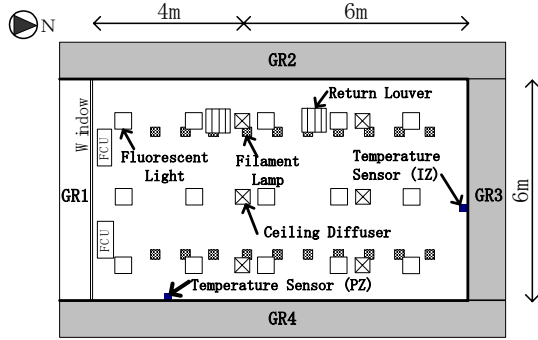

Fig.2. Ceiling plan

a guard room (GR1) on the south side by two double sliding windows. GR1 is used as a pseudo-outdoor space, and is separated from the outdoor air by double-glazing. The temperatures of GR2 through GR4 surrounding the TR are maintained at the same temperature as the TR. The zone 4 [m] away from the south side of the TR is called the perimeter zone (PZ), and the zone located 4 [m] away from the PZ is called the interior zone (IZ).

The cold air supplied through the diffusers at the ceiling board to the TR flows to the ceiling plenum through the openings in the ceiling board and returns to the AHU through the return openings in the ceiling plenum.

Figure 3 shows a block diagram of the two feedback loops to control the temperatures in both the PZ and IZ. The PZ temperature is controlled by a two-way valve to regulate water flow through the FCU (VWV control system) and the IZ temperature is controlled by a VAV system that regulates the supply air volume by the damper (VAV control system). The outlet air temperature of the AHU is kept constant by a two-way valve to regulate the chilled water flow rate through

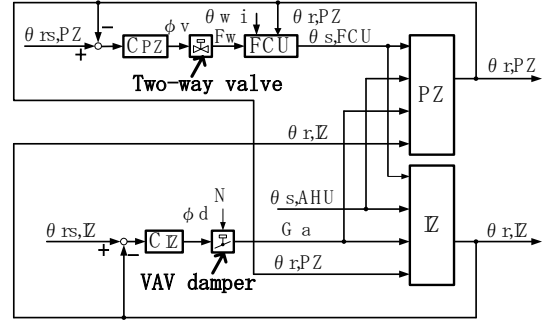

Fig.3. Control system block diagram of HSPTA

- $\theta_{rs,PZ}$: PZ room temperature set point [deg. C]
- $\theta_{rs,IZ}$: IZ room temperature set point [deg. C]
- $\theta_{r,PZ}$: PZ room temperature [deg. C]
- $\theta_{r,IZ}$: IZ room temperature [deg. C]
- $\theta_{s,FCU}$: FCU supply air temperature [deg. C]
- $\theta_{s,AHU}$: AHU supply air temperature [deg. C]
- θ_{wi} : FCU water temperature of chilled water coil inlet [deg. C]
- ϕ_v : FCU two-way valve position [%]
- ϕ_d : VAV damper position [%]
- N : AHU fan inverter output control signal [%]
- G_a : AHU supply airflow rate [m³/h]
- F_w : FCU chilled water flow rate [L/min]
- C_{PZ} : PID controller of PZ
- C_{IZ} : PID controller of IZ

the AHU cooling coil. Equation 1 is a computing equation for the PID controller. In this case, $T_d = 0$ and only the values of PB and T_i are optimally selected.

$$MV = \frac{100}{PB} \left(PV + \frac{1}{Ti \cdot s} E + \frac{Td \cdot s}{1 + (Td/md) \cdot s} PV \right) \quad (1)$$

where

- MV : manipulated [%] (ϕ_v, ϕ_d),
- PV : measured value [%] ($\theta_{r,PZ}, \theta_{r,IZ}$),
- SV : set point [%] ($\theta_{rs,PZ}, \theta_{rs,IZ}$),
- E : error [%] ($E = PS - SV$),
- md : deferential gain (md fixed 0),
- PB : proportional band [%],
- T_i : integral time [%],
- T_d : differential time [s], and
- s : operator.

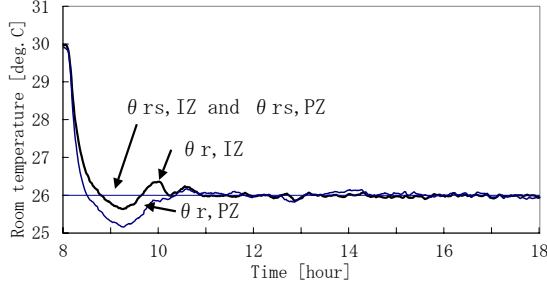

Fig.4. Room temperature of PZ and IZ

EXPERIMENTAL OUTLINE AND RESULTS

The experiment was performed at a temperature of 26 [deg. C] in both the PZ and IZ. The control parameters for the FCU system are tentatively selected as $PB_{PZ} = 100$ [%] and $Ti_{PZ} = 100$ [s]. The control parameters for the VAV system are also tentatively adopted as $PB_{IZ} = 2$ [%] and $Ti_{IZ} = 1,000$ [s].^{[6]-[7]} These values are referred to later herein as tentative values (T-PI). The operating time is 10 hours, from 8:00 to 18:00, and the temperature of the GR1 is controlled in a daily periodic steady state operation to the hourly outside air temperature for the design of the HVAC system in Fukuoka, Japan.

The data are analyzed in a periodic steady state condition that occurs approximately one week after the beginning of the experiment. Figure 4 shows the temperature fluctuations for the PZ and IZ. They can reach and then overshoot each set point, and the errors between the measured and set point temperatures of PZ and IZ are approximately 1 [K] and 0.5 [K], respectively. These errors result in an unsatisfactory thermal environment.

IDENTIFICATION AND MODELING OF THE HVAC CONTROL SYSTEM

1. Modeling of the PZ and IZ

The PZ and IZ are identified using the data of the experiment (Ex-A) with the sampling time of one minute. The dynamic models of the IZ and the PZ were identified as the ARX model with four input

Table 1. Input and output variables of PZ and IZ models

Input of PZ model	Input of PZ model
$\theta_{s,FCU}$: FCU supply air temperature	$\theta_{s,FCU}$: FCU supply air temperature
$\theta_{s,AHU}$: AHU supply air temperature	$\theta_{s,AHU}$: AHU supply air temperature
Ga: AHU supply aifflow rate	Ga: AHU supply aifflow rate
$\theta_{r,IZ}$: IZ room temperature	$\theta_{r,IZ}$: IZ room temperature
Output or PZ model	Output or PZ model
$\theta_{r,PZ}$: PZ room temperature	$\theta_{r,PZ}$: PZ room temperature

variables and one output variable. These input and output variables are shown in Table 1. The orders of a denominator polynomial n_a and the orders of a numerator polynomial n_b are determined as 2, and the delay from the input time to output time m is determined as 0. The identified models of the PZ and the IZ are shown in Equations 2 through 19.

$$A(q)y(t) = B(q)u(t) + e(t) \quad (2)$$

$$A(q) = 1 + a_1q^{-1} + \dots + a_{n_a}q^{-n_a} \quad (3)$$

$$B(q) = q^{-m}(b_0 + b_1q^{-1} + \dots + b_{n_b}q^{-n_b}) \quad (4)$$

$$q^{-1}u(t) = u(t-1) \quad (5)$$

where

$y(t)$: output signal,

$u(t)$: input signal,

$e(t)$: disturbance,

t : time,

n_a : orders of a denominator polynomial,

$n_a = n$, where n is the orders of model,

n_b : orders of a numerator polynomial,

$n_b = n$ when $m=0$, $n_b = n-1$ when $m \geq 1$,

m : delays from input to output time, and

q^{-1} : shift operator.

The model of PZ is as follows:

$$y(t) = \Delta\theta_{r,PZ}(t) \quad (6)$$

$$A(q) = 1 - 1.39q^{-1} + 4.28 \times 10^{-1}q^{-2} \quad (7)$$

$$u_{PZ}(q)^T = [\Delta\theta_{s,FCU}, \Delta\theta_{s,AHU}, \Delta G_a, \Delta\theta_{r,IZ}] \quad (8)$$

where $\Delta X = X - \bar{X}$, and \bar{X} is the average of X .

$$B_{\Delta\theta_{s,FCU}}(q) = -1.05 \times 10^{-2} + 3.71 \times 10^{-2}q^{-1} - 2.27 \times 10^{-2}q^{-2} \quad (9)$$

$$B_{\Delta\theta_{s,AHU}}(q) = -3.93 \times 10^{-4} + 3.31 \times 10^{-3}q^{-1} - 9.99 \times 10^{-4}q^{-2} \quad (10)$$

$$B_{\Delta G_a}(q) = -2.53 \times 10^{-5} + 3.52 \times 10^{-5}q^{-1} - 2.21 \times 10^{-5}q^{-2} \quad (11)$$

$$B_{\Delta\theta_{r,IZ}}(q) = 3.00 \times 10^{-1} - 2.77 \times 10^{-1}q^{-1} - 1.70 \times 10^{-3}q^{-2} \quad (12)$$

The model of the IZ is as follows:

$$y(t) = \Delta\theta_{r,IZ}(t) \quad (13)$$

$$u_{IZ}(t)^T = [\Delta\theta_{s,FCU}, \Delta\theta_{s,AHU}, \Delta G_a, \Delta\theta_{r,PZ}] \quad (14)$$

$$A(q) = 1 - 1.33q^{-1} + 3.52 \times 10^{-1} q^{-2} \quad (15)$$

$$B_{\Delta\theta_{s,FCU}}(q) = -1.44 \times 10^{-3} + 7.74 \times 10^{-3} q^{-1} - 8.76 \times 10^{-3} q^{-2} \quad (16)$$

$$B_{\Delta\theta_{s,AHU}}(q) = -6.28 \times 10^{-3} + 9.80 \times 10^{-3} q^{-1} - 5.11 \times 10^{-3} q^{-2} \quad (17)$$

$$B_{\Delta G_a}(q) = -1.62 \times 10^{-4} + 1.81 \times 10^{-4} q^{-1} - 9.56 \times 10^{-6} q^{-2} \quad (18)$$

$$B_{\Delta\theta_{r,IZ}}(q) = 2.25 \times 10^{-1} - 1.30 \times 10^{-1} q^{-1} - 8.72 \times 10^{-2} q^{-2} \quad (19)$$

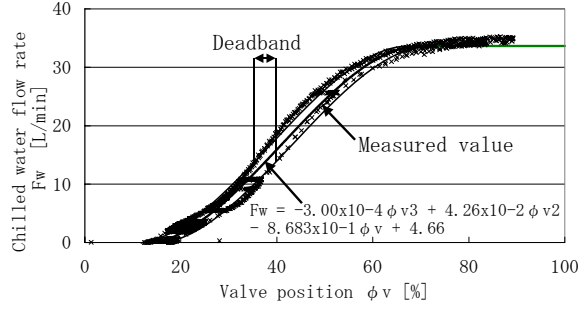

Fig.5. Relationship between two-way valve position ϕ_v and chilled water flow rate F_w

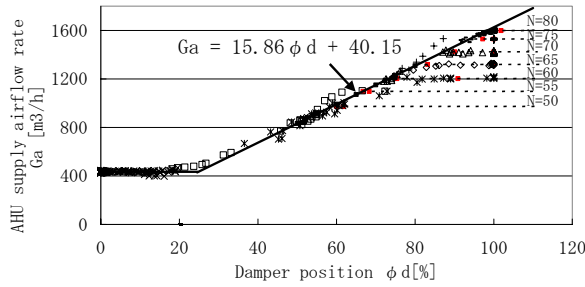

Fig.6. Relationship between VAV damper position ϕ_d and supply airflow rate G_a

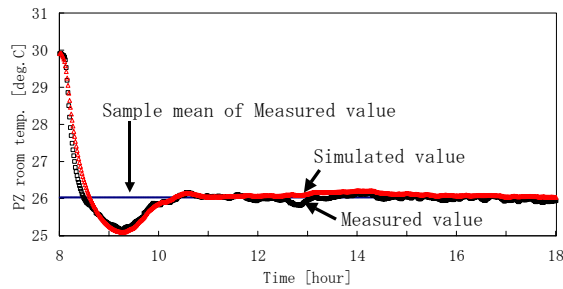

Fig.7. Measured and simulated perimeter zone temperature $\theta_{r,PZ}$

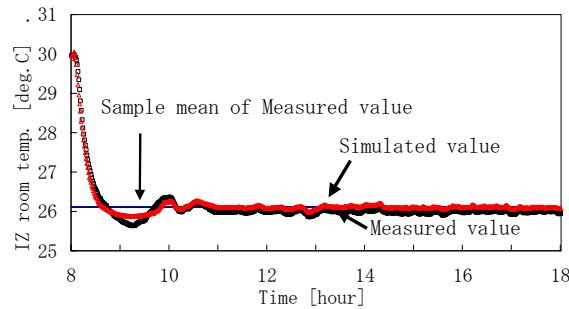

Fig.8. Measured and simulated interior zone room temperatures $\theta_{r,IZ}$

2. Identification of the fan coil unit and two-way valve

Figure 5 shows a scatter plot of the relationship between the two-way valve for the FCU position (ϕ_v) and the chilled water flow rate (F_w), which is expressed as a third-degree regression equation with the predictor as illustrated in Equation 20. This relationship has the characteristics of backlash with a dead band for the valve opening of 5.4 [%]. The lower value of the water flow rate is 0 [l/min] and the upper value is 35.5 [l/min].

$$F_w = 3.00 \times 10^{-4} \phi_v^3 + 4.26 \times 10^{-2} \phi_v^2 - 8.68 \times 10^{-1} \phi_v + 4.66 \quad (20)$$

3. Identification of the damper

Figure 6 shows a scatter plot of the relationship between the damper position (ϕ_d) and the airflow rate (G_a), which is expressed as a linear regression equation with the predictor as the signal shown in Equation 21. This relationship has the characteristics of a backlash of 0.8 [%], and the upper value of the supply airflow rate (G_{ah}) with the AHU fan speed is expressed in Equation 22.

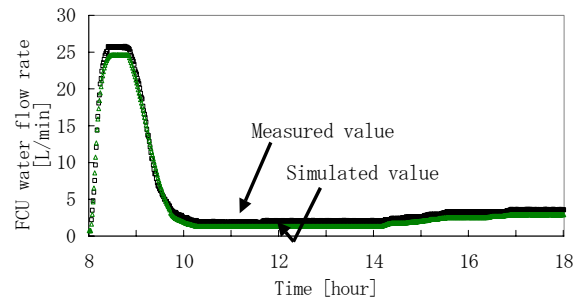

Fig.9 Measured and simulated FCU chilled water flow rate F_w

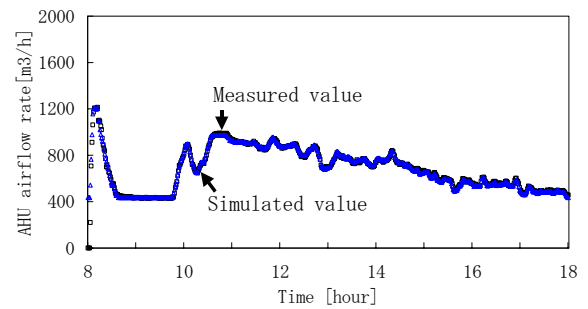

Fig.10 Measured and simulated AHU supply airflow rate G_a

$$G_a = 15.9\phi_d + 40.2 \quad (21)$$

$$G_{ah} = 21.2N - 71.2 \quad (22)$$

4. Verification of the component models

The outputs simulated by inputting EX-A data into the above component models are shown in Figs. 7 to 10. In each component model, the simulated outputs can fit the measurements of EX-A with a sufficient degree of accuracy.

PID TUNING THROUGH SIMULATION

The responses of the PZ and IZ room temperatures to the simultaneous step inputs of -0.1 [K] of the PZ and IZ set points were obtained through the simulation^[8] for two feedback control systems with mutual influence, as shown in Fig. 3. An optimal PI parameter is selected to minimize the evaluation indexes (Equation 23 or 24) among the simulation cases that adopt different sets of PI parameters.

$$J_P = E_{PZ} + E_{IZ}, \text{ for P tuning} \quad (23)$$

$$J_{PI} = E_{PZ} + E_{IZ}, \text{ for PI tuning} \quad (24)$$

$$E_{PZ} = \frac{1}{P} \sum_{i=1}^P \varepsilon_{PZ}^2(i) \quad (25)$$

$$E_{IZ} = \frac{1}{P} \sum_{i=1}^P \varepsilon_{IZ}^2(i) \quad (26)$$

$$\varepsilon_{PZ}(i) = \theta_{r,PZ}(i) - u_{s,PZ}(i) \quad (27)$$

$$\varepsilon_{IZ}(i) = \theta_{r,IZ}(i) - u_{s,IZ}(i) \quad (28)$$

where

u_s : step input,

i : time,

p : the number of sampling data.

1. Proportional (P) tuning with response to step change for the set points

Figure 11 shows the values of the evaluation indexes only with different P parameters and with the Ti value fixed at 0 [%]. This figure shows E_{PZ} and E_{IZ} for every set of PB_{PZ} and PB_{IZ} , the range of which is 2 to 8 [%] and 2 to 4 [%], respectively. E_{PZ} and E_{IZ} are minimal in the case of $PB_{PZ} = 4$ [%] and $PB_{IZ} = 2$ [%].

Figures 12 and 13 show the step responses of the PZ and IZ room temperatures for the case in which the values of E_{PZ} and E_{IZ} are smaller. With both PB_{PZ} and PB_{IZ} set to 2 [%], the temperatures in the PZ and IZ overshoot the set point of -0.1 [K]. The offsets for the PZ and IZ room temperatures have an insufficient tracking performance with only P-control.

The evaluation index J_P is shown in Table 2. From these results, $PB_{PZ} = 4$ [%] and $PB_{IZ} = 2$ [%] as

Table 2. Evaluation indexes of P tuning

PB [%]	① E_{PZ}	② E_{IZ}	J_P (①+②)
PB _{PZ} =2; PB _{IZ} =2	0.266	0.522	0.789
PB _{PZ} =2; PB _{IZ} =4	0.329	0.626	0.955
PB _{PZ} =4; PB _{IZ} =2	0.160	0.358	0.518
PB _{PZ} =4; PB _{IZ} =4	0.201	0.458	0.659
PB _{PZ} =6; PB _{IZ} =2	0.215	0.468	0.683
PB _{PZ} =6; PB _{IZ} =4	0.331	0.629	0.960
PB _{PZ} =8; PB _{IZ} =2	0.296	0.532	0.829
PB _{PZ} =8; PB _{IZ} =4	0.458	0.727	1.185

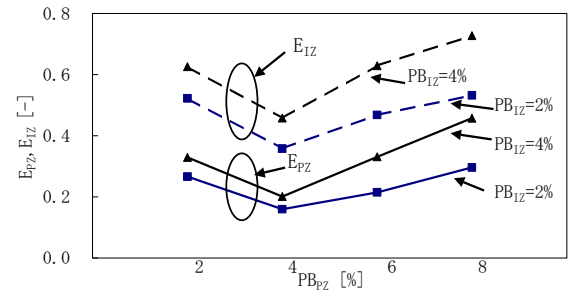

Fig.11. E_{PZ} and E_{IZ} with P tuning

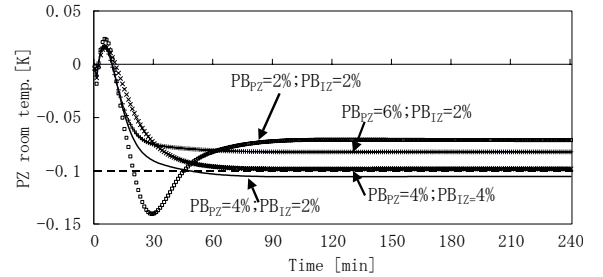

Fig.12. Step responses of perimeter zone temperature $\theta_{r,PZ}$ with P tuning

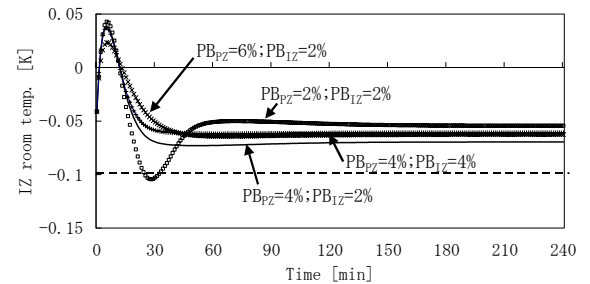

Fig.13. Step responses of interior zone temperature $\theta_{r,IZ}$ with P tuning

optimal values with only P-control, are selected.

2. A step response to step input for a set point with Proportional-Integral (PI)-control

Figure 14 shows the values of evaluation indexes with different I parameters, with PB fixed at the abovementioned values and Td value fixed at 0 [%]. This figure shows E_{PZ} and E_{IZ} with every set of Ti_{PZ} and Ti_{IZ} , in the range of 1,000 to 4,000 [s], respectively.

Tab.3. Evaluation indexes of PI tuning

Ti [s]	① E_{PZ}	② E_{IZ}	J_{PI} (① + ②)
$Ti_{PZ}=1000$; $Ti_{IZ}=1000$	0.289	0.280	0.569
$Ti_{PZ}=1000$; $Ti_{IZ}=2000$	0.243	0.267	0.511
$Ti_{PZ}=1000$; $Ti_{IZ}=4000$	0.222	0.324	0.546
$Ti_{PZ}=2000$; $Ti_{IZ}=2000$	0.252	0.253	0.505
$Ti_{PZ}=2000$; $Ti_{IZ}=4000$	0.225	0.305	0.530
$Ti_{PZ}=4000$; $Ti_{IZ}=2000$	0.301	0.246	0.547
$Ti_{PZ}=8000$; $Ti_{IZ}=2000$	0.386	0.242	0.628

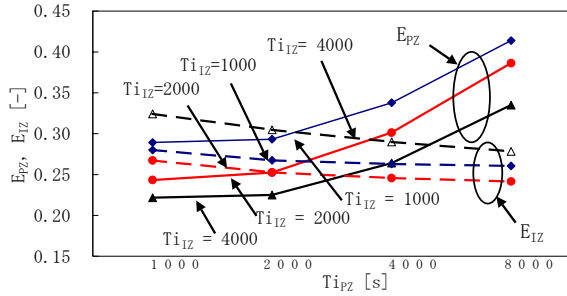

Fig.14. E_{PZ} and E_{IZ} with PI tuning

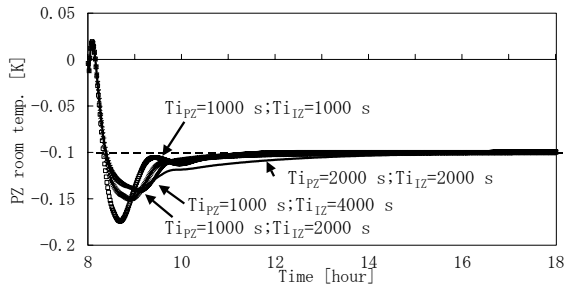

Fig.15. Step responses of perimeter zone temperature $\theta_{r,PZ}$ with PI tuning

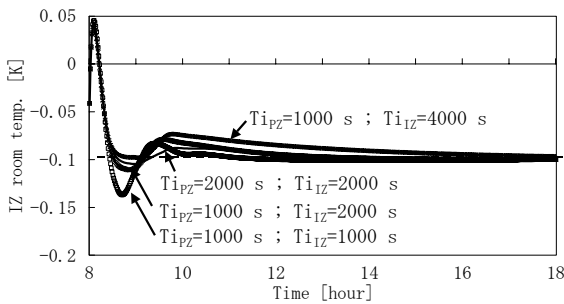

Fig.16. Step responses of interior zone temperature $\theta_{r,IZ}$ with PI tuning

With the increment of Ti_{PZ} , E_{IZ} is decreased but E_{PZ} is decreased. Figures 15 and 16 show the step responses of the PZ and IZ room temperature in the case of the sets of Ti values with fewer values in evaluation indexes.

The responses of the PZ temperature overshoot in every case, and then gradually reach the set point of -0.1 [K]. The larger Ti_{IZ} can avoid the overshoot of responses of the IZ temperature. Table 3 shows the set of $Ti_{PZ} = 2,000$ [s] and $Ti_{IZ} = 2,000$ [s] that minimize the evaluation indexes J_{PI} . Therefore, we select the set of $PB_{PZ} = 4$ [%], $Ti_{PZ} = 2,000$ [s], $PB_{IZ} = 2$ [%], and $Ti_{IZ} = 2,000$ [s], as an optimal PI parameter (O-PI).

VERIFICATION OF THE VALIDITY OF THE O-PI THROUGH EXPERIMENT

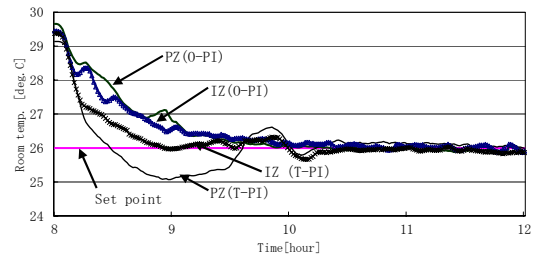

Fig.17. Measurements of $\theta_{r,PZ}$ and $\theta_{r,IZ}$ with T-PI and O-PI

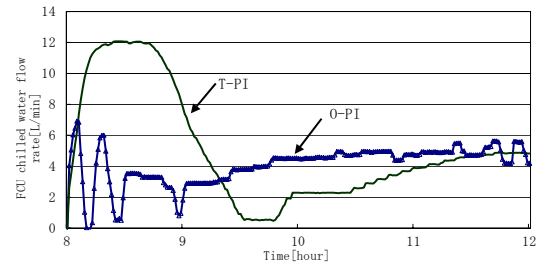

Fig.18. Measurements of FCU chilled water flow F_w with T-PI and O-PI

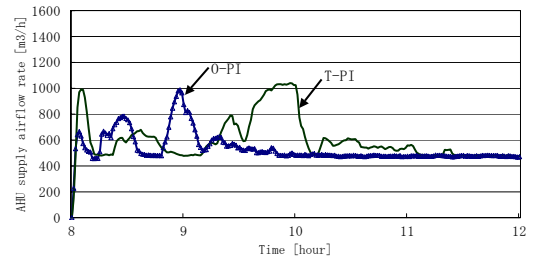

Fig.19. Measurements of AHU supply airflow G_a with T-PI and O-PI

The control performance is confirmed to be fully satisfactory in the verification experiment with O-PI adopted for the actual system of the HSPTA. Figures 17 through 19 show the measurements of the PZ and IZ room temperatures, and the chilled water flow rate of the FCU and the supply air volume of the AHU. Figure 17 shows that both the temperatures of the PZ

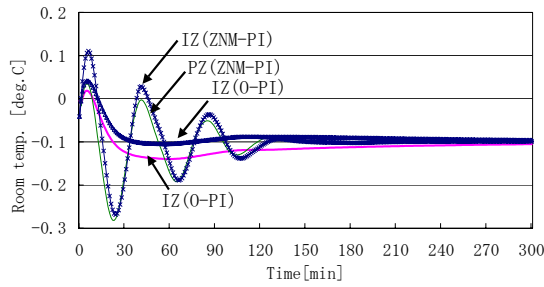

Fig.20. Responses of $\theta_{r,PZ}$ and $\theta_{r,IZ}$ with O-PI and ZNM-PI to simultaneous step changes of $-0.1[K]$ in set point for two feedback control systems [Case 1]

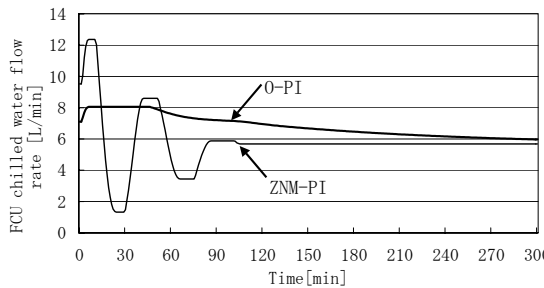

Fig.21. Responses of FCU water flow rate F_w with O-PI and ZNM-PI [Case 1]

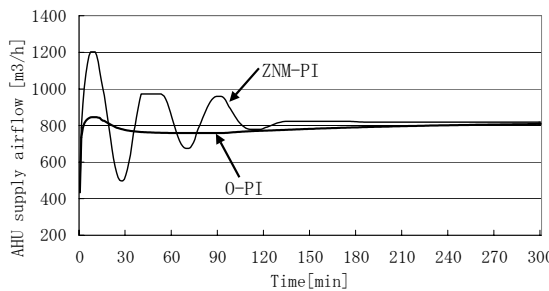

Fig.22. Responses of AHU supply airflow rate G_a with O-PI and ZNM-PI [Case 1]

and IZ with O-PI gradually reach the set points without overshoot, so the control performance is improved compared to that of the case of the tentative values of PI. Figure 18 indicates that the operation with O-PI parameters reduces the large consumption of the chilled water flow rate of the FCU in approximately an hour after the beginning of air-conditioning.

COMPARISON OF THE O-PI TUNING AND THE TUNING BY THE ZIEGLER-NICHOLS METHOD

The Ultimate Sensitivity Method by the Ziegler-Nichols method^[9] (ZNM) is generally used for the adjustment of the PID parameter on site. Comparing the step response characteristics of the system with the PI parameters (ZNM-PI) selected by the ZNM with those with O-PI for discussing the methods of PI parameter tuning on site. The PI parameters are estimated through the following procedure using the Ziegler-Nichols method for two feedback control systems with mutual influence. First, each T-PI is temporarily adopted as the parameters for each system. The PI parameters are then tuned by the application of the ZNM to one feedback system with the PI parameters of another system maintained at its own T-PI. The same tuning procedure is conducted for each feedback control system, and the PI parameters (ZNM-PI) of both the VWV system and the VAV system are tuned.

Evaluation indexes J_s for each step response of the system with O-PI and ZNM-PI through simulation is shown in Table 4. Case 1 shows the responses to simultaneous step changes of $-0.1 [K]$ in set point for two feedback control systems, and case 2 shows the

Tab.4. Evaluation indexes with O-PI and ZNM-PI

	PZ		IZ		Case 1			Case 2			Case 3		
	PB _{PZ}	Ti _{PZ}	PB _{IZ}	Ti _{IZ}	E _{PZ}	E _{IZ}	J _{PI}	E _{PZ}	E _{IZ}	J _{PI}	E _{PZ}	E _{IZ}	J _{PI}
O-PI	4	2000	2	2000	0.262	0.256	0.518	0.382	0.1338	0.516	0.761	0.411	1.173
ZNM-PI	2	2000	1	1000	0.673	0.904	1.577	0.318	0.2093	0.527	0.727	0.467	1.194

response to the same step change in set point for only the VVW system with the FCU, and case 3 shows that for only the VAV system with the AHU. Figures 20 through 22 show the step responses of the PZ and IZ room temperatures, the chilled water flow rate of the FCU (Fw), and the supply air volume of the AHU (Ga) in case 1. The PZ and IZ room temperatures with ZNM-PI oscillate due to the fluctuations of Fw and Ga, while they change stably with O-PI. Since the evaluation indexes Js of O-PI are smaller than those of ZNM-PI, O-PI is the better control parameter.

Figures 23 and 24 show the step responses of the PZ and IZ room temperatures for case 2 and case 3. The response of one room temperature to the step change in its set point influences the temperature of the other room as a disturbance. In each case, the responses with ZNM-PI oscillate more sensitively than those with O-PI. The evaluation indexes Js of O-PI are slightly smaller, i.e., are better than those of ZNM-PI.

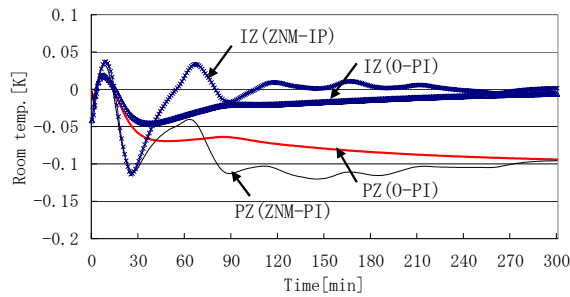

Fig.23. Responses of $\theta_{r,PZ}$ and $\theta_{r,IZ}$ with O-PI and ZNM-PI to step change of $-0.1[K]$ in set point of perimeter zone temperature: Case 2

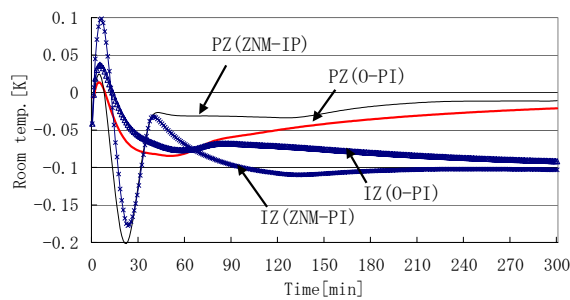

Fig.24. Responses of $\theta_{r,PZ}$ and $\theta_{r,IZ}$ with O-PI and ZNM-PI to step change of $-0.1[K]$ in set point of interior zone temperature: Case 3

Therefore, O-PI is a better control parameter, especially for case 1.

O-PI selected through simulation for two feedback control systems with mutual influence improved the problem of overshoot in actual operation of the HSPTA. Since the performance of O-PI is better than that of ZNM-PI, the difference between O-PI and ZNM-PI can be used to readjust the selected ZNM-PI relatively easily on site.

CONCLUSIONS

In general office buildings, two HVAC systems are usually used in perimeter and interior zones to control the room temperature of each zone based on their different heat load characteristics. To solve a problem in the above-described system, such as the inability to satisfy each setting value during the cooling period in the summer, we selected an optimal PID parameter through simulation with mutual influence for two feedback control systems. The conclusions are summarized as follows:

1. The dynamic models of the IZ and PZ were identified using the system identification method. The optimal PI parameters (O-PI) for the two identified HVAC control systems were estimated to be $PB_{PZ} = 4$ [%], $Ti_{PZ} = 2,000$ [s], $PB_{IZ} = 2$ [%], and $Ti_{IZ} = 2,000$ [s] through simulation using evaluation indexes Js.
2. O-PI was adapted to the actual system of the HSPTA, and the control performance was confirmed experimentally to be satisfactory.
3. The system performance with O-PI is compared to that with the parameters estimated by the Ziegler-Nichols method, which is generally used for the on-site adjustment of a PID parameter. The difference can be used to readjust the selected ZNM-PI.

ACKNOWLEDGMENTS

The authors would like to thank Yan SU, a graduate

student of the University of Kitakyushu, Lianming SUN, a professor of the University of Kitakyushu, and Kazunori KUNIHURO, SHINKAWA Electric Corp., for their valuable support.

REFERENCES

- [1] Gene F. FRANKLIN et al., 1998, "Digital Control of Dynamic Systems", 3rd ed., Addison Wesley, Menlo Park, CA.
- [2] L. LJUNG, 1995, "System Identification Toolbox - For Use with MATLAB" 3rd ed., The MATH WORKS Inc., Natick, MA.
- [3] Noriyasu SAGARA, Yan SU, Katsuki MAEHARA, Shinji KANADA, 2007. "Study on the Control Performance of Two HVAC Systems for an Office Space - Part 3. Identification of Thermal Characteristics of Perimeter Zone and Interior Zone -" Summaries of Technical Papers of the Annual Meeting, Architectural Institute of Japan, Environmental Engineering 2, August, 2007, Fukuoka, Japan. (In Japanese)
- [4] Shinji KANADA, Yan SU, Katsuki MAEHARA, Noriyasu SAGARA, 2007. "Study on the Control Performance of Two HVAC Systems for an Office Space - Part 4. Estimation of Optimal Tuning of PI parameters by simulation-" Summaries of Technical Papers of the Annual Meeting, Architectural Institute of Japan, Environmental Engineering 2, August, 2007, Fukuoka, Japan. (In Japanese)
- [5] Noriyasu SAGARA, Yuji RYU, Akihito OZAKI, Weijun GAO, Yasuyuki SHIRAIISHI, 2002. "The Outline of The HVAC System Performance Testing Apparatus of The University of Kitakyushu" Summaries of Technical Papers of the Annual Meeting, Architectural Institute of Japan, Environmental Engineering 2, pp.1209-1210, August, 2002, Hokuriku, Japan. (In Japanese)
- [6] Katsuki MAEHARA, Noriyasu SAGARA, Sung-ki SONG, 2006, "The Optimization of Control Parameters for a VAV HVAC System Commissioning" Maximizing Building Energy Efficiency and Comfort (Part 2), Vol.4-1-4, Nov, 2006, ICEBO 2006 Proceedings, Shenzhen, China.
- [7] Katsuki MAEHARA, Noriyasu SAGARA, Sung-ki SONG, 2006, "The Optimization of Control Parameters for a VAV HVAC System Commissioning - An identification of Components and Settings of Control Parameters for a Chilled Water Coils Outlet Air Temperature and Room Temperature in a Cooling Mode" J. Environ. Eng., AIJ, No.603, pp.63-70, May, 2006, Architectural Institute of Japan, Tokyo, Japan. (In Japanese)
- [8] "SIMULINK-Dynamic System Simulation for MATLAB-Using Simulink Ver.4, 2000" The MATH WORKS Inc, Natick, MA.
- [9] Gene F. FRANKLIN et al., 2002, "Feedback Control of Dynamic System" 4th ed., Prentice-Hall, Inc., Upper Saddle River, NJ.