

## USING BUILDING CONTROL SYSTEM FOR COMMISSIONING

Hossein Vaezi-Nejad\*, Timothy I. Salisbury\*\*, Daniel Choiniere\*\*\*

\* *Centre Scientifique et Technique du Bâtiment, Paris, France.*

\*\* *Johnson Controls Inc., USA*

\*\*\* *Ressources Naturelles Canada - Natural Resources Canada*

**Summary.** This paper summarizes the different approaches developed during Annex 40 (research project of International Energy Agency - Energy Conservation in Buildings & Community Systems ) for carrying out commissioning activities using the control system. During our work we have found that control systems in buildings have the potential to greatly improve the commissioning process. In particular, control systems can be used to carry out automated testing on the energy systems in a building in a systematic way. Technologies for carrying out automated commissioning are still in their infancy and very few tools are available for practitioners to use. However, our work has demonstrated that tools can be built using existing infrastructure at relatively low cost. In many cases, tools are software programs that can be implemented on most microprocessor-based platforms.

Keywords: automated commissioning, Building control system, model-based method, rule-based method, performance index-based method

### INTRODUCTION

Today, microprocessor-based control systems are used to automatically operate many of the major energy systems in buildings. As technology continues to evolve, the trend is for more systems to come under the action of automatic control and for disparate systems to be integrated across communication networks. Automatic control systems eliminate the need for dedicated manual operators and can reduce costs. Modern control systems also allow the operation of multiple energy systems to be coordinated according to advanced building-level strategies. The proliferation of automation in buildings has led to a situation in which realizable building performance is fundamentally dependent on the control system. An important part of [commissioning](#) should therefore be to ensure that the control system is operating properly.

Control systems are becoming more modular and, from a commissioning perspective, modularization helps move some of the onus of testing onto the factory and component vendor. A valid expectation is therefore for components, whether hardware or software, to have been tested before arriving at a building for installation. The most important aspects to then verify and commission on-site will be those that have been affected by the installation process.

In addition to commissioning the control system itself, the control system can also be used as a tool for carrying out commissioning on the energy systems. A control system can serve as a commissioning tool by making use of its ability to manipulate energy systems through interfaces such as actuators and switches.

This paper summarizes the different approaches developed during Annex 40 for carrying out commissioning activities using the control system. The paper is organized as follows:

- o [Methods to CX the control system and Energy systems](#): describes methods that use the control system for commissioning.
- o [Implementation of Automated Commissioning Tools](#): discusses ways to implement commissioning tools and highlights practical issues
- o [Tools tested during the Annex](#): summarizes the tools that have been developed by Annex 40 participants.
- o [Conclusions](#).

### METHODS TO CX THE CONTROL SYSTEM AND ENERGY SYSTEMS

The methods described in this section have been developed and tested by interfacing to the control system through the controller workstation or higher-level supervisory controllers. However, because the methods mostly reside in software programs, they could, in principle, be implemented in any microprocessor-based device with sufficient resources that is connected to the control system network. The methods developed during the Annex project have also been tested mainly during the building operations phase.

#### Types of Commissioning Tests

Two approaches to commissioning using the control system that have been considered in Annex 40 are passive testing and active testing. Passive tests involve using the control system to monitor and record sensor and actuator signals from energy systems operating under normal conditions. These tests are non-invasive in that they do not introduce any artificial disturbances into the systems. The most important aspects of passive testing are to properly select points to monitor and to apply appropriate data analysis methods. Active testing involves making artificial changes to the systems under control in order to interrogate behavior. Active tests can reveal more information about a controlled system in a shorter time period than passive tests, but can be more expensive to implement.

#### Criteria for deciding between active & passive testing

A detailed analysis of the different approaches to commissioning is given in the Annex 40 Report that will be published in 2005. The document identifies that the commissioning phase, level of tool automation, tool location, communication capabilities between the control system and other platform, data monitoring type, knowledge of the users, detail of detection, impact on building occupant (disturbance during test) and commissioning budget are the main factors that influence the selection of the appropriate approach. Table 1 summarizes the selection criteria.

**Table 1: Passive/Active test decision criteria**

	<b>Passive Testing</b>	<b>Active testing</b>
Commissioning phase	On-going	Initial, re and retro
Level of automation of the tool	Manual to automatic	Manual to automatic
Tool location	Stand Alone, embedded	Stand alone
BEMS communication with other platform	Read	Write – Read
Data Monitoring	Long term monitoring	Short term monitoring
Knowledge of the users	Medium	High
Impact on the building operation	None	High
Commissioning Budget	Low	High

**Example of Methods**

Various types of methods have been considered in Annex 40, including: model-based, expert rules, graph technology, functional test sequences, and performance index. Some of the methods were also evaluated as part of IEA Annexes 25 and 34 [3]. This section describes the different approaches using examples based on tools developed during Annex 40.

**Model based**

The model-based method involves comparing predictions of a model with the measured performance of a component or system, as illustrated in Figure 1 (left). Significant differences indicate the presence of one or more faults. Figure 1 (right) shows the specific case of a heating coil. The inputs to the model are the measured inlet air and water temperatures and the control signal. A model of the coil, valve and actuator predicts the outlet air temperature, which is then compared to the measured value.

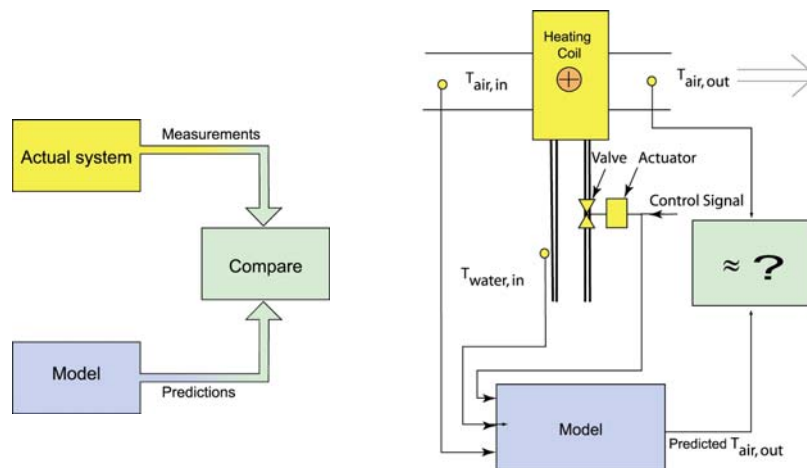

Figure 1: The concept of model-based fault detection and its application to a heating coil

**Rule-Based**

A rule-based method is based on the transcription of physical and logical prior (expert) knowledge of a system into a set of rules, e.g., IF/THEN. The rules should duplicate the same reasoning that an expert would use. A rule-based method for commissioning was developed by the USA & French teams and is described in [3]. The method comprises three main steps and these are described below.

1. Define the operating mode of the AHU by using control signal information. For an AHU we have defined different operating modes: Heating, Free Cooling, Mechanical Cooling with minimum outside air, Mechanical Cooling with 100% outside air, stop of the ventilation, frost protection.
2. Apply rules according to the specific mode. The rules are based on 3 main types of fault:
  - Incoherence between two measured values for a specific mode (example  $T^{\circ}\text{supply air} > T^{\circ}\text{mix air}$  in heating mode)
  - Incoherence between measurements in case of redundancy (example  $T^{\circ}\text{supply air} \neq T^{\circ}\text{mix air}$  in Free Cooling mode)
  - Incoherence between setpoint and its measured value (example  $T^{\circ}\text{supply air} > T^{\circ}\text{setpoint supply air}$ )

Example of application of the table of incoherence between two measured values for heating mode (Toa: outside air temperature, Tsa: supply air temperature, Tma: mix air temperature)

Heating Mode	Toa	Tsa	Tma	Tra
Toa		$Toa > Tsa$	$Toa > Tma$	$Toa > Tra$
Tsa			$Tsa < Tma$	?
Tma				$Tma > Tra$
Tra				

3. Define the diagnostic adapted to the violated rule. Example diagnostics are presented below.

Heating Mode	Toa	Tsa	Tma	Tra
Toa		- Sensor fault : Tsa or Toa - Cooling Coil valve leakage	- Sensor fault : Tma or Toa	- Sensor fault : Tra or Toa
Tsa			- Sensor fault : Tsa or Tma - Cooling Coil valve leakage	?
Tma				- Sensor fault : Tra or Tma
Tra				

**Performance index-based method**

Performance indices are calculated values or control values that quantify the performance of a control loop, component, or system. The performance index-based method applied to real time commissioning involves comparing indices of similar controllers or components under specific conditions (outside air temperature, humidity, etc) or under a specific period (instantaneous, one hour, one week), as illustrated in Figure 2. Performance index values can be normally distributed. Limits can be set to define a range of values corresponding to acceptable behavior and values that lie outside the range can indicate that a problem exists. Performance index values can also be used to optimize set points and improve system performance. Limits can be manually set or be estimated continuously. Performance indices can be analyzed by expert rules aided by control values and parameters to diagnose faults.

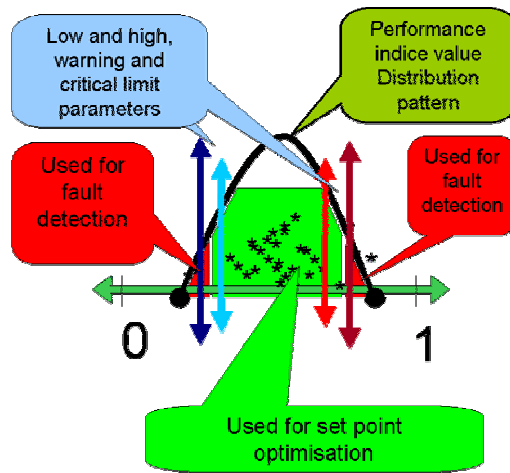

Figure 2: The concept of performance index-based method

**Logic Tracer**

The Japanese group developed a tool for checking the operation of control logic. The tool focuses on sequences of operation and is called the Control Logic Tracer (CLT). The tool allows control algorithms to be visualized via a graphic tool such as Microsoft Visio™. The CLT reads operational data in XML format and displays the control sequence as a diagram using trace colored lines. The main features of the CLT are listed below:

- Provides designers and operation managers with easy-to-understand information about HVAC control logic.
- Allows them to visualize how HVAC control sequences occur over time.
- Diagnoses failures by tracking down the causes traceable to the system control to correct operations when operation or control in a HVAC system fails.

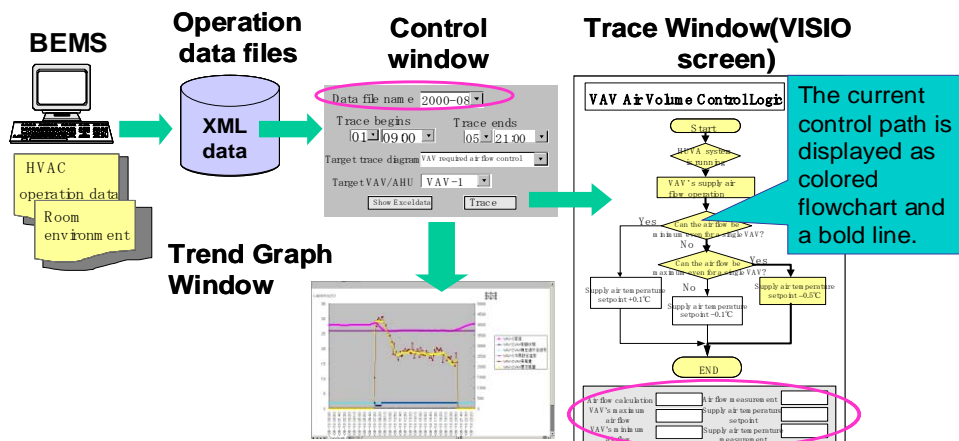

Figure 3: General configuration of HVAC Control Logic Tracer

**IMPLEMENTATION OF AUTOMATED COMMISSIONING TOOLS**

A commissioning tool can be implemented in the control system or in a separate hardware device such as a laptop computer that would be temporarily attached to the control system. The main elements of a commissioning tool include architecture, level of interface to the control system, method used, data management, data communication and user interface.

**Architecture Types**

As shown on Figure 4, building systems consist of HVAC components that are organized in subsystems (HVAC groups). Every HVAC unit includes a number of sensors. Each sensor has a unique address and provides data to a control Panel or central control network. The control panel can include other information describing the building system. Information from the control panel can be stored in a general database that could be used by different building optimization software such as an FDD tool, an automatic commissioning tool, or a trending tool.

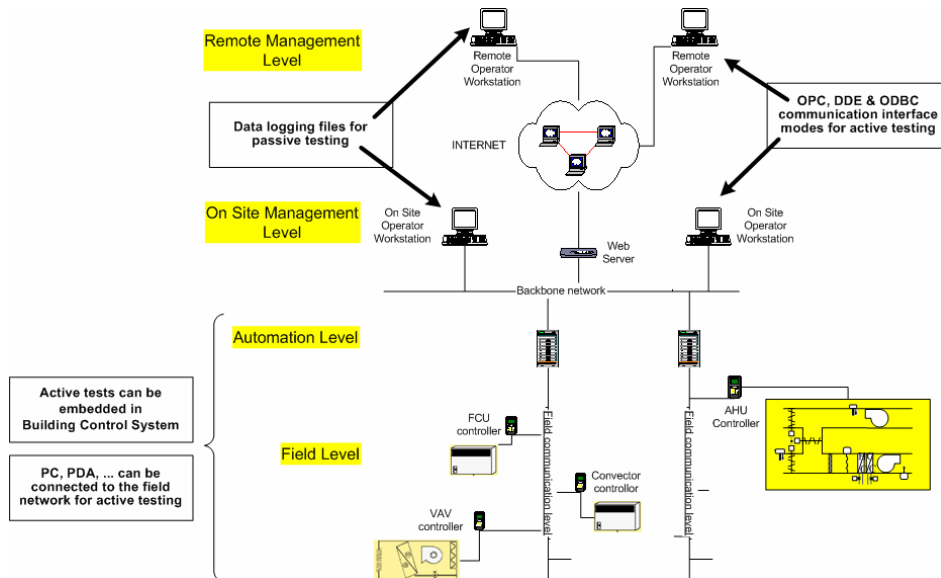

Figure 4: Architecture and communication protocols

A commissioning tool would usually be embedded in the control system or connected to it in order to use existing measurement and communication equipment in a building and reduce cost and time for commissioning tasks. When connected, the tool could reside on the operation workstation or could be in a remote site.

**Table 2: Types of architecture**

Tool Architecture	Location	Communication
Stand alone	Remote Management Level, Remote operator workstation	Via Internet or phone network
Stand Alone	On site Management Level On site operator workstation	Via Local Area Network
Stand alone or Embeded	Automation level Local Controllers & outstations	Automation communication level or Additional Instrument connected to the backbone network (LAN)
Stand alone or Embeded	Field level Terminal & room Controllers	Field communication level Additional or Instrument connected to the field network

**Communication Issues**

A practical barrier to the adoption of commissioning tools is the difficult of setting up communications between the tool and the control devices. From a tool developer’s standpoint, control systems that use open protocols can greatly simplify the implementation.

As part of Annex 40, the US National Institute of Standards and Technology (NIST) developed a commissioning test shell that establishes communication links with a control system using the BACnet communication protocol [4]. The test shell can actively override control system commands to invoke functional tests using a scripting capability.

**Database**

A database is a central component of a commissioning tool that can have a direct impact on tool performance. Databases can include a knowledge base used by the tool, commissioning models, performance test libraries, internal tool relationships, building and HVAC system configuration data, commissioning parameters (design data, sequences of operation, internal tool, etc.), operating control values, and finally the commissioning results. For an on-going commissioning tool, the database should have the capacity to store data for many months and years. In Annex 40, most of the tools that were developed use relational database such as a SQL server.

User Interface Examples

DABO Diagnostic & Cite-AHU Tools

Figure 5 through Figure 6 show example user interfaces for a commissioning tool developed by the Canadian team (Figure 5) and the French-US teams (Figure 6). The interface allows entry of system configuration data and the invoking of various fault detection modes. It also facilitates data communication and management between the building control system, database and commissioning module, as well as generating reports and getting online help. To be effective, an interface should be: reliable, easy to use, and easy to engineer, maintain, configure and understand. It should allow good interactivity with the user and be visually well designed.

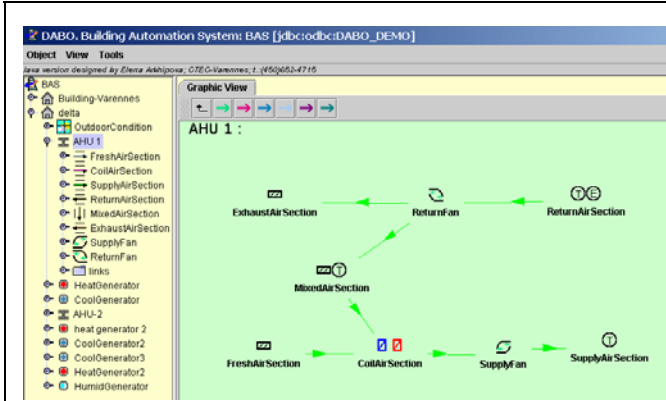

Figure 5: DABO-AHU configuration

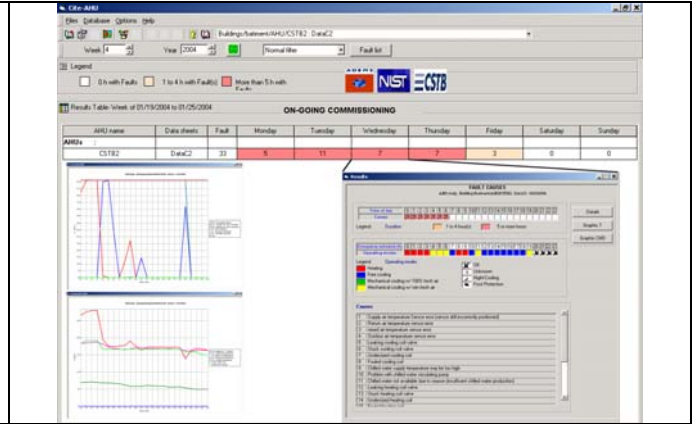

Figure 6: Cite-AHU tools interface

PIA and Operation Diagnostics

Operation Diagnostics uses enhanced visualization techniques to indicate and analyze information that is inherent in data from a control system. Data are collected from the control system and visualized in the form of operational patterns [1]. The operational patterns are generated by PIA, a visualization toolbox developed by Per Isakson, from the Royal Institute of Technology in Stockholm, Sweden [2].

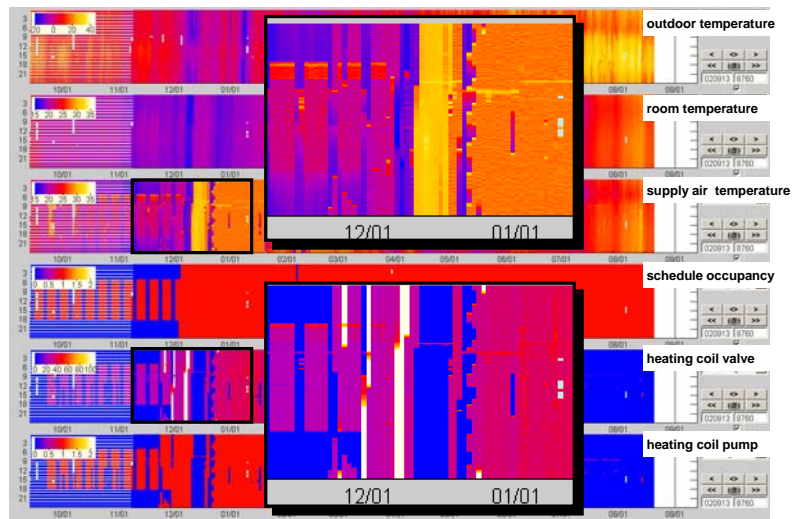

Figure 7: Carpet plot of 6 data points for a time range of 11 months

### TOOLS TESTED DURING THE ANNEX

Prototype software has been developed that enables the automation or semi-automation of functional performance tests. The prototypes are developed sufficiently to enable testing in real commissioning projects in collaboration with the envisioned users of the tools.

Table 3 lists the tools developed and tested during the Annex 40 project.

Table 3: Tools tested during Annex 40

Commissioning Tool	DABO	CLT	Cite-AHU	WebE	Ecole-Cx	Macro Cx	Phil-Tool	OHC-AHU
Country	Canada	Japan	France-USA	Finland	France	Japan	USA	Netherlands
Main End-Users	BOp MC ES	BD BOp BI	BOp MC ES	BOp BOw BS	BOp ES	BOp MC ES	MI CA BOp	MC ES BOp
Type building	Large commercial buildings	Any types	Medium and large commercial buildings	Any types	Medium buildings	Any type	Any types	Large commercial buildings
HVAC system	AHU VAV	Any type	AHU	Any type	Hydronic heating	Any type	AHU	AHU
Type of Cx	On-going Cx	Any type	Re-Cx	On-going Cx	On-going Cx	Re-Cx	-	Re-Cx
Method	Expert system Performance Indice	Emulation	Expert rules	Performance Indice	Expert rules	Performance Indice	Model based	Model based
Communication with BEMS	ODBC & Bacnet driver	XML	OPC	-	Ascii Excel Files	ODBC & Bacnet	-	Data Files

#### Explanations on acronym of the table

**CLT:** Control Logic Tracer

**WebE:** Web-based commissioning

**Ecole-Cx:** Commissioning tool for schools

**OHC-AHU:** Optimal Heating Curve AHU

**BOp:** Building Operator

**ES:** Energy Service Company

**BI:** BEMS Installer

**BOw:** Building Owner

**MI:** Mechanical Installer

**BD:** BEMS Designer

**MC:** Maintenance Company

**BS:** BEMS Supplier

**CA:** Commissioning Agent

**ODBC:** Object Database for Connectivity

**OPC:** Object Linking and Embedding for Process Control

**XML:** eXtensible Markup Language

### CONCLUSIONS

This paper summarizes the different approaches developed during Annex 40 for carrying out commissioning activities using the control system. During our work we have found that control systems in buildings have the potential to greatly improve the commissioning process. In particular, control systems can be used to carry out automated testing on the energy systems in a building in a systematic way. Technologies for carrying out automated commissioning are still in their infancy and very few tools are available for practitioners to use. However, our work has demonstrated that tools can be built using existing infrastructure at relatively low cost. In many cases, tools are software programs that can be implemented on most microprocessor-based platforms.

One obstacle to getting tools deployed on a wide scale is the difficulty in setting up communication with control products from different vendors. However, open protocols such as BACnet and LON are making this easier. Also, there is a cost in identifying the correct sensors and command signals on a control system this cost needs to be balanced against the benefits of the automated methods.

### REFERENCES

- [1] **Baumann, O.** 2003. *Operation Diagnostics – Verification and Optimization of Building and System Operation by Multi-Dimensional Visualization of BEMS Data*, Presented at ICEBO 2003, Berkeley, USA. Ebert-Ingenieur München, Germany.
- [2] **Isakson, P.** 2003. *Data Browser Manual; pmBrush Manual*, Royal Institute of Technology Stockholm, Sweden.
- [3] **Pakanen J., Dexter A. L.**, and al 2001, "Computer-aided Evaluation of HVAC System Performance: the Practical Application of Fault Detection and Diagnosis Techniques in Real Buildings", source book document IEA-ECBCS Annex 34, VTT, Finland, ISBN 951-38-5725-5.
- [4] **Castro, N.S.**, Galler, M. A., Bushby, S. T. "A Test Shell for Developing Automated Commissioning Tools for BACnet Systems" National Conference on Building Commissioning, 2003.