

Performance Testing of Window Installation and Flashing Details.

Theresa A. Weston, Ph.D.

Xuaco Pascual

James Herrin

DuPont Tyvek® Weatherization Systems
Richmond, VA

ABSTRACT

Protection of interface at windows and other penetrations from rainwater intrusion is a primary need of building structures. This is especially true when the building is in a high weather exposure location or in a climate in which the ability for walls to dry may be limited.

Two areas of specific concern are:

- the bottom corners of windows where damage is most commonly seen, and
- the area around curved, arched or round-top windows where it is difficult to install the standard flashing materials.

This paper reviews performance testing of window flashing installation methods commonly used in the trade, as well as improved methods made possible by recent advancements in flashing products.

A series of laboratory tests were designed to determine water resistance, air leakage resistance and durability of several installation methods with different flashing materials. Windows were installed in test wall sections using several methods. The installations were monitored and evaluated for ease of installation and then tested for air leakage and water resistance using ASTM E283 and ASTM E331. The durability of the installations was then evaluated by subjecting the walls to thermal cycling (0 to 160°F) and re-testing for water resistance using ASTM E331. Recommendations for best practice installation based on the testing results and key material selection issues are presented.

INTRODUCTION

Moisture accumulating within building walls and roofs can cause a range of problems ranging from poor insulation performance, to mold growth and further to structural failure of building components. A key component of reducing moisture in building walls is the proper protection of the interface of windows through suitable installation methods and the proper integration of flashing and weather resistive barriers. Leaks at windows have been sited as a

serious issue affecting residential construction. Even a cursory examination of recent trade or technical publications reinforces the need for improved window installation detailing. For example:

- A recent survey of 3,218 homeowner complaints reveals that “window leaks” are one of the top 10 sources of builder callbacks. The primary cause sited for these callbacks, was “omitted or improper flashing details.” [5]
- A field study of building envelope failures in British Columbia surveyed causes of water passage behind sheathing paper and sited 16% occurring at penetrations and an additional 16% occurring at flashings. The conclusion from this study states “The water was found to enter the wall assemblies at interface details; primarily at windows, at the perimeter of decks, balconies and walkways, and at saddle locations. The problems with these details were found to be related to aspects of the design and construction rather than operations or maintenance, or the materials themselves.” [8]
- Investigations in the failures of EIFS-clad buildings the Wilmington, N.C. area show leakage at or around windows was the most frequent source of water penetration. Results of a field study encompassing 2,751 windows, showed that 18% of the windows required sheathing replaced, averaging 16 ft² per window. [3]

Because of the severity of the issues surrounding window installations and leaks a study was initiated to help develop solutions. This study included market research of current builder practice and attitudes, and a review of recommended practices and materials. This review culminated with performance testing of several standard and proposed installation practices incorporating new flashing materials. This paper focuses specifically on the installation practices relating to windows with mounting fins or flanges.

REVIEW OF CURRENT PRACTICES AND ATTITUDES

Interviews with builders from different areas in the United States showed that there is a lot of confusion as to what constitutes flashing, and proper installation. Flashing is uniformly recommended in published guidelines and standards [1, 2, and 7]. Some of the builders interviewed, however, voiced their view that flashing was not necessary and that nailing fins were “self-flashing” in apparent contradiction of accepted guidelines. A survey of 311 builders found that 67% claim to always flash windows. The use of flashing was regional, with the largest fraction of builders (77%) claiming the flash in the Northeast and South Atlantic regions and the least fraction of builders (50%) in the South Central region.

There are currently many different installation and flashing practices used in the field, some of which are recommended in the literature and by trade organizations. [1,4,6,7,9] This study was designed to address the following areas of specific concern:

- the bottom corners of windows where damage is most commonly seen, and
- the area around curved, arched or round-top windows where it is difficult to install the standard flashing materials.

The flashing and installation standards / guidelines can be divided into two categories based on the how the flashing and the rough opening is treated.

- 2-Dimensional Methods: using flashing to extend protection around the perimeter of the window flanges on to the face of the sheathing, and
- 3-Dimensional Methods: using flashing to wrap into the rough opening around the window. Options for 3-dimensional include cut and piecing of flexible flashing materials, “formable” flashing and preformed three-dimensional flashing pieces.

In addition to a variety of installation method recommendations, an informal survey of field installations indicated that builders and installers conduct an extremely wide variety of actual installations. There are regional variations in the construction sequence affecting the integration of flashed windows with the weather resistive barrier. In some areas the weather barrier is applied prior to windows being installed. In other regions the windows are

generally installed prior to the weather barrier installation. In addition several common errors can be found and are listed below.

- Reverse shingling either of flashings with window flanges and/or the weather barrier. This has been noted by several other authors [4, 8].
- Flashing which is cut too short and installed with gaps. Lack of continuous flashing is especially problematic at the heads of curved or round top windows.
- Flashing which is not integrated with a weather resistive barrier.
- Flashing that has been damaged or detached during construction. While damage is most commonly with paper based flashing, detachment has been noted with self-adhesive modified asphalt flashings, especially under cold or wet conditions.

Example errors gathered from the field are shown in figures 1 to 7.

REVIEW OF FLASHING MATERIALS

Flashing materials are divided into three basic categories – rigid, flexible, and self-adhesive flashings. Rigid flashings are traditionally sheet metal which is formed in to head z-flashings or pan flashing for use with non finned windows. Flexible flashings have been traditionally paper-based and used with windows with integral mounting flanges in 2-dimensional flashing methods. More recently self-adhesive flashings have been introduced which are used in place of paper-based flexible flashings. These self-adhesive products made 3-dimensional flashing methods possible because they could be cut and pieced to form “pans” at window sills. Table 1 describes the comments on the performance of common flexible flashing materials from builder/window installer interviews conducted as part of a focus group in 1999. Recently a novel “moldable” self-adhesive flashing has been developed. This flashing combines a composite elasticized top sheet, which has an elastic elongation¹ of 260% with a butyl-based adhesive.

$$^1 \text{ ElasticElongation} = \frac{\text{ExtendedLength}}{\text{OriginalLength}}$$

Figure 1: Reverse shingling at head flange.



Figure 2: Reverse shingling at window head and detached flashing.



Figure 3: Damaged (torn) flashing



Figure 4: Partially detached flashing



Figure 5: Gaps between flashing and weather barrier



Figure 6a and 6b: Gaps in flashing at round-top window head.



Figure 7: Window flange bowed and not sealed



Table 1: Review of Common Flashing Materials based on Builder and Installer Focus Group

	Durability	Barrier	Ease of Use	Comments
Paper	-- curls, tears	-	+ Easily Installed	Associated with leaks
Poly Film/Paper	- tears	+	+ Easily Installed	
Self-Adhesive Modified Asphalt (Bituthmen)	+	+	-- Hot Temperatures - hard to handle materials Cold Temperatures/ Wet Climates - Adhesive doesn't work	Considered best performer of three materials.

PRELIMINARY SYSTEM TESTING

To determine the performance capability and possible “Achilles heels” of common installation methods, wall testing was conducted. These tests also served to define criteria for future wall testing. The four installation methods as described in Table 2 were examined. All walls tested used a flash spun-bonded housewrap as the weather resistive barrier. These walls were subjected to air leakage and simulated wind driven rain testing using standard methods as shown in figure 8. Wall specimens were subjected to testing prior and post installation of siding, and also after thermal cycling. Moisture intrusion during simulated rain tests was evaluated visually and using moisture probes. The position of the moisture probes is shown in figure 9. Upon completion of all scheduled testing, walls were disassembled for additional observations.

These preliminary tests yielded several results and recommendations:

Air Leakage Testing - Siding and caulking effects

Absolute air leakage amounts should not be used to compare the quality of individual installations, as the results were not normalized to isolate the windows from the wall and the installations. The air leakage results, however, were useful to monitor changes in the sealant ability of the caulking of siding and the effect of thermal cycling on caulk seal integrity. The results shown figure 10 show that on all four walls installation and caulking of siding reduced air

leakage through the wall sections. Thermal cycling reduced the effectiveness of the caulk air sealing, increasing the air leakage to that comparable with the unsided wall. The scenario occurred when either acrylic or silicone caulk was used.

Simulated Rain Testing – Siding effects

Results of rain testing before and after siding and after thermal cycling show that results are best when testing is conducted with no siding. The siding when caulked as in this test did not sufficiently challenge the wall with water. Wall to wall variation in siding installation potentially masks differences from the installation methods themselves. Furthermore, the siding tends to obscure some water pathways.

Water Intrusion into Walls

Testing of the unsided walls highlighted several potential water leakage sites. No leakage occurred through the window unit itself. The window was a single fixed pane, and therefore, was expected to be the mostly watertight. When water intruded at the perimeter of the window from any source it collected at the sill and in the framing under the sill. Water leakage around the perimeter of the window occurred in the following areas.

1. Water intrusion at jamb caulk joints
This was noticed on several windows and seemed exacerbated by the installation practice of installing flashing under the jamb flanges instead of on top. In Wall A-2, the caulk was deliberately left off one flange. The resulting difference in framing moisture

is shown in figure 11. If the jamb flashing had been installed over the flange it is expected that the performance of the window would be less dependent on the quality of installation.

2. Framing non-uniformities between the sheathing and framing made it difficult to flash with conventional methods and resulted in “holes” in the flashing, which allowed water to enter behind the flashing and be concentrated behind the flashing. See figure 12.

3. Ease of working with materials impact installation quality. Several passes were required to install some of the flashing materials; especially the self-adhesive flashing that had a very aggressive adhesive.
4. It is difficult to wrap self-adhesive flashing into sill rough openings and maintain a barrier without “holes”. Cut and piece application of self-adhesive flashing requires additional patches to insure barrier quality.

Table 2: Installation Methods used in Preliminary Wall Test

	Flashing Material	Flashing Method			Flashing Sequence	Caulking Procedure
		Sill	Jamb	Head		
Wall A-1	Polymer coated reinforced paper based flashing	2-Dimensional; Shingled under flange and over weather barrier	2-Dimensional; Under flange and weather barrier	2-Dimensional; Over Flange under weather barrier	Weather Barrier after Windows; Weather barrier taped over head and jambs	All four flanges
Wall A-2	Polymer coated reinforced paper based flashing	2-Dimensional; Shingled under flange and over weather barrier	2-Dimensional; Under flange and over weather barrier	2-Dimensional; Over Flange under weather barrier	Weather Barrier before Windows; Weather barrier folded over head flashing	Flanges except for one jamb
Wall A-3	Self-adhesive - Polymer film with modified asphalt adhesive	3-Dimensional; Cut and Pieced to wrap into rough opening; under flange and over weather barrier	3-Dimensional; Cut and Pieced to wrap into rough opening under flange and weather barrier	2-Dimensional; Over Flange under weather barrier	Weather Barrier after Windows; Weather barrier taped over head and jambs	Caulk all four sides from interior
Wall A-4	Self-adhesive - Polymer film with modified asphalt adhesive	3-Dimensional; Cut and Pieced to wrap into rough opening; under flange and over weather barrier	No flashing	2-Dimensional; Over Flange under weather barrier	Weather Barrier before Windows; Weather barrier wrapped into rough opening and over head flashing	Caulk all four sides from interior

Figure 8: Testing Protocol (Wall Test A)

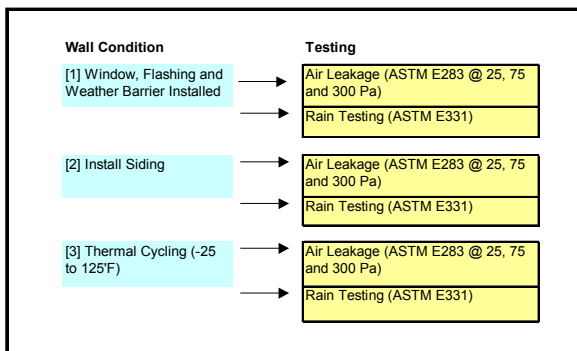

Figure 9: Moisture positions (Preliminary Wall Test)

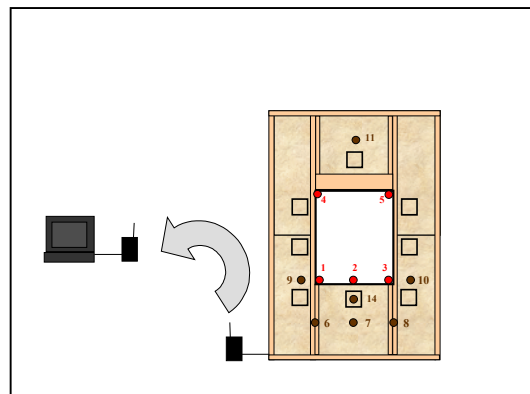

Figure 10: Air Leakage Results

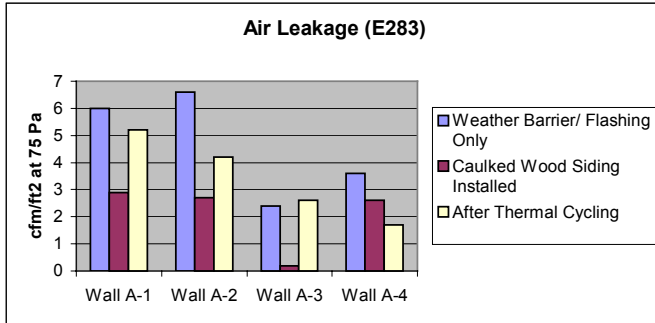

Figure 11: Water intrusion due to lack of caulk joint (Preliminary Wall Test)

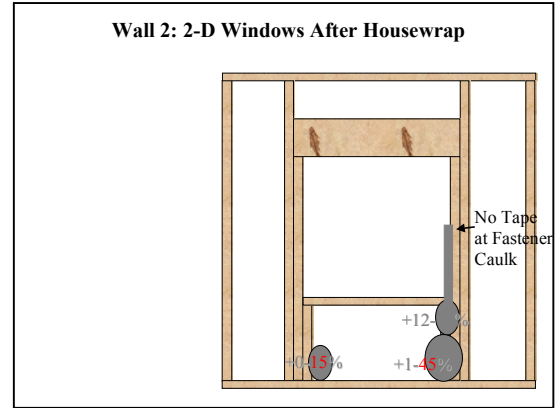
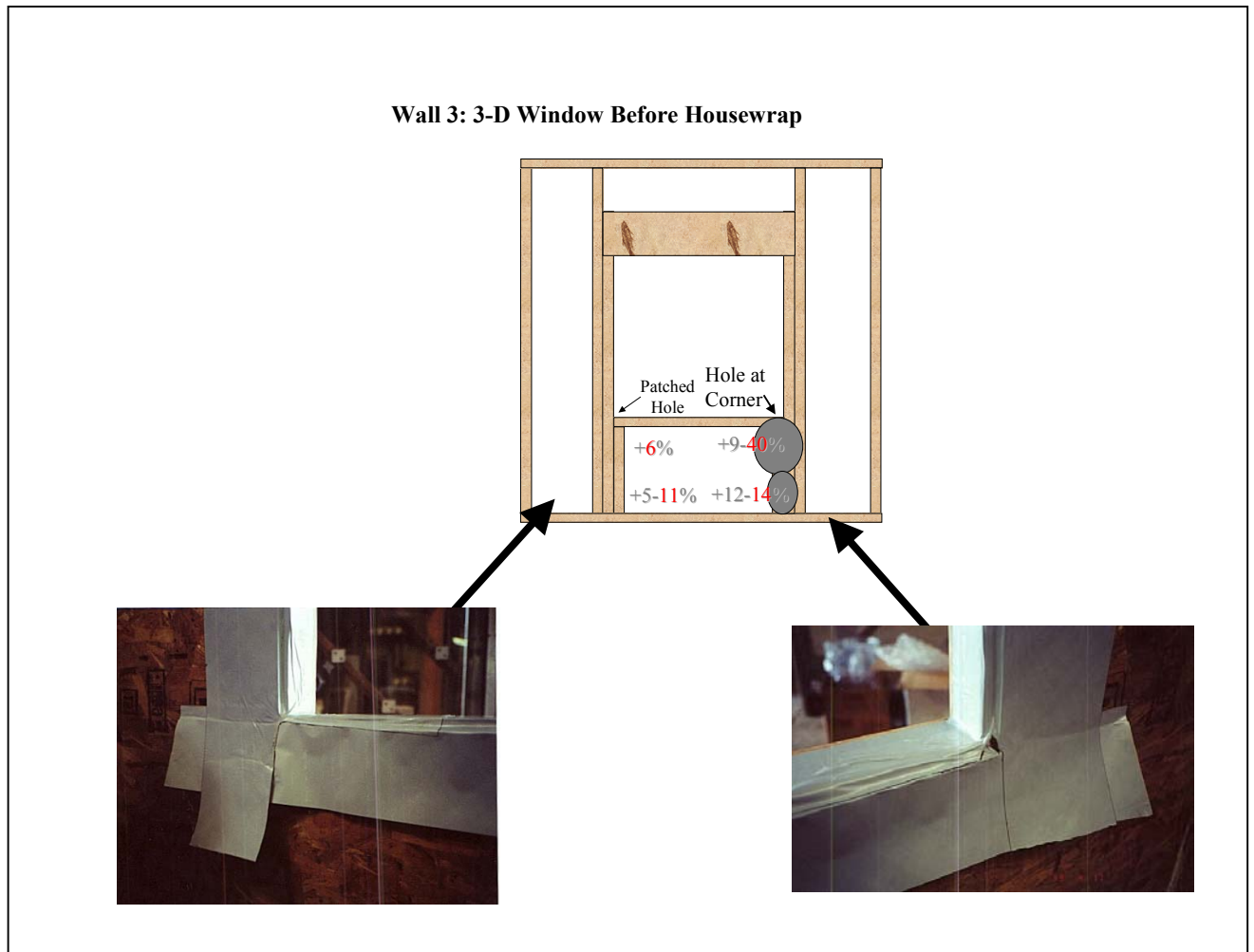

Figure 12: Flashing "Holes" Created by Framing Inconsistencies. (Preliminary Wall Test)



DEVELOPMENT OF IMPROVED INSTALLATION METHODS AND PERFORMANCE TESTING

Based on market research and the initial tests that were conducted, new installation methods, including the new flashing materials required were developed. Figures 13(a) to 14(k) show details of the installation methods. Key aspects of the new installation methods were:

- Creation of a weep system at the bottom flange by not applying caulk on bottom flange (trapped moisture was observed in preliminary testing and also noted in literature)
- Seamless 3-dimensional flashing on sill and 6" up either side rough opening -- made possible by the elasticized self-adhesive flashing described earlier.
- Self-adhesive flashing applied over jamb and head flanges.
- Air seal by interior caulk joint
- Elasticized self-adhesive flashing allowed single piece continuous head flashing for round-top window applications.

The proposed installation methods were tested for efficacy and durability using the protocol outlined in figure 15. Windows were installed in 8' x 8' walls. All window units consisted of a fixed pane half round window mullied to a fixed pane rectangular window. See figure 16. A description of the walls tested, including comparison and variant walls is shown in Table 3. Air infiltration and exfiltration was tested using the standard ASTM E283 procedure with pressure differences of 25, 50, and 300 Pa. Air leakage measurements are not applicable for comparing installations, as leakage through windows was not isolated from the wall or perimeter leakage. In addition, caulk air sealant joints were partially omitted on some walls to facilitate the observation of water intrusion during simulated rain testing. Air leakage measurements were used primarily to monitor sealant durability through thermal cycling. Water infiltration was tested using the standard ASTM E331 method. Infiltration pressures were set at 25, and 75 Pa for 15 minutes periods at each pressure level. Water infiltration was monitored visually and with moisture sensors. Figure 17 shows the positions of the moisture probes in the wall specimens.

INSTALLATION PERFORMANCE TESTING RESULTS

The testing confirmed that the proposed installation techniques performed well both by providing an excellent barrier to water entry and by being forgiving of incidental water intrusion at the window. Specific results and conclusions follow.

Water intrusion points

The primary rain entry point was the horizontal window mullion. Water entered at virtually all the windows tested. Thermal cycling exacerbated this water entry. Figure 18 shows a typical leak at the window mullion. The majority of water appeared to enter through the joint itself. Additionally, this flange at these joints has an irregular shape and is more difficult to seal with flashing. To seal this area, flashing needed to have enough flexibility to mold to the jamb profile. Stretching of the elasticized flashing reduced its flexibility and is not recommended.

Water management

The seamless 3-dimensional flashing combined with not applying caulk to the bottom flange of the window allowed for any water entry to drain to exterior. Water that entered the comparison wall, in which the bottom flange was caulked, was trapped and collected at the bottom of the window rough opening (see figure 19).

Round top window head flashing installation

All of the flashing techniques used were successful in stopping water intrusion at the window head. The elasticized self-adhesive laminate was significantly faster and easier to install and required less material than shingling methods. Figures 20a, b, and c show the head flashing details prior to covering with the weather barrier. The installation variation of applying the self-adhering head flashing over the weather barrier was also tested (figure 21). Although no water intrusion was observed, this is a reverse shingling situation and water entry would be dependent on the quality of the seal of the flashing to the weather barrier and in general is not recommended as such an installation could potentially divert water into a wall system.

Flashing width

Self-adhesive flashing with widths from 5" to 10" was tested on the jambs of the windows with weather barrier installed prior to window

installation. All wall specimens performed in stopping water intrusion.

Thermal aging

Several of the wall specimens were tested after thermal cycling versus as installed to help understand the long-term performance of the walls. Wall specimens were subjected to seven days of a repeated 6-hour temperature cycle. Initially the cycle was chosen to range from 0°F to 180°F based on the AAMA default recommendations. After observing severe damage to the vinyl windows due to the 180°F temperature, the cycle range was changed to 0°F to 160°F. The elasticized self-adhesive flashing and the poly-coated paper flashing showed no deterioration after thermal cycling. Moderate buckling and wrinkling of the self-adhesive modified asphalt flashing was observed (figure 22). Water intrusion increased after thermal cycling. The horizontal mullions continued to be the primary point of leakage, but leakage occurred sooner and at lower pressures during the test.

Construction sequencing

The proposed installation methods for the weather barrier being installed before window and for the weather barrier being installed after the window both performed well. When the window is installed prior to the weather barrier, the performance of the combined WRB and window flashing system is somewhat dependent on the tape seal around the window. If this seal is breached water can enter the wall between the weather barrier and the flashing. Figure 23 shows water that has entered the wall between the jamb flashing and the weather barrier and then traversed laterally inward across the nine-inch wide flashing.

Installation temperature

The majority of the installations were conducted at room temperature, and then tested 24 hours after installation. To simulate a wider range of field installations, some installations were performed in a thermal chamber. In these cases the materials and wall sections were placed in the thermal chamber prior to installation and pre-conditioned to the installation temperature. The installation temperatures and 24-hour temperature profiles following installation were determined based on WYEC weather data files. The temperature profiles used are listed in table 4. This testing identified the removal of release paper and potential pre-stretching of the elasticized flashing as a potential hot temperature installation issue. Cold temperature installation issues that were identified were reduced adhesion and flexibility of the flashing material. Both the hot and cold temperature installed walls performed well in the air and water intrusion testing.

CONCLUSIONS AND RECOMMENDATIONS

The results of this study support the following window installation and flashing practices.

- 3-dimensional sill flashing should be seamless to fully protect the rough opening.
- A weep system to provide a potential escape path for water should be created at the bottom of the window by eliminating caulk at the bottom flange.

This study was limited in scope and additional research should be conducted to examine at a wider range of installation conditions and window types.

Figure 13: Installation when weather barrier is installed before the window.

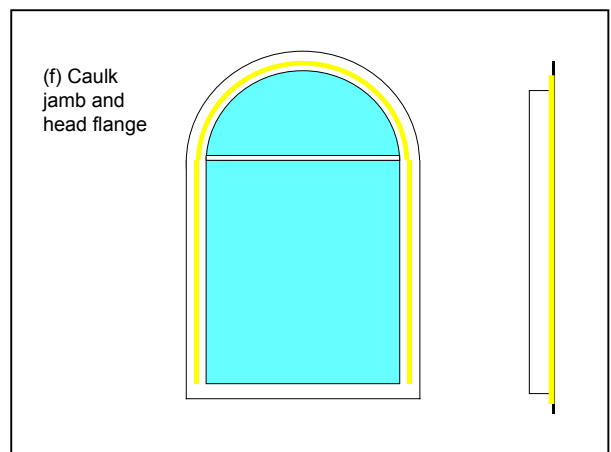
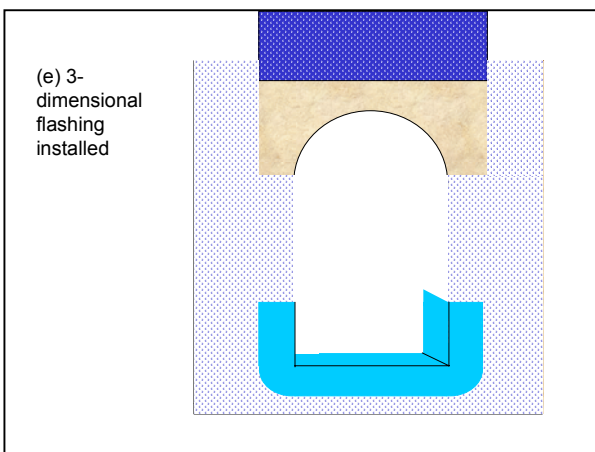
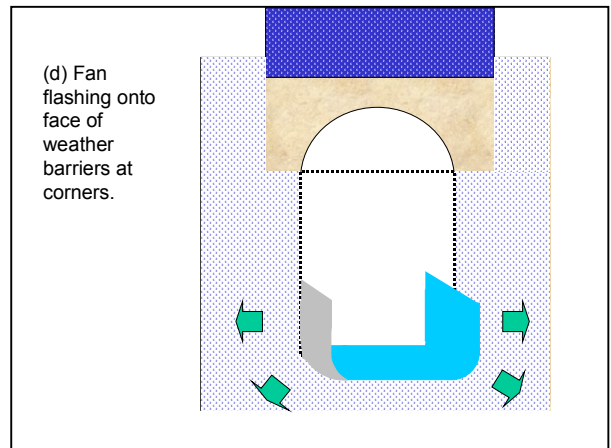
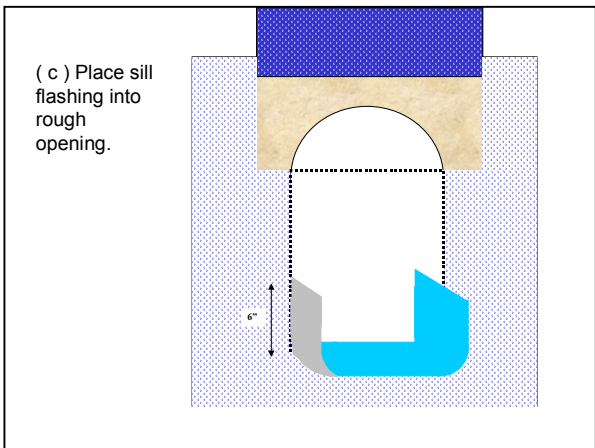
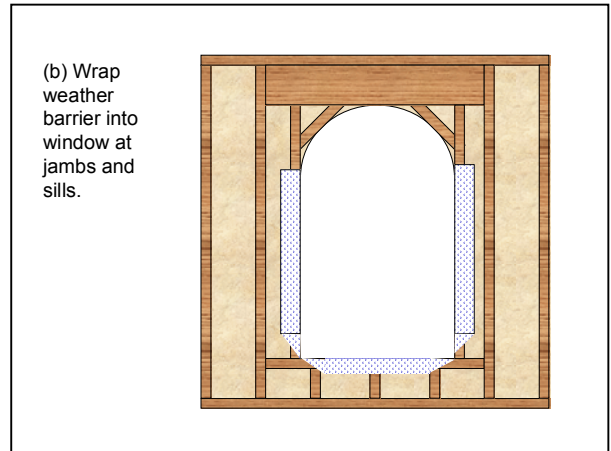
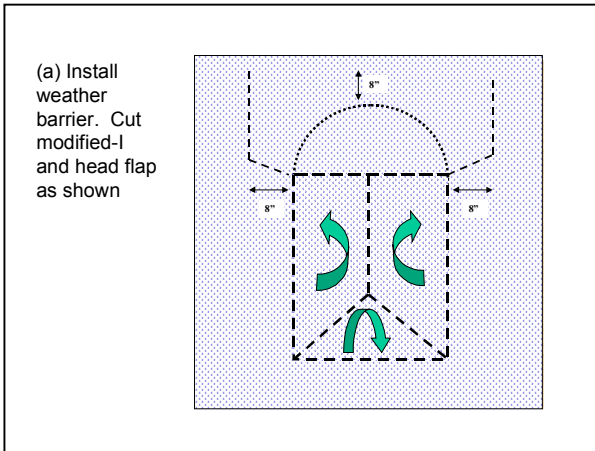

Figure 13: Installation when weather barrier is installed before the window. (cont.)

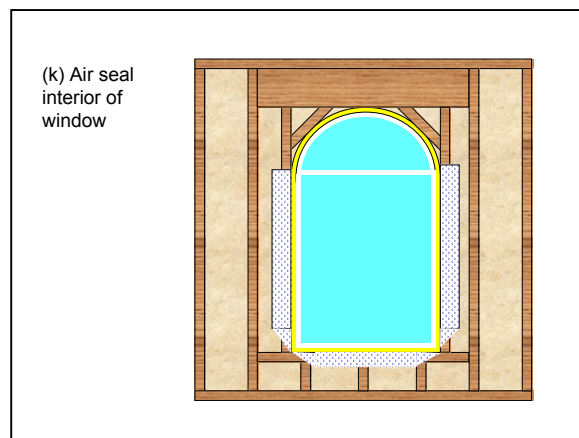
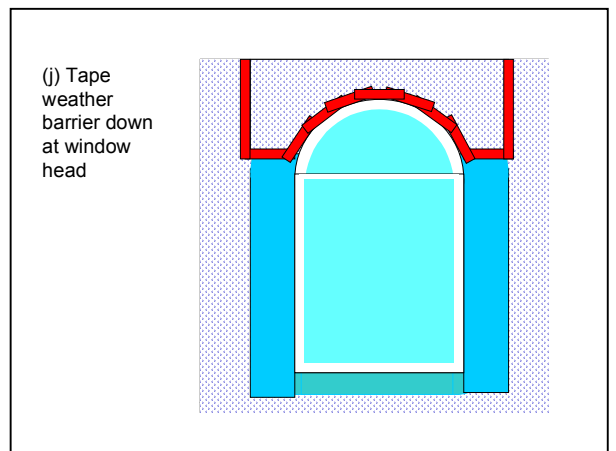
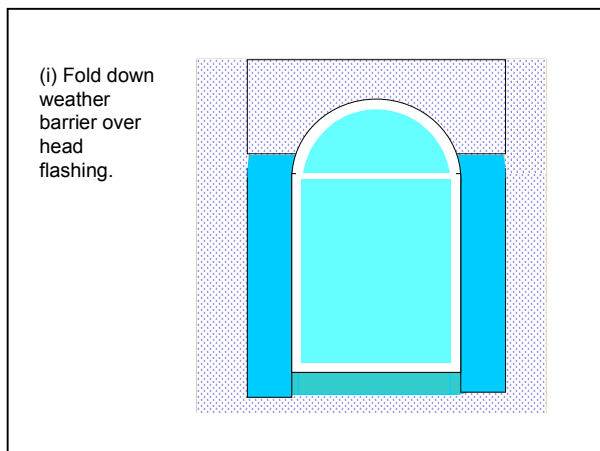
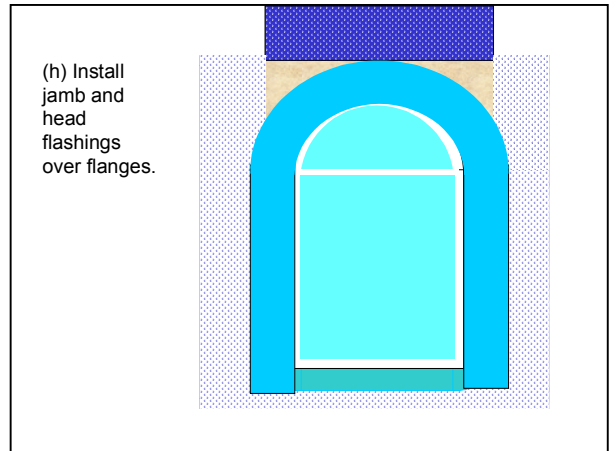
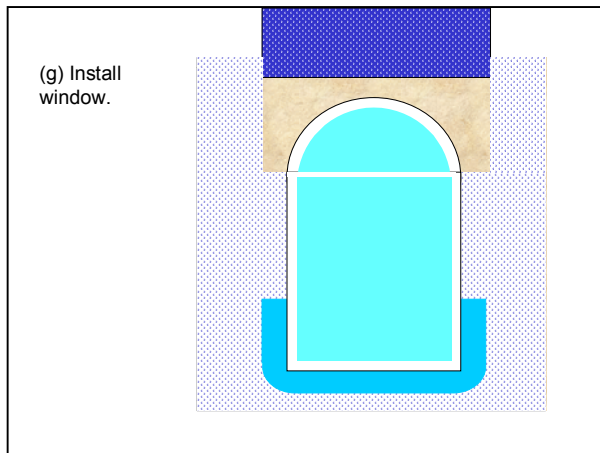

Figure 14: Installation when weather barrier is installed after the window.

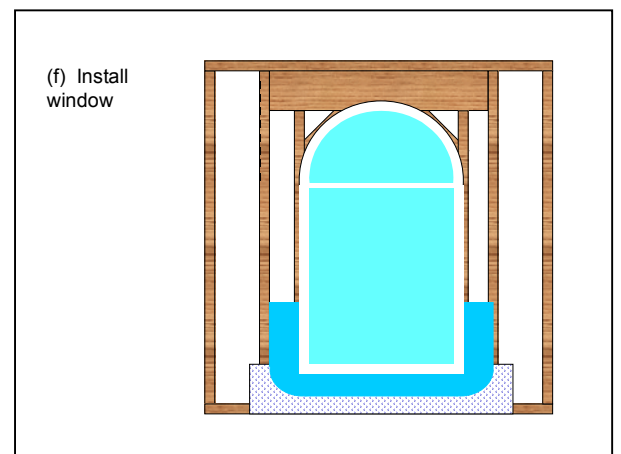
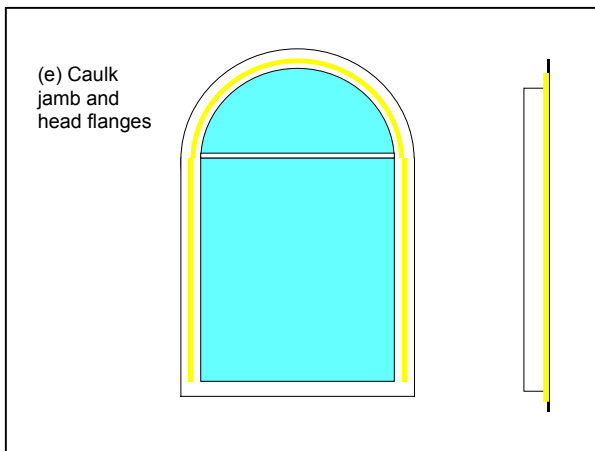
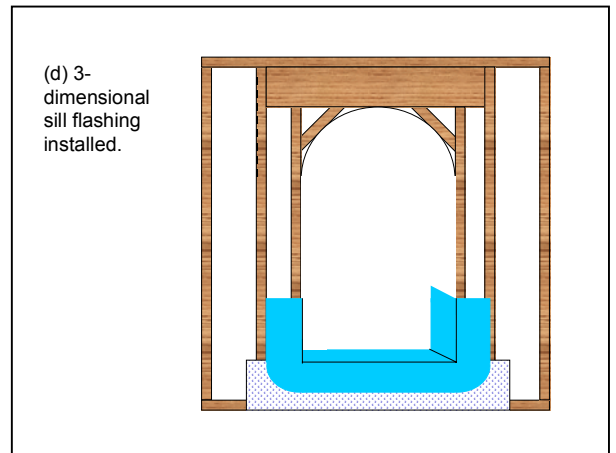
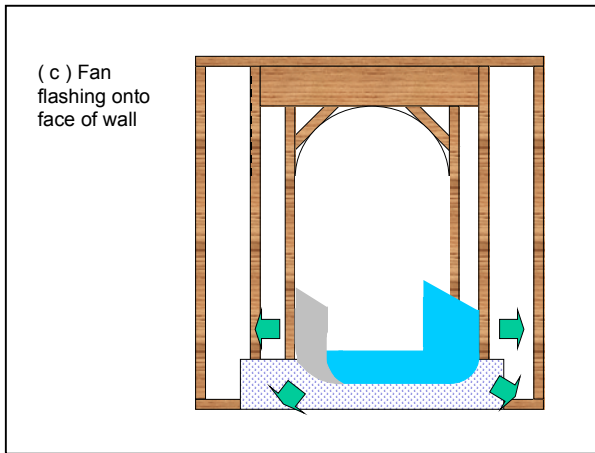
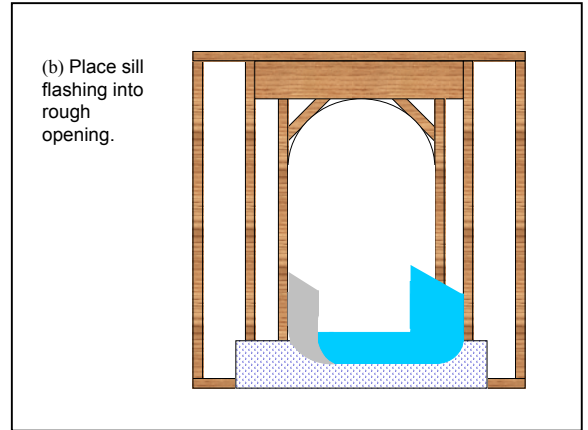
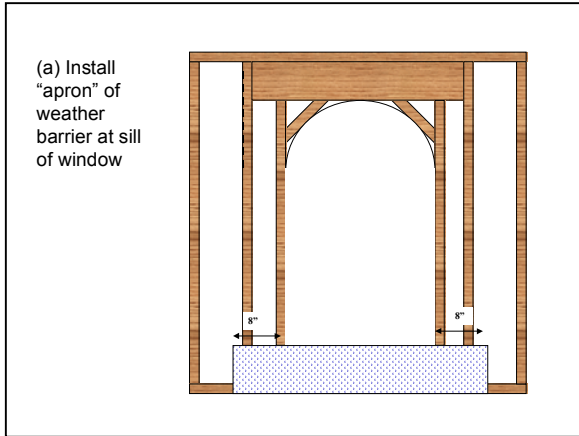

Figure 14: Installation when weather barrier is installed after the window. (cont.)

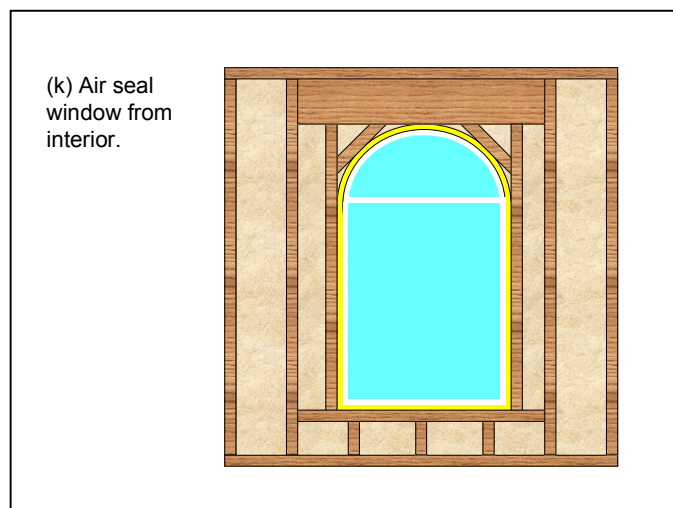
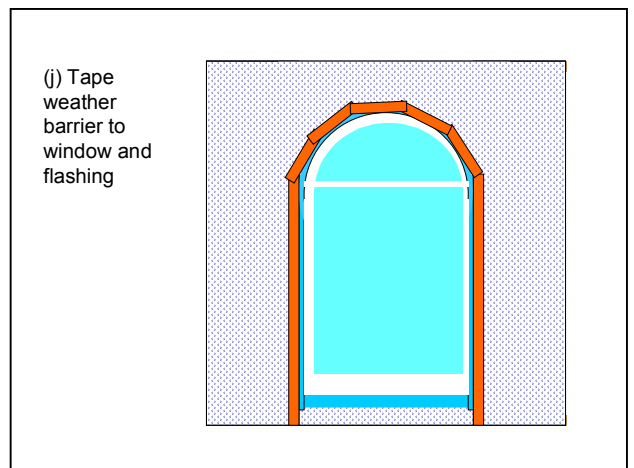
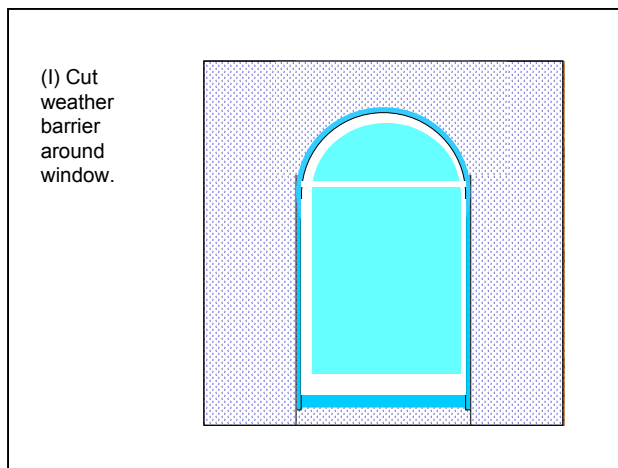
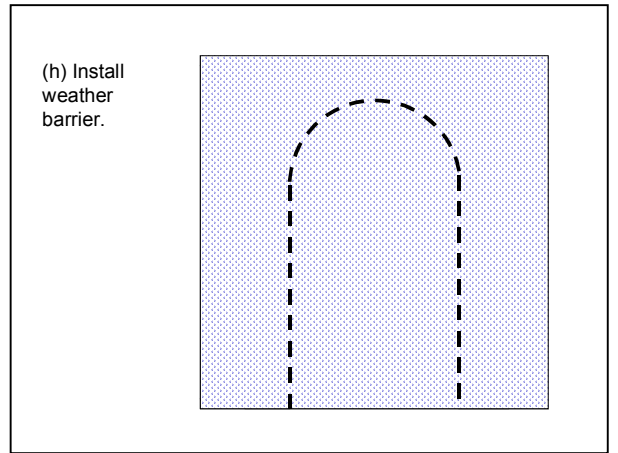
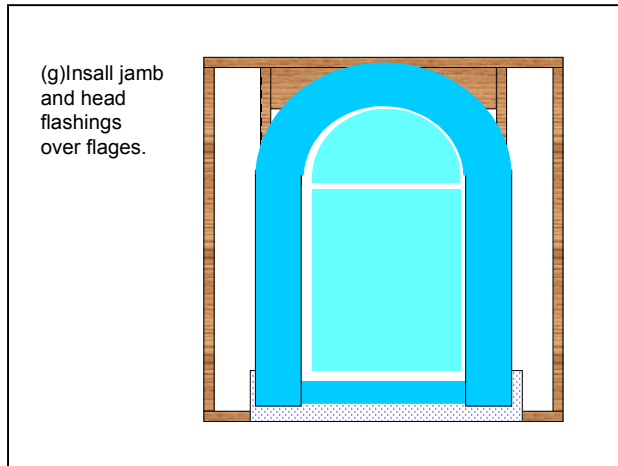

Figure 15: Test Protocol

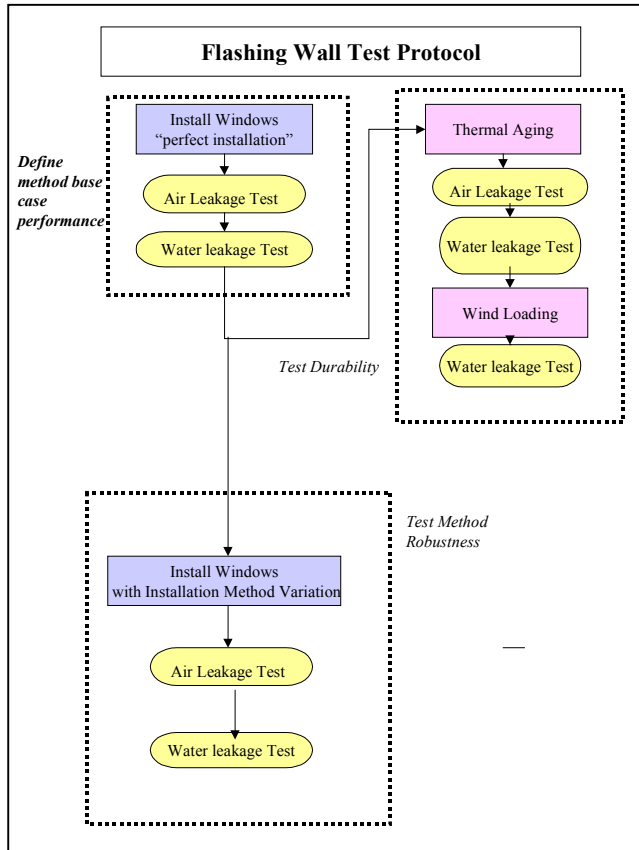

Figure 17: Moisture sensor position

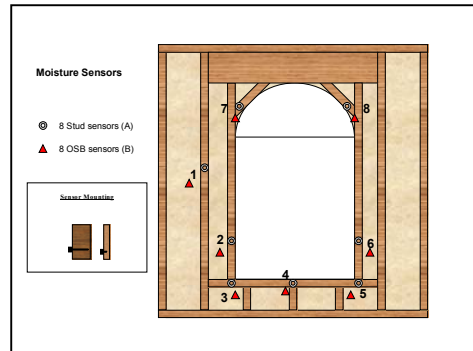

Figure 18: Water intrusion at window horizontal mullion

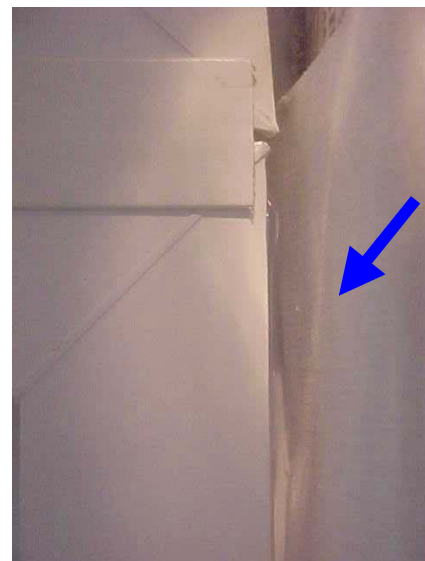

Figure 16. Test Wall configuration

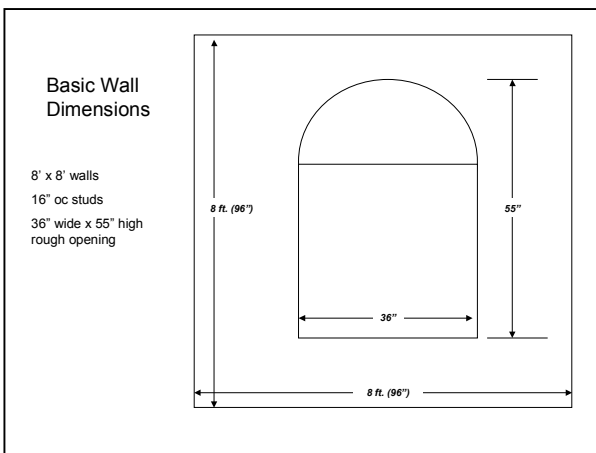

Figure 19: Water trapped by caulked sill flange collects at the bottom of window -- Wall C2.



Table 3: Installation Development Performance Testing – Wall Test Specimens

	WALL ID	FLASHING TYPE	WEATHER RESISTIVE BARRIER	INSTALLATION METHOD	VARIATION(S)
Comparison Walls	C1	9" Poly/Paper	60 min Grade D Building Paper	open stud / windows before building paper / 2D / Caulk entire flange	
	C2	Self-adhesive modified asphalt	Spun Bonded Polyolefin Houswrap	OSB / windows after weather barrier / 2D / Caulk entire flange	
Proposed Installation Method	L1-8-A	Elasticized Self-adhesive (8" wide)-Surface laminate #1	Spun Bonded Polyolefin Houswrap	OSB / windows after weather barrier / 8" sill	
	L1-10-A	Elasticized Self-adhesive (10" wide)-Surface laminate #1	Spun Bonded Polyolefin Houswrap	OSB / windows after weather barrier/ 10" sill	
	L1-8-D	Elasticized Self-adhesive (8" wide)-Surface laminate #1	Spun Bonded Polyolefin Houswrap	Open stud / windows before weather barrier / 8" sill	
	L2-8-A	Elasticized Self-adhesive (8" wide)-Surface laminate #2	Spun Bonded Polyolefin Houswrap	OSB / windows after weather barrier / 8" sill	
	L3-5-A	Elasticized Self-adhesive (5" wide)-Surface laminate #3	Spun Bonded Polyolefin Houswrap	OSB / windows after weather barrier / 8" sill	
Installation Variants	V1	Elasticized Self-adhesive (8" wide)-Surface laminate #1	Spun Bonded Polyolefin Houswrap	OSB / windows after weather barrier / 8" sill	No perimeter sealing (caulk)
	V2	Elasticized Self-adhesive (8" wide)-Surface laminate #1	Spun Bonded Polyolefin Houswrap	OSB / windows after weather barrier / 8" sill	Head and Jamb flashing installed in three pieces
					>one side overlap joint
	V3	Elasticized Self-adhesive (8" wide)-Surface laminate #1	Spun Bonded Polyolefin Houswrap	OSB / windows after weather barrier / 8" sill	Secondary fasteners through flashing
					>wrinkles/bubbles in corner
V4	Elasticized Self-adhesive (8" wide)-Surface laminate #1	Spun Bonded Polyolefin Houswrap	OSB / windows after weather barrier / 8" sill	>overstretched on jamb	
				Head flashing reversed shingled on Tyvek (no overlapping flap)	
V5	Elasticized Self-adhesive (8" wide)-Surface laminate #1	Spun Bonded Polyolefin Houswrap	Open stud / windows before weather barrier / 8" sill	No Tape	

Figure 20: Round-top head flashing details. (a) Elasticized self-adhesive flashing (Wall L1-8-A), (b) Poly/paper flashing and caulk (Wall C1), (c) Self-adhesive modified asphalt flashing (Wall C2).

(a)



(b)



(c)



Figure 21: Round-top head flashing with reverse shingling (Wall V4)



Figure 22: Self-adhesive modified asphalt flashing after thermal cycling (Wall C2)



Figure 23: Water entering between the weather barrier and the jamb flashing.



Table 4: Extreme temperature installation conditions

TEMPERATURE PROFILE				
Installation Conditions	Installation Temperature	"Night-time" Temperature	Daytime Temperature	Weather Data Basis
Hot Climate	100 F	75 F	110 F	Phoenix, AZ - June, July, August
Cold Climate	30 F	0 F	50 F	November - Bismark ND, Caribou ME, Minneapolis MN, Edmonton Alberta

REFERENCES

1. ASTM, Standard Practice for Installation of Exterior Windows, Doors and Skylights (E2112-2001).
2. Bateman, Robert, Nail-on Windows: Installation and Flashing Procedures for Windows & Sliding Glass Doors, 1995, 1st Edition; DTA, Inc. Mill Valley, CA 94941
3. Best, Al et. al., Water Intrusion and Remediation for Wood Frame Homes with Exterior Insulation and Finish Systems (EIFS), The EIFS Review Committee, January, 1999.
4. Fisette, Paul, Details That Keep Walls Watertight, Building Materials and Wood Technology Web-site, University of Massachusetts at Amhearst, 1997.
5. Home Buyers Warranty Corporation, Top 10 Callback Items and How You Can Avoid Them, 2000.
6. Larson, James, "How to Avoid Common Flashing Errors", Fine Homebuilding, April-May 1998.
7. Lstiburek, Joseph, Builders Guide, Energy Efficient Building Association, 1997.
8. Morrison Hershfield Limited, Survey of Building Envelope Failures on the Coastal Climate of British Columbia, prepared for CMHC, November 22, 1996.
9. Webber, Ron, "Stucco Flashing Details", Journal of Light Construction, October 1998.

LIST OF TABLES

- Table 1: Review of Common Flashing Materials based on Builder and Installer Focus Group
 Table 2: Installation Methods used in Preliminary Wall Test
 Table 3: Installation Development Performance Testing – Wall Test Specimens
 Table 4: Extreme temperature installation conditions

LIST OF FIGURES

- Figure 1: Reverse shingling at head flange.
 Figure 2: Reverse shingling at window head and detached flashing.
 Figure 3: Damaged (torn) Flashing
 Figure 4: Partially detached flashing
 Figure 5: Gaps between flashing and weather barrier
 Figure 6a and 6b: Gaps in flashing at round-top window head.
 Figure 7: Window flange bowed and not sealed.

Figure 8: Testing Protocol (Preliminary Wall Test)

Figure 9: Moisture positions (Preliminary Wall Test)

Figure 10: Air Leakage Results (Preliminary Wall Test)

Figure 11: Water intrusion due to lack of caulk joint (Preliminary Wall Test, Wall A-2)

Figure 12: Flashing "Holes" Created by Framing Inconsistencies. (Preliminary Wall Test, Wall A-3)

Figure 13: Installation when weather barrier is installed before the window.

Figure 14: Installation when weather barrier is installed after the window.

Figure 15: Test Protocol: Installation development and performance testing.

Figure 16. Test Wall configuration

Figure 17: Moisture sensor position

Figure 18: Water intrusion at window horizontal mullion.

Figure 19: Water trapped by caulked sill flange collects at the bottom of window (Wall C2).

Figure 20: Round-top head flashing details. (a) Elasticized self-adhesive flashing (Wall L1-8-A), (b) Poly/paper flashing and caulk (Wall C1), (c) Self-adhesive modified asphalt flashing (Wall C2).

Figure 21: Round-top head flashing with reverse shingling (Wall V1)

Figure 22: Self-adhesive modified asphalt flashing after thermal cycling (Wall C2)

Figure 23: Water entering between the weather barrier and the jamb flas

**Homes produced with airtight duct systems
(around 15% savings in Htg and Cooling Energy)**

Palm Harbor Homes	22,000
Southern Energy Homes	8,000
Cavalier Homes	1,000
	===
Subtotal	31,000

Technical measures incorporated in BAIHP homes include some or many of the following features - better insulated envelopes (including Structural Insulated Panels and Insulated Concrete Forms), unvented attics, "cool" roofs, advanced air distribution systems, interior duct systems, fan integrated positive pressure dehumidified air ventilation in hot humid climates, quiet exhaust fan ventilation in cool climates, solar water heaters, heat pump water heaters, high efficiency right sized heating/cooling equipment, and gas fired combo space/water heating systems.

**HOMES BY THE FLORIDA HOME ENERGY
AND RESOURCES ORGANIZATION
(FL.H.E.R.O.)**

Over 400 single and multifamily homes have been constructed in the Gainesville, FL area with technical assistance from FL H.E.R.O. These homes were constructed by over a dozen different builders. In this paper data from 310 of these homes is presented. These homes have featured better envelopes and windows, interior and/or duct systems with adequate returns, fan integrated positive pressure dehumidified air ventilation, high efficiency right sized heating/cooling equipment, and gas fired combo space/water heating systems. The innovative outside air (OA) system is described below.

The OA duct is located in the back porch (Figure 1) or in the soffit (Figure 2). The OA is filtered through a 12"x12" filter (which is readily available) located in a grill (Figure 3) which is attached to the OA duct box. The flex OA duct size varies depending on the system size - 4" for up to 2.5 tons, 5" for 3 to 4 ton and 6" for a 5 ton system. The OA duct terminates in the return air plenum after a manually adjustable butterfly damper (Figure 4).



Figure 1 OA Intake Duct in Back Porch



Figure 2 OA Intake Duct in Soffit



Figure 3 Filter Backed Grill Covering the OA Intake

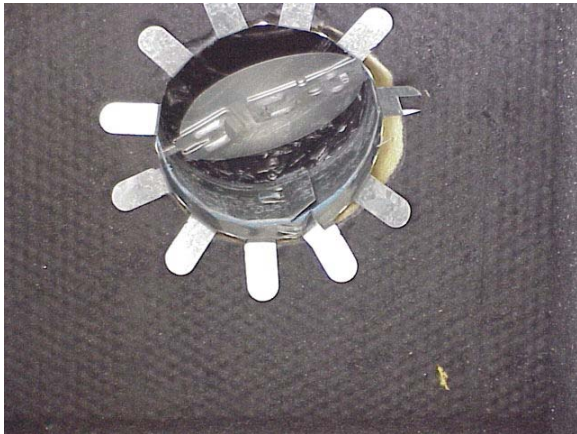

Figure 4 Butterfly Damper for OA control

The damper can be set during commissioning and closed by the homeowner in case the OA quality is poor (e.g. forest fire). This system introduces filtered and conditioned ventilation air only when the cooling or heating system is operational. The ventilation air also positively pressurizes the house. Data on the amount of ventilation air or positive pressurization is not available from a large sample of homes. A few measurements indicate that about 25 to 45 cfm of ventilation air is provided which pressurizes the house in the range of +0.2 to +0.4 pascals.

Measured Home Energy Ratings (HERS) and airtightness on these FL. H.E.R.O. homes is presented next in figures 5 through 8. Data is presented for both single family detached (SF) and multifamily homes (MF). See Table 2 below.

Table 2. Summary statistics on FL.H.E.R.O. Homes
n = sample size

	SF	MF
Median cond area	1,909	970
% constructed with 2x4 frame or frame and block	94%	100%
Avg. Conditioned Area, ft ²	1,993 (n=164)	1,184 (n=146)
Avg. HERS score	87.0 (n=164)	88.0 (n=146)
Avg. ACH50	4.5 (n=164)	5.2 (n=146)
Avg. Qtot (CFM25 as %of floor area)	6.9% (n=25)	5.0% (n=72)
Avg. Qout (CFM25 as %of floor area)	3.0% (n=15)	1.4% (n=4)

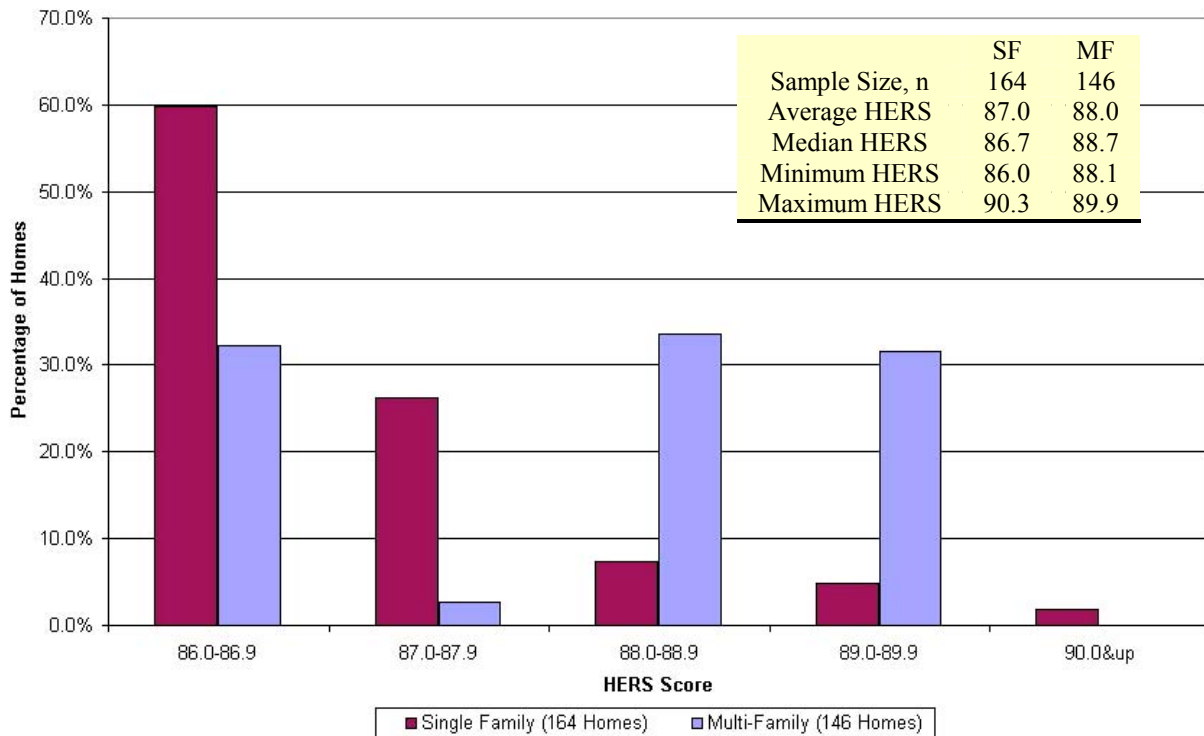

Figure 5 HERS Scores for FL H.E.R.O. Homes

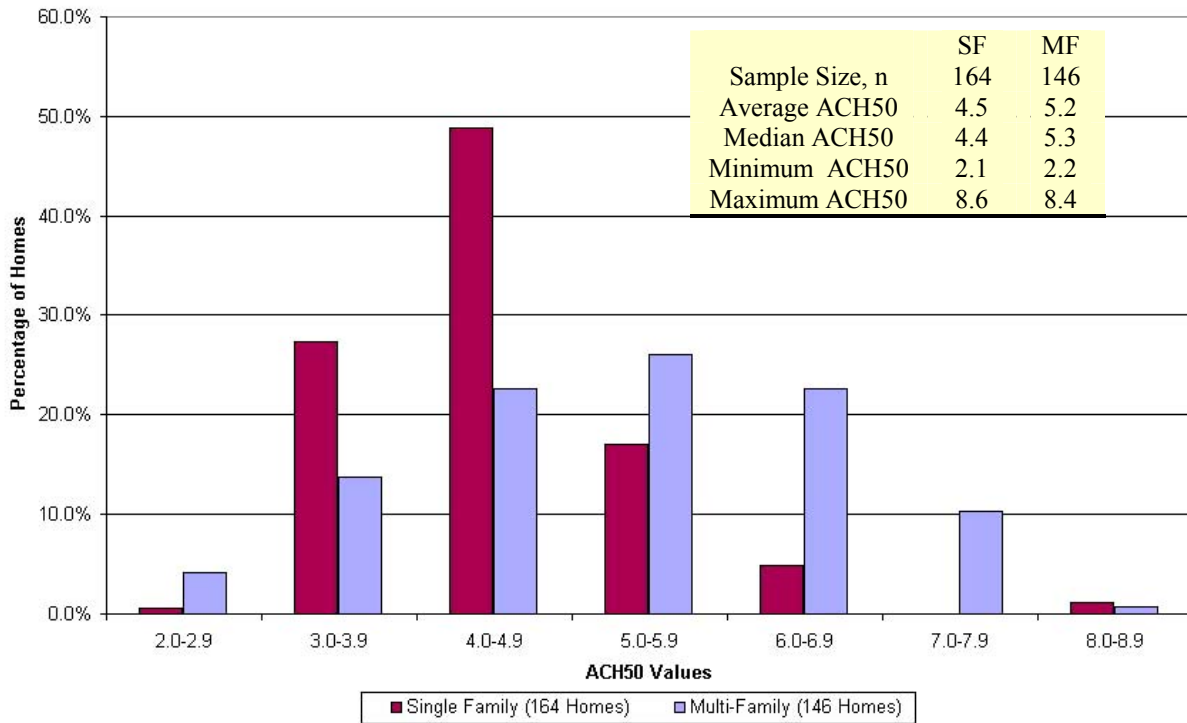

Figure 6 ACH50 Values for FL H.E.R.O. Homes

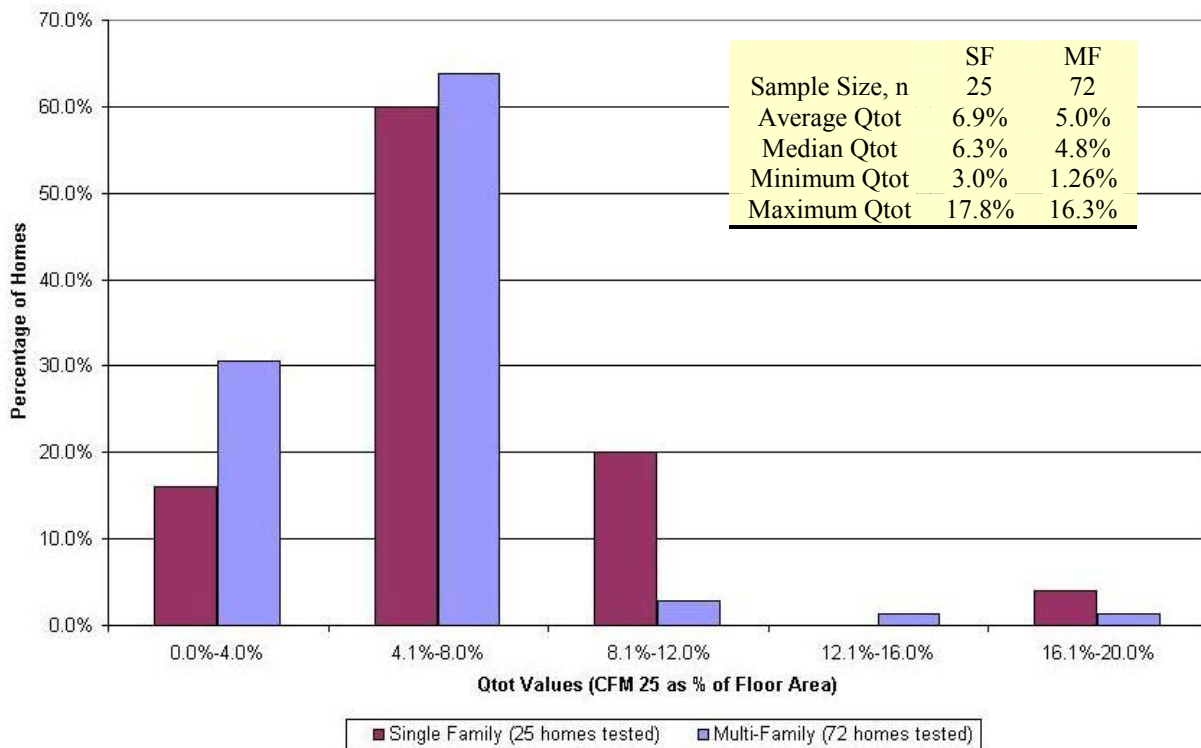

Figure 7 Qtot Values for FL H.E.R.O. Homes

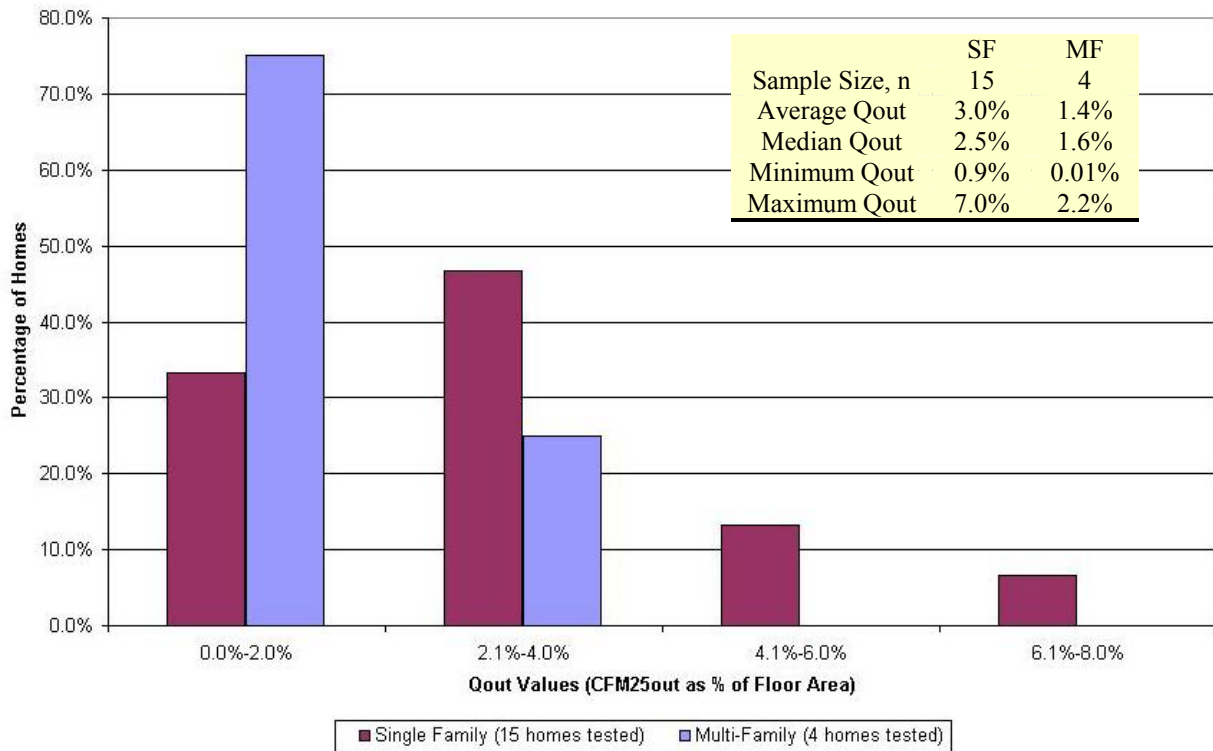

Figure 8 Qout Values for FL H.E.R.O. Homes

Data is available for other typical non BAIHP, new Florida homes (FPL, 1995 and Cummings et al, 2001). The FPL study had a sample size of over 300 single family homes and the median Qout was 7.5%, three times that of the FL H.E.R.O. homes. In the Cummings study of 11 homes the measured average values were: ACH50= 5.7, Qtot=9.4% and Qout=4.7%. Although the sample sizes are small the FL H.E.R.O. homes appear to have significantly more airtight duct systems than typical homes.

The remainder of the paper presents status of other tasks of the BAIHP project.

OTHER BAIHP TASKS

Moisture Problems in HUD code homes

The BAIHP team expends considerable effort working to solve moisture problems in existing manufactured homes in the hot, humid Southeast.

Some manufactured homes in Florida and the Gulfcoast have experienced soft walls, buckled floors, mold, water in light fixtures and related problems. According to the Manufactured Housing Research Alliance (MHRA), who we collaborate with, moisture problems are the highest priority

research project for the industry.

The BAIHP team has conducted diagnostic tests (blower door, duct blaster, pressure mapping, moisture meter readings) on about 40 such problem homes from five manufacturers in the past two years and shared the results with MHRA. These homes were newly built (generally less than 3 years old) and in some cases just a few months old when the problems appeared. The most frequent causes were:

- Leaky supply ducts and/or inadequate return air pathways resulting in long term negative pressures.
- Inadequate moisture removal from oversized a/c systems and/or clogged condensate drain, and/or continuous running of the air handler fan.
- Presence of vinyl covered wallboard or flooring on which moist air condenses creating mold, buckling, soft walls etc.
- Low cooling thermostat set point (68-75F), below the ambient dew point.
- Tears in the belly board and/or poor site drainage and/or poor crawlspace ventilation creating high rates of moisture diffusion to the floor.

Note that these homes typically experience very high

cooling bills as the homeowners try to compensate for the moisture problems by lowering the thermostat setpoints. These findings have been reported in a peer reviewed paper presented at the ASHRAE IAQ 2001. conference (Moyer et al)

The Good News:

As a result of our recommendations and hands-on training, BAIHP partner Palm Harbor Homes (PHH) has transformed duct design and construction practices in all of its 15 factories nationwide producing about 11,000 homes/yr. All Palm Harbor Home duct systems are now constructed with mastic to nearly eliminate air leakage and produced with return air pathways for a total cost of <\$10/home!! The PHH factory in AL which had a high number of homes with moisture problems has not had a single problem home the past year!

Field Monitoring

Several houses and portable classrooms are being monitored and the data displayed on the web. (Visit <http://www.infomonitors.com/>). Of special interest is the side-by-side monitoring of two manufactured homes on the campus of the North Carolina A & T U. where the advanced home is saving about 70% in heating energy and nearly 40% in cooling energy, proving that the Building America goal can be met in manufactured housing. Other monitored sites include the Washington State U. Energy House in Olympia, WA; the Hoak residence in Orlando, FL; two portable classrooms in Marysville, WA; a classroom each in Boise, ID and Portland, OR. See other papers being presented at this symposium for details on two recently completed projects giving results from duct repairs in manufactured homes (Withers et al) and side by side monitoring of insulated concrete form and base case homes (Chasar et al).

“Cool” Roofs and Unvented Attics

Seven side-by-side Habitat homes in Ft. Myers, FL. were tested under unoccupied conditions to examine the effects of alternative roofing strategies. After normalizing the data to account for occupancy and minor differences in thermostat set points and equipment efficiencies, the sealed attic saved 9% and the white roofs saved about 20% cooling energy compared to the base case house with a dark shingle roof for the summer season in South Florida. Visit <http://www.fsec.ucf.edu/%7Ebdac/pubs/coolroof/exum.htm> for more information.

Habitat for Humanity

Habitat for Humanity affiliates work in the local community to raise capital and recruit volunteers.

The volunteers build affordable housing for and with buyers who can't qualify for conventional loans but do meet certain income guidelines. For some affiliates, reducing utility costs has become part of the affordability definition.

To help affiliates make decisions about what will be cost effective for their climate, BAIHP researchers have developed examples of Energy Star homes for more than a dozen different locations. These are available on the web at http://www.fsec.ucf.edu/bldg/baihp/casestud/hfh_estar/index.htm. The characteristics of the homes were developed in conjunction with Habitat for Humanity International (HFHI), as well as Executive Directors and Construction Managers from many affiliates. Work is continuing with HFHI to respond to affiliates requesting a home energy rating through an Energy and Environmental Practices Survey. 36 affiliates have been contacted and home energy ratings are being arranged using combinations of local raters, Building America staff, and HFHI staff.

HFHI has posted the examples of Energy Star Habitat homes on the internal web site PartnerNet which is available to affiliates nationwide.

“Green” Housing

A point based standard for constructing green homes in Florida has been developed and may be viewed at <http://www.floridagreenbuildings.org/>. The first community of 270 homes incorporating these principles is now under construction in Gainesville, FL. The first home constructed and certified according to these standards has won an NAHB energy award.

BAIHP researchers are participating as building science - sustainable products advisor to the HUD Hope VI project in Miami, redeveloping an inner city area with over 500 units of new affordable and energy efficient housing.

Healthy Housing

BAIHP researchers are participating in the development of national technical and program standards for healthy housing being developed by the American Lung Association.

A 50-year-old house in Orlando is being remodeled to include energy efficient and healthy features as a demonstration project.

EnergyGauge USA®

This FSEC developed software uses the hourly DOE 2.1E engine with FSEC enhancements and a user-friendly front end to accurately calculate home

energy ratings and energy performance. This software is now available. Please visit <http://energygauge.com/> for more information.

Industrial Engineering Applications

The UCF Industrial Engineering (UCFIE) team supported the development and ongoing research of the Quality Modular Building Task Force organized by the Hickory consortium, which includes thirteen of the nation's largest modular homebuilders. UCFIE led in research efforts involving factory design, quality systems and set & finish processes. UCFIE used research findings to assist in the analysis and design of two new modular housing factories – Excel homes, Liverpool, PA and Cardinal Homes - Wyliesburg, VA.

CONCLUSIONS

The entire BAIHP team of over 20 researchers and students are involved in a wide variety of activities to enhance the energy efficiency, indoor air quality and durability of new housing and portable classrooms.

In addition to energy efficiency, durability, health, comfort and safety BAIHP builders typically consider resource and water efficiency. For example, in Gainesville, FL BAIHP builders have incorporated the following features in developments:

- Better planned communities
- More attention given to preserving the natural environment
- Use of reclaimed sewage water for landscaping
- Use of native plants that require less water
- Storm water percolating basins to recharge the ground water
- Designated recreational areas
- Better designed and built infrastructure
- Energy efficient direct vented gas fireplaces (not smoke producing wood)

ACKNOWLEDGEMENTS

This research was sponsored, in large part, by the U.S. Department of Energy, Office of Building Technology, State and Community Programs under cooperative agreement no. DE-FC36-99GO10478 administered by the U.S. DOE Golden field office. This support does not constitute an endorsement by DOE of the views expressed in this report.

The authors appreciate the encouragement and support from George James, program manager in Washington DC and Keith Bennett, project officer in Golden CO.

Special thanks to Bert Kessler of Palm Harbor Homes, Mike Dalton of Stylecrest Sales, Mike Wade of Southern Energy Homes and David Hoak of Alten Design for the hundreds of hours they have each contributed to the success of BAIHP.

We are grateful to our sponsors, industry partners, collaborators and colleagues for this opportunity to make a difference.

REFERENCES

- Cummings, J.B., Withers, C., McIlvaine, J., Sonne, J., Fairey, P., and Lombardi, M., “Field Testing to Characterize the Airtightness and Operating Pressures of Residential Air Handlers,” FSEC-CR-1285-01, Florida Solar Energy Center, Cocoa, FL., November 30, 2001.
- FPL, 1995. “New Home Construction Research Project Findings, Results & Recommendations,” Final Report to the Florida Public Service Commission, June 1995.
- Moyer, N., Beal, D., Chasar, D., McIlvaine, J., Withers, C. and Chandra, S. “Moisture problems in manufactured housing: Probable causes and cures”, Proc. ASHRAE Indoor Air Quality 2001, Nov, 2001