

DISSERTATIONES GEOPHYSICALES UNIVERSITATIS
TARTUENSIS

6

ELECTRIC AEROSOL SPECTROMETRY

Ph. D. Thesis

by Aadu Mirme

Tartu 1994

Official opponents:

M. Aints, Ph.D. (Tartu)
A. Juozaitis, Ph.D. (Vilnius)
J. Mäkelä, Ph.D. (Helsinki)

The dissertation will be defended on December 20, 1994, at 11 am in the Council Hall of University of Tartu, Ülikooli 18, EE2400 Tartu, Estonia.

The material presented to get the academic degree of a Doctor of Philosophy in Geophysics is available at the Tartu University Library.

Secretary of the Council

H. Ohvril

Aadu Mirme is born in 1945. He graduated from St. Petersburg University in 1970. He was employed in Air Electricity Laboratory of University of Tartu as scientific worker. Now he is a scientific worker at the Department of Environmental Physics of University of Tartu.

The permanent address of the author:

Department of Environmental Physics
University of Tartu
Ülikooli 18
EE2400 Tartu
Estonia

ABSTRACT

Aerosol is a complicated component of the atmosphere, which is gaining importance with the increasing pollution of the environment.

New knowledge about the processes going on in aerosol and in the atmosphere can be obtained by studying aerosol distribution functions, the distribution of aerosol particle sizes in particular.

This paper deals with the potentials of electric methods of aerosol measurement and principles and techniques of data processing into distribution data. A combined electric method is proposed to study the distribution of atmospheric aerosol particle sizes.

Electric Aerosol Spectrometer (EAS) meeting the requirements to an instrument for atmospheric aerosol research has been worked out on the basis of this study.

The EAS measurement range is from 10 nm to 10 μm of the particle diameter. The range can be easily extended to 2 nm. EAS can work under a wide range of meteorological conditions even by 100% of humidity, and for months without any maintenance. EAS measures correctly even in heavily polluted environments characterised by rapid aerosol fluctuations.

The design of EAS takes into account the physical limitations of measurement process which enables reliable conversion of measurement data into distribution ones practically without prior determination of the type of the aerosol distribution function. Methods of full consideration of measurement errors have been developed to measure correctly a wide range of aerosols.

Calibration of an aerosol instrument is a special problem. Principles of using all kinds of information, e.g., knowledge about the aerosol and the instrument characteristics are considered for accurate calibration of EAS. The methods of full account of calibration errors are developed.

The uses of EAS in aerosol studies and methods of processing EAS measurement data are discussed. Atmospheric aerosol characteristics determined with the help of EAS measurements are reported on.

Aerosol measurement data reflect general aerosol processes, also characteristics and spatial distribution of aerosol sources. An atmospheric aerosol variability model is proposed which enables to estimate the characteristics of aerosol processes by analysing the measurement data.

A method of extracting new information by combining the aerosol distribution data with data on some other characteristics of the aerosol has been developed. As an example a study of soot distribution in aerosol particles is described.

A method of estimating the power of aerosol filters and productivity of aerosol sources is presented.

An application of EAS to studies of aerosol formation processes in size range 2 - 20 nm is reported on. Main regularities of aerosol generation by corona discharge have been established.

CONTENTS

ABSTRACT	3
CONTENTS	5
NOMENCLATURE	8
Abbreviations.....	8
Symbols	8
1 THE TASK OF AEROSOL MEASUREMENT.....	12
1.1 Role of aerosol.....	12
1.2 Aerosol characterisation	12
1.3 Measurement of particle sizes.....	14
1.4 Peculiarities of atmospheric aerosol measurements.....	17
1.5 Electric aerosol measuring instruments.....	19
2 THE AIM OF THE STUDY.....	23
3 THEORETICAL FOUNDATION OF ELECTRIC AEROSOL SPECTROMETRY.....	24
3.1 General description of the distribution measurement process	24
3.2 The main components of electric aerosol spectrometry.....	25
3.3 Charging of aerosol particles	26
3.3.1 Bipolar charging	27
3.3.2 Unipolar charging	28
3.4 Electric mobility of a charged aerosol particle	31
3.5 Analysis of electric mobility of particles	32
4 MODELLING OF ELECTRIC AEROSOL SPECTROMETER	35
4.1 Apparatus equation of electric aerosol spectrometer	35
4.2 Transformation of the information by the spectrometer.....	36
4.3 Measurable distribution functions of aerosols	37
4.4 Model of a finite-dimensional linear aerosol spectrometer.....	39
5 SPECTROMETER QUALITIES	42
5.1 Quality of charging	42
5.2 Resolution ability	44
5.3 Resolution of charging.....	45
5.4 Resolution of mobility analyser	46
5.5 Resolution of spectrometers.....	47
5.5.1 Aerosol focusing in spectrometers	48
5.6 Spectrometer sensitivity.....	49
5.6.1 Estimation of the signal-to-noise ratio	50
5.6.2 Spectrometer noise.....	51
5.6.3 Output signal of the spectrometer	51
5.6.4 Particle losses in the charger.....	51

5.6.5	Reduction of losses in the charger	52
5.6.6	Sensitivity of aerosol spectrometers.....	53
6	PRINCIPLES OF A WIDE RANGE SPECTROMETER.....	55
6.1	General principles for a wide range spectrometer.....	55
6.2	Evaluation of the wide range aerosol spectrometer.....	55
7	CONSTRUCTION PARAMETERS OF SPECTROMETER	57
7.1	General questions of spectrometer construction	57
7.2	Diffusion charger	57
7.2.1	Principle of diffusion charger construction.....	57
7.2.2	Parameters of the diffusion charger	58
7.2.2.1	Ideal wire-to-cylinder corona.....	59
7.2.2.2	Ideal point corona	59
7.2.2.3	Comparison of cylindrical and point coronas.....	61
7.3	Field chargers	62
7.3.1	Particle losses in chargers	62
7.4	Construction principles for analysers.....	62
7.4.1	Analyser dimensions.....	63
7.5	Selection of spectrometer construction parameters.....	64
8	SPECTROMETER SIGNAL PROCESSING AND SPECTRUM EVALUATION	68
8.1	Parallel measurement principle.....	68
8.2	Signal recording in aerosol spectrometry.....	69
8.3	Electrometric detector for the aerosol spectrometer	70
8.4	Processing measurement signals.....	71
8.5	Formation of the apparatus record.....	72
8.6	Evaluation of the spectrum	73
9	THE CONSTRUCTION OF AN ELECTRIC AEROSOL SPECTROMETER OF TARTU UNIVERSITY.....	75
10	METHODS OF SPECTROMETER CALIBRATION	77
10.1	Calibration task.....	77
10.2	Spectrum basis.....	77
10.2.1	Adaptation of the spectrum model to the atmospheric aerosol spectrum.....	78
10.3	Calibration methods.....	79
10.4	Theoretical calibration	79
10.5	Experimental calibration.....	80
10.5.1	Calibration with test aerosols.....	80
10.5.2	Calibration based on the analysis of particle deposit.....	82
10.5.3	Direct calibration	83
10.6	Use of information sources	84
10.7	Parametric calibration method	84

10.8 Summary of calibration methods	85
10.9 Accounting for calibration errors.....	85
11 AEROSOL STUDIES BY MEANS OF THE ELECTRIC AEROSOL SPECTROMETER.....	88
11.1 Observations of atmospheric aerosol.....	88
11.2 Analysis of aerosol distribution measurement data.....	90
11.2.1 Variations of the shape of the aerosol particle size distribution.....	90
11.2.2 Daily variations of atmospheric aerosol distribution.....	92
11.2.3 Analysis of the autocorrelation functions of the aerosol fraction concentration.....	93
11.2.4 An atmospheric aerosol variability model	94
11.2.5 Studies of the aerosol particle evolution processes.....	96
11.2.6 Application of correlation analysis to studies of aerosol composition.....	98
11.3 Studies of environment pollution.....	103
11.4 Studies of aerosol generation.....	104
12 CONCLUSIONS	107
REFERENCES	110
APPENDIX	125
1 Apparatus matrix of EAS.....	125
2 EAS record printout.....	126
3 EAS spectrum printout.....	127
ACKNOWLEDGEMENTS.....	128
RESÜMEE.....	129

NOMENCLATURE

Abbreviations

BC	Black (elementary) carbon
CNC	Condensation nuclei counter
DMPS	Differential mobility particle sizer
EAA	Electric aerosol analyser
EAS	Electric aerosol spectrometer

Symbols

a_i	Approximation coefficients
BC	Black carbon mass concentration in the air
C	Electric capacitance
C_e	Electrometric amplifier feedback capacitance
$C(l)$	Current electric capacitance of analyser at the distance l
C_m	Total effective capacitance of analyser
C_R	Factor of turbulent diffusion
D	Covariation matrix
D_d	Coefficient of turbulent diffusion
d_{ii}	Dispersion of i -th record element
$d_{h,ii}$	Dispersion of i -th element of record effected by apparatus matrix errors
$d_{\Sigma,ii}$	Total dispersion of i -th record element
E	Electric field intensity
Ei	Integral exponent function
e	Elementary charge $1.60 \cdot 10^{-19}$ C
F	Air flux in m^3/s
F_a	Aerosol flux
F_g	Clean air (gas) flux
$f(\vec{x})$	Distribution function
$G(j,k)$	Apparatus function of j -th section of the mobility analyser
H	Apparatus matrix
H_{ij}	Element of the apparatus matrix
H^j	j -th row of the apparatus matrix
$H(y,x)$	Apparatus function, the kernel of the apparatus equation
h	Width of the charging zone
I	Electric current of the flux of ions

$I_S(r)$	Electric current induced by the flux of charged particles with radius r
$I(C)$	Aerosol electric current density as a function of analyzer capacitance
$I(q,i)$	Distribution of current induced by particles with charge q on i -th section of the analyser
I_i	Electric current of i -th section
I_+, I_-	Electric current of positive and negative corona discharges, respectively
j_l	Linear ion current per unit of length
j_0	Linear current at radius R_0
K	Boltzman constant
k	Electric mobility
k_I	Electric mobility of ions
k_p	Electric mobility of particles
$k(q,r)$	Electric mobility of particle with q elementary charges and radius r
L_U	Ratio of aerosol fluxes at inlet and outlet of the unipolar charger
L_A	Length of the analyzer
l	Linear dimension of aerosol cloud
M	Number of electric field lines
N_s	Number of particles per second
$N(r)$	Density function of aerosol cumulative distribution
N_i	Aerosol number concentration in i -th fraction
n	Ion concentration
$n(q,r)$	Concentration of particles with radius r and q elementary charges
n_0	Number of zero readings
n_m	Number of signal readings
$P(q,r)$	Probability of particle with radius r to have q elementary charges
P_i	Particle generation power of aerosol source in i -th fraction
P_p	Particle generation power
P_v	Vapor generation power
p_+	Probability of particle to have positive charge
$Q(t)$	Particle generation power density function
\underline{q}	Electric charge in elementary charges
\bar{q}	Mean electric charge in elementary charges
R	Radius
R_0	Outer radius of charger
R_A	Mean radius of analyzer

ΔR_A	Distance between analyzer electrodes
R_e	Electrometric amplifier feedback resistance
$R_n(\tau)$	Autocorrelation function of aerosol
$R_Q(\tau)$	Autocorrelation function of aerosol source
r, r'	Radius and corrected radius of particle
r_i, r_{i+1}	Margins of i -th fraction
S_A	Surface of cross-section of the analyser
T	Absolute temperature in $^{\circ}\text{K}$
T_a	Aerosol residence time, aerosol time constant
T_i	Time interval between $(i-1)$ -th and i -th readings
T_c	Aerosol relaxation time in chamber
t	Time
t_q	Charging time of particles
t_c	Aerosol cloud registration time
U	Electric potential, electric voltage
U_e	Output signal of electrometric amplifier
$U_{e,f}$	Restored signal of electrometric amplifier
U_{est}	Estimated useful signal of electrometric amplifier
V_F	Linear velocity of air
V_c	Volume of aerosol chamber
V	Covariation matrix of aerosol spectrum
V^j	Covariation matrix of j -th row of apparatus matrix
v	Wind linear velocity
$()_A$	An analyser parameter
$()_B$	A parameter of bipolar charging
$()_D$	A parameter of diffusion charging
$()_E$	A parameter of field charging
$()_e$	An electrometer parameter
$()_S$	A spectrometer parameter
$()^T$	Transposing of matrix
$()_U$	Parameter of unipolar charging
α	Charging parameter
$\beta(r)$	Black carbon mass in aerosol particle with radius r
β_i	Mass of black carbon in aerosol particle of i -th fraction
$\Delta(y)$	Error function of apparatus record
Δ_i	Error of i -th apparatus record element
δ	Resolution
$\delta k/(r_1, r_2)$	Resolution of particles with radii r_1 and r_2 on the scale of mobility
ε	Relative dielectric permeability of particles
ε_0	Dielectric permeability of vacuum
ζ_W	Sensitivity of wide range spectrometer
η	Viscosity of the air

η_i	Cleaning power of filter in i -th aerosol fraction in m_3/s
Θ	Nonhomogeneity of electric field
λ	Electric conductivity
σ	Standard deviation
$\sigma_{k/r}$	Standard deviation of electric mobility distribution in case of fixed r
σ_C	Standard deviation of deposition capacitance
τ_e	Integration constant of electrometric amplifier
τ_a	Correlation time of aerosol concentration at measurement site
Φ	General spectra matrix
$\varphi(x)$	Aerosol spectrum function
φ	Aerosol spectrum vector
$\varphi^j(x)$	Distribution function of j -th elementary spectrum
φ_j	Concentration of j -th elementary spectrum
χ	Quality parameter
Ψ	General record matrix
Ψ^j	Record vector composed of record elements of j -th channel
ψ	Apparatus record vector
$\psi(y)$	Apparatus record function of spectrometer
ψ_i	i -th element of spectrometer record
ω	Radian frequency

1 THE TASK OF AEROSOL MEASUREMENT

1.1 Role of aerosol

Aerosol is defined as a mixture of gaseous environment - the air and solid or liquid particles suspended in it [Fuchs 1964]. According to this, the ambient air is always an aerosol because it always contains some amount of particles.

Particles are generated into the air as a result of many natural processes, moreover by human activity. Well-known natural sources of aerosol are volcanoes also the world ocean and vegetation. Most of human produced aerosol originates from combustion. Thermal power plants, furnaces and internal combustion engines are productive sources of aerosol.

Aerosols are of great importance to human beings just because people spend their whole life surrounded by the air, i.e., in an aerosol environment.

People usually become aware of aerosols by their specific effect, caused by constituent particles. For example, most of the inhaled aerosol particles deposit in the human respiratory organs and, in one way or other have an effect on health.

In the natural environment, aerosols have a very strong influence on the climate. The propagation and absorption of solar radiation in the atmosphere directly depend on aerosols. The water cycles through the aerosol phase. Pollen of plants, as well as viruses and bacteria spread as aerosol particles. Aerosols have come to be used in medicine and many other fields. They are used in numerous technological processes, but they can also be harmful as pollutants.

Pollution of the environment is the biggest problem mankind is facing today. Polluting substances in the atmosphere can be in the form of gases as well as particles. The latter may be emitted into the air, they may also originate from chemical reactions of gaseous substances or other processes of the atmosphere.

As chemical composition as well as physical behaviour of aerosol particles differ from those of gaseous pollutants the polluting effects are also different [Jaenicke 1990] and call for special study of aerosols.

1.2 Aerosol characterisation

From the physical point of view an aerosol is a complicated non-equilibrium system of gaseous, solid and liquid substances with active in-

teraction between the components. A full description of an aerosol is practically impossible, so simplifications are inevitable.

The first simplification is that only particles are regarded as aerosol. The gaseous environment is neglected. As to environmental properties then only the ones considered of vital importance for certain study are taken into account, the others are ignored. For example, when describing particle movement, only the resistance of environment is considered, when describing aerosol vaporisation and condensation, only vapour concentration is taken into account, etc. The rest of the environment is treated as being passive, something like "world ether" known in the history of science. Some important characteristics of the environment may be missed as a result.

As far as the unique effect of an aerosol can be characterised by the value of a single parameter, the minimal description of aerosol may be expressed through one parameter only. It can be the amount of some integral characteristic in one unit of volume, i.e., concentration. For example, it can be the concentration of a polluting substance. The number and mass concentrations of particles are widely used to characterize the aerosols.

The number concentration of particles is used as a measure of cleanness in work rooms in advanced technologies. A number of instruments of different types have been designed to measure the particle number concentration.

In environmental studies the atmospheric aerosol is measured by determining the total mass concentration of particles in the air.

These aerosol descriptions are not too precise because usually the effect of aerosol is not directly characterised by the parameter measured. The effect can be adequately measured only by an instrument measuring just the effect. As there are a great variety of effects, a variety of special instruments are needed. The task can be simplified by measuring a limited set of general characteristics of the aerosol providing the most basic description. The concrete characteristics of the aerosol can be estimated by model calculation methods.

Aerosol particles having originated under a variety of conditions and having different histories, display different physical properties and chemical compositions. For example, the size, density, shape, electric charge, dielectric permeability, etc., are important physical properties determining the behaviour of particles. They as well as a variety of other properties should be included in aerosol description.

Theoretically aerosols can be described by multidimensional distribution functions of particle concentration [Friedlander 1970, 1971, Voloshshuk, Sedunov 1975]. Practically this can be accomplished by simultaneous measurement of aerosol particle distribution according to several parameters.

One of the basic distribution functions is the size distribution of particle concentration, as a number of essential properties of aerosol such as the mechanical kinetic properties as well as its optical and electrical characteristics depend on the aerosol particle sizes. The distribution of aerosol other characteristics can be described in relation to particle size distribution [Heintzenberg and Covest 1990].

Aerosol size distribution can be evaluated statistically by classifying particles according to their sizes and by measuring particle concentrations inside the classes. For that we shall have to be able to characterise the particle size.

1.3 Measurement of particle sizes

Aerosol particles range from particles consisting of a few molecules barely different from gas molecules (10^{-9} m) to large lumps still dispersible in the air (10^{-3} m). The largest size of particles of interest in aerosol studies can be estimated at tens of micrometers (10^{-5} m), the bigger particles having only short-lasting effect on aerosol.

There is a large instrumentarium designed to measure the size of aerosol particles. The instruments, many commercially available, use a variety of measurement methods. Methods and instruments for aerosol particle size measurement have been discussed in a number of papers [Davies 1974, Jaenicke 1976, Fuchs 1986, Sinclair 1986, Pui and Liu 1988, Schmitt-Ott 1991, etc.]. There is a good survey of the question given by Keskinen (1992). A recent book on the issue is the one edited by Willeke (1992).

Methods used to measure aerosol particles have different capacities of characterising the particle sizes (Table 1) [Tamm 1986]. Also a number of other properties of methods are important for aerosol measurements.

Particle size is usually determined indirectly, by means of a physical phenomenon when the response of relevant instrument depends on particle size. The particle size is estimated by comparing the readings of the instrument with the instrument calibration data.

Particle size measurements are affected by two physical factors: the length of gas molecule free path - a line separating the continuous and discrete description models of the environment - and the wave length of

light. These two factors restrict most measuring technique capacities, although the range of aerosol particle sizes is more extensive, in fact.

Table 1. Aerosol particle measurement methods and their measurement range.

Measurement method	Particle diameter (nm)				
	1	10	100	10 ³	10 ⁴
Diffusion	----	+++	+++	+++	+++ +
Electric, bipolar	----	----	++	+++	+++ +--
Electric, diffusion	---+	+++	+++	+++	+++ +-
Electric, field				+++	+++ +++ +- --
Electron microscopy	++	+++	+++	+++	+++ +++ +++ +++ ----
Optical microscopy					--+++ +++ ++
Photoelectric counter				---	+++ +++ +++ +++ ++
Ultramicroscopic trajectory				---	+++ +++ +++ --
Inertial impacts			---	+++	+++ +++ +++ +++ +++
Aerodynamic sizing				+++++	+++ +++ +

Optical microscopy could be considered a rather direct method of particle size measurement, but it can be used to measure large particles only. Electron microscopy can be used to examine the whole range of particle sizes but it requires special pre-treatment of particles.

Microscopy is a method of study in which each particle is measured separately [Tamm 1975]. The method of ultramicroscopic tracing of particle trajectories [Fuchs 1964, Tamm and Fischer 1973] and optical counting of particles fall into the same class. These methods are extremely sensitive to particle concentration.

There is another class of measuring techniques that are not able to measure individual particles but particle groups. The impactor techniques and electric methods belong to that class. These methods are less sensitive than the methods measuring each particle separately. On the other hand, as the response of the instrument is the result of total effect

of many particles the methods are good for measuring high aerosol concentrations. Also the results are of high statistical representativity for the aerosol.

An important characteristic of a method is the time spent on data processing. If we take microscopy or impactor methods, we must remember that they involve a long examination and analysis of directly obtained samples. It enables to repeatedly analyse different characteristics of a sample. However, it is time and labour consuming.

Many methods can affect the particle size depending on particle composition. Microscopy or electron microscopy is not the best choice for measuring liquid or easily vaporising particles. Impactors and other instruments may bring about changes in particle size induced by changes in the air pressure [Biswas *et al.* 1987].

The measurement result depends not only on the actual size of the particle but also on other properties of the particle. The electric charge of particles used as a working parameter in electric methods, depends on particle conductivity. Extinction of light in the particle population depends on the optical properties of particle material effecting errors in optical instruments. A scintillation method [Binek 1961] using light emission of particle matter is an example of the effect of particle substance on size measurement.

Particle size measurement methods are sensitive to the shape of particles. As aerosol particles are seldom spherical and smooth surfaced, the effect of the shape is to be taken into account when considering the results.

Thus, no actual size of a particle can be measured. Each method results in measuring the effective size specific for the method. There are effective optical, diffusion, aerodynamic, etc., sizes [Keskinen 1992]. They differ from each other and can coincide only in a special, ideal case.

The effective size can be correct enough to characterize the phenomena of the same field. For example, the aerodynamic size of particles could be the measurement of choice, when studying the mechanics of particles, as it includes also the shape and other essential properties of the particles.

1.4 Peculiarities of atmospheric aerosol measurements

Almost all aerosol measuring devices have been used in measuring atmospheric aerosol.

Some integral characteristics of atmospheric aerosols, such as total mass concentration, have been measured rather systematically. The aerosol size distribution of large particles has been measured with optical counters, that of medium size particles has been measured with impacts. The total number concentration of small particles has been measured with condensation particle counters. Diffusion batteries have been used to estimate aerosol distribution. Whitby and his colleagues (1969) introduced an electric method into atmospheric aerosol studies. A discussion of instrumentation for atmospheric aerosol measurement was presented by Pui and Liu (1988).

Aerosol at different size ranges of particles is responsible for different effects in the atmosphere. Particles are generated into the range of small particles. Most of the aerosol mass is in the range of micrometers. The maximum values of aerosol surface concentration are in submicron range. As they all are important characteristics of atmospheric aerosol in different processes, all the size ranges should be measured.

There is no aerosol instrument capable to measure the full range of atmospheric aerosol particle sizes. To gain a full picture, the data of different instruments, for example, electric analyser and optical counter must be combined. The result is usually poor, as the data of different instruments do not match.

The variability of atmospheric aerosol, an important source of information, has not found due attention yet. On the one hand, variability provides information about fundamental processes in the aerosol. On the other hand, variability is the result of spatial nonhomogeneity of the aerosol, effected by the location of aerosol sources, aerosol transport processes and turbulence of the air. This is information about environmental pollution processes. Most of the available instruments fail to measure rapid changes in aerosol concentration and register the aerosol variability in the atmosphere.

To be able to analyse statistical regularities of the processes in the natural atmosphere one needs a large number of measurements effected over long periods of time. Jaenicke in his paper(1984) points out that thousands of measurements are needed to be able even to calculate statistically significant mean characteristics of aerosol.

In the atmosphere water vapour and other components are active in particle formation. As the changes in environmental conditions induce change in particle characteristics, the characteristics of particles may change considerably during the measurement [Biswas *et al.* 1987].

As the measurements are to be carried out in the natural atmosphere, also various, sometimes hard meteorological conditions have to be taken into account.

To be able to measure adequately in these conditions, an instrument measuring atmospheric aerosol must meet a number of requirements. It should measure:

- the size distribution of aerosol particle concentration and some other characteristics if possible;
- a wide range of particle sizes (at least from 10 nm to 10 μm);
- the particle size, effective in atmospheric processes, the effective size of the same type in the full measurement range.

The instrument must have:

- sufficient sensitivity for measuring atmospheric aerosol;
- a wide range of measurable concentrations (dynamic range);
- sufficient resolution of particle sizes;
- good time resolution to follow fluctuations of atmospheric aerosol.

The instrument must be:

- weatherproof;
- geared for observations over long periods;
- geared for on-line measuring;
- easily maintainable.

Practically none of the measuring methods has provided an instrument well enough to meet these requirements, as they are not effective in such a wide range of sizes. Many methods have time resolutions too low to be able to follow changes in the aerosol concentration (impactor method). Electron microscopy, practically the only method covering the whole range of sizes, imposes too radical changes on the environmental conditions of the particles as well as it is difficult to relate the electron microscopical size of particles to the particle size effective in natural aerosol processes.

However, the full size range can be covered by combining several methods, provided the similar effective size types. Several combinations can be suggested (e.g., diffusion method with an inertial or aerodynamic method), but a combination of electric methods seems to be the most effective for the purpose.

Electric methods using the electric charging of particles, do not impose much change on the properties of particles during the measurement as

charged particles are natural in the atmosphere. Electric mobility is well related to mechanical mobility and so the effective sizes of particles.

As the methods are based on electric phenomena, the well-developed technique of recording electric signals, can be used. The electric methods can have a high measurement rate ensuring time resolution and can be well automated for long periods of observations.

1.5 Electric aerosol measuring instruments

Electric methods are based on using electric charges of particles. The particle electric charge makes it possible to act on the particle with electric field. The whole process can be described by well-developed electrodynamic theory. The particle can be detected by measuring the electric charge.

As natural aerosol is always charged to some extent, it can be assumed the additional charging does not essentially change the other characteristics of particles.

Most of air ions are actually charged particles and consequently air ionisation and ion measurements can be considered aerosol characterisation, the difference often being in the way of result presentation. The mobility spectrum of ions can be regarded as a distribution of aerosol charge concentration according to the electric mobility of particles. The number concentrations of particles can be calculated on this basis, provided some assumptions are added [Jakobson *et al.* 1975].

In the sense of ion measurements the electric measurements of aerosol started as early as in the 19th century [Zeleny 1901]. Electric charges were purposely used in aerosol measurements by Rohman (1923).

There is a large number of experimental and theoretical studies on the regularities of aerosol charging, e.g., Pautheneir (1932), Fuchs (1947), Hewitt (1957), Brock (1970) and many others. Special credits for introducing electric measuring of aerosol should be given to Whitby and his colleagues [Whitby and Clark 1966, etc.]. Their famous Electric Aerosol Analyser (EAA) was produced commercially and it is still in use all over the world [Liu *et al.* 1976]. By now there are about hundreds of aerosol measuring devices designed after EAA.

Any electric aerosol measuring instrument consists of three essential components: aerosol charger, mobility analyser and particle detector (Fig. 1).

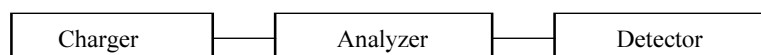

Fig. 1 The principal components of an electric aerosol instrument.

Aerosol charging is to ensure a well-determined functional correspondence between the electrical charges of particles (and electric mobility) and their sizes [Tamm 1975]. In this way, particle size measurement is transformed into the measurement of ion characteristics. The sizes of particles are found mathematically, using an inverse transformation.

There is no charger in the instruments for air ion measurements [Matisen *et al.* 1992]. Particles acquire charges in the outer environment, before entering the device. These devices can measure aerosol particle size distribution provided the size distribution of particle charges is known (in practice the particles are assumed to have an equilibrium bipolar charge distribution). In fact, these devices can be treated as aerosol devices with an external charger.

As the conditions of particle charging in outer environment are poorly determined, a special charger can be used [Tamm 1988]. An external aerosol neutraliser is actually a charger, but aerosol instruments with built-in chargers predominate.

The simplest way of charging particles is with a source of bipolar ions (usually a radioactivity based ioniser), which seems to be the best studied charging process with the lowest dependence on the electric properties of particle [Liu, Pui 1974, Liu *et al.* 1982, Liu, Gentry 1982, Vijayakumar and Whitby 1984].

Charging in the strong electric field is a relatively well defined process [Pauthenier and Moreau-Hanot 1932]. The charger designed by Hewitt seems to have the utmost characteristics [Hewitt 1957]. Problems of field charging have been generalised somewhat later [Jantunen and Reist 1983]. Field charging is not widely used probably because in comparison with optical methods it measures the same size range but it is less sensitive. Moreover, its charging characteristics are not suitable for measuring polydispersed aerosol with a wide size distribution.

Whitby and his colleagues started to use a diffusion charger [Whitby *et al.* 1965, 1966]. The effective working range of diffusion charging is that of small particles and was the leading charging method in this range. The most famous theory of diffusion charging is the one proposed by Fuchs (1947).

Bipolar charging has again come into use [DMPS of TSI, Ulevic`ius *et al.* 1988, Winklmayr *et al.* 1991]. The lower sensitivity of this method calls for a more sensitive and therefore more complicated signal detector. A method of optical particle counting is used for the purpose.

The analyser separates ions according to their electrical mobility. Applied to aerosol particles, it means a rough selection according to particle sizes. The theory of mobility analysers has been thoroughly studied in relevance to ion mobility measurement technique [Tamm 1970]. The typical analyser for an aerosol device was worked out by Hewitt (1957).

The analyser is sometimes used only with the aim of correcting the aerosol distribution in order to have special characteristics, as it is the case with devices measuring total aerosol concentration, e.g., dustmeters [Podolskii *et al.* 1972] calibrated in units of mass [Popov *et al.* 1976]. The accuracy of their measurement of aerosol mass can depend on the aerosol particle distribution pattern.

Of several possible ways of particle recording the measurement of the charge of each particle separately should be the best way. Unfortunately it can be made only by the ultramicroscopic trajectory method which determines the particle size by measuring the speed of the particle gravitational falling, electric phenomena giving extra information on the charge distribution of the particles. This is one of the few methods enabling to make one step further in aerosol study and to measure the two-dimensional distribution of particles (size and charge) [Tamm and Fischer 1973, Fischer and Tamm 1974].

The easiest method of particle detection is to measure the electric current initiated by the charges of the particles deposited in a filter of conductive material [EAA], a nonconductive filter placed into a Faraday cup is equivalent to a conductive one.

Another way of measuring the charge of particles is to deposit them on an electrode and measure the induced current of the electrode. This method is widely used in ionmeters [Tamm 1970]. This is less complicated than the filter technique, but it requires highly stable electric field to deposit the particles. Errors are likely when the removal of particles from the electrode happens or the charge of a particle cannot move to the electrode because of insufficient contact. These problems can be avoided if the aerosol charge is measured using a so called induction method [Podolskii 1976]. By this method, the aerosol flows through a device similar to a Faraday cup and the induced current is measured. The method differs from the collecting of particles in a filter, in the respect that the particles are not deposited and remain in the aerosol. In practice the charged aerosol flow is modulated, for example by varying the charging. The advantage of this method lies in the fact that the device does not change the structure of the aerosol, except some losses of the particles and the charging.

There is also a nonelectric way of particle recording with a condensation nuclei counter (CNC). It can be related to optical methods as optical counting of particles takes place. Particles of the sub-optical range are magnified to the detectable sizes by condensing vapour on their surface. This method is very sensitive and it is widely used to control the cleanliness of work rooms in high technology. However, this method is quite complicated involving a number of different techniques. The accuracy of measurement is influenced by the vapour condensation being dependant on the particle size and composition leading to a diminished accuracy of measurement in the small particle range. The dependence can be used for studying particle sizes in this range, provided the effect of the particle substance is known.

Simultaneous registration of the electric current induced by the particle flow and the number concentration of particles makes a two-dimensional particle distribution (size and charge) determination possible [Kascheev *et al.* 1991].

Attempts have been made to combine good aspects of different methods. So an impactor technique, where particles are classified according to the size by forces of inertia was combined with an electric method [Keskinen *et al.* 1992], the induced electric current was used to calculate the concentration of particles. The method is complicated but the instrument is one of a few instruments making parallel simultaneous measurements of the aerosol distribution in the whole range of particle sizes possible. The apparatus can provide also information concerning the chemical and other properties of the aerosol by analyses of the particle deposit on the impactor plates.

The output signal of a measuring device is far from being the estimate of the aerosol size distribution. To determine the particle size distribution it is necessary to take the direct measurement data through several intermediate transformations. The correct distribution can be calculated by special, complicated mathematical procedures, such as the well-known Hoppel algorithm Hoppel 1978]. Simplification of the procedure may result in significant systematic errors in the measurement results [Noppel 1990].

2. THE AIM OF THE STUDY

Aerosol, being an important component of the environment is still scantily studied. Size distribution of aerosol particle concentration is measured by electric methods but their potential abilities for atmospheric aerosol measurements have not been fully discussed yet. This thesis deals with the development of electric methods of special relevance to atmospheric aerosol. The aim is to promote atmospheric aerosol studies by the purposive development of a special aerosol spectrometer.

For the purpose, spectrometry potentials in aerosol particle size distribution measurements are studied and the principles of designing an instrument specially adapted for atmospheric aerosol measurements are worked out.

The discussion is based on the qualitative physical presentation of the problem and so to cover a wide range of topics pertaining to designing an aerosol spectrometer.

Models of electric methods are discussed. The models are evaluated on the basis of the principles of converting raw measurement data into the distribution data. The analysis of the models enables to determine the physical limits of the methods and the ways of improving most vital characteristics of an instrument such as sensitivity and effective measurement range.

Methods of selection of a spectrometer optimal construction are discussed. As the study is aimed at a thorough discussion of the principles of the spectrometry design, less attention is given to mathematically correct modelling. The necessary degree of accuracy is achieved by appropriate signal processing and spectrometer calibration.

Spectrometer calibration is considered essential part of spectrometer designing process. The calibration methods, also the methods of account of calibration errors are discussed with the main attention given to the problems of using the available information on aerosol and aerosol processes, to build an aerosol measuring instrument, which, in its turn will serve the purpose of collecting new information.

The complexity and specificity of spectrometer data call for special discussion of methods of interpretation of aerosol distribution measurements. Several methods of extracting the knowledge on aerosol processes by studying the peculiarities of aerosol distribution time series are presented.

3. THEORETICAL FOUNDATION OF ELECTRIC AEROSOL SPECTROMETRY

The process of measuring the distribution as any other measurement process, is the transformation of the information about the object under study into a form that can be recognised by man. The transformation can be conducted by a measuring instrument within certain limits only. Full consideration of the process is necessary for designing a good instrument.

3.1 General description of the distribution measurement process

The term spectrometry is widely used to denote the process of measuring the distributions of parameters of physical objects. Therefore aerosol distribution measurements can be referred to as aerosol spectrometry and the instrument as a spectrometer.

We assume that the spectrometer response is proportional to the aerosol concentration and a linear model can be used.

Information transformation effected by a linear spectrometer can be presented by an apparatus equation [Tammiet 1975] describing the response of an instrument to a certain property of the measurement object:

$$\psi(y) = \int_{\mathcal{R}} H(y, x) f(x) dx + \Delta(y). \quad (3.1)$$

Here $\psi(y)$ denotes the output signal of the spectrometer (hereafter being referred to as the apparatus record). $f(x)$ is the distribution function. x is the argument of the distribution function and y is the argument of the apparatus record. Transformation errors are described by the random function $\Delta(y)$. The characteristics of the spectrometer and the process of measuring are described by an apparatus function $H(y, x)$ also referred to as the response function of the instrument because the output signal of the spectrometer or its response to the distribution described by the delta-function $\delta(x - x_0)$ is equal to $H(y, x_0)$.

The distribution argument x applied to aerosols may be the radius of a particle (r). The record argument can be the electric mobility of the particle.

Equation (3.1) describes the transformation made by a physical instrument. The measurement ψ is directly recorded by the instrument. It can be treated as the distribution immediately given by the instrument. It differs from the required form just by the transformation mathematically described by Equation (3.1).

To find the required distribution it is necessary to perform a mathematical information transformation in the opposite direction from the transformation made by the measuring device, in other words, to solve Equation (3.1) regarding distribution function f . This is the inverse transformation of spectrometry.

The quality of the inverse transformation which determines the precision of a measurement, depends on the characteristics of the apparatus expressed in the apparatus function and apparatus record as well as on the required form of the distribution function.

By spectrometer designing a certain freedom is allowed in choosing the record argument and the form of the spectrometer record function as well as the type of the distribution function, provided the convertibility of a measurement into the required distribution.

3.2 The main components of electric aerosol spectrometry

Electric aerosol spectrometry based on the principles of the electrical method of aerosol measurement and measurement data processing, can be presented as taking place in a hierarchy of graded steps.

The variability of aerosol characteristics depending on conditions, can affect the accuracy of particle size measurement. The variation of the distribution of the initial electric charges on the particles before the measurement, is the most disturbing factor for the electric method. The preliminary charge distribution of particles as well as other initial conditions of a measurement are made stable by conditioning. Aerosol is usually set to the standard bipolar equilibrium charge distribution by a high density bipolar ion field generated by a source of radioactivity.

Conditioning aerosol

Charging of aerosol

Analysis of electric mobility

Detection of aerosol signals

Any electric aerosol measuring instrument uses charges of particles for the purpose. Particle charging is the first essential transformation of aerosol in which the directly unmeasurable particle size distribution is converted into the measurable distribution of particle electric mobility.

A mobility analyser is to analyse the aerosol electric mobility distribution. The output signal of the analyser is in the form of a set of aerosol particle groups of different electric mobility.

Information about the particle concentration is detected in the form of some kind of signals. They are the raw measurement data to be turned

into the spectrometer record.

Preliminary data processing

The first, direct stage of measuring a distribution ends with the apparatus record. The raw data are purified from errors and distortions of the instrument as well as measurement process, and the precision level of the record elements is estimated.

Evaluation of aerosol distribution

The last stage of aerosol measurement is an aerosol distribution evaluation, made by solving the apparatus equation in regard to the apparatus record. The apparatus record is a recognisable form of information reflecting the aerosol distribution property after a number of direct measurement transformations mathematically described by apparatus Equation (3.1). To be presented in the form of required (recognisable) distribution data, the data must undergo reverse transformation performed by solving Equation 3.1.

The first four stages can be carried out by special instrumentarium, the last two stages can be performed by computing.

Let us go now into the discussion of the aerosol transformations in an electric aerosol spectrometer.

3.3 Charging of aerosol particles

Charging of particles is the first principal transformation of aerosol in an electric aerosol spectrometer. There are several ways of particle charging, but mostly charging by attaching small air ions to particles is preferred.

As ion attaching is a common process in atmospheric aerosol, it does not bring about any significant extra change in the particles when performed by an apparatus.

The dependence of the particle charge obtained in ionic environment on the properties of the environment and the properties of the particle, has been discussed in many papers [Pautheneir 1932, Fuchs 1964, Brock 1970, etc.]. We will discuss the basic regularities here.

Depending on the environmental conditions the charging can be classified as bipolar or unipolar charging, as charging in a strong electric field or without an electric field.

3.3.1 Bipolar charging

The standard bipolar ionic environment is the environment where the concentrations of the ions of the opposite signs are in the equilibrium

and the electric field is absent. Then if the particle residence time is long enough [Takahashi 1971], the stationary situation is achieved and the particle charge distribution follows Boltzmann's law [Noppel 1982a]:

$$n(q, r) = n(0, r) \exp\left(-\frac{q^2 e^2}{8 \pi \epsilon_0 r K T}\right). \quad (3.2)$$

Here $n(q, r)$ is the concentration of the particles with radius r and q elementary charges, q is the electric charge in elementary charges, e is the elementary electric charge, K is the Boltzmann constant, T is absolute temperature and ϵ_0 is the dielectric permeability of vacuum.

The distribution deviations of small particles can be corrected if in Equation (3.2) the particle radius r is replaced by corrected radius r' [Kojima, 1978]:

$$r' = r \left(1 + \exp\left(-\frac{r^2}{1.4 \cdot 10^{-12}}\right)\right). \quad (3.3)$$

Radii r and r' are expressed in centimetres.

The mean electric charge of a particle \bar{q}_B is

$$\bar{q}_B = 0 \quad (3.4)$$

and the half width of the charge distribution σ_B is

$$\sigma_B = \frac{1}{e} \sqrt{4 \pi \epsilon_0 r K T}. \quad (3.5)$$

In electric spectrometry usually only the particles with one sign of charges are analysed, the others are removed. The corresponding statistical values can be calculated directly as

$$\bar{q}_{+B} = \frac{\sum_{q=1}^{\infty} q n(q, r)}{\sum_{q=1}^{\infty} n(q, r)}, \quad (3.6)$$

$$\sigma_{+B} = \sqrt{\frac{\sum_{q=1}^{\infty} (q - \overline{q_{+B}})^2 n(q, r)}{\sum_{q=1}^{\infty} n(q, r)}} \quad (3.7)$$

3.3.2 Unipolar charging

In the unipolar environment the stationary distribution of particle charges does not exist. The charge distribution can be found by integrating the charge flux to particle in time [Fuchs 1947, Mirzabekyan 1966, Noppel 1982a, 1985]. Charging in different conditions has been studied by Liu *et al* (1967), Liu *et al.* (1977), Liu and Capadia (1978) and Pui *et al.* (1988). Special approximation formulas have been worked out by Noppel (1983, 1985a).

There are two mechanisms for an ion to reach the particle: the chaotic motion and the forced motion in the electric field. Respectively, charging can be considered to be a combination of two processes; pure diffusion charging (the chaotic motion of ions is considered) and pure electric field charging (ions moving strictly in the direction determined by the field) [Mirzabekyan 1969].

According to Mirzabekyan the superposition of charging processes with an error below 20% can be considered linear and the total charge of the particle can be calculated as a sum of the charges of the processes:

$$\overline{q_U} = q_D + q_E \quad (3.8)$$

The charge obtained in diffusion charging q_D can be calculated as

$$\frac{\varepsilon_0}{ek} \frac{q_D e}{4\pi\varepsilon_0 rKT} \ln \frac{q_D e}{4\pi\varepsilon_0 rKT} \cdot 5.772 \cdot n t_q \quad (3.9)$$

Here k is the electric mobility of ions, Ei is the integral exponent function, n is the concentration of the ions and t_q is the charging time.

The charge of the electric field q_E is calculated after The equation [Rohman 1923, Pautheneir 1932]:

$$q_E = \frac{4\pi\varepsilon_0}{e} + 2 \frac{\varepsilon - 1}{\varepsilon + 2} \frac{\pi k e n t_q}{4\pi\varepsilon_0 + \pi k e n t_q} \quad (3.10)$$

Here ε is the relative dielectric permeability of the particle, n and E are the ion density and the density of the electric field of the environment respectively.

As it results from the paper by Noppel and Peil (1986), the width of charge distribution of unipolar charging is nearly equal to that of bipolar charging. The half width of the distribution in diffusion charging can be estimated as

$$\sigma_D \approx \sigma_B \quad (3.11)$$

and the same for field charging as [Emets *et al.* 1993]:

$$\sigma_E \approx \sigma_{BE} = \frac{\sqrt{\frac{3\varepsilon}{\varepsilon+2} \frac{4\pi\varepsilon_0 E r \cdot r}{e}}}{2} . \quad (3.12)$$

Proceeding from the linear superposition of charges (Eq. 3.8) the half width of the total charge distribution can be estimated as

$$\sigma_U = \sqrt{\sigma_D^2 + \sigma_E^2} . \quad (3.13)$$

As the ion mobility k depends on the concentration of gaseous and vapour impurities in the atmosphere [Parts 1988, 1990], it is practical to restructure The equations. As follows from The equations and proved in practice [Kirsh and Zagnitko 1980] particle charging depends on ion mobility and on ion density over air conductivity λ only:

$$\lambda = ken . \quad (3.14)$$

Tammet has introduced a charging parameter α [Tammet 1980b, 1992a]:

$$\alpha = \frac{1}{\varepsilon_0} \int_0^{t_q} dt \quad (3.15)$$

and has defined the characteristic sizes of charging as

$$d_D = \frac{e^2}{2\pi\varepsilon_0 KT} , \quad d_E = \sqrt{\frac{\alpha}{\omega E} \frac{e}{2\pi\varepsilon_0}} . \quad (3.16)$$

Here the dependence of the charge value on the particle dielectric permeability is denoted as

$$\omega = \frac{1}{2} + \frac{\varepsilon - 1}{\varepsilon + 2} . \quad (3.17)$$

Equation (3.9) can be written in this case as

$$\sum_{m=1}^{\infty} \frac{A^m}{m \cdot m!} = \alpha , \quad (3.18)$$

where the particle charge can be calculated from the formula

$$A = \frac{q_D e}{4 \pi \varepsilon_0 r K T} . \quad (3.19)$$

A can be treated as the relaxation coefficient of diffusion charging.

The mean charge of unipolar charging (Eq. 3.8) can be now expressed by the formula

$$\bar{q}_U = A \frac{d}{d_D} + \frac{\alpha}{1 + 4/\alpha} \frac{d}{U_E} . \quad (3.20)$$

We can conclude that in the first approximation, the charge of a particle is determined by the size of the particle on the one hand and by the effective charging parameter α and by the electric field density E , on the other hand. The dielectric permeability of particles is also of some subsidiary importance.

The average charge of particles calculated by formula (3.20) can be less than one elementary charge indicating a great number of particles left uncharged. However to calculate the mean electric mobility of particles, only the charged particles should be only considered. This can be achieved by the correction formulae proposed by Tammet:

$$q = \sqrt{1 + \bar{q}^2} . \quad (3.21)$$

The formulae (3.6, 3.7, 3.18 and 3.13) describe the transformation of the information pertaining to particle size, into the form of particle electric charge.

As particle charge is difficult to measure directly, indirect measuring techniques are in use. One of them measures the charge of a particle group (EAA). Another measures particle electric mobility to estimate the particle characteristics (DMPS with CNC). Both approaches start with the analysis of particle electric mobility.

3.4 Electric mobility of a charged aerosol particle

When an electric field is applied to charged aerosol particles they will start moving in the direction of the field. In the wide range the speed of particles is the linear function of the electric field density. The electric mobility of a particle is defined as the speed of the particle caused by an electric field with a unit density [Fuchs 1964].

The dependence of the electric mobility on the particle size and charge is one of the most precisely studied topics in aerosol physics. It is well described by the Stokes-Gunningham modification of the Millican equation in the range of particles down to sizes of about 10 nm:

$$k(r, q) = \frac{q e}{6 \pi \eta r} \frac{l}{r} + B e^{-C \frac{r}{l}} \quad (3.22)$$

Here q is the number of elementary charges on the particle, r is the radius of the particle, η is the viscosity of air and

$$l = 95.5 \text{ nm}, A = .864, B = .29 \text{ and } C = 1.25.$$

The size range can be extended down to few nanometers if the sum of the radii of the particle and of the gas molecule is considered as radius r here [Tammet 1992b]:

$$r = r_p + r_d, \quad r_d = 0.366 \text{ nm} . \quad (3.23)$$

Equation (3.22) makes it easy to estimate the electric mobility of particles, charged in different types of chargers, the mean mobility demonstrating different dependence on the particle size (Figure 2).

In the range of small sizes the dependence is strong in all chargings. Bipolar charging has good dependence also in other ranges, only the particle electric mobility becomes very small.

A characteristic of unipolar charging is the mobility having a minimum inside the particle size range of interest. Only in the ideal case of absolute diffusion charging, when the electric field is ignored, there is no minimum but a very low dependence of the mobility on particle size. In the case of absolute field charging (the diffusion component is ignored) the curve is similar to that of normal field charging with a lower intention of the curve only.

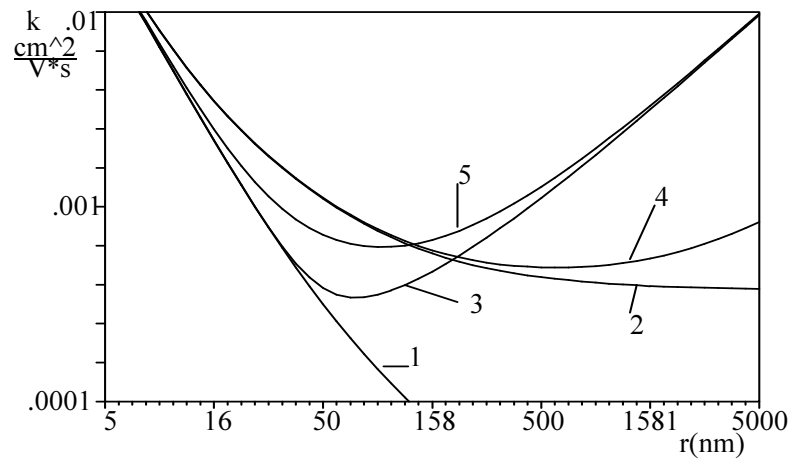

Fig.2. Mobilities of particles of different chargings vs. particle size
 1.- bipolar charging;
 2.- absolute diffusion and, 3.- field chargings;
 4.- diffusion charging, $\alpha = 30$, $E=100$ V/cm;
 5.- field charging, $\alpha = 2.5$, $E=5000$ V/cm.

It can be seen that electric mobility reflects the particle size rather well and therefore is usable in particle size analysis, however, with some limits. As seen from the figure on unipolar charging, the particles of different sizes but of the same electric mobility are possible and some extra information is needed for the correct estimation of the distribution.

3.5 Analysis of electric mobility of particles

To analyse electric mobility an aspiration capacitor is mostly used. The classic aspiration capacitor consists of two electrodes with an electric field between them. The charged aerosol flux passes between the electrodes. Particles are deflected from the flux by the electric field, the speed of the deflection depending on the particle electric mobility.

The theory and practice of the aspiration capacitor are thoroughly discussed in the paper by Tammet (1970). He states that trajectories of charged particles are formed so that there is a strict proportionality between the amounts of air flux F passed by the particle and the passed electric field flux M :

$$F + k(r, q)M = 0 . \quad (3.24)$$

The coefficient of proportionality k denotes the mobility of ions (here the particles). The flux of electric field is better determined through electric capacitance:

$$M = 4\pi\epsilon_0 C U . \quad (3.25)$$

As is seen from Equation 3.24 and 3.25, particle mobility can be analysed on the basis of several capacitor parameters; air flux F , electric capacitance C or voltage U of which the voltage is usually preferred.

We will consider capacitance as an analyser parameter. In a capacitor with cocylindrical electrodes and with the aerosol flux moving parallel to the axis, capacitance fully determines the particle drift in the radial direction of the capacitor [Tammert 1970] and the capacitance value at which the particle reaches an electrode. If the air flux to be crossed by particle F is known, the capacitance $C(l)$ of the section of the capacitor from the inlet to the deposition of the particle on electrode l is determined by the particle mobility as

$$C(l) = \frac{F}{4\pi\epsilon_0 U k(r, q)} . \quad (3.26)$$

Later on capacitance C will be treated as the measure of the length of the analyser.

Of different types of mobility analysers the double differentiating aspiration capacitor is one of the best discriminating power and therefore most suitable for use in aerosol spectrometry as the charged aerosol is only a narrow layer F_a of the total inlet flux, the rest is the air F_g containing no electric charges and the particles with the mobility k reach the opposite electrode within the capacitance C :

$$\frac{F_g}{4\pi\epsilon_0 U k} < C < \frac{F_g + F_a}{4\pi\epsilon_0 U k} \quad (3.27)$$

Consequently, the ability of the capacitor to analyse the mobility of the aerosol can be characterised by the mean value of the capacitance:

$$C = \frac{F_g + \frac{F_a}{2}}{4\pi\epsilon_0 U k} \quad (3.28)$$

and by the half width of the capacitance range σ_C in which the particles of the mobility k reach the electrode:

$$\sigma_c = \frac{C_{\max} - C_{\min}}{2} = \frac{1}{2} \frac{F_a}{4\pi\epsilon_0 U k} . \quad (3.29)$$

Equation 3.28 and 3.29 describe the transformation of electric mobility performed by an analyser. If the capacitance of the particle deposition site is known, the particle size can be estimated by The equations of section 3.3 and 3.4.

4. MODELLING OF ELECTRIC AEROSOL SPECTROMETER

4.1. Apparatus equation of electric aerosol spectrometer

Basing on the discussion of the previous chapters an apparatus equation for the electric aerosol spectrometer can be specified as

$$I(C) = \int_0^{\infty} H(C,r) f(r) dr + \Delta(C). \quad (4.1)$$

Here the electric current density denoted as $I(C)$, serves as the apparatus record with analyser capacitance C as the record argument. Information pertaining to the spectrometer expressed by apparatus function $H(C,r)$ includes the parameters of the charger and the mobility analyser.

The transformation of the information on the aerosol distribution function $f(r)$ into the electric current density $I(C)$ induced by the flux of charged particles can be followed by the chain:

$$f(r) \rightarrow f1(q(r)) \rightarrow f2(k(q,r)) \rightarrow I(C(k(q,r))).$$

The apparatus function $H(C,r)$ described as the response of the instrument to the delta-function type distribution (see Sect. 3.1), can be estimated by the similar chain on the basis of the equations of the section 3 as delta-function describes the distribution of the monodispersed aerosol of radius r .

The apparatus function having been determined, the distribution of an aerosol can be measured by measuring the electric current distribution of the aerosol and solving the apparatus equation (Eq. 4.1) [Tammet 1975a].

Two groups of problems of solving Equation (4.1) can be pointed out. One group is related to the precision level of the apparatus equation. It includes the precision of the apparatus function and the apparatus record. The accuracy of the record can be viewed as a problem of signal processing. The required accuracy of the apparatus function can be achieved finally by calibration.

The other group involves problems of solvability conditions of the apparatus equation. We assume that the mathematical problems of solving the equation actually arise from the instrument design, and can be avoided if the design is made by accounting the characteristics of the measurement technique and measurement object.

Now we can interest ourselves in the potentials of electric aerosol spectrometry.

4.2. Transformation of the information by the spectrometer

By aerosol measurements, the particle distribution is found indirectly. Two stages of the process can be distinguished.

The first stage, already discussed, is the transformation of the directly unrecognisable information pertaining to the aerosol distribution characteristics into its measurable form by a physical device resulting in the abstract data in the apparatus record.

The second stage is processing the measurement data into the distribution evaluate. From informational point of view the direct measurement information (apparatus record) is combined with the information concerning the characteristics of the measuring device (apparatus function) and the object of measurement (the structure of the apparatus equation and ways of solution).

There is no doubt that both stages are equally important in the successful measuring process. Their respective role in the process and possible difficulties of application are in direct dependence of the existing possibilities of and requirements set to the certain field of measurement. So far these two stages tend to be discussed in isolation in relevant literature.

There are a number of methods of processing measurement data [Tikhonov 1985, Paatero 1990, Crump and Seinfeld 1982, Winklmayr *et al.* 1990] mostly aiming at the measurement data transformation. The distribution model is often determined by the researcher's hypothesis. The actual characteristics of the measurement object and the possibilities of the instrument are almost ignored in the discussion and the instrument is taken for granted as a predetermined tool.

Measurement errors may originate from certain instrument characteristics, or conditions under which the measurement is carried out or from certain features of the object of measurement. If this is the case, the appealing results may turn out false.

These errors could be avoided if the instrument has been designed with due consideration of the possibilities of data processing. The actual capacity of the device is also of importance in data processing, especially in aerosol spectrometry working with as aerosols are the objects of statistical measurement.

The point is that a spectrometer must be designed to meet the principal conditions of solving the apparatus equation for the instrument.

Although there are a number of different approaches to spectrometry and terminology varies when spectrometry is described by researchers, any

spectrometric data computing is in essence distribution determination with the help of available information. We use the theory of finite-dimensional linear spectrometry [Tammets 1975], as it can be easily related to an aerosol distribution measuring process. The well-known optimality conditions of linear spectrometry are in accordance with the aerosol measurement conditions. Also well elaborated methods of linear algebra can be used in data processing, enabling the mathematical interpretation of the spectrometer characteristics.

4.3 Measurable distribution functions of aerosols

Aerosol distribution can be presented in a number of forms of different measurability. Most aerosol theories rely on the concentration density size distribution function expressed as the limit of the ratio of the concentration of particles within the certain size range $N(r+\Delta r)-N(r)$ to the range amplitude Δr :

$$n(r) = \lim_{\Delta r \rightarrow 0} \frac{N(r + \Delta r) - N(r)}{\Delta r} = \frac{dN(r)}{dr} . \quad (4.2)$$

Here $N(r)$ is the cumulative distribution defined as the concentration of particles with radii, smaller than r . It relates to the density function by an integral:

$$N(r) = \int_{r=0}^r \frac{dN(r)}{dr} dr . \quad (4.3)$$

The cumulative distribution being physically better treatable comparing to the density function, is more suitable for practical use with physical instrument.

In practice a cumulative distribution based discrete description of aerosol is often used, where the distribution is presented in the form of values N_i of n fraction concentrations, where $i = 1..n$. They are related to the cumulative distribution by the equation:

$$N_i = N(r_{i+1}) - N(r_i) . \quad (4.4)$$

Also the set of fraction boundaries r_i , $i=1..n$, must be given for a full description of the fraction concentration distribution.

The applicability of the different presentations of the distribution [Eq. 3.1 and 4.1] is restricted by the fact that the amount of measurement in-

formation produced by any physical apparatus is limited. This means that the apparatus record cannot be measured in the form of an infinitely detailed, exact continuous function. Consequently, it is not possible to solve the apparatus equation (3.1, 4.1) in the continuous form when the detailed continuous distribution function is to be found, and the task of solving the continuous apparatus equation has been incorrectly set.

The apparatus equation can be solved provided that the required amount of information for distribution determination, does not exceed the amount of information produced by the instrument. Consequently, any distribution estimate can be of limited details and limited accuracy determined by the capacity limits of the instrument. A distribution, presented in the form of a finite number of coefficients of finite exactness, is the only measurable. In aerosol spectrometry, only the distribution expressed in the form of a set of fractional coefficients of limited accuracy is measurable.

The kind of distribution presented in the form of coefficients can be called a spectrum and the respective measuring device can be called a spectrometer.

The spectrum of fraction concentrations defines the total concentrations of the particles in fractions but leaves the shape of the distribution function inside fractions undefined. For a more detailed distribution the fractional widths must be shorted. The precision level of the spectrometer has to be increased correspondingly, which can be a difficult or even impossible task.

And yet, there is a solution based on the knowledge of the regularities of the atmospheric aerosol distribution. A change in the particle size does not lead to a significant change in the particle concentration density, and the distribution can be described without making the spectrum too complex. Proceeding from the possible shapes of the distribution to be approximated, a set of n linearly independent elementary distribution functions $\phi^j(x)$ can be selected so that any possible distribution $\phi(x)$ can be described by the linear combination of these elementary distribution functions [Tammets 1975]:

$$\phi(x) = \sum_{j=1}^n \varphi_j \phi^j(x) . \quad (4.5)$$

A concrete set of coefficients φ_j as a spectrum ϕ , determines the concrete distribution. The n elementary distribution functions $\phi^j(x)$ serve as the basis of the distribution and these functions can be interpreted as the basis functions of an n -dimensional space. Coefficients φ_j determine one

point in the space of possible spectrums and can be treated as a vector of the spectrum. So, distribution measuring boils down to establishing the relevant spectrum. The full shape of the distribution can be calculated with the help Equation 4.5.

The number of basis functions (n) depends on the required precision of the distribution approximation (Eq. 4.5), and can be quite small. In the extreme case it can be one, when the shape of the distribution is predetermined and considered as the basis function.

In aerosol studies the three-modal atmospheric aerosol distribution model proposed by Whitby, is widely accepted [John et al. 1990]. The distribution is formed by superposition of three elementary lognormal distributions with 3*3 parameters. Actually it can be treated as a non-linear variant of the model (Eq. 4.5) with the parameters as the components of the spectrum.

The less a priori information is known about the shape of the distribution, or the more varying it is, the larger basis is required. Compromise depends on the character of the objects under study and our knowledge about it. Even in case of three-modal model the total number of coefficients to be estimated is quite large - nine. The prior definition of the basis function set needs careful mathematical simulation testing because the specialities of distribution shape can be products of the specialities of the basis functions applied.

4.4 Model of a finite-dimensional linear aerosol spectrometer

The apparatus equation (3.1) can be transformed to a system of linear equations (4.6) over Equation (4.5):

$$\psi_i = \sum_{j=1}^n h_{i,j} \cdot \varphi_j + \Delta_i, \quad i = 1..n. \quad (4.6)$$

In matrix form it is

$$\psi = H \cdot \varphi + \Delta. \quad (4.7)$$

Here the spectrum is described on the basis of n elementary distribution functions $\varphi^j(x)$ (Eq. 4.5). m results of measurement ψ_i form the vector of the apparatus record ψ . The measurement errors are described by random vector Δ . On the given basis, the spectrometer is described by apparatus matrix H . The coefficients φ_j , that form the vector of the spectrum φ , have to be found. Measurement errors are characterised by the covariation matrix D of the record. The elements of matrix H are related to the apparatus function $H(y,x)$ by the equation:

$$h_{i,j} = \int_{\mathbb{R}^n} \mathcal{H}_{i,j}(x) \varphi^j(x) dx . \quad (4.8)$$

The solving of Equation (3.1) is now reduced to the solving of a system of linear equations (4.7). The ways of solving a system of linear equations are well researched and the required conditions are known. The problem of incorrectness of Equation (3.1) has been replaced by the problem of conditionality of the matrix (4.8). It means that now the success of solving the system depends on the properties of matrix H and errors of record elements ψ_i expressed in covariation matrix D .

Physical analogy to the equation solvability is the ability of a spectrometer to discriminate (resolve) spectra. The fully diagonal matrix with all its nondiagonal elements being equal to zero, is the best determined and the best discriminating one, as the value of a certain element of the spectrum is wholly determined by one and only one element of the record without any dependence on other record elements. This kind of spectrometer is of absolute resolution ability in regard to basis spectra as they are not interfering in the record. The less expressed the diagonality of the apparatus matrix, the less conditioned it may be. As there will be more interference between the basis spectra in the record, the less they can be discriminated and the worse will be the resolution of the spectrometer. The problem is basically the same also with matrixes of more complicated structure

Another factor influencing the measurements is the ever-present measurement errors described by the covariation matrix D . As errors of magnitude in comparison with the signal magnitude, may produce wrong spectra even by a good apparatus matrix, the spectra can be discriminated on the concentration scale in case the difference in spectra values exceeds the values of measurement errors. Thus the concentration discrimination is in direct relation to the signal-to-error ratio called sensitivity. The measurement error magnitude depends well on the characteristics of the signal recording device, and is practically independent of the other characteristics of the spectrometer. The signal magnitude depends on the aerosol-into-signal transformation mechanism, on the amount of the aerosol measured and the time of measuring.

The vital conclusions from the discussion above for apparatus design, point to the two qualities - discriminating ability and sensitivity - of the spectrometer, that must be met. Both criteria are to be defined in dependence of the measurement objective.

Taking into account the state of present atmospheric aerosol research the spectrometer will enjoy a wide range of application to measure aerosols of different situations. The basis for selecting the number and shape of

the basic distributions for the aerosol spectra is the need to study a wide range of particle sizes with about equal interest to any part of the range. As about distribution details, only a few sources of aerosol display the relative width of the distribution less than 10%. The width more than 20% is a typical one, rising with time due to the processes in the aerosol. It can be concluded that the logarithms of particle sizes could be spectrum argument and the resolution of the instrument about four fractions per the interval of tenfold change in particle size is satisfying enough for describing the aerosol peaks of 20-30% of relative half-width being enough detailed for atmospheric aerosol studies.

Accordingly, one basis function should describe the aerosol distribution of the width of one fraction and, outside the fraction, the function has to be of about the zero value for the sake of simplicity. On the other hand, as the atmospheric aerosol distribution can be rather smooth and without peaks, the smooth distributions should also be approximable by the set of basis functions. Well suited for this purpose is a set of triangular functions [Tammet 1980].

5. SPECTROMETER QUALITIES

Before designing a modern spectrometer possible designs are to be examined to see how well they meet the requirements set to instruments measuring atmospheric aerosols.

Good measuring quality is a complex phenomenon consisting of a number of mutually exclusive characteristics. The quality can be estimated by evaluating the characteristics according to their significance. As the apparatus equation solution accuracy (3.1, 4.1) can be considered the main characteristic of a spectrometer it should be evaluated first.

The evaluation is not a problem if the parameters of the apparatus equation are known. They are not when the spectrometer is being designed and the evaluation is to be made by relying on indirect criteria.

The spectrometer design assessment is simplified by evaluating the concentration resolution and the size resolution separately. The size resolution is assessed without error consideration. The measurement errors are considered as affecting the concentration resolution and are to be evaluated through the sensitivity of the spectrometer. To assess both resolutions the relevant characteristics of the spectrometer charger and the analyser as well as the methods of recording the signal should be analysed.

The analysis of the physical characteristics of spectrometer is preferred to the mathematical analysis of the apparatus equation (4.1) or the matrix equation (4.7) as the mathematical analysis requires the preliminary determination of the spectrometer and the spectrum models. Particularly, we will avoid the preliminary selection of spectrum model being a special problem of spectrometry [Tamm 1988a, 1988b] and can affect the evaluation of the instrument.

5.1 Quality of charging

Suitability of electric charging for classification of aerosol particles by size has been discussed in the paper by Tamm (1975). He introduced the term of quality in order to evaluate the charging process:

$$x = \frac{r}{\sigma_{k/r}} \int \frac{k}{dr} \quad (5.1)$$

Here k and $\sigma_{k/r}$ are the mean value and the half width of the distribution function of electric mobility for monodispersed charged aerosol particles of the radius r , respectively.

The quality of charging process can be estimated by knowing the parameters of the particle charge distribution (Eq. 3.6, 3.7, 3.18, 3.13 and 3.22).

By applying the quality assessment to the charger as a device, the nonuniformity of charging conditions in different parts of the charger must be considered and the parameters in Equation (5.1) must be estimated for all the aerosol at the charger outlet.

It has been shown [Tammiet 1980] that the total differences of particle charges in a charger can be much larger than those accountable for by the stochastic nature of charging. The difference is caused by inevitable nonhomogeneity of charging conditions in the charger (the charger nonhomogeneity).

Two factors of nonhomogeneity can be distinguished. One is the charging parameter variation brought about by the scattering of ions due to electrostatic repulsion:

$$\frac{a_{\max} - a_{\min}}{\bar{a}} = \frac{h}{t_q} \frac{\bar{a}}{k_i E}. \quad (5.2)$$

Here h and t_q are the width of the charging zone and the charging time, respectively.

The mean charge of particles passing different sections of the charger as well as the electric mobility will be different (Eq. 3.20).

Another factor to be considered, is the nonhomogeneity of the electric field density the value of which depends on the charger design.

Both, the ions and the field densities affect the width of the particle charge distribution. In the first approximation the total width of the distribution can be estimated as the sum of three components:

$$\sigma_{U,q/r} = \left| \sigma_{q/r} \right| + \left| (\sigma_{\alpha/r} \pm \sigma_{E/r}) \right|. \quad (5.3)$$

Here $\sigma_{U,q/r}$ is the total standard deviation of the charge distribution of the particles of radius r , $\sigma_{q/r}$ is that of the stochastic nature of charging, σ_{α} is the deviation caused by the nonuniformity of the charging parameter and σ_E is the deviation due to the nonhomogeneity of the electric field in the charger. The last two components are well-correlated nonstochastic parameters and the argument of the sum of dispersions is replaced by sum of the deviations as the correlation between the nonuniformities is usually positive.

To evaluate the charger quality (Eq. 5.1) the deviation of charge $\sigma_{q/r}$ can be transformed into the deviation of the electric mobility distribution in the following way:

$$\sigma_{k/r} = \sigma_{q/r} \left| \frac{dk}{dq} \right|. \quad (5.4)$$

The quality of mobility analyser as well as the whole spectrometer can be assessed. To evaluate the analyser quality the arguments of Equation (5.4) should be the particle mobility and the analyser capacitance. To evaluate the spectrometer quality the arguments should be the particle radius and the analyser capacitance.

5.2 Resolution ability

The quality assessment makes it possible to compare chargers. A low quality index can indicate that it is not possible to differentiate particles of different sizes by their electric mobility, it also points to the low resolution ability of the spectrometer. However the quality is not an adequate index for denoting the suitability of a charger for spectrometer as a too high quality index may bring down other characteristic values such as the sensitivity of the spectrometer.

The relative resolution index can serve as criterion of sufficiency [Tammet 1973]. The spectrum formed by the superposition of two single-mode spectra with the equal distribution width is considered. The relative resolution can be defined as the ratio of the mode difference to the width of the spectra. Applied to a charger it can be expressed mathematically as

$$\delta_{k/(r_1, r_2)} = \frac{|k(r_1) - k(r_2)|}{\sigma_{k/r}}. \quad (5.5)$$

The spectra are resolvable in the classic sense of the term if the resultant spectrum becomes two-modal. Spectra of normal distribution are resolvable when the relative resolution δ is larger than 0.85:

$$\delta > 0.85. \quad (5.6)$$

Modern resolution analysis is based on mathematical statistics and the criterion of sufficiency may differ from the classic one [Tammet 1973]. All kinds of errors, technical errors, those caused by structural composition variations of the aerosol, should be taken into account in comprehensive analysis. As this information is not yet available we shall resort to the classic criterion.

In fact the quality index can be viewed as the density function of the relative resolution on the relative (logarithmic) scale:

$$\delta = \frac{r_{i+1} - r_i}{\sigma_{k/r}} \left| \frac{dk}{dr} \right| d(\ln r) = \frac{k(r_{i+1}) - k(r_i)}{k(r_i)} \frac{|dk|}{\sigma_{k/r}} = \frac{|k(r_{i+1}) - k(r_i)|}{\sigma_{k/r}} \quad (5.7)$$

Here r_i and r_{i+1} are the radii of the neighbouring spectrum fractions.

5.3 Resolution of charging

The splitting of the spectrum into fractions is justified if the fractions are resolvable. We will base our analysis on the resolvability of aerosol fractions. The relative resolution for a charger is expressed by the equation:

$$\delta_{B,j} = \frac{|k_B(r_{i+1}) - k_B(r_i)|}{\delta_{B,k/r}}, \quad \delta_{U,j} = \frac{|k_U(r_{i+1}) - k_U(r_i)|}{\delta_{U,k/r}} \quad (5.8)$$

Here B and U denote respectively bipolar and unipolar chargers.

The relative resolutions of different types of charging versus particle size are given in Figure 3. The spectrum fractions are resolvable if the value of the resolution (Eq. 5.8) exceeds the threshold value of 0.85.

Bipolar charging provides enough resolution for the particles up to the particle radii 250 nm. Absolute diffusion charging (Fig. 2) is applicable to particles with radii below 1600 nm. Absolute field charging can be used on the range of up to 38 nm of radii and again from the radii 140 nm onwards on the larger particle range. However, these ranges of particle sizes vary for different chargers, the largest changes being effected for diffusion chargers.

Resolution in electric aerosol spectrometry can be treated as consisting of two components. The one, discussed above, is the resolution of the neighbouring fractions, which depends on the relative widths of the charge (mobility) distributions.

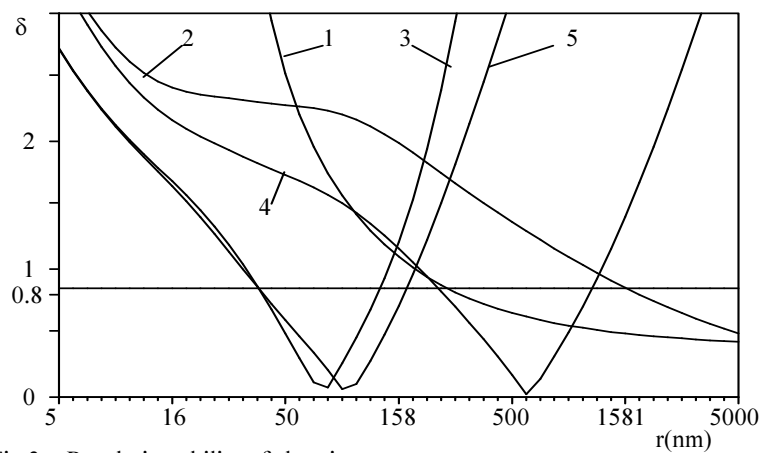

Fig.3. Resolution ability of chargings.

- 1.- bipolar charging;
- 2.- absolute diffusion and, 3.- field chargings;
- 4.- diffusion and, 5.- field chargings;

The other component is the resolution embracing the full size range of the spectrum requiring the calculation of the resolution of a certain fraction and all other fractions. As Figure 1 demonstrates there are always particles of different sizes but the same mobility and, therefore, nonresolvable (see Eq. 5.5), no matter, what the width of the charge distribution is. In that case the charger is not suitable for full range measurements. It is applicable for measurements within a certain size range segment, provided that the particles of other range segments do not affect the measurement result (e.g., they have been removed by a prefilter). The same relates also to the practical diffusion charging.

The implications of resolution analysis for measurement practice are twofold: 1) it defines and limits the measuring range of the electric methods and, 2) it sets a requirement for particle size range limitation before the measurement. The problem will be dealt with and a solution offered later in this paper.

5.4 Resolution of mobility analyser

Relative resolution to assess the quality of a mobility analyser can be expressed as follows:

$$\delta_{A,C/ki} = \frac{|C(k_{i+1}) - C(k_i)|}{\sigma_{C/k}} \quad (5.9)$$

The formula (5.9) can be modified and the properties of the mobility analyser included:

$$C_{k(i+1)} - C_{k(i)} = \frac{\bar{F}}{4\pi U} \cdot \frac{k(i+1) - k(i)}{\bar{k}}, \quad (5.10)$$

where

$$\bar{F} = F_g + \frac{F_a}{2}. \quad (5.11)$$

The estimation of the width of the analyser output distribution (Eq. 3.29) gives the expression of the analyser resolution on the scale of electric mobility:

$$\delta_{A,ki} = 2 \frac{\bar{F}}{F_a} \frac{(k_{i+1} - k_i)}{\bar{k}}. \quad (5.12)$$

5.5 Resolution of spectrometers

Relative resolution of a spectrometer can be defined as follows:

$$\delta_{S,C/r} = \frac{|C(r_{i+1}) - C(r_i)|}{\sigma_{S,C/r}}, \quad (5.13)$$

where $\sigma_{S,C/r}$ is the standard deviation of the distribution function of the monodispersed aerosol with particle radius r , at the outlet of the spectrometer, on the scale of the analyser capacitance.

It must be taken into account that the widening of the capacitance distribution curve is gradual. First widening on the scale of capacitance happens when particles are charged. The other widening is caused by the analyser himself. The total half-width can be estimated as

$$\sigma_{S,C/r} = \sigma_{A,C/\bar{k}} + \left| \frac{dC}{dk} \right| \sigma_{k/r}, \quad (5.14)$$

where $\left| \frac{dC}{dk} \right|$ is the transmission coefficient and $\bar{k} = \overline{k(r)}$ is the mean mobility of particles with radius r .

5.5.1 Aerosol focusing in spectrometers

The dispersion of the aerosol in the analyser as well as the dispersion effected by the charger are neither fully independent nor fully stochastic,

so the correlation of the nonhomogeneities should be taken into account when developing Equation (5.14).

Particles of higher charge are of higher mobility and so the total dispersion at the output of the analyser can be reduced when the distance to the deposition electrode for particles of larger charges is longer than for particles of smaller charges at their entrance into the analyser. The effect can be viewed as aerosol focusing and was described first by Yosikawa *et al.* in 1956.

The effect of aerosol focusing can be described by the negative correlation of the processes in the charger and in the analyser. Mathematically it can be expressed by the equation:

$$\sigma_{S,C/\bar{r}} = \left| \sigma_{A,C/k} - \frac{C}{dk} \sigma_{\alpha,k/r} + \sigma_{E,k/r} + \frac{C}{dk} \sigma_{q,k/r} \right| \quad (5.15)$$

The minus sign expresses the negative correlation of the dispersions in the equation.

As shown in Figure 4, the value of total resolution of the spectrometer is higher than the values of the components (Fig. 4).

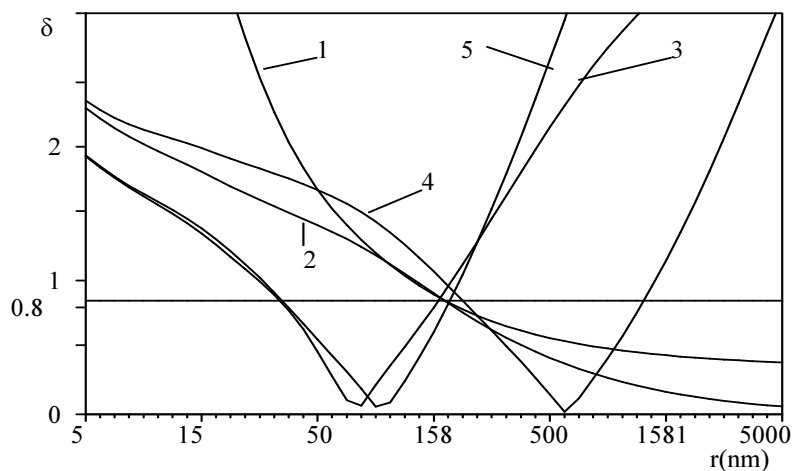

Fig.4. Resolutions of the spectrometers with different chargers
 1. Bipolar charger; 2. Absolute diffusion charger;
 3. Absolute field charger; 4. Diffusion charger; 5. Field charger.

The resolution of the spectrometer with the absolute charger is lower than that with the real charger as the absolute chargings are ideal homogeneous processes and the dispersion in the analyser is not compensated.

It is worth mentioning that the radius of about 180 nm seems to be a kind of boundary size for all chargings.

5.6 Spectrometer sensitivity

Concentration differentiation is another important characteristic of a spectrometer. The concentration resolution can be expressed through spectrometer sensitivity as the sensitivity determines the minimal concentration level that can be differentiated. The limit is set by the value of the concentration measuring errors.

We assume that errors caused by the peculiarities of the aerosols and errors made in determining the parameters of the spectrometer, will be taken into account at calibration. We also assume that the technical parameters can be made stable. Provided these conditions can be fulfilled, only the errors of signal recording need to be discussed. As the errors determine the minimal difference for the concentrations to be considered different, they are of importance only in comparison with the concentration values and determine the value of the minimal measurable aerosol concentration as well.

Single-parameter instrument sensitivity can be defined as the required minimal value of the parameter at the predetermined signal-to-noise ratio.

Spectrometer sensitivity can also be defined as the minimal aerosol concentrations in fractions providing the predetermined signal-to-noise ratio. The definition is simple but it is of little use in deciding about the suitability of a spectrometer for measuring atmospheric aerosol, as the size range of the aerosol spectrum is of about four decades and the measurement errors can vary significantly in different segments of the spectrum. Aerosol concentrations can be presented in different ways, as the number concentration (as it has been done in this paper) or as surface or volume (mass) concentrations all of which are in different dependence upon the particle size. Errors can be powered up differently. By the volume concentration it reaches r^3 times. The particle concentrations in fractions can also differ very much. The typical range of concentration values for atmospheric aerosols is extends four to six decades.

The atmospheric aerosol spectrum is characterized by a number of regularities expressed in the form of typical atmospheric aerosol distributions. The Junge distribution is well known. A three-modal atmospheric aerosol distribution was proposed by Whitby. The gamma distribution, its various modifications, etc., are also in use [Smirnov 1984, Smerkalov 1984]. A rationalised KL-distribution was proposed by Tammet (1992).

When the aerosol distribution factor is considered spectrometer sensitivity can be defined as the minimum value of the composite concentration of the atmospheric aerosol particles at the predefined signal-to-noise ratio. The composite concentration can be defined as a weighted sum of aerosol fraction concentrations. As the fraction weights and the required signal-to-noise ratio are in relation with the aim of the study, we will not predetermine them but separately estimate the ratio in each fraction of the atmospheric aerosol of the typical distribution. The composite sensitivity can be estimated after the fraction weights have been determined.

A KL-distribution [Tammet 1992] is used as a model of the mean atmospheric aerosol distribution:

$$N_i = \frac{A}{r_0 + r_i} \quad (5.16)$$

The parameters are taken as follows:

$$r_0 = 75 \text{ nm}, K = 3, L = .4 \text{ and } A = 3000 \text{ particles per cm}^3 \quad (5.17)$$

5.6.1 Estimation of the signal-to-noise ratio

The signal-to-noise ratio can be determined by measuring an aerosol of determined distribution. The task can be simplified by assuming the additivity of noise; the measurement errors do not depend on the aerosol concentration value, and the error values can be estimated through covariation matrix D of the apparatus equation (4.7).

As the covariation matrix is not known yet, we will estimate the signal-to noise ratio by comparing the estimates for the output signal and the measurement noise values. We will ignore the overlapping of aerosol fractions at the spectrometer output and possible signal losses by the registration, to simplify the calculations.

5.6.2. Spectrometer noise

We will only consider the noise of the detecting system. We will neglect the stochastic noises of the charger and the analyser, assuming that they are small as being averaged over a great number of particles and ions.

In case a particle counter is used as the detector device, the count of particles is the signal and the statistical error of counting is the noise. By electric detection, the electric current induced by the charged particles is the signal and the error of electric current measurement is the noise.

5.6.3. Output signal of the spectrometer

The number of particles reaching the detector in one second can be estimated by the formula:

$$N_{S,i} = (1 - Los) p_+ n(r_i) F_a , \quad (5.18)$$

where p_+ is the probability of a particle of radius r_i to have a charge of a certain (positive) polarity. The probability can be less than one as there can be also uncharged or charged particles of the opposite sign. $n(r_i)$ denotes the concentration of the particles of radius r_i .

The particle induced current by electric detection can be calculated by:

$$I_S(r_i) = e \overline{q_{r_i}} (1 - Los) F_a n(r_i) , \quad (5.19)$$

where $\overline{q_{r_i}}$ denotes the mean charge of a particle providing only the charges of a certain polarity are considered. The charged particles of the opposite sign are considered uncharged because they as well as the uncharged particles have no effect on the spectrometer output.

The argument Los takes into account the losses in the charger. According to $\overline{q_{r_i}}$ definition there is no particle loss in the analyser as the particles which do not effect the signal are included in the $\overline{q_{r_i}}$ value. The inlet losses are ignored as they depend on the inlet design and are to be estimated later.

5.6.4. Particle losses in the charger

The losses in the charger can be estimated basing on the charger model proposed by Tammet (1980). The charged particles are also ions but whose charge changes over the charging time.

We can define the charger critical time t_0 as follows:

$$t_0 = \frac{h}{E k_p} . \quad (5.20)$$

The relative drift of particles in the charger can be written as t_q/t_0 , where t_q is the charged particle residence time in the charger. The drift determines the width of the aerosol layer near the wall of the charger, where the particles are removed from. The particles are deposited on the wall and do not pass through the charger. The relative loss of particles in the charger can be expressed as follows:

$$Los = \begin{cases} 1 & \text{if } t_0 > t_q \\ 0 & \text{if } t_0 \leq t_q \end{cases} \quad (5.21)$$

All the particles whose residence time in the charger after charging t_q is higher than t_0 are deposited and their $Los=1$.

Combining (Eq. 5.20) and the equation $\bar{E} = \frac{h}{\Theta t_q} \frac{\bar{\alpha}}{k_I}$ [Tammets 1980]

we can have the expression:

$$\frac{t_0}{t_q} = \frac{\Theta}{\alpha} \frac{k_I}{k_p} \quad , \quad (5.22)$$

which shows that the particle losses in the charger depend on the same general characteristics of charger as do the nonhomogeneity of electric field density Θ and the charging parameter α . A charger with a smaller nonhomogeneity value is sure to have higher particle loss value.

5.6.5. Reduction of losses in the charger

The losses are large for particles with high electric mobility such as small particles and field charged large particles. As both cases are characterised by high relative resolution (Fig. 3), it is possible to reduce the losses by increasing the nonhomogeneity but reducing the resolution, of the charger. On the other hand that can decrease the resolution index for middle size particles below the critical level.

The difficulty can be overcome by introducing an extra charging zone between the ion source and the basic charging zone. As a result the charging conditions for particles with low electric mobility are not changed, but the deposition of high mobility particles from the basic zone is compensated by the access of particles from the extra zone. The critical time of the modified charger can be approximately L_U times of the critical time of unmodified charger:

$$t_0 = L_U \frac{h}{E k_p} \quad . \quad (5.23)$$

L_U is the ratio of the inlet and the outlet widths of a charger, the width of extra zone being L_U-1 times of the width of the basic zone. The ratio of the aerosol fluxes corresponds to the width ratio.

The losses in the modified charger can be expressed as follows:

$$\begin{aligned}
 Los = & \begin{cases} 1 & \text{if } t_0 > t_q / (L_U - 1) \\ t_q / (L_U - 1) & \text{if } t_q / (L_U - 1) \geq t_0 > t_q / L_U \\ t_q / L_U & \text{if } t_0 \leq t_q / L_U \end{cases} \quad (5.24)
 \end{aligned}$$

The reduction of particle loss makes it possible to widen the spectrometer measurement range with no lowering of the minimum resolution and sensitivity values. Increased aerosol consumption is no problem in atmospheric aerosol measurement.

The particle electric mobility variation during the charging, can be corrected by modification of the particle residence time t_q .

5.6.6 Sensitivity of aerosol spectrometers

Aerosol spectrometer sensitivity is calculated as the ratio of the induced electric current (Eq. 5.19) to the noise current σ_I :

$$\zeta_S = \frac{I_S(r)}{\sigma_I},$$

where $\sigma_I = 10^{-15}$ A, aerosol flux = 200 cm³/s and $L_U = 2$. The other charger parameters were as shown in Figure 2. The comparison of the sensitivities of different chargers shows that the bipolar charger size range is limited (Fig. 5).

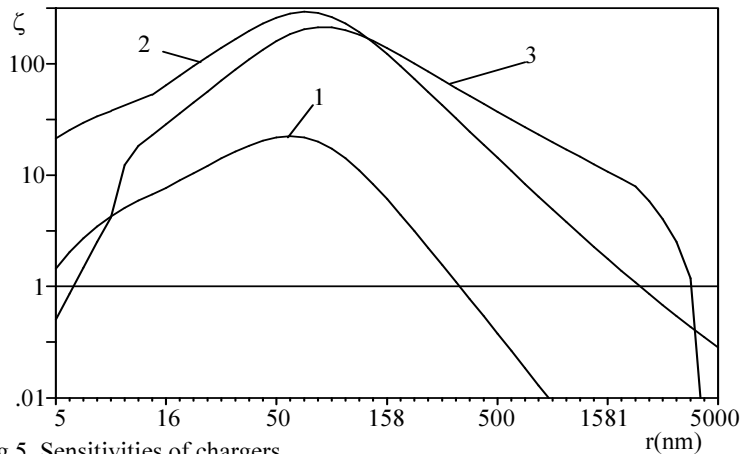

Fig.5. Sensitivities of chargers.

1. Bipolar charger; 2. Diffusion charger; 3. Field charger.

In small particle range the diffusion charger has the highest sensitivity. Field charging, providing the best sensitivity in the range of large par-

ticles is limited by a fast drop of sensitivity at the size 5000 nm of particle radius effected by the losses in the charger because of the strong electric field and only well-designed geometry of the field charger can help.

Spectrometer sensitivity can be improved by reducing the noise of the electric current measurement. The noise current of electrometers has been studied by Saks and his colleagues [Rebane 1987]. In aerosol measurements the noise is limited to the value of about 10^{-16} A by the electric noise of air volume at the electrometer input.

6. PRINCIPLES OF A WIDE RANGE SPECTROMETER

6.1. General principles for a wide range spectrometer

Charging sets the main limits for the aerosol spectrometer measurement range (Fig. 3 and 4). In the small particle range all types of charging have sufficient resolution power, the diffusion charging seems the best because of the high sensitivity. In the large particle range, the field charging has the highest resolution as well as sensitivity characteristics to measure atmospheric aerosols but it also brings the distortions effected by small particles. In fact, the diffusion charging widely used in measuring instruments has the similar effect by the large particles. For the diffusion charging to measure well in the small size range the effect of large particles must be negligible or considerable systematic measurement errors can happen [Noppel 1990]. The prefiltering of the aerosol can overcome the problem.

The principle of a wide range spectrometer is based on the idea of replacing instrumental prefiltering by computational correction as the effect of the out-of-range particles on the measurement can be computationally corrected provided the effect is known. The effect can be calculated from given particle distribution of that range. For example, it can have been measured by another instrument of other charging type, and visa versa, the concentration distribution in the primary range can be used for correcting the concentration in the other range.

The mutual correction of the concentrations can be performed step by step as an iteration process, but it can be replaced by the solving both tasks together as single system. Mathematically it means joining two apparatus equations (7.1) into one. The complex apparatus equation accounts for the cross-effects and can provide correct aerosol distribution estimate in the full, wide range of aerosol particle sizes [Tammet 1980].

Actually, the technical problems of prefiltering are replaced by mathematical problems of solving the apparatus equation (4.1, 4.7) of complicated structure but free of technical limitations.

6.2. Evaluation of the wide range aerosol spectrometer

The spectrometer estimation methods described above can not be applied to a wide range spectrometer of two different chargers and analysers in combined use.

The methods can be in terms of the distance between vectors in linear space defined according to the formula:

$$\|\varphi_2 - \varphi_1\| = \sqrt{(\varphi_2 - \varphi_1)^T \cdot (\varphi_2 - \varphi_1)} . \quad (6.1)$$

The relative resolution can be treated as a weighted distance between two spectra in one dimensional space, the spectra with sufficient distance between them being resolved. In the case of a wide range spectrometer the space has two dimensions and the resolution ability can be estimated by the sum:

$$\delta_W = \sqrt{\frac{(C_E(r_{i+1}) - C_E(r_i))^2}{\sigma_E^2} + \frac{(C_D(r_{i+1}) - C_D(r_i))^2}{\sigma_D^2}} . \quad (6.2)$$

The formula gives exactly the classic result if one of the chargers has zero resolution. The formula demonstrates the increase of resolution effected by the increase of available information due to two chargers (Fig. 6).

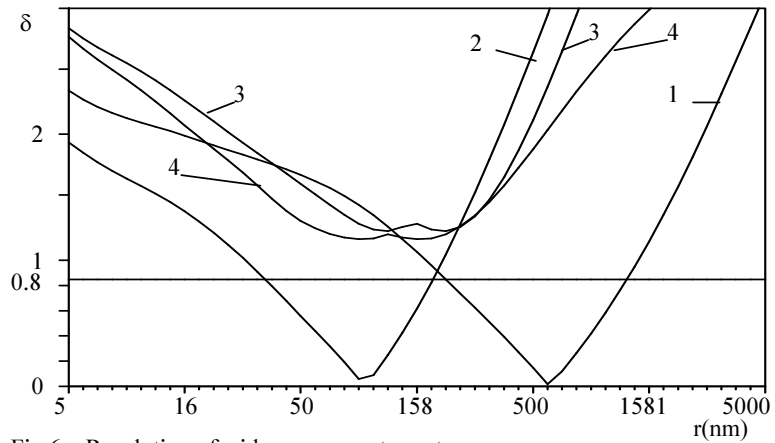

Fig.6. Resolution of wide range spectrometer

1. Only with diffusion charger;
2. Only with field charger;
3. With both, diffusion and field chargers;
4. With both absolute chargers

As sensitivity can also be treated as a measure of weighted distance, a similar method can be applied to estimate the composite signal-to-noise ratio:

$$\zeta_W = \sqrt{\zeta_E^2 + \zeta_D^2} . \quad (6.3)$$

7. CONSTRUCTION PARAMETERS OF SPECTROMETER

7.1. General questions of spectrometer construction

It is very essential to get a system of two chargers working in a strict balance in one instrument as only then the mathematical correction can be valid. Some general principles can be put forward.

The first point is that the chargers should be as different as possible, but with well-determined characteristics in sense of resolution as in that case the signals effected by the particles of different sizes have different characteristics and the correction factor is reduced. One charger is advisable to be a field charger, the second can be a diffusion charger.

The second is that in order to work out the spectrometer technical construction, the spectrometer evaluation method based on an idealised model should be applied also to a real spectrometer. It can be made if the model is in a good correspondence with a real construction. Thus, the construction must be well described by the model.

The parameters needed for successful spectrometer evaluation are mean values of the estimates of the charging parameter, the electric field densities and their nonhomogeneities for the chargers, and the values of mean capacitance and half widths of the distribution of the deposited particles for the analysers.

The cylindrical symmetric construction of the spectrometer can be considered the easiest to model as only the conditions in the axial and radial directions are to be considered. Also the construction is of little boundary effect as the nonuniformity of conditions in the radial direction of the analyser is of no significance. The nonuniformity in the charger may have some adverse effect but it can turn into the aerosol focusing effect (Eq. 5.15) provided the charger and the analyser form a cylindrical system.

7.2. Diffusion charger

The design of a diffusion charger should consider the complex effect of ions and electric field as well as possible effect of the aerosol flow.

7.2.1 Principle of diffusion charger construction

There are two, contradicting each other, characteristics, a diffusion charger should provide; the charging of small particles and the resolution of middle size particles.

Small particles can be effectively charged by the charger of a high charging parameter and of a minimal electric field to avoid particle loss. The minimal electric field provides sufficient resolution for the particles up to 200 nm of radius. To reduce small particle loss (Eq. 5.24) an extra charging zone with extra aerosol, maintaining sufficient resolution capacity in larger particle size range, is needed.

The requirement of cylindrical symmetry limits the possible types of corona discharge to the point-to-cylinder and wire-to-cylinder types. A metallic mesh sometimes used to uniform and stabilise the charging conditions, can be considered ineffective as its effect is similar to a corona wire effect but of reduced ion density and increased electric field as great part of the mesh (nearly half) is closed for ions. The mesh can easily become polluted with aerosol particles.

The diffusion charger can have the shape of a short cylinder with a corona needle in the center. The aerosol is directed parallel to the axes and charged by the ions from the needle. The cylindrical space near the cylinder wall is the basic charging zone and the aerosol from that zone is introduced to the analyser, the central space forms the extra charging zone and the aerosol of that zone should be removed. The construction provides;

- minimal electric field,
- low nonhomogeneity,
- minimum pollution,
- removal of the chemical products of the corona discharge,
- reduction of the small particle loss.

7.2.2 Parameters of the diffusion charger

The mean values and deviations of the charger parameters can be estimated relying on the known dependence of the charging parameter, i.e., ion density and electric field intensity, on the radius. It makes no difference whether the needle or wire is the corona source, the charging zone will be as short cylinder. Due to significant boundary effects the correct analytical description is not available. Considering the shape of the zone we can assume that the charging conditions should be somewhere between the conditions of spherical and cylindrical zones. The idealised cases of corona discharge have been discussed by Tammet (1969).

We will not consider the detailed characteristics of corona discharge but will focus on the charging nonhomogeneity estimation. The mean values of model parameters can be corrected by the calibration.

We will idealise the model described in the paper by Tammet (1979) and assume that the diameter of ion source is infinitely small and the electric field is effected only by the charge of ions. The special effects in the space near the corona source are omitted as the aerosol is removed from that space (see Sect. 5.6.5).

7.2.2.1 Ideal wire-to-cylinder corona

Let us consider the ion and electric field distributions in the ion field generated by the wire in the axis of the infinite cylinder. Let the ion current per unit of the wire length be j_l . As ions are moving strictly in direction of the radius the total ion current through any co-cylindrical surface of the unit length is constant. Consequently the total charge of ions in the cylinder with radius R and the unit length, is equal to $j_l t$, where t is the time an ion needs to move from the axis to R. Let us call it ion age. According to the Gaussian law, electric field density can be described as

$$E = \frac{j_l t}{2\pi \varepsilon_0 R} . \quad (7.1)$$

The ion speed at radius R is equal to

$$\frac{dR}{dt} = k_l E = \frac{k_l j_l t}{2\pi \varepsilon_0 R} . \quad (7.2)$$

Here k_l is ion mobility. The age of ions can be found by integrating, as

$$t = \sqrt{\frac{2\pi \varepsilon_0}{k_l j_l}} R . \quad (7.3)$$

The ion density can be found by the law of electrostatic dispersion as

$$n_l = \frac{\varepsilon_0}{e k_l t} = \frac{1}{e R} \sqrt{\frac{\varepsilon_0 j_l}{2\pi k_l}} . \quad (7.4)$$

Finally, the electric field can be estimated as

$$E = \sqrt{\frac{j_l}{2\pi \varepsilon_0 k_l}} . \quad (7.5)$$

7.2.2.2 Ideal point corona

In this case the ion source is a point with the total ion current (I) in the centre of a sphere. The total amount of ions in the sphere of radius R is equal to $I \cdot t$ and we can find the electric field as

$$E = \frac{I \cdot t}{4 \pi \varepsilon_0 R^2} . \quad (7.6)$$

The ion speed is

$$\frac{dR}{dt} = \frac{k_I I \cdot t}{4 \pi \varepsilon_0 R^2} . \quad (7.7)$$

The ion age can be calculated and finally, the ions concentration can be estimated as

$$n_I = \frac{1}{e R} \frac{\sqrt{\varepsilon_0 I}}{\sqrt{\frac{2}{3} k_I 4 \pi R}} \quad (7.8)$$

and the electric field densities as

$$E = \frac{\sqrt{\frac{2}{3} I}}{\sqrt{4 \pi \varepsilon_0 k_I R}} . \quad (7.9)$$

To compare the point and cylinder coronas, let us fix the radius (R_0) and transform the current (I) of point corona into the current per unit of length at radius R_0 .

The total current through the cylinder of radius (R_0) per unit of length is

$$j_s = \frac{I \cdot 2 \pi R_0}{4 \pi R_0^2} = \frac{I}{2 R_0} . \quad (7.10)$$

We can transform the formulas for E and n (Eq. 7.8, 7.9) by

$$I = j_{S,0} 2 R_0 . \quad (7.11)$$

The ion concentration will be as

$$n_I = \frac{1}{e R} \frac{\sqrt{\varepsilon_0 j_p R_0}}{\sqrt{\frac{1}{3} k_I 4 \pi R}} \quad (7.12)$$

and the electric field as

$$E = \frac{\sqrt{\frac{1}{3} j_p R_0}}{\sqrt{4 \pi \varepsilon_0 k_I R}} \quad (7.13)$$

7.2.2.3 Comparison of cylindrical and point coronas

Comparing the formulas (7.4, 7.5) and (7.12, 7.13) we can see that the difference between the coronas lies in the dependence on the radius by the factor of $\sqrt{\frac{R}{R_0}}$, the numerical values differing 1.2 times provided equal current densities. Thus, we can estimate the mean parameters of the short cylindrical diffusion charger with an error not exceeding $\sqrt[8]{\frac{R}{R_0}}$, as the average of the values for cylindrical and point coronas;

the age of ions depending on radius of the charger as

$$t = \sqrt{\frac{2 \pi \varepsilon_0}{k_I j_0}} R \sqrt[4]{\frac{R}{R_0}}, \quad (7.14)$$

the electric field as

$$E = \sqrt{\frac{j_0}{k_I 2 \pi \varepsilon_0}} \sqrt[4]{\frac{R_0}{R}} \quad (7.15)$$

and the ion concentration as

$$n_I = \frac{1}{e R} \sqrt{\frac{\varepsilon_0 j_I}{2 \pi k_I}} \sqrt[4]{\frac{R_0}{R}} \quad (7.16)$$

As the difference between the characteristics of the short wire and point coronas seems to be small, the needle can be used as the most simple and reliable ion source.

7.3 Field chargers

As the charging parameter of field charging is small, the effect of the electrostatic repulsion of ions can be omitted in the description of the field charger and only the initial ion density and the configuration of the electric field is to be considered.

Strong electric field can be generated with two cylindrical electrodes and a high voltage supply. The ions are introduced through a narrow slit of the inner electrode. The type of the ion source is not important, it can be the needle in the centre of the electrodes. The density of the electric field can be estimated by the formula:

$$E = \frac{U}{R \ln \frac{R_0}{R_1}}, \quad (7.17)$$

R_0 and R_1 being the radii of the outer and inner electrodes, respectively.

As the electrostatic dispersion of ions can be neglected, the charging parameter and the electric field nonhomogeneity depend on the geometrical configuration of the charger.

7.3.1 Particle losses in chargers

Losses in the charger can be estimated through the critical time of the charger (Eq. 5.23). In a diffusion charger the losses can be smaller than those calculated on the basis of the particle charge at the outlet of the charger, as particles are charged gradually and the average shift of the particles will be smaller.

In a field charger, the charging time should be corrected to the charged particle total residence time in the electric field. This time may be much longer than the charging time because of a significant electric field dispersion in the charger. To reduce the losses, electrodes of the minimal possible length as well as extra aerosol flux should be used (Eq. 5.24). The periodic electric field [Hewitt 1957] could do well but it is technically complicated and can upset the electric detection system.

7.4. Construction principles for analysers

The typical construction of an analyser is well established. It consists of two co-cylindrical electrodes. Various constructions of the analyser are discussed by Tammet (1970).

The special effect of aerosol focusing can be put to work if aerosol flows concentrically without turbulent mixing from the charger into the

analyser. As the charging parameter of the inner section of the charger is higher and the particles obtain higher charges, the focusing of particles can be effected, providing the particles are deflected to the analyser outer electrode. It determines the construction of the analyser. The analyser is concentric with the charger, the charged aerosol enters cocylindrically near the inner electrode with a cylindrical clean air sheet surrounding the aerosol. The aerosol is detected at the outer electrode.

Certain conditions must be met to make the analyser reliable.. To avoid corona discharges in the analyser, the electric field should be of limited value [Matisen 1988]:

$$E_A < 1 \div 2 \text{ kV/cm} \quad (7.18)$$

The air speed should also be limited to [Nicholson 1988] about

$$V_F < 1 \div 2 \text{ m/s} . \quad (7.19)$$

A higher linear velocity of the air flow may bring about the effect of particle removal from the electrodes.

7.4.1. Analyser dimensions

The analyser, the largest component of a spectrometer determines the geometrical sizes of the other components as well as the total size of the spectrometer. The analyser size is determined by the adequate amount of the aerosol flux and the required particle electric mobility range. The lowest electric mobility of the particles to be analysed and the limits, set upon the electric field density and the linear velocity of the air, together determine the maximum analyser size and the electric capacitance.

Assuming that the slit S between the analyser electrodes is narrow, the radius of inner electrode R_1 is close to the that of outer electrode R_2 , the surface area of the slit can be expressed as

$$S_A = \pi(R_2^2 - R_1^2) = 2\pi R_A \Delta R_A . \quad (7.20)$$

The total capacitance of the analyser C_m can be estimated as

$$C_m = \frac{L_A}{2 \ln \frac{R_2}{R_1}} = \frac{L_A R_A}{2 \Delta R_A} , \quad (7.21)$$

L_A being the total length of the analyser electrode.

It can be derived that

$$2 \pi R_A \Delta R_A = \frac{F}{V_F} \quad (7.22)$$

$$C_m U_A = \frac{L_A R_A E_A}{2} . \quad (7.23)$$

The two equations with three parameters R_A , ΔR_A and L_A , allow to set further limitation, e.g., to fix the total analyser length L_A .

Actually, there are more free parameters in the analyser. For example, the electrodes need not be right cylinders, but they can be only concentric, which can be used for customizing the analysis of the particles of different mobility.

In a one-channel measuring device the particle mobility distribution is usually measured by varying the voltage on electrodes [EAA]. In fact, full range of the mobility is classified but only one fraction is measured at a time, other fractions are deposited on electrodes and lost. As mentioned in Section 3.5, the deposition of a particle depends on the value of the analyser capacitance measured from the inlet to a certain section (Eq. 3.26). The particles are distributed according to the analyser capacitance to be taken as an output parameter of the spectrometer (Eq. 4.1). To improve the distribution of particles on the scale of the analyser geometrical length, the electrode radii can be varied. As only the capacitance product to a voltage value is of importance in mobility analysis (Eq. 3.25), additionally the electrodes can be split into sections and supplied with different voltages [Mirme and Peil 1983, Mirme *et al.* 1984] which makes it easy to reform the distribution scale.

7.5. Selection of spectrometer construction parameters

The mean values and nonhomogeneities of charging parameter α and electric field intensity E can be estimated for an aerosol flux in the charger and the flux in-to-out ratio (see Sect. 5.6.5) by Equations (3.14, 3.15) and (7.15, 7.16). As the particle charges can also be calculated (Eq. 3.20) for any radius of the charger, the mean particle charge and the half width of the charge distribution (Eq. 5.3, 3.13 and 3.11, 3.12, 3.5) at the outlet of the charger, can be found. The analyser parameters can be estimated (Eq. 3.28 and 3.29) for certain voltage U . The limitations (see Sect. 7.4) can be taken into account by considering Equation (3.25).

Consequently, the half width of particle distribution (Eq. 5.15) and the total resolution of the spectrometer of certain parameters (Eq. 5.13) can be estimated as well as the critical time for the charger by Equation

(5.20), the particle losses (Eq. 5.24) and consequently, the sensitivity (Eq. 5.25). The total resolution and sensitivity of the wide range spectrometer can be estimated by Equations (6.2) and (6.3).

This way we can have the spectrometer resolution estimate as a function of a number of spectrometer construction parameters. The spectrometer sensitivity can be expressed through similar function. Also the expressions of other estimates can be found. The final selection of the spectrometer construction parameters can be made by analysing these functions on the basis of some optimality criteria.

In this paper the particular cases of the resolution as functions of some spectrometer parameters are presented, the other parameters are considered fixed for the sake of simplicity. As the resolution at the particle sizes of about 200 nm is the most critical one with the diffusion charging of the largest effect, the are taken for the basis.

When selecting the values of the spectrometer parameters, we have to remember that an increase of resolution usually corresponds to a decrease of sensitivity and visa versa. Thus, some compromises are to be found in selecting the parameters.

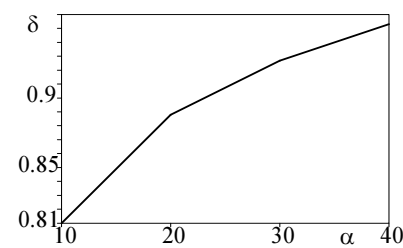

Fig.7 Diffusion spectrometer resolution vs. charging parameter

The dependence of the resolution on the charging parameter is presented in Figure 7. The values larger than 20 give sufficient enough resolution. The value of about 30 can be considered good, as higher values effect increase of particle losses due to higher electric field density (Eq. 5.20, 5.22).

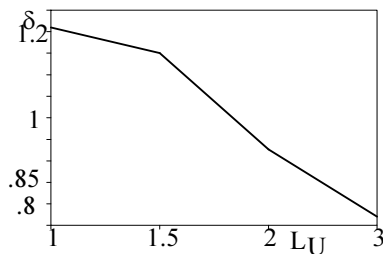

Fig.8 Resolution of D-spectrometer vs.in/out ratio of charger. Aerosol flux into charger is 400ccm/s

The resolution dependence on aerosol and air fluxes is presented in Figure 8 and 9. We have to keep in mind that a small aerosol flux decreases sensitivity.

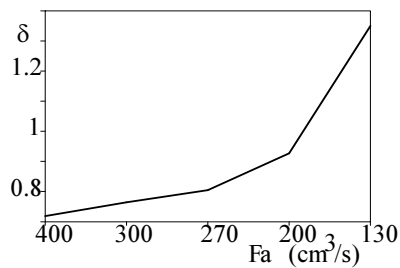

Fig.9 Resolution vs. aeros. flux to analyzer Total flux of analyzer =800 cm³/s. Aerosol flux into charger=400 cm³/s

As can be seen in Figures 8 and 9, the flux of about 200 cm³/s and the in-to-out ratio of aerosol of about 2 are optimal for the charger.

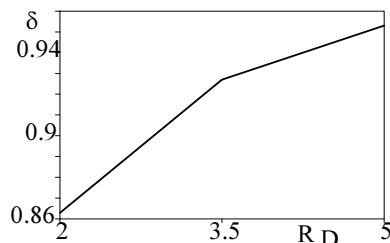

Fig.10 Dependence of resolution on radius of diffusion charger

The dimensions of the spectrometer can be taken into account as demonstrated in Figure 10.

Actually, the question of the geometrical size of the spectrometer is a complex one and the limitations of the spectrometer total size are also of importance.

The following main technical parameters of an electric aerosol spectrometer for atmospheric aerosol studies can be derived as optimal ones on the basis of the analysis:

- charging parameter =30
- chargers output aerosol flux = 200 cm³/s
- aerosol input-to-output ratio = 2
- total aerosol and air flux in analyser = 800 cm³/s

The total resolution of the spectrometer with a wide measurement range (Fig. 6) is estimated according to Formula (6.2). To make the spectrometer (Fig. 5) more sensitive, the sensitivity in large particle range is to be raised, for example, by increasing the aerosol flux in the field charger and by reducing the air flux in the analyser as preserving the analyser geometrical sizes. Some reduction of the resolution is of no importance in that size range.

8. SPECTROMETER SIGNAL PROCESSING AND SPECTRUM EVALUATION

8.1 Parallel measurement principle

A spectrometer record is formed from the spectrometer signal measurements at a set of record argument values. There are two kinds of instruments in use.

In a scanning type (sequential) spectrometer the analyser voltage is considered as the record argument. It is scanned step by step or gradually through the voltage range and the particle signal is measured at each step or at certain values of the voltage. At a certain moment of time only particles of a certain mobility are measured and the aerosol distribution measurement is distributed over time but located in space as it is registered by one recording device.

As particles are classified and deposited on an analyser electrode accordingly to the analyser electric capacitance, reflecting the particle mobility, the aerosol record can be determined by measuring the distribution of aerosol particles on the electrode.

In a parallel type spectrometer, the electrode is splitted into a number of separate sections. Each section provides a signal equivalent to the signal at a step of a scanning type spectrometer. The signals of the sections can be detected simultaneously and no scanning in time is needed. We will consider that the section is the first component of a spectrometer measurement channel, the other components being a signal detector and recording devices. The channels can work parallelly and the signals needed for distribution calculation can be measured simultaneously in all the channels.

The advantage of the first type of spectrometers is simplicity. The measuring device can be a complicated and expensive one of high performance as only one device is needed. A parallel spectrometer is of complicated structure. If only one measuring device is used, a complicated system of collecting channel signals and commutating them to the measuring device [Tamm et al. 1973] is required. Each channel having a measuring device of its own, makes a complicated commutator unnecessary, but calls for a cheap and therefore, of low performance measuring device.

A disadvantage of the sequential measurement method is its limited the use of only a small fraction of available information at a time. In stationary situations of aerosol of stable composition, the method results in

a prolonged measurement time. Measuring an aerosol of fast varying distribution, this may result in significant distortions of the record as the sections of the mobility range measured can actually represent different aerosols. Highly specific spectrum deformations can occur because the record, containing the information of several parts of spectrum in one record element, become deformed in an unpredictable way, not accounted by the apparatus equation, and the result of the transformation them into the spectrum will be also unpredictable [Mirme and Tamm 1991]. The resulting errors can be many times that the actual variations in aerosol concentration.

The gradually scanning type of aerosol spectrometer [Wang and Flagan 1989] has a shortened measuring time but it is still a sequential instrument as it still uses only a small fraction of the available information at a time.

A parallel type instrument can present the true average spectrum of the measurement period even for nonhomogeneous and varying aerosol as the signals of all channels can be recorded during the full period of measurement and the fluctuation of the result can be the statistical variations of average spectrum of the period only. As the averaging time is usually well controlled, it is possible to study the statistical characteristics of the aerosol short scale variations by varying the averaging time.

8.2 Signal recording in aerosol spectrometry

A recording device of the spectrometer is to provide us with the signal records, which correctly reflect the aerosol spectrum measured. Preciseness of measurement is the main characteristic and can be considered in two parts; the sensitivity determined by the noise of low level signals and the dynamic range expressed as the amplitude of the concentrations measured with acceptable errors of nonlinearity.

A great number of aerosol instruments, (e.g., CNC) measure the aerosol concentration by counting the particles. The method has the maximum of sensitivity and is highly suitable for use in clean rooms. The sensitivity of CNC is limited by the statistical error of counting. It is not very suited for atmospheric measurements because of its limited dynamic range accounted for by particle coincidence in the counting volume, and a limited size range as the effectiveness of small particle condensation growth decreases. The CNC being of complicated construction, is almost impossible to use in a parallel spectrometer.

Another method of signal recording is used in EAA that measures an electric current induced by the charged particle flux. In constant charg-

ing conditions the current is a linear function of the particle concentration.

A well-known way of signal recording is to capture the particles in an electrometer connected a Faraday cup type filter. The induced electric current exactly equal to the charge flux entering the cup per unit of time is recorded by the electrometer.

As an electrometer still cannot measure a single elementary charge, the sensitivity of the electric spectrometer, sufficient for normal atmospheric aerosol measurements (Fig. 5), is much lower than the sensitivity of the particle counter.

The way of measurement based on measuring the charged particle deposition onto a (conductive) electrode is in principle similar to the Faraday cup method, as the electrode can be treated as an open cup.

The electrode method is technically the simplest one. For the parallel measuring of the aerosol spectrum the analyser electrode can be split into a number of separate electrodes providing the necessary distribution of electrode capacitance (Eq. 3.26), the induced electric current can be collected and the collected charge of each electrode can be periodically recorded [Tamm et al. 1973].

The shortcoming of the method is the particle deposition going on in an electric field, the field fluctuations inducing extra electric current distorting the signal which considerably lowers the sensitivity of the instrument [Mirme 1984]. Also the charge collection and the signal recording process is accompanied by noise.

8.3. Electrometric detector for the aerosol spectrometer

The electric currents of electrodes are to be measured simultaneously in the parallel spectrometer. When currents are collected into electric capacitors and the capacitor charges are measured by commutating the capacitors to a sensitive electrometric amplifier input [Tamm et al. 1973] a single electrometer is needed, but the commutator and the capacitors are to be of extra quality, free of self-generated charges. Some errors can be occur due to change of electrode potentials during the current collection.

An operational amplifier (integrating amplifier) based charge collector can prevent errors. An ordinary amplifier provided with an MOS type transistor in the input with a resistor-capacitor feedback circuit [Miller 1981] is good for the purpose. The change of the electric potential takes place in the amplifier (electrometer) output only. An ordinary

commutator of a data-taking system can be used for recording the output signals.

8.4. Processing measurement signals

The output signal of a channel is a sum of an aerosol signal and several disturbing signals. According to the analysis by Mirme (1984), the main sources of distortions are the analyser electrode voltage source and the parasitic currents in the amplifier input. To reduce the distortions effected by the voltage, the less noisy source can be used as only one is needed. Reduction of the parasitic currents in the parallel spectrometer requires a large number of high performance amplifiers, which will be expensive.

The effect of parasitic currents can be much reduced by a modulating the charged aerosol flux [Tammets 1980]. The parameters of the chargers are periodically changed producing a pulsating charged particle flux in the analyser and an alternating useful signal at the output. The signal processing for this method is discussed in a paper by Mirme (1983).

The modulation works by as changing the useful signal frequency spectrum without affecting the parasitic current spectrum. The useful signal can be effectively differentiated from parasitic ones by a method of synchronised receiver [Kurotshkin and Murin 1975], for example. According to the method the best possible estimation U_{est} of the signal U is expressed by the formula (8.1) provided the known signal pattern U_{pat} .

$$U_{est} = \int_{U_{pat}} U dt . \quad (8.1)$$

The method is proved to be the best possible one, provided the noise is uncorrelated in time.

The noise being initially uncorrelated is deformed by a transmission function $K_{U/I}$ of the electrometric amplifier as

$$\frac{U_{e,out}}{I_{e,in}} = \frac{R_e}{1 + i\omega \tau_e} , \quad (8.2)$$

where R_e is feedback resistance and $\tau_e = R_e C_e$ is the integration constant of the amplifier. For the optimal use of the synchronised receiver method the, initial character of noise is to be restored by applying a correcting filter of the inverse to Equation (8.2) transformation function.

Taking into account the periodicity of the readings, the i -th reading can be restored according to the formula [Mirme 1983]:

$$U_{e,f}(i) = U_e(i) + \frac{\exp\left(-\frac{T_i}{\tau_e}\right)}{1 - \exp\left(-\frac{T_i}{\tau_e}\right)} [U_e(i) - U_e(i-1)] \quad (8.3)$$

Here T_i is the time between readings i and $i-1$. The result is free of the restrictions set in the paper by Tammet (1980).

The estimate of the useful signal at the output of the electrometer can be presented by the formula [Mirme 1983]:

$$U_{est} = -\frac{1}{2n_0} \sum_{i=1}^{n_0} U_{e,f}(i) + \frac{1}{n_m} \sum_{i=n_0+1}^{n_0+n_m} U_{e,f}(i) - \frac{1}{2n_0} \sum_{i=n_0+n_m+1}^{2n_0+n_m} U_{e,f}(i) \quad (8.4)$$

The aerosol flow is modulated in time according to the following sequence; n_0 readings without aerosol charging (no useful signal), n_m readings with the charged particle deposition to the electrodes and again n_0 readings without charged aerosol.

The error can be estimated by studying the deviation of the measured signal $U_{e,f}$ from its mean value.

The formula (Eq. 8.4) is aimed at the maximum of sensitivity and signal-to-noise ratio for mean aerosol concentration of the measurement time, the variation of aerosol concentration is related to error.

To follow fast changes of aerosol concentrations they are to be differentiated from the spectrometer noise possible at higher aerosol concentrations. The parasitic signal, effected by the parasitic current can be estimated by the charged aerosol free readings, the useful signal being the difference of a reading and a parasitic signal estimate. As the estimation can be performed for any charged aerosol reading, the aerosol distribution can be calculated for each reading. As the readings can be taken with only a few second intervals, the changes of aerosol concentration in few seconds can be followed.

8.5. Formation of the apparatus record

The spectrometer record ψ can be formed from the channel signal estimates. To make the record independent of the particular electrometer characteristics, the electric current induced by the charged aerosol flux into the measurement channel, can be used as the record element. The i -th record element can be estimated by the channel signal $U_{est,i}$ (Eq. 8.4) estimate and the known amplifier feedback resistance $R_{e,i}$ by Formula [Mirme 1983]:

$$\psi_i = \frac{U_{est,i}}{R_{e,i}} . \quad (8.5)$$

As each channel has an independent measuring device, the channel noises can be considered mutually noncorrelated and the covariation matrix of record D should be a diagonal one with the diagonal elements being the channel signal dispersion estimates recalculated by another, similar to (8.5) formula.

An example of the apparatus record is presented in Appendix. The output file of the spectrometer includes also some extra information allowing to evaluate the correctness of the record.

8.6. Evaluation of the spectrum

The spectrum can be estimated by the apparatus record and the known apparatus function by solving the apparatus equation (3.1). As shown above, only an approximate solution is possible, for example, by solving the matrix equation (4.7).

The classic solution is given by the method of least squares by the formula:

$$\varphi = (H^T D^{-1} H)^{-1} H^T D^{-1} \psi . \quad (8.6)$$

The exactness of the spectrum is given by its covariation matrix:

$$V = (H^T D^{-1} H)^{-1} . \quad (8.7)$$

Probably the best estimate would be that of the maximum probability for a certain record. The probability of the solution (Eq. 8.6) depends on the character of errors and equals to the maximally probable estimate if the errors are normally distributed [Tammet 1975].

As shown by Mirme (1984), the spectrometer noise consists of the noise of many independent sources, most of them probably of the normal distribution. Therefore, the normality of the total error distribution can be assumed, and consequently, the maximum probability of the solution (8.6).

As the least square method accounts for the record elements proportionally to their weights, i.e., inverse dispersions, both, the record elements as well as their dispersions (covariation matrix) are to be estimated correctly.

Full linearity of the method can be considered as a disadvantage, as the negative values of the spectrum elements are not rejected. The solution

(8.6) is not of maximal probability, and a better solution without the negative values, should exist. The negative values becoming essential at low aerosol concentrations indicate a low reliability of the results. This can be interpreted as a shortage of information in the record for a detailed spectrum calculation and seen in the light of the discussion in the previous sections, the number of spectrum elements should be reduced, for example, by smoothing. That will reduce the amount of information required and, consequently, the probability of negative values in the spectrum.

Two reasons for avoiding the application of the solution (8.6) to spectrometry can be pointed out; first is a nonlinear spectrometer that cannot be described by a linear equation (3.1), second is if the error distribution differs essentially from normal.

The linear solution is often rejected not because of the nonlinear spectrometer or error distribution but because of a nonlinear spectrum model used. Nonlinear solutions can impose sophisticated restrictions on possible shapes of the aerosol spectrum, but the optimality of these solutions may be problematic.

We do not discuss the nonlinear models because the type of the spectrum model is an abstract notion, in fact. Practically a linear model and the solution (8.6) of proved optimality are always applicable.

The spectrum φ being known, any type (number, surface, volume, etc.) of aerosol distribution can be calculated using the relation (Eq. 4.5) and standard distribution converting procedures.

9. THE CONSTRUCTION OF AN ELECTRIC AEROSOL SPECTROMETER OF TARTU UNIVERSITY.

The design of the Electric Aerosol Spectrometer (EAS) is depicted in Figure 11 [Mirme *et al.* 1981, Mirme *et al.* 1984b]. EAS was designed on the full parallel measuring principle [Tamm, Mirme, Tammet 1981, Mirme, Tamm, Tammet 1983].

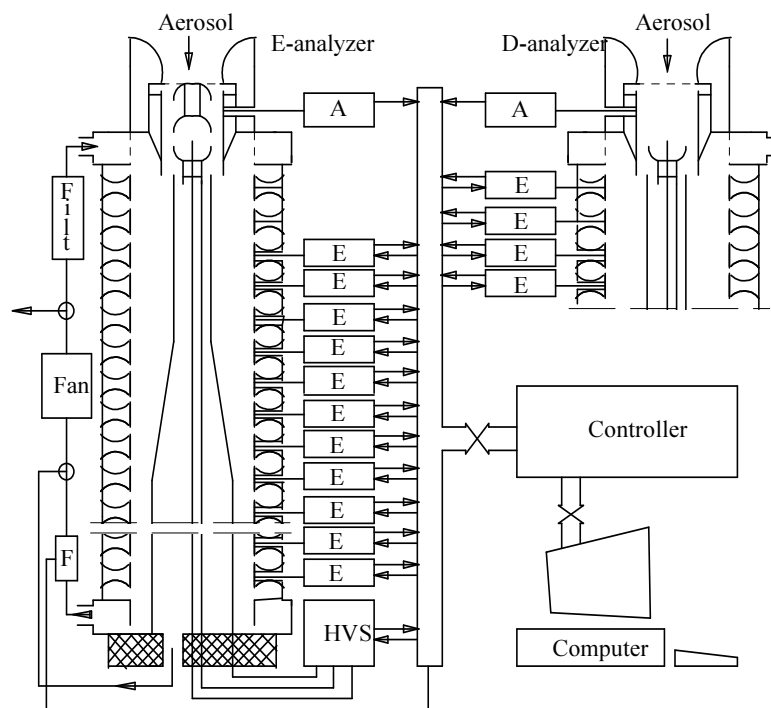

Fig.11 Diagram of Electric Aerosol Spectrometer of Tartu University

D-analyzer - charger and analyzer of diffusion charging

E-analyzer - charger and analyzer of field charging

A - corona current amplifiers

E - electrometric amplifiers

HVS - high voltage supply

F - flowmeter

Filt -air filter

An EAS consists of two parallel systems. The analyser with a diffusion charger (D-analyser) serves to measure small particles, the analyser with field charger (E-analyser) measures in the large particle range, the work of both analysers influenced by the particles of the other range. The reciprocal correction of the measurement data will be made mathematically.

The principle of parallelism is substantiated by the operating principle of the analysers which classify the all aerosol into a number of parallel channels. The aerosol is moved on in the analysers by a built-in fan which simultaneously removes also the aerosol of extra charging zones and generates analyser clean air sheets. The regimes of the chargers are stabilised by feedback circuits. The time uncertainty of measurement is reduced by measuring the same aerosol sample, synchronously with its movement on in the analyser. A special controller has been designed to control the measurement and record data. The maximum resolution of the electrometric signal is 0,25 mV making about $2.5 \cdot 10^{-16}$ A on the scale of the aerosol electric current. The main spectrometer parameters such as charging currents and air flow rates are also controlled.

The spectrometer has been subjected to several modifications improving its reliability and handiness. The first version did not have the on-line connection with the main computer [Mirme et al. 1979, Mirme, Tamm, Tammet 1981, Tammet, Mirme, Tamm 1983]. It was modified later [Mirme 1982, Mirme *et al.* 1984a]. The on-line operation with a computer allows to apply complicated processing, significantly increasing the reliability and accuracy of the computer [Mirme, Tammet, Bernotas, Tamm 1984a].

10. METHODS OF SPECTROMETER CALIBRATION

10.1 Calibration task

The transformation of the spectrometer measurement data into the aerosol spectrum is based on a spectrometer mathematical model, the correctness of which is necessary condition for the effective transformation and so for full utilisation of the spectrometer potency. When the selected model does not reflect the spectrometer then the results do not reflect the aerosol. Sometimes the calculated spectra can be rejected as physically impossible. In the worst case the errors are not discovered and even the physical model of the processes under study can become deformed. As shown in the paper by Noppel (1990) aerosol distribution calculations by a simplified model can result in a systematic increase of aerosol concentration of about 80-100 nm, which can deform the monomodal aerosol distribution into a two-modal one.

The building of the spectrometer mathematical model, i.e., the spectrometer calibration is the last step in the spectrometer design. As the model is expressed by the kernel H of the apparatus equation (3.1), the calibration is to provide the necessary data and calculate the kernel, including an estimate of the model accuracy expressed by the errors of the kernel H . The error estimate is often omitted, as it is probably assumed that the calibration errors are negligible in comparison with the measurement errors.

10.2 Spectrum basis

Spectrometer quality in the present discussion is evaluated on basis of the fraction model of aerosol. As the simple fraction model presents the aerosol distribution as a discrete one while in fact it should be continuous and rather smooth because of the low selectivity of particle generation and evolution processes to the particle size, a linear-sectioned spectrum model has been put forward by Tammet (1980a) as a model of simple description and yet reflecting more precisely the processes in atmospheric aerosols. In this model the distribution function $\varphi(x)$ is presented by sections of a line (polyline), the endpoints of the sections being the distribution nodes (Fig. 12.).

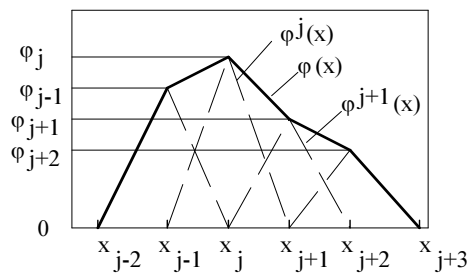

Figure 12. Linear sectioned spectrum model

The distribution can be formed by linear superposition of triangular elementary distributions of unit height $\varphi^j(x)$ (Eq. 4.5), the ordering number of an elementary distribution j being the ordering number of a

node and the node argument x_j being the argument of a triangle vertex. The margins of the triangle base are at the zero line with the arguments, equal to the arguments of the neighbouring nodes (x_{j-1}, x_{j+1}). The values of the spectrum vector φ_j elements present the spectrum concentration densities at the vertices.

As the model approximates the particle distribution density only linearly between the nodes, the distribution of a very monodispersed aerosol can be described with significant errors. On the other hand, the spectrometer has a limited capacity of measuring narrow aerosol distributions because of its limited resolution capacity. To balance the model with the spectrometer, the set of nodes is to be selected in accordance with the resolution characteristics, i.e., it is to correspond to the set of fraction limits.

10.2.1. Adaptation of the spectrum model to the atmospheric aerosol spectrum

Approximation errors of a model can be reduced if the knowledge about the typical spectrum to be measured is taken into account in the model.

A particle concentration rapidly decreasing with the increasing particle size is typical of atmospheric aerosols. According to the Junge law the density of a number distribution is proportional to the inverse radius of the fourth power [Junge 1955]:

$$f(r) \sim \frac{1}{r^4} . \quad (10.1)$$

As proposed by Tammet (1980a) the distribution (Eq. 10.1) can be presented by a straight line crossing the zero point, by taking the inverse radius as a model distribution argument and defining the distribution according to the formula:

$$\varphi(x) = r^3 f(r) , \quad x = \frac{1}{r} . \quad (10.4)$$

The linear-sectioned spectrum model can approximate the distribution (10.4) without errors, also the amplitude of the numerical values of the spectrum can be small which provides small computing errors.

10.3. Calibration methods

A number of calibration methods, as a theoretical method, a method of monodispersed aerosols, a method of analysis of the deposited particles on electrodes, a direct method, a parametric method and any combination of them [Tamm et al 1992] can be applied in an aerosol spectrometer calibration.

10.4. Theoretical calibration

The spectrometer apparatus function can be calculated on the basis of the theoretical information concerning the physical processes going on in the spectrometer, and its technical characteristics (see Sect. 4.1).

If the probability of the particle of radius r and of the electric charge q is expressed by $P(q,r)$, the current induced by the particles in the electrode can be expressed by the formula [Tamm et al 1983]:

$$I(q,i) = qe \int G(i,k(q,r)) P(q,r) f(r) dr, \quad (10.5)$$

where G denotes the apparatus function of the i -th section of the analyser [Tamm et al 1970] being equal to the aerosol flux of electric mobility k to the i -th electrode. $k(q,r)$ denotes the mobility of a particle of the radius r and the charge q .

The total current of the electrode equals to the sum of the currents of the all charges:

$$I_i = \int q G(i,k(q,r)) P(q,r) f(r) dr. \quad (10.6)$$

As shown before, Equation (3.1) as well as Equation (10.6) cannot be correctly used in practical determination of the distribution $f(r)$. The transformations are to be started by introducing the spectra basis (4.5) with the formula (see Sect. 4.4):

$$\psi_i = \sum \varphi_j \int G(i,x) \varphi^j(x) dx. \quad (10.7)$$

Comparing the formula with Equation (10.6), an equation for the apparatus matrix elements H_{ij} can be derived as

$$H_{ij} = \int_0^\infty \sum_q G(i, k(q, r)) P(q, r) \varphi^j(r) r^{-3} dr \quad (10.8)$$

The elements can be calculated and, consequently, the spectrometer can be calibrated provided the characteristics of the analyser G , the dependence of the mobility on the particle size and the charge k , also the probability of charging in the instrument $P(q, r)$ are known with the required accuracy. Formula (10.8) has limited use as it includes a number of theoretically and technically poorly determined parameters. The determination of the probability function $P(q, r)$ is the most difficult problem as the detailed knowledge of charging probability in the charger, depending upon the detailed technical characteristics of the charger, is required.

10.5. Experimental calibration

10.5.1. Calibration with test aerosols

The most direct way of calibration is to measure a set of aerosols with distributions exactly equal to the elementary distributions $\varphi^j(x)$. The aerosol spectrum of each case has only one element that is not equal to 0 in that case (Eq. 4.5) and according to the apparatus equation in its matrix form (Eq. 4.7), the record will be exactly proportional to the corresponding column of the apparatus matrix, the set of aerosols determining the full apparatus matrix. The question is how to generate such a set of aerosols.

In practice a method of monodispersed aerosols can be used [Kikas *et al.* 1985]. A monodispersed aerosol with a very narrow distribution can be treated as approximating the delta-function and then the apparatus record in Equation (3.1) will be equal to the kernel $H(i, r)$ (see Sect. 3.1).

Measuring a number of monodispersed aerosols of different sizes covering the full size range of the spectrometer and assuming the continuity of the kernel, an approximation formula can be set up as follows;

$$H(i, r) = H[i, a_1(r), a_2(r), \dots] \quad (10.9)$$

The matrix elements can be calculated by the formula:

$$H_{ij} = \int_0^\infty H(i, r) \varphi^j(r) dr \quad (10.10)$$

The key question of the calibration is the availability of a good aerosol standard of monodispersed aerosols. The sources of monodispersed

aerosol with well-known parameters, e.g., mean particle size, total concentration, distribution width [Liu, Pui 1974a] are required.

The Hewitt (1957) differential mobility analyser based aerosol classifier [Knutson and Whitby 1975] is widely used as an aerosol source in small particle range. The classifier is one of the few instruments, which can serve as absolute standards [Tamm, Kikas, Mirme 1992].

The vibrating orifice generator [Berlung and Liu 1973] is a high performance aerosol source in large particle range [Tamme and Koppelmaa 1987]. The vibrating needle generator has also been used for the purpose for some time [Visnapuu, Mirme 1979].

Various aerosols like NaCl and AgI condensation aerosols [Bernotas *et al.* 1979, Kikas *et al.* 1988, Mirme, Kikas, Tamm 1991], also dioktylphtalate aerosol [Tamm 1973] and moss spores have been used in practice [Tamm *et al.* 1986].

The monodispersity of aerosols has been improved with an aerosol classifier providing half-widths of aerosol distributions not exceeding 10% [Kikas, Susi, Tamm 1982, Kikas, Tamm 1982, Kikas *et al.* 1984]. The studies directed to improvement of the aerosol quality have been continued later on [Tamm, Langus, Mirme 1987, Kikas 1987, Tamm 1992].

A practical approximation formula for the kernel of the spectrometer apparatus function was defined as [Kikas *et al.* (1985)]:

$$H(i,r) = a_{i,0} + a_{i,1}r + a_{i,2}r^2 + a_{i,3}r^3 + a_{i,4}r^4, \quad (10.11)$$

the factors a determined by adapting it to the apparatus records of the set of monodispersed aerosols.

The matrix was tested by measuring various aerosols. Aerosols of the small particle range measured well enough. Aerosols of the large particle size measured with errors a few times larger than the concentration values and in some cases there were significant phantom concentration peaks in the small particle range. The results could be explained by the lower quality of the monodispersed aerosols in the large particle range (lower monodispersity and errors in the determination of the aerosol parameters) and the quality of the approximation formula (10.11). Visualisation of the distribution data with very nonuniform error values (see sect. 5.6) is also important in evaluation of the results as the data are to be considered in accordance with their statistical insignificance, i. e., their accuracy.

The method of monodispersed aerosol requires that the aerosols should be of very good monodispersity. The selection of the approximation formula is difficult because of the discrete electric charge and a number of other characteristics expressed in more complicated way.

10.5.2. Calibration based on the analysis of particle deposit

A unique feature of the spectrometers using the deposition of particles on electrodes, is the calibration possibility by the analysis of the particle deposits, for example, under the electron microscope [Tammet 1983a]. Opposite to the method of monodispersed aerosols, aerosols of a wide distribution, covering almost uniformly the full range of particle sizes are required.

Studying the dependence of a record element on an aerosol spectrum element (Eq. 4.6) an apparatus matrix element can be found expressed by the formula:

$$H_{ij} = \frac{\psi_{ij}}{\varphi_j} , \quad (10.12)$$

where ψ_{ij} is the signal caused by the j -th spectrum element of the concentration φ_j , in the i -th channel.

The signal is a function of the particle concentration and the charge. The concentration can be calculated by deposit data analysis, as the particle spectrum can be determined directly for each channel from the deposit, taking into account the aerosol flux. The charge can be calculated from the particle size and the known value of channel mobility. The concentration of the spectrum φ_i at the input of the spectrometer, can be estimated as a sum of the relevant concentrations over the analyser all sections corrected by the factor of particle loss. The full formula of the apparatus matrix elements is given in the paper by Tammet (1983a).

In practice, the main problem not solved yet, was the determination of the particle size distribution deposited on the electrodes, with a sufficient accuracy in the wide size range. Then electron microscope was not good enough for the purpose. Also the difference between the sizes, measured electron-optically and the electro-aerodynamic size, being in effect in the spectrometer, is the source of errors as well as the factor of particle loss.

10.5.3. Direct calibration

The method of least squares was selected as the optimal method of spectrum calculation. The same method can be applied to the spectrometer calibration [Mirme 1987].

Let us have l records Ψ^k , ($k=1..l$) of different aerosols. They need not to be monodispersed, but their spectra vectors Φ^k must be known.

A generalised apparatus equation can be composed;

$$\begin{array}{ccccccc}
 \begin{array}{c} \psi_1^1 \\ \vdots \\ \psi_n^1 \end{array} & \cdot & \begin{array}{c} \psi_1^l \\ \vdots \\ \psi_n^l \end{array} & \cdot & \begin{array}{c} H_{11} \\ \vdots \\ H_{nm} \end{array} & \cdot & \begin{array}{c} \phi_1^1 \\ \vdots \\ \phi_m^1 \end{array} \\
 \vdots & & \vdots & & \vdots & & \vdots \\
 \begin{array}{c} \psi_1^n \\ \vdots \\ \psi_n^n \end{array} & \cdot & \begin{array}{c} \psi_1^1 \\ \vdots \\ \psi_n^1 \end{array} & \cdot & \begin{array}{c} H_{11} \\ \vdots \\ H_{nm} \end{array} & \cdot & \begin{array}{c} \phi_1^1 \\ \vdots \\ \phi_m^1 \end{array}
 \end{array} , \quad (10.13)$$

or a equivalent matrix equation;

$$\Psi = H \Phi , \quad (10.14)$$

the records and spectra vectors being the columns of matrixes Ψ and Φ , respectively. Equation 10.14 can be transposed into

$$\Psi^T = \Phi^T H^T . \quad (10.15)$$

Equation (10.15) can be decomposed into the equations of

$$\Psi^j = \Phi^T H^j , \quad j = 1 \dots n . \quad (10.16)$$

They are similar to the apparatus equations but they also have differences; the record vector Ψ^j is formed from all the l record elements of the same, i -th channel, the spectrum to be found is the i -th row of the apparatus matrix. As the statistical independence of both, the measurements and the measurement channels is assumed, errors are presented only by dispersions and form a diagonal covariation matrix D^j . The n equations (10.16) provide for the calculation of all the n apparatus matrix rows and so the full matrix can be found.

The approach of solving the apparatus equation is also valid here. Thus, the optimal solution of Eq. 10.16 can be expressed by the formula:

$$H^j = (\Phi(D^j)^{-1} \Phi^T)^{-1} \Phi(D^j)^{-1} \Psi^j , \quad j = 1 \dots n . \quad (10.17)$$

The accuracy estimation of the apparatus matrix rows in the form of covariation matrixes is provided:

$$V^j = (\Phi(D^j)^{-1} \Phi^T)^{-1} , \quad j = 1 \dots n , \quad (10.18)$$

which is an important advantage of the method as exactly the covariation matrixes are required for the apparatus matrix error account (Eq. 10.19).

10.6. Use of information sources

The direct calibration method uses the information presented in the form of spectra, apparatus records and their dispersions. The method gives the

best possible solution when the errors have normal distribution. It means that such information is fully used by that method. The method can be applied to calibrate the spectrometer by aerosols of known distribution. It can also use any other information about the spectrometer and aerosol processes in the spectrometer provided the information can be presented in the form of aerosol spectra and respective records, for example, by simulating them mathematically. In fact, there is much information concerning the technical characteristics of the spectrometer and also much theoretical knowledge that cannot be presented directly in the form of spectra and records. However, the simulation of the spectra and the corresponding records can be partly possible, the contribution of ill-known parameters can be included in errors.

10.7. Parametric calibration method

The idea of a combined calibration method is discussed in the paper by Tammet and Noppel (1984) and in the paper by Noppel and Tammet (1987).

The method makes use of the information in parametric form by describing the elements of the apparatus matrix as functions of a set of parameters. Calibration means the determination of these parameters. The parameters were used also in monodispersed aerosol method but they were introduced only in very formal way there (Eq. 10.11). By the parametric calibration method, the parameters are selected in accordance with the spectrometer technical and regime parameters. The well-determined parameters can be fixated, the others are to be estimated from the fitting of measured and simulated records of the aerosols of the known spectra. The statistically weighted difference between the statistical parameters of the actual and the simulated records is minimised by varying the values of the parameters [Noppel 1989]. Thus, the all; theoretical, technical and experimental information can be used in the spectrometer calibration.

10.8. Summary of calibration methods

The aerosol deposit analysis method is fully based on measurements. In practice correct determination of the particle distribution on the electrodes in a wide size range and factor of the particle loss is a difficult task calling for much theoretical assumptions. The method may be good if certain features of the spectrometer are studied, it is also of value as an additional information source for other methods.

The direct method calls for complicated reformation of technical and theoretical parametric information. If it is based on calibration aerosols,

a good net of aerosol sources of well-defined parameters, covering the full range of particle sizes is required.

The parametric method could be probably the best one as it can easily use all kinds of information because of the nonlinearity of the method. A disadvantage of the method can be pointed out as the information in this method is presented in form of a set of parameters to be converted into an apparatus matrix. Thus, the matrix may be incorrect even if the parameters are the correct ones as the set of parameters is surely incomplete and some important parameters may be missing.

In contrast, the direct method utilises all the information of the calibration measurement data and can use any other information presented in the form of spectra and apparatus records. Also the correct accuracy estimate of the apparatus matrix is available. No extra conversion of apparatus matrix is required.

10.9. Accounting for calibration errors

In most measurements a precise apparatus matrix is assumed, and only record measurement errors are considered. There are very few cases when the matrix errors are considered. If the spectrometer is well calibrated, matrix errors may be neglected in comparison to the measurement errors in general, but nevertheless, they can be of importance in particular cases.

There are methods which take the errors of apparatus matrix elements into consideration [Tikhonov 1985, Tikhonov, Arsenin 1986, etc.]. A theoretical method for EAS error account was developed by Noppel [Noppel 1978, 1982].

There is a similar method of matrix error accounting developed by [Mirme 1988]. It is based on the availability of the covariation matrixes of the apparatus matrix rows (Eq. 10.18) calculated by the direct method.

The effect of the matrix errors can be expressed through the record errors according to the formula:

$$d_{h,ii} = \varphi^T V^i \varphi , \quad (10.19)$$

where φ is the known spectrum. Thus, the matrix errors are included if the diagonal elements of the total covariation matrix are estimated as sums of the dispersions:

$$d_{\Sigma,ii} = d_{ii} + d_{h,ii} \quad (10.20)$$

and the spectrum calculated with the corrected (Eq. 10.20) covariation matrix, takes into account also the calibration errors. The initially unknown spectrum (Eq. 10.19) can be estimated iteratively, by taking the result of an iteration as the spectrum for recalculation of matrix errors (Eq. 10.19) in next iteration.

As the calculation of a spectrum is mathematically similar to the direct calibration method, its error accounting method can be applied also for accounting the errors of the apparatus matrix [Mirme 1988, Mirme and Tamm 1993].

The method provides the full account of uncertainty of determining the calibration aerosol parameters. As the apparatus matrix is composed from the set of calibration aerosol spectra vectors (Eq. 10.16), their covariation matrixes are required for calculation of errors. The covariation matrixes can be calculated on the basis of correctness estimates of the calibration aerosol parameters [Kikas and Tamm 1982]. The same can be made for the simulated data.

The method was tested in practice. The first iteration was made without considering matrix errors. The iteration process converged with 2 - 4 iterations. The test showed the notable improvement spectra estimates [Mirme 1988]. An apparatus matrix calculated from experimental data with an error account, is presented in Appendix. For the shake of readability all the elements close to the zero were corrected to the zero.

The important result of a full error account is realistic error estimates, reflecting more correctly the measuring capacity of the spectrometer with due consideration of theoretical and technical possibilities to calibrate the spectrometer. Without the full error account only the record errors would be considered, theoretical and technical mistakes would be missed. The error estimates will be higher if the conversion is not enough well posed. In short, the apparatus matrix error account removes a non-existent information, which can not be produced by the spectrometry at the given level of technical performance and our knowledge (quality of calibration), from the spectra estimates (see Sect. 3).

11. AEROSOL STUDIES BY MEANS OF THE ELECTRIC AEROSOL SPECTROMETER

EAS has been applied to aerosol studies both in laboratory and in field conditions. The comparative measurements of aerosol by EAS and other aerosol measuring instruments [Mirme *et al.* 1987, Intercomparison workshop in Vienna 1993] showed the high efficiency of EAS in the measurement of moderate resolution (the aerosol distribution width $\geq 20\%$). The fast response of EAS to the aerosol changes has been proved particularly useful in many experiments.

11.1. Observations of atmospheric aerosol

Observation of atmospheric aerosols is the primary task of the spectrometer. Special design includes a built-in heater of electric insulators which reduces the condensation of water inside spectrometer and makes the spectrometer able to work also in field conditions of high humidity.

A number of measurement campaigns have been performed, each campaign of about one to four weeks. To collect aerosol data of different climatic and environment conditions the following measurement sites were selected; Zvenigorod, near Moscow, Russia of nearly continental climate. Preila, Lithuania and Loviisa, Finland situated on the seacoast, Voore, near Tartu and Rautavaara, Finland of rural conditions. Urban aerosol studies have been made in Tartu, Tallinn (Estonia) and Kuopio (Finland) (Table. 2).

Table. 2. ATMOSPHERIC AEROSOL OBSERVATION SERIES
Air Electricity Laboratory
Tartu University, ESTONIA

Location	Date	D	I	N	M	S	O
Zvenigorod Moskow,USS R	July 86	10	5	1660		UV	
Tartu, Estonia	July 87	8	5	1695			
Voore, Es- tonia	August 87	8	5	1600	T,H, WS,WD	TR	
Tartu, Estonia	January 89	11	5	2128			
Preila, Lithu- ania	August 89	12	5	2000	T	UV	
Rautavaara, Finland	August 91	5	15	350			BC

Rautavaara, Finland	October 91	4	15	260	T,H,WS,WTR D	BC
Kuopio, Finland	November 91	10	15	920		BC
Rautavaara, Finland	December 91	7	15	570	T,H,WS,WTR D	BC
Ülenurme, Tartu, Estonia	May 92	12	15	1010	WS,WD	
Tartu, Estonia	May 92	12	15	750		NO ₂
Boistõ, Finland	June 92	16	10	1700	T,H,WS,W D	BC
Võlumäe, Rakvere, Estonia	June 92	21	10	1900	WS,WD	
Boistõ, Finland	November 92		10			BC
Tallinn, Estonia	November 92		10	1295	T,H,WS,W D	NO _x , SO ₂ , R

The following abbreviations are used in the table;

D - duration in days,

I - measurement interval in minutes,

N - total number of measurements,

M - meteorological data,

S - solar radiation data,

O - other data,

T - temperature, H - humidity,

WS - wind speed, WD - wind direction,

BC - black carbon concentration, R - air radioactivity,

UV - ultra violet radiation, TR - total radiation.

The spectrometer was used in continuous operation mode with the recording of 5 - 15 minute average aerosol spectra. Over one thousand aerosol spectra have been collected per a campaign as usual. The meteorological and other parameters are also measured as much as it was possible by the available instrumentation.

11.2. Analysis of aerosol distribution measurement data

The measurement data are analysed by the methods of time series analysis [Brillinger 1975, Kazakevitsh 1977, *etc.*], as they can be treated as time series of multicomponent random vectors. The analysis has been made assuming stationarity of the processes although the series are not

enough long and the results presented here can be considered as characterising the measurement periods. Their applicability to total atmospheric aerosol requires further studies.

The EAS observation data allow the analysis of a number of aerosol characteristics, for example, the aerosol distribution pattern, the time walks of fraction concentrations. The characteristics of time variations of fraction concentrations are extremely interesting but they have almost not been analysed yet and can be done by means of correlation analysis, the mutual variations of aerosol fractions can be studied by means of crosscorrelation functions. Correlation analysis can be a useful tool in the analysis of interchanges of aerosol and other atmospheric characteristics. Periodograms and the Fourier transformation technique may be of use, too. Finally, the atmospheric processes can be studied by modelling the variations of spectrometer measured aerosol distribution.

11.2.1. Variations of the shape of the aerosol particle size distribution

Judging by the analysis results, the number concentration distribution of continental aerosol is usually monomodal, the second mode being very rarely [Kikas 1991]. The location of the mode depends on the measurement site and the aerosol concentration with high concentrations corresponding to the mode of smaller particle sizes (Fig. 13).

The KL model of atmospheric aerosol distribution developed by Tammet [Tammet 1988] on the basis of EAS data excels by its clear physical meaning of the parameters of low mutual mathematical dependence which reduces estimation errors [Kikas, Kimmel, Mirme. 1992].

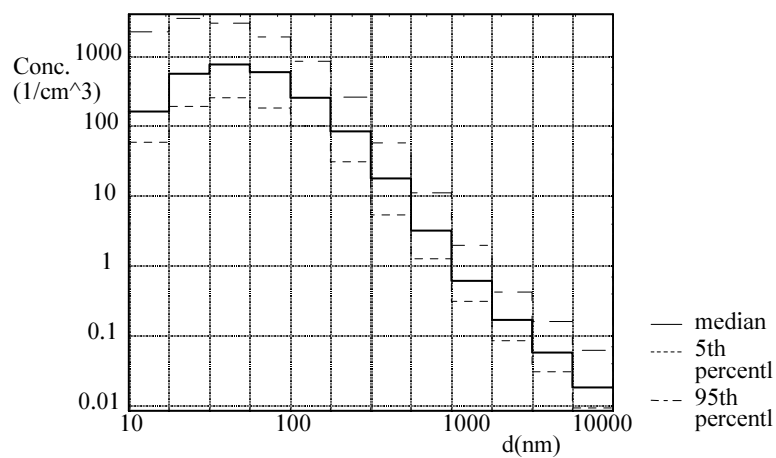

Figure 13. Continental aerosol distribution .
(Mace Head, Ireland, May-June 1994)

Marine aerosol distributions seem to have two modes although they are not fully resolved in the classical sense (Fig. 14.).

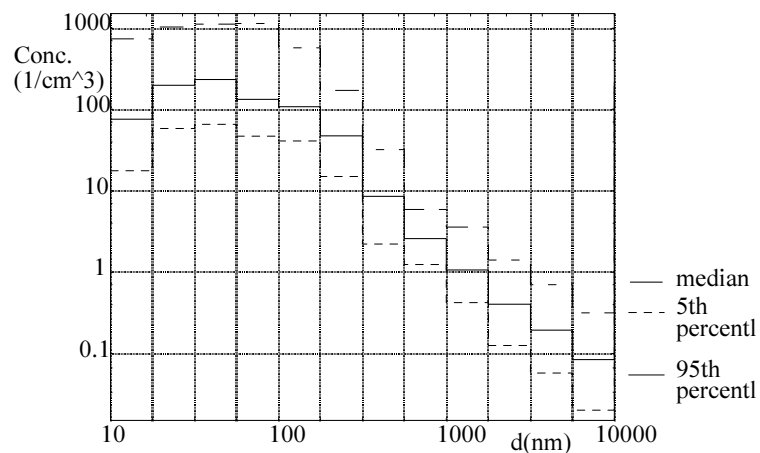

Figure 14. Marine aerosol distribution.
(Mace Head, May-June 1994)

The modal structure of marine aerosol found by EAS is in agreement with the results of Hoppel et al. (1990). Probably the reason for the separable modes is the low interaction rate between the aerosols of different fractions when new particle generation is going on in an "old" aerosol environment of low concentration. The second mode disappears at higher aerosol concentration (Fig. 14.).

11.2.2. Daily variations of atmospheric aerosol distribution

Daily variations of aerosol have a number of special features [Kikas, Mirme, Tamm 1990, 1991, Kikas 1991, Kikas, Kimmel, Mirme 1992, Kikas, Mirme, Reinart, Tamm 1992]. Higher daytime concentrations of small size aerosol particles compared to the night-time ones, is the most typical variation (Fig. 15.).

With sunrise there is a fast increase in the particle number concentration in the small size range and a moderate increase in the concentration of larger particles. After a while, the concentration of small particles drops with significant variations.

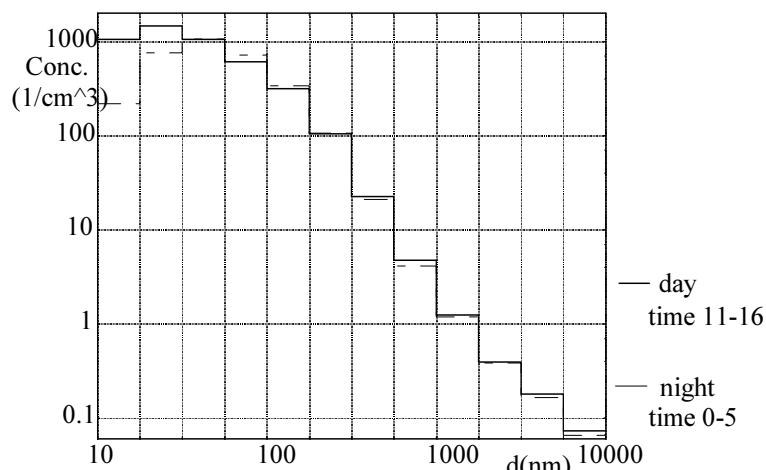

Figure 15. Typical daytime and nighttime aerosol distribution (Mace Head, May-June 1994)

The walk is typical for aerosol concentration variation when a generator of small particles starts continuously work [Lushnikov, Lyubovtseva 1988] at sunrise. The small particle number concentration drops when the concentration of middle size particles reaches the point when the small particles start to effectively coagulate to middle size particles. A conversion process of gases to particles must be going on in the daytime. The process is well demonstrated by the ratio of the concentration of the smallest aerosol fraction to the concentration of the neighbouring fraction, the high ratio indicating the presence of a small aerosol particle source. The process is also proved by the fact that the concentration increase is much higher in the urban areas of higher pollution loading

(Fig. 16) [Kikas, Mirme, Tamm 1989, Tamm, Mirme 1992]. The daily differences in the aerosol concentration walk can be explained by the direction of the wind. Strong daily variations are typical on days when the wind blows from the direction of the city and less expressed when the wind is from the countryside direction.

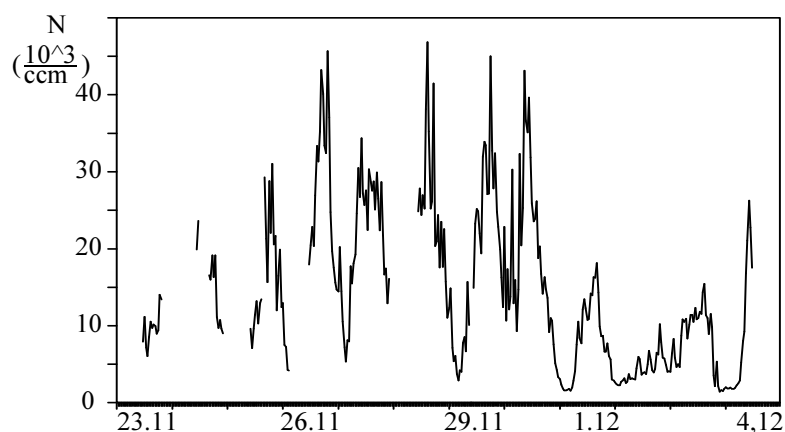

Fig.16 Aerosol number concentration in Oismae 23.11-4.12.92

Some increase of the aerosol number concentration in the afternoon is also characteristic for the aerosol and could be caused by the condensation of vapours on the particles.

11.2.3. Analysis of the autocorrelation functions of the aerosol fraction concentration

The spectrometer capable of measuring the rapidly changing aerosols without extra errors [Mirme, Tamm. 1991] is well suited for studies of fast evolution processes in the aerosol. The studies can be performed by analysing the time walks of the reaction of the aerosol spectrum to the change of environmental conditions.

The results can be reliable if the studies are made in the chambers of well-controlled environment and aerosol sources.

In the free atmosphere with a great diversity of processes, the study of the reactions to single events can hardly be effective. To gain higher reliability, statistical methods of analysis should be resorted to. The methods of correlation analysis are of that class but they are not used as they are sensible to measurement errors. The high accuracy of the EAS measurements makes it possible to use the correlation analysis methods,

the auto- and crosscorrelation function analysis in particular [Kazakevitch 1977, etc.].

As the aerosol is measured at a fixed site, the autocorrelation function of the aerosol fraction concentration showing the statistical dependence between the aerosol concentrations over the different intervals of time, characterises the time variability of the aerosol fraction concentrations at the site. Therefore the variability includes both, the actual time variability of the aerosol and the variability effected by the non-homogeneity of the aerosol masses moving over the site [Mirme, Kikas, Tamm 1988, 1988a].

Relying on the autocorrelation functions, the optimal periodicity of measurements could be established. The length of the period depends on aerosol particle size and the measurement site. The optimal measurement period of about 3 - 60 minutes is the time of tolerable change of the correlation index denoting the probability of the particle concentration change. Measurements at lower rate than the optimal may miss significant concentration changes and so the information concerning the aerosol processes.

11.2.4. An atmospheric aerosol variability model

The aerosol variability results from the variability of aerosol sources, the aerosol internal processes and the atmospheric turbulence. Analysis of the aerosol distribution data shows the dependence of the relaxation time of aerosol concentration (expressed by the width of the aerosol autocorrelation function) on the aerosol size being similar to the aerosol particle residence time [Jaenicke 1984, Hoppel *et al.* 1990] but of an order of magnitude smaller [Mirme, Kikas, Tamm 1993].

The equation used by Hoppel *et al.*, (1990) to describe the changes of the aerosol size distribution $n(r,t)$ can be written as follows:

$$\frac{\partial n}{\partial t} + \frac{n}{T_a} = Q(t) \quad , \quad (11.1)$$

where $Q(t)$ is the particle generation rate per unit volume per unit diameter interval and T_a is the total time constant of the aerosol. The autocorrelation function of the solution of this equation can be expressed by the formula:

$$R_n(\tau) = \frac{T_a}{2} \int_{-\infty}^{\infty} Q(t) e^{-\frac{\tau-t}{T_a}} dt \quad , \quad (11.2)$$

where $R_Q(t)$ is the autocorrelation function of the source function $Q(t)$. $n(t)$ and $Q(t)$ are considered centred random functions, $R_n(\tau)$ is not normalised.

It can be shown that even for an aerosol source producing short pulses of aerosol, $R_n(\tau)$ is a relaxing function with the relaxation time of the same order of magnitude as T_a . As T_a is the life time of a particle, we can see that the correlation time is nearly equal to the time of the presence of aerosol particles, i.e., the particle residence time. Consequently, the difference between the residence and the relaxation times must be the expression of a faster process than aerosol evolution, but the process must be in close relation with the evolution process as the shapes of curves τ_a and T_a are similar.

Considering the aerosol concentration variation in the atmosphere, the turbulent mixing of aerosol, when the aerosol is transported from a source to the measurement place, is the process that can effect the fast variations. The question is how they are related to the particle residence time?

Let us consider the following model of aerosol propagation: the particle sources are points of short pulse character distributed homogeneously over the ground acting randomly in time. Let us assume in accordance with the simplified meaning of the particle residence time, that the cloud of particles is detectable only during the aerosol residence time of T_a which depends on particle size.

The aerosol cloud moves from the source to the measurement site blown by the wind of velocity v . The linear dimensions of the cloud are increasing according to the turbulent diffusion theory. As the average registration time of the aerosol cloud by the measuring device is the time during which the cloud moves over the measurement site, then it can be estimated as

$$\bar{t}_c \approx \sqrt{2D_d T_a} v^{-1}, \quad (11.3)$$

where D_d is the factor of turbulent diffusion. The relaxation time τ_a of the autocorrelation function of a pulse-shaped signal is of the same order: $\tau_a \approx t_c$. Using the Richardson formula [Fuchs, 1964] of

$$D_d = C_R l^{4/3}, \quad (11.4)$$

where l is the linear dimension of the cloud and $C_R \approx 0.2 \text{ cm}^{2/3} \text{ s}^{-1}$, we obtain

$$t_c = 2\alpha_s \cdot \sqrt{\frac{R^3}{3v^2}} \quad (11.5)$$

Here α_s characterises the spatial distribution of the aerosol sources and can have values from 0 to 1, the smaller values corresponding to sources closer to the measurement site.

With $\alpha_s = 0.5$:

$$t_c \approx 0.174 T_a^{\frac{3}{2}} v^{-1} \quad (11.5a)$$

Equation (11.5a) describes the difference between the residence and relaxation times for long-living particles (100 - 300 nm of diameter) rather well (Table. 3.). Idealisation of aerosol sources may result in underestimation of the short relaxation times.

Table 3. Correlation time vs. residence time of aerosol.
 $v=10$ m/s, $\alpha_s = 0.5$ and $C_R = 2$ cm^{2/3}/s.

T	t_c
3 h.	3.6 min.
8 h.	16 min.
80 h.	8.4 h.
194 h. (8 days)	31 h.

Formula makes it possible to study also other processes in the atmosphere. For example, the characteristics of aerosol sources and the spatial distribution of sources can be estimated by analysing the aerosol fraction concentration correlation functions. The same way the peculiarities of the transport of air pollutants and other characteristics can be studied.

11.2.5. Studies of the aerosol particle evolution processes

Studies of crosscorrelation functions can provide information concerning interrelated changes of aerosol fractions.

The calculated crosscorrelation functions are usually asymmetric, the values for negative time lags differing from those for positive lags but with the maximum value of crosscorrelation at the zero lag [Mirme, Kikas, Tamm 1988, 1988a].

The shape of crosscorrelation function indicates that the aerosol fraction concentrations are formed by the processes of two kinds, the first takes place synchronously in all fractions, the other is delayed between fractions.

For sake of simplicity let us consider a linear combination of two mutually uncorrelated processes $A(t)$ and $B(t)$, the process $B(t)$ having a delay Δt between fractions. The concentration in the first fraction can be expressed as

$$N_1(t) = A(t) + B(t)$$

and in the second as

$$N_2(t) = A(t) + B(t - \Delta t).$$

Both fractions have similar autocorrelation functions:

$$R_{N1}(\tau) = R_{N2}(\tau) = R_A(\tau) + R_B(\tau). \quad (11.6)$$

The crosscorrelation function for fractions 1 and 2 can be expressed as

$$\begin{aligned} R_{N1,N2}(\tau) &= \int_{-\infty}^{\infty} N_1(t) N_2(t + \tau) dt = \\ &= \int_{-\infty}^{\infty} (A(t) + B(t)) (A(t + \tau) + B(t - \Delta t + \tau)) dt. \end{aligned} \quad (11.7)$$

As the crosscorrelation function of uncorrelated processes is equal to 0 and processes $A(t)$ and $B(t)$ are not correlated, we can estimate the crosscorrelation function as

$$R_{N1,N2}(\tau) = R_A(\tau) + R_B(\tau - \Delta t). \quad (11.8)$$

As seen, the crosscorrelation function consists of a symmetric component $R_A(\tau)$ and of a component $R_B(\tau - \Delta t)$ shifted from the zero to the lag of Δt , causing the asymmetry of the total function.

The process, that can induce a delay between fractions, can be the condensation of a vapour on aerosol particles. An increase in the fraction concentration will be reflected in an increase of the concentration in the next fraction with some time delay as it takes some time for the particles to reach the size of the next fraction. A similar effect can be produced by the coagulation of particles. The evaporation process will also produce a delay but in the opposite direction.

To estimate the value of the delay, it was assumed that wind turbulence had produced synchronous concentration variations which were fast in comparison to the aerosol evolution processes, so that crosscorrelation functions could be calculated from the smoothed in time fraction concen-

trations. The delays were estimated as lags of the peak values of these functions (Table. 4.).

Some irregularity of the lags can be accounted for by the measurement errors.

Usually the fractions of larger particles are delayed in comparison to the smaller particle fraction indicating the prevalence of aerosol particle growth processes. The studies by Kikas (1991) showed that there were also opposite lags demonstrating the particle evaporation process.

Table 4. Lags of concentration variations between aerosol fractions. (Zvenigorod, Russia; June 1986)

Fraction diameter (nm)	Lagged fraction diameter (nm)	Estimated lag (minutes)
10-18	18-32	10
18-32	32-56	90
32-56	56-100	35
56-100	100-178	50
100-178	178-316	105
178-316	316-562	210
10-18	178-316	300

In a comparative study of middle mobility air ion and aerosol concentrations [Kikas, Kolomiets, *et al.* 1990] a manifest delay of the aerosol served to prove that the ions were actually small charged particles, which grow to the sizes measured by the aerosol spectrometer.

The processes causing delay are of the same nature as those discussed in Section 11.2.4. A similar model should be applied to the studies of crosscorrelation functions.

11.2.6. Application of correlation analysis to studies of aerosol composition

Simultaneous measuring of aerosol distribution with a wide range aerosol spectrometer and other characteristics of the atmosphere with some

other measuring instrument can yield valuable information. In this way the aerosol measurements were combined with the measurements of the concentration of soot in the air (elementary (black) Carbon - BC).

No remarkable natural sources of BC are known in the atmosphere. All BC is produced by man and its presence in air can be considered as an indicator of man-made air pollution [Surakka and Ruuskanen 1993]. In the normal conditions BC can exist only in aerosol particles and a comparative analysis of aerosol particle and soot concentrations can provide information about the origin of the aerosol.

The BC concentration was measured with an Aethalometer of Magee Scientific Co. [Hansen *et al.* 1984] at Rautavaara, a rural place in eastern Finland in remote area and on Boisto island near Loviisa where there is much shipping and pollution, travelling over the Finnish Gulf [Kikas, Raunemaa, Mirme 1992, Raunemaa, Kuuspalo, *et al.* 1993].

The results show a high correlation between BC and the aerosol concentration, the correlation is linear, except for a few short periods of BC variations (Fig. 17).

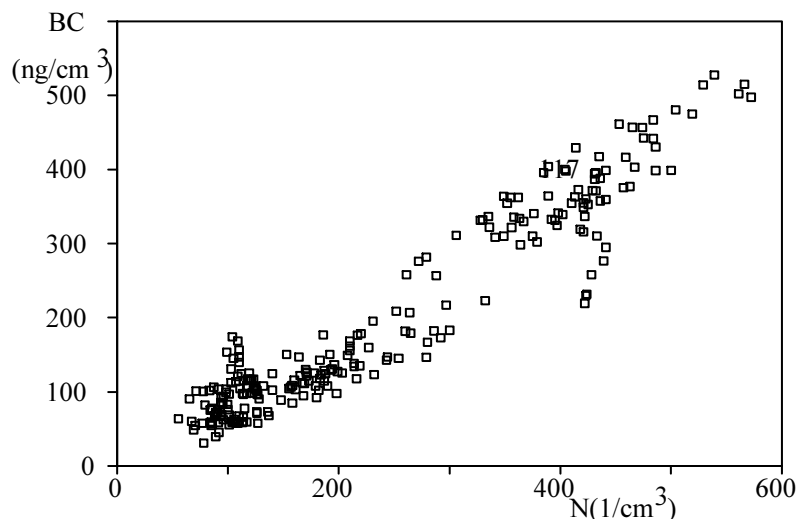

Fig.17 Black carbon concentration vs. aerosol fraction 100-180 nm Rautavaara, Oct. 1991.

Consequently a linear model of BC distribution in aerosol particles can be proposed.

Assuming that each particle contains $\beta(r)$ ng of BC and the i -th size fraction of aerosol contains $\beta_i \cdot N_i$ ng of BC, the total BC concentration can be estimated by the formula:

$$BC = \sum \beta_i \cdot N_i , \quad (11.9)$$

where N_i is the particle number concentration in the i -th fraction. As the sum of BC is taken over all n aerosol fractions, no BC is left outside the calculation.

As Equation (11.9) can be written for each measurement, we can have m equations with n unknown constants β_i :

$$\Delta BC_k = \sum \beta_i \cdot \Delta N_{i,k} , \quad k = 1 \dots m . \quad (11.10)$$

For the sake of simplicity only the deviations from the mean values are considered in this formula.

The system (Eq. 11.10) can be solved provided the total number of measurements m is not less than the number of fractions n .

As the number of measurements can be large, it is not easy to solve the system and a method of compressing the information should be used.

The system can be converted into the system of covariation equations:

$$Cov(BC * N_j) = \sum Cov(N_i * N_j) * \beta_i , \quad i, j = 1 \dots n, \quad (11.11)$$

which is the main equation of multiple regression analysis. The system of n equations with n unknown parameters β_i (11.11) can be solved as covariations of BC with aerosol fraction concentrations are known.

Data of several measurement series made at Rautavaara in 1991, were analysed. The series included about 1000 aerosol spectra and synchronously measured BC concentrations. One series covers about one week of time.

The direct solution of the system (Eq. 11.11) appeared unstable indicating that the system was ill-conditioned and to obtain usable results a regularisation of the system should be made effecting some smoothing of values of β_j .

The covariation matrix (Eq. 11.11) being of simple structure it can be supposed a correlation too high between the aerosol fractions, reflecting either the high correlation between the fractions of real aerosol or the insufficient resolving power of the spectrometer. We assumed that poor solubility was due to low spectrometer resolution, and improved the system by decreasing the values of the covariation matrix off-diagonal elements.

The calculations of $\beta(r)$ vs. particle size are shown in Figure 18. Proportionality to r^2 (particle surfaces) is presented for comparison. A good proportionality of the BC distribution in particles to particle surface can be noticed.

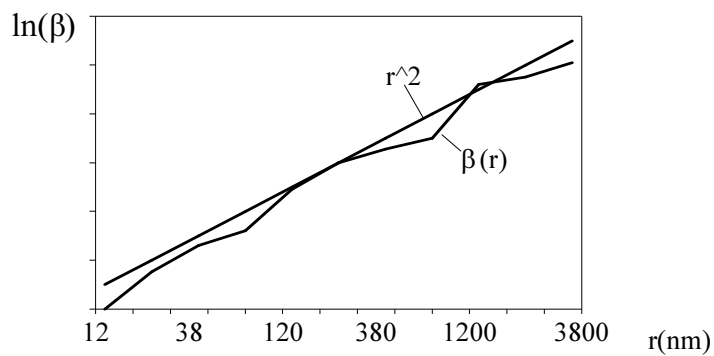

Fig. 18 BC content in aerosol particles. Rautavaara, 91.
 r^2 line - proportional to particle surface

As the regularisation changed the balance of the neighbouring aerosol fractions, the details of the distribution could be disturbed by the regularisation procedure. Thus, we will consider only the general proportionality of BC distribution to particle size. The results of the approximation of the BC distribution by power function of particle radius are presented in Table 5 in the form of the power of radius of approximation formula.

Table 5. Dependence of the BC content in aerosol particles on the particle size.

Period	Proportionality (power of radius)
August 91	1.7
October 91	1.8
December 91	2.03

The effect of the regularisation was checked by varying the regularisation rate. Change of the regularisation rate in the wide range reflects in the change of the power of (r) less than $\pm 15\%$.

The result can be proved by comparing the values of BC correlation with the different types of the aerosol particle concentrations (Table 6) as the particle number (sum of particles per cm^3), diameter (sum of diameters of particles per cm^3), surface (sum of surfaces of particles per cm^3) and volume (sum of particle volumes per cm^3) concentrations, have different proportionality with the particle size.

Table. 6 Correlation of Black Carbon mass concentration with different types of aerosol concentrations.

Period	Total number	Total diam.	Total surface	Total volume
December 91	.58	.70	.80	.69
June 92	.62	.68	.66	.60

It can be supposed that the type of aerosol concentration of the highest correlation with BC indicates the proportionality of BC distribution in particles. For example, in June 92 the distribution of the BC seems to be most proportional to the diameter of the particles (first power of radius).

Some dependence of the proportionality factor on the time and the site of the measurement can be noticed. The correlation between the BC mass concentration and the aerosol surface concentration is of the highest in December 91 (Table 6). In June 92 the correlation with the aerosol diameter concentration (sum of $2*r_p$) is of the highest value, indicating that there was more soot in small particles in June 92.

The BC content in particles seems to depend on the season of the year, but further studies are needed.

Even if the proportionality of BC to the particle surfaces is an effect of the Aethalometer measurement principle, the dependence of BC distribution on the measurement site and the season of the year gives information, for example, on human polluting activity as measurements in June 92 were made in the most polluted environment.

11.3. Studies of environment pollution

Sources of anthropogenic pollution are highly variable in time and in space as a rule. Usually long-term average characteristics are measured for reasonable results. The electric aerosol spectrometer allows to follow

fast changes and provides extra information concerning fine structure of pollution process.

The spectrometer can measure pollution directly due to its capacity to work in the conditions of heavy pollution [Kunda cement factory].

The sources polluting the atmosphere have been studied indirectly by analysing the dependence of aerosol concentrations and the aerosol distribution shape, on wind direction [Kikas, Mirme, Tamm 1991a, Kikas 1992], which gives also the information concerning the pollution transport.

The power of the aerosol sources and filters has been measured directly for each fraction by measuring aerosol concentrations with and without a filter [Raunemaa *et al.* (1992)].

Additionally, the EAS can be used for estimating the power of aerosol sources and the cleaning power of aerosol filters when it is not possible to measure directly the filter particle removal capacity or the source particle generation capacity. As the EAS can measure fast varying aerosols, the filter and the source efficiencies can be estimated by measuring the rate of aerosol concentration variation in fractions. A high accuracy of the measurements can be achieved when the aerosol generator or the filter is switched periodically on and off. Provided there is a small total change in the aerosol distribution and the other parameters of the environment are stable, we can assume that the internal processes of the aerosol do not change and the difference between the rates of the aerosol i -th fraction concentration change, in the filter on and off stages. The change in the concentration can be considered to be the effect of the filter switching only [Mirme, Tamm. 1991a] (Eq. 11.12).

$$\frac{dN_i}{dt} \Big|_{on} - \frac{dN_i}{dt} \Big|_{off} = \frac{P_i}{V_c}, \quad (11.12)$$

where V_c is the volume of the chamber, P_i is the power of the device (the number of particles of the i -th fraction generated or removed by the device per unit of time) in the switched-on stage. For a filter its power can be defined as

$$P_i = -N_i \eta_i, \quad (11.13)$$

where η_i is the volume of the air cleaned from particles of the i -th fraction by the filter in one unit of time, η_i can depend on the particle size. For an aerosol source, P_i is the number of particles generated by the source per unit of time.

An electric filter based on electric wind was tested in this way. As electric wind is sensitive to the construction elements near the filter, the special testing equipment could not be used and the measurements were made in the natural conditions of a working room. The evaluated filtration power is presented in Figure 19. The reduction of the filtering power for small particles at high voltage can be accounted for by the self-generation of aerosol particles by corona discharge in the filter.

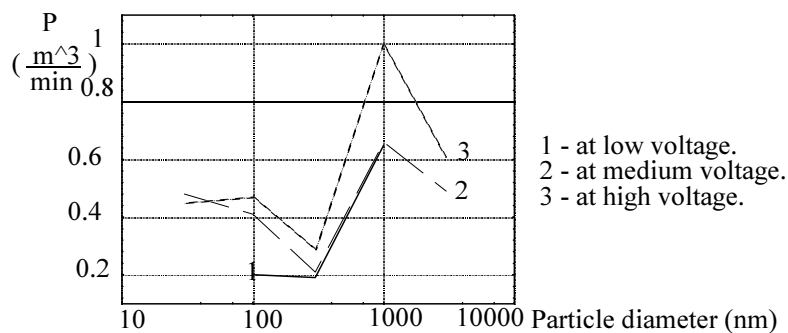

Figure 19. Filtering power of electric aerosol filter.

11.4. Studies of aerosol generation

Aerosol particle generation and formation processes are of fundamental interest in aerosol physics today. These processes start with groups of few molecules. Groups of molecules in the air can be considered to be particles if they are able to grow gradually, without decomposition. The thresholds for size of the groups lie in the range of nanometers.

To study the nanometer-size particles the electric aerosol spectrometer measurement range can be extended from 10 nm to the size, close to the size of the ions of the spectrometer charger. The size of the charger ions can be considered as the principal particle size limit of the electric method.

The regularities of aerosol particles formation in corona discharge were studied [Tamm, Mirme; Kikas 1988, 1992] in this way. The spectrometer was used to measure the particles in the range of 1.8 to 18 nm of diameter. The sizes were overestimated about 0.5 nm as the correction factor proposed by Tammet (1992) was not used. As the resolution of electric spectrometry is high in that size range (Fig. 6) the density of the fractions was doubled so that eight aerosol fractions per decade of sizes were measured.

The aerosol was generated by a point-to-cylinder corona discharge supplied with a cylindrical relaxation chamber. The aerosol particle distribution was measured at different values of corona current, air flux and length of relaxation chamber. The following results were obtained.

Corona discharge always seemed to produce aerosol particles, but of different size. The particles became smaller with high air flux or low corona current. The size distribution was narrow (relative width <25%) which is typical of a condensation aerosol.

The complicated dependence of particle generation on the parameters of the experiment could be simplified by recombining the experiment parameters. The corona discharge current I_+ , I_- and the particle relaxation time T_R were taken as input parameters and the particle production in the number of particles per one second P_p , and the particle mean radius r were taken as output parameters. In these terms the general regularities of aerosol formation in corona discharge of negative corona were described as

$$P_p \approx I_- \quad , \quad r \approx T_c \sqrt{I_-} \quad (11.14)$$

and of positive corona as

$$P_p \approx I_+^2 \quad , \quad r \approx T_c \cdot I_+ \quad (11.15)$$

The relationships can be well explained by assuming that the corona discharge produces things of two kinds; nuclei P_N and vapour of some substance P_v . The production depends on the value of corona current as:

$$P_N, P_v \approx I_- \quad (11.16)$$

for negative corona and as

$$P_N, P_v \approx I_+^2 \quad (11.17)$$

for positive corona.

The proportionality of negative corona was proved naturally later by finding that the negative corona current consisted of pulses of constant shape, an increase of current resulted only in a proportional increase of frequency of pulses.

The origin of vapour could not be studied in detail because of the sufficiently sensitive method of study. In fact, the EAS can detect the nanometer size particles of the mass concentration of about 10^{-12} g/m³ and even a chemical reaction triggered by corona ions in some impurity of the air can generate aerosol particle concentration detectable by the EAS.

The generation of particles in corona discharge was discovered by Nolan and O'Toole (1959) but they had no possibility to measure the size distribution of particles. The generation of particles was also found to take place in inert gas environment [Zagainov *et al.* 1987].

The monodispersity and stability of the corona discharge aerosol recommend it as a test aerosol in calibration [Mirme, Kikas, Tamm 1991].

The generation of aerosol by UV radiation has also been studied [Priiman and Kikas 1985]. An interesting effect of aerosol concentration oscillations was discovered in the experiments carried out in non-hermetic chamber surrounded by a larger room [Kaasik 1990]. The oscillations could have been caused by the vapour exchange between the chamber and the room.

12. CONCLUSIONS

In this thesis the principles of electric aerosol spectrometry for atmospheric aerosol studies are investigated. A wide-range multichannel Electric Aerosol Spectrometer (EAS) has been designed for the purpose. The results of atmospheric aerosol studies and the results of research on certain aspects of aerosol generation and filtration processes are presented.

The basic task of atmospheric aerosol research today is to study aerosol distributions, especially the particle size distribution in a wide range of aerosol parameters. A combination of electric methods for aerosol particle size characterisation can provide the necessary information for practically full range of particle sizes.

The EAS has been designed to meet the quality requirements for spectrometers expressed by the spectrometer resolution ability and sensitivity having been adapted to the needs of atmospheric aerosol studies, which provides the optimal selection of spectrometer construction parameters.

The aerosol particle focusing effect improves the EAS resolution in the range of submicron particles. The extra aerosol flux in the charger preserves the resolution capacity and allows sufficient sensitivity at the margins of the measurement range. The parallel use diffusion and field charging allow to widen the regular measurement range of electric spectrometers (10 nm to 500 nm) to the size range essential for atmospheric aerosol studies (from 10 nm to 10 μm) and even further down to 2 nm.

The principle of simultaneous parallel measurement based on the aerosol particle classifying into a number of channels, the collecting and simultaneous measuring of the signals in each channel makes it possible to use all the aerosol sample and measure the size distribution in few seconds. For a twelve-fractions distribution it makes for a twelve-fold difference in measurement time, comparing to a nonparallel instrument measuring one fraction at the time. The actual EAS superiority in information productivity is even higher as its results are free of errors due to the aerosol concentration variations in sequential instruments. The EAS can present the correct average aerosol distribution of the measurement period even for a highly varying aerosol.

The proposed method of measurement data processing facilitates the fast measurement by correcting the instrumental inertia and provides the maximum signal-to-noise ratio for low aerosol concentrations. It also provides for high flexibility of the measurement process.

Aerosol spectrometry being of high complexity, the measurements can be of value only if the actual characteristics of the spectrometer and the known *a priori*, information of the aerosol, are properly taken into account. The data processing methods based on the well-balanced use of theoretical knowledge and empirical data also due consideration of calibration errors, discussed in the paper provide for the maximal total quality of the spectrometry.

As a result, the EAS measurement range is 10 nm to 10 μm of particle diameter. The sensitivity in full size range is sufficient for measuring normal aerosol concentrations ($N \sim 3000 \text{ cm}^{-3}$). Only in very clean conditions ($N \sim (100-300) \text{ cm}^{-3}$) the effective measurement range is limited for highly-dispersed and submicron particles. The performance of EAS allows to extend the measurement range to the physical limit of the unipolar charging method (about 1.5 nm). The EAS can work in a wide range of meteorological conditions including 100% humidity, during long periods lasting several months without any maintenance. As the dynamic range of the concentration reaches 10^4 times, EAS can measure correctly even significant and great fast aerosol fluctuations in heavily polluted environment.

The EAS system has been used in a number of atmospheric aerosol measurement campaigns. Tens of thousands of spectra of atmospheric aerosol have been measured.

The main regularities of atmospheric aerosol distribution time walk are clearly reflected in the measurements. Some new regularities in the variations of aerosol of different location (rural, urban, remote area, seaside, continental) have been pointed out which contributes to the better understanding of aerosol pollution.

The stability of atmospheric aerosol, estimated as the relaxation times of the aerosol fraction concentrations facilitates the planning of environment monitoring systems.

An atmospheric aerosol variability model developed on the basis of the correlation analysis of the aerosol data, accounts for the relation between the aerosol relaxation time and the particle residence time. Peculiarities of aerosol transport, also spatial distribution and character of environment polluting sources can be studied with the help of the model, thus bridging the gap between the atmospheric aerosol theory and practice.

A method of estimating the aerosol particle transformation rate has been developed. The preliminary estimation of the rate of condensation-

coagulation processes in natural conditions has been made. The particle evaporation process has been observed experimentally.

The distribution of soot (Black Carbon) in aerosol particles at different locations and in different seasons of the year has been estimated by the combined statistical analysis of the EAS data and the data obtained with an Aethalometer. BC happens to be distributed in particles more or less proportionally to the second power of the particle radius, i.e., proportionally to the particle surfaces, the proportionality coefficient depending slightly on the location and the season of the year. The method demonstrates the accuracy of EAS measurements. The method can be effectively used to estimate the environment characteristics.

The method of estimation of the aerosol pollution source and aerosol filter efficiencies in natural conditions allows to measure the characteristics of the devices without upsetting their normal operation. The efficiency of an electric wind based electric filter is measured.

Aerosol generation in corona discharge has been studied. The corona aerosol is monodispersed, with the particle size in the range of a few nanometers. The dependence of the particle size distribution on the experiment parameters shows that the nuclei and some vapour are generated separately. The particles are formed later by condensation.

Most of the results presented are preliminary. Extended studies based on the methods described and the studies of the methods themselves as well as the developing of new methods are to be continued.

REFERENCES

- Berglund, R.N. and Liu, B.Y.H. (1973) Generation of monodisperse aerosol standards. *Environ. Sci. and Technology*, vol.7, p.147-153.
- Bernotas, T.P., Kikas, Ü.E. and Mirme, A.A. (1979) A condensation type generator of submicron aerosols. *Acta et Comm. Univ. Tartuensis*. No.479, p.128-131 (in Russian).
- Binek, B. (1961) Szintillationspektralanalysator für Aerosolteilchen. *Zentr.-blatt Aeros.*, vol.9, No.6, p.488.
- Biswas, P., Jones, C.L. and Flagan, R.C. (1987) Distortion of size distributions by condensation and evaporation in aerosol instruments. *Aerosol Sci. and Technology*, vol.7, p.231-246.
- Brillinger, D.R. (1975) *Time Series. Data Analysis and Theory*. Holt, Rinehart and Winston, inc.
- Brock, J.R. (1970) Aerosol charging: the role of the image force. *J. Appl. Phys.*, vol.41, p.843.
- Crump, J.G. and Seinfeld, J.H. (1982) A new algorithm for inversion of aerosol size distribution data. *Aerosol Sci. and Technology*, vol.1, No.1, p.15-34.
- Davies R. (1974) Rapid response instrumentation for particle size analysis, part 2, *American Laboratory*, January 1974, p.73.
- Emets, E.P., Kascheev, V.A. and Poluektov, P.P. (1993) Statistics of aerosol electric charging. *J. Aerosol Sci.*, vol.24., No.7., p.867-877.
- Fischer, M.M. and Tamm, E.I. (1974) Trajectory and aspiration methods of aerosol distribution measurement. In *Fizicheskie Aspekty Zagryazneniya Atmosfery. Tez. Dokl. Mezhdunar. Konf.*, Vilnyus, p.144-145 (in Russian).
- Friedlander, S.K. (1970) The characterization of aerosols distributed with respect to size and chemical composition, part 1. *J. Aerosol Sci.*, vol.1, p.295
- Friedlander, S.K. (1971) The characterization of aerosols distributed with respect to size and chemical composition, part 2. Classification and design of aerosol measuring devices. *J. Aerosol Sci.*, vol.2, p.331-340.

- Friedlander, S.K. (1971) The characterization of aerosols distributed with respect to size and chemical composition, part 2. Classification and design of aerosol measuring devices. *J. Aerosol Sci.*, vol.2, p.331-340.
- Fuchs, N.A. (1947) On the magnitude of electrical charges carried by the particles of atmospheric aerocolloids. *Izv. AN SSSR, ser. geogr. i geofiz.*, vol.11, No.4, p.341-348 (in Russian).
- Fuchs N.A. (1964) *The Mechanics of Aerosols*, Pergamon Press, Oxford.
- Fuchs, N.A. (1986) Methods for determining aerosol concentration. *Aerosol Sci. and Technology*, vol.5, No.2, p.123-143.
- Hansen, A.D.A., Rosen, H. and Novakov, T. (1984) The aethalometer - an instrument for real-time measurement of optical absorption by aerosol particles. *Sci. Total Environ.*, vol.36, p.191-196.
- Heintzenberg, J. and Covert, D.S. (1990) On the distribution of physical and chemical particle properties in the atmospheric aerosol. *J. Atmospheric Chemistry*, vol.10, p.383-397.
- Hewitt, G.W. (1957) The charging of small particles for electrostatic precipitation. *Trans. Am. Inst. Electr.*, vol.76, No.31, p.300-306.
- Hoppel, W.A. (1978) Determination of the aerosol size distribution from the mobility distribution of the charged fraction of the aerosol. *J. Aerosol Sci.*, vol.9, p.41-54.
- Hoppel, W.A., Fitzgerald, J.W., Frick, G.M., Larson, R.E. and Mack, E.J. (1990) *J. Geophysical Res.*, vol.95, No.D4., p.3659-3686.
- Jaenicke R. (1976) Methods for determination of aerosol properties. In *Fine Particles: Aerosol Generation, Measurement, Sampling and Analysis* (edited by Liu, B.Y.H.), Academic Press, New York, p.467.
- Jaenicke R. (1984) Our knowledge about the atmospheric aerosol. 11th Int. Conference On Atmospheric Aerosols, Condensation and Ice Nuclei. Budapest, 1984, vol.1., p.99-107.
- Jaenicke R. (1990) Problems of global distribution of aerosol. *Uspekhi Khimii*, Academy of sciences USSR, vol.59, p.1654-1675 (in Russian).
- Jakobson, A., Salm, J. and Tammet, H. (1975) Some results of testing the multichannel automatic spectrometer of air ions. *Acta et Comm. Univ. Tartuensis*, No.348, p.16-23 (in Russian).

- Jantunen, M.J. and Reist, P.C. (1983) General field charging theory for aerosol particle charging and neutralizing in unipolar and bipolar ion fields. *J. Aerosol Sci.*, vol.14, p.127.
- John, W., Wall, S.M., Ondo, J.L. and Winklmayr, W. (1990) Modes in the size distribution of atmospheric inorganic aerosol. *Atmospheric Environment*, vol.24A, No.9, p.2349-2359.
- Junge, Chr. (1955) The size distribution and aging of natural aerosols as determined from electrical and optical data in the atmosphere, *J. Meteorol.*, vol.12, No.1, p.13-25.
- Kaasik, M. (1990) Diploma thesis.
- Kascheev, V.A., Emets, P.P. and Poluektov, P.P. (1991) Determination of aerosol particle sizes and charges with DMA and laser size analyzer. In *European Aerosol Conference. Karlsruhe. Abstracts of Papers*, p.318.
- Kazakevich, D.I. (1977) *Principles of Random Functions Theory and Its Use In Meteorology*. Gidrometeoizdat, Leningrad (in Russian).
- Keskinen, J., Pietarinen, K. and Lehtimäki, M. (1992) Electrical low pressure impactor. *J. Aerosol Sci.*, vol.23, No.4, p.353-360.
- Keskinen J. (1992) *Experimental Study of Real-Time Aerosol Measurement Techniques*, Tampere University of Technology, Tampere.
- Kikas, Ü.E., Susi, R.E. and Tamm, E.I. (1982) On the theory of electrostatic separation of aerosols. *Acta et Comm. Univ. Tartuensis*, No.631, p.76-84 (in Russian).
- Kikas, Ü.E. and Tamm, E.I. (1982) On the quality of electrically separated calibration aerosols. In *Tez. Dokl. IV Vses. Konf. Po Aerozolyam*, Erevan, p.50-51 (in Russian).
- Kikas, Ü.E., Mirme, A.A., Peil, I.A. and Tamm, E.I. (1984) About electrical separation of aerosol particles. *Metody i Pribory Kontrolya Parametrov Biosfery. Mezhvuz. Sb. Leningrad*, No.171, p.36-42 (in Russian).
- Kikas, Ü.E., Mirme, A.A., Peil, I.A., Tamm, E.I. and Tammet, H.F. (1985) Experimental calibration of an electrical aerosol spectrometer by the method of test aerosols. *Acta et Comm. Univ. Tartuensis*, No.707, p.54-71 (in Russian).

- Kikas, Ü. (1987) On the quality of electrically separated calibration aerosols. *Acta et Comm. Univ. Tartuensis*, No.755, p.106-112 (in Russian).
- Kikas, Ü., Mirme, A., Kruuv, H. and Tamm, E. (1988) A generator of monodisperse aerosol. Patent USSR, B05B17/04, No.1388103, Prior. 12.09.86., Bull. No.14 (in Russian).
- Kikas, Ü., Mirme, A. and Tamm, E. (1989) Measurement of urban aerosol. In *Tez. Dokl. XV Vses. Konf. Aktualnye Voprosy Fiziki Aerodispersnykh Sistem*. Odessa, vol.2, p.114 (in Russian).
- Kikas, Ü., Mirme, A. and Tamm, E. (1990) Size distribution dynamics of rural and urban aerosols. *Acta et Comm. Univ. Tartuensis*, No.880, p.84-93.
- Kikas, Ü., Kolomiets, S.M., Kornienko, V.I., Mirme, A., Salm, J., Sergeev, I.Ya. and Tammet, H. (1990) The complex measurement of the characteristics of aerosol and air ions in the ground layer of the atmosphere. *Tr. In-ta Eksperim. Meteorologii*, No.51(142), p.109-117 (in Russian).
- Kikas, Ü., Mirme, A. and Tamm, E. (1991) Maalähedase aerosooli allikatest ja levikust (Sources and transfer of near-ground atmospheric aerosol). In *Kaasaegse ökoloogia probleemid. Eesti V ökoloogiakonverentsi teesid*. Tartu, p.74-76 (in Estonian).
- Kikas, Ü. (1991) Processes transforming near-ground atmospheric aerosol spectra. *J. Aerosol Sci.*, vol.22, suppl.1, p.641-644.
- Kikas, Ü., Mirme, A. and Tamm, E. (1991) Variability of near-ground atmospheric aerosol. *J. Aerosol Sci.*, vol.22, suppl.1, p.637-640.
- Kikas, Ü. (1992) The identification of particle sources by aerosol spectra measurements. *Acta et Comm. Univ. Tartuensis*, No.950, p.73-79.
- Kikas, Ü., Kimmel, V. and Mirme, A. (1992) Spectra of near-ground atmospheric aerosols. *Acta et Comm. Univ. Tartuensis*, No.947, p.125-135.
- Kikas, Ü., Mirme, A., Reinart, A. and Tamm, E. (1992) Atmospheric aerosol as an indicator of human polluting activity. *J. Aerosol Sci.*, Vol.23, Suppl.1, p.1023-1026.
- Kikas, Ü., Raunemaa, T. and Mirme, A. (1992) Comparison of black carbon and 0.010-10.0 μm aerosol in the city of Kuopio and remote area Rautavaara in Finland. *European Aerosol Conf. Single page abstracts*. Oxford, p.297.

- Kirsh, A.A. and Zagnitko, A.V. (1980) On diffusion charging of submicron aerosols with unipolar ions. *Kolloidnyi Zhurnal*, vol.52., No.1, p.131-135 (in Russian).
- Knutson, E.O. and Whitby, K.T. (1975) Aerosol classification by electric mobility: apparatus, theory, and applications. *J. Aerosol Sci.*, vol.6, p.443-451.
- Kojima, Hiroshi (1978) Measurements of equilibrium charge distribution on aerosols in bipolar ionic atmosphere. *Atmospheric Environment*, vol.12, p.2363-2368.
- Koltsov, B.Yu. (1979) Method for aerosol mass concentration measurement. In *Metody i Pribory Kontrolya Parametrov Okruzhayushchei Sredy*. Leningradskii Institut Aviatsionnogo Priborostroeniya. Leningrad. p.31-36 (in Russian).
- Kurochkin, S.S and Murin, I.D. (1975) *Modern Electronics for Nuclear Research*, vol.1. Izmeritelnye Sistemy i Ustroistva, Atomizdat (in Russian).
- Liu, B.Y.H., Whitby, K.T., and Yu, H.H.S. (1967) On the theory of charging of aerosol particles by unipolar ions in the absence of an applied electric field. *J. Colloid Interface Sci.*, vol.23, p.367-378.
- Liu, B.Y.H. and Pui, D.Y.H. (1974) Electrical neutralization of aerosols. *J. Aerosol Sci.*, vol.5, p.465-472.
- Liu, B.Y.H. and Pui, D.Y.H. (1974a) A submicron aerosol standard and the primary, absolute calibration of the condensation nuclei counter. *J. Colloid Interface Sci.*, vol.47, No.1, p.155-171.
- Liu, B.Y.H., Pui, D.Y.H. and Kapadia, A. (1976) Electrical aerosol analyser: history, principle and data reduction. *Particle Technology Laboratory Publ.*, No.303, p.1-41.
- Liu, B.Y.H. and Pui, D.Y.H. (1977) On unipolar diffusion charging of aerosols in the continuum regime. *J. Colloid Interface Sci.*, vol.58, No.1, p.142-149.
- Liu, B.Y.H. and Kapadia, A. (1978) Combined field and diffusion charging of aerosol particles in the continuum regime. *J. Aerosol Sci.*, vol.9, p.227-242.
- Liu, C.S., Davisson, S. and Gentry, J.W. (1982) Bipolar charge equilibrium for spherical aerosols (minimum flux hypothesis). *The Sci. Total Environ.*, vol.23, No.4, p.337-342.

- Liu, C.S. and Gentry, J.W. (1982) Charge distribution of ultrafine aerosols undergoing bipolar charging. *J. Aerosol Sci.*, vol.13, No.2, p.127-138.
- Lushnikov, A.A. and Lyubovtseva, Yu.S. (1988) Atmospheric aerosols - the subject of physico-chemical study. *Lecture Notes in Physics*, No.309, p.138-157.
- Matisen, R. (1988) The methods for computing reliability of air electricity measurement devices. *Acta et Comm. Univ. Tartuensis*, No.809, p.103-110.
- Matisen, R., Miller, F., Tammet, H., and Salm, J. (1992) Air ion counters and spectrometers designed in Tartu University. *Acta et Comm. Univ. Tartuensis*, No.947, p.60-67.
- Miller, F. (1981) On the construction of electrometers of direct amplification for multichannel spectrometers of air ions. *Acta et Comm. Univ. Tartuensis*, No.588, p.124-132 (in Russian).
- Mirme, A.A., Salm, J.J., Tamm, E.I. and Tammet, H.F. (1979) Granulometer of submicron aerosol. *Metody i Pribory Kontrolya Parametrov Okruzhayushchei Sredy. Mezhvuz. Sb. Leningrad*, No.1(136), p.64-67 (in Russian).
- Mirme, A.A., Tamm, E.I. and Tammet, H.F. (1981) An aerosol electric granulometer with a wide measuring range. *Acta et Comm. Univ. Tartuensis*, No.588, p.84-92 (in Russian).
- Mirme, A.A. (1982) An electric granulometer combined with a mini-computer of the type "Elektronics DZ-28". *Acta et Comm. Univ. Tartuensis*, No.631, p.111-118 (in Russian).
- Mirme, A.A. (1983) On the optimization of the measurement process of an aerosol electric spectrometer. *Acta et Comm. Univ. Tartuensis*, No.648, p.59-72 (in Russian).
- Mirme, A.A. and Peil, I.A. (1983) A multichannel electric aerosol spectrometer with a changeable measuring range and resolving power. *Acta et Comm. Univ. Tartuensis*, No.648, p.73-79 (in Russian).
- Mirme, A.A., Tamm, E.I. and Tammet, H.F. (1983) A method for determination size spectral composition of aerosols. Patent USSR, G01N15/02, No.1035477, Prior. 08.01.82., Bull. No.30 (in Russian).
- Mirme, A.A. (1984) An experimental study of the noise of an electric aerosol spectrometer. *Acta et Comm. Univ. Tartuensis*, No.669, p.79-84 (in Russian).

- Mirme, A.A., Tamm, E.I., Peil, I.A. and Valkovoi, M.F. (1984) An aerosol granulometer. Patent USSR, G01N15/02, No.1092383, Prior. 01.04.82., Bull. No.18 (in Russian).
- Mirme, A.A., Tammet, H.F., Bernotas, T.P. and Tamm, E.I. (1984a) Signal control and processing in electric aerosol spectrometer. *Metody i Pribory Kontrolya Parametrov Biosfery. Mezhvuz. Sb.*, Leningrad, No.171, p.43-45 (in Russian).
- Mirme, A., Noppel, M., Peil, I., Salm, J., Tamm, E. and Tammet, H. (1984b) Multi-channel electric aerosol spectrometer. In *Eleventh Int. Conf. On Atmospheric Aerosols, Condensation and Ice Nuclei*. Budapest, vol.2, p.155-159.
- Mirme, A. (1987) About the calibration of the electrical aerosol spectrometer. *Acta et Comm. Univ. Tartuensis*, No.755, p.71-79 (in Russian).
- Mirme, A., Reinart, A., Kikas, Ü., Tamm, E., Dubrovin, M.A., Bernotas, T. and Peil, I. (1987) Measurement of calibration aerosol spectra. Comparison of the TSI aerosol analyzer with the aerosol spectrometer of Tartu State University. *Acta et Comm. Univ. Tartuensis*, No.755, p.80-88 (in Russian).
- Mirme, A. (1988) Calibration errors accounting for aerosol spectrometer. *Acta et Comm. Univ. Tartuensis*, No.809, p.111-117 (in Russian).
- Mirme, A., Kikas, Ü. and Tamm, E. (1988) The dynamics of the near-ground atmospheric aerosol spectra. *Acta et Comm. Univ. Tartuensis*, No.824, p.109-122 (in Russian).
- Mirme, A., Kikas, Ü. and Tamm, E. (1988a) Time-size structure of atmospheric aerosol. *Lecture Notes in Physics*, No.309, p.52-55.
- Mirme, A., Kikas, Ü. and Tamm, E. (1991) A generator of monodisperse aerosol. Patent USSR, B05B17/04, No.1634330, Prior. 29.07.88., Bull. No.10 (in Russian).
- Mirme, A. and Tamm, E. (1991) Comparison of sequential and parallel measurement principles in aerosol spectrometry. *J. Aerosol Sci.*, Vol.22, Suppl.1, p.331-334.
- Mirme, A. and Tamm, E. (1991a) Measurement of the rate of aerosol particles formation and decay processes. *Report Series in Aerosol Science*. Helsinki, No.19, p.119-123.

- Mirme, A., Kikas, Ü. and Tamm, E. (1993) Correlation time of near-ground atmospheric aerosol. *J. Aerosol Sci.*, Vol.24, Suppl.1, p.S3-S4.
- Mirme, A. and Tamm, E.(1993) Electric aerosol spectrometer. Calibration and error account. *J. Aerosol Sci.*, Vol.24, Suppl.1, p.S211-S212.
- Mirzabekyan, G.Z. (1966) Charging of conductive spherical particles with radii comparable to the distance of free path of ions in air. *Tekhnicheskaya Fizika*, vol.36, No.7, p.1259-1268 (in Russian).
- Mirzabekyan, G.Z. (1969) Aerosol charging in the field of corona discharge. In *Strong Electric Fields in Technological Processes* (Edited by Popkov, V.I.). Energy Press, p.28-30.
- Nicholson, K.W. (1988) A review of particle resuspension. *Atmospheric Environment*, vol.22, No.12, p.2639-2651.
- Noppel, M. (1978) Maatrikselementide vigade arvestamisest statistilise regulariseerimise meetodite rakendamisel (Account of errors in matrix elements by statistical regularization). In *TRÜ Füüsikaosakonna Üliõpilaste Teaduslikke Töid*. Tartu, p.30-43 (in Estonian).
- Noppel, M.G. (1982) Account of errors in the elements of apparatus matrix at statistical estimation of spectrum in spectrometry. In *Füüsika: Teadus ja Tootmine. Füüsikaosakonna Juubelikonverentsi Ettekannete Teesid*. Tartu, p.54 (in Russian).
- Noppel, M.G. (1982a) About charge distribution on aerosol particles charged with small air ions. *Acta et Comm. Univ. Tartuensis*, No.631, p.85-93 (in Russian).
- Noppel, M.G. (1983) About charge distribution on aerosol particles charged with unipolar small air ions. *Acta et Comm. Univ. Tartuensis*, No.648, p.32-40 (in Russian).
- Noppel, M.G. (1985) Charge distribution of aerosol particles charged in a strong electric field. *Acta et Comm. Univ. Tartuensis*, No.707, p.79-83 (in Russian).
- Noppel, M.G. (1985a) Algorithm for rapid approximate calculation of charge distribution of conductive aerosol particles charged in a strong electric field. *Acta et Comm. Univ. Tartuensis*, No.707, p.84-93 (in Russian).

- Noppel, M.G. and Peil, I.A. (1986) Electrical charges on fine aerosol particles. In III Vses. Simpoz. Po Atmosfernomu Elektrichestvu. Tez. Dokl. Tartu, p.56 (in Russian).
- Noppel, M. and Tammet, H. (1987) Method and algorithm for calculation of the apparatus matrix for electrical aerosol spectrometer. Acta et Comm. Univ. Tartuensis, No.755, p.62-70 (in Russian).
- Noppel, M. (1989) Theory and methods for determination of apparatus matrix of the electrical aerosol analyzer. Abstract of a thesis. Leningrad. Glavnaya Geofizicheskaya Observatoriya (in Russian).
- Noppel, M. (1990) Analysis of measurement methods of aerosol size spectrum with electrical analyzer TSI-3030. Acta et Comm. Univ. Tartuensis, No.880, p.67-83.
- Paatero, P. (1990) The Extreme Value Estimation Deconvolution Method With Applications In Aerosol Research. Univ. of Helsinki, Report series in Physics. HU-P-250.
- Parts, T. (1988) On the nature of the small positive air ions. Acta et Comm. Univ. Tartuensis, No.824, p.24-30.
- Parts, T. (1990) On the nature of negative small air ions. Acta et Comm. Univ. Tartuensis, No.880, p.52-60.
- Pauthenier, M. and Moreau-Hanot, M. (1932) La charge des particules spheriques dans un champ ionise. J. de Phys. et le Radium, vol.3, No.12, p.590-613.
- Podolskii, A.A., Pustoshkin, B.N., Rumyantsev, V.V. and Turubarov, V.I. (1972). Method for measurement the concentration of dispersed phase of aerosol. Patent USSR No.340942. Byulleten izobretenii, No.18 (in Russian).
- Podolskii, A.A. (1976) Cylindric inductional sensors for charged particles. Mezhv. Sb. Metody, Pribory i Sistemy Kontrolya Proizvodstvennoi Sredy. Leningradskii Elektrotekhnicheskii Institut. Leningrad, No.103, p.21-29 (in Russian).
- Popov, B.I., Rumyantsev, V.V. and Turubarov, V.I. (1976) Measurement of dust spatial concentration. In Metody, Pribory i Sistemy Kontrolya Proizvodstvennoi Sredy. Leningradskii Elektrotekhnicheskii Institut. Leningrad, p.50-54 (in Russian).
- Priiman, R. and Kikas, Ü. (1985) On the formation of submicron particles accompanied by ultraviolet irradiation of air. Acta et Comm. Univ. Tartuensis, No.707, p.94-101.

- Pui, D.Y.H., Fruin, S. and McMurry, P.H. (1988) Unipolar diffusion charging of ultrafine aerosols. *Aerosol Sci. and Technology*, vol.8, p.173-187.
- Pui, D.Y.H. and Liu, B.Y.H. (1988) Advances in instrumentation for atmospheric aerosol measurement. *Physica Scripta*, vol.37, No.2, p.252-269.
- Raunemaa, T., Kuuspalo, K., Alander, T. and Mirme, A. (1992) Size dependent particle removal of an air electrical cleaning system for buildings determined by EAA and EAS analysis. *J. Aerosol Sci.*, Vol.23, Suppl.1, p.791-794.
- Raunemaa, T., Kuuspalo, K., Alander, T., Tamm, E., Mirme, A. and Laine, V. (1993) Black carbon and aerosol in Boistö island. *J. Aerosol Sci.*, Vol.24, Suppl.1, p.S29-S30.
- Rebane, K.-S., Saks, O. and Shulichenko, E. (1987) 25 years of electrometrical research at Tartu State University. *Acta et Comm. Univ. Tartuensis*, No.755, p.126-133 (in Russian).
- Rohman, H. (1923) Methode zur Messung der Grösse von Schwebe-
teilchen. *Zs. Phys.*, vol.17, p.253-265.
- Schmidt-Ott A. (1991) New developments in aerosol characterization from the physical point of view. *Part. Syst. Syst. Charact.*, vol.8, p.35.
- Sinclair, D. (1986) Measurement of nanometer aerosol. *Aerosol Sci. and Technology*, vol.5, p.187-204.
- Smerkalov, B.A. (1984) Approximation of mean size distribution of aerosol particles. *Izv. AN SSSR, Fizika atmosfery i okeana*, vol.20, No.4, p.317-320 (in Russian).
- Smirnov, V.I. (1984) On the mechanisms responsible for the formation of typical size spectra and vertical distribution of tropospheric aerosol particles. 11th Int. Conf. on Atmospheric Aerosols and Ice Nuclei. Budapest, vol.1, p.82-86.
- Surakka, J. and Ruuskanen, J. (1993) Black carbon concentration measurements in ambient air. Proc. 1st Finnish Conference of Environmental Sciences. Kuopio, p.276-278.
- Takahashi, K. (1971) Numerical verification of Boltzmann's distribution for electrical charge of aerosol particles. *J. Colloid Interface Sci.*, vol.35, No.3, p.508-510.

- Tamm, E.I. and Fischer, M.M. (1973) Determination of size and charge of aerosol particles within the radii range of 0.35-1.2 μm with ultramicroscopic (trajectory) method. *Acta et Comm. Univ. Tartuensis*, No.320, p.109-128 (in Russian).
- Tamm, E. (1973) An experimental set-up for production of monomobile aerosols and the determination of their parameters. *Acta et Comm. Univ. Tartuensis*, No.320, p.139-162 (in Russian).
- Tamm, E.I. (1975) On functional charging of aerosol particles. *Acta et Comm. Univ. Tartuensis*, No.348, p.35-55 (in Russian).
- Tamm, E.I., Mirme, A.A. and Tammet, H.F. (1981) Aerosol granulometer. Patent USSR, G01N15/02, No.890156, Prior. 28.03.80., Bull. No.46 (in Russian).
- Tamm, E. (1986) Nonpublished manuscript
- Tamm, E.I., Tamme, V.B., Kikas, Ü.E., Peil, I.A., Mirme, A.A. and Langus, L.E. (1986) A system for obtaining etalon aerosols in the range of 10 nm to 10 μm . In *Aktualnye Voprosy Fiziki Aero-dispersnykh Sistem. Tez. Dokl. XIV Vses. Konf. Odessa*, vol.2, p.102 (in Russian).
- Tamm, E., Langus, L. and Mirme, A. (1987) Checking of the operation of the electric aerosol separator in the range of large particle size. *Acta et Comm. Univ. Tartuensis*, No.755, p.98-105 (in Russian).
- Tamm, E., Mirme, A. and Kikas, Ü. (1988) Corona discharge as a generator of monodisperse aerosols in the nanometer range. *Acta et Comm. Univ. Tartuensis*, No.824, p.123-131 (in Russian).
- Tamm, E. (1992) Electrical classification as a basis of the aerosol standard. *J. Aerosol Sci.*, Vol.23, Suppl.1, p.285-288.
- Tamm, E. and Mirme, A. (1992) Time variations and evolution of urban aerosol particle size spectrum. In *European Aerosol Conference. Single Page Abstracts. Oxford*. p.O27.
- Tamm, E., Kikas, Ü. and Mirme, A. (1992) Electrical classification as a basis of the aerosol standard. In *European Aerosol Conference. Single Page Abstracts. Oxford*. p.255.
- Tamm, E., Mirme, A. and Kikas, Ü. (1992) Corona discharge as a generator of nanometer-range monodisperse aerosol. *Acta et Comm. Univ. Tartuensis*, No.947, p.80-88.

- Tamme, V. and Koppelmaa, I. (1987) Vibrating generator of monodisperse aerosols. *Acta et Comm. Univ. Tartuensis*, No.755, p.113-119 (in Russian).
- Tammet, H. (1969) Volt-ampere characteristics of an ideal unipolar quasi-corona. *Acta et Comm. Univ. Tartuensis*, No.239, p.3-40 (in Russian).
- Tammet, H. (1970) *The Aspiration Method For The Determination of Atmospheric-Ion Spectra*. Jerusalem, 208 p.
- Tammet, H.F., Jakobson, A.F. and Salm, J.J. (1973) Multichannel automatic air ion spectrometer. *Acta et Comm. Univ. Tartuensis*, No.320, p.48-75 (in Russian).
- Tammet, H.F. (1973) On the problem of the resolving power in spectral analyse. *Acta et Comm. Univ. Tartuensis*, No.320, p.76-100 (in Russian).
- Tammet, H.F. (1975) *Introduction To The Finite-Dimensional Linear Theory Of Spectrometry*. Valgus, Tallinn, 100 p. (in Russian)
- Tammet, H.F. (1975a) On the electrical aerosol granulometry. *Acta et Comm. Univ. Tartuensis*, No.348, p.30-34 (in Russian).
- Tammet, H.F. (1980) On the techniques of aerosol electrical granulometry. *Acta et Comm. Univ. Tartuensis*, N.534, p.55-79 (in Russian).
- Tammet, H.F. (1980a) A piece-wise linear model of the spectrum for the measurement of air ions and aerosols. *Acta et Comm. Univ. Tartuensis*, No.534, p.45-54 (in Russian).
- Tammet, H.F., Mirme, A.A. and Tamm, E.I. (1983) Electric analysis of aerosols. *Tr. In-ta Eksperimentalnoi Meteorologii*. Moscow, No.30(104), p.122-136 (in Russian).
- Tammet, H.F. (1983a) Calibration of an electrical aerosol granulometer using the distribution of collected particles. *Acta et Comm. Univ. Tartuensis*, No.648, p.52-58 (in Russian).
- Tammet, H.F. and Noppel, M.G. (1984) Principles of calibration of electric aerosol granulometer. In *Metody i Pribory Kontrolya Parametrov Biosfery*. Mezhvuz. Sb. Leningrad, p.21-28 (in Russian).
- Tammet, H. (1988) The use of aerosol particle charger as an additional device to air ion counter. *Acta et Comm. Univ. Tartuensis*, No.809, p.127-136 (in Russian).

- Tammet, H. (1988a) Comparison between model distributions of aerosol particle sizes. *Acta et Comm. Univ. Tartuensis*, No.824, p.92-108 (in Russian).
- Tammet, H. (1988b) Models of size spectrum of tropospheric aerosol. *Lecture Notes in Physics*, No.309, p.75-78.
- Tammet, H.(1992) Comparison of model distributions of aerosol particle sizes. *Acta et Comm. Univ. Tartuensis*, No.947, p.136-149.
- Tammet, H. (1992a) On the techniques of aerosol electrical granulometry. *Acta et Comm. Univ. Tartuensis*, No.947, P.94-115.
- Tammet, H. (1992b) Size-mobility relation for ultrafine particles. In *European Aerosol Conference. Single page abstracts*. Oxford, p.139.
- Tammet, H. and Noppel, M. (1992) Principles of the graduation of an electric aerosol granulometer. *Acta et comm. Univ. Tartuensis*, No.947, P.116-124.
- Tikhonov, A.N. (1985) About methods of automatic data processing. In *Matematicheskoe Modelirovanie, Programmirovaniye i Matematicheskie Metody Resheniya Fizicheskikh Zadach*. Tr. Mezhdunar. Soveshch. Dubna, p.11-22 (in Russian).
- Tikhonov, A.H. and Arsenin, V.Ya. (1986) *Methods For Solving Incorrect Problems*. Moscow. Nauka (in Russian).
- Ulevicius, V., Juozaitis, A., Balsys, A., Girgzdys, A. (1988) An electrical aerosol spectrometer. *Proc. of Institute of Physics of the Academy of Sciences of the Lithuanian SSR; Atmospheric Physics*, Vol. 12; *Admixtures in the environment*, Vilnius, p. 177-184.
- Vijayakumar, R. and Whitby, K.T. (1984) Bipolar steady state charge fraction of ultrafine aerosols. *Aerosol Sci. and Technology*, vol.3, No.1, p.25-30.
- Visnapuu, L.J. and Mirme, A.A. (1979) Device for the generation of monodisperse drops. Patent USSR, B05B17/06, No.676330, Prior. 30.03.78., Bull. No.28 (in Russian).
- Voloshchuk, V.M. and Sedunov, Yu.S. (1975) *Coagulation Processes In Dispersed Systems*. Leningrad (in Russian).
- Wang, S.C and Flagan, R.C. (1989) Scanning electrical mobility spectrometer. *Aerosol Sci. and Technology*,

- Whitby, K.T., Liu, B.Y.H. and Peterson, C.M. (1965) Charging and decay of monodispersed aerosols in the presence of unipolar ion sources. *J. Coll. Sci.*, vol.20, p.585-601.
- Whitby, K.T. and Clark, W.E. (1966) Electric aerosol particle counting and size distribution measuring system for the 0.015 to 1 μm size range. *Tellus*, vol.18, No.2, p.573-586.
- Whitby K.T. and Liu B.Y.H. (1969) Atmospheric aerosol size distribution. *Proc. 7th Int. Conf. on Condensation and Ice Nuclei*. Prague, Wien, Sept. Academia, p.26-37.
- Willeke, K. and Baron, P.A. (1992) *Aerosol Measurement. Principles, Techniques, and Applications*. Van Nostrand Reinhold.
- Winklmayr, W., Wang, H.-C. and John, W. (1990) Adaptation of Twomey algorithm to the inversion of cascade impactor data. *Aerosol Sci. and Technology*, vol.13, p.322-331.
- Winklmayr, W., Reischl, G.P., Lindner, A.O. and Berner, A. (1991) A new electromobility spectrometer for the measurement of aerosol size distributions in the size range from 1 to 1000 nm. *J. Aerosol Sci.*, vol.22, p.289.
- Wolfenbarger, J.K., and Seinfeld, J.H. (1990) Inversion of aerosol size distribution data. *J. Aerosol Sci.*, vol.21, p.227-247.
- Wolfenbarger, J.K., and Seinfeld, J.H. (1990) Inversion of aerosol size distribution data. *J. Aerosol Sci.*, vol.21, p.227-247.
- Yoshikawa H.H, Swartz G.A., MacWaters J.H. and Fite W.L. (1956) Electrostatic particle size analyser. *Rev. Sci. Instr.*, vol.27, No.6, p.359-362.
- Zagainov, V.A., Lushnikov, A.A., Biryukov, Yu.G., Uspalenko, T.G., Kikas, Ü., Mirme, A. and Tamm, E. (1987) Investigation of the formation of high-dispersity aerosol particles in corona discharge. In *Tez. Dokl. V Vses. Konf. "Aerozoli i Ikh Primenenie v Narodnom Khozyaistve"*. Moscow, vol.1, p.37-37 (in Russian).
- Zeleny, J. (1901) The velocity of the ions produced in gases by Röntgen rays. *Philos. Trans. Roy. Soc. A*, vol.195, p.193-234.
- Zinsmeister, A.R. and Redman, T.C. (1980) A time series analysis of aerosol composition measurements. *Atmospheric Environment*, vol.14, p.201-215.

presents the of spectrometer response to a basis spectrum. The elements of the matrix are increased by the factor presented in the row H:.

2. EAS record printout.

EAS TU No. 4 DATA=1994 5 25 TIME=19 59 59

DG	24	25	26	27	28	29	30	31
0	-49	-102	99	401	803	1023	495	807
1	-50	-101	100	403	810	-23	480	806
0	-49	-100	99	402	805	1023	490	808

SIG

1)	0.41	0.02			
2)	0.02	0.02			
3)	1.80	0.04	15)	8.22	0.03
4)	3.74	0.05	16)	9.34	0.03
5)	8.51	0.86	17)	10.68	0.04
6)	21.19	0.08	18)	12.74	0.26
7)	33.80	0.27	19)	12.12	0.03
8)	82.60	1.42	20)	11.07	0.10
9)	111.73	2.64	21)	8.58	0.13
10)	107.39	2.04	22)	2.90	0.01
11)	92.56	0.98	23)	30.13	14.62
12)	69.66	0.58	24)	5.99	0.65
13)	46.86	0.25	25)	2.87	0.02
14)	30.77	0.28	26)	0.88	0.03

The first row presents the spectrometer version number, current date and time, respectively. The section DG consists of the spectrometer operational data. The section SIG presents the apparatus record in the form; the channel number, the estimated electric current in the units of 10^{-15} A and the electric current dispersion in the units $(10^{-15} \text{ A})^2$.

3. EAS spectrum printout.

EAS TU No. 4 DATA=1994 5 25 TIME=19 59 59

D	N	SN
(nm)	(1/cm ³)	(1/cm ³)
10 - 18	32.46	19.44:*****
18 - 32	598.80	28.75:*****
32 - 56	1715.06	24.30:*****
56 - 100	2567.56	28.29:*****
100 - 178	1218.39	10.02:*****
178 - 316	313.29	3.48:*****
316 - 562	80.64	0.73:*****
562 - 1000	11.64	0.16:*****
1000 - 1778	1.02	0.07:*****
1778 - 3162	0.53	0.06:*****
3162 - 5624	0.11	0.01:**
5624 - 10000	0.01	0.00:

The first row presents the version number, date and time. The spectrum is presented as a distribution of fraction concentrations in the form; the fraction limits, the estimated number concentration of particles in particles per cm³ of the fraction and the standard deviation of the estimate. The distribution is visualised by asterisks on the logarithmic scale.

ACKNOWLEDGEMENTS

This work was carried out at the Air Electricity Laboratory of Tartu University in 1976 - 1993.

Among the people who contributed to my studies I would first like to mention Nikolai Fuchs as it was his suggestion that an instrument for aerosol distribution measurement should be designed.

I wish to thank Professor Hannes Tammet who provided the basis for this work. Great part of the work is based on his ideas and his approach to spectrometry problems.

I should like to thank Professor Eduard Tamm for his support and help, both, direct and indirect.

I wish to thank Ülle Kikas as she provided me with excellent aerosols and was the heart and soul of the aerosol group.

I am also grateful to Madis Noppel, Aivo Reinart, Indrek Peil, Valdek Tamme and other members of the aerosol group for their contribution.

I would thank Arno Vall for it was his experience and skill that helped me to convert the ideas into reality and build instrumentation of high quality.

I also thank the other members of the laboratory; Linda Langus, Ilmar Lipping, Toomas Koger, Jaan Öövel, Jaan Maasepp, Rein Matisen, Aleksei Zaharov, Aleksander Zalivin and others for their invaluable help at the different stages of the work. My thanks go to Feliks Miller for designing the electrometers.

My special thanks are directed to Toomas Bernotas for the building, adjustment and maintenance of electronics.

I would like to mention with great thanks the first head of our laboratory Jaan Reinet as he set up our well working team.

Finally I am very thankful to my wife Aili and son Sander for their infinite patience and ever-present support during all those long days when I used to come home very late.

ELEKTRILINE AEROSOOLISPEKTROMEETRIA

Resümee

Aerosoolil on oluline roll atmosfääriprotsessides. Ta on ka üks keskkonnasaaste komponent.

Töös on vaadeldud elektriliste aerosoolimõõtmismeetodite rakendatavust atmosfääriaerosooli esmase karakteristiku; aerosooliosakeste suuruse järgi jaotuse määramiseks. Elektriliste meetodite potentsiaalsete, osakeste suuruse järgi lahutavuse ja kontsentratsioonitundlikkuse analüüsi tulemusena on välja töötatud elektriliste meetodite kombinatsioon, mis võimaldab luua atmosfäärivaatlusteks sobiva aerosoolispektromeetri. Väljatöötatud spektromeetri tehniline lahendus võimaldab määrata atmosfääriaerosooli mõõtmisperioodi keskmise jaotuse osakeste suuruste vahemikus 10 nm kuni 10 μ m. Rakendatud mõõtmise ja andmetöötluse meetodid võimaldavad paindlikku mõõtmisprotsessi. Vajaliku mõõtmistäpsuse saavutamiseks on rakendatud kalibratsioonimeetodeid, mis kasutaksid efektiivselt kogu kättesaadavat teoreetilist ja eksperimentaalset informatsiooni. Parimaid tulemusi on saavutatud meetoditega, mis arvestavad nii mõõtmise vigu kui ka aerosoolide karakteristikute ebatäpsust.

Spektromeetriga teostatud uurimused on võimaldanud detailselt jälgida aerosooli käitumist atmosfääris, sealhulgas aerosoolijaotuse ööpäevase käigu sõltuvust keskkonna antropogeensest saastatusest. Väljatöötatud atmosfääriaerosooli variatiivsuse mudel seob omavahel mõõdetud aerosooli ajalised korrelatsioonifunktsioonid, aerosooliosakeste eluea ja atmosfääri turbulentsse segunemise karakteristikud, võimaldes hinnata aerosoolse saaste allikate jaotust looduses. Aerosoolijaotuse ja tahma (vaba süsiniku) summaarse kontsentratsiooni variatiivsuste statistilise analüüsi abil on hinnatud tahma jaotust aerosooliosakestes, mis annab informatsiooni põlemisaerosooli allikate kohta.

Meetodi abil, mis põhineb aerosoolijaotuse kiire muutumise mõõtmisel, on määratud ruumide puhastamiseks ettenähtud, elektrituulel põhineva aerosoolifiltri karakteristikuid natuurtingimustes.

Aerosooli tekkeprotsesse on uuritud koroonalahenduse baasil. On määratud erineva polaarsusega koroonalahendustes genereeritava aerosooli parameetrite sõltuvus koroonalahenduse parameetritest.