

UNIVERSITY OF TARTU
FACULTY OF SCIENCE AND TECHNOLOGY
INSTITUTE OF TECHNOLOGY

Jaanus Kalde

UHF COMMUNICATION SYSTEM FOR CUBESATELLITE

Master's thesis (30 EAP)

Supervisors:
Assistant professor Mart Noorma
MSc Viljo Allik

Tartu 2015

Table of contents

Abbreviations.....	4
1. Introduction.....	5
2. Background information.....	6
3. Previous solutions.....	9
3.1. ESTCube-1 communication system.....	9
3.2. Commercial systems.....	12
4. Requirements.....	13
4.1. Link budget.....	14
5. Technical solution.....	16
5.1. Transceiver.....	18
5.1.1. Oscillator.....	19
5.2. Power amplifier.....	20
5.2.1. TriQuint TQP7M9105.....	23
5.2.2. ST PD84002.....	24
5.3. Filters.....	26
5.3.1. Low-pass antenna filter.....	26
5.3.2. Receive input filter.....	31
5.4. Circuit board layout.....	33
6. Tests.....	35
7. Summary.....	36
8. References.....	37
9. Kokkuvõte.....	40
Appendix 1 – Comparison of communication systems.....	41
Appendix 2 – Electrical schematic.....	42
Appendix 3 – Board layout.....	45

List of figures

Figure 1: System overview of ESTCube-1 communication system.....	11
Figure 2: Top level diagram of the communication system.....	16
Figure 3: Simplified schematic of the amplifier circuit.....	20
Figure 4: linSmith impedance matching program showing output matching circuit.....	21
Figure 5: Test board for TQP7M9105 amplifier and antenna switch.....	23
Figure 6: Test board for PD84002 amplifier.....	25
Figure 7: Filter schematic in QUCS.....	27
Figure 8: Simulated insertion loss to frequency graph with -1 dB cutoff frequency label.....	28
Figure 9: Test setup to measure filter in real system.....	29
Figure 10: Measured low-pass filter insertion loss graph with marker at cutoff frequency.....	30
Figure 11: Measurement of the low pass filter in 100 MHz to 1.8 GHz frequency range.....	31
Figure 12: Attenuation graph of helical filter in the 100 MHz to 1.8 GHz frequency range.....	32
Figure 13: First integrated prototype of the communication system.....	35

List of tables

Table 1: Link budgets for up and downlink.....	15
Table 2: Comparison of transceivers.....	18
Table 3: Input matching networks tried for TQP7M9105.....	24
Table 4: Output matching circuit values and measured efficiency of PD84002.....	25
Table 5: Communication board PCB stack-up.....	33

Abbreviations

AFC	- Automatic frequency compensation
ASK	- Amplitude-shift keying, a form of digital amplitude modulation
CAN	- Controller area network, a common vehicle bus
DAC	- Digital-to-analog converter
EPS	- Electrical power system
FRAM	- Ferroelectric random-access memory
(G)FSK	- (Gaussian) Frequency-shift keying, a form of digital frequency modulation
(G)MSK	- (Gaussian) Minimum-shift keying, a form of digital frequency modulation
GS	- Ground station, station on earth communicating with satellite
I2C	- Inter-integrated circuit, a multipoint serial bus
MCX	- Micro coaxial, a type of RF connectors
MCU	- Microcontroller
OOK	- On-off keying, a simple digital amplitude modulation
PCB	- Printed circuit board
UART	- Universal asynchronous receiver/transmitter, serial communication protocol
UHF	- Ultra high frequency, frequency band covering from 300 to 3000 MHz
VHF	- Very high frequency, frequency band covering from 30 to 300 MHz
RF	- Radio frequency
SPI	- Serial Peripheral Interface, synchronous serial communication bus
QUCS	- Quite Universal Circuit Simulator

1. Introduction

This masters thesis covers design and prototyping of a ultra high frequency communication system for CubeSats. Design is based on the requirements set by Estonian next proposed satellite ESTCube-2.

CubeSat is a small satellite standard that is widely used for research and educational purposes. Most satellites need a way to communicate with Earth to allow sending commands to the satellite and receiving telemetry and mission data.

The goal of this thesis is to design and prototype a communication system suitable for CubeSats. It covers calculating link budgets, deciding the system architecture, choosing and testing all required components and designing first integrated prototype. Communication system has to be designed to work in space environment and meet all the needed requirements. Space and CubeSats have numerous design limitations, especially in size and energy usage.

2. Background information

CubeSat is a miniaturized picosatellite standard. CubeSat standard defines base satellite unit(U) with 10 cm x 10 cm x 10 cm size and up to 1.3 kg weight [1]. From the base unit size there are defined multiple satellite sizes like 2 U, 3 U, 6 U etc. Launching and mechanical construction is standardized for CubeSats. This makes them much cheaper and easier to launch to orbit than regular satellites. Standard subsystems have created a market for components - thus lowering price and furthering innovation. Such tiny picosatellites are mainly used for education and component testing. European Space Agency, NASA [2] and several universities have their educational CubeSat programs. Most widely known such program in Estonia is probably Estonian Student Satellite Program program.

There are also companies that use these miniature CubeSats instead of big satellites to provide services for their clients. For example American company Planet Labs, whose satellite constellations Flocks use three unit CubeSats called Doves, to provide real time visible spectrum imaging of planet Earth [3].

ESTCube-1 was first Estonian satellite - built by students with its main purpose being education. It was 1 U CubeSat, with main scientific goal to test electric solar wind sail [4]. Electric solar wind sail is a novel proposed space propulsion method. Like other solar wind sail propulsion methods - it works by deflecting plasma originating from the sun. These kinds of propulsion methods are low thrust. But their major advantage is that they do not require propellant, thus providing acceleration times limited only by spacecraft lifetime. This allows building light and small spacecraft with big manoeuvring capabilities. Electric solar wind sail one type of solar wind sail. It uses one or multiple tethers, charged to a high voltage potential to generate electric field. This electric field is used as a sail surface to provide force.

ESTCube-2 is a planned satellite to test out solar wind sail in low Earth orbit. The mission needs a communication subsystem to transmit commands to the satellite and download experiment data to ground stations on the ground. Mission details are not yet fixed at the moment, but basic requirements to develop communication system have been agreed on. It will be a low Earth orbit satellite with altitude in the order of magnitude of 350 km.

Electronic systems in Earth orbit are in different environment than normal Earth systems. One of the biggest difference is accessibility - once the satellite is in orbit it cannot be repaired

physically. Second important difference is the lack of atmosphere. It changes thermal management as heat transfer by convection is no longer available. It also has other effects. It produces stress to all closed containers. Also many plastics and similar materials release gases in vacuum that may contaminate optics and other sensors. From mechanical standpoint the launch to the orbit is the most important. All satellite components must survive vibrations and shocks that come from launching the satellite with rocket.

One of the limiting aspects of CubeSats is their size and weight. Very small size of the whole satellite puts limits on the size on the subsystems. Many satellites use PC/104 mechanical form factor – 90 mm x 96 mm sized cards stacked on top of each other. Subsystems are divided between the cards and communicate through stack connector. Very limited size also means limited surface area – which in turn, little power generation. On ESTCube-1 power generation during sunlight was between 2.4 to 3.4 W. This very little power means that all subsystems have to be as efficient and low power as possible. This kind of power budget limits power available for communication and payloads [5].

One of the most important aspect of any communication system terrestrial or orbital is the operating frequency band. Electromagnetic spectrum is a finite and global resource. It is very important topic to satellites because satellites can transmit above many different countries and the signal cannot interfere any other application. Global frequency allocation is done by International Telecommunication Union and allocating frequency band can take more than five years and can be costly. Since most CubeSats are built on limited time scale and budget many of the educational and scientific ones use radio amateur frequencies. Getting an allocated radio amateur frequency from governing International Amateur Radio Union easier progress, but has its own requirements. All communication on the amateur bands must be non-encrypted and documented publicly.

For wireless communication modulation is also an important aspect. Modulation defines the way information is encoded to radio signals [20]. The most simple modulation is on-off keying – turning carrier frequency on and off. This modulation is not very robust, but is used in amateur radio for sending low speed Morse coded signals. This was used in ESTCube-1 safe mode beacon to provide basic telemetry information, that would be simple to receive and decode. Frequency-shift keying is widely used digital modulation. It decodes information to change of the frequency. The most simple version of it – binary frequency-shift keying (BFSK/2FSK)

modulation uses two different frequencies, where one frequency means digital one and another a digital zero. It is also possible to use more than two frequencies – for example QFSK uses four.

Space communication differs from terrestrial communication in several ways. The most challenging aspect about it is the distance. Satellites in low Earth orbit are between 300 to 1000 km above the surface of the planet. This means that free space loss in the communication path is substantial. At higher frequencies atmospheric losses also play a role. High speed that the satellite is moving causes Doppler effect. Transmitting frequency received from the ground station is changing according to the speed of the satellite compared to listener. Big telecommunication satellites have built in Doppler correction. For small satellites this compensation is made in ground station.

To still have good connection with satellite even after these losses the ground stations for satellites usually have high gain parabolic or Yagi antennas and use high power for transmitting. These antennas point towards the satellite the whole communication time. Some aspects of the communications are easier compared to terrestrial. Terrestrial communications usually have reflection and losses from other objects on the ground. Space communications usually have line of sight communications with no additional losses or reflections. This allows the use of simple narrow band modulations instead of more complex multipath ones.

Many of the radio measurements made in this work were done with Hewlett-Packard 4396A network analyser. Network analyser is a radio measuring device that combines spectrum analyser and tracking generator. Spectrum analyser allows to measure and plot radio spectrum in one frequency range. Tracking generator adds functionality to do more complex measurements like insertion loss and phase shift measurements over a frequency range and measuring reflected RF power and phase shift do determine input matching.

3. Previous solutions

Communication system designed for this thesis work is based on ESTCube-1 communication subsystem. This subsystem is working successfully on the orbit and is used for telemetry and image data transfer. It was designed by Andres and Toomas Vahter.

Before designing this system commercial systems were considered and researched to provide comparison to ESTCube-1 and new solutions.

3.1. ESTCube-1 communication system

ESTCube-1 communications system is a half duplex system that uses different frequency bands for uplink and downlink. System architecture and connections between components are shown in figure 1 [18]. For downlink 9600 baud 430 MHz UHF frequency was used. Maximum output power for downlink is 0.5 W / 27 dBm. For uplink - 1200 baud 143 MHz VHF [7]. Both links are fixed baud and use 2FSK modulation with 25 kHz bandwidth. System also had separate 0.1 W / 20 dBm OOK Morse beacon downlink that is directly controlled by power system to provide backup communication channel.

Transmit and receive circuits had separate ADF7021 transceivers. Separate Morse beacon was generated with Silicon Labs Si570 programmable crystal oscillator. Downlink was amplified to necessary level with programmable gain power amplifier RFPA0133. Receiving input has RFMD SGL0363Z low noise amplifier with theoretical noise figure of 1.1 dB [13]. Both channels had separate antenna connectors so there was no need for RF switching. Transmit circuit had the ability to measure transmitted and reflected RF power using directional couplers and logarithmic amplifiers.

ESTCube-1 used two monopole antennas. Monopole antennas were used because their ease of construction and since they are omnidirectional. Scientific mission required satellite to spin and still have a communication link. This determined the use of omnidirectional antenna.

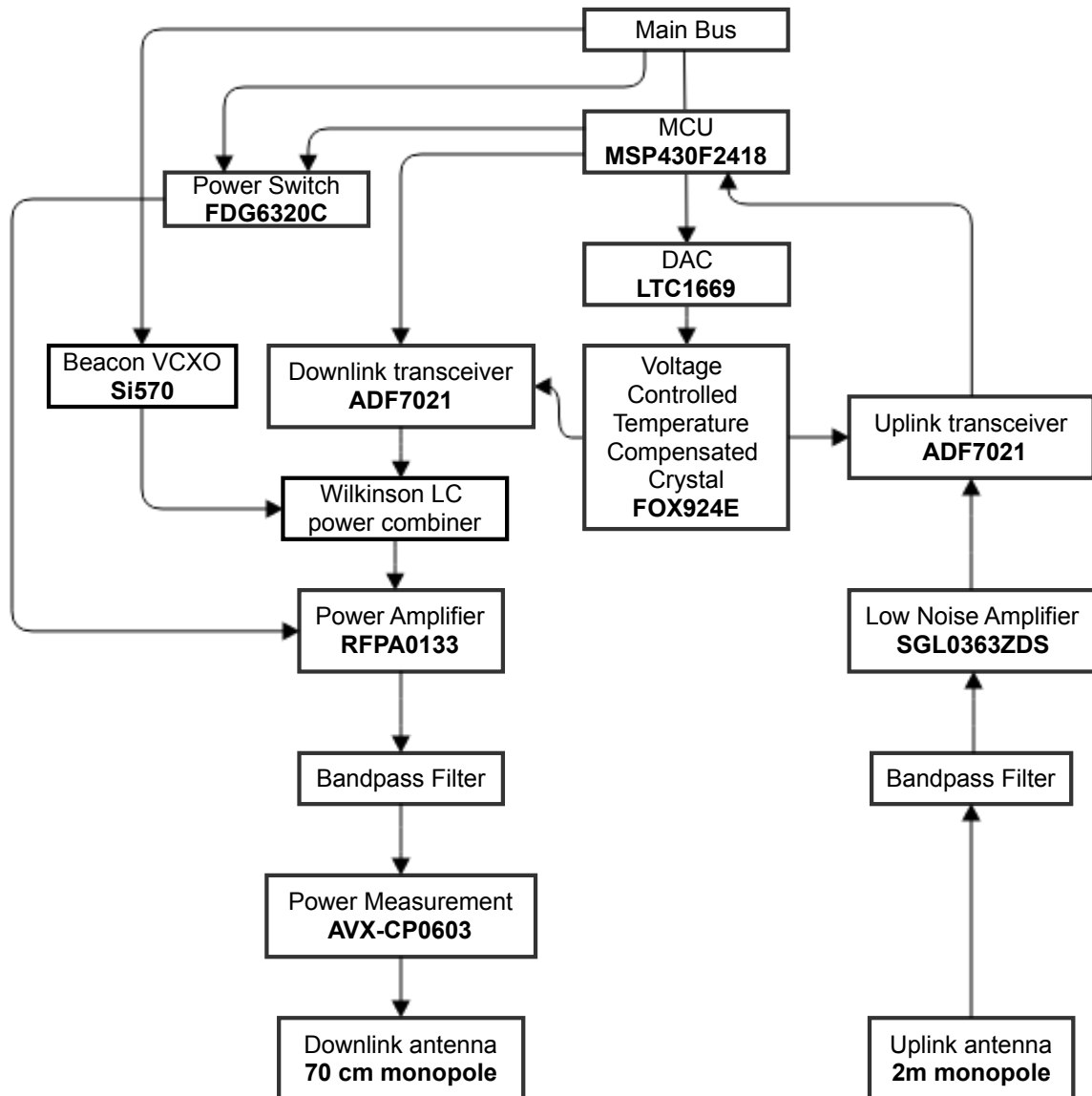

Figure 1: System overview of ESTCube-1 communication system

One of the major components that needs to be changing in the new development is the transceiver chip. ADF7021 was not directly compatible with AX.25 protocol, thus requiring special hardware for communication.

3.2. Commercial systems

A list of four commercial transceivers were considered as a reference. GomSpace NanoCom AX1000 and U482C, Clyde Space UTRX and ISIS Full Duplex Transceiver. Full comparison table is in the appendix 1. All of the commercial modules supported speeds from 1200 to 9600 with AX100 supporting up to 115200 bps transmit speeds. All modules used I2C with AX100 being the only one to support a fault tolerant industrial communication bus – CAN. The AX100 module was only system that was not compatible with PC/104, but offered support board that makes it possible to combine the module and one more module on one PC/104 card.

None of the communication systems were designed to be very efficient – for all of the systems less than half of the power consumed during transmit goes to RF output. From modulation standpoint – two of the four systems offered constant wave beacon output, three of the systems had FSK modulation and only supported had phase shift keying (PSK) modulation. FSK modulation is more widely used in narrow band applications, although PSK offers better data rates for same signal to noise ratio.

4. Requirements

For the finished system there are several top level requirements. It has to conform with ESTCube-2 technical requirements: power, voltages, internal communication and mechanical. Also – in order to commercialise this as a product after development it has to provide better value than existing commercial systems on the market.

ESTCube-2 system bus sets numerous requirements that the communication system has to comply.

- Mechanical layout has to match required dimensions and have necessary fixing holes
- System bus has to have specific connector specified with correct pinout
- System has to use available voltages – 3.3 V, 5 V, 12 V, unregulated 8 V.
- System is required to have two independent RS-485 buses.
- Main microcontroller (MCU) has to be same as in other subsystems to maximize code portability

It also has several radio requirements it has to comply:

- International Amateur Radio Union rules allow satellite communication multiple frequency ranges. Two way ultra high frequency communication is allowed in the frequency range 435-438 MHz [6].
- It has to provide 1 W / 30 dBm of RF power output to antenna
- It has to have OOK modulation output capability for safe mode beacon
- System has to have two-way binary Gaussian frequency-shift keying (2GFSK) communications
- Has to have standard AX.25 9600 baud radio amateur mode
- Provide changeable on air baud rates from 9600 to 38400 bps

4.1. Link budget

Link budgets are used to calculate different aspects of communication systems. Link budget accounts of all aspects of the telecommunication link. It consists of transmitter parameters, losses in the transmitter, transmitting medium and receiver. It also incorporates receiver parameters and link data rate [19]. It is used to find theoretical maximum data rate of a link. For a given bit rate it is also possible to calculate link margin that gives indication of robustness of the communication.

First part of the calculation is calculating transmitter Equivalent Isotropic Radiated Power (EIRP) – metric of radiated power from the antenna. Second part of the calculation consists of calculating all transmission and receiving losses. Then it is possible to calculate signal to noise ratio for current bit rates. Finally link margin can be calculated.

Formula used to calculate EIRP is:

$$EIRP = P_T - L_T + G_T$$

Where P_T is transmission power, L_T is transmission loss and G_T is transmitter antenna gain.

Then propagation losses are calculated:

$$L_{prop} = FSL + L_{abs}$$

Where L_{abs} is atmospheric absorption and FSL is free space loss what is calculated:

$$FSL = \left(\frac{4\pi df}{c} \right)^2 = 20 \log_{10}(d) + 20 \log_{10}(f) - 147.55$$

Formula to calculate received power from the antenna is:

$$P_r * G = EIRP - L_{prop} + G$$

Where G is receive antenna gain, L_{prop} is propagation losses and EIRP is equivalent isotropic radiated power.

Last step is to calculate received signal to noise ratio per bit:

$$E_b/N_0 = P_r * G - 10 \log(rb) - k - 10 \log(T_s)$$

Where Boltzmann constant $k = -198,6$ dBm/K, T_s is system noise temperature and rb is bit rate.

Link margin can be calculated:

$$\text{Link margin} = E_b/N_0 - \text{Required } E_b/N_0$$

For 2FSK modulation with error rate less than 10^{-5} the required E_b/N_0 is 14.2 dB.

For link budget satellite antenna is chosen to be dipole with gain of 2.15 dBi. Ground station is calculated to use four 7 meter long Yagi antennas with gain of 22 dBi and using 20 W (43 dBm) power amplifier.

Parameter	Value						Unit
	Downlink (9600 bps)		Downlink (38600 bps)		Uplink		
	Zenith	Horizon	Zenith	Horizon	Zenith	Horizon	
Transmitter							
Transmit power (P_T)	30				43		dBm
Transmission loss (L_T)	4				2,7		dB
Transmitter antenna gain (G_T)	2,15				22		dBi
Equivalent Isotropic Radiated Power (EIRP)	28,15				62,3		dBm
Propagation losses							
Distance (d)	350	2000	350	2000	350	2000	km
Free Space Loss (FSL)	136	152	136	152	136	152	dB
Atmospheric absorption (L_{abs})	1	2	1	2	1	2	dB
Polarization loss	3						dB
Total path loss (L_{prop})	140	157	140	157	140	157	dB
Receiver							
Receive antenna gain (G)	22				2,15		dBi
System noise temperature (T_s)	550				1300		K
Boltzmann constant (k)	-198,6						dBm/K/Hz
Received power ($P_r * G$)	-89,9	-106,9	-89,9	-106,9	-75,6	-92,6	dBm
Bit rate (rb)	9600		38400		9600		b/s
Signal to noise per bit (E_b/N_0)	68,9	24,5	35,5	18,5	52,1	35,1	dB
Required E_b/N_0 for 2FSK	14,2						dB
Link margin	54,7	10,3	21,3	4,3	37,9	20,9	dB

Table 1: Link budgets for up and downlink

5. Technical solution

Main components that have to be in such system are microcontroller to control the system and handle packets, transceiver to convert data to radio frequency (RF) signals and back and power amplifier to boost signal to level necessary to reach earth.

Main bus connector provides power and communication lines for the system. 3.3 V and unregulated 8 V lines are available from Electrical power unit (EPS). For communication with rest of the satellite, two RS-485 interfaces are available from the main bus.

Between microcontroller and main bus there are two RS-485 interface transceivers to convert main communication interfaces to UART.

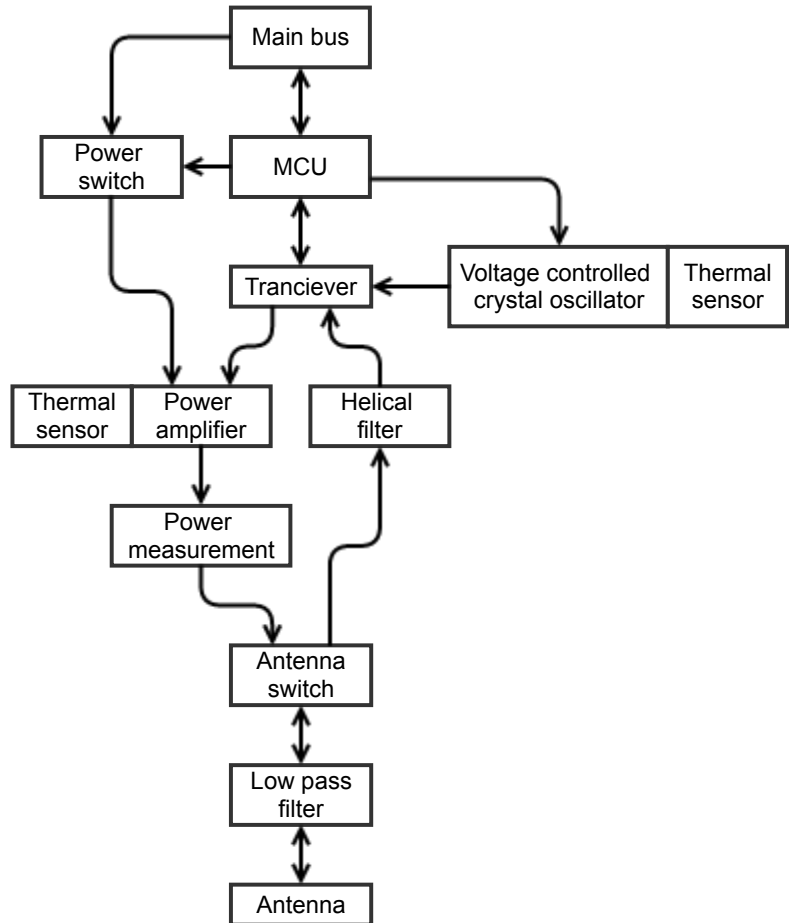

Figure 2: Top level diagram of the communication system.

Microcontroller controls all of the other components of the subsystem, communicates with other subsystems and decodes and buffers packets sent from ground station. Texas Instruments MSP430FR5969 was chosen as the microcontroller. It is a microcontroller based on low power and radiation tolerant ferroelectric random-access memory (FRAM) [8]. This microcontroller was the biggest in the FRAM MCU product line at the time and EPS uses the same controller. This microcontroller has two UART lines that can be used to satisfy double RS-485 requirement. Besides these two lines it also has a separate hardware SPI line that is used to communicate with transceiver, digital-to-analog converter and serial FRAM. This serial FRAM is used to store firmware images for bootloader support.

Radio frequency transceiver is set up by MCU to transmit and receive necessary RF signals. Stable clock to the transceiver comes from temperature compensated voltage controlled crystal oscillator. It is an crystal oscillator that outputs clipped sine wave. The oscillator is temperature compensated to make it more stable in changing temperature environment. Oscillator voltage control input is controlled by main microcontroller via digital-to-analog converter (DAC) to provide frequency tuning by command.

Transceiver has separate receive and transmit pins that are connected to different signal paths. Receive path is connected to antenna switch through band-pass filter. Transmitted signal goes through power amplifier to boost its strength to necessary levels. Power amplifier temperature is monitored, power can be switched and gain is controllable via DAC. Power amplifier output goes through two way power measurement to antenna switch. Power measurement circuit measures output and reflected power levels.

Antenna switch switches between transmit and receive signal paths. Between switch and antenna connector there is a low-pass filter for crude filtering. For attaching antenna cable there is a MCX connector.

The microcontroller is programmed in Code Composer Studio environment and programmed using Texas Instruments tool MSP-FET430UIF. The code is written in C and divided between different files per functionality to allow code reuse.

Antenna switch was chosen to be TriQuint TQP4M0010. It was chosen because of its availability, low insertion loss and easy to use 50 Ohm matched inputs and outputs [22]. Low insertion loss is important both for receive and transmit. For transmit – losses between amplifier and antenna mean that amplifier has to transmit more power and the system becomes less efficient. For receive insertion losses also have a bad effect – all losses between antenna and first amplifier increase system noise temperature.

There is also a Fairchild Semiconductor FPF2700 power switch between power bus and power amplifier. This power switch is used to turn off the power for the amplifier when not transmitting. This feature is necessary, because power amplifier consumes similar amount of energy irrespective to the state – amplifying or not.

5.1. Transceiver

One of the main components in communication system design is choosing transceiver. For this different ultra high frequency transceiver integrated circuits were research and compiled to a big comparison table. Short excerpt of this table, showing most important parameters is provided in table 2.

Transceiver	Modulations	Output power (dBm)	Sensitivity (dBm)
ADF7021	2..4FSK, MSK	13	-116
SI4438	(G)FSK, (G)FSK, OOK	20	-115
Si4455	(G)FSK	13	-115
Si446x	(G)FSK, 4(G)FSK, MSK, OOK	20	-126
Si10xx	FSK, GFSK, OOK	13/20	-121
SX1231H	FSK, GFSK, MSK, GMSK, OOK	20	-114
MRF49XA	FSK	7	-110
MAX7032	ASK, OOK, FSK	10	-107

Table 2: Comparison of transceivers

Out of the eight suitable components put in the table Silicon Labs Si4463 was chosen for the system. It was one of the components that allowed using FSK and OOK modulations. It was stocked and available from multiple distributors. From the suitable components it had the best sensitivity and high output power. High sensitivity allows not to use low noise amplifier in the receive path – thus simplifying the system. High output power makes driving output power amplifier easier. Si446x series chips are also used in HopeRF FSK modules, that have example code for many different platforms.

The transceiver has some other features that make it suitable for uses. Data rate can be from 100 bps to 1 Mbps [21], satisfying the baud rate requirement. It also has built in automatic frequency compensation (AFC) that allows to implement automatic Doppler shift correction. Automatic frequency compensation allows to measure how much does the received signal deviate from nominal signal because of Doppler shift. Then the communication system can compensate its own transmit frequency, thus eliminating need to do Doppler shift compensation on the ground station.

5.1.1. Oscillator

Temperature compensated voltage controlled crystal oscillator is used for precise frequency generation. Crystal oscillators consist of quartz crystal and amplification circuitry. Oscillators require power and output desired frequency. Crystal oscillator used in this circuit is a 26 MHz clipped sine wave oscillator. Oscillator temperature compensation means that outside temperature changes are internally compensated to provide more stable output frequency over the temperature range. Oscillator has a feature that allows to change the frequency by changing analog input voltage. This input voltage is connected to DAC to provide frequency fine tuning on command.

5.2. Power amplifier

Power amplifier is a very important part of the communication system. It is the part that consumes the most energy in an communication system and sometimes – in the whole satellite.

For the communication system two different amplifiers were tested: TriQuint TQP7M9105 and ST PD84002. Both were chosen because they were available, had enough output power and they work in required ultra high frequency range. Both amplifiers were in an industry standard SOT-89 package. Amplifier used on ESTCube-1 RFMD RFPA0133 was not considered since it had poor availability and sensitivity to mismatched loads.

For both amplifiers similar steps were done. First the amplifier was simulated in linSmith to determine matching network. Then a development board was designed, soldered and measured with network analyser. Finally necessary changes were made in the components to get the performance needed.

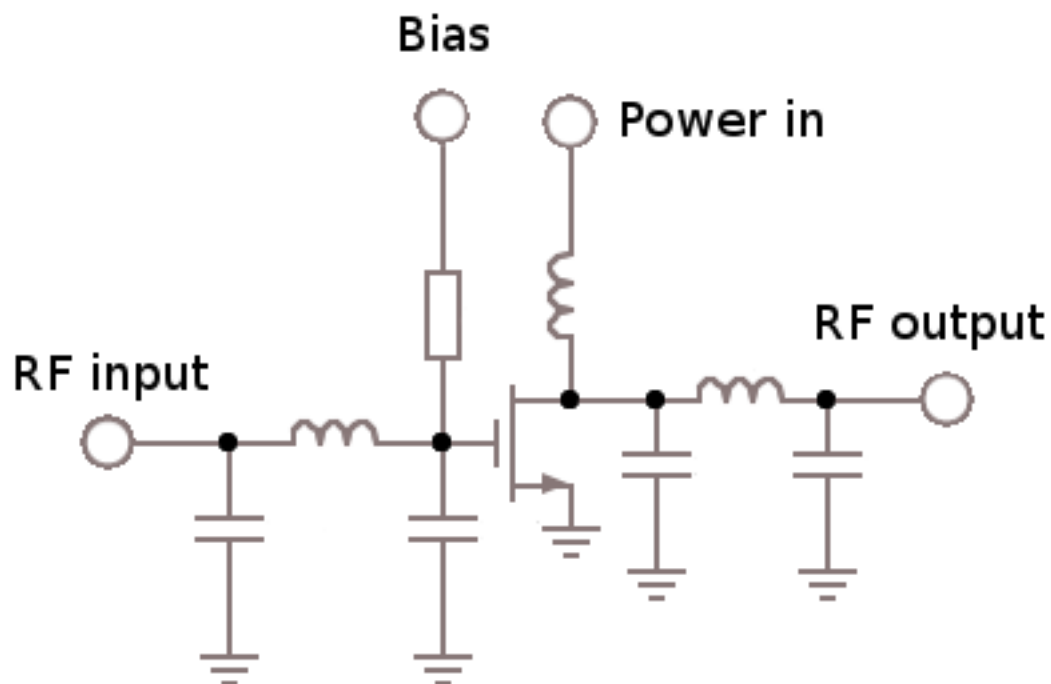

Figure 3: Simplified schematic of the amplifier circuit

Both of these amplifiers were basic FET transistors with some built in circuitry. Most of the

components needed to make a functioning amplifier was external. They both functioned as a class B amplifier with theoretical maximum of 78.5% efficiency. To make class B amplifier several different external part are required as seen in figure 3. Input RF signal has to be AC coupled and matched with amplifier input. Input also has to be DC biased to adjust amplification. Output of the transistor has to be feed with power DC line and RF output has to be AC coupled and matched with next circuit elements.

With RF components matching is important. Component matching means using reactive circuits to match output impedances with next component input impedance. It is important to minimize losses in the system. Typically RF systems, amplifier and antenna complex impedances are matched to match 50 Ω purely resistive system.

First step of the matching is simulating. After testing several programs like Motorola Impedance Matching Program and Agilent Advanced Design Studio, open source program called linSmith was used. Matching with linSmith can be seen on figure 4.

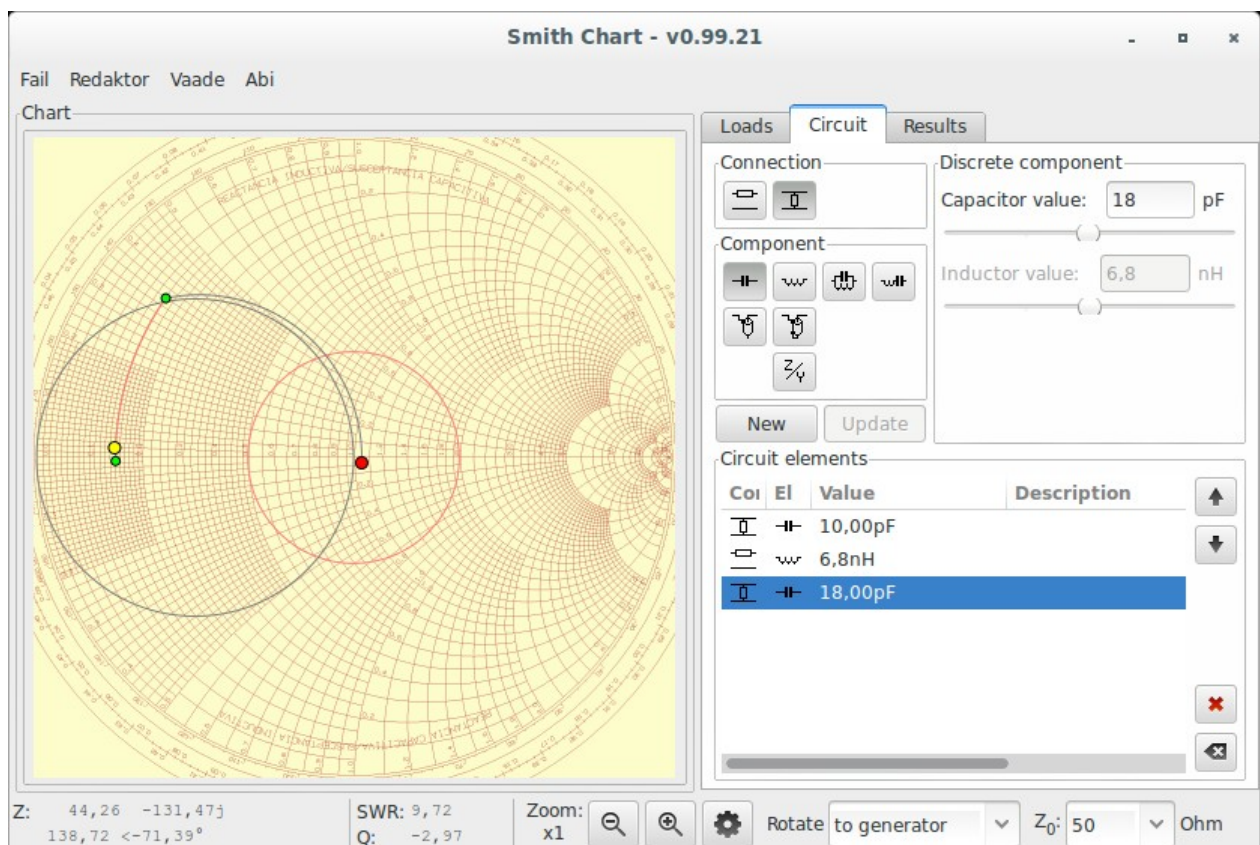

Figure 4: linSmith impedance matching program showing output matching circuit

Complex impedance and usable frequencies must be entered to the loads tab and then the circuit can be described in the circuit tab. For input and output third order pi matching was used consisting of capacitor to the ground, series inductor and second capacitor to the ground. Inductor value was fixed, since inductors are available in less different values. Then capacitor values were changed until input or output matched 50 Ω .

In the left of the window a Smith chart of the circuit can be seen. Smith chart shows complex impedances on a logarithmic polar graph that makes different impedances visually understandable. The centre line on the graph is the real axis with 50 Ω in the very centre. In the left side there is 0 Ω resistance and on the right – open circuit.

LinSmith accepts complex impedance as an input, but both amplifiers provided only scattering parameters (S parameters) in dB and angle format. Python and scikit-rf library were used to convert these values from one representation to another. S parameters were provided for different frequencies and for all combinations of two port amplifier. For input matching S11 parameter was considered and for output matching S22. S11 describes impedance of first port in regard of the first port, S22 second port in regard of the second port.

To convert from S parameters to complex impedance, first the values were saved in a Touchstone SnP Format file. Example for one amplifier was following:

```
# MHz S DB R50
400 -2.73 176.91
```

The script that was used to convert this file to complex impedance was following

```
import skrf as rf
amp = rf.Network('amp.s1p')
print amp.z
```

Complex impedance output from this conversion was used in linSmith to calculate matching networks. After calculating necessary matching components both amplifier boards were built up and measured with network analyser.

DC power was provided according to datasheet values.

Input matching determines how much of the radio power going into the input of the amplifier is actually amplified. It is not critical as long as power amplifier receives enough power. Input

matching was measured in two ways – measuring the change of the gain of the device. Bigger gain means less losses in input matching. Second way the of measuring was to measure complex RF power reflecting back from the input. Power is reflecting back means that input is not matched well and knowing the complex impedance helps to determine necessary components.

Measuring output matching is more complicated than measuring input. Input complex impedance can be measured with network analyser S11 measurement. Measurement gives out information about mismatch and phase shift, that can be used to tweak the matching component values. Measuring output matching of an amplifier can only be done indirectly – by measuring amplification and efficiency of the amplifier. For both amplifiers pi matching network was used and capacitor values were changed to get better efficiency and gain.

Since network analyser used could not provide enough power to drive the input of the power amplifier a signal generator was used to provide constant wave test signal. Output of the amplifier was measured with spectrum analyser to determine gain at centre frequency.

5.2.1. TriQuint TQP7M9105

TriQuint TQP7M9105 is a 1 W high linearity amplifier [23]. This was the first amplifier that we tested. It used 5 V line for DC power. Input impedance matching network was a L network with a series inductor and parallel capacitor.

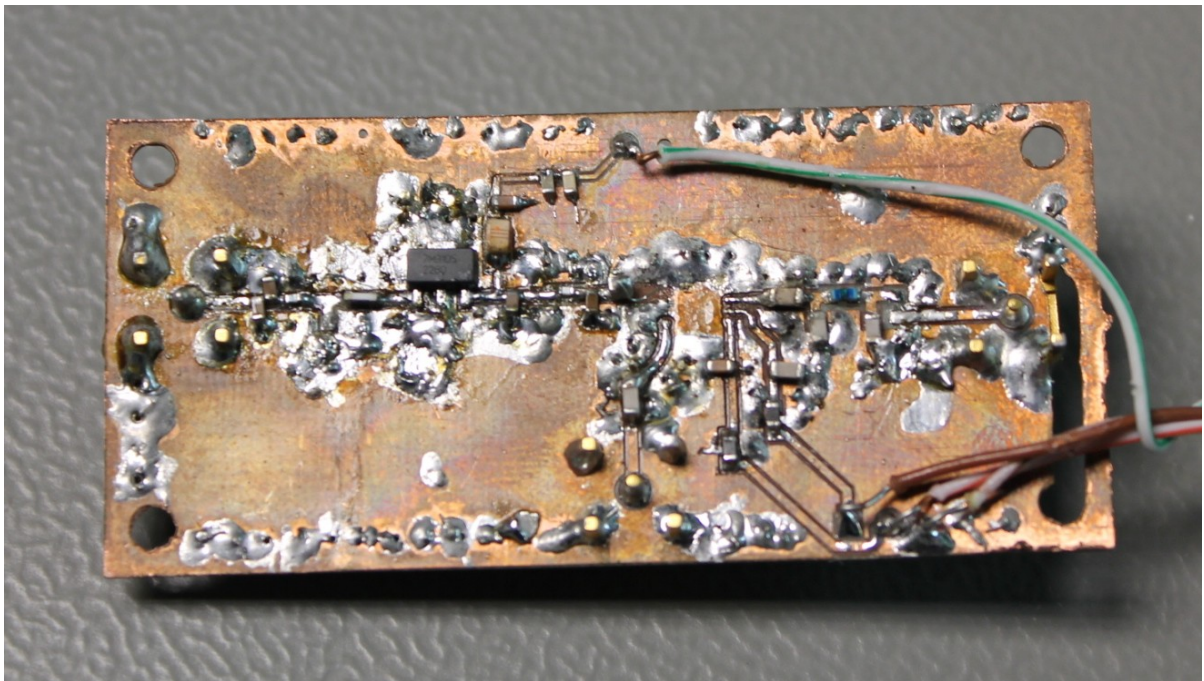

Figure 5: Test board for TQP7M9105 amplifier and antenna switch

Different component values were tried and impedances measured that are provided in table 3.

Inductor value (nH)	Capacitor value (pF)	S11 impedance measured (Ω)
1	0	$4.1 + 8,7i$
3.3	0	$4.4 + 14.5i$
3.3	22	$39 - 17i$
3.3	18	$47.3 + 8,7i$
3.3	19	$50 + 0,8i$

Table 3: Input matching networks tried for TQP7M9105

For output many matching circuit configurations were tested. The best efficiency that was achieved was 29 dBm RF output with 2.5 W DC power draw. Efficiency for these values would be $0.8 \text{ W} / 2.5 \text{ W} = 32 \%$.

It turned out that this amplifier was meant to be high linearity amplifier, used in mobile telephone base stations where efficiency is not a primary concern. Since this amplifier could not be used to build a high efficiency power amplifier, a new amplifier was chosen.

5.2.2. ST PD84002

ST PD84002 was chosen because it provides up to 2 W output power in the necessary frequency range. It also provides good efficiency. Test schematic and setup was very similar to previous tested transistor. This transistor required 8 V power line instead of 5 V like previous. Because 8 V line is available from ESTCube-2 system bus, the communication system does not need any local regulation.

A prototype board was built up to test the amplifier. Prototype board can be seen in figure 6. Inputs and outputs were AC coupled on the board with 100 pF ceramic capacitors. These capacitors have so big capacitance that in ultra high frequency range their series resistance does not affect matching circuits.

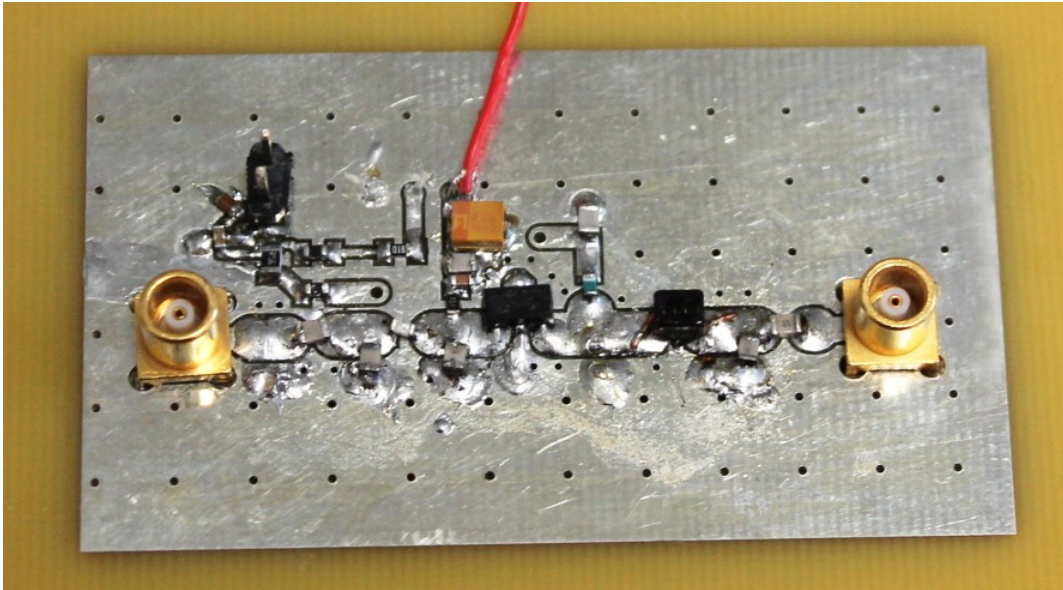

Figure 6: Test board for PD84002 amplifier

Transistor input complex impedance $11.6 - 16.1i \Omega$ was matched with pi matching circuit: a 22 pF capacitor to the ground, series 10 nH inductor and 10 pF capacitor to the ground. Output impedance is $16.0 - 16.1i \Omega$. Different matching components were tested and documented to table 4.

Capacitor value (pF)	Inductor value (nH)	Capacitor value (pF)	Efficiency @ 425 MHz (%)	Efficiency @ 433 MHz (%)	Efficiency @ 440 MHz (%)
2.2	12.5	4.7	55	54	54
0	12.5	4.7	60	57	56
0	17.5	4.7	60	55	54
0	8	4.7	49	50	51
3.3	8	4.7	-	-	40
0	8	6.8			40
0	8	2.2	50	49	50
0	12.5	2.2	42	51	54
0	12.5	6.8	67	68	69

Table 4: Output matching circuit values and measured efficiency of PD84002

The last row of the table was measured with higher input power (17 dBm) that raised the efficiency even more.

5.3. Filters

There are two major RF filters in the system: low-pass antenna filter, band-pass receive input. Filters for radio frequencies are different from regular analog filters – they are built only from reactive components thus do not convert energy to heat. Most similar filters to typical RC filters are lumped filters - RF filters that use inductors and capacitors as circuit elements. Low pass antenna filter is a lumped element filter in this system.

Designing a RF filter requires simulation, measurement in real system and tweaking of the values. Simulation results show filter parameters and required components. Simulations are important to determine component values and performance. Measurements of the built up system can differ from the simulations, because of parasitic elements of the components. At high frequencies component imperfections start to change the behaviour of the circuit. Inductors have measurable resistances and capacitances. Capacitors have series inductances etc. The layout on the circuit board can be important – inductors can couple with each other and ground planes increase component capacitance.

4.3.1. Low-pass antenna filter

Between antenna switch and antenna connector there is an antenna filter. This is a low-pass filter, which has to suppress spurious emissions generated by components on the signal path – transceiver, power amplifier and antenna switch [9]. Low-pass filter has to have low insertion loss, since it is in the high power path.

Third order PI filter was chosen as this filter, it has one inductor in series with signal line and two capacitors with equal values between signal and ground. Coilcraft A05T_L_ 18.5 nH inductor was chosen because its high Q and same size as inductor used in PA output matching.

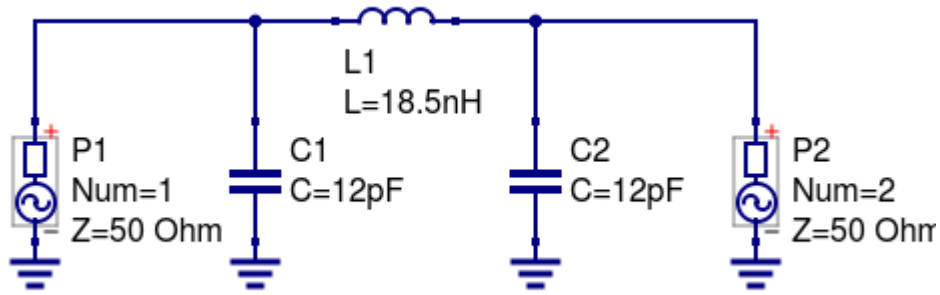

S parameter simulation

Equation

Eqn1
 $\text{dBS21}=\text{dB}(\text{S}[2,1])$

SP1
 Type=log
 Start=200MHz
 Stop=600MHz

Figure 7: Filter schematic in QUCS

Capacitor values were calculated using Quite Universal Circuit Simulator (QUCS) scattering parameter simulation. Insertion loss graph was simulated to determine filter cutoff frequency, and thus select capacitor values. Simulation is shown on figure 7 and the result in figure 8. The simulation showed that schematic needs two 12 pF capacitors to form a low-pass filter with -1 dB cutoff frequency of 470 MHz.

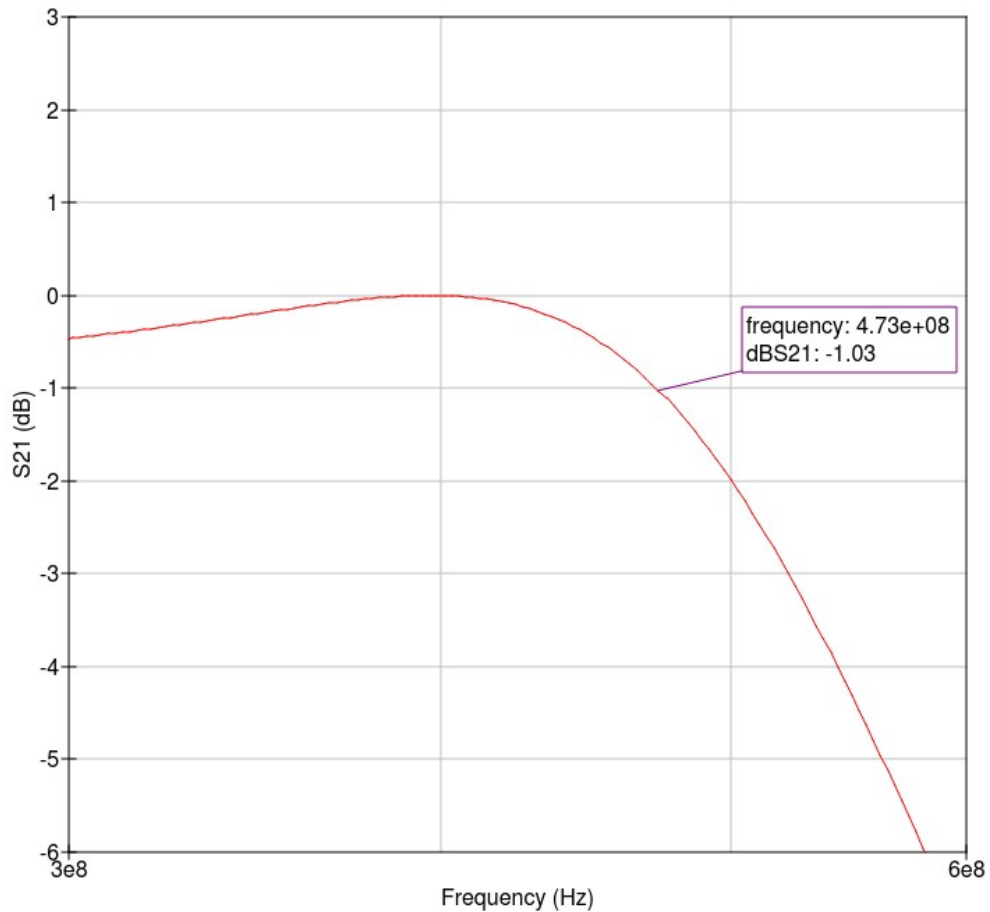

Figure 8: Simulated insertion loss to frequency graph with -1 dB cutoff frequency label

Because of circuit board capacitance and component parasitic elements the real measured values will differ from the simulated. To determine capacitor values that would be used in the real system the filter was measured in the final circuit. Filter insertion losses were measured with network analyser using antenna connector as one port and soldered coaxial cable as other. Network analyser was configured to measure S12 – insertion loss.

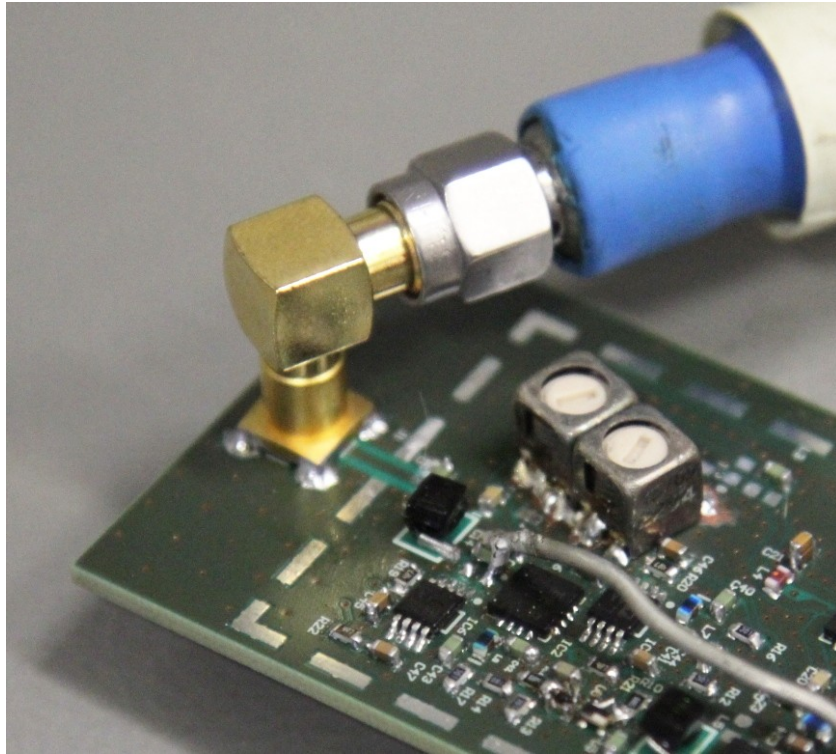

Figure 9: Test setup to measure filter in real system

Measurements showed that with simulated 12 pF capacitors the cutoff frequency was too low, only 407 MHz. Decreasing the capacitance increased filter cutoff frequency. Final capacitor value was 8.2 pF that provided acceptable insertion losses and cutoff frequency.

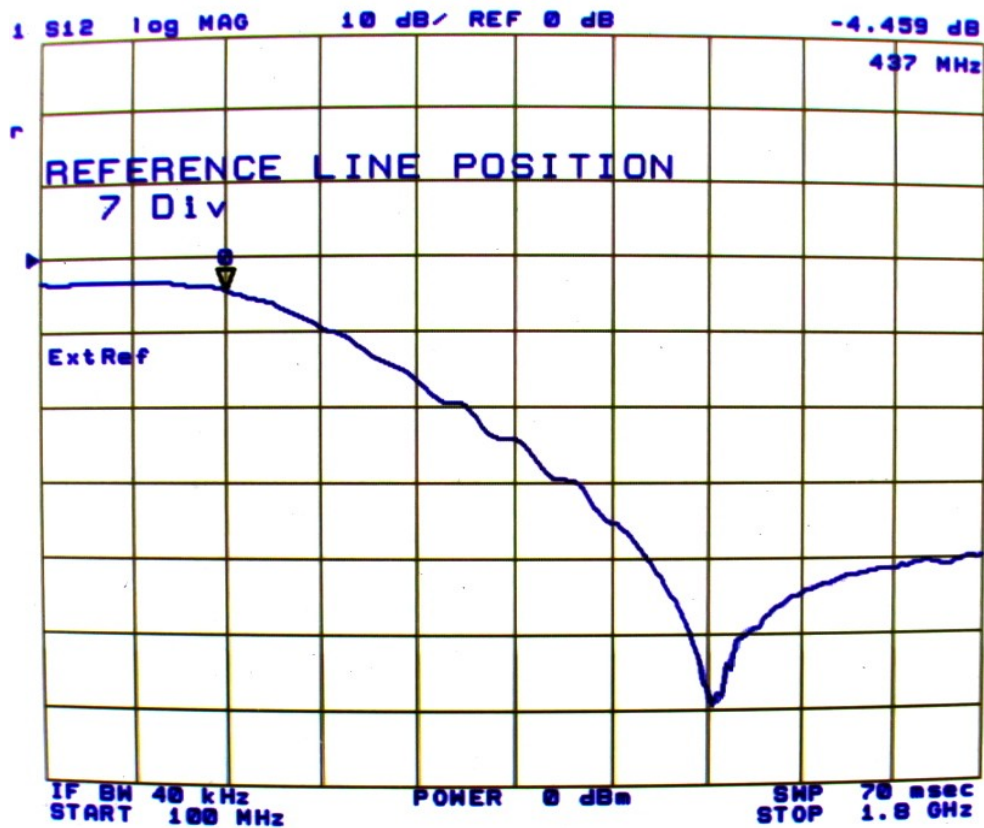

Figure 10: Measured low-pass filter insertion loss graph with marker at cutoff frequency

Insertion loss was measured with network analyser from 300 MHz to 600 MHz with grid step of 1 dB. The graph on figure 10 shows that -1 dB cutoff frequency is 460 MHz. Insertion loss in required passband is less than 0.5 dB.

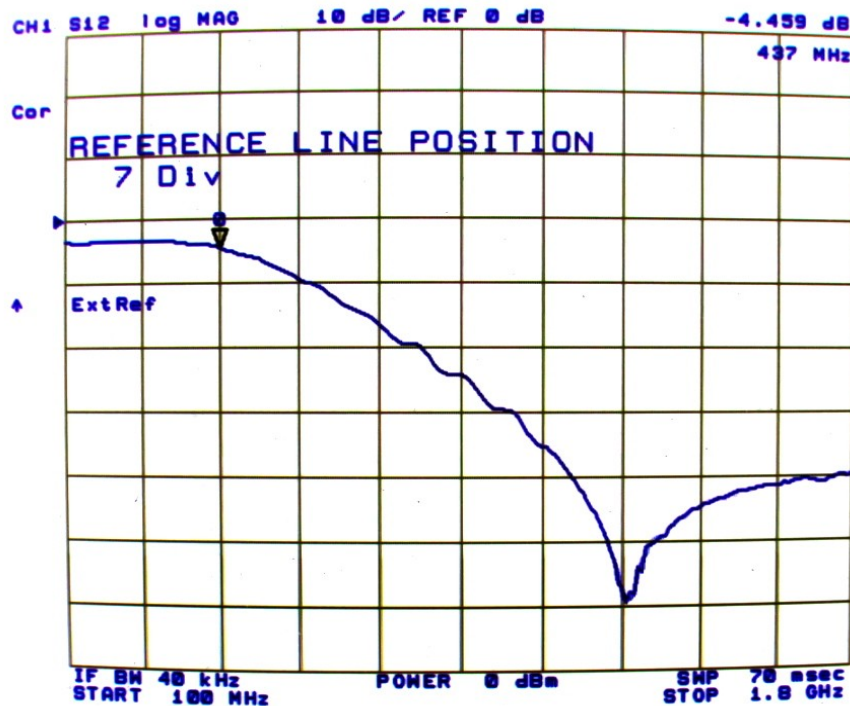

Figure 11: Measurement of the low pass filter in 100 MHz to 1.8 GHz frequency range

Measurement of the low-pass filter in the wider frequency range is shown in figure 11. Attenuation at first harmonic (874 MHz) is 20 dB and at second harmonic (1.3 GHz) is 60 dB. Attenuation begins to rise a little after 1.3 GHz because the filter is not ideal and has parasitic components.

5.3.2. Receive input filter

To provide good selection and noise rejection for receiver there is a helical filter on the input signal path[10]. Helical filter is a band-pass filter that attenuates signals not in the necessary passband to minimize effect of strong signals on other frequencies. Helical filter was used because of its high Q factor and ability to tune frequency[11]. Other filters that were considered were not available for required frequency range or had much lower Q factor.

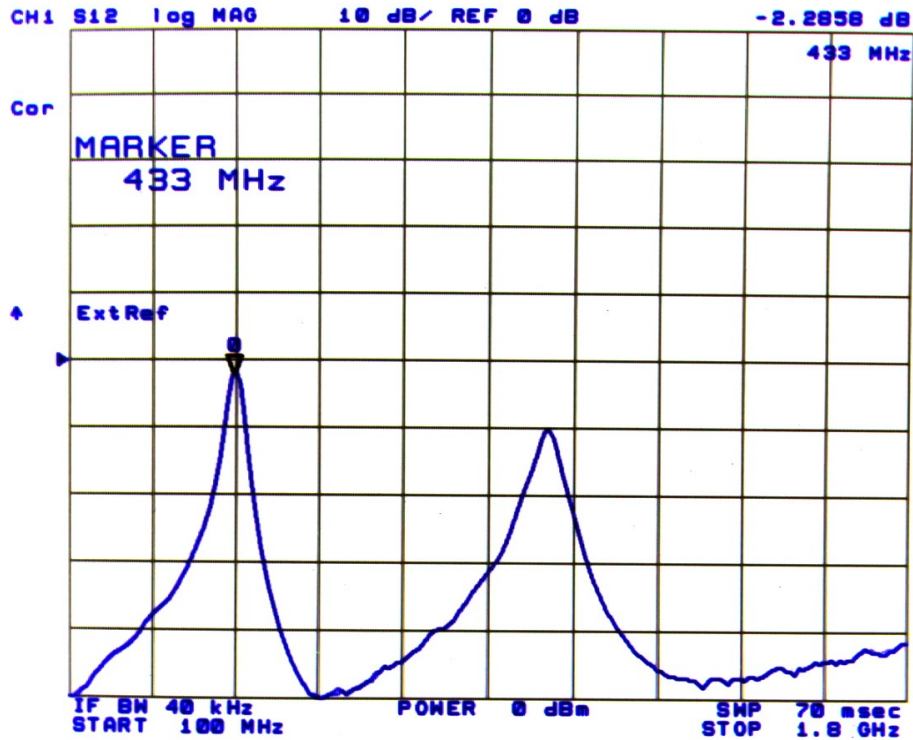

Figure 12: Attenuation graph of helical filter in the 100 MHz to 1.8 GHz frequency range

Helical filter available with closest passband was 460 MHz centre frequency TOKO Double tuned 492S-1060A. It has 10 dB of bandwidth (-1 dB) and maximum of 3.5 dB of insertion loss at centre frequency. Filter was soldered to a prototyping board and insertion loss over desired frequency range was measured with spectrum analyser. Two tuning screws were adjusted to lower its centre frequency to 437 MHz. The resulting attenuation graph can be seen on figure 12.

5.4. Circuit board layout

To provide maximum radio frequency power transfer between components all RF components and printed circuit board (PCB) tracks between them have to be impedance matched [10]. Matching components to 50 Ω impedance is done using LC networks next to each corresponding pin.

To match circuit board tracks to 50 ohms the width and distance from ground plane had to be controlled. PCB was manufactured by Brandner and their stack-up is described in table 5. Copper thickness is 53 μm . Dielectric thickness between top layer and inner layer is 0.42 mm. The dielectric constant for this material is 4.5 [24].

Layer	Name of layer	Type	Layer thickness (mm)
1	External copper	18 μm + GalvCu 35 μm	0.053
	Prepreg	2116 (0,11mm)	0.110
	Etched innerlayer	FR4 VK 0.2 (0.2mm)	0.200
	Prepreg	2116 (0,11mm)	0.110
2	Innerlayer foil	35 μm	0.035
	Innerlayer	High Tg 0,51mm 35 μm /35 μm	0.510
3	Innerlayer foil	35 μm	0.035
	Prepreg	2116 (0,11mm)	0.110
	Etched innerlayer	FR4 VK 0.2 (0.2mm)	0.200
	Prepreg	2116 (0,11mm)	0.110
4	External copper	18 μm + GalvCu 35 μm	0.053
	Material thickness (mm)		1.526 \pm 10%

Table 5: Communication board PCB stack-up

Eeweb microstrip impedance calculator (<http://www.eeweb.com/toolbox/microstrip-impedance>) was used to calculate necessary track width for 50 ohm track impedance. Calculation showed 0.7 mm track width that was used for all RF tracks.

During circuit layout care was taken with inductor layout. Ground plane was cleared below inductors to reduce parasitic capacitance and sensitive inductors were placed at 90 degrees offset to minimize crosstalk[12].

All of the RF circuitry is screened with surface mount tinned steel shield. The shield protects receive circuitry from electromagnetic interference from other satellite subsystems and protects other subsystems from high frequency emissions from transmitter.

Circuit and schematic were laid out by Ahti Laurisson under the supervision and guidance of work author.

6. Tests

As discussed in previous chapter all of the components were individually tested and characterised. These components were designed to a one complete electrical model. This board is designed to be electrically similar to final flight board. All of the components were designed in to system to test out the integration of the whole system. Only part electrically different was that there were no RS-485 transceivers, since main bus communication part for ESTCube-2 was not yet developed.

The schematic is included in appendix 2, board layout in appendix 3, photograph of the soldered board is in figure 13.

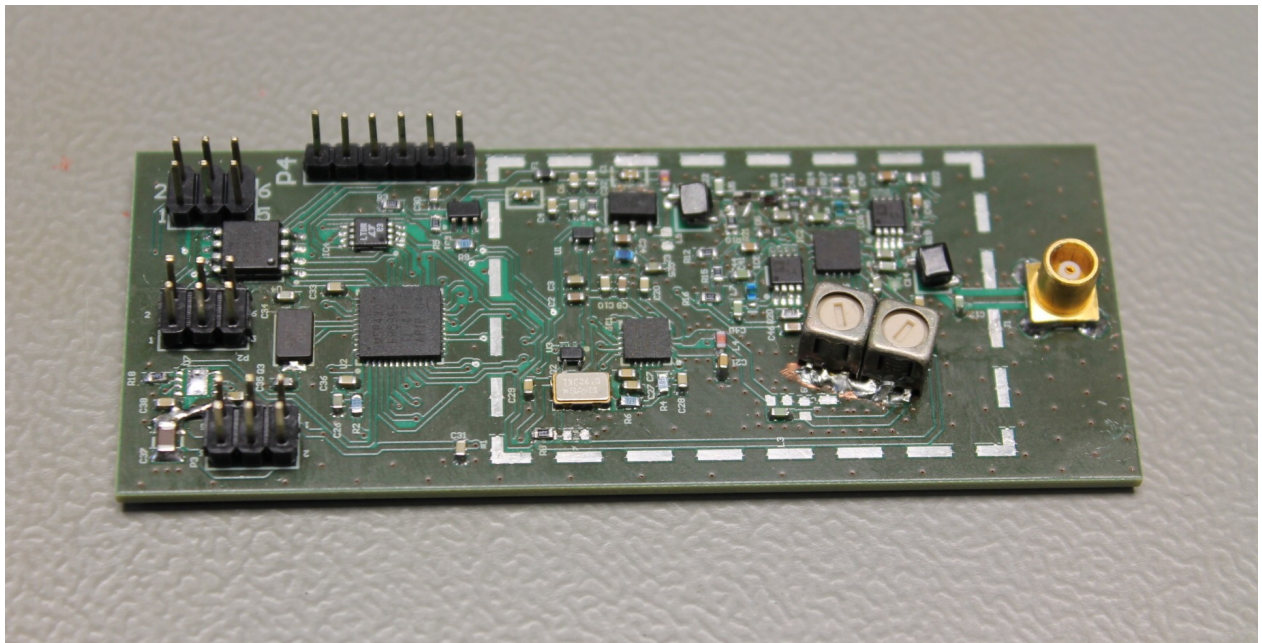

Figure 13: First integrated prototype of the communication system

Soldered board has passed first tests. All components have powered up successfully and RF filters have been measured. Communication between microcontroller, DAC and transceiver have been tested in lab conditions. Full RF tests are planned as a further work in summer of 2015.

7. Summary

Communication is one of the most important parts of any satellite. Estonian future satellite ESTCube-2 needs a new and advanced communication system to upload commands and firmware and download telemetry and images.

The goal of this masters thesis was to determine system architecture and develop first electrical prototype of this communication system. Strengths and weaknesses of previous systems was researched and new system design was determined. Necessary single components were determined. Single components were built to prototypes, tested and characterised. RF parameters of filters were measured and found to be suitable for the system. Components were integrated to a first electrical model of the communication system. All of the work meets the requirements set to the system. Since power is very limited on small satellites focus was making the communication system energy efficient.

This work could not be done without support from people in ESTCube team. Most of the necessary knowledge was taught by supervisors. Much of supporting work was done by other members of communication subsystem team – Ahti Laurisson, Taavi Adamson and Laur Joost.

Work on the system continues in to develop full software and test all the component integration.

This work contains technical drawings and description of developed system. It also provides information for developing other similar systems.

8. References

1. “CubeSat Design Specification” (2014) The CubeSat Program
http://www.cubesat.org/images/developers/cds_rev13_final2.pdf Used 2015-05-14
2. “Announcement of CubeSat launch initiative” (2014) The National Aeronautics and Space Administration
[http://www.nasa.gov/sites/default/files/files/cubesat_launch_initiative_announcement_2014_final\(1\).pdf](http://www.nasa.gov/sites/default/files/files/cubesat_launch_initiative_announcement_2014_final(1).pdf) Used 2015-05-14
3. Mike Safyan “Overview of the Planet Labs Constellation of Earth Imaging Satellites” (2015) <http://www.itu.int/en/ITU-R/space/workshops/2015-prague-small-sat/Presentations/Planet-Labs-Safyan.pdf> Used 2015-05-14
4. “ESTCube-1 nanosatellite for electric solar wind sail in-orbit technology demonstration” (2014) Proceedings of the Estonian Academy of Sciences
5. “Analysis of the electrical power system for ESTCube-1” (2013) Proceedings of 64th International Astronautical Congress
6. “Spectrum Requirements for the Amateur and Amateur-satellite Services” (2014) International Amateur Radio Union
http://www.iaru.org/uploads/1/3/0/7/13073366/spectrum_requirements_rev2_nov_2014.pdf Used 2015-01-31
7. “ESTCube-1 radio details” <http://www.estcube.eu/en/radio-details> Used 2015-05-15
8. “MSP430FR59xx Mixed-Signal Microcontrollers ” (2014) Texas Instruments
<http://www.ti.com/lit/ds/symlink/msp430fr5969.pdf> Used 2015-01-20
9. Norman Dye , Helge Granberg (2001) “Radio Frequency Transistors”, pp 168
10. Joseph J. Carr (2002) “RF Components and Circuits”, pp 285, 52
11. C. J. Kikkert (2004-2009). “RF Electronics”, pp 191
12. “Application Note 1200.04 RF Design Guidelines: PCB Layout and Circuit Optimization” (2006) Semtech
http://www.semtech.com/images/datasheet/rf_design_guidelines_semtech.pdf Used 2015-

01-23

13. "SGL0363Z 5MHz to 2000MHz low noise amplifier silicon germanium" (2006) RF Micro Devices
http://www.rfmd.com/store/downloads/dl/file/id/28126/sgl0363z_data_sheet.pdf Used 2015-05-15
14. "NanoCom AX100 Datasheet" (2015) GomSpace ApS
<http://www.gomspace.com/documents/gs-ds-nanocom-ax100-1.5.pdf> Used 2015-05-15
15. "NanoCom U482C Datasheet v5.0" (2015) GomSpace ApS
<http://www.gomspace.com/documents/GS-DS-U482C-5.0.pdf> Used 2015-05-15
16. "UTRX Half Duplex UHF Transceiver" http://www.clyde-space.com/cubesat_shop/communication_systems/350_utrx-half-duplex-uhf-transceiver
Used 2015-05-15
17. "TRXUV VHF/UHF Transceiver" Innovative Solutions In Space
http://www.isispace.nl/brochures/ISIS_TRXUV_Transceiver_Brochure_v.12.5.pdf Used 2015-05-15
18. Toomas Vahter "Tudengisatelliit ESTCube-1" (2010)
http://www.lr.ttu.ee/eriala/2010sygis/Eriala_1102.pdf Used 2015-05-15
19. Carlos Jorge Rodrigues Capela "Protocol of communications for VORSat satellite - link budget" <http://paginas.fe.up.pt/~ee97054/Link%20Budget.pdf> Used 2015-05-16
20. "Link Budget Analysis: Digital Modulation, Part 2" (2013) Atlanta RF
www.atlantarf.com/FSK_Modulation.php Used 2015-05-16
21. "Si4464/63/61/60 high-performance, low-current transceiver" (2012) Silicon Laboratories
<https://www.silabs.com/Support%20Documents/TechnicalDocs/Si4464-63-61-60.pdf>
Used 2015-05-17
22. "TQP4M0010 High Isolation Absorptive SPDT Switch" (2013) TriQuint
<http://www.triquint.com/products/d/DOC-B-00000236> Used 2015-05-17
23. "TQP7M9105 1W High Linearity Amplifier" (2014) TriQuint
<http://www.triquint.com/products/d/doc-b-00000072> Used 2015-05-18

24. "High Reliability Glass Epoxy Multi-layer Materials (High Tg & Low CTE type)" (2011)
Panasonic
https://www3.panasonic.biz/em/pcb/en/product/r1755v/2_data_sheet/10100721_HIPER-V_R-1755V_R-1650V_2011_07_05.pdf Used 2015-05-18

9. Kokkuvõte

UHF-sagedusala sidesüsteem kuupsatelliidile

Side maaga on iga satelliidi üks kõige tähtsamatest osadest. Eesti tulevane satelliit ESTCube-2 vajab sidesüsteemi käskude ja info kahepidiseks vahetamiseks.

Selle magistritöö eesmärgiks oli panna paika süsteemi arhitektuur ja valmistada esimene prototüüp. Töö alguses uuriti erinevaid olemasolevaid ja varem valmistatud lahendusi. Eelmise sidesüsteemi ja uurimise järgi pandi paika uue süsteemi ülesehitus. Kõik üksikkomponendid valiti välja. Tähtsamad komponentidest ehitati prototüübid, mida seejärel mõõdeti ja iseloomustati. Filtrite komponentid testiti reaalse plaadi peal järgi ja mõõdeti kõik olulised raadio parameetrid. Komponentidest pandi kokku esimene elektriliselt lõplik sidesüsteemi mudel, millega tehti ka esimesed testid. Kõikide lõplike komponentide mõõtmised näitasid, et need sobivad süsteemile seatud nõuetega kokku ja suudavad neid täita. Kuna miniatuursete satelliitide peal on energia kogus piiratud oli fookus võimalikult energiaefektiivse süsteemi valmistamisel.

Töö süsteemiga jätkub. Ees ootab lõpliku tarkvara arendus ja terviksüsteemi põhjalik testimine erinevates keskkondades.

Selles töös on arendatud süsteemi kogu dokumentatsioon – võrdlustabelid, tehnilised joonised ja selgitused. Töö sisaldab ka informatsiooni teiste sarnaste süsteemide arendamiseks.

Appendix 1 – Comparison of communication systems

Model	Manufacturer	Modulation	Data rate (bps)	Output power (dBm)	Input sensitivity (dBm)	Communication protocols	Transmit efficiency	Receive power (mW)	Dimensions
NanoCom AX100 [14]	GomSpace	FSK/MSK	1000 - 115200	30	-137	I2C, CAN, UART	38% ¹	-	65 mm x 40 mm x 6.5 mm
NanoCom U482C [15]	GomSpace	FSK/MSK, OOK	1200 - 9600	27 - 33	-123	I2C	40% ¹	230 ¹	95 mm x 90 mm x 18 mm
UTRX [16]	Clyde Space	FSK	1200, 9600	27 - 33	-120	I2C, UART	20% ¹	< 250	96 mm x 90 mm
Full Duplex Transceiver [17]	ISIS	BPSK, OOK	1200 - 9600	22	-104	I2C	10% ¹	< 200	96 mm x 90 mm x 15 mm
Communication system [18]	ESTCube-1	FSK/OOK	1200, 9600	20, 27	-	UART	25% ¹	165	96 mm x 90 mm

1. Calculated from power usage and output RF power.

Appendix 2 – Electrical schematic

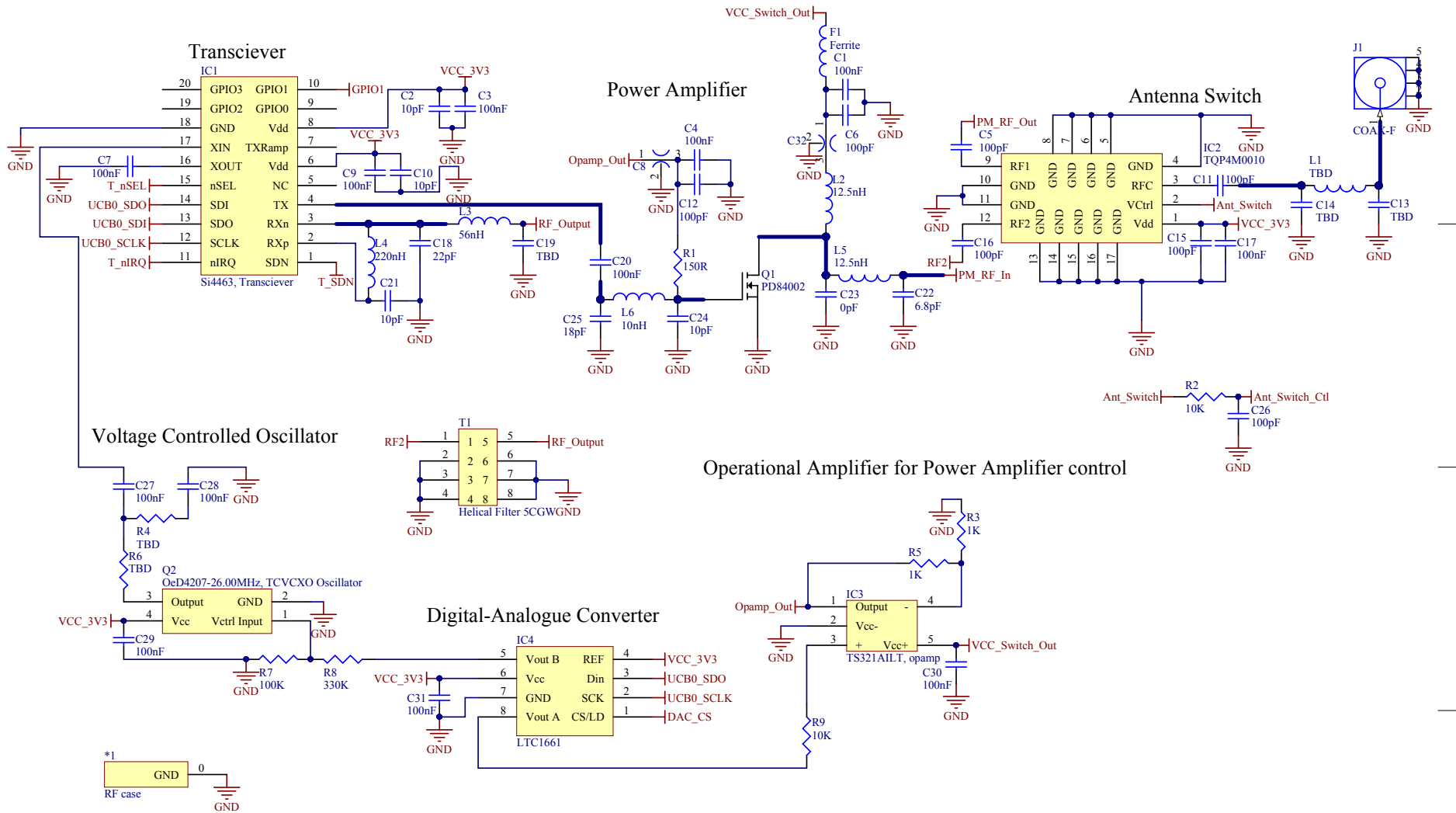

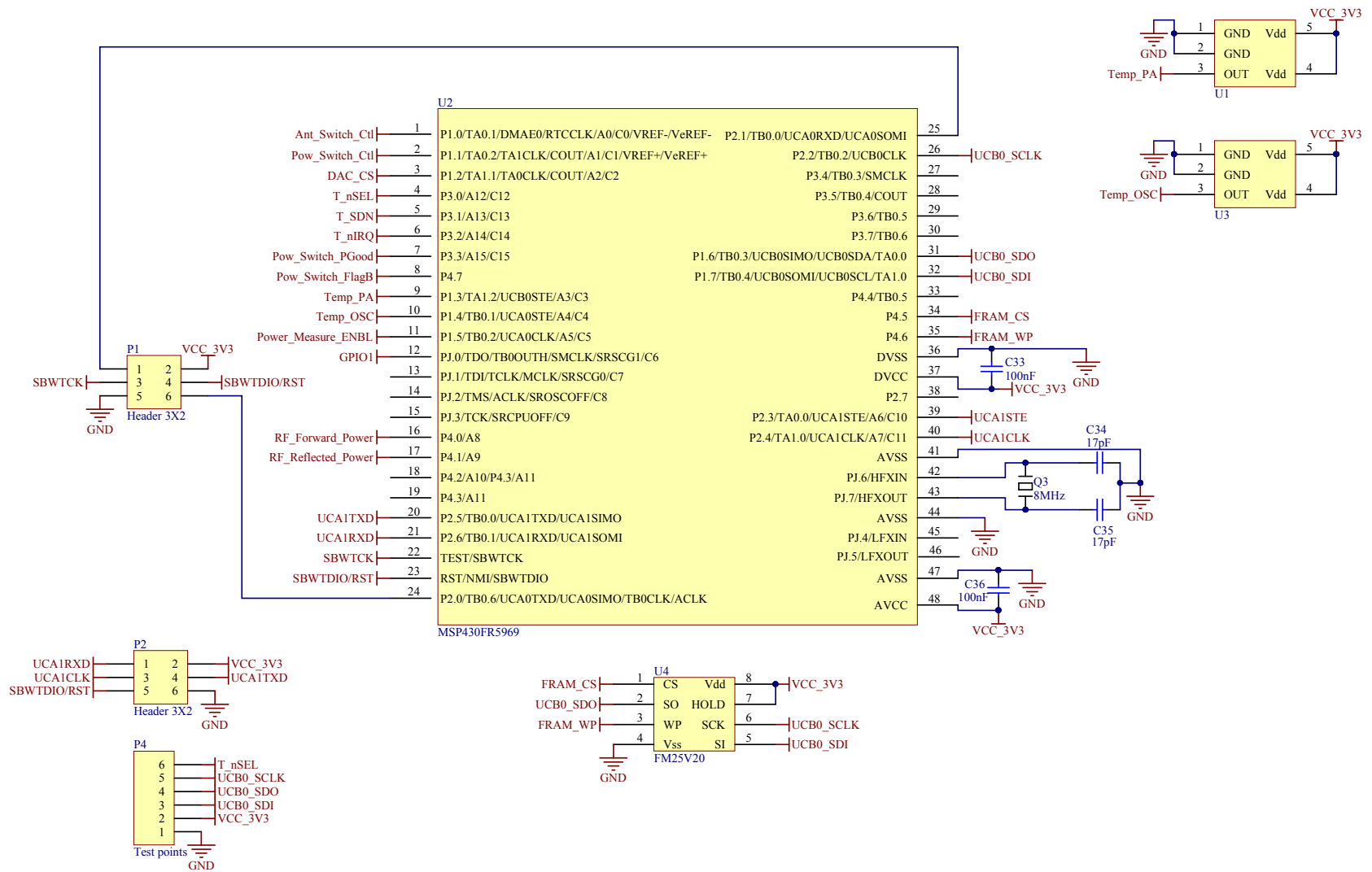

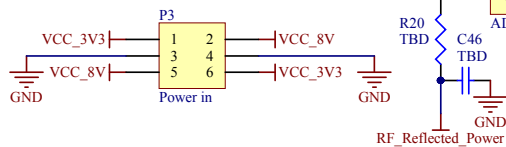
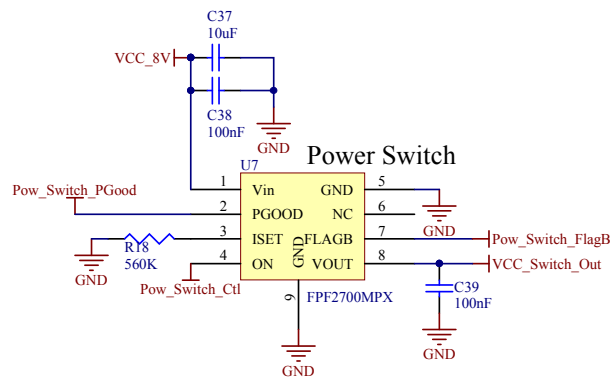

Power Measurement

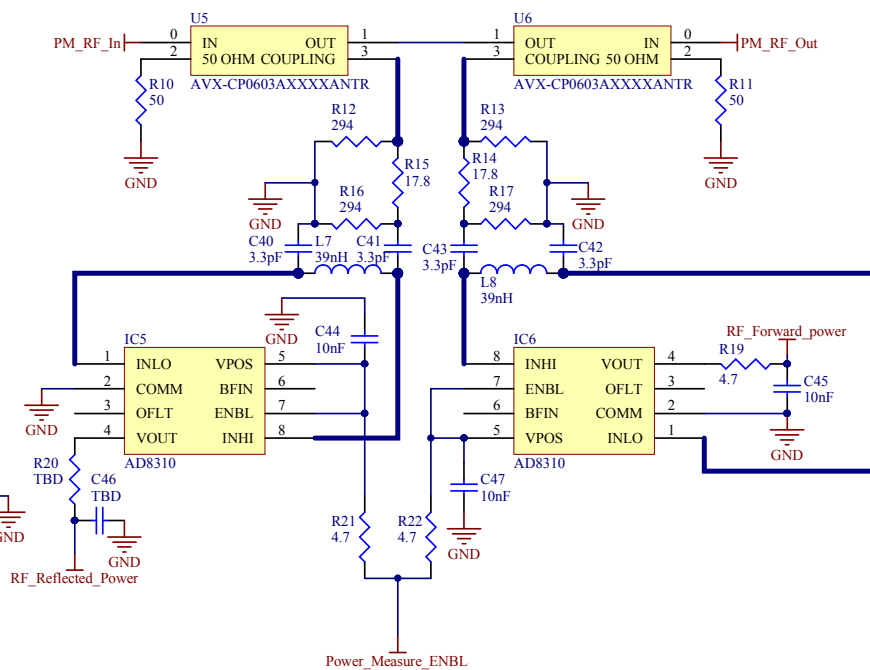

Appendix 3 – Board layout

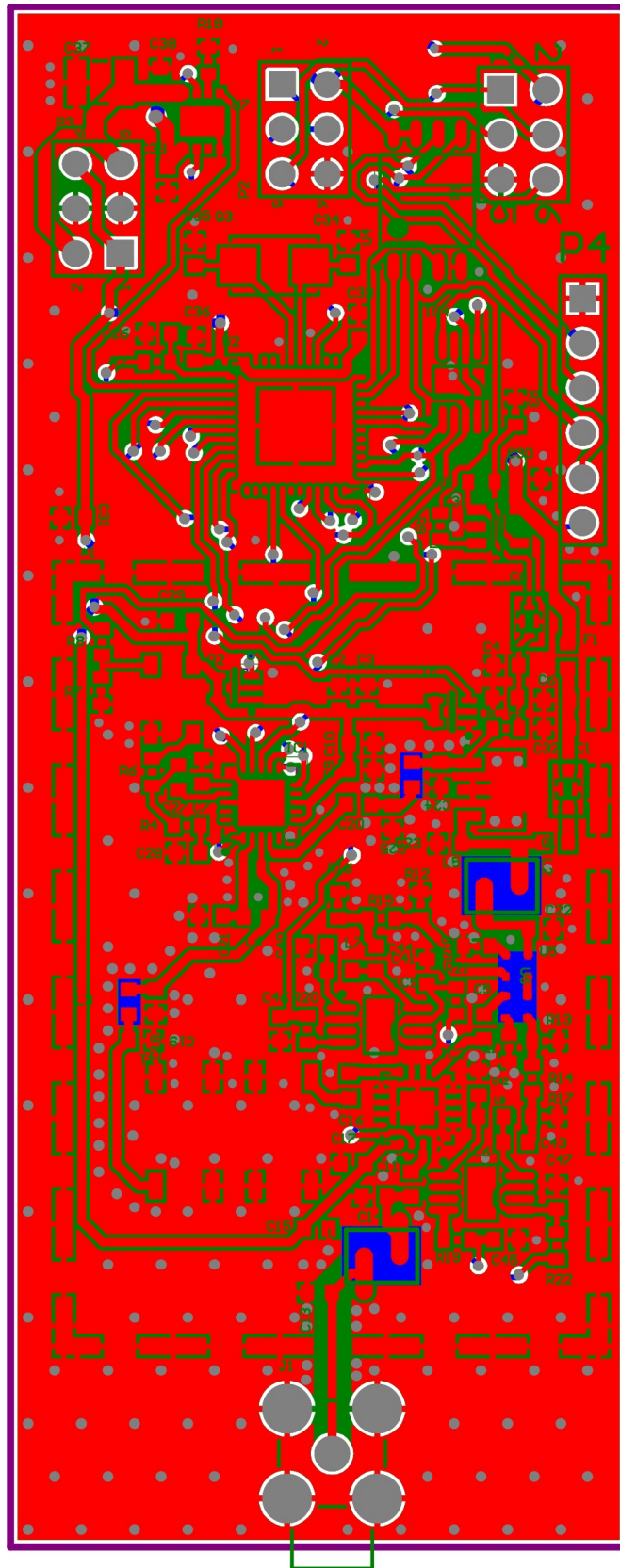

Non-exclusive licence to reproduce thesis and make thesis public

I, Jaanus Kalde

1. herewith grant the University of Tartu a free permit (non-exclusive licence) to:
 - 1.1. reproduce, for the purpose of preservation and making available to the public, including for addition to the DSpace digital archives until expiry of the term of validity of the copyright, and
 - 1.2. make available to the public via the web environment of the University of Tartu, including via the DSpace digital archives until expiry of the term of validity of the copyright,

UHF COMMUNICATION SYSTEM FOR CUBESATELLITE,

supervised by Viljo Allik,

2. I am aware of the fact that the author retains these rights.
3. I certify that granting the non-exclusive licence does not infringe the intellectual property rights or rights arising from the Personal Data Protection Act.

Tartu, 15.05.2015