

Circular polarised antenna fabricated with low-cost 3D and inkjet printing equipment

S. Jun, B. Sanz-Izquierdo, J. Heirons, C. X. Mao, S. Gao, D. Bird, A. McClelland

The fabrication of a patch antenna using low-cost 3D printing equipment is presented. A circular polarised (CP) patch antenna is manufactured by combining inkjet printing and stereolithography (SLA) technology. The substrate has been fabricated by curing photosensitive resin while the patch element of the antenna has been inkjet printed using silver ink. The printed antenna satisfies the required reflection coefficient, axial ratio and radiation pattern at 1575 MHz. The aim is to demonstrate an inexpensive technology that could be used for the fabrication of antennas on customised 3D printed substrates. The performance of the antenna is summarised through simulations and experimental results.

Introduction: Metal etching and subtractive processes are the most common methods employed for the fabrication of antennas and microwave devices. Recently, there has been an increasing research interest in applying additive manufacturing (AM) [1] - [7] for electronic device prototyping and fabrication. AM offers design freedom, customisation, and potential cost reduction for low volume production processes. Several microwave structures have been reported, including frequency selective surfaces (FSS) [1], electromagnetic band gap structures (EBGs) [2], waveguide components [3] and antennas [4]. A variety of technologies and materials are available for the layer by layer fabrication of dielectric and metals. Two of the most accessible and lowest cost techniques for the printing of dielectrics are fuse deposition modelling (FDM) and stereolithography (SLA). EM structures have been fabricated by adding metallic layers over FDM substrates [2], [5]. In [2], the metallic layer was added by hand, while in [5] a dispenser was used to add layers of silver conductive paste. One of the problems of FDM substrates is the roughness of the external surfaces which limits the metallic layers to thicker, paste based metallic materials. SLA substrates, on the other hand, provide smoother surfaces which can be an advantage when fabricating with other metallic layer deposition processes such as inkjet printing. Inkjet printing has been demonstrated for the fabrication of antennas on various substrates such as paper [6] and textiles [7].

This letter describes the use of inkjet printing technology for the fabrication of a patch antenna on a 3D printed substrate. A circularly polarised (CP) patch antenna has been fabricated using a combination of stereolithography and inkjet printing technology, both of which methods have used inexpensive machines. As CP patch antennas are created by slightly modifying the shapes of the radiators, they are particularly suitable for the assessment of the fabrication process. Circularly polarised antennas have applications in satellite communications technologies such as the Global Positioning System (GPS). CST Microwave Studio™ has been used for the antenna design and simulations. The goal of this work is to demonstrate a simple and low cost fabrication method which can be used for prototyping, and custom antenna development.

CP antenna design and performance: A photograph and a cross section view of the circularly polarized (CP) patch antenna are shown in Fig 1. The dimensions are given in Table 1. The rectangular patch radiator was positioned on a square substrate with side of 100mm and thickness of 3 mm. The feed was located on the x and y axis with distances of f_x and f_y from the edge of the patch. The substrate was fabricated using the SLA Form1+ printer [8] and clear (translucent) resin. The UV cured resin had a dielectric constant of 2.83 and loss tangent of 0.038, which was measured through a transmission line system. The measured surface roughness of the SLA substrate was 206 nm. After the SLA printing of the substrate, an Argentum's Cartesian Co. printer [9] was used to add the metallic layers of the patch radiator. The printer uses a two-stage process where silver nitrate and an ascorbic acid (Vitamin C) solution are deposited. The measured electrical resistivity was less than $3 \times 10^{-7} \Omega\text{-m}$ when 25 layers were printed. The surface roughness

increased to 7183nm. A square brass ground plane was positioned on the backside of the substrate. A 50Ω SMA connector was attached to the ground plane using standard soldering, and to the top patch using silver epoxy glue.

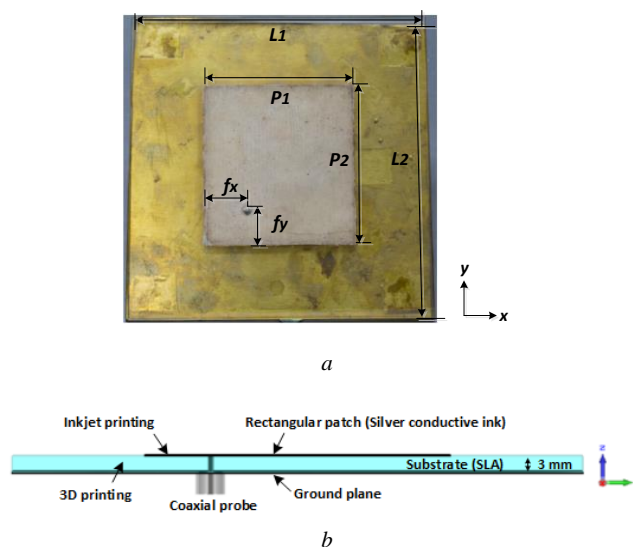

Fig. 1 Circularly polarised patch antenna geometry

a Photograph with dimensions

b Cross-sectional view

Table 1

	L_1	L_2	P_1	P_2	f_x	f_y
Dimensions (mm)	100	100	50.36	53.64	14.66	11.60

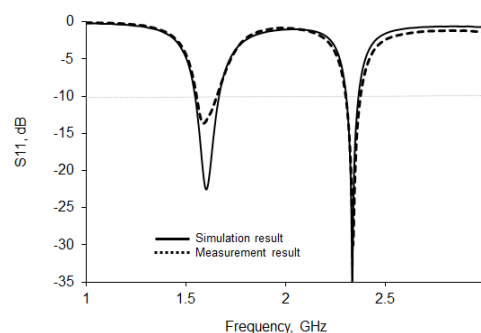

Fig. 2 Reflection coefficient of CP patch antenna

The simulated and measured reflection coefficients (S_{11}) are presented in Fig. 2. The computed and experimental results compared very well. There is a first resonance at 1575MHz with -10dB bandwidth from 1550 to 1650 MHz. A second resonance can also be found at about 2.3 GHz with bandwidth of 3%. The axial ratio of the circularly polarised antenna at 1575 MHz is shown in Fig. 3. Good circular polarisation is found with 3 dB axial ratio from 1570 to 1600 MHz. Fig. 4 presents the simulated and measured far-field radiation patterns in the xz and yz plane at 1575MHz. The shapes of the measured radiation patterns are almost identical to that of simulations. A maximum gain of 3.2 dB was obtained in the measurements.

Conclusions: The fabrication of a circularly polarised patch antenna with inexpensive 3D printed equipment has been demonstrated. Stereolithography (SLA) techniques can produce substrates with surfaces sufficiently smooth to be suitable for printing conductive layers with inkjet printing processes. Inkjet printing of metallic layers can be achieved using the Cartesian Co. [8] or similar equipment. This machine uses a combination of ascorbic acid and silver nitrate. Good performance in terms of impedance matching, axial ratio and radiation patterns has been achieved. The circularly polarised antenna resonates at the 1575 MHz band used for GPS systems. The advantage of the

proposed fabrication method over previously reported work is the use of low cost machines which are more suitable for home and office use. A potential future development could be the modification of substrates to enhance antenna performance.

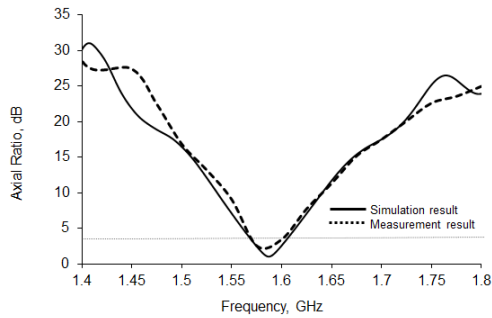

Fig. 3 Measured and Simulated axial ratio of CP patch antenna

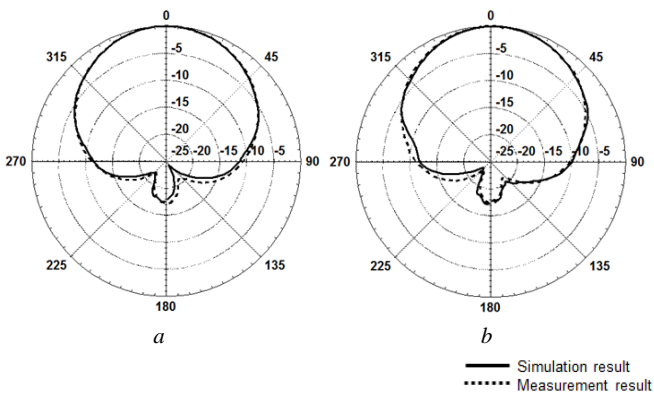

Fig. 4 Measured and simulated radiation patterns at 1575 MHz

a xz- plane

b yz- plane

Acknowledgments: The authors would like to thank S. Jakes, L. Winchester and A. Elibiary for assisting in the fabrication and testing of the antenna. This work was supported by the UK Royal Society and the EPSRC High Value Manufacture Catapult Fellowship scheme.

S. Jun, B. Sanz-Izquierdo, J. Heirons, C. X. Mao, S. Gao (School of Engineering and Digital Arts, University of Kent, Canterbury, Kent CT2 7NT, UK.)

D. Bird, A. McClelland (The Centre for Process Innovation, Thomas Wright Way, NETPark, Sedgefield, Co Durham, TS21 3FG)

E-mail: b.sanz@kent.ac.uk

References

- 1 Sanz-Izquierdo, B., and Parker, E.A.: '3-D Printing of Elements in Frequency Selective Arrays', *IEEE Trans. Antennas Propag.*, 2014, **62**, (12), pp. 6060-6066
- 2 Jun, S., Sanz-Izquierdo, B., and Parker, E.A.: '3D printing technique for the development of non-planar electromagnetic bandgap structures for antenna applications', *Electron. Lett.*, 2016, **52**, (3), pp. 175-176
- 3 D'Auria, M., Otter, W.J., Hazell, J., Gillatt, B., Long-Collins, C., Ridler, N., and Lucyszyn, S.: '3-D printed metal-pipe rectangular waveguides', *Trans. Compon. Packag. Manuf. Technol.*, 2015, **5**, (9), pp. 1339-1349
- 4 Nayeri, P., Liang, M., Sabory-Garcia, R.A., Tuo, M., Yang, F., Gehm, M., Xin, H., and Elsherbeni, A.Z.: '3D printed dielectric reflectarrays: low-cost high-gain antennas at sub-millimeter waves', *IEEE Trans. Antennas Propag.*, 2014, **62**, (4), pp. 2000-2007
- 5 Pa, P., Larimore, Z., Parsons, P., and Mirotznik, M.: 'Multi-material additive manufacturing of embedded low-profile antennas', *Electron. Lett.*, 2015, **51**, (20), pp. 1561-1562

6 Kim, S., Yu-Jiun, R., Hoseon, L., Rida, A., Nikolaou, S., and Tentzeris, M.M.: 'Monopole Antenna with Inkjet-Printed Ebg Array on Paper Substrate for Wearable Applications', *IEEE Antennas Wireless Propag. Lett.*, 2012, **11**, pp. 663-666

7 Chauraya, A., Whittow, W.G., Vardaxoglou, J.C., Yi, L., Torah, R., Yang, K., Beeby, S., and Tudor, J.: 'Inkjet printed dipole antennas on textiles for wearable communications', *IET Microw. Antennas Propag.*, 2013, **7**, (9), pp. 760-767

8 Formlabs (<http://formlabs.com/>), accessed 11/12/2016

9 Cartesian Co (<http://cartesianco.com/>), accessed 11/12/2016