



Papanikolaou, V., & Sextos, A. (2016). Design charts for rectangular R/C columns under biaxial bending: A historical review towards a Eurocode-2 compliant update. *Engineering Structures*, 115, 196-206. DOI: 10.1016/j.engstruct.2016.02.033

Peer reviewed version

Link to published version (if available):
[10.1016/j.engstruct.2016.02.033](https://doi.org/10.1016/j.engstruct.2016.02.033)

[Link to publication record in Explore Bristol Research](#)
PDF-document

University of Bristol - Explore Bristol Research

General rights

This document is made available in accordance with publisher policies. Please cite only the published version using the reference above. Full terms of use are available:
<http://www.bristol.ac.uk/pure/about/ebr-terms.html>

Engineering Structures

Elsevier Editorial System(tm) for

Manuscript Draft

Manuscript Number: ENGSTRUCT-D-15-01757R1

Title: Design charts for rectangular R/C columns under biaxial bending :
A historical review towards a Eurocode-2 compliant update.

Article Type: Research Paper

Keywords: Reinforced concrete; biaxial bending; design charts; columns;
Eurocodes

Corresponding Author: Dr. Vassilis K. Papanikolaou, Ph.D.

Corresponding Author's Institution: Aristotle University of Thessaloniki

First Author: Vassilis K. Papanikolaou, Ph.D.

Order of Authors: Vassilis K. Papanikolaou, Ph.D.; Anastasios G Sextos,
Dipl. Eng., MSc DIC, PhD

Abstract: The objective of this paper is to review the historical context of design charts for rectangular reinforced concrete columns under biaxial bending, critically assess their evolution in time and provide a new series, compliant to the latest draft of Eurocode 2. The motivation for such a development arises from the different assumptions and recommended values prescribed in the respective National Annexes of individual countries that use the Eurocodes, which essentially yield impossible to design without the aid of specialized, typically commercial, computer codes. Along these lines, a new extensive design chart dataset of unprecedented output quality is made available herein that covers both normal and high-strength concrete as well as different steel grades. The dataset developed is fully validated against conventional procedures while the error induced in design by the use of older design aids is comparatively assessed, clearly highlighting the necessity for a new design charts dataset at least under certain loading and reinforcement configurations. The present charts are expected to provide a valuable tool for the professional community, facilitate the use of Eurocodes and minimize the epistemic uncertainty associated with the use of older or incompatible design charts in the design of reinforced concrete members.

Design charts for rectangular R/C columns under biaxial bending: A historical review towards a Eurocode-2 compliant update.

Vassilis K. Papanikolaou¹ and Anastasios G. Sextos^{1,2}

¹Civil Engineering Dept., Aristotle University of Thessaloniki, P.O. Box 482, Thessaloniki, 54124, Greece.

²Civil Engineering Dept., University of Bristol, BS8 1TR, Bristol, United Kingdom.

Abstract

The objective of this paper is to review the historical context of design charts for rectangular reinforced concrete columns under biaxial bending, critically assess their evolution in time and provide a new series, compliant to the latest draft of Eurocode 2. The motivation for such a development arises from the different assumptions and recommended values prescribed in the respective National Annexes of individual countries that use the Eurocodes, which essentially yield impossible to design without the aid of specialized, typically commercial, computer codes. Along these lines, a new extensive design chart dataset of unprecedented output quality is made available herein that covers both normal and high-strength concrete as well as different steel grades. The dataset developed is fully validated against conventional procedures while the error induced in design by the use of older design aids is comparatively assessed, clearly highlighting the necessity for a new design charts dataset at least under certain loading and reinforcement configurations. The present charts are expected to provide a valuable tool for the professional community, facilitate the use of Eurocodes and minimize the epistemic uncertainty associated with the use of older or incompatible design charts in the design of reinforced concrete members.

Keywords: Reinforced concrete; biaxial bending; design charts; columns; Eurocodes.

1. Introduction

Reinforced concrete (R/C) elements are usually subjected to a combined action of biaxial bending with axial load, due to their geometry, position/orientation in the structure and, mainly, external actions. In the common case of vertical R/C elements (e.g. structural columns, bridge piers) subjected to horizontal seismic or wind loading, the above biaxial flexural stress condition at the ultimate limit state (ULS) becomes critical for their design or assessment. With the contribution of past (e.g. [1–10]) and more recent (e.g. [11–18]) research, as well as the associated software implementations (e.g. [19]), the laborious numerical solution of biaxial bending is now considered to be sufficiently well developed for use in practice. Naturally, the use of traditional design aids (in the form of tables and charts) has been gradually declined. However, there are convincing reasons to still consider design charts as a valuable tool for use in practice. Firstly, there is a number of assumptions (mostly concerning section geometry representation and material constitutive laws) as well as solution algorithms employed in commercial software that are usually obscured, i.e., treated in a black-box sense by the engineer, thus hindering the imperative need for end-user verification. In this case, validated design charts may provide a solid reference for comparison purposes. Secondly, design charts may still provide a quick and error-proof design/assessment tool for common R/C section in office or at the construction site, especially during preliminary design stages. Last but not least, design charts remain irreplaceable for educational purposes; not only they provide tangible and quick design/assessment results in learning environments (e.g. lectures, projects and exams) but also enhance, by means of visual representation, the students' engineering perspective and judgment.

Unfortunately, when designing to the Eurocodes, it is not possible to use a uniform set of design charts for R/C members to biaxial bending among all Eurocode-complaint countries. This is

due to the fact that there are specific parameters involved in the strength computation process (e.g. the reducing factor taking into account ‘long term effects on the concrete compressive strength) that are essentially country-dependent, as they take different (recommended) values according to the respective National Annexes.

Based on the above, the objective of this paper is threefold:

- (a) to review the historical context of the evolution over the past decades of the design aids used for rectangular R/C columns under biaxial bending, in order to back track the missing pieces of concrete design history, hopefully providing for the first time the limitations of the conventional charts, highlighting the challenges to be met and identifying the emerging needs for updating the existing ones.
- (b) provide a series of new generation, high quality design charts, that are automatically generated through a generic approach, according to the provisions of the latest version of Eurocode 2 (EN1992-1-1) [20]. This extensive dataset covers both normal and high-strength concrete as well as different steel grades and is available online in the Journal website (as supplementary material) for use from the wider engineering scientific and professional community.
- (c) validate the tool that is ad-hoc developed for the generation of the new chart dataset against older charts that reflect the assumptions made on previous design codes, while quantifying the error that is currently introduced by the use of older version design charts in the light of Eurocode 2 implementation.

2. A critical historical review

The pioneering work on biaxial design charts for rectangular R/C sections is accredited to Grasser and Linse [21,22], based on the regulations of the German Concrete Code (DIN1045) of the time [23] (Fig. 1). The stress-strain response of concrete is described by a parabolic-

rectangular law with a compressive strength of β_R (based on concrete class) and a yield and crushing strain of -2‰ and -3.5‰ , respectively (constant for all concrete classes). The reinforcement steel response is based on a bilinear perfectly-elastoplastic law (no hardening considered) with a tensile strength of β_S (based on steel grade), an elastic modulus of $E_e = 21,000 \text{ kg/mm}^2$ ($= 210 \text{ GPa}$) and a rupture strain of 5‰ . The above material constitutive laws can form all potential failure states for a rectangular R/C section, depending on any arbitrary neutral axis depth and orientation. Specifically, failure can be attained either by reinforcement rupture ($\epsilon_e = 5\text{‰}$), concrete crushing under flexure ($\epsilon_b = -3.5\text{‰}$) or concrete crushing under prevailing compression ($\epsilon_b = -2\text{‰}$, point A in Fig. 1), where ϵ_e and ϵ_b are steel and concrete strains, respectively. An important characteristic of the aforementioned formulation is that the section stress state was based on the obsolete *working stress* design concept i.e. no partial safety factors are pre-applied to material properties and design forces (service loads are used instead). However, at the final stage of establishing equilibrium between section resistance (calculated by stress integration) and external loading, a variable global safety factor ($v = 1.75 \sim 2.10$) equal to their ratio is imposed, depending on the resultant failure type.

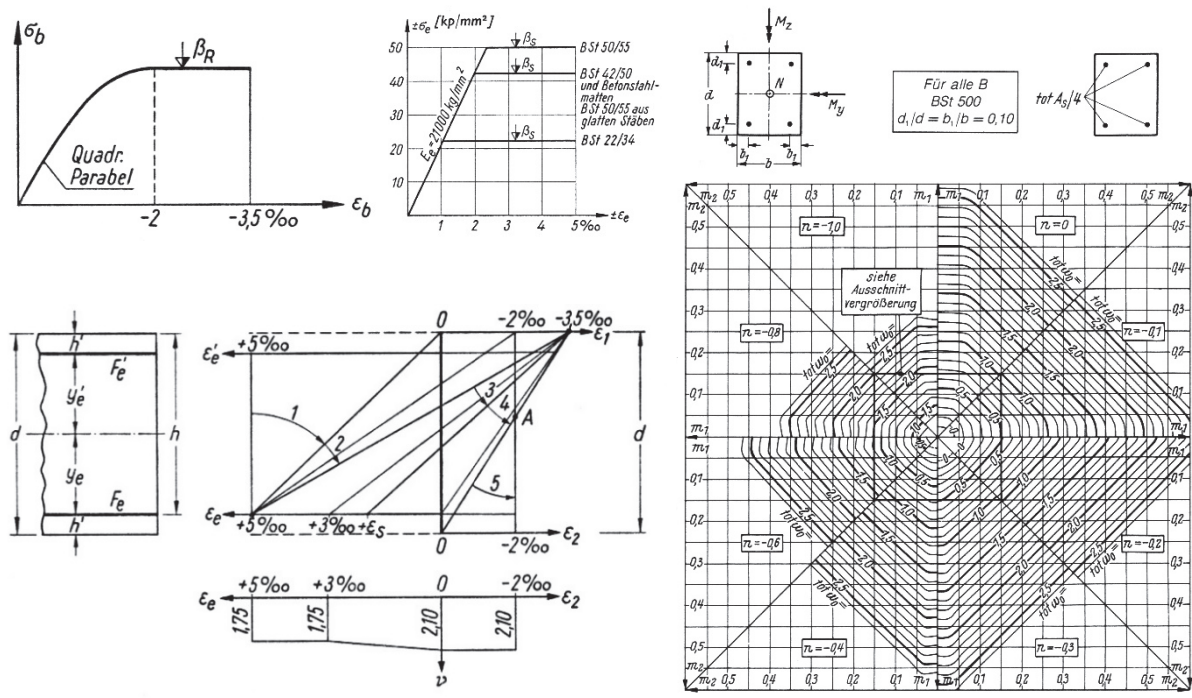

Fig. 1. Material constitutive laws, failure state definition and biaxial design charts according to DIN1045 [22]

The basic form of the biaxial design chart follows a Cartesian grid with axes corresponding to two perpendicular normalized moments ($m_1 > m_2$), divided into eight triangular (45°) zones corresponding to constant normalized axial force levels (n) (also called ‘Rosetta-type’ graphs). For a set of two external moments and an axial load, the corresponding value of reinforcement mechanical ratio (ω_0) is graphically picked from the chart, leading to the calculation of design reinforcement area (formulas will be provided later). A series of design charts [22] may correspond to different reinforcement arrangements (the most useful of which are the distributed and the 4-corner-bar types), different cover-to-dimension ratios (i.e. reinforcement position) and different steel grades. An important note is that since (a) normalized values are applied and (b) yield/crushing concrete strains are constant, every design graph is applicable to any concrete class. On the contrary, different charts should be provided for different steel grades, since steel yield strain (β_s/E_e) depends on tensile strength.

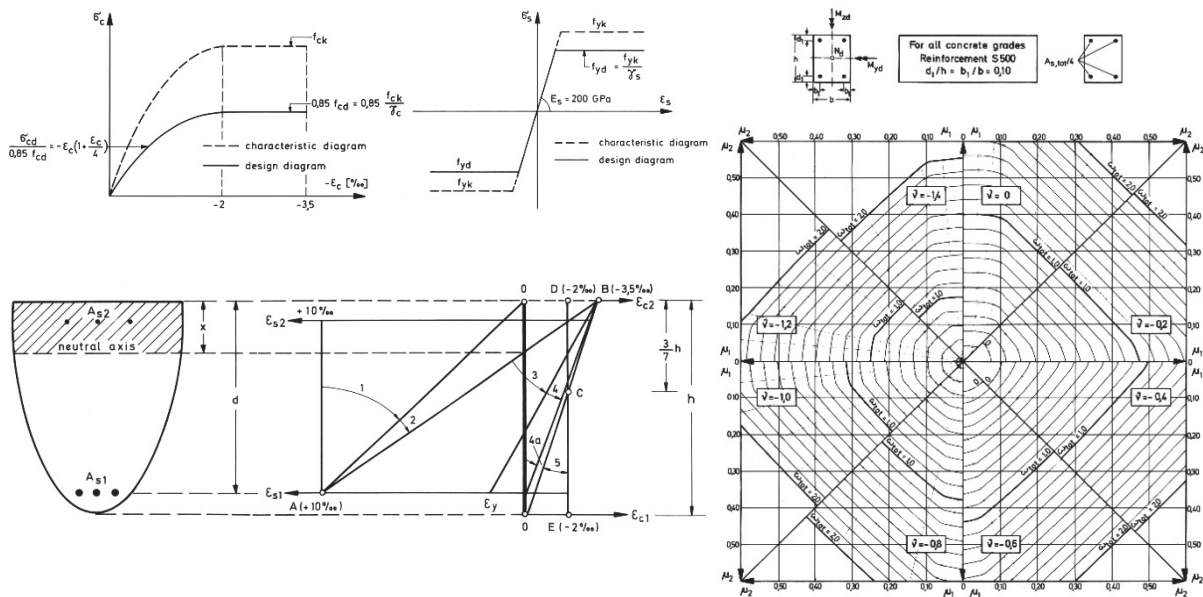

Fig. 2. Material constitutive laws, ULS definition and biaxial design charts according to CEB/FIP [24]

With the advent of the *ultimate limit state* (ULS) design philosophy, the DIN1045-based design charts had to be revised, since the aforementioned global safety factor (ν) needed to be replaced with partial safety factors for material properties and external actions. Therefore, about 10 years later, a new set of design charts was issued by CEB/FIP, under the chairmanship of Prof. E. Grasser [24] (Fig. 2). As far as the material properties are concerned, β_R and β_S were replaced by $f_{cd} = f_{ck}/\gamma_c$ and $f_{yd} = f_{yk}/\gamma_s$ for concrete and steel, respectively, where f_{cd} , f_{yd} are design strengths, f_{ck} , f_{yk} are their characteristic counterparts and γ_c , γ_s are partial safety factors. The response curves for both materials were unaltered, with only steel ultimate strain doubled to 10%. The potential ultimate limit (failure) states were modified accordingly, producing a new series of biaxial design charts that were broadly utilized until recently, even if slight code modifications occurred in the meantime, particularly due to advances in steel technology (e.g. steel ultimate strain further increased to 20% in [25]). A meticulous comparison between DIN1045 (Fig. 1) and CEB/FIP (Fig. 2) charts shows that for - approximately - the same chart type and for the same external loading, the former yields considerably larger reinforcement

mechanical ratios; this is mainly attributed to the different design philosophy i.e. service vs. ultimate load input, which justified the above revision.

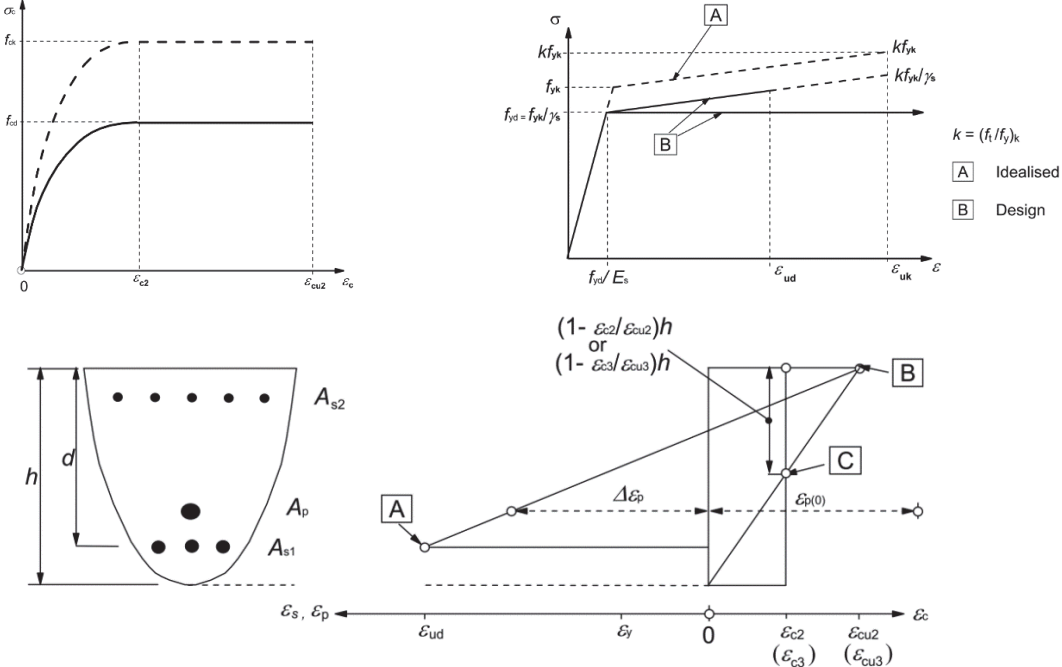

Fig. 3. Material constitutive laws and ULS definition according to EN1992-1-1 [20]

The recent unification of structural design national codes of EU countries under the new set of Eurocode drafts has brought a few modifications which render the previous CEB/FIP charts unsuitable, under certain conditions (Fig. 3). The most important difference is that Eurocode 2 (EN1992-1-1) [20] specifies concrete design strength as $f_{cd} = \alpha_{cc} \cdot f_{ck} / \gamma_c$, where α_{cc} ($= 0.8 \sim 1.0$) is a reducing factor taking into account ‘long term effects on the compressive strength and unfavorable effects resulting from the way the load is applied’, with a recommended value of unity and open to regulation through each country’s National Annex. On the contrary, CEB/FIB charts had already considered a fixed factor equal to 0.85 for the above effects, which was hardcoded in the stress integration procedure as a post-operator to concrete stress ($0.85 \cdot \sigma_{cd}$, see Fig. 2). As a result, this factor cannot be deliberately modified if needed (e.g., the recommended value is 1.0 in all countries, except for Germany, Greece, Italy and Belgium where it remains equal to 0.85). Another difference is that the perfectly-elastoplastic stress-strain bilinear law for

steel now has no upper strain limit ϵ_{ud} (compared to the 10‰ limit in CEB/FIB charts) and becomes finite only if strain hardening (k) is considered. Consequently, for unlimited steel strain, the section ULS is always determined by concrete crushing, either under flexure or prevailing compression. Finally, the formerly established parabolic-rectangular stress-strain relationship for concrete with yield and ultimate strains (ϵ_{c2} , ϵ_{cu2}) equal to -2‰ and -3.5‰ , respectively, ceases to apply for high strength concrete (from class C55/67 and above), where modified values for ϵ_{c2} , ϵ_{cu2} and n (polynomial order of the ascending branch, previously $n = 2$ for parabolic curve) are recommended (Table 3.1 in [20]). It is also noted that Eurocode 2 [20] also provides an alternative concrete constitutive law that exhibits the experimentally observed strain softening of concrete under compression (easily handled by the employed numerical scheme), however, it is currently recommended only for nonlinear structural analysis and not for section design. The above significant novelties require the drafting of a new series of Eurocode-2 compliant design charts, which will be discussed in the subsequent sections.

It has to be noted here that apart from the DIN1045- and CEB-based design charts discussed above, there are also a few other national documents that provide similar design aids, such as the British Standards Institution (BS) [26] and American Concrete Institute (ACI) [27]. The main difference is, however, that the above documents only provide design charts for *uniaxial* bending with axial load without explicitly handling the biaxial bending case, though, an implicit and rather complicated scheme (reciprocal load or load contour method) is recommended by the ACI provisions using approximate modification factors in order to reduce the biaxial problem to its uniaxial equivalent.

3. Computational framework for automated generation of Eurocode-2 compliant design charts

The drafting process of the new Eurocode-2 compliant design charts, was based on a recent and sufficiently validated derivative-free numerical method for analysis of arbitrary composite sections in biaxial bending and axial load [11], which was encapsulated in an ad-hoc software solution. The program features a rectangular R/C section generator with variable reinforcement configurations and material properties, seamlessly connected to a commercial vector design software (CorelDraw™ X7) via its application programming interface (API) (Fig. 4). By selecting the desired design chart type and parameters (i.e. concrete class, steel grade, reinforcement pattern and cover-to-dimension ratio), fully automatic drafting is performed in unprecedented output detail (i.e. infinitely zoomable vector graphics, one-degree curve stepping, ruler-friendly grid scale). A working video is available online.

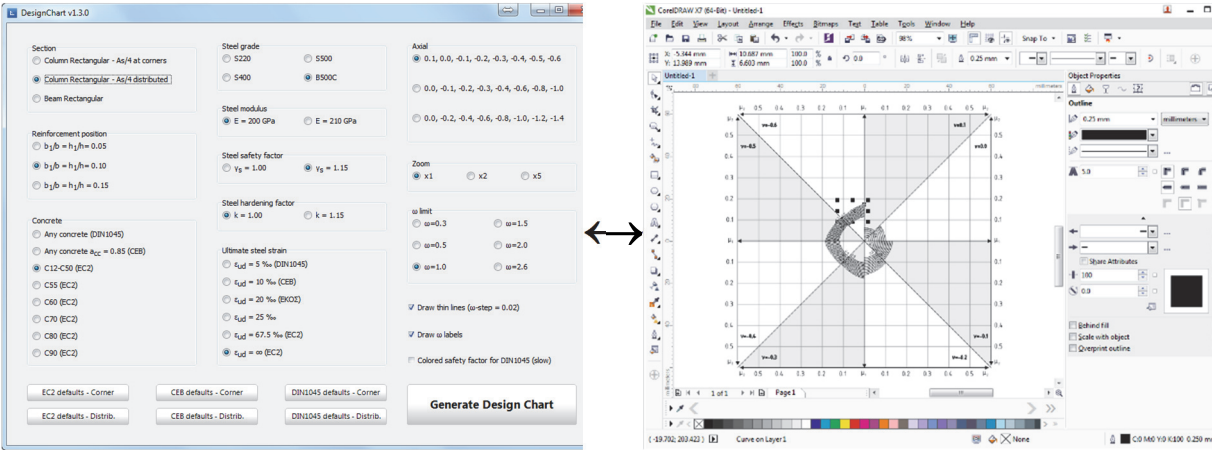

Fig. 4. Developed software tool for automated generation of design charts

4. Validation of the numerical procedure

In order to further validate the present numerical procedure, an additional option for performing back-analysis was also implemented, based on the specific assumptions of the previous DIN1045 and CEB/FIP implementations, as described in the previous section. Figs. 5

and 6 depict a set of those charts, upon which the results of the present back-analysis were overlaid. It is observed that the correlation is perfect (colored curves from present analysis over original black curves, see also Figs. 1 and 2 – hardly visible herein due to perfect correlation), which certifies the reliability and robustness of the numerical scheme. More specifically, in Fig. 5 (DIN1045 charts), the global safety factor value (v) together with the reinforcement failure regions are depicted in color contour form (red color for reinforcement failure regions: $\epsilon_c = 5\%$ and yellow to blue color gradient for the entire safety factor range: $v = 1.75$ to 2.10), a visual that was not previously available. It is also noted that, particularly for distributed reinforcement configuration, the employed numerical scheme [11] performs explicit line integration instead of multiple-point (fiber) discretization, leading to enhanced output detail.

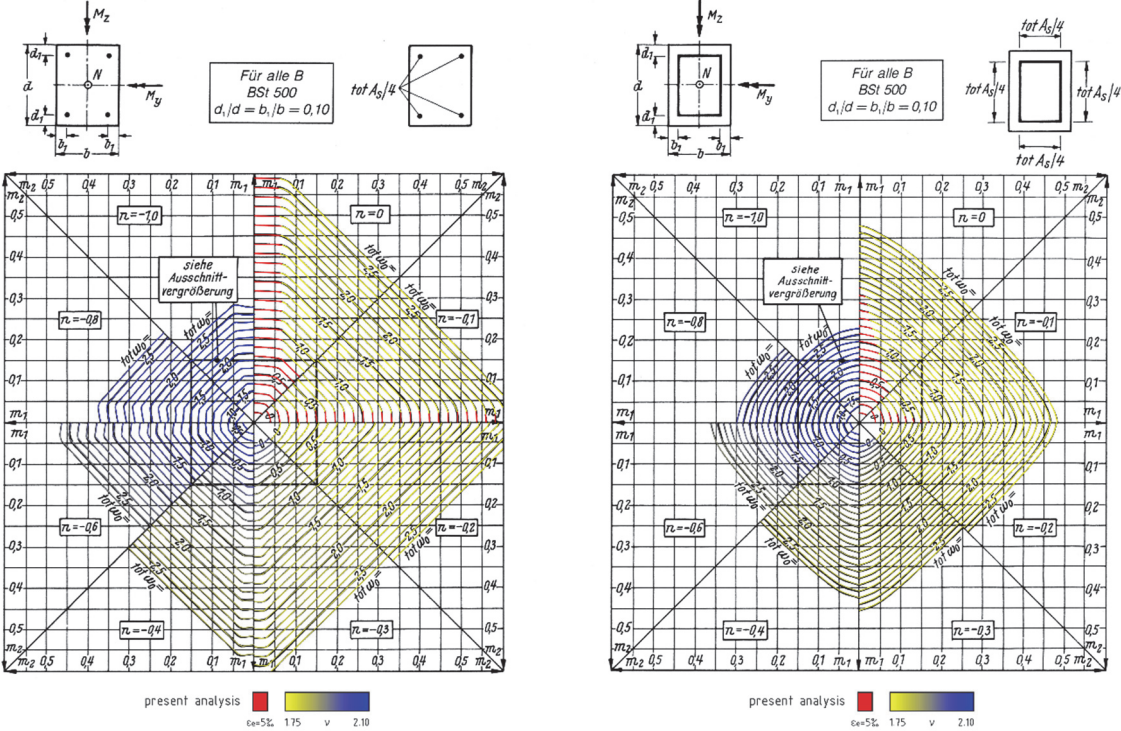

Fig. 5. Comparison between original DIN1045 [22] charts and present analysis (left: reinforcement at four corners, right: distributed reinforcement)

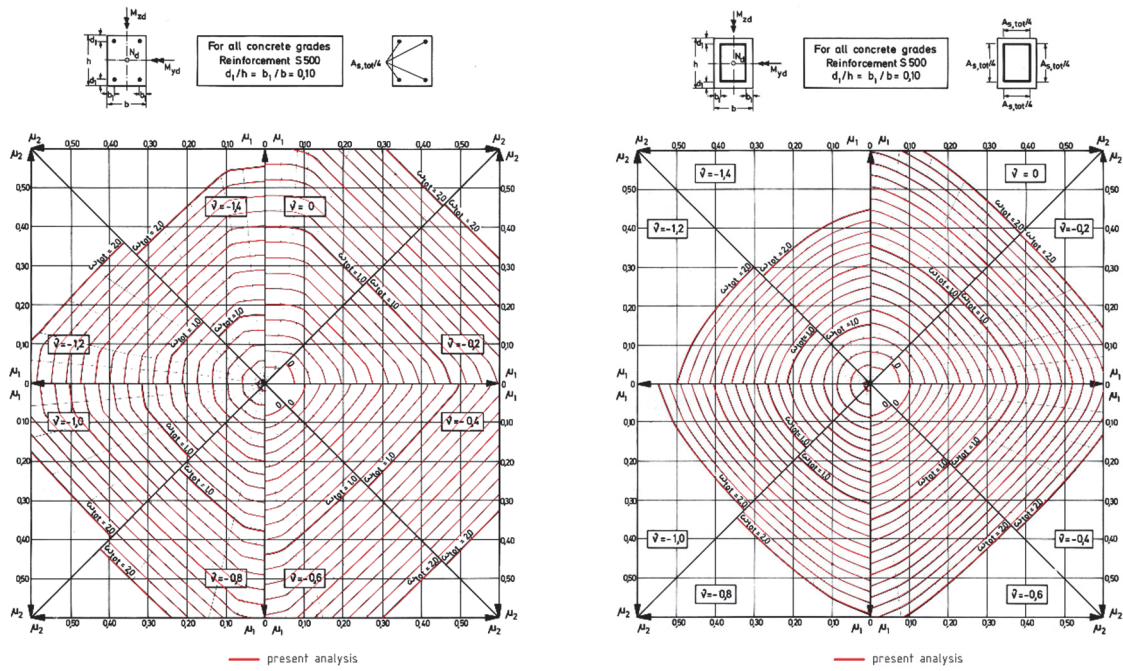

Fig. 6. Comparison between original CEB/FIP [24] charts and present analysis (left: reinforcement at four corners, right: distributed reinforcement)

5. New Eurocode-2 compliant design charts

The basic form of the new design charts for rectangular R/C sections under biaxial bending is depicted in Figs. 7 and 8 for the two most usable types i.e. 4 reinforcement bars at corners and distributed reinforcement across the column perimeter, respectively. These two patterns can cover not only the majority of rectangular column and bridge pier designs but also that of rectangular structural walls (examples provided in the next section). Other parameters are the concrete class, steel grade and cover-to-dimension ratio ($b_1/b = d_1/d$) (Table 1). Overall, a number of 54 Eurocode-2 compliant design charts were generated, available online.

The provided range of normalized axial loading v for which charts are generated is from tensile $+0.1$ to compressive -0.6 , in 0.1 steps, and is deemed sufficient for the vast majority of design load cases. It is notable that Eurocode 8 [28] for seismic design sets an upper limit of $v = 0.65$ for medium and $v = 0.55$ for high ductility class structures (DCM and DCH,

respectively). All specific parameters (in EN1992-1-1 notation [20]) as well as the required formulas normalized actions and design reinforcement area (A_s) are included in the graph header for proper reference.

Table 1. Design chart configurations available online

Reinforcement arrangement	Concrete class	Steel grade	Cover-to-dimension ratio	Extra
4 bars at corners	C12 to C50	S220, B500C	0.05, 0.10, 0.15	zoomed regions
	C55, C60, C70, C80, C90	B500C	0.05, 0.10, 0.15	-
distributed	C12 to C50	S220, B500C	0.05, 0.10, 0.15	zoomed regions
	C55, C60, C70, C80, C90	B500C	0.05, 0.10, 0.15	-

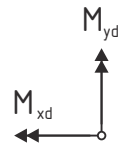
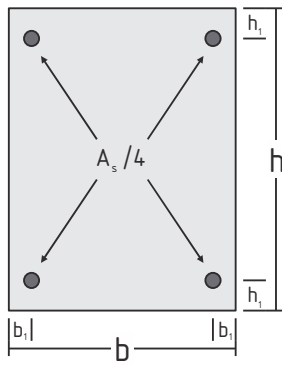

C12-C50 : $\epsilon_{c2} = 2.0\%$, $\epsilon_{cu2} = 3.5\%$, $n = 2$

B500C : $\gamma_s = 1.15$, $k = 1.00$, $\epsilon_{ud} = \infty$

$$b_1 / b = h_1 / h = 0.10$$

$$v = N_d / (b \cdot h \cdot f_{cd}) \quad \mu_1 = \max(\mu_x, \mu_y)$$

$$\mu_x = |M_{xd}| / (b \cdot h^2 \cdot f_{cd}) \quad \mu_2 = \min(\mu_x, \mu_y)$$

$$\mu_y = |M_{yd}| / (b^2 \cdot h \cdot f_{cd}) \quad A_s = \omega \cdot b \cdot h \cdot (f_{cd} / f_{yd})$$

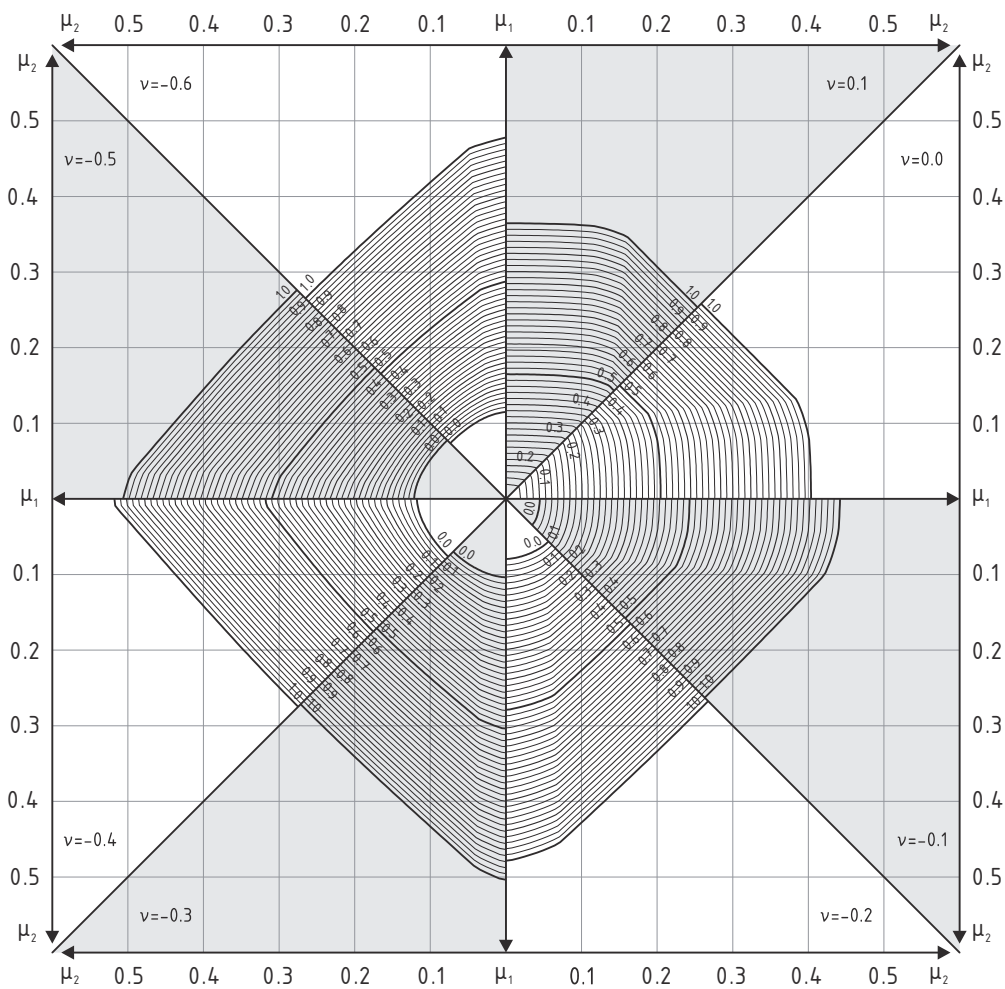
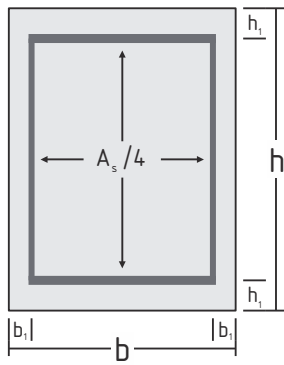

Fig. 7 Design chart for rectangular columns with 4 bars at corners, C12-C50, B500C, $b_1/b = h_1/h = 0.10$



C12-C50 : $\epsilon_{c2} = 2.0\%$, $\epsilon_{cu2} = 3.5\%$, $n = 2$

B500C : $\gamma_s = 1.15$, $k = 1.00$, $\epsilon_{ud} = \infty$

$$b_1 / b = h_1 / h = 0.10$$

$$v = N_d / (b \cdot h \cdot f_{cd}) \quad \mu_1 = \max(\mu_x, \mu_y)$$

$$\mu_x = |M_{xd}| / (b \cdot h^2 \cdot f_{cd}) \quad \mu_2 = \min(\mu_x, \mu_y)$$

$$\mu_y = |M_{yd}| / (b^2 \cdot h \cdot f_{cd}) \quad A_s = \omega \cdot b \cdot h \cdot (f_{cd} / f_{yd})$$

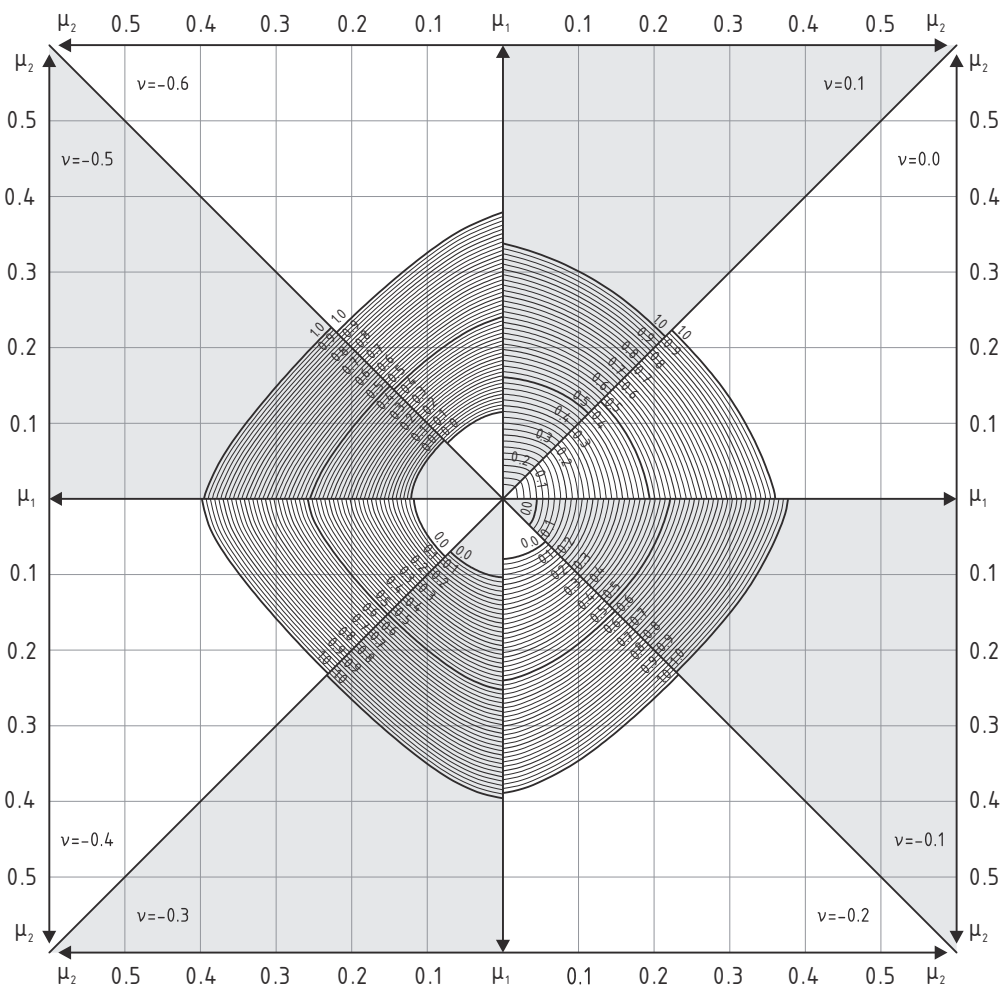

Fig. 8 Design chart for rectangular columns with distributed reinforcement, C12-C50, B500C, $b_1/b = h_1/h = 0.10$

6. Comparison with previous implementations

In this section, the relative error is quantified between the formerly established design charts of CEB/FIP [24] and the new Eurocode-2 compliant charts presented herein. This quantification is deemed important in order to pinpoint the loading ranges wherein the error may be considerable during design, as well as the areas where this difference can be considered negligible and the conventional design charts can be safely used.

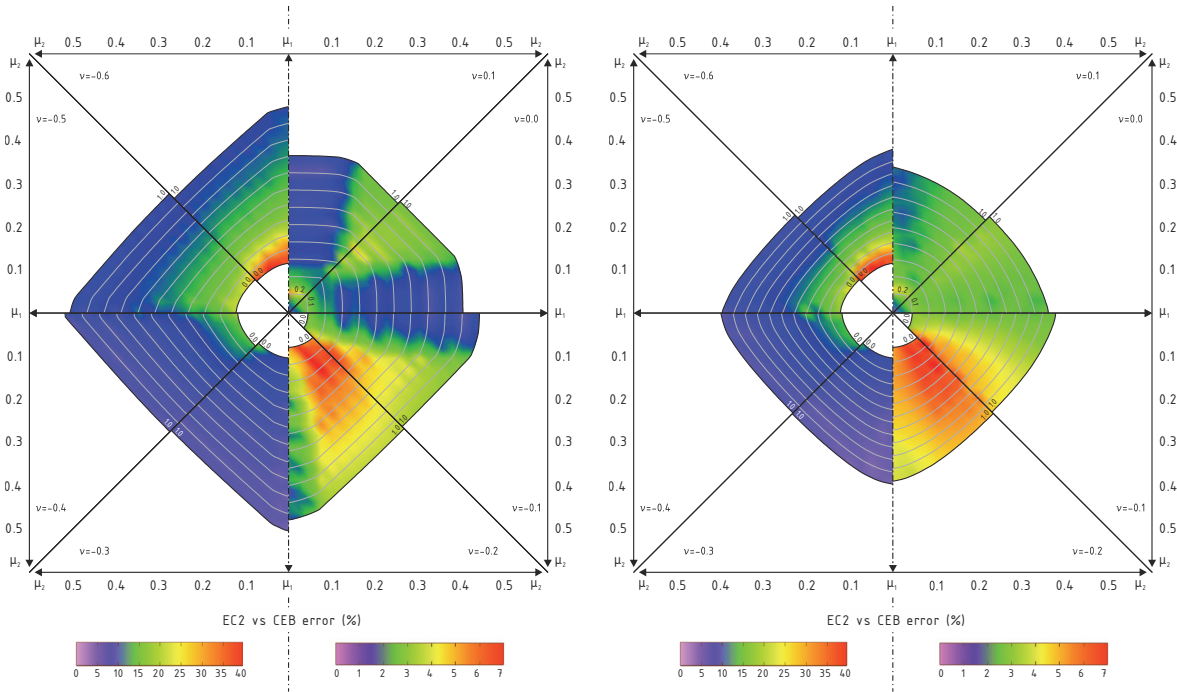

Fig. 9. Error quantification between CEB/FIP [24] and present design charts
(left: corner reinforcement, right: distributed reinforcement)

Figure 9 in particular shows the relative errors between Eurocode-2 and CEB/FIP [24] charts in a form of color contours (overlaid on the Eurocode-2 charts) for the typical case of $b_1/b = h_1/h = 0.10$, both for corner and distributed reinforcement (corresponding to Figs. 7- 8 and Fig. 6, respectively). It is firstly observed that the error sign is always positive, which corresponds to higher reinforcement requirements using the former CEB/FIP [24] charts, for the same set of

actions. This requirement is generally greater under higher axial compression, reaching an extreme of about 40% for significantly compressive axial loads ($v = -0.6$) and low moment actions (μ_1, μ_2). This observation is justified by the fact that for higher compression, the section compressive zone (area) becomes larger and the concrete material starts to play the predominant role in the section response. The latter leads to larger differences due to ‘long-term effect factor’ which is hardcoded in the CEB/FIP [24] charts, as described earlier. For lower axial compression, this difference drops significantly, yet it is still more pronounced for lower moment actions that enlarge the concrete compression zone. It is also observed that, for the same axial load (v) and reinforcement level (ω) the relative error is more significant for biaxial bending (maximizes for the equibiaxial case $\mu_1 = \mu_2$) and considerably decreases to negligible levels for uniaxial bending. It is finally shown that for distributed reinforcement (Fig. 9, right), the error is more significant than the case of 4 bars at corners (Fig. 9, left), especially for lower axial levels.

From the above investigation it is generally concluded that for the most frequent design cases (i.e. $v = -0.2 \sim -0.4$, $\omega = 0.1 \sim 0.3$ and distributed reinforcement), the new Eurocode-2 design charts may lead to an approximate 10% mean reduction in the required reinforcement, that is, the use of conventional (i.e., DIN-compliant) design charts is a conservative decision.

7. Worked examples

Having presented the main features of the new, Eurocode-2 compliant design charts generated for R/C members subject to biaxial bending moment and axial load, validated the computational tool developed and provided an overview of the properties of the chart set made available online, two demonstration examples are discussed below. The purpose of this demonstration is to confirm the applicability, ease of use and usefulness of the new design

charts, as well as to act as benchmark problems for further reference. The two examples involve (a) a rectangular R/C column and (b) a rectangular R/C structural wall as described in the following.

Example A

Consider a rectangular column sized $b \times h = 600 \times 500$ mm with C20/25 concrete ($\alpha_{cc} = 1.0$) and B500C steel (Fig. 10a). The concrete nominal cover due to environmental conditions is set to 30 mm and the total distance to the center of reinforcement is equal to $30 + \varnothing_w + \varnothing_l/2 \approx 30 + 10 + 20/2 = 50$ mm (\varnothing_w and \varnothing_l are normally assumed hoop and longitudinal reinforcement diameter, respectively). The resulting cover-to-reinforcement ratios are $b_1/b = 50/600 = 0.083$ and $h_1/h = 50/500 = 0.10$. At this point, since graphs always impose $b_1/b = h_1/h$ (otherwise eight-partite symmetry would be violated), a conservative choice should be to keep the larger of the two ratios (i.e. 0.10). Using the above parameters, the selected graph is that of Fig. 8 and the resulting column geometry is shown in Fig. 10b. For a set of external actions e.g. $N_d = -400$ kN (compressive), $M_{xd} = 100$ kNm and $M_{yd} = 480$ kNm, the normalized values are:

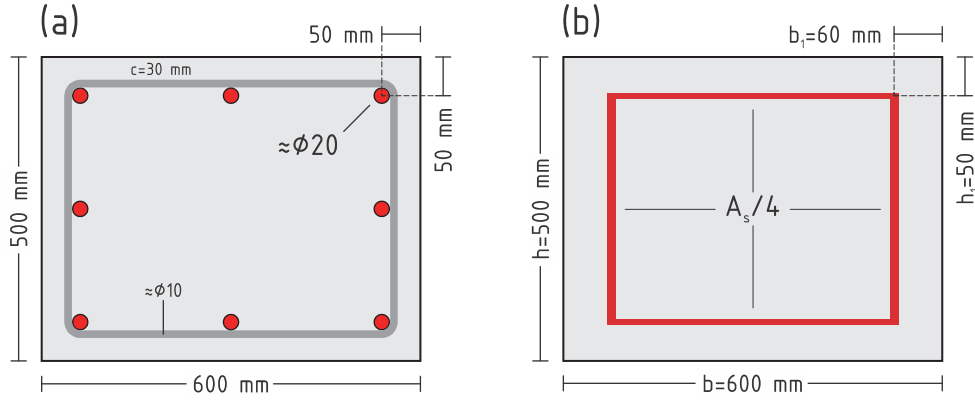

Fig. 10. Application example for a rectangular R/C column.

$$\left. \begin{aligned}
 \mu_x &= \frac{M_{xd}}{b \cdot h^2 \cdot f_{cd}} = \frac{100}{0.6 \cdot 0.5^2 \cdot 20000 / 1.5} = 0.05 \\
 \mu_y &= \frac{M_{yd}}{b^2 \cdot h \cdot f_{cd}} = \frac{480}{0.6^2 \cdot 0.5 \cdot 20000 / 1.5} = 0.20 \\
 v &= \frac{N}{b \cdot h \cdot f_{cd}} = \frac{-400}{0.6 \cdot 0.5 \cdot 20000 / 1.5} = -0.10
 \end{aligned} \right\} \Rightarrow \left. \begin{aligned}
 \mu_1 &= \max(\mu_x, \mu_y) = 0.20 \\
 \mu_2 &= \min(\mu_x, \mu_y) = 0.05 \\
 v &= -0.10
 \end{aligned} \right\} \begin{array}{l} \text{graph} \\ \text{Fig.8} \end{array} \Rightarrow \omega = 0.485 \quad (1)$$

and the mechanical reinforcement ratio ($\omega = 0.485$) is picked from the corresponding graph triangular region for a constant normalized axial force $v = -0.1$. The calculated design reinforcement area and derived number/diameter of reinforcement bars are:

$$A_s = \omega \cdot b \cdot h \cdot \frac{f_{cd}}{f_{yd}} = 0.485 \cdot 60 \cdot 50 \cdot \frac{20 / 1.5}{500 / 1.15} = 44.6 \text{ cm}^2 \Rightarrow 8\text{Ø}20 + 8\text{Ø}18 (45.5 \text{ cm}^2) \quad (2)$$

It is recalled that in the common case when the cover-to-dimension or normalized axial force values do not coincide with the respective chart, a linear interpolation between cover ratios (i.e. for 0.05, 0.10, 0.15) or normalized axial force (+0.1 ~ -0.6), respectively, is recommended.

Example B

It is not trivial whether the suggested design graphs are also applicable to structural walls, since their geometry and reinforcement configuration is significantly different than columns (flexural moments are resisted by a lever arm formed between two distant confined boundaries). However, with an acceptable level of approximation, a structural wall can be modeled using a four-corner-bar configuration. The herein considered structural wall has dimensions of $b \times h = 2000 \times 250$ mm with C20/25 concrete ($\alpha_{cc} = 1.0$) and B500C steel (Fig. 11a). There are two confined regions of 375 mm length where it is assumed that their total reinforcement is lumped to their middle, so that a four-corner-bar configuration is formed, with $b_1 = 222.5$ mm (Fig. 11b). For $b_1/b = 222.5/2000 = 0.11 \approx 0.10$, the graph of Fig. 7 becomes the one appropriate for design (note that h_1/h is now ignored, since the wall flexural action is dominant along its long dimension).

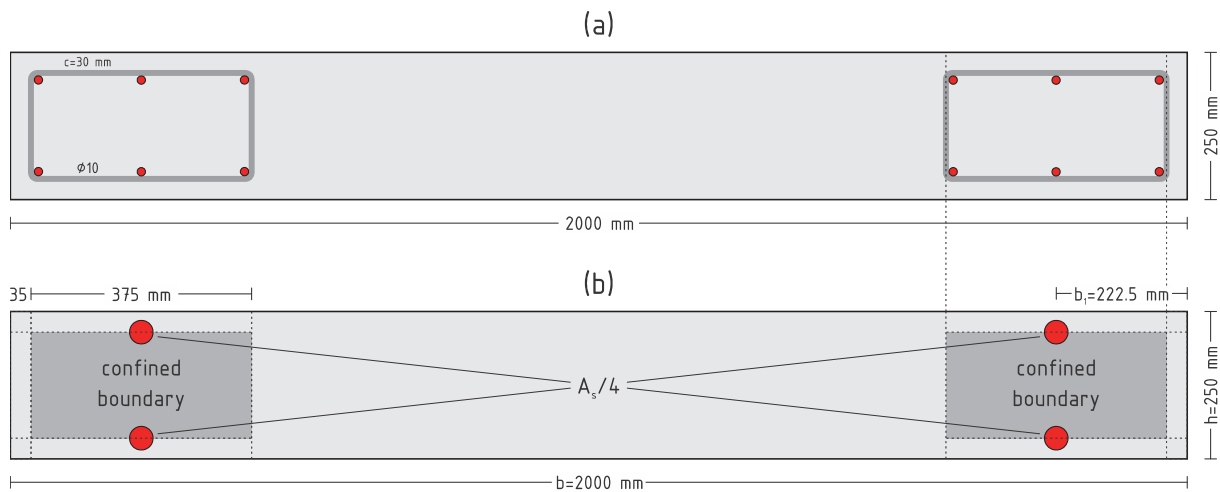

Fig. 11. Application example for a rectangular R/C structural wall.

For a set of external actions e.g. $N_d = -1340$ kN (compressive), $M_{xd} = 167$ kNm (secondary) and $M_{yd} = 2670$ kNm (primary), the normalized values, calculated design reinforcement area and derived number/diameter of reinforcement bars per confined boundary are:

$$\left. \begin{aligned} \mu_x &= \frac{M_{xd}}{b \cdot h^2 \cdot f_{cd}} = \frac{167}{2.0 \cdot 0.25^2 \cdot 20000 / 1.5} = 0.10 \\ \mu_y &= \frac{M_{yd}}{b^2 \cdot h \cdot f_{cd}} = \frac{2670}{2.0^2 \cdot 0.25 \cdot 20000 / 1.5} = 0.20 \\ v &= \frac{N}{b \cdot h \cdot f_{cd}} = \frac{-1340}{2.0 \cdot 0.25 \cdot 20000 / 1.5} = -0.20 \end{aligned} \right\} \Rightarrow \left. \begin{aligned} \mu_1 &= \max(\mu_x, \mu_y) = 0.20 \\ \mu_2 &= \min(\mu_x, \mu_y) = 0.10 \\ v &= -0.20 \end{aligned} \right\} \begin{array}{l} \text{graph} \\ \text{Fig.7} \end{array} \Rightarrow \omega = 0.435 \quad (3)$$

$$A_s = \omega \cdot b \cdot h \cdot \frac{f_{cd}}{f_{yd}} = 0.435 \cdot 200 \cdot 25 \cdot \frac{20 / 1.5}{500 / 1.15} = 66.7 \text{ cm}^2 \quad (4)$$

$\Rightarrow 8\text{Ø}20 + 4\text{Ø}16$ (33.2 cm²) per confined boundary

An important note is that the above graphs may also be used in a reverse fashion, i.e. to calculate the resistance moment (M_{Rd}) of columns/walls for a predefined axial load (v) by specifying the mechanical ratio of the provided reinforcement (ω) and – optionally – the secondary moment (μ_2 : if set to zero, the uniaxial resistance moment is calculated instead). The above procedure is particularly useful in capacity design checks for seismic design [28] and is described in the next example.

Example C

Consider the same rectangular column described in Example A, already reinforced with 16Ø20 bars (a bit more than initially designed for) corresponding to a total area of $A_s = 50.3$ cm². The reverse problem is to find the resistance moment (M_{Rd}) along its larger axis ($x = 600$ mm), considering the same normalized axial force ($v = -0.1$) and secondary moment

($\mu_2 = 0.05$) from the analysis. The first step is to calculate the existing mechanical ratio (ω) by reversing Eq. 2 as follows:

$$16\text{Ø}20 (50.3 \text{ cm}^2) \Rightarrow \omega = \frac{A_s}{b \cdot h} \cdot \frac{f_{yd}}{f_{cd}} = \frac{50.3}{60 \cdot 50} \cdot \frac{500/1.15}{20/1.5} = 0.55 \quad (5)$$

By selecting the appropriate 45-degree zone for $v = 0.1$, the intersection between the horizontal line which corresponds to the secondary normalized moment $\mu_2 = 0.1$ and the mechanical reinforcement ratio curve for $\omega = 0.55$ is found. The vertical projection of this intersection on the primary normalized moment (μ_1) axis yields $\mu_1 = 0.22$ (Fig. 12). The final step is to calculate the corresponding resistance moment by reversing Eq. 1 as follows:

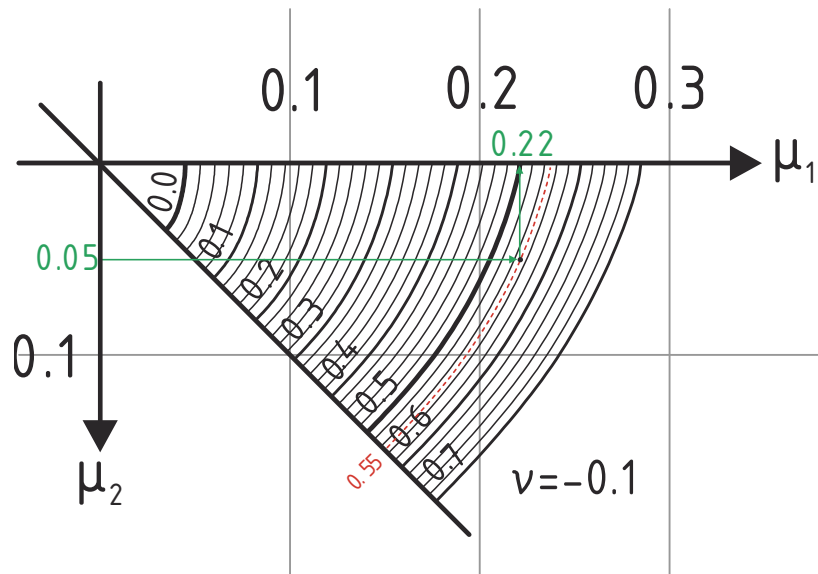

Fig. 12. Calculating the resistance moment for a rectangular R/C column (reverse problem).

$$M_{Rd} = \mu_1 \cdot b \cdot h^2 \cdot f_{cd} = 0.22 \cdot 0.5 \cdot 0.6^2 \cdot 20000 / 1.5 = 528 \text{ kNm} \quad (6)$$

It is observed that the provided amount of reinforcement (16Ø20) renders the section safe against analysis moments ($528 \text{ kN} > 480 \text{ kN}$). It can be therefore concluded that the provided design charts can be also applied for the assessment of existing sections against analysis requirements.

8. Concluding remarks

In this paper, a new series of design charts is presented for rectangular R/C columns under biaxial bending, compliant to the latest draft of Eurocode 2 following a critical assessment of the historical evolution of design aids during the last decades. The necessity for such a review and new dataset development arises from the different assumptions and recommended values that are currently prescribed in the respective National Annexes of individual countries that use the Eurocodes, which essentially yield impossible to design without the aid of specialized, typically commercial, computer codes. A fully automated computer-aided numerical and drafting method is presented, that leads to a new generation, extensive design chart dataset of unprecedented vector quality. It is shown that with the aid of the methodology and software developed it is possible to automatically generate design charts that comply with the individual National Annex of the country of implementation while retaining the maximum possible computational accuracy and visual resolution. It is also demonstrated that the use of the new EC2-compliant design charts presented herein lead to a decrease in the required reinforcement by 5-40% primarily depending on the magnitude of the normalized axial load and the steel configuration (i.e., distributed reinforcement or corner rebars). It is deemed that the present contribution facilitates the use of Eurocodes and most importantly, minimizes the epistemic uncertainty associated with the use of older design charts in the design of contemporary reinforced concrete members.

Acknowledgements

The authors would like to thank George Penelis and Kosmas Stylianidis, Emeriti Professors of Reinforced Concrete at Aristotle University of Thessaloniki, Greece, for their insightful comments regarding the historical aspects of the design chart evolution and the problems arising from design aids misuse. They would also like to thank Michael Fardis, Professor of Reinforced Concrete at the University of Patras, Greece, for his valuable comments and input with respect to the Eurocode 2 drafting panel rationale. Finally, the authors would like to thank Despina Tsertikidou for manually preparing a first set of design charts in the framework of her undergraduate Thesis that were used as an additional reference of validation along with the computational framework presented herein.

References

- [1] Werner H. Schiefe Biegung polygonal umrandeter Stahlbeton-Querschnitte. *Bet Und Stahlbetonbau* 1974;69:92–7.
- [2] Fafitis A. Interaction surfaces of reinforced-concrete sections in biaxial bending. *J Struct Eng ASCE* 2001;127:840–6.
- [3] Chen SF, Teng JG, Chan SL. Design of biaxially loaded short composite columns of arbitrary section. *J Struct Eng ASCE* 2001;127:678–85.
- [4] Bonet JL, Miguel PF, Fernandez MA, Romero ML. Analytical approach to failure surfaces in reinforced concrete sections subjected to axial loads and biaxial bending. *J Struct Eng ASCE* 2004;130. doi:10.1061/(ASCE)0733-9445(2004)130.
- [5] Barros MHFM, Ferreira CC, Barros AFM. Closed form interaction surfaces for nonlinear design codes of RC columns with MC 90. *Comput Concr* 2005;2:55–77.
- [6] Bonet JL, Barros MHFM, Romero ML. Comparative study of analytical and numerical algorithms for designing reinforced concrete sections under biaxial bending. *Comput Struct* 2006;84:2184–93. doi:10.1016/j.compstruc.2006.08.065.
- [7] Charalampakis AE, Koumousis VK. Ultimate strength analysis of composite sections under biaxial bending and axial load. *Adv Eng Softw* 2008;39:923–36.
- [8] Rosati L, Marmo F, Serpieri R. Enhanced solution strategies for the ultimate strength analysis of composite steel-concrete sections subject to axial force and biaxial bending. *Comput Methods Appl Mech Eng* 2008;197:1033–55.
- [9] da Silva VD, Barros MHFM, Julio EN, Ferreira CC. Closed form ultimate strength of multi-rectangle reinforced concrete sections under axial load and biaxial bending. *Comput Concr* 2009;6:505–21.
- [10] Chiorean CG. Computerised interaction diagrams and moment capacity contours for

- composite steel-concrete cross-sections. *Eng Struct* 2010;32:3734–57.
- [11] Papanikolaou VK. Analysis of arbitrary composite sections in biaxial bending and axial load. *Comput Struct* 2012;98-99:33–54.
- [12] Fossetti M, Papia M. Dimensionless analysis of RC rectangular sections under axial load and biaxial bending. *Eng Struct* 2012;44:34–45.
doi:10.1016/j.engstruct.2012.05.049.
- [13] Marmo F, Rosati L. Analytical integration of elasto-plastic uniaxial constitutive laws over arbitrary sections. *Int J Numer Methods Eng* 2012;91:990–1022.
- [14] Marmo F, Rosati L. The fiber-free approach in the evaluation of the tangent stiffness matrix for elastoplastic uniaxial constitutive laws. *Int J Numer Methods Eng* 2013;94:868–94.
- [15] Vinciprova F, Oliveto G. Ultimate Strength Domain of Reinforced Concrete Sections under Biaxial Bending and Axial Load. *ACI Struct J* 2013;1:3–14.
- [16] Matuszak A, Pluciński P. Accuracy of cross-section stress numerical integration by boundary integration formulae. In: Łodygowski Tomasz, Rakowski Jerzy LP, editor. *Recent Adv. Comput. Mech.*, CRC Press; 2014, p. 111–20.
- [17] Vaz Rodrigues R. A new technique for ultimate limit state design of arbitrary shape RC sections under biaxial bending. *Eng Struct* 2015;104:1–17.
doi:10.1016/j.engstruct.2015.09.016.
- [18] Monti G, Petrone F. Yield and Ultimate Moment and Curvature Closed-Form Equations for Reinforced Concrete Sections. *ACI Struct J* 2015;112.
doi:10.14359/51687747.
- [19] Papanikolaou VK. AnySection : Software for the analysis of arbitrary composite sections in biaxial bending and axial load, Aristotle University of Thessaloniki, Greece 2015.
- [20] CEN [European Committee for Standardization]. Eurocode 2. Design of concrete structures – Part 1–1: General rules and rules for buildings (EN 1992-1-1). Brussels: 2004.
- [21] Grasser E, Linse D. Neuartige Diagramme für die Bemessung von Stahlbeton-Rechteckquerschnitten bei schiefer Biegung auf der Grundlage von DIN 1045 E. *Beton- Und Stahlbetonbau* 1970;4.
- [22] Grasser E, Linse D. Bemessungstabellen für Stahlbetonquerschnitte : auf d. Grundlage d. neuen DIN 1045. Dusseldorf: Werner-Verlag; 1972.
- [23] DIN [Deutsches Institut für Normung]. *Beton und Stahlbetonbau: Bemessung und Ausführung - DIN 1045*. Berlin: 1972.
- [24] CEB/FIP [Comité Euro-International du Béton / Fédération Internationale de la Précontrainte]. *Manual on Bending and Compression - Design of Sections under Axial Action Effects at the Ultimate Limit State*. London and New York: Construction Press; 1982.
- [25] EPPO [Earthquake Planning and Protection Organization Greece]. *Hellenic Reinforced Concrete Code (EKOS 2000)*. Athens: 2001.
- [26] BS [British Standards Institution]. *BS8110 - Structural use of concrete - Part 3 : Design charts for singly reinforced beams, doubly reinforced beams and rectangular columns*. 1985.

- [27] ACI [American Concrete Institute]. ACI SP-17M(09) : ACI Design Handbook - Design of Structural Reinforced Concrete Elements in Accordance with ACI 318-05. 2010.
- [28] CEN [European Committee for Standardization]. Eurocode 8: Design of structures for earthquake resistance - Part 1: General rules, seismic actions and rules for buildings (EN1998-1). Brussels: 2004.