

Available online at [www.sciencedirect.com](http://www.sciencedirect.com)**ScienceDirect**

Procedia CIRP 10 (2013) 162 – 168

[www.elsevier.com/locate/procedia](http://www.elsevier.com/locate/procedia)

12th CIRP Conference on Computer Aided Tolerancing

## A novel algorithm of posture best fit based on key characteristics for large components assembly

Lianyu Zheng<sup>\*a</sup>, Xusheng Zhu<sup>a</sup>, Renwei Liu<sup>b</sup>, Yiwei Wang<sup>a</sup>, Paul G. Maropoulos<sup>c</sup><sup>a</sup>*School of Mechanical Engineering and Automation, Beihang University, Beijing, 100191, China*<sup>b</sup>*Shanghai Institute of Satellite Engineering, Shanghai, 200240, China*<sup>c</sup>*Department of Mechanical Engineering, University of Bath, Bath, BA2 7AY, UK*

### Abstract

Measurement and variation control of geometrical Key Characteristics (KCs), such as flatness and gap of joint faces, coaxiality of cabin sections, is the crucial issue in large components assembly from the aerospace industry. Aiming to control geometrical KCs and to attain the best fit of posture, an optimization algorithm based on KCs for large components assembly is proposed. This approach regards the posture best fit, which is a key activity in Measurement Aided Assembly (MAA), as a two-phase optimal problem. In the first phase, the global measurement coordinate system of digital model and shop floor is unified with minimum error based on singular value decomposition, and the current posture of components being assembled is optimally solved in terms of minimum variation of all reference points. In the second phase, the best posture of the movable component is optimally determined by minimizing multiple KCs' variation with the constraints that every KC respectively conforms to its product specification. The optimal models and the process procedures for these two-phase optimal problems based on Particle Swarm Optimization (PSO) are proposed. In each model, every posture to be calculated is modeled as a 6 dimensional particle (three movement and three rotation parameters). Finally, an example that two cabin sections of satellite mainframe structure are being assembled is selected to verify the effectiveness of the proposed approach, models and algorithms. The experiment result shows the approach is promising and will provide a foundation for further study and application.

© 2013 The Authors. Published by Elsevier B.V. Open access under [CC BY-NC-ND license](http://creativecommons.org/licenses/by-nc-nd/4.0/).

Selection and peer-review under responsibility of Professor Xiangqian (Jane) Jiang

*Keywords:* Large Volume Metrology (LVM); Measurement Aided Assembly (MAA); Posture; Best Fit; Key Characteristics (KCs).

### 1. Introduction

In recent years, there have been increasing demands on the assembly quality of ever-larger products such as aircrafts, airships, ships and wind turbines. The most crucial issue in large component assembly is the variation control of Key Characteristics (KCs), e.g. docking coaxiality, the assembly hole position, the gap of joint faces, the profile of aerodynamic surface, etc [1]. KCs are a subset of product information, which play a significant role throughout the product lifecycle. For mechanical products, most of the KCs refer to the

geometric characteristics, i.e. geometric dimensions and tolerances as well as roughness [2]. Variation of geometrical KCs in large scale components assembly directly determines the assembly quality and significantly influences the product performance [3]. Therefore, during large components assembly, it is very important to determine and control assembly postures (i.e. position and orientation) of the components and the assembly variation so that the variation of the KCs are within tolerance. With a number of significant technical developments, e.g. the computer aided design and the manufacturing (CAD/CAM) techniques, the optical measurement techniques, etc., this issue will be gradually solved by means of the Large Volume Metrology (LVM) and the Measurement-Assisted Assembly (MAA) [4-6]. However, the model and the

\* Corresponding author. Tel.: 86-10-82317725; fax: 86-10-82317735.

E-mail address: [lyzheng@buaa.edu.cn](mailto:lyzheng@buaa.edu.cn).

algorithm of the best posture fit have not been provided in these studies.

So far existing studies mainly focus on posture adjustment and posture measurement. On one hand, posture adjustment assumes that the best postures are given and concentrates more on developing accurate hardware for MAA, e.g. assembly machine tools and toolings for adjusting large sub-assembly's position and orientation. On the other hand, for posture measurement, there are also a number of research for dynamic objects such as airships and robotics [7-10]. However, these studies mainly focused on the position and orientation measurement for single tracking object, and the proposed methods aimed to reduce posture calculation errors and to realize precise tracking, etc. There is little research on best posture fit method for the components being assembled to meet the final assembly requirements, which are usually defined by KCs in complex product assemblies including two or more subassemblies. Moreover, so far, the optimization criteria for best posture fit are mainly based on the deviations of reference/datum points or single tolerance of the assembly. Such criterion is not robust and comprehensive enough, in it is not easy that the obtained posture to assure the assembly quality.

Consequently, it is necessary to develop a general and robust approach to best posture fit, which is able to cover multiple KCs (i.e. key GD&T), for large components assembly in the context of MAA. This paper focuses on a novel method for best assembly posture fit based on multiple assembly KCs.

## 2. Algorithm description

### 2.1. Assembly process and coordinate system definitions

Large-scale components (e.g. satellite cabins) assembly can be divided into the following steps, as shown in Fig.1. First fixing the reference or the datum components (DC) on the assembly tooling. Second positioning the movable component (MC) in somewhere over the DC by the crane and other assembly tooling. Finally with the help of laser trackers, adjusting the posture of MC to the best assembly posture and finishing the assembly.

In order to describe the algorithm conveniently, some terms and parameters are defined as following:

- Global coordinate system (GCS), which is expressed with  $O-XYZ$  and it is the datum coordinate system of assembly process;
- Measurement coordinate system (MCS) is the default coordinate system And can be expressed with  $O_M-X_M Y_M Z_M$ .
- Local coordinate system (LCS) for the movable components during assembly is expressed with  $O_L-$

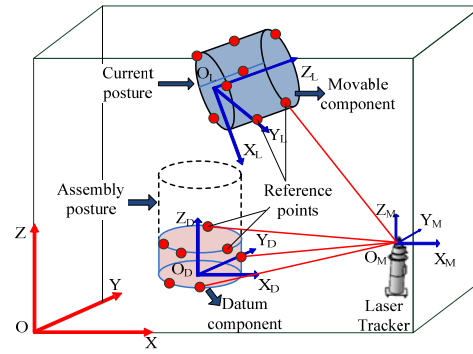

Fig. 1. Illustration of Satellite cabin assembly

$X_L Y_L Z_L$ . It is defined in the digital model of movable component.

- The reference points coordinate value is expressed with the homogenous coordinate,  $(x, y, z, 1)^T$ . According to the function of points, they can be classified into different points groups, and the denomination of points group is as following,

$$\begin{matrix} \text{(CS)} \\ \text{(Type)} \end{matrix} \mathbf{P} = \begin{matrix} \text{(CS)} \\ \text{(Type)} \end{matrix} (\mathbf{P}_1, \mathbf{P}_2 \cdots \mathbf{P}_k) \quad (1)$$

where, k is the number of point in this points group.

The superscript (CS) means the coordinate system that define the coordinate value, e.g. the global coordinate system(G), the local coordinate system (L) and the measurement coordinate system (M), etc. The meaning of the subscript (Type) is the type of the value, whose option is nominal (N) or actual (A). For example,  $\begin{matrix} \text{(G)} \\ \text{(A)} \end{matrix} \mathbf{P}$  represents the actual coordinate in the GCS.

### 2.2. Overview of the algorithm process

This approach regards the posture best fit based on KCs as a two-phase optimal problem, i.e. current posture fit and best posture fit, as shown in figure 2. In the first phase, the current posture of movable component, which is expressed by matrix  $M_C$ , is optimally solved by means of computing the reference point data. And the best assembly posture which can guarantee assembly KCs, is calculated by solving the best posture mathematical model for the second phase.

Before the execution of the fit algorithm, a set of pre-process activities need to be conducted. These activities include:(1)Identify KCs for best fit assembly;(2)Select or define the reference points for best posture fit;(3)Extract the corresponding nominal value of the reference points from digital model;(4) Measure the reference points on the DC and MC.

The 6-DOF parameters ( $T_x, T_y, T_z, \alpha, \beta, \gamma$ ) of rigid-body spatial posture (i.e. position and orientation) can be expressed by the transformation relationship from its local coordinate system to global coordinate system, and

### 3. Current posture fit

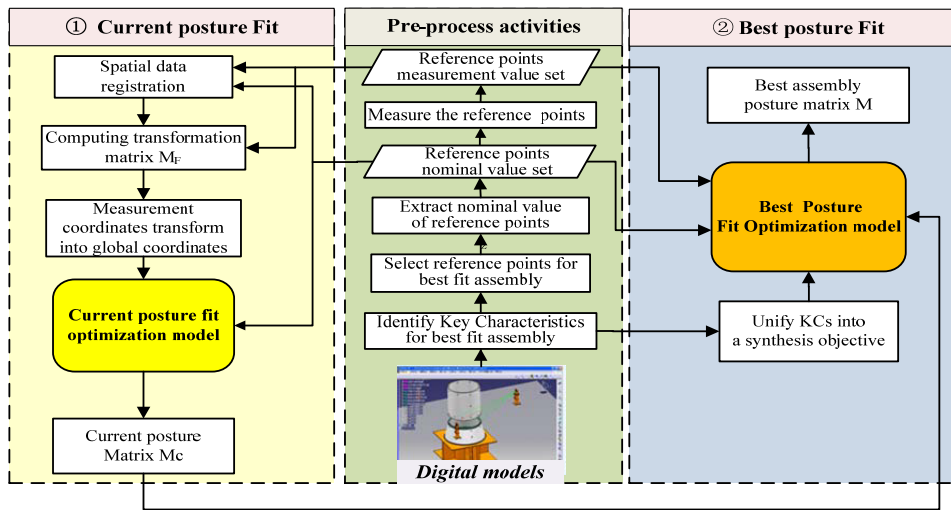

Fig. 2. Algorithm flowchart

the transformation matrix  $M$  is of the form,

$$M_{4 \times 4} = f(T_x, T_y, T_z, \alpha, \beta, \gamma) = \begin{bmatrix} R & T \\ 0 & 1 \end{bmatrix} \quad (2)$$

where,

$$R_{3 \times 3} = \begin{bmatrix} c\gamma c\beta & c\gamma s\beta s\alpha - s\gamma c\alpha & c\gamma s\beta c\alpha + s\gamma s\alpha \\ s\gamma c\beta & s\gamma s\beta s\alpha + c\gamma c\alpha & s\gamma s\beta c\alpha - c\gamma s\alpha \\ -s\beta & c\beta s\alpha & c\beta c\alpha \end{bmatrix} \quad (3)$$

where c and s mean cos and sin, respectively.

$$T_{(3 \times 1)} = (T_x, T_y, T_z)^T \quad (4)$$

Local coordinate  $(x_L, y_L, z_L)^T$  can transform into global coordinate  $(x, y, z, 1)^T$  by following equation,

$$(x, y, z, 1)^T = M \bullet (x_L, y_L, z_L, 1)^T \quad (5)$$

#### 3.1. Spatial data registration

Because the difference between global coordinate system and measurement coordinate system, spatial data registration should be done firstly. The transformation matrix from measurement coordinate to global system is expressed with  $M_F$ .

Theoretically,  $M_F$  can be determined by the measurement coordinates and global coordinates of three reference points which are not in one straight line.

However, in order to improve the registration accuracy and redundancy, five reference points are employed. According to Eq.(5), the global coordinates and the measurement coordinates of the reference points have following relation,

$$\begin{matrix} (G) \\ (N) \end{matrix} P = M_F \bullet \begin{matrix} (M) \\ (N) \end{matrix} P = \begin{bmatrix} R & T \\ 0 & 1 \end{bmatrix} \begin{matrix} (M) \\ (N) \end{matrix} P \quad (6)$$

The gravity center of a group of reference points is unique. According to this principle, the rotation matrix can be computed firstly without considering translation matrix as following steps.

Firstly, computing the global coordinates and the measurement coordinates of the gravity center of the reference points group respectively,

$$\begin{matrix} (G) \\ (N) \end{matrix} \bar{P}_C = \sum \begin{matrix} (G) \\ (N) \end{matrix} P_i / 5, \quad \begin{matrix} (M) \\ (N) \end{matrix} \bar{P}_C = \sum \begin{matrix} (M) \\ (N) \end{matrix} P_i / 5 \quad (7)$$

Then, centralizing the global coordinates and the measurement coordinates to the gravity center,

$$\begin{matrix} (M) \\ (N) \end{matrix} P_C = \begin{matrix} (M) \\ (N) \end{matrix} P - \begin{matrix} (M) \\ (N) \end{matrix} \bar{P}_C = \begin{matrix} (M) \\ (N) \end{matrix} P'_C, 0)^T \quad (8)$$

$$\begin{matrix} (G) \\ (N) \end{matrix} P_C = \begin{matrix} (G) \\ (N) \end{matrix} P - \begin{matrix} (G) \\ (N) \end{matrix} \bar{P}_C = \begin{matrix} (G) \\ (N) \end{matrix} P'_C, 0)^T \quad (9)$$

The Eq.(6) can be written as,

$$\begin{matrix} (G) \\ (N) \end{matrix} P_C = \begin{pmatrix} \begin{matrix} (G) \\ (N) \end{matrix} P'_C \\ 0 \end{pmatrix} = \begin{bmatrix} R_{3 \times 3} & T_{3 \times 1} \\ 0 & 1 \end{bmatrix} \bullet \begin{pmatrix} \begin{matrix} (M) \\ (N) \end{matrix} P'_C \\ 0 \end{pmatrix} = M_F \bullet \begin{matrix} (M) \\ (N) \end{matrix} P_C \quad (10)$$

Therefore,

$${}^{(G)}_{(N)}P'_C = R \bullet {}^{(M)}_{(A)}P'_C \tag{11}$$

Ideally, the nominal value  ${}^{(M)}_{(A)}P$  is equal to the actual value  ${}^{(M)}_{(A)}P'$ , however, there are some errors in measurement and manufacturing. The deviation between the nominal value and the actual value can be given,

$$\varepsilon = (\varepsilon_1, \varepsilon_2, \dots, \varepsilon_k) = {}^{(G)}_{(N)}P'_C - {}^{(G)}_{(A)}P'_C = {}^{(G)}_{(N)}P'_C - R \bullet {}^{(M)}_{(A)}P'_C \tag{12}$$

Aiming to minimize the deviation, an optimization model based on singular value decomposition is proposed,

$$\begin{aligned} \min \left( \sum \left\| {}^{(G)}_{(N)}P'_C - R \bullet {}^{(M)}_{(A)}P'_C \right\|^2 \right) &= \min \\ \left( \sum \left( {}^{(G)}_{(N)}P'_C{}^T {}^{(G)}_{(N)}P'_C + {}^{(M)}_{(A)}P'_C{}^T {}^{(M)}_{(A)}P'_C - 2 {}^{(G)}_{(N)}P'_C{}^T R {}^{(M)}_{(A)}P'_C \right) \right) \\ \Leftrightarrow \max \left( {}^{(G)}_{(N)}P'_C{}^T R {}^{(M)}_{(A)}P'_C \right) &\Leftrightarrow \max(\text{trace}(RH)) \end{aligned} \tag{13}$$

where,

$$H = \sum {}^{(M)}_{(A)}P'_C {}^{(G)}_{(N)}P'_C{}^T \tag{13}$$

According to the theory of matrices, the singular value decomposition(SVD) of  $H$  is,

$$H = Q^T AV \tag{14}$$

where, both  $Q$  and  $V$  are orthogonal matrices. The optimal value of  $R$  can be given,

$$R = V^T Q \tag{15}$$

Then, the translation vector is,

$$T = {}^{(G)}_{(N)}P - R {}^{(M)}_{(A)}P \tag{16}$$

### 3.2. Current posture fit

In the first phase, the correlation between two different coordinate systems can be founded by evaluating the relationship between the global coordinate value and the local coordinate value of a serial reference points. The current posture can be represented by the transformation matrix  $M_C$  which satisfies following formula,

$${}^{(G)}_{(A)}P = M_{C(A)} {}^{(L)}_{(N)}P \tag{17}$$

The value of  ${}^{(L)}_{(A)}P$  can be instead by  ${}^{(L)}_{(N)}P$  in ideal condition. Actually, because of manufacturing and

measuring errors, any actual coordinate incorporates a deviation from the nominal value, which can be expressed as a residual error, as shown in Eq. (16).

$$\varepsilon = {}^{(G)}_{(A)}P - M_{C(N)} {}^{(L)}_{(N)}P \tag{18}$$

Then, the mathematic optimization model can be established,

$$\begin{aligned} \min \left( \sum (\varepsilon_{ix}^2 + \varepsilon_{iy}^2 + \varepsilon_{iz}^2) \right) &\Leftrightarrow \min \|\varepsilon\|_F^2 = \\ \min(\text{trace}(\varepsilon^T \varepsilon)) &\end{aligned} \tag{19}$$

and  $\varepsilon_i$  must apply the following threshold constraint,

$$\varepsilon_{lower} \leq \varepsilon_i \leq \varepsilon_{upper}, \quad i = 1, 2, 3, \dots \tag{20}$$

where,  $\varepsilon_{lower}$  and  $\varepsilon_{upper}$  represent the lower and the upper allowable deviation respectively.

## 4. Best posture fit

### 4.1. Mathematic model

Aiming to control assembly quality, the best assembly posture that can guarantee assembly KCs, must be given. In the actual assembly, there are multiple GD&T requirements, and their units are not uniform. This paper put these GD&T as the optimization multiple-objectives, and they can be unified by means of synthetic error which is used to evaluate the assembly quality. The synthetic error can be computed as following steps:

- The importance degree of GD&T is classified into 10 grades  $W = \{1, 2, \dots, 10\}$ ;
- According to influence of each KCs deviation upon overall performance, determining its corresponding weight  $W_i$ ;
- Assuming the error of the  $i$ th KC is  $\varepsilon_i$ , and the synthetic error  $E$  can be given as,

$$E = \sum W_i \varepsilon_i / \sum W_i \tag{21}$$

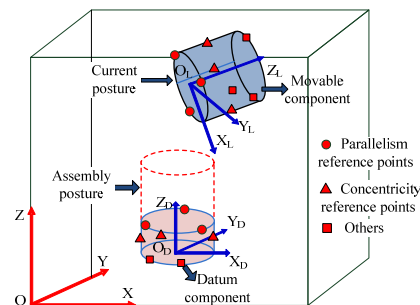

Fig. 3. Best posture fit

As shown in Fig.3, form & position error computation formula can be given by means of the relationship between reference points coordinate of movable component and datum component.

The form & position error can be evaluated using the coordinate of reference points on datum component and on movable component. So,  $\varepsilon_i$  can be computed by following formula,

$$\varepsilon_i = f_i \left( \begin{matrix} (G) \\ (A) \end{matrix} P_{ID}, \begin{matrix} (G) \\ (A) \end{matrix} P_{IM} \right) \quad (22)$$

where  $\begin{matrix} (G) \\ (A) \end{matrix} P_{ID}$  and  $\begin{matrix} (G) \\ (A) \end{matrix} P_{IM}$  are coordinates of the reference points to evaluate  $i$ th form& position error on DC and MC respectively.  $f_i$  is the evaluation algorithm for  $i$ th form& position error given in literature.

To the reference points on MC, global coordinates  $\begin{matrix} (G) \\ (A) \end{matrix} P_{IM}$  are different in accordance with different posture, but the local coordinates are constant.

$$\begin{matrix} (L) \\ (A) \end{matrix} P_{IM} = M_C^{-1} \bullet \begin{matrix} (G) \\ (A) \end{matrix} P_{IM-Mc} \quad (23)$$

Where,  $\begin{matrix} (G) \\ (A) \end{matrix} P_{IM-Mc}$  are the reference point coordinates on MC at the initial posture ( $M_C$ ).When the movable component at the posture  $M$ , the coordinates of reference points on MC can be given,

$$\begin{matrix} (G) \\ (A) \end{matrix} P_{IM} = M \bullet \begin{matrix} (L) \\ (A) \end{matrix} P_{IM} = M \bullet M_C^{-1} \begin{matrix} (G) \\ (A) \end{matrix} P_{IM-Mc} \quad (24)$$

$$\varepsilon_i = f_i \left( \begin{matrix} (G) \\ (A) \end{matrix} P_{ID}, \begin{matrix} (G) \\ (A) \end{matrix} P_{IM} \right) = f_i \left( \begin{matrix} (G) \\ (A) \end{matrix} P_{ID}, MM_C^{-1} \begin{matrix} (G) \\ (A) \end{matrix} P_{IM-Mc} \right) \quad (25)$$

The best assembly posture can be expressed as the minimum synthetic error,

$$\min(E) = \min \left\{ \sum W_i f_i \left( \begin{matrix} (G) \\ (A) \end{matrix} P_{ID}, MM_C^{-1} \begin{matrix} (G) \\ (A) \end{matrix} P_{IM-Mc} \right) / \sum W_i \right\} \quad (26)$$

And  $\varepsilon_i$  apply the following threshold constraints:

$$E_{I-lower} < \varepsilon_i < E_{I-upper} \quad (27)$$

$E_{I-lower}$  and  $E_{I-upper}$  represent the lower and the upper allowable deviation of the  $i$ th KC respectively.

#### 4.2. The solving process using PSO

This paper proposes the optimal models and the process procedures for the two problems based on (PSO) [11]. The main steps of PSO, which are shown in Fig. 4.

- In the proposed model, every feasible posture of a component during assembly is modeled as a 6 dimensional particle. Each particle keeps track of its coordinates in the problem space which are associated with the best solution(fitness) it has achieved so far. This value is called *pbest*. Another “best” value that is tracked by the global version of the particle swarm optimizer is the overall best value, and its location, obtained so far by any particle in the population. This location is called *gbest*.
- Using PSO to compute the degree of fitness, then *pbest* and *gbest* can be achieved. In each iteration, particle updates its own velocity and position according to *pbest* and *gbest*.
- Keeping on searching *pbest* and *gbest* according to updated particles, until conditions of terminating iteration is met.
- Finally, the current posture ( $M_C$ ) and the best assembly posture ( $M$ ) can be achieved.

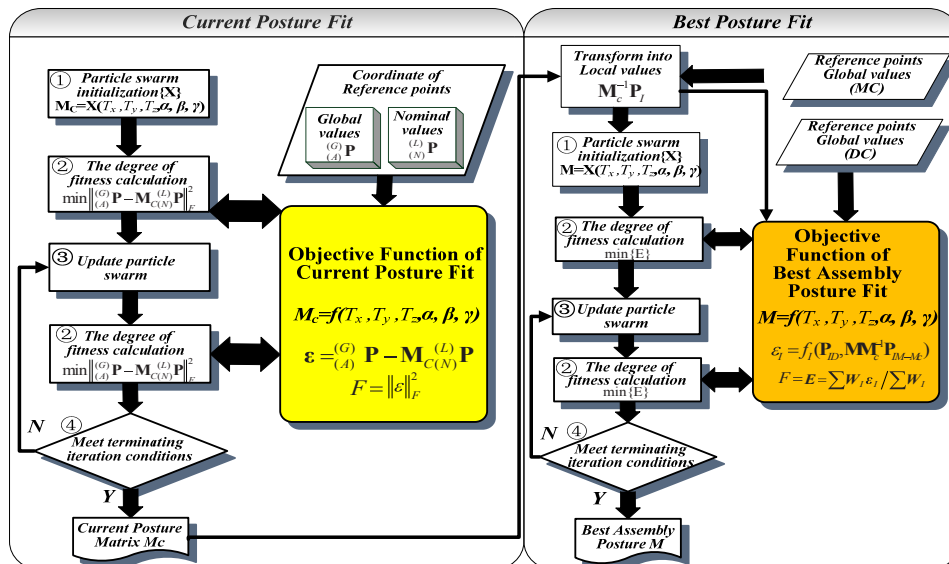

Fig. 4. The algorithm process based on PSO

5. Implementation and simulation experiments

The proposed two-phase posture fit algorithm for the MAA for large components assembly has been implemented by a prototype-Integrated Large Volume Metrology System (ILVMS) [12], which is an add-in software tool integrated in the CATIA system, as shown in Fig.5.

An assembly example about two cabin sections joining of satellite mainframe structure is selected to verify the effectiveness of the proposed approach, models and process algorithms. More specifically, the datum component (A) has been fixed in assembly tooling, and the task of this algorithm is to fit the best posture of the movable component (B).The GD&T requirements are shown in table 1.

This experiment used API-T3 laser tracker to measure reference points. The capability of the laser tracker is 10ppm ( $\sigma_l$ ) in length measurement, and about 1" ( $\sigma_\alpha=\sigma_\beta$ ) in angles measurement. Three measurement stations were used, as shown in Fig.5, because some of the reference points to be measured cannot be accessed if using one measurement station. After data fusion [13], reference points coordinates are shown in table 2.

The best assembly posture computation of the movable component performs as following steps:

- First step, as we can see in figure 6, is computing the current posture of B, according to data of table 2. And the 6-DOF parameters of the current posture fit is shown in table 3.
- Second step is fitting the best assembly posture, as shown Fig.6. The iterator terminates when B at located of the best posture in table 3. This is the best assembly posture of the movable cabin (B). Table 4 reports that best assembly posture satisfies the requirements of the three GD&Ts.

In actual assembly, the best assembly posture can be achieved through many discrete steps by real-time tracking of posture measurement, data fitting and posture readjustment.

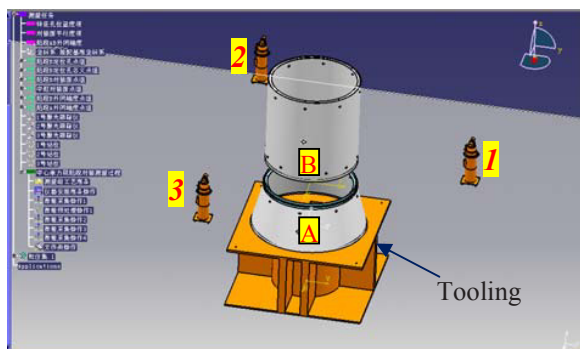

Fig. 5. Measurement virtual simulation

Table 1. Parameter of inspection items (Key characteristics, KCs)

Measurement items	Tolerance		Feature	Weighing coefficient ( $W_i$ )
	Upper /mm	Lower /mm		
Parallelism	0.2	0	Binding surface of A, B	9
Position	0.2	0	Axis of location hole on B	9
Concentricity	0.8	0	External surface of A&B	9
Synthesis	0.4	0	---	---

Table 2. Reference points data of movable component (B)

Reference Points	Local nominal values			Global actual values		
	X <sub>0</sub> /mm	Y <sub>0</sub> /mm	Z <sub>0</sub> /mm	X /mm	Y /mm	Z /mm
P1	605	0	120	953.013	275.061	1969.986
P2	0	605	120	347.993	879.936	1969.917
P3	-605	0	120	257.035	275.014	1969.973
P4	0	-605	120	347.933	329.946	1969.964
P5	605	0	1100	952.999	275.000	2949.988
P6	0	605	1100	348.020	879.987	2949.917
P7	-605	0	1100	257.051	275.012	2949.937
P8	0	-605	1100	347.983	330.047	2949.941

Table 3. Posture parameters

T <sub>x</sub> (mm)	T <sub>y</sub> (mm)	T <sub>z</sub> (mm)	$\alpha$ (rad)	$\beta$ (rad)	$\gamma$ (rad)
(1)347.967	275.001	1850.002	-0.0030367	-0.004010	-0.00057296
(2)-0.0085480	0.0304941	1490	-0.0020628	-0.0034377	-0.0034377

(1): Current posture; (2):Best assembly posture

Table 4. Inspection items error

Inspection items	Position (mm)	Parallelism (mm)	Concentricity (mm)
Deviation	0.184	0.156	0.129
Within tolerance?	Yes	Yes	Yes

6. Concluding remarks

A novel algorithm for best assembly posture fit based on KCs for large components assembly is presented and verified through simulation experimental testing. In terms of the spatial registration based on SVD, the process of computation can be simplified and the precision of the current posture fit can be improved. Using the synthetic error, which is determined according to importance of each KCs to overall performance, as the optimization objective to fit the best assembly posture, can guarantee the overall assembly quality. The results of simulation experiment show that the proposed algorithm is effective to control assembly quality. The proposed approach is general and robust and can be used in all large-scale components assembly, e.g. fuselage,

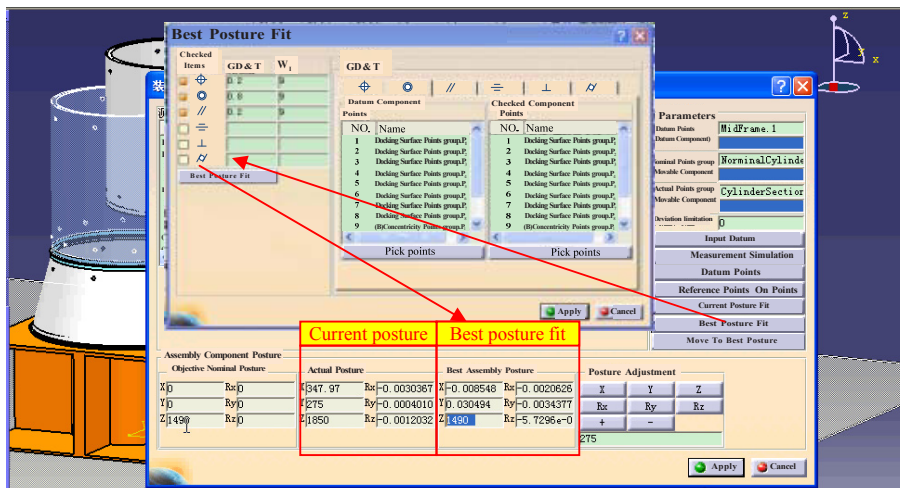

Fig. 6. Current & best assembly posture fit

spacecraft cabin etc. For specific assembly tasks, just the key GD&Ts or KCs, reference points and their limit constraints, need to be identified and provided.

### Acknowledgement

The authors acknowledge the financial support of National Natural Science Foundation of China (No.51175026) and Beijing Key Laboratory of Digital Design and Manufacturing.

### Reference

- [1] Thornton AC, 2004. Variation Risk Management: Focusing quality improvements in product development and production. John Wiley and Sons, New Jersey.
- [2] Zheng LY, McMahon CA, Li L, Ding L, Jamshidi J, 2008. Key characteristics management in product lifecycle management: a survey of methodologies and practices. Proc of the IMechE, Part B: Journal of Engineering Manufacture, 222:989-1008.
- [3] Johan SC, 2000. How to reduce geometrical variation in assembled products. Doctoral Thesis, Chalmers University of Technology and Goteborg University, Sweden.
- [4] Benoit M, Bernard R, 2003. Measurement-assisted assembly applications on airbus final assembly line. SAE Technical Paper Series, 2003-01-2950.
- [5] Jamshidi J, Kayani A, Irvani P, Maropoulos PG, 2010. Manufacturing and assembly automation by integrated metrology systems for aircraft wing fabrication. Proc of the IMechE, Part B: Journal of Engineering Manufacture, 224:25-36.
- [6] Maropoulos PG, Vichare P, Martin O, Muelaner J, Summers MD, Kayani A, 2011. Early design verification of complex assembly variability using a Hybrid-Model Based and Physical Testing – Methodology. CIRP Annals-Manufacturing Technology, 60:207-210.
- [7] Beutler F, Hanebeck UD, 2005. Closed-form range-based posture estimation based on decoupling translation and orientation.

Proceeding of 2005 IEEE International Conference on Acoustics, Speech, and Signal Processing, Pennsylvania, PA, USA: IEEE Press, p.989-992.

- [8] Vincze M, Prenninger JP, Gander H, 1994. A laser tracking system to measure position and orientation of robot end effectors under motion. The International Journal of Robotics Research, 13:305-314.
- [9] Edouard L, Shingo K, 2009. Dynamical Models for Position Measurement with Global Shutter and Rolling Shutter Cameras. Proceeding of the 2009 IEEE/RJS International Conference on Intelligent Robots and Systems, St. Louis: IEEE Press, 5204 – 5209.
- [10] Hiroyuki M, Toshihiko T, 2003. A three dimensional position measurement method using two pan-tilt cameras. R&D Review of Toyota CRDL, 38:43-48.
- [11] Eberhart RC, Shi YH, 2001. Particle swarm optimization: developments, applications and resources. Proceeding of Congress on Evolutionary Computation, Piscataway, New Jersey: IEEE Press, p.81-86.
- [12] Zheng LY, Yang FL, Ni AJ, 2009. A general framework of measurement system configuration for large and complex components. Proceedings of the 6th CIRP-Sponsored International Conference on Digital Enterprise Technology-Advances in Intelligent and Soft Computing, Hong Kong: Springer, p.983-997.
- [13] Weckenmann A, Jiang X, Sommer KD, Rube UN, Seewig J, Shaw L, et al, 2009. Multisensor data fusion in dimensional metrology. CIRP Annals-Manufacturing Technology, 58:701-721.