

Available online at www.sciencedirect.com
ScienceDirect

Procedia CIRP 25 (2014) 19 – 26

www.elsevier.com/locate/procedia

8th International Conference on Digital Enterprise Technology - DET 2014 – “Disruptive Innovation in Manufacturing Engineering towards the 4th Industrial Revolution”

An exploration into measurement consistency on coordinate measuring machines

Per Saunders^{a,b,*}, Alan Wilson^c, Nick Orchard^d, Neil Tatman^d, Paul Maropoulos^a

^aDepartment of Mechanical Engineering, University of Bath, BA2 7AY, UK

^bNational Composites Centre, Bristol and Bath Science Park, Bristol, BS16 7FS, UK

^cNational Physical Laboratory, Teddington, Middlesex, TW11 0LW, UK

^dManufacturing Technology, Rolls-Royce plc, Derby, DE24 8BJ, UK

* Corresponding author. Tel.: +44-117-370-7676 E-mail address: p.c.h.saunders@bath.ac.uk

Abstract

In high precision industry, the measurement of geometry is often performed using coordinate measuring machines (CMMs). Measurements on CMMs can occur at many places within a long and global supply chain. In this context it is a challenge to control consistency, so that measurements are applied with appropriate levels of rigour and achieve comparable results, wherever and whenever they are performed. In this paper, a framework is outlined in which consistency is controlled through measurement strategy, such as the number and location of measurement points. The framework is put to action in a case study, demonstrating the usefulness of the approach and highlighting the dangers of imposing rigid measurement strategies across the supply chain, even if linked to standardised manufacturing processes. Potential mitigations, and the requirements for future research, are outlined.

© 2014 Published by Elsevier B.V. This is an open access article under the CC BY-NC-ND license (<http://creativecommons.org/licenses/by-nc-nd/3.0/>).

Peer-review under responsibility of The International Scientific Committee of the 8th International Conference on Digital Enterprise Technology - DET 2014 – “Disruptive Innovation in Manufacturing Engineering towards the 4th Industrial Revolution”

Keywords: Uncertainty; CMM; Simulation

1. Introduction

A complex engineering product, such as a gas turbine engine, can comprise tens of thousands of unique components. The components may be made across many sites throughout the globe, and by numerous suppliers, before being brought together as a single final assembly. At the same time, there is a need to develop technical deliverables, such as fixtures, tooling, machine set-ups, and tool paths, concurrently in order to meet the challenging targets that the business demands.

This challenge is partly addressed by integrating product definition and process development activities into systems that are now known as product lifecycle management (PLM). In state of the art solutions, the entire method of manufacture can be planned and fully associated to 3D design models through PLM. When methods are embodied within PLM, re-use is encouraged and improvements can be cascaded all the way through the supply chain [1].

The measurement of geometry, that is to say the size and shape of components, is fundamental in manufacturing. One might therefore expect measurement to be an integral part of the method of manufacture that is developed in PLM. However, it has been observed that despite the success of integrating seemingly more complex machining processes, many measurement activities still occur in relative isolation of PLM [2].

In this paper an exploration is made into a perennial problem in measurement which the authors believe could be addressed through better integration of measurement with PLM: How can consistency in measurement be controlled, wherever measurement service providers might be located in the supply chain? Two important elements of consistency are as follows:

- consistent results, and
- consistent rigour.

Without systems to help control measurement consistency, one may enter unhelpful debates as to which answer is correct, or one may encounter disproportionately different costs for similar tasks.

For this exploratory study, the authors have chosen to focus on coordinate measuring machines (CMMs) because they are a dominant technology in high precision manufacturing environments. CMMs are often chosen because they are versatile, but it is this very versatility that makes them a potential source of inconsistency [3]. In Section 2, a definition of measurement consistency is developed, and the relationship between measurement consistency and measurement uncertainty is highlighted. In Sections 3 and 4, the available techniques for uncertainty evaluation are considered, together with the importance of measurement strategy in that context. Finally, in the remaining sections, a framework for controlling measurement consistency is described, and the results of an exploratory case study are presented and discussed.

2. Measurement consistency

2.1. Sources of inconsistency

A dictionary definition of ‘consistency’ is ‘constant adherence to the same principles of thought or action’ [4]. Whilst this definition is intended to refer to a personal characteristic, it also works well within the context of measurement when one considers that in programming, operating, and evaluating the measured points that a CMM acquires, many personal choices are made. Three primary considerations are listed below.

- What probing configuration will be selected? For a contact probing system, there could be differences in the selected ball size and material, stylus length and stiffness, extensions, and orientation. It has been shown that parameters such as these can have a significant effect on the measured values that will be reported [5].
- What measurement strategy will be employed? The number and location of measurement points or scan paths are critical decisions [6], though may often be chosen according to individual preference.
- What fitting algorithms will be selected to evaluate the measurand? The latest standards used to specify geometrical requirements provide the facility to specify the fitting algorithms that should be used (e.g. least squares, maximum inscribed, or minimum circumscribed modifiers can be associated with the specification of a circle [7]). It remains to be seen how widely these standards will be taken up; in the meantime, different CMM programmers may select different algorithms.

There are many other factors, including decisions around how a part is oriented and aligned, the distance, speed and direction of approach, and the probing force applied [8]. There are also a large number of factors that may not lie in direct control of the CMM programmer, falling more into the realms of generic good practice. Some of the questions one might want to ask include the following:

- What are the environmental conditions of the CMM? Some CMMs may be located in relatively hostile shop floor environments where temperature may vary significantly between, or even during, measurements;
- What is the condition of the part? The temperature of the part may not have stabilised following a machining operation, or it may need to be cleaned;
- How well are operator procedures followed? If the CMM operator is given inadequate instruction, errors could arise when, for example, presenting a part to its fixture.

Given the large number of variables, it is unreasonable to expect identical results when performing measurements on different CMMs in different environments. However, for multiple results to be useful, they should be consistent – they should adhere to the same principles. In order for this to be possible, the concept of measurement uncertainty can be employed.

2.2. Consistent results

The ‘true’ value of a quantity being measured - the measurand – can never be known; however, the level of confidence in a measured value can be indicated through measurement uncertainty. Uncertainty is defined in the *International vocabulary of metrology* (VIM) as a ‘non-negative parameter characterizing the dispersion of the quantity values being attributed to a measurand, based on the information used’ [9].

The VIM also notes that measurement results include ‘relevant information’, which is often a measurement uncertainty. In fact, according to the VIM, measurement uncertainty should only be excluded from the results when it is considered negligible for the purpose of the measurement.

One can return to the VIM once more to find a definition of metrological ‘compatibility’ as a means of establishing whether two measurement results refer to the same measurand. Measurement uncertainty can be applied as a test of compatibility, by examining whether two measured values are within an agreed multiple of the standard uncertainty.

The VIM’s definition of compatibility is a good starting point for the requirement for consistent results from different CMM systems, although there is a need to account for the fact that when using multiple systems there will be multiple uncertainties. For consistent results, one could require that the uncertainty achieved is similar across all the CMM systems being used for any given measurand.

2.3. Consistent rigour

In order to fully satisfy the desire for consistency, rigour also needs to be addressed. In common with the definition of consistent results, it should not be inferred that the level of rigour applied to measurement, and hence the cost, should be identical across the supply chain. Rather, it should be appropriate, so that in every case the measurement process is ‘just right’ with the resources that are available.

The aim should be to ensure that the measurement uncertainty achieved for each measurand is compatible with

the purpose of the measurement. If the uncertainty associated with a measurement is too high, then the measurement may add no value. In an extreme case, one would not choose to use, say, a steel rule to verify a length dimension that has a tolerance of 50 μm . Conversely, if the uncertainty is unnecessarily low, one should look to see if there could be cost savings by diverting measurement resource to other activities. Again, measurement uncertainty can act as a guide to achieving consistent rigour, and ideally the uncertainty associated with every measurand would be known.

In the next section, the techniques available to evaluate uncertainty are considered. This is followed up in the subsequent section by exploring how uncertainty can then be manipulated on CMMs in order to control consistency.

3. Measurement uncertainty evaluation

Three techniques for evaluating measurement uncertainty on CMMs are outlined in ISO 15530-1 [10]; they may be used singly or in combination. The first of these is known as sensitivity analysis and is described in the ISO *Guide to the Expression of Uncertainty in Measurement* (GUM) [11]. The approach requires a comprehensive understanding of the uncertainty sources and a suitable mathematical model; it is rigorous, though hard to achieve in all but the most simple cases [12]. The second technique is a comparative approach that involves the use of a comparable artefact to capture uncertainty sources and interactions [13]; it is regarded as rigorous and defensible, though can be costly as it relies on the existence of an artefact, the availability of a more capable measurement system, and the ability to meet similarity conditions [12]. The third technique is to use Monte Carlo based simulation known as uncertainty evaluating software (UES) [14], and may be the only practicable option when there are many measurands to assess and predictions are required; as would be the case if one wishes to plan for measurement consistency across a variety of CMMs throughout a product lifecycle. It is unlikely that simulation can adequately cover all uncertainty sources, so it is advisable to use it in combination with other techniques [3].

The relative merits of these three techniques are discussed in Baldwin et al. [15], who referred to an earlier draft of ISO 15530-1 where they note that two further options are discussed - measurement history, and expert judgement. These techniques appear to have been de-emphasised in the latest released version, yet they may have an important place within a PLM context where historical records and expert opinion could be systematically captured and used. Moreover, future revisions of the GUM are expected to extend the use of the Bayesian approach [16], lending support to the idea of using multiple uncertainty evaluation techniques, so long as they improve the current state of knowledge.

4. Measurement uncertainty manipulation

Most of the sources of inconsistency that were highlighted in Section 2.1 are more typically known as uncertainty contributors and should be considered during measurement uncertainty evaluation. The exception would be those sources

that could be labelled as ‘blunders’, such as the example of incorrectly locating a part in its fixture – such issues should be dealt with through standard process control techniques and are outside the scope of this research. Of the remaining factors that were highlighted, there is one which stands out as both conceptually easy to control, and has a high influence on uncertainty – the ‘measurement strategy’.

Measurement strategy is a convenient lever for measurement uncertainty, as it enables uncertainty to be changed through a mechanism that typically has a strong relationship with cost [17]. For a CMM that uses a touch-sensitive probe to take discrete point measurements, the main components of the measurement strategy are the number and placement of the points. Typically, one would expect more points to reduce uncertainty. However, the position of those points is also significant because the optimal measurement strategy is highly dependent on form [18]. Accordingly, strategies can be categorised according to the importance they place on the actual geometry produced [19], as described in the subsections below.

4.1. Blind

Blind strategies aim for a uniform coverage according to rules based on the nominal geometry of the feature being measured [20]. These strategies are labelled ‘blind’, because they are only aware of the geometry specified by design; they take no account of deviations from nominal that are introduced in manufacturing.

4.2. Expert

A small number of knowledge-based systems have been devised that attempt to capture the knowledge of experts (e.g. [21]). This may include knowledge of the manufacturing process. However, given the large number of variables involved, doubts have been raised as to whether the information captured can ever suffice [22].

4.3. Adaptive

The trend is towards strategies that adapt to real geometry. Innovative approaches that alter the strategy dynamically, using prior measurements to drive the choice of the next point, are promising [23]. However there are unresolved technical difficulties, for example in avoiding collisions. A related adaptive approach is to study the manufacturing process and characterise its ‘signature’ [22]. The signature is used to develop a model of the real feature that was produced. Measurement strategies are then devised based on this model of the real feature.

5. Framework for controlling consistency

Common practice for designing the measurement strategy is to make use of the advice in *CMM Measurement Strategies* [24]. This guide is issued by the National Physical Laboratory, the guardians of measurement standards in the UK, and this particular publication is widely used

internationally. Whilst the majority of the document is devoted to blind strategies, the guide advises that it is better to develop an adaptive strategy, based on an analysis of the manufacturing process signature, labelling the two approaches as ‘ad hoc’ and ‘scientific’ respectively. The scientific

could be enhanced by considering it within a PLM context.

A theoretical framework that shows how the scientific method could be implemented as a means to control functional domains which are described in the subsections below.

5.1. Traditional metrology

In some important respects, the scientific approach is not very different from the way metrologists perform their craft today. Metrologists begin by determining requirements: which characteristics and what level of uncertainty is acceptable. Next, they create and execute a program to perform a detailed measurement, in order to acquire a representation of the real geometry. Based on this information, they use their expertise to develop a program to be used by CMM operators in production. This program will use a subset of points from the detailed measurement; in essence, they define an appropriate measurement strategy for each measurand.

5.2. Digital metrology

PLM provides the opportunity to inject structure into the job of the metrologist, integrating tools that allow candidate measurement strategies to be tested on digital models. If a feature can be synthesised following a detailed measurement, various strategies can be tested against the model to determine which ones achieve a target uncertainty level for least cost (for example, by taking a small number of points).

5.3. Measurement operations

Finally, there are a number of automated programming packages that offer ways of implementing the measurement strategies. By using standard programming interfaces, they provide the mechanism by which measurement strategies can be deployed on a variety of machines. However, a challenge remains in validating the success of the operations strategy; will it be sufficiently robust to spot change in manufacturing output? This is the subject of the case study outlined in the next section.

6. Case study

In the case study, an attempt is made to follow the process shown in the framework, investigating the ability of an operations strategy to spot changes in manufacturing output.

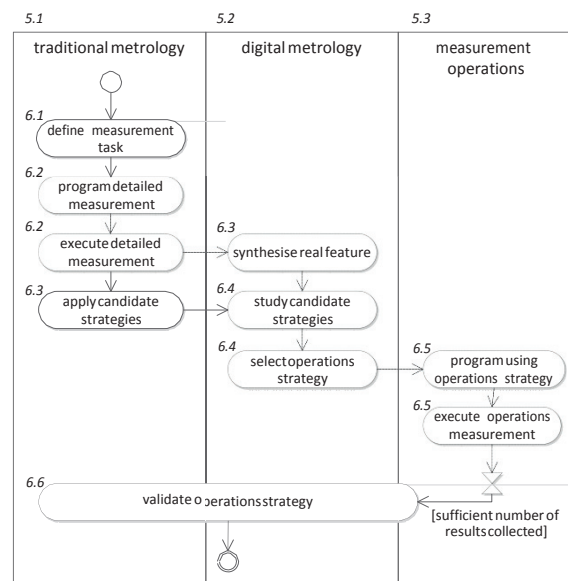


Fig. 1. Activity diagram for controlling measurement consistency.

6.1. Define measurement task

The study is centred on two artefacts that were manufactured with deliberate form errors [25] – these will be referred to as Blocks A and B. The form errors are present on the holes and central boss, as illustrated in Figure 2 and described in Table 1. Cylindricity was selected as the geometric tolerance to evaluate because it is expected to be particularly sensitive to measurement strategy.

Two CMM systems were employed: One for the ‘detailed measurement’; the other for the ‘operations measurement’. Key parameters of these systems are listed in Table 2; the maximum permissible error (MPE) and probe errors were obtained from VDI/VDE 2617 and ISO 10360 performance tests for the respective CMMs. Both systems were used in discrete point mode.

6.2. Program and execute detailed measurement

The detailed measurement was performed on a Zeiss F25 CMM [26]; it was programmed using Calypso software [27]. The blocks were aligned using seventy-eight points to construct the top plane (datum A), twenty points for a line on a side plane (datum B), and one hundred and twenty-eight points to obtain the centre point of hole 5 (datum C). Hole 5 was selected as a datum because it had no deliberate form error. The boss and the holes were measured using sixty-four points at four levels (256 points in total).

The measurements were repeated twelve times in two different orientations to give a mean and standard deviation for cylindricity, as evaluated using Calypso’s Chebyshev minimum zone algorithm. The standard deviation was found to be 0.1 μm or less for all seven features on both of the blocks; consequently the measurements were considered to be sufficiently repeatable to allow further analysis based solely on the mean.

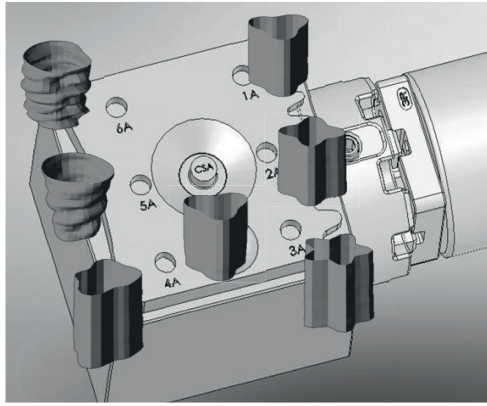


Fig. 2. Block A and representation of form.

Table 1. Form error on the blocks.

Feature	Block A	Block B
Hole 1	3 lobes / 15 μm amplitude	3 lobes / 10 μm amplitude
Hole 2	4 lobes / 15 μm amplitude	4 lobes / 20 μm amplitude
Hole 3	5 lobes / 15 μm amplitude	5 lobes / 25 μm amplitude
Hole 4	5 harmonics \sim 22 μm	3 harmonics \sim 22 μm
Hole 5	No deliberate errors	No deliberate errors
Hole 6	No deliberate errors	No deliberate errors
Boss	3 lobes / 25 μm amplitude	No deliberate errors

Table 2. CMM systems.

	Detailed	Operations
CMM	Zeiss F25	Zeiss UPMC 550
MPE (1D for UPMC)	0.25 μm + L/666	0.9 μm + L/300
Probe error	\sim 0.25 μm	\sim 0.6 μm
Temperature range	20 $^{\circ}\text{C}$ +/- 0.05 $^{\circ}\text{C}$	20 $^{\circ}\text{C}$ +/- 0.1 $^{\circ}\text{C}$
Strategy	256 points (64 @ 4 levels)	32 points (8 @ 4 levels)

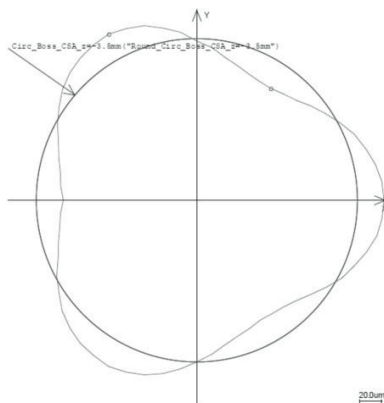


Fig. 3. Plot showing 25 μm amplitude 3-lobe form error on boss.

6.3. Synthesise real feature and apply candidate strategies

The measured points from one of the measurement runs were plotted in order to visually confirm the manufacturing signature according to Table 1. The plots correlated well with measurements that had been made previously using a similar measuring environment at a different location and time [25]. An example of the results achieved at one of the four levels for the central boss on Block A is shown in Figure 3.

Metrosage Pundit/CMM v4 was selected as the UES because it has the ability to model form error [15]. The form was described for each feature through the user interface. Relevant performance parameters for the operations environment were also input to the UES, along with details of the less rigorous measurement strategy of eight points at four levels for feature measurement, as outlined in Table 2. The alignment strategy remained unchanged.

6.4. Study candidate strategies and select operations strategy

The UES showed that there would be a ‘penalty’ for this reduced strategy in the operations environment of between 1 μm and 1.6 μm for each feature; the penalty is the increase in measurement uncertainty associated with the operations strategy and CMM system (for an example, see Fig. 4). Assuming a cylindricity tolerance of 20 μm , and a 10:1 ratio between the tolerance and an acceptable increase in uncertainty, this might be deemed to be a reasonable price for measurement on a less costly system.

6.5. Program and execute operations measurement

Next, the operations measurement was performed using a program that was developed in Calypso; it was executed ten times in two orientations. On analyzing the results, it was found that there were two instances where the standard deviation reached 0.5 μm and 0.3 μm (Hole 5A and 3B respectively); for all other cases, the standard deviation was less than 0.2 μm , providing confidence in the repeatability of the system.

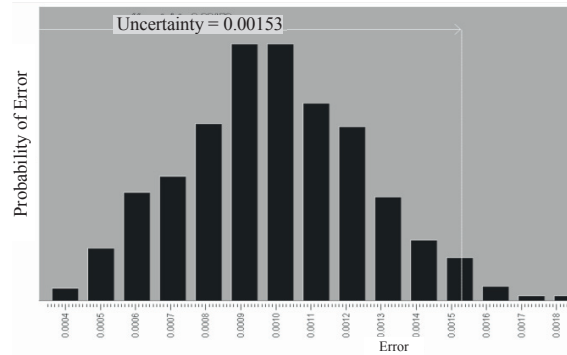


Fig. 4. Uncertainty associated with the operations measurement showing measurement uncertainty as determined by UES along with the associated probability distribution.

Table 3. Percentage of form captured.

	Block A			Block B		
	$\gamma^{DE} / \mu\text{m}$	$\gamma^{OP} / \mu\text{m}$	η ($\gamma^{OP} / \gamma^{DE}$)	$\gamma^{DE} / \mu\text{m}$	$\gamma^{OP} / \mu\text{m}$	η ($\gamma^{OP} / \gamma^{DE}$)
Hole 1	32.8	25.3	0.77	19.9	17.2	0.86
Hole 2	32.5	33.5	1.03	41.3	41.3	1.00
Hole 3	34.8	26.0	0.75	49.9	41.8	0.84
Hole 4	35.8	27.0	0.75	31.4	24.3	0.78
Hole 5	7.1	5.0	0.70	4.4	4.2	0.97
Hole 6	2.1	2.1	1.00	4.7	4.0	0.84
Boss	52.0	48.8	0.94	1.9	2.5	1.30

Key:

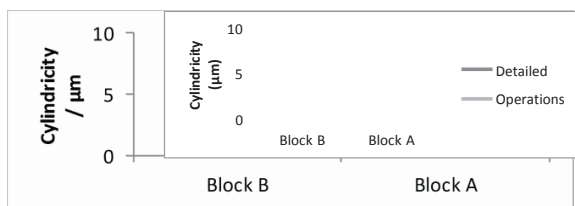
 γ^{DE} Cylindricity from Zeiss F25 measurements ('Detailed') γ^{OP} Cylindricity from Zeiss UPMC measurements ('Operations') η Proportion cylindricity captured in Operations compared to Detailed

Fig. 5. Hole 5 ('no deliberate errors' on either block).

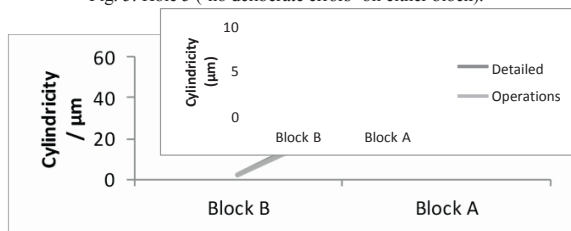


Fig. 6. Boss (from 'no deliberate errors' to 3 lobe / 25 μm).

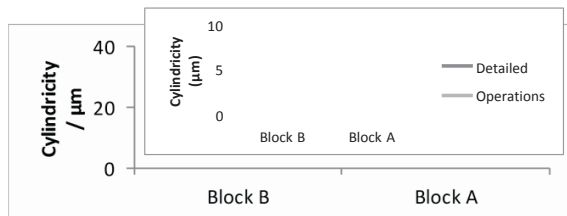


Fig. 7. Hole 1 (3 lobe hole – from 10 μm amplitude to 15 μm).

6.6. Validate operations strategy

The Calypso software for the UPMC was equipped with a virtual CMM (VCMM) [28], so the program was also run in VCMM mode; the VCMM reported a maximum uncertainty of 0.2 μm. The small number reflects the fact that this VCMM does not model form error, and provides further support for the thinking that the interaction between form and strategy is likely to be a major source of any major differences in cylindricity between the two systems.

Table 3 lists the mean cylindricity calculated for each feature from the detailed and operations measurements.

The parameter η is an indication of how much form was captured by the operations measurement as compared with the detailed measurement.

7. Discussion

7.1. Relationship between form and measurement strategy

In general, the results in Table 3 validate the theory that by taking fewer measurement points, less form is picked up. In some cases, such as Holes 3 and 4 on both blocks, the effect is in the order of 8 μm which could make the difference between a pass and fail in a precision manufacturing environment.

However, there were two features for which the operations environment reported higher cylindricity than when performing the detailed measurement: Hole 2 on Block A and the Boss on Block B. There are at least two explanations for these seemingly counter-intuitive results. Firstly, at 1 μm and 0.6 μm respectively, the differences are small enough that they could be accounted for by an accumulation of measurement errors. Secondly, in the case of Hole 2, the number of points chosen in both the detailed and operations environment was a multiple of the number of lobes on the hole; it is therefore possible that similar high and low points were found using both strategies. This effect is well documented in the literature, and it is usually recommended that a prime number of points are taken [20].

7.2. Measurement consistency for stable measurands

Also observable from Table 3, and as visualized for Hole 5 in Figure 5, it can be seen that for the holes that had no deliberate errors, the highest observed mean cylindricity was 7.1 μm for the detailed measurement. The largest difference for this category of hole, as compared to the operations measurement, was 2.1 μm. Thus, the results from the detailed and operations systems correlate well where no significant form error is present.

7.3. Measurement consistency for unstable measurands

Having established that there appears to be a strong relationship between form and measurement strategy in this experiment, and that an operations strategy can be effective in a situation where there is little variation in the form induced by manufacturing, one might ask how effective a measurement strategy would be in the face of changing manufacturing output?

Figure 6 shows a situation where the operations strategy has been successful in clearly identifying a change in the form of a boss. In this instance, the large and sudden change from a feature that had no deliberate errors, to one in which a 25 μm error had been induced on three lobes, is clearly observable in the result.

However, it is less clear that the operations strategy would be effective in a situation where the change is less pronounced. For example, Figure 7 shows a scenario where the amplitude of a three lobe error has increased from 10 μm to 15 μm. The detailed measurement clearly spots the change;

however the result from the operations measurement is less definitive (8 μm difference as opposed to 13 μm for the detailed strategy).

7.4. Measurement consistency when operating at the margins

Theory supports the idea that one should be able to use measurement strategy as a lever for measurement uncertainty. By making use of uncertainty evaluating software, it should be possible to identify context-specific strategies to provide consistency in measurement across the supply chain.

The results from the case study are encouraging, though they also highlight potential dangers when manufacturing output is subject to subtle changes. Unfortunately, economic pressures will tend to force manufacturers to employ measurement systems that are only marginally capable [29]. Potential mitigations are listed below.

- One could repeat the detailed measurement at regular intervals to identify when there has been a change in form of sufficient magnitude to warrant a change in the operations strategy. This is recommended in NPL's guidance on the scientific approach [24], though assumes there is sufficient volume.
- In a medium volume environment, another approach could involve applying a systematic jitter to the strategy. There could be resistance to employing such an approach in highly-regulated environments where programs may be required to be validated before use. However, if it is found to be effective, the approach should be considered. Nonetheless, some errors may still be missed between those formulations of the strategy that capture the change in manufacturing output.
- Perhaps the most desirable option would be to simulate manufacturing variation, and test strategies against a range of manufacturing outcomes when making measurement uncertainty predictions, although this could result in overly conservative measurement strategies.

7.5. A systems perspective on measurement consistency

Thus far, the discussion has stayed within the confines of the measurement system. However, the key benefit of the proposed framework for controlling measurement consistency could be in opening discussions with manufacturing and design.

For example, if no operations strategy can be found that allows measurement uncertainty to be maintained within desired boundaries using available resources, a more appropriate solution may lie outside of measurement. It may be the case that manufacturing process could be modified so that the output is more stable; alternatively, there may be scope for a tolerance to be loosened; or a design change could be implemented to avoid the need for measuring the troublesome feature.

8. Limitations

The study was not intended to be an exhaustive experiment on measurement uncertainty prediction; rather, a contrived laboratory environment was used as a vehicle to highlight issues. Both the detailed and operations strategies were performed in well-controlled environments at a National Measurement Institute, and the CMM systems had only slight differences in capability. The results obtained exhibited high levels of repeatability. However, the scope of the study was restricted to a relatively small number of measurands, and a number of limitations should be noted.

- All measurements and simulations were carried out in discrete point mode. Scanning was not considered, even though this is an increasingly well-used mode of measurement in industry. Similarly optical probes and other types of coordinate measurement, such as laser trackers and measurement arms were not addressed. However, only discrete point measurement on CMMs is modelled in the simulation tool that was chosen.
- Cylindricity would normally be evaluated using many more points [30]. In fact, scanning or the use of another special-purpose measurement machine might have been more appropriate. However, recall that the intention of the study was to explore the effect of strategy on uncertainty, for which the study of cylindricity is well suited.
- The regularity of the form error on the artefacts may not necessarily be a fair representation of manufacturing output.
- The framework would indicate that a number of candidate strategies should be developed, to allow selection of the most appropriate one. In this study, only one candidate was developed.
- It would have been useful to study the results on more CMM systems.
- The integration of UES with other uncertainty evaluation techniques was not investigated.

Given these limitations, though encouraged by the initial results, further research is in progress to include the following:

- more measurands (features, characteristics, and less regular form error);
- more strategies (at differing levels of rigour);
- more CMM systems (at differing levels of accuracy);
- enhanced uncertainty evaluation through integration of other techniques (especially measurement history).

9. Concluding remarks

The term 'measurement consistency' was developed as a means to describe the goal of achieving comparable levels of measurement uncertainty when using different measurement systems. A framework was introduced by which measurement consistency can be controlled on CMMs in a PLM environment. The framework builds on the 'scientific approach' to developing measurement strategy; an approach

that was suggested by NPL over a decade ago [24], yet does not seem to have been widely adopted within industry.

The exploratory case study shows potential in the approach, and the benefits may extend beyond measurement consistency, to enable better informed discussions between measurement, manufacturing, and design.

Disclaimer

The identification of any commercial product or trade name does not imply endorsement or recommendation by the authors or their institutes.

Acknowledgements

This work was supported by the Systems Centre, the EPSRC funded Industrial Doctorate Centre in Systems (Grant EP/G037353/1), Rolls-Royce plc, and NPL (under the UK National Measurement System Engineering & Flow Metrology Programme). The authors are grateful to David Flack whose comments helped to improve and clarify the paper.

References

- [1] Stark J. (2005) Product lifecycle management: 21st century paradigm for product realisation. 2nd ed. London: Springer Verlag, p. 429-452.
- [2] Saunders P, Cai B, Maropoulos P, Orchard N. (2013) Towards a definition of PLM-integrated Dimensional Measurement. *Procedia CIRP*, 7, p. 670–675.
- [3] Phillips SD. (2012) Performance Evaluation. In Hocken RJ, Pereira PH (eds). *Coordinate Measuring Machines and Systems*, Boca Raton: CRC Press, p. 182–272.
- [4] Oxford University Press. (2013) consistency, n. OED Online. Retrieved December 17, 2013, from <http://www.oed.com>
- [5] Chan FMM, Davis EJ, King TG, Stout KJ. (1997) Some performance characteristics of a multi-axis touch trigger probe. *Measurement Science and Technology*, 8, p. 837–848.
- [6] Hocken RJ, Raja J, Babu U. (1993) Sampling issues in coordinate metrology. *Manufacturing Review*, 6.
- [7] Morse EP, Srinivasan V. (2013) Size tolerancing revisited: A basic notion and its evolution in standards. *Proceedings of the Institution of Mechanical Engineers, Part B: Journal of Engineering Manufacture*, 227:5, p. 662–671.
- [8] Weckenmann A, Estler T, Peggs G, McMurtry D. (2004) Probing Systems in Dimensional Metrology. *CIRP Annals - Manufacturing Technology*, 53:2, p. 657–684.
- [9] JCGM 200. (2008) International vocabulary of metrology — Basic and general concepts and associated terms (VIM).
- [10] ISO 15530-1. (2013) Geometrical product specifications (GPS) — Coordinate measuring machines (CMM): Technique for determining the uncertainty of measurement.
- [11] JCGM 100. (2008) Evaluation of measurement data — Guide to the expression of uncertainty in measurement.
- [12] Flack D. (2013) Measurement Good Practice Guide No. 130: Coordinate measuring machine task-specific measurement uncertainties.
- [13] ISO 15530-3. (2011) Geometrical product specifications (GPS) — Coordinate measuring machines (CMM): Technique for determining the uncertainty of measurement. Part 3: Use of calibrated workpieces or measurement standards.
- [14] ISO 15530-4. (2008) Geometrical Product Specifications (GPS) — Coordinate measuring machines (CMM): Technique for determining the uncertainty of measurement. Part 4: Evaluating task-specific measurement uncertainty using simulation.
- [15] Baldwin JM, Summerhays KD, Campbell DA, Henke RP. (2007) Application of Simulation Software to Coordinate Measurement Uncertainty Evaluation. *Measure*, 2:4, p. 40–52.
- [16] Bich W, Cox MG, Dybkaer R, Elster C, Estler WT, Hibbert B, et al. (2012) Revision of the “Guide to the Expression of Uncertainty in Measurement.” *Metrologia*, 49:6, p. 702–705.
- [17] Baldwin JM, Summerhays K, Campbell D. (2010) Evaluating the Economic Impact of CMM Measurement Uncertainty. In *Proceedings of Measurement Science*, Pasadena.
- [18] Weckenmann A, Knauer M, Kunzmann H. (1998) The influence of measurement strategy on the uncertainty of CMM-measurements. *CIRP Annals-Manufacturing*, 47:1, p. 451–454.
- [19] Moroni G, Petró S. (2014) Optimal inspection strategy planning for geometric tolerance verification. *Precision Engineering*, 38:1, p. 71–81.
- [20] BS 7172. (1989) Assessment of position, size and departure from nominal form of geometric features.
- [21] Hwang L, Lee H, Ha S. (2002) Hybrid neuro-fuzzy approach to the generation of measuring points for knowledge-based inspection planning. *International Journal of Production Research*, 40:11, p. 2507–2520.
- [22] Moroni G, Petró S. (2011) Coordinate Measuring Machine Measurement Planning. In Colosimo BM, Senin N (eds). *Geometric Tolerances*, London: Springer, p. 111–158.
- [23] Ascione R, Moroni G, Petró S, Romano D. (2012) Adaptive inspection in coordinate metrology based on kriging models. *Precision Engineering*, 37:1, p. 44–60.
- [24] Flack D. (2001) Measurement Good Practice Guide No. 41: CMM Measurement Strategies.
- [25] Lobato H. (2011) An investigation into CMM task specific measurement uncertainty and automated conformance assessment of airfoil leading edge profiles. University of Birmingham, Chapter 3, p. 6-36.
- [26] Leach R. (2010) Coordinate metrology. In *Fundamental Principles of Engineering Nanometrology*, Oxford: Elsevier, p. 263–288.
- [27] Carl Zeiss (2013) Calypso. Retrieved January 17, 2014, from http://metrology.zeiss.com/industrial-metrology/en_gb/products/software/calypso.html
- [28] Trapet E, Franke M, Härtig F, Schwenke H, Wäldele F, Cox M, et al. (1999) Traceability of Coordinate Measurements According to the Method of the Virtual Measuring Machine, Final Project Report MATI-CT94-0076, PTB-report F-35, Part 1 and 2. Braunschweig.
- [29] Orchard N. (2011) CMM future demands – measurement at the edge. Retrieved January 17, 2014, from <http://www.nimtech.ptb.de/nimtech>
- [30] Henzold G. (2006) Geometrical dimensioning and tolerancing for design, manufacturing and inspection: a handbook for geometrical product specifications using ISO and ASME standards. 2nd ed. Oxford: Butterworth-Heinemann, p. 242-249.