

Fabry-Perot micro-structured polymer optical fibre sensors for opto-acoustic endoscopy

Christian Broadway¹, Daniel Gallego¹, Getinet Woyessa³, Andreas Pospori², Guillermo Carpintero¹, Ole Bang³, Kate Sugden², Horacio Lamela¹

¹Opto-Electronics and Laser Technology Group (GOTL), Universidad Carlos III de Madrid, ²Aston Institute of Photonic Technologies, Aston University, ³DTU Fotonik, Denmark Technical University

ABSTRACT

Opto-Acoustic Endoscopy (OAE) requires sensors with a high sensitivity and small physical dimensions in order to facilitate integration into an endoscope of less than 1mm in diameter. We present fibre Bragg grating (FBG) and Fabry-Perot intrinsic fibre sensors for ultrasound detection. We present a structure profile characterisation setup to analyse tune the fibre sensors in preparation for ultrasonic detection. We evaluate the suitability of the different structures and grating parameters for ultrasonic sensing. By analysing the prepared gratings, we enable the optimisation of the profile and a simplification of the detection regime for an optimal interferometric OAE configuration.

Keywords: Polymer Optical Fibre Sensors, Ultrasonic Sensors, Fabry-Perot, Fibre Bragg Gratings, Opto-Acoustic Endoscopy

1. INTRODUCTION

Jenson et al, while demonstrating *ex vivo* vascular opto-acoustic imaging, identified two factors that prevented an immediate transition from *ex vivo* to *in vivo* analysis; probe diameter and laser repetition rate [1]. The required probe diameter was stated to be less than 1mm for clinical imaging, which to date has not been achieved according to the most recent publications. In 2012, Yang et al demonstrated *in vivo* imaging of internal organs using a 2.5mm (diameter) dual-mode (opto-acoustic and ultrasonic) endoscope using a toroidal piezo-electric transducer as a detector [2]. In 2014, a 1.1mm probe was developed by Bai et al [3]. Their submission discusses some of the difficulties associated with size vs. sensitivity that are an inherent issue when considering piezo-electric transducers for miniature applications.

Conventional piezo-electric transducers are highly sensitive but have a number of failings in specific circumstances. Our group has previously listed their sensitivity being proportional to size, having a limited bandwidth and being susceptible to electromagnetic interference [4]. These three issues are fundamentally linked to the nature of piezo electric transducers and need to be overcome by substitution or mitigated by trade-offs. As both a wide bandwidth and a small detector size are required for this application, it is propitious to seek materials that are more suitable to the task at hand and that can also deliver a similar level of sensitivity.

Our group is developing smaller endoscopic detectors that will contribute to reducing probe diameters towards the size mentioned by Jenson et al. The substitution of polymer optical fibre (POF) can deliver the required characteristics due to its mechanical properties and implementation potential, specifically the compactness, sensitivity and bandwidth. Intrinsic fibre structures such as fibre bragg gratings (FBG) and Fabry-Perot cavities offer significant potential. However, POF is relatively new and has a number of disadvantages, most of which are related to the newness of the technology and limited commercialisation.

Silica fibre and POF are electromagnetically insensitive and can provide a wide and customizable bandwidth for sensing, especially when using intrinsic fibre structures. It is important to note, however, the important advantages that POF has over silica. While silica is commercially available and indeed mature, it presents a hazard to those who wish to cleave and splice it, even in the laboratory. The mechanical properties of POF not only reduce safety concerns but also present the potential for greater sensitivity. It is important to note that several polymers exist under the banner of polymer optical fibre, the most common of which being Poly-Methyl-Methacrylate (PMMA). Bilro et al give the Young's Modulus of PMMA as 3.2GPa, compared to 72GPa for Silica [5]. Furthermore, Peters lists the elastic limit of PMMA as 10% compared to 3% for silica [6]. These qualities not only show higher potential for acoustic sensitivity but also highlight the reduced risk of fracture and bending for POF compared to silica. While these figures may vary for different

*cbroadwa@ing.uc3m.es; phone +34 624 8758; portal.uc3m.es/portal/page/portal/grupos_investigacion/optoelectronics

variations of the polymer PMMA and indeed for other polymers, it shows the scope and potential that POF offers for Endoscopic implementation.

We have previously demonstrated that the acoustic sensitivity of an interferometric single mode polymer optical fibre sensor (SMPOF) is one order of magnitude higher than a silica counterpart [7]. However, these SMPOF are not easily commercially available and its performance in terms of loss is very poor, making them impractical for implementation. In contrast, micro-structured polymer optical fibre (mPOF), exhibits the same acoustic sensitivity, presents moderate low loss at visible wavelength regime and can be made endlessly single-mode. It has been shown that mPOF is more than 10 times more sensitive than single-mode POF for ultrasonic signals at 1 and 10 MHz [8].

Having selected the fibre type and the fibre structure, our group recommended that a promising avenue is to write gratings in mPOF and to use the intrinsic structure for sensing [8]. Intrinsic structures have the benefit of confining sensing to the area of the structure, eliminating the detection of effects at other areas of the fibre. Due to the birefringent nature of POF and the physical nature of mPOF, grating inscription is less uniform, generating a great need for analysis and optimization. Furthermore, fibre structures that are analysed and optimized before use allow the simplification of the interrogation regime and system calibration, by aligning the fibre structure to the optimal wavelength for the interrogation laser as opposed to aligning the laser to the structure. By so doing, lasers with limited or no tuning capability may be used, reducing the cost of implementation.

In this contribution, we present an analysis of the potential of intrinsic fibre structures for endoscopic ultrasonic sensors, by presenting a profile characterization setup, analysing structure profiles and evaluating the suitability of the profile vis-à-vis ultrasonic sensing. We explore the possibilities of using Fabry-Perot cavities and FBGs for ultrasonic sensing and assess the difficulties and potential of using each structure mode. We analyse the tuning capabilities for the Bragg wavelength by applying strain and evaluating the effect on the grating profile and the linearity of the applied wavelength shift.

2. METHODOLOGY

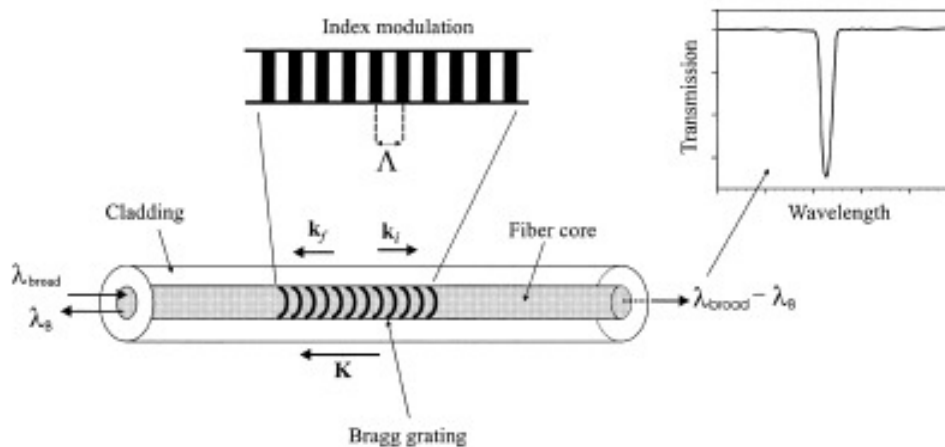

Figure 1. Overview of FBG Sensing and the effect on the transmitted spectrum [9]

An inscribed FBG is a periodic modulation of the refractive index of the fibre. As Figure 1 shows, this modulation produces a negative peak in the transmission spectrum around a central wavelength, known as the Bragg wavelength. FBG sensing is typically done in a reflection configuration, where the grating produces a positive peak around the Bragg wavelength, whose shape and power depend upon the characteristics of the grating inscription parameters.

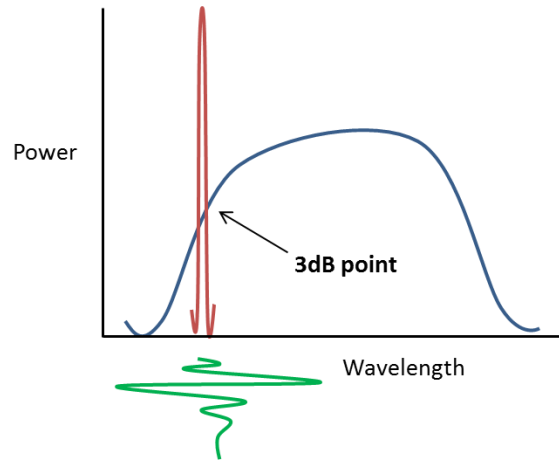

Figure 2. Sketch of a reflected spectrum profile of an FBG (blue) that is then used with a tuneable laser (red) and an incident ultrasonic wave (green) that induces a shift in the FBG profile

An ultrasonic wave incident on an FBG will cause a wavelength shift in the grating profile. By tuning a laser to the wavelength where the reflected power is 3dB below the peak reflectance, the induced wavelength shift will be displayed as an output power variation. Figure 2 shows the grating profile (blue) that has been examined and the 3dB point located. A more focused laser is then tuned to this wavelength (red) and the incident ultrasonic wave (green) creates a wavelength variation that is observed as a change in output power.

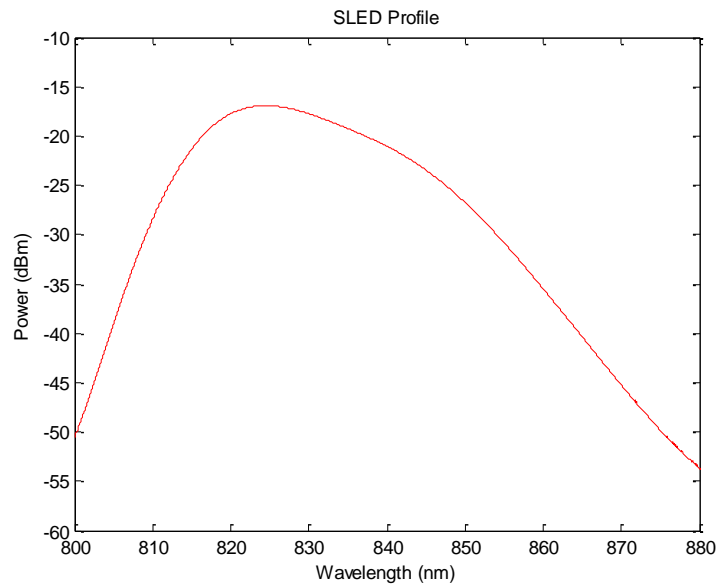

Figure 3. Reflected SLED profile

A super-luminescent diode (SLED, Exalos EXS210005-02) is used as the laser source for the profile characterization setup, with an effective range of 810 – 870nm (the profile of the SLED can be observed in figure 3). The SLED is connected directly to a fibre isolator that prevents harmful back-reflection from damaging the SLED and from altering either the output amplitude and/or the spectral profile. The reflected spectrum is observed using an optical spectrum analyser.

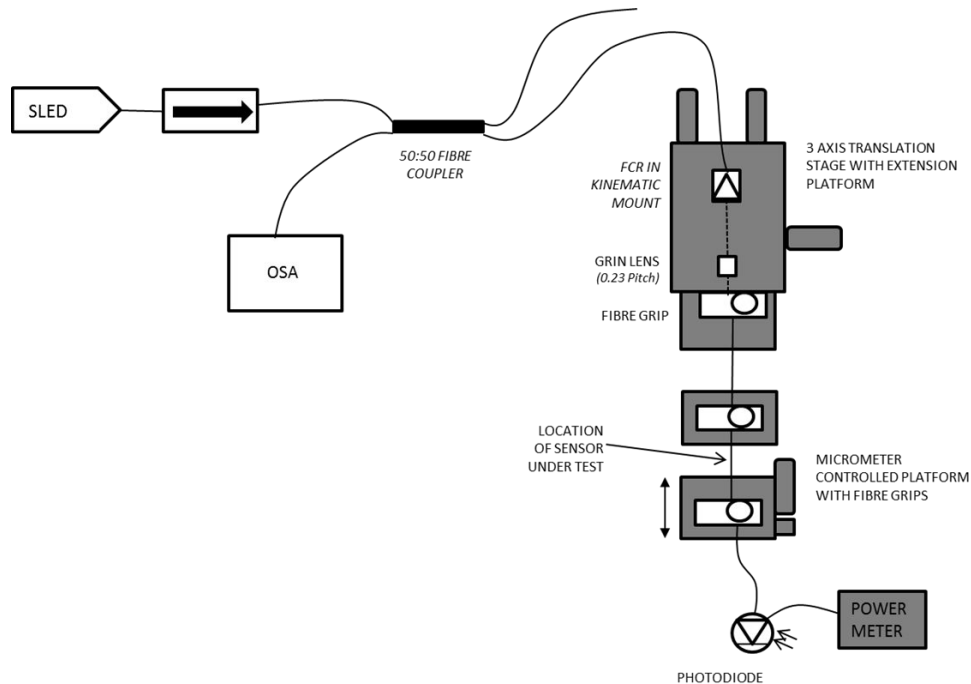

Figure 4. Schematic of the structure profile characterization setup

Figure 4 shows a schematic of the profile characterization setup. From the optical isolator, a 50:50 fibre coupler permits the observation of the reflected spectrum from the optical spectrum analyser. The coupler also leads to an in-fibre collimator that allows for free space coupling into the polymer fibre under examination. From the collimator, a GRIN lens aids with coupling into the fibre, which is held in a grip. Coupling is made possible with a collimator and grip on a micrometre controlled 3 axis translation stage, with the addition of a 2 axis mount for the collimator itself. To understand and define the possibilities of tuning the Bragg wavelength by applying strain, a section consisting of two platform mounted grips allows micrometre controlled x axis displacement to be applied to a specific length of fibre. The fibre end is fed into a photodiode to assist with free space alignment.

We have analysed the potential of intrinsic fibre structures for endoscopic ultrasonic sensors and established methodology for the analysis of the structure profile. We have explored the possibilities of using Fabry-Perot cavities and FBGs for ultrasonic sensing and assess the difficulties and potential of using each structure mode. We have furthermore analysed the tuning capabilities for the Bragg wavelength.

For this analysis we have used PMMA 3 ring mPOF fibres with diameters of $125\mu\text{m}$ and lengths of 20cm. Each fibre has either an FBG or a Fabry-Perot cavity inscribed. Other parameters vary in order to compare different fabrication methods and will be detailed during the discussion of our obtained results.

3. DISCUSSION OF RESULTS

We have measured the reflected spectrum from the fibres under test to validate the characterization procedure, assess the suitability of the different structures for ultrasonic detection and analyse the tuning capabilities of the structures.

Fibre Bragg Gratings

Many variables can affect POF, especially considering the added complications of mPOF; contamination of holes and greater inscription difficulty being two key points. While FBGs can be inscribed repeatedly with consistent results in

silica, the birefringence of polymer fibre and the difficulties associated with mPOF significantly affect the repeatability. Figure 5 shows the profile of an FBG (referred to as 'Fibre 1') that we have analysed.

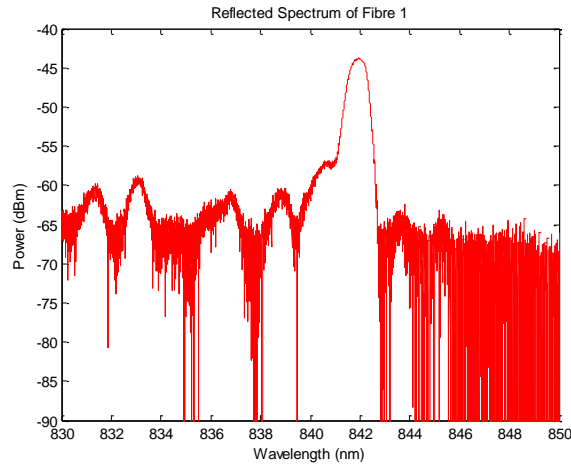

Figure 5. Reflected spectrum of 'Fibre 1'

We can observe an inhomogeneous spectral response with a main peak and 4 side lobes, however a clear peak is observed that could be used for ultrasonic measurements, due to the uniform slope on the right hand side and the partially uniform section at the top of the left hand side. There is a strong peak, however the FBG has a 3dB bandwidth of 0.6nm, which is less than would be preferred.

There are two purposes to presenting this evaluation, first being that tuning measurement are made using this FBG in order to provide an 'ideal' scenario for tuning, as Fabry-Perot cavities suffer from a tuning variation between the two FBGs. Secondly, as Fabry-Perot cavities are the aim of this submission, these measurements are used as a benchmark in order to evaluate suitability compared to simpler structures.

Fabry-Perot Cavities

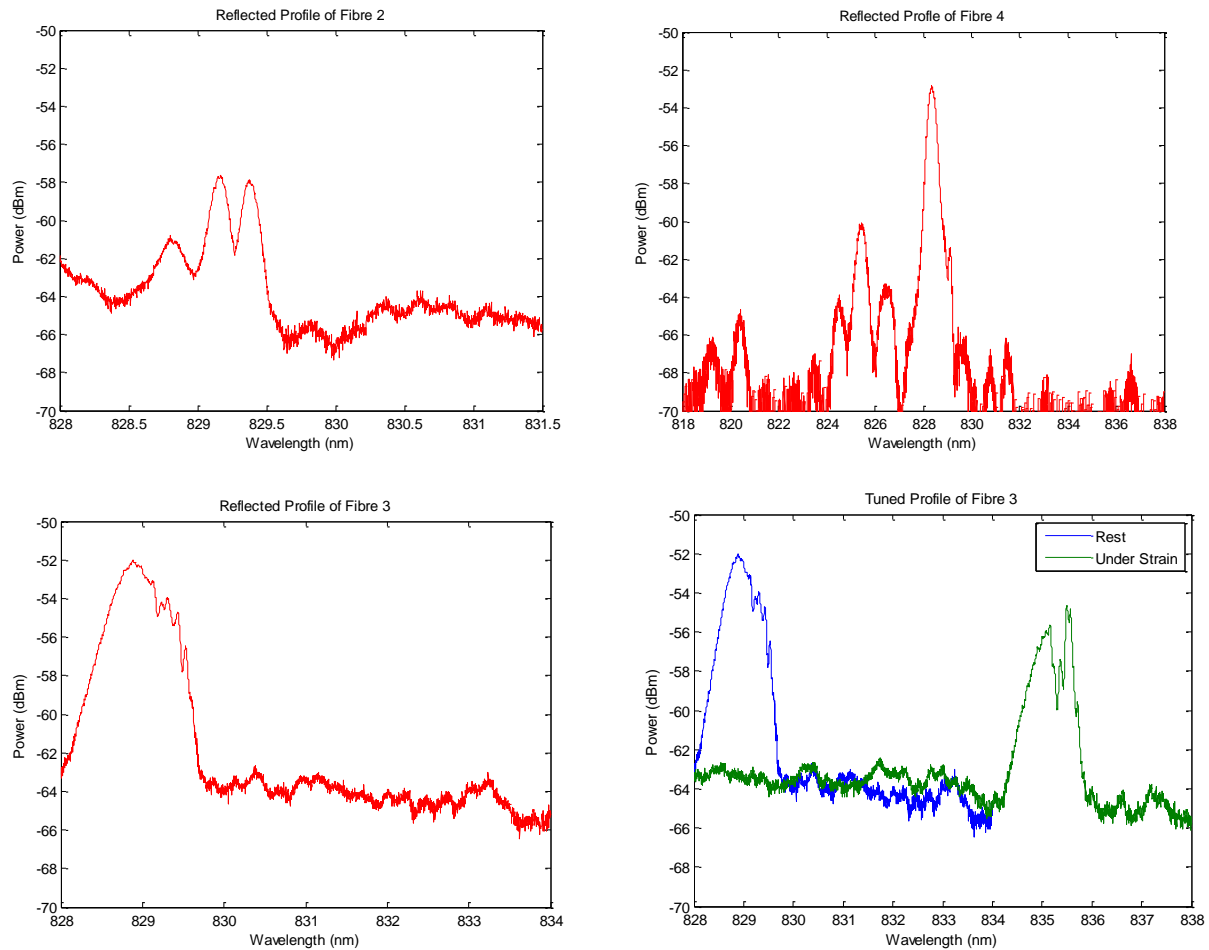

Figure 6. Characterised Fabry-Perot cavity profiles in PMMA mPOF. Fabry-Perot 'fibre 2' profile (top left), Fabry-Perot 'Fibre 3' Profile (bottom left), Fabry-Perot 'fibre 4' profile (top right), Tuning the profile of 'Fibre 3' (bottom right)

As can be observed from figure 6, fabricating Fabry-Perot cavities in PMMA mPOF does not produce profiles consistent with theoretical models due to previously mentioned factors. The problems are quickly apparent when comparing the fibres, where 3 different Fabry-Perot cavities are inscribed in 3 fibres from the same batch using the same setup, phase mask and similar grating lengths (9mm and 10mm). We observe the paired FBGs in a very detuned state in the top left, compared to a well attuned state in the bottom left graph. This is due to the applied strain and ambient temperature at the time of inscription as compared to the applied strain and ambient temperature during profile characterisation, demonstrated by the graph on the bottom right. Strain is applied to a well attuned Fabry-Perot cavity, resulting in a visible separation of the constructively interfering peaks of the paired Bragg gratings. This resultant profile can be profitably compared to both of the graphs at the top of figure 6.

This leads to the conclusion that the paired Bragg gratings can be re-attuned using temperature adjustment and/or applied strain in a manner that can be repeatable by analysing the shift in the structure profile caused by both effects. Due to the negative thermo-optic co-efficient and the positive strain-optic co-efficient, by comparing the Bragg wavelength of the profile to the target wavelength, we can determine the relevant parameter to modify. By providing better grating tuning we may observe a greater return power and a smoother gradient. While tuning is a powerful tool, it is important to note that the method of applying strain and temperature is more important than anything else. Figure 6 demonstrates that by

applying strain to the whole cavity using the given setup, there is not a uniform distribution of strain leading to a detuning of the respective Bragg wavelengths.

One further conclusion can be reached based on a comparison of the graphs. The difference in inscription between the profile on the bottom left and the profiles at the top is a difference in the employment of the phase mask. By inscribing a shorter cavity without moving the phase mask for the inscription of the 2nd FBG, the need for repositioning the fibre is removed, resulting in more coherent profiles. While this limits the cavity size to the dimensions of the phase mask window, it provides one means to improve the repeatability of structure inscription. Furthermore, with ultrasonic sensing requiring smaller sensors this limitation is not significant for this application, especially when considering that for a theoretical endoscope of less than 1mm in diameter, cavity lengths over the current limit of 9mm will be difficult to employ.

Tuning Analysis

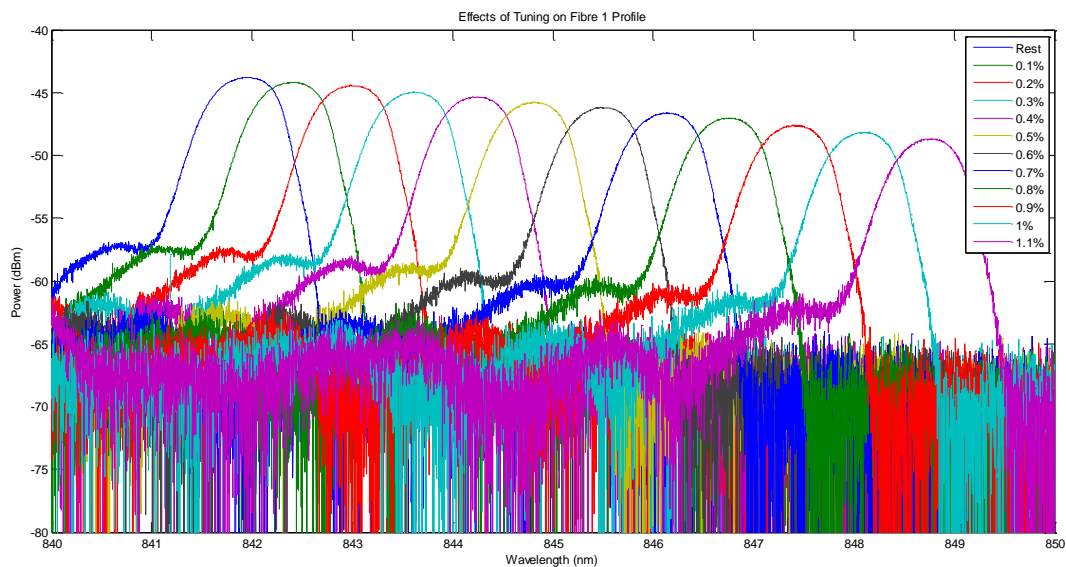

Figure 7. Tuning an FBG profile by the application of strain

Further to the expectations outlined regarding straining vis-à-vis Fabry-Perot cavity alignment, we have analysed the tuning capabilities of strain on FBGs as shown by figure 7. By applying micrometre controlled displacement to the grating profile shown in figure 5, we observe a positive wavelength shift. The small decrease in amplitude as strain is applied is due to the SLED profile power decreasing, as can be observed in figure 3. Following the tuning the strain was released and the results compacted and analysed. These results are present in figure 8.

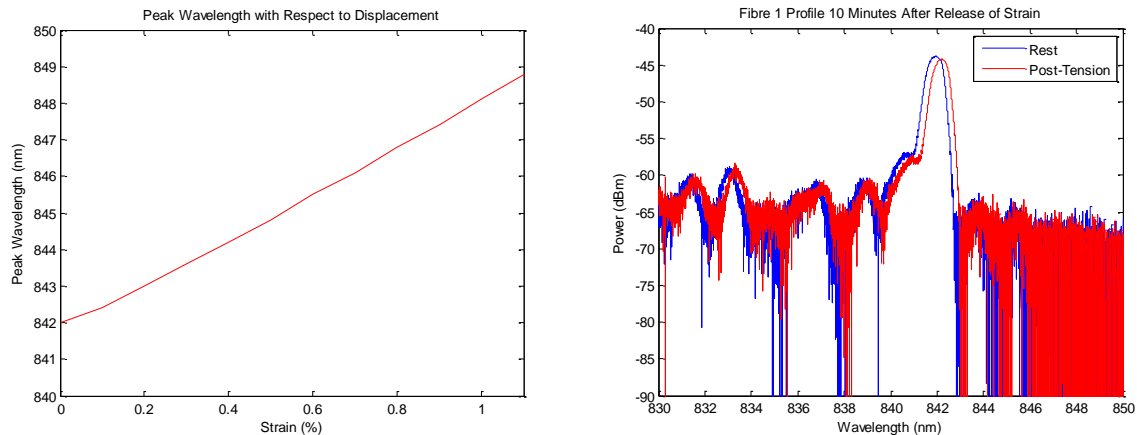

Figure 8. Analysis of fibre tuning and the effects on the resultant spectrum of 'Fibre 1' after removal of strain

By applying a linear fit to the first graph, we can observe that the tuning potential is $0.77\text{nm/m}\epsilon$. Furthermore, the linear fit is an almost exact match to the results obtained, allowing us to assert that the displacement is sufficiently linear to be used for accurate approximations of Bragg Wavelength for a given strain.

We have also analysed the hysteresis relative to the Bragg wavelength 10 minutes after a release of the strain. We can observe a permanent shift in the grating profile, positively indicating that by applying strain, a permanent Bragg wavelength change could be effected. Considering the lack of space within an endoscopic probe this shows promise for the use of intrinsic structures, even given differences in inscription. To use this effect accurately however, further research would be required into permanent shift compared to strain applied and the temporary shift visible. Other testing would also be useful as the grating required 10 minutes in this instance to stabilise after the full release of strain. The stabilisation time may change depending on the strain applied and as the process is slow (traversing fractions of a nanometre over several minutes); it is difficult to visually determine the end of the process except by time passing with no visible change.

4. CONCLUSIONS AND FUTURE WORK

We have presented an analysis of intrinsic fibre structures for endoscopic ultrasonic sensors and presented the utilised profile characterization setup. We have explored the possibilities of using Fabry-Perot cavities and FBGs for ultrasonic sensing. We have also analysed the tuning capabilities for the Bragg wavelength and evaluated the effect on the grating profile and the linearity of the applied wavelength shift.

We conclude that Fabry-Perot cavities are a promising structure to work with; however they require repeatable methods of tuning to overcome the difficulties faced with fabrication. We have shown that an FBG may be tuned in a linear fashion and that hysteresis might be positively used to tuning a structure to the wavelength of a given laser. We have also demonstrated that simple techniques such as not moving a phase mask for the inscription of the 2nd FBG, improve the quality of the resultant Fabry-Perot cavity. We have demonstrated that there is a linear tuning capability when using strain at a rate of $0.77\text{nm/m}\epsilon$.

To further the development of this technology, two avenues of research need to be investigated further, sensor optimization and detector development. Sensor optimization work includes developing a method to align gratings within a Fabry-Perot cavity that is repeatable and predictable, analysis of further polymer types and improving sensor fabrication. Detector development covers the examination of different sensor topologies and quantities, imaging with intrinsic mPOF structures and finally an endoscope probe design.

ACKNOWLEDGEMENTS

The research leading to these results has received funding from the People Programme (Marie Curie Actions) of the European Union's Seventh Framework Programme FP7/2007-2013/ under REA grant agreement n° 608382.

We acknowledge and thank David Saez Rodriguez, who fabricated the PMMA fibres that were inscribed and characterised in this paper.

REFERENCES

- [1] K. Jansen, A. F. W. van der Steen, H. M. M. van Beusekom et al., "Intravascular photoacoustic imaging of human coronary atherosclerosis," *Optics Letters*, 36(5), 597-599 (2011).
- [2] J.-M. Yang, C. Favazza, R. Chen et al., "Simultaneous functional photoacoustic and ultrasonic endoscopy of internal organs in vivo," *Nature Medicine*, 18(8), 1297 (2012).
- [3] X. Bai, X. Gong, W. Hau et al, "Intravascular Optical-Resolution Photoacoustic Tomography with a 1.1 mm Diameter Catheter" 20 March 2014 (8th June 2015).
<http://www.ncbi.nlm.nih.gov/pmc/articles/PMC3961364/pdf/pone.0092463.pdf>
- [4] H. Lamela, D. Gallego and A. Oraevsky, "Optoacoustic Imaging using fiber-optic interferometric sensors", *Optics Letters* 34(23), 3695-3697 (2009).
- [5] L. Bilro, N. Alberto, J. L. Pinto and R. Nogueira, "Optical Sensors Based on Plastic Fibers", *Sensors* 2012 ISSN 1424-8220 www.mdpi.com/journal/sensors
- [6] K. Peters, "Polymer Optical Fibre Sensors – A Review", *Smart Materials and Structures* 2010
- [7] D. Gallego, and H. Lamela, "High-sensitivity ultrasound interferometric single-mode polymer optical fiber sensors for biomedical applications," *Optics Letters*, 34(12), 1807-1809 (2009).
- [8] D. Gallego, D. Saez Rodriguez, D. Webb et al, "Interferometric microstructured polymer optical fiber ultrasound sensor for optoacoustic endoscopic imaging in biomedical applications", *Proc. of SPIE Vol. 9157* (2014)
- [9] Othonos A. and Kailli K., ["Handbook of Advanced Electronic and Photonic Materials and Devices], Volume 9: Nonlinear Optical Materials, Chapter 9", Academic Press (2001)