

A STUDY OF THE REACTIONS OF C-NITROSO COMPOUNDS WITH  
BASE BY MEANS OF ELECTRON SPIN RESONANCE SPECTROSCOPY.

BY

ROGER JEREMY MARTIN GILES

SUBMITTED FOR THE DEGREE OF DOCTOR OF PHILOSOPHY IN  
THE FACULTY OF SCIENCE, UNIVERSITY OF LONDON.

BEDFORD COLLEGE, 1979.

ProQuest Number: 10098362

All rights reserved

INFORMATION TO ALL USERS

The quality of this reproduction is dependent upon the quality of the copy submitted.

In the unlikely event that the author did not send a complete manuscript and there are missing pages, these will be noted. Also, if material had to be removed, a note will indicate the deletion.

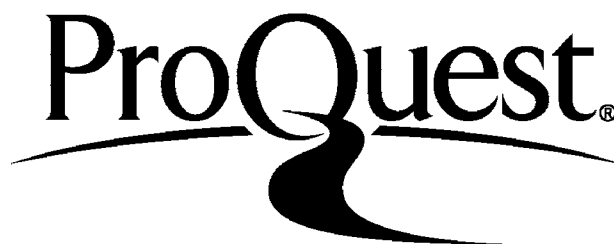

ProQuest 10098362

Published by ProQuest LLC(2016). Copyright of the Dissertation is held by the Author.

All rights reserved.

This work is protected against unauthorized copying under Title 17, United States Code.  
Microform Edition © ProQuest LLC.

ProQuest LLC  
789 East Eisenhower Parkway  
P.O. Box 1346  
Ann Arbor, MI 48106-1346

### ACKNOWLEDGEMENT

The author wishes to express his gratitude for the guidance and encouragement given by Dr. W.T. Dixon and Professor G.H. Williams.

He also wishes to thank Dr. R. Bolton for many helpful discussions and Dr. B.P. Roberts of University College for the use of computer simulation facilities.

Finally, he wishes to thank Miss C.E. Panton for typing the manuscript and the Science Research Council for the award of a Research Studentship.



C O N T E N T S

	PAGE
ABSTRACT .. .. .	1
<u>CHAPTER 1</u> : INTRODUCTION .. .. .	7
<u>1.1</u> Outline of the Theory of Electron Spin Resonance (e.s.r.) Spectroscopy .. .. .	7
<u>1.2</u> <u>C</u> -Nitroso Compounds .. .. .	21
<u>1.3</u> Spin Trapping .. .. .	25
<u>1.4</u> The Reduction of <u>C</u> -Nitroso Compounds .. .. .	27
<u>CHAPTER 2</u> : PARAMAGNETIC PRODUCTS OBSERVED BY ESR SPECTROSCOPY FROM THE REDUCTION OF SUBSTITUTED NITROSOARENES ..	42
<u>2.1 A</u> Nitrosobenzene .. .. .	43
<u>2.1 B</u> 2,4,6-Tribromonitrosobenzene (VI) .. .. .	44
<u>2.1 C</u> 2,6-Dibromonitrosobenzene (VII) .. .. .	46
<u>2.1 D</u> 2,4,6-Trichloronitrosobenzene (VIII) .. .. .	48
<u>2.1 E</u> 2,6-Dichloronitrosobenzene (IX) .. .. .	49
<u>2.1 F</u> Mechanism of loss of Halogen from the Nitrosoarenes ..	59
<u>2.1 G</u> 2,4,6-Tri-t-butylnitrosobenzene (X) .. .. .	60
<u>2.1 H</u> 2,6-Difluoronitrosobenzene (XI) .. .. .	61
<u>2.1 J</u> 2,4,6-Trifluoronitrosobenzene (XII) .. .. .	62
<u>2.1 K</u> 2,3,5,6-Tetrafluoronitrosobenzene (XIII) .. .. .	62
<u>2.1 L</u> Pentafluoronitrosobenzene (XIV) .. .. .	63
<u>2.2</u> The Dimeric Radical-Anions derived from Chlorine or Bromine Substituted Nitrosobenzene .. .. .	73
<u>2.3</u> The Dimeric Radical-Anions derived from Fluorine Substituted Nitrosobenzene .. .. .	78
<u>2.4</u> Linewidth Variations in the Nitrogen- and Fluorine- Containing Radicals Detected .. .. .	98

	PAGE
<u>CHAPTER 3</u> : ESR STUDIES OF THE REACTION OF <u>C</u> -NITROSO COMPOUNDS WITH ALKYL HALIDES IN THE PRESENCE OF A BASE	
[REACTION (xv)] .. .. .	107
<u>3.1 A</u> Nitrosobenzene .. .. .	108
<u>3.1 B</u> 2,4,6-Tribromonitrosobenzene (VI) .. .. .	110
<u>3.1 C</u> 2,6-Dibromonitrosobenzene (VII) .. .. .	111
<u>3.1 D</u> 2,4,6-Trichloronitrosobenzene (VIII) .. .. .	112
<u>3.1 E</u> 2,6-Dichloronitrosobenzene (IX) .. .. .	114
<u>3.2</u> The Mechanism of Nitroxide Formation in the Reaction of <u>C</u> -Nitroso Compounds with a Base and Alkyl Halide [Reaction (xv)] .. .. .	126
<u>3.3</u> Spin Trapping .. .. .	128
<u>3.4</u> The Effect of a Nitroarene .. .. .	133
<u>3.5</u> The Formation of a Reactive Radical in the Reaction of a Base and a <u>C</u> -Nitroso Compound .. .. .	135
<u>3.6</u> The Use of Electrolysis for <u>C</u> -Nitroso-Radical-Anion Production .. .. .	140
<u>3.7</u> The Reaction between a Nitroarene Radical-Anion and an Alkyl Iodide .. .. .	146
<u>3.8</u> An ESR Investigation of the Reaction of 2-Methyl-2- Nitrosopropane with an Alkyl Iodide and Base .. .. .	150
<u>3.9</u> The Krönke Reaction .. .. .	154
<u>3.10</u> A Steric Effect in Reaction (xv) .. .. .	160
<u>3.11</u> The Second Type of Persistent Radical detected from Reaction (xv) .. .. .	167

<u>3.12</u>	An ESR Investigation of the Reaction of Nitrosoarenes with Polyhalogenomethanes .. .. .	172
<u>3.13</u>	An ESR Investigation of the Reactions of Fluorine Substituted Nitrosoarenes with Alkyl Halides in the presence of a Base .. .. .	184
<u>CHAPTER 4</u>	: EXPERIMENTAL .. .. .	198

T A B L E S

	PAGE
<u>1.1</u> <u>g</u> -Values of some Organic Radicals .. .. .	11
<u>1.2</u> Typical <u>g</u> -Values for Nitroxides $R^1R^2NO\cdot$ .. .. .	11
<u>2.1</u> ESR Spectral Parameters of the Nitrosoarene Radical-Anions	66
<u>2.2</u> ESR Spectral Parameters of the Nitroarene Radical-Anions	67
<u>2.3</u> ESR Spectral Parameters of the Nitrosylsulphinate Radical-Anions $[ArN(SO_2^-)O\cdot]$ .. .. .	68
<u>2.4</u> ESR Spectral Parameters of the Dimeric Radical-Anions from Chlorine- or Bromine- substituted nitrosobenzene .. ..	76
<u>2.5</u> ESR Spectral Parameters of the Dimeric Radical-Anions detected from Fluorine Substituted Nitrosobenzene .. ..	83
<u>2.6</u> ESR Spectral Parameters of Radical-Anions relevant to Sections 2.2 and 2.3 .. .. .	84
<u>2.7</u> Experimental and Calculated Relative Linewidths ( $W_i$ ) for $XC_6F_4NO\cdot$ .. .. .	103
<u>3.1</u> ESR Spectral Parameters of the Nitroxides $ArN(R)O\cdot$ detected from Reaction (xv) .. .. .	115
<u>3.2</u> ESR Spectral Parameters of the Nitroxides $Bu^tN(R)O\cdot$ observed from the Reaction $Bu^tNO + RI + base$ (or cathode) in DMSO	152
<u>3.3</u> ESR Spectral Parameters of the nitroxides 2,4,6- $Bu^tC_6H_2N(R)O\cdot$ detected from the Reaction, (X) + RI + Base (or Cathode) in DMSO .. .. .	164
<u>3.4</u> ESR Spectral Parameters of the <u>N</u> -alkoxyanilino Radicals 2,4,6- $Bu^tC_6H_2NOR$ detected from the Reaction, (X) + RI + Base (or Cathode) in DMSO .. .. .	165



	PAGE
<u>3.5</u> ESR Spectral Parameters of the Second Class of Persistent Radical Observed from Reaction (xv) .. ..	171
<u>3.6</u> ESR Spectral Parameters of the Nitroxides 2,6- $F_2C_6H_3N(R)O\cdot$ detected from (XI) in Reaction (xv) .. ..	185
<u>3.7</u> ESR Spectral Parameters of Secondary Nitroxides Observed from (XI) in Reaction (xv) .. .. .	186
<u>3.8</u> Splitting Constants of the Nitroxides (Type E) detected from (XIV) in Reaction (xv) in DMSO or DMF solution ..	189
<u>4.1</u> Melting Points of and Recrystallising Solvents used for the Chlorine or Bromine Substituted Nitrosobenzenes ..	206

CHAPTER 1.

INTRODUCTION

Section 1.1

Outline of the Theory of Electron Spin Resonance (e.s.r.) Spectroscopy.

It is necessary to give a brief introduction to some of the principles of the e.s.r. technique relevant to the investigation undertaken. Full descriptions of the theories and applications of e.s.r. spectroscopy are given in numerous books and reviews.<sup>1</sup>

If the electron is considered as a spinning charged body it will have an associated magnetic moment ( $\mu$ ) given by:

$$\mu = -g\beta S \quad (1)$$

where  $S$  is the spin vector of the electron,  $g$  is known as the "g-factor" or spectroscopic splitting factor (for a free electron  $g = 2.00232$ ),<sup>2</sup> and  $\beta$  is the Bohr magneton, a factor for converting angular momentum to magnetic moment.

$$\beta = \frac{eh}{4\pi mc} \quad ( = 9.2741 \times 10^{-21} \text{ erg G}^{-1} )$$

$e$  and  $m$  are the electronic charge and rest mass respectively,  $c$  is the velocity of light and  $h$  is Plank's constant.

The quantum mechanical solution for the angular momentum properties of the electron allows only specific orientations with respect to a reference direction. Thus the associated magnetic moment is orientation-quantised. For a reference direction ( $Z$ ) (for example, the direction of a static external magnetic field) the component of magnetic moment in

the Z-direction is given by

$$\mu_z = -g\beta M_s \quad (ii)$$

$M_s$  is the magnetic spin quantum number =  $\pm \frac{1}{2}$ . The energy of interaction of the magnetic moment  $\mu_z$  with a magnetic field  $H_z$  is  $E = -\mu_z H_z$

$$\therefore E = g\beta M_s H_z = \pm \frac{1}{2} g\beta H_z \quad (iii)$$

Thus there are two energy states differing in energy by  $\Delta E = g\beta H_z$  (iv)

If an electromagnetic field of frequency  $\nu$ , where  $h\nu = g\beta H_z$ , is allowed to interact with the electron the electron's spin may be reversed and energy absorbed from the electromagnetic field. This forms the basis of the resonance experiment. In fact, the magnetic dipole of the electron interacts with the oscillating magnetic field of the electromagnetic radiation and transitions occur only if the radiation is polarized such that the oscillating magnetic field has a component perpendicular to the static magnetic field. This condition is necessary to cause the change in the orientation of the electron magnetic moment. A parallel oscillating magnetic field would merely cause the energies of the spin states to oscillate.

Equation (iv) shows that the energy difference between the two spin states is directly proportional to the applied field  $H_z$ . The population of the two levels is given by the Boltzmann expression.

$$\frac{n_1}{n_2} = \exp(-g\beta H/kT). \quad (v)$$

$n_1$  = number of particles in the upper state

$n_2$  = number of particles in the lower state

$k$  = Boltzmann's constant

$T$  = absolute temperature.

Thus the higher the value of the applied field the greater will be the population difference ( $n_2 - n_1$ ) and hence the greater the net absorption of energy and consequent sensitivity of the spectrometer.

Practical considerations dictate use of a magnetic field of ca. 3400 G for most spectrometers, the corresponding radiation frequency being ca. 9.5 GHz (microwave, X-band region). The frequency is kept constant and the field value is varied to generate the spectrum.

### g-Values

The g-values of most organic free radicals are within 1% of the free electron value. The presence of incompletely quenched orbital angular momentum causes the deviation from the free electron value and introduces anisotropy. For fluid solutions, however, an isotropic value is observed due to rapid tumbling of the radical. The anisotropy of g is accommodated by writing it as a second-rank tensor. If it is possible to choose an orientation of the radical, as in the solid state, it may be possible to diagonalise the g-tensor, having the non-zero elements (called the principal components) on the diagonal. An approximate theoretical treatment<sup>3</sup> gave the relationship:

$$\Delta \underline{g} = \sum_i (\rho_i \eta_i / \Delta E_i)$$

where  $\Delta \underline{g}$  is the deviation of any one of the principal components from the free spin value ( $\underline{g}_e$ ) and the summation is over all the atoms (i) in the radical;  $\rho_i$  is the spin density on atom (i), and  $\eta_i$  is the spin-orbital coupling constant for that atom.  $\Delta E_i = E_{oi} - E_{ni}$ , where  $E_{oi}$  is the energy of the singly occupied orbital and  $E_{ni}$  is that of some other orbital on atom (i).

Increased deviations from the value of  $\underline{g}_e$  can then be expected if the spin density ( $\rho_i$ ) increases on atoms with large spin-orbit coupling constants ( $\eta_i$ ). As  $\eta_i$  generally increases with increasing atomic number, large deviations will be observed from radicals containing heavy atoms, provided the energy difference  $\Delta E_i$  remains fairly constant. Since  $\Delta E_i = (E_{oi} - E_{ni})$ , mixing with an orbital of higher energy will give a value of  $\Delta \underline{g} < 0$  whereas mixing with an orbital of lower energy will give a  $\Delta \underline{g} > 0$ . The deviation of the isotropic  $\underline{g}$ -value from  $\underline{g}_e$  will be given as the average of deviations of each of the principal components.

In practice, it appears that  $\underline{g}$  for  $\pi$ -radicals is usually greater than the free-spin value and may be dominated by the contribution from one particular substituent. Such an effect may be useful for assignment purposes. In contrast, for  $\sigma$ -radicals  $\underline{g}$  is usually less than the  $\underline{g}_e$  value.<sup>4</sup>

The  $\underline{g}$ -value of a radical can vary with changes in both solvent and temperature. The variation of  $\underline{g}$  with solvent can be the greater of the two, particularly if the radical is polar and there are specific

radical-solvent interactions. For example, p-benzosemiquinone radical-anion shows g-values of 2.00450 at -66 °C and 2.00468 at 23 °C in butanol<sup>5</sup>, whereas in water g was 2.00466 and in DMSO was 2.00518 at 20 °C.<sup>6</sup> Similarly, the g-value of di-*t*-butyl nitroxide at 20 °C changes from 2.00556 in water to 2.00614 in hexane.<sup>7</sup>

Table 1.1

g-Values of some organic radicals

<u>Radical</u>	<u>g</u>
Triphenylmethyl	2.002588 <sup>5</sup>
Naphthalene radical-anion	2.002752 <sup>5</sup>
Diphenylpicrylhydrazyl	2.00354 <sup>8</sup>
Benzyl	2.00263 <sup>9</sup>
Benzoyl, PhCO	2.0006 <sup>10</sup>

Table 1.2

Typical g-values for nitroxides R<sup>1</sup>R<sup>2</sup>NO<sup>9</sup>

<u>R<sup>1</sup></u>	<u>R<sup>2</sup></u>	<u>g</u>
Alkyl	Alkyl	2.0060 - 2.0063
Alkyl	Aryl	2.0055 - 2.0057
Aryl	Aryl	2.0055 - 2.0057
Alkyl	CCl <sub>3</sub>	2.0070 - 2.0071
Alkyl	Acyl	2.0067 - 2.0070
Alkyl	Alkoxy	2.0050 - 2.0054
Acyl	Acyl	2.0073

### Hyperfine Structure

Much information about free radicals in solution, given by an e.s.r. spectrum, comes from the "hyperfine structure". The effect arises from the interaction of the unpaired electron with those nuclei in the radical which have non-zero spin, e.g.  $^1\text{H}(I = \frac{1}{2})$ ,  $^2\text{H}(I = 1)$ ,  $^{14}\text{N}(I = 1)$ ,  $^{15}\text{N}(I = \frac{1}{2})$ ,  $^{19}\text{F}(I = \frac{1}{2})$ ,  $^{35}\text{Cl}$  and  $^{37}\text{Cl}(I = \frac{3}{2})$  (where  $I =$  nuclear spin quantum number). The type of coupling observed from free radicals in solution is isotropic and attributed to a net unpaired electron spin density at the nuclei. All anisotropic dipole-dipole effects are averaged to zero due to the rapid tumbling of the radical in the magnetic field.

The simplest system exhibiting a nuclear hyperfine interaction is the hydrogen atom. The single proton nucleus has spin  $I = \frac{1}{2}$  giving two allowed energy levels,  $M_I = \pm \frac{1}{2}$  in a magnetic field. The levels are approximately equally populated at room temperature due to their small energy separation. Thus the electron will experience one of the two possible local fields contributed by the proton and resonance will occur at two values of external magnetic field, with equal probability. The two resonant field values are given by

$$\underline{H} = \underline{H}_0 \mp \frac{a}{2} = \underline{H}_0 - \frac{aM_I}{I}$$

where  $\underline{a}$  is the spacing of the two hyperfine lines and is called the hyperfine splitting constant (in units of magnetic field) as opposed to the hyperfine coupling constant ( $A$ ) (in units of frequency). To





In general, with  $n$  equivalent protons  $n + 1$  lines are obtained, their relative intensities being the coefficients of the binomial expansion of  $(1 + x)^n$ . For  $m$  non-equivalent protons the maximum number of lines generated will be  $2^m$ , if all the splitting constants differ and there is no overlapping of lines. The overall width of a spectrum is  $2 \sum_i I_i a_i$ , the summation being over all nuclei.

The Origin of Hyperfine Splitting in Aromatic  $\pi$ -Radicals containing Hydrogen and Fluorine.

Earlier it was said that the isotropic hyperfine coupling from free radicals in solution was ascribed to a net spin density at the nucleus concerned. It is possible that this net spin density is of the same or opposite spin to that of the unpaired electron, and is called a "positive" or "negative" spin density, respectively. The spin density at a nucleus depends on the mechanism of spin transfer through the radical. Also, positive and negative splitting constants are defined, the sign being the same as that of the spin density if the gyromagnetic ratio is positive.

The hydrogen atoms of a benzene ring are in the nodal plane of the carbon  $\pi$ -orbitals. Thus if an unpaired electron is contained in a  $\pi$ -orbital of the ring then spin density cannot be directly transferred to the protons. Instead, 'spin-polarisation' of the C-H bond is the effective mechanism<sup>1</sup> and structure I has slightly greater probability than II from the  $\sigma$ - $\pi$  interaction and is predicted by Hund's Rules.

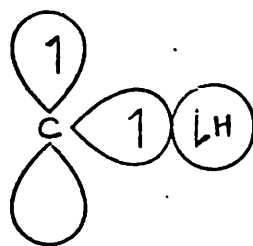

(I)

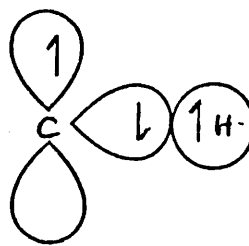

(II)

Hence the proton will experience a net negative spin density. For fluorine, however, there are two main mechanisms of spin transfer,  $1e$  spin polarisation (as above) and partial C-F  $\pi$  overlap (illustrated below).

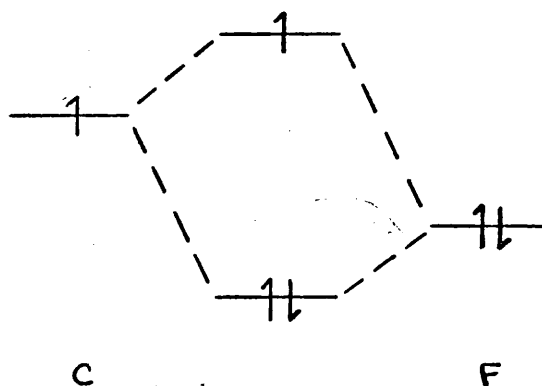
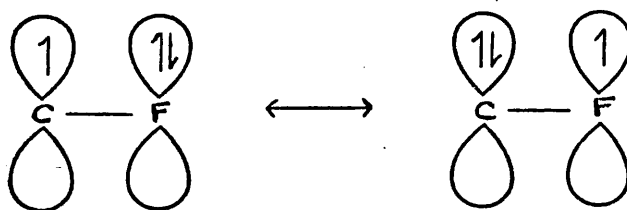

The  $\pi$ -bonding mechanism usually dominates over the  $\sigma$ -spin polarisation and a net positive spin density results.

The sign of a proton hyperfine splitting can be obtained from the direction of shift in n.m.r. resonance for the protons in the radical compared with the diamagnetic parent compound.<sup>1</sup> Molecular orbital calculations and experiments show that the spin density ( $\rho$ ) distribution in a phenyl nitroxide is as follows:

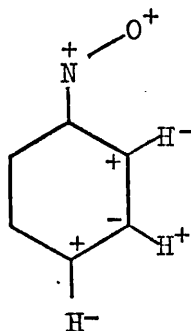

$$|\rho_o^H| \approx |\rho_p^H| > |\rho_m^H|$$

and

$$|a_o^H| \approx |a_p^H| > |a_m^H|$$

If the ortho-positions contain bulky groups or the other nitrogen substituent is large then the nitroxide group is forced out of the plane of the ring and the relative magnitudes of the proton splittings change<sup>63,64</sup> to  $|a_o^H| \approx |a_m^H| > |a_p^H|$ . Molecular orbital calculations predict this variation but it is uncertain whether the major route of transfer of spin through the ring skeleton is now through the  $\sigma$  or the  $\pi$  bonds.<sup>63</sup> For fluorine substitution in an aryl nitroxide where the nitroxide group is not twisted out of the plane of the ring the distribution is,

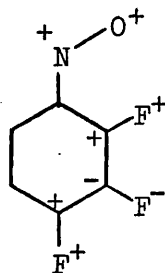

$$|a_o^F| \approx |a_p^F| > |a_m^F|$$

and the fluorine splitting is of the same sign as that of the adjacent carbon atom, showing that the partial double bonding mechanism of spin distribution to F is dominant. However, if the nitroxide group is twisted out of the plane of the ring the fluorine splittings all

become of similar magnitude (Section 3.13) and the meta-F coupling changes sign,<sup>65</sup> showing that the  $\sigma$ -distribution mechanism through the carbon skeleton has been enhanced and now the spin density transferred by spin-polarisation of C-F is of similar magnitude to that from the partial double bonding mechanism.

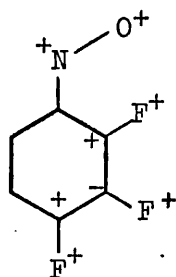

$$|\underline{a}_O^F| \approx |\underline{a}_m^F| \approx |\underline{a}_p^F|$$

For example,  $\underline{a}_m^F = -0.94$  G in 3-fluorophenyl-t-butyl nitroxide whereas  $\underline{a}_m^F = +1.26$  G in 5-fluoro-2-methylphenyl-t-butyl nitroxide.<sup>65</sup> Other examples are given in Tables 2.3, 3.6 and 3.7 and the effect is used in the assignment of radical structures (see Section 3.13).

### Linewidths

The analysis of the shape of e.s.r. absorptions can yield information about time-dependent phenomena. The width of an absorption may be expressed in terms of the Heisenberg uncertainty principle in the form:

$$\underline{\Delta E} \tau = \frac{h}{2\pi}$$

$$\Delta\nu = \frac{\underline{\Delta E}}{h} = \frac{1}{2\pi\tau}$$

where  $\tau$  is the relaxation time, and  $\Delta E$  and  $\Delta \nu$  are the uncertainties in the transition energy and frequency, respectively. Thus the linewidth is determined by the relaxation time,  $\tau$ , which contains two parts, the spin-lattice ( $T_1$ ) and spin-spin ( $T_2$ ) relaxation times.

$$\frac{1}{\tau} = \frac{1}{T_1} + \frac{1}{T_2}$$

For organic radicals in the liquid phase, the spin-lattice interaction is weak and has little effect on the linewidth.  $T_2$ , however, is an efficient process, particularly for electron spin-electron spin interaction. Consequently, the linewidth is dependent upon the radical concentration.

Chemical processes can produce e.s.r. line broadening if they alter the magnetic environment of the unpaired electron. These processes are usually exchange reactions, such as electron or proton transfers, which effect the spectrum if the frequency of exchange is comparable to the difference in resonance frequencies for the different environments (ca.  $10^{-7}$  Hz).

Variation in linewidth within the spectrum of a radical is known. The effect can arise from time-dependent hyperfine splittings (arising both from chemical processes and from conformational changes) and from a decrease in the tumbling rate in solution. As the tumbling rate decreases the anisotropic interactions are no longer averaged to zero

and the spectrum begins to resemble that for a randomly oriented solid. The effect is illustrated by the example of the di-*t*-butyl nitroxide radical<sup>61</sup> in media of different viscosity (Figure 1.1). An example of the effect for a radical containing two equivalent nitrogen atoms (the *p*-dinitrobenzene radical-anion) has been analysed in detail,<sup>62</sup> and may be used to predict the sign of nitrogen hyperfine coupling.

Figure 1.1

E.s.r. spectrum of di-t-butyl nitroxide in media of different viscosity.<sup>61</sup>

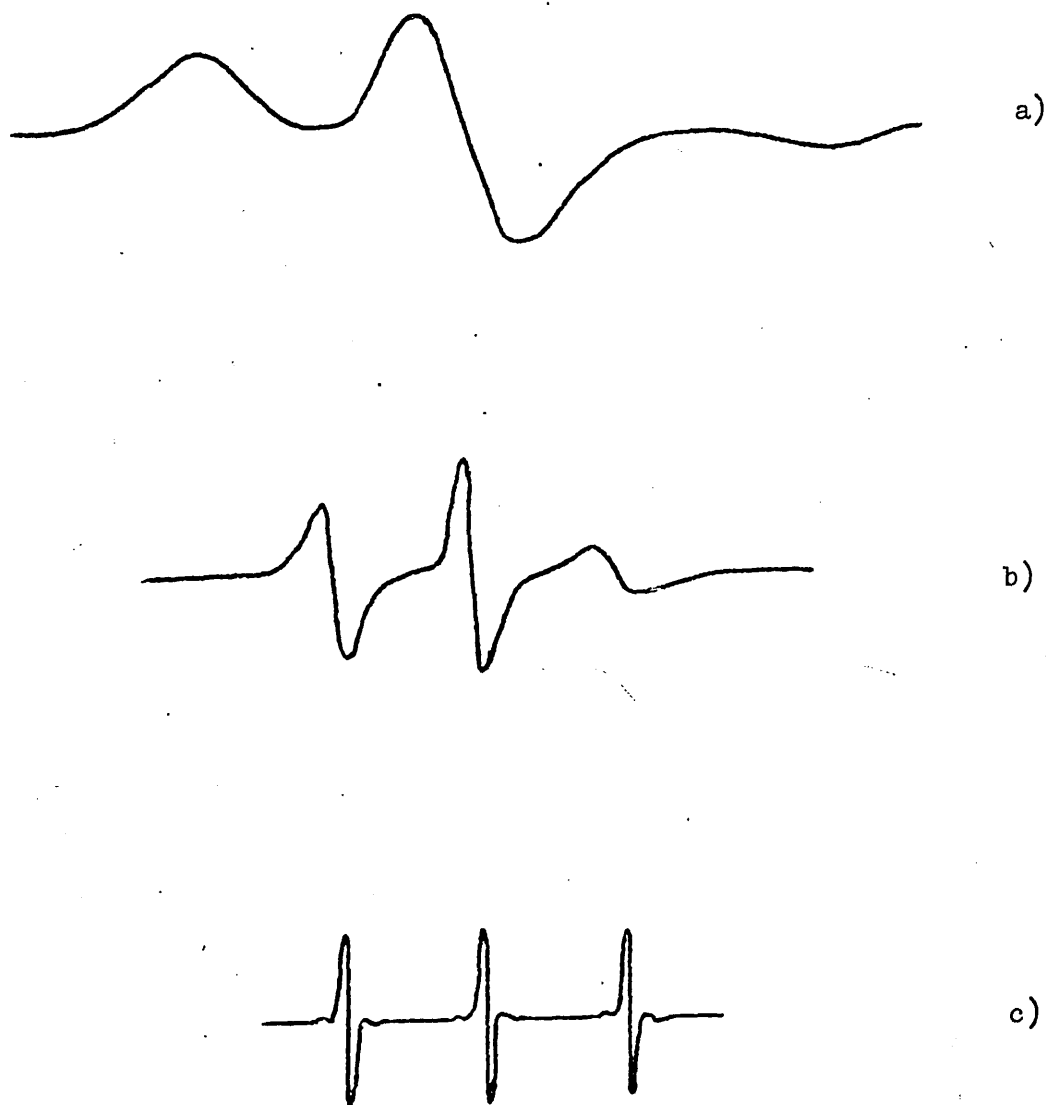

a) At 77 K (solid), b) at 142 K (viscous ethanol solution), c) at 292 K (low viscosity).

Section 1.2

C-Nitroso-Compounds

As this research is concerned with the reactions of C-nitroso-compounds, R-N=O, particularly aromatic C-nitroso-compounds, an introduction to their properties is relevant.

The nitroso-substituent in aromatic systems acts as an electron acceptor. This is indicated by the resonance structures:

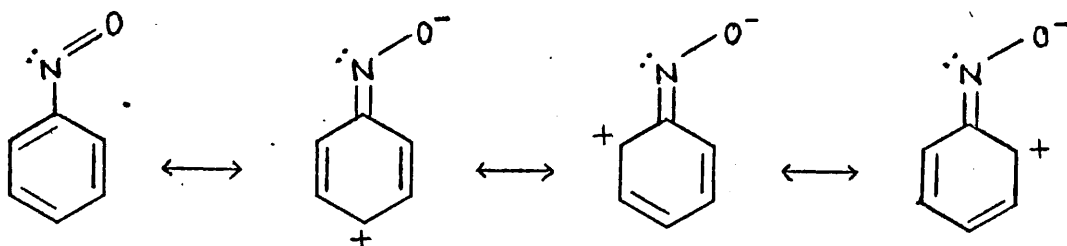

and confirmed by the dipole moment of 3.2 D.<sup>11</sup>

A tendency towards dimerisation is a distinctive property of the nitroso group when attached to carbon. The dimer is usually colourless and the stable form in the solid state. In solution an equilibrium between the two forms is established, the position of equilibrium depending upon the substituents.<sup>11</sup> Both aromatic and aliphatic C-nitroso-compounds form dimers. The dimeric structure has been established to be either a cis or trans N,N'-azodioxide [ or O-nitrosobis(trifluoromethyl) hydroxylamine in the case of trifluoronitrosomethane ] by X-ray crystallography.<sup>12,13</sup>



For example, nitrosomethane:<sup>14,15</sup>

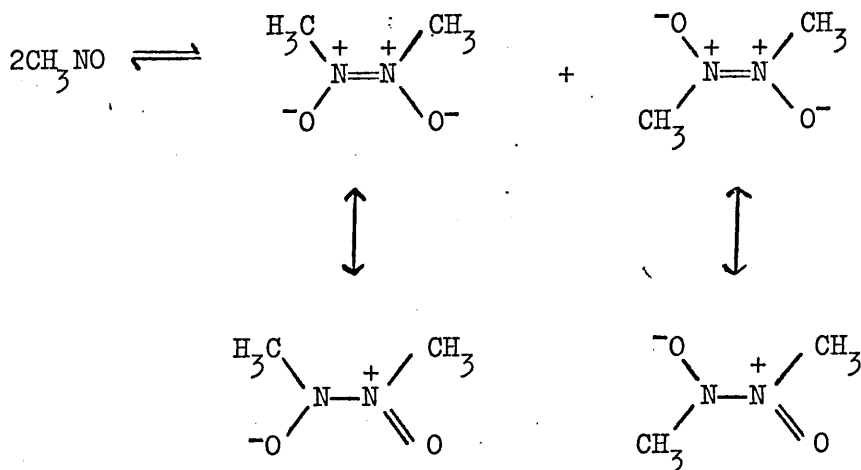

C-Nitroso-compounds are blue or green in the monomeric state, depending upon the solvent. The colour originates from an  $n \rightarrow \pi^*$  transition with weak absorption in the 6300 - 8300 Å range ( $\epsilon = 1$  to 60).

The monomer-dimer equilibrium may be shifted towards the monomer by substitution with electron releasing substituents. For example nitrosobenzene forms the monomer much more rapidly upon dissolving than does 2-methyl-2-nitrosopropane. p-Dimethylamino- and p-iodo-nitrosobenzene are monomeric in the solid state. Dimer dissociation has been shown to be electron demanding, showing a Hammett  $\rho$  value of -1.5 for para substituents.<sup>16</sup> Stabilisation of the dimer is achieved by ortho-substitution. This ortho-group effect may be attributed to either steric inhibition of resonance in either the monomer<sup>17</sup> or the dimer (resulting in a stronger N-N bond).<sup>18</sup>

The base-catalysed reaction between an activated methylene group and an aromatic  $\alpha$ -nitroso-compound is known as the Ehrlich-Sachs reaction.<sup>19</sup> It is thought to be initiated by nucleophilic attack by the corresponding carbanion on the nitroso-group. The mixture of products obtained may include an anil, nitron, azoxy-compound or amine depending upon the conditions of reaction.

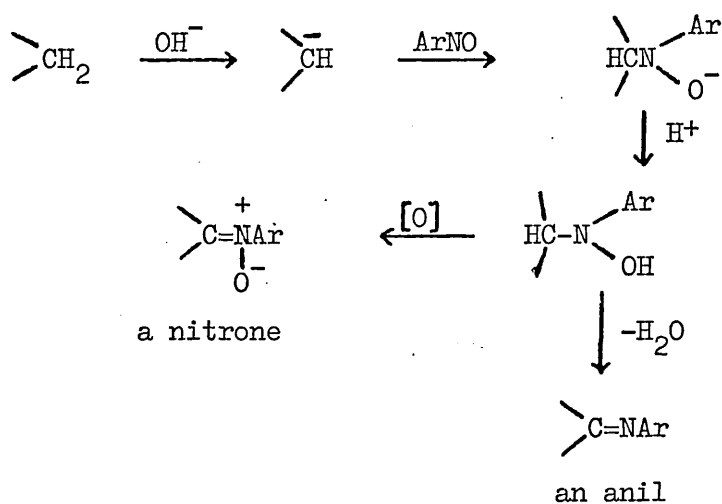

The generation of the azoxy-compound may proceed by the action of the base upon the nitroso-compound (see Section 1.4). The catalysts used include sodium alkoxides, aqueous alkali, piperidine or potassium cyanide. Typical methylene group compounds include benzyl cyanide, 2,4-dinitrotoluene, certain cyclopentadiene derivatives and heterocycles such as indole.

Benzyl and certain other halides also condense with aromatic nitroso-compounds, in the presence of base to give nitrones. It has been suggested that a mechanism involving initial attack by either a carbanion or a carbene may occur:

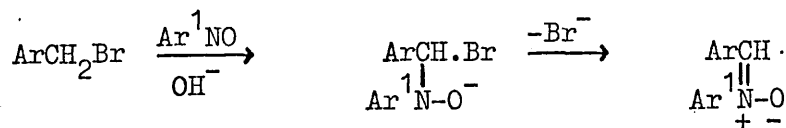

The presence of base is not required for the reaction between p-nitrosodimethylaniline and 1,2-dibromoethane. The corresponding bis-nitrone is the product.

The above reaction has been put to synthetic use in the preparation of aldehydes. The reaction is modified by using the pyridinium salt of the alkyl halide, and the nitrone formed is hydrolysed to give the corresponding aldehyde. The synthesis is known as the Kröhnke reaction.<sup>21,22</sup>

The mechanism proposed is:

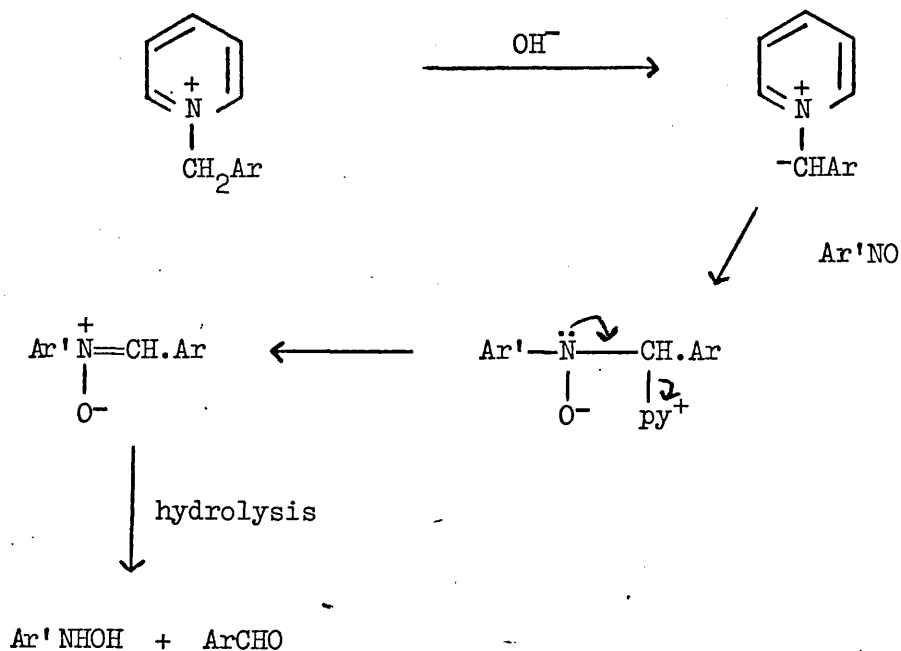

Section 1.3

Spin Trapping

Apart from being reactive towards nucleophiles, C-nitroso-compounds react readily with short-lived free radicals to generate nitroxides (aminyloxides), which are usually long-lived:

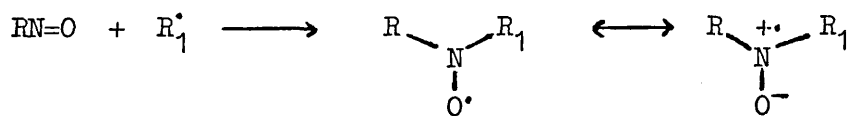

This reaction forms the basis of the so called 'spin-trapping' technique,<sup>23,24,25</sup> where a nitroso-compound is used to detect possible radical intermediates in a reaction. Nitroxides constitute one of the most kinetically stable classes of radical known, hence a relatively high concentration of the spin adduct builds up and is readily detectable using e.s.r. spectroscopy. If the nitroxide formed can be identified from its spectrum, then the identity of the scavenged radical may be deduced. Thus the ideal scavenger would be one in which the hyperfine splitting, and to some extent the  $g$ -value, of the adduct radical would depend upon the radical scavenged. In this respect C-nitroso-compounds are better spin traps than nitrones (Equation (vi)) in that the trapped radical occupies a site closer to the generated radical centre.

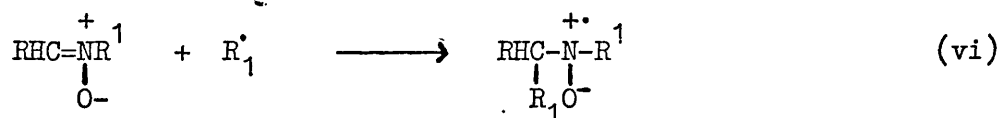

The most useful C-nitroso-compounds employed as spin traps are 2-methyl-2-nitrosopropane, its fully deuterated analogue,<sup>26</sup> 2-methyl-2-

nitrosobutanone,<sup>27</sup> and some substituted aromatic nitroso compounds.<sup>28,29</sup>

The main disadvantage of the method is that the efficiency and success of the trapping reaction depends on many factors, and a negative result cannot be taken as definite proof of the absence of free radicals. The possibility of side-reactions (homolytic or heterolytic) must also be taken into account. For example, nucleophilic addition followed by one-electron oxidation of the hydroxylamine derivative formed, will yield a nitroxide:<sup>30</sup>

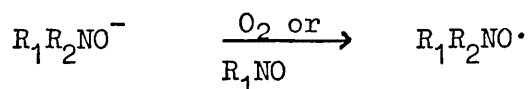
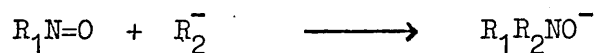

Thus detection of a nitroxide does not definitely allow the conclusion that an intermediate radical  $R_2^\cdot$  exists.

Another complicating feature of the use of C-nitroso-compounds as spin traps is their thermal and photochemical instability, generating the corresponding symmetrical nitroxide:

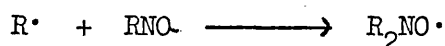
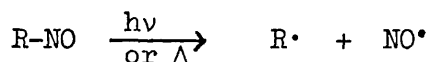

Section 1.4

The Reduction of C-Nitroso-Compounds

Bamberger first showed that nitrosobenzene is readily reduced by base (sodium methoxide in methanol, sodium ethoxide in ethanol) to give high yields of azoxybenzene.<sup>31</sup>

More recently Russell et al<sup>32</sup> found, using e.s.r. spectroscopy, that paramagnetic intermediates are formed in the reactions of nitrosobenzene with N-phenylhydroxylamine. In deoxygenated and strongly basic solution an essentially quantitative yield of the nitrosobenzene radical-anion was observed from this reaction. In the absence of added base, low concentrations of phenyl nitroxide (PhNHO•) were detected over a period of hours, even in the presence of oxygen, and from the reaction mixture high yields (> 90%) of azoxybenzene were obtained. From kinetic and e.s.r. results the following mechanism in basic solution was suggested:

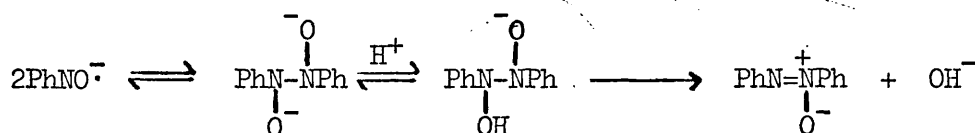

This mechanism accounts for the formation of all the possible azoxybenzene derivatives from the reaction of Ar<sup>1</sup>NHOH with Ar<sup>2</sup>NO.

Reduction of nitrosobenzene itself has been shown by e.s.r. to generate the radical-anion. The one-electron reduction may be achieved electrochemically<sup>33</sup>, or by using titanium III in acid solution (to give PhNHO•) or in strongly basic media<sup>33,34,35</sup> (the mechanisms proposed are given later in this section.)

The e.s.r. splitting constants of the nitrosobenzene radical-anion were found to exhibit marked solvent dependence.<sup>33</sup> Also the two ortho-hydrogens are not equivalent,<sup>33,37</sup> and in liquid ammonia solution it is possible to distinguish magnetically all five hydrogens in the radical-anion.<sup>38</sup>

When the basic nitrosobenzene solutions were exposed to oxygen the e.s.r. spectrum of the nitrobenzene radical-anion was observed,<sup>32,39</sup> after the nitrosobenzene had been consumed. Also, if the reaction mixture contained acetone (see Section 2.1A), the nitrobenzene radical-anion signal was observed initially, in place of that of the nitroso-radical-anion.<sup>33</sup>

A fourth spectrum from the (nitrosobenzene + base) reaction has been observed using sodium methoxide and nitrosobenzene in deoxygenated methanol in a flow system.<sup>33</sup> The splitting constants observed were 11.5 G (1N), 2.4 G (3H) and 0.9 G(2H). A similar spectrum has been observed in the azobisisobutyronitrile induced oxidation of aniline<sup>40</sup> and in the reaction of t-butyl hydroperoxide with N-phenylhydroxylamine, or triphenylhydrazine.<sup>41,42</sup> The spectrum has been assigned to the N-hydroxy-N-phenylamino radical,<sup>42</sup> or to a rapid tautomeric equilibrium mixture:<sup>40</sup>

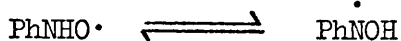

The assignment of the spectrum has been confused by the observation<sup>39</sup> of a similar spectrum from the reaction of sodium dithionite with

nitrosobenzene in acetic acid solution. Russell<sup>39</sup> proposed the structure (III) for the radical formed as shown below:

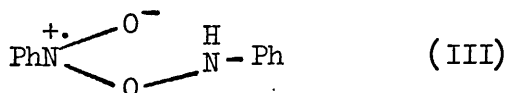
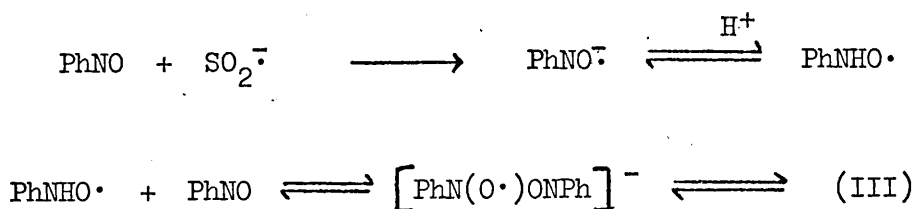

However, it has since been shown by Waters<sup>43</sup> that the radicals observed by Russell et al. are formed by the addition of  $\text{SO}_2^{\cdot-}$  to nitrosobenzene:

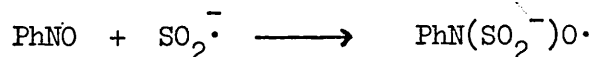

The authors of a recent paper<sup>44</sup> on N-alkoxy-N-arylaminy radicals have recognised the similarity of the hyperfine splittings to those of a phenyl nitroxide and their incompatibility with an N-hydroxy-N-phenylamino-structure.

Russell et al.<sup>39</sup> have studied the reaction of nitrosobenzene with hydroxide or alkoxide ions in a series of alcohols and have observed the e.s.r. spectrum of the nitrosobenzene radical-anion. Azoxybenzene was the major product (65 - 70% yield) and no nitrobenzene was formed (as determined by g.l.c.) when the reaction was performed



under nitrogen. Similar results were obtained with dimethylsulphoxide (DMSO) as solvent, except that the radical-anion was observed in higher concentration. A mechanism was suggested:

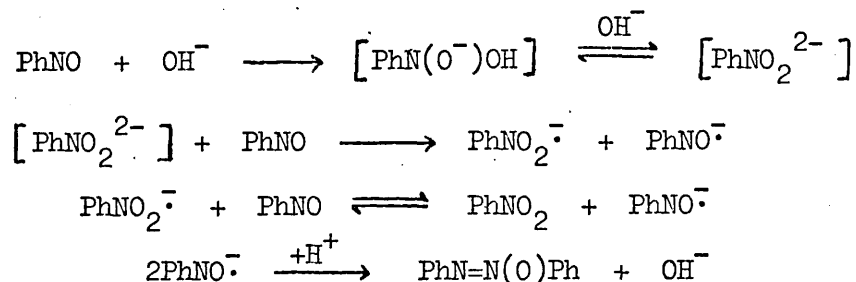

However, as they did not detect nitrobenzene in the absence of oxygen, they suggested hydroxide ion may add to the aromatic ring instead, eventually leading to a quinonoid structure that would be destroyed by base. In the presence of stoichiometric amounts of oxygen, nitrobenzene becomes the major product at the expense of azoxybenzene.

Hutton and Waters<sup>45</sup> investigated the reaction of nitrosobenzene with base in alcoholic solution in more detail. They ruled out the possibility of the reaction occurring by means of attack of base at a ring position in nitrosobenzene because they did not detect any trace of 4,4'-di-*t*-butoxyazoxybenzene from reactions in alkaline *t*-butyl alcohol. They found a primary kinetic isotope effect ( $k_{\text{H}}/k_{\text{D}} = 3.3$ ) for reductions using cyclohexanol and 1- $d_1$ -cyclohexanol, which suggested either hydride transfer or hydrogen atom transfer. With benzyl alcohol or benzhydrol, oxidation gave high yields of the corresponding carbonyl compound. With aliphatic primary alcohols, however, the derived aldehydes are unstable in the alkaline medium used, and are

not observed.

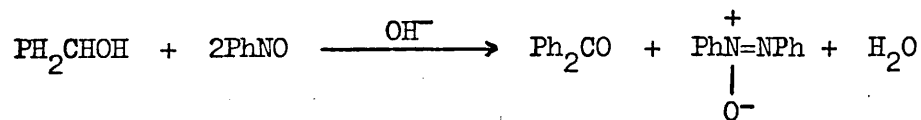

Benzpinacol (IV), which would result from hydrogen atom transfer, could not be detected:

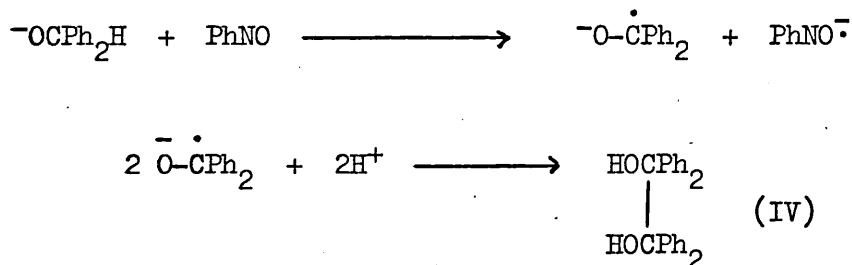

The mechanism proposed<sup>45</sup> was, therefore, one of hydride transfer from the alcohol:

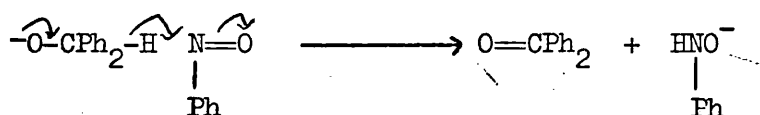

or a concerted step:

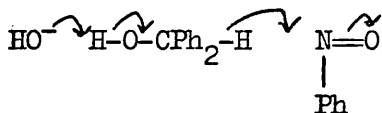

followed by the radical reactions between the phenylhydroxylamine anion formed and nitrosobenzene as proposed by Russell.<sup>32,39</sup> However,

recently a different mechanism has been proposed<sup>46</sup> supported by the results of an investigation<sup>46</sup> of the kinetics of the reaction of *p*-substituted-nitrosobenzenes with methoxide in methanol. In agreement with previous work azoxybenzene derivatives were the major products unless oxygen was present, when oxidation to a nitro-compound was observed.

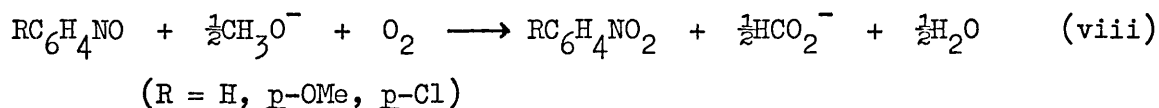
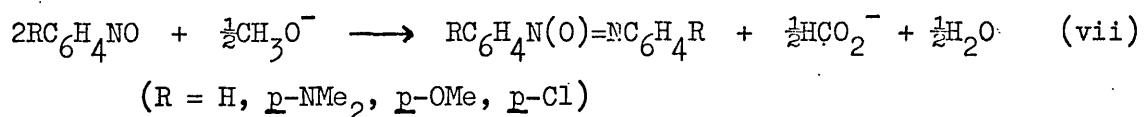

A Hammett plot using measured rate constants gave  $\rho = 3.88 \pm 0.46$  (correlation coefficient 0.96) for reaction (vii). This is consistent with development of a negative charge in the rate-determining transition state for the rate-determining step, which was thought to be the formation of (V).

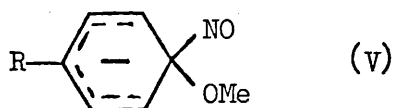

It was suggested that (V) decomposed to give  $\text{RC}_6\text{H}_4\text{NOH}$  and  $\text{CH}_2\text{O}^-$ . The complete mechanism proposed for reaction (vii) is shown below.

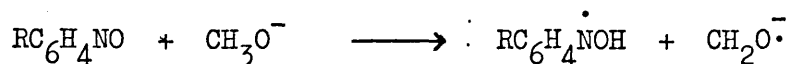

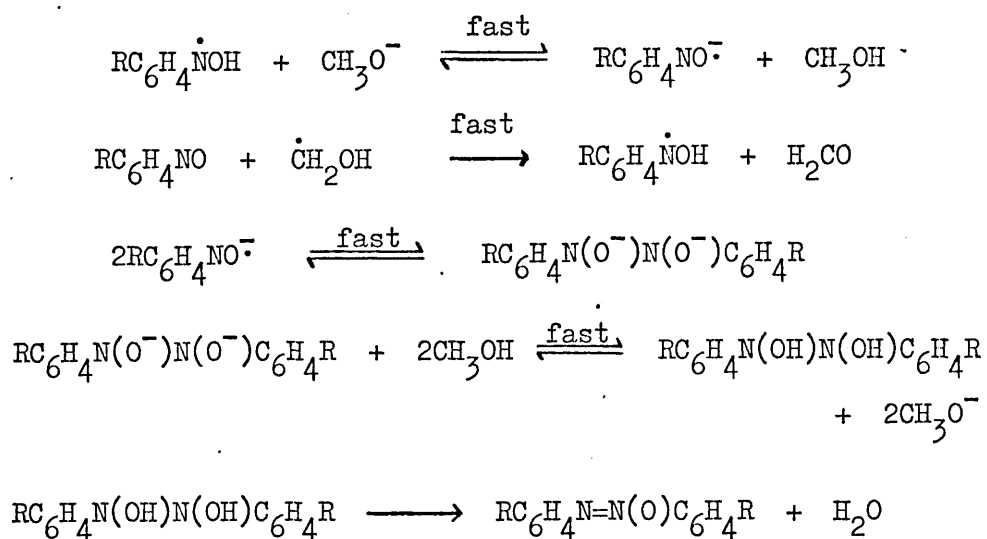

Similarly, for reaction (viii) the Hammett  $\rho$  value was  $3.97 \pm 0.31$  and the mechanism shown below was proposed.

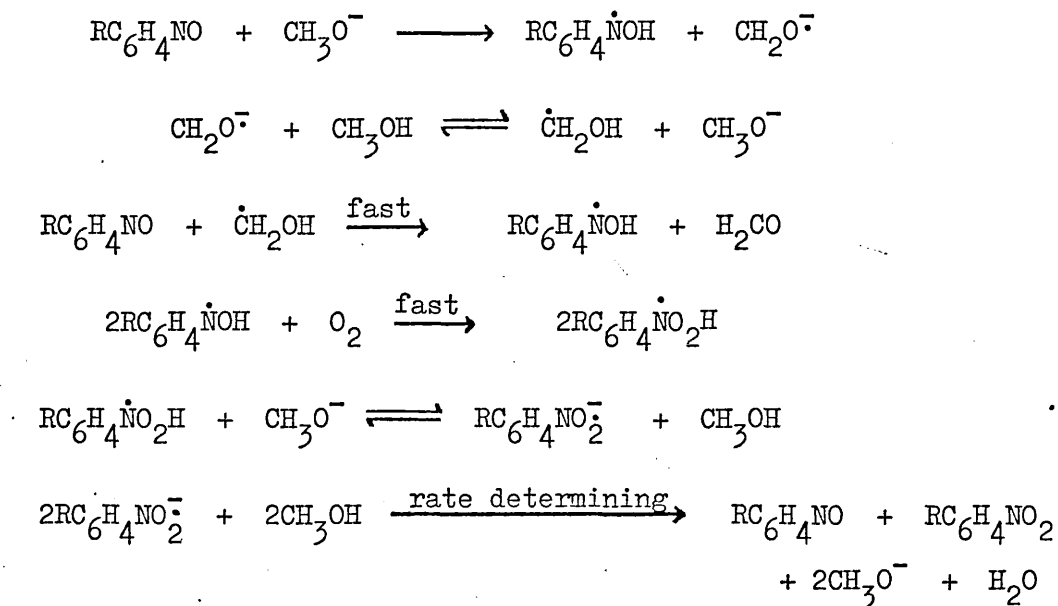

Thus, effectively, hydrogen atom transfer was proposed as the initial step in the reactions and no mention was made of the results of Hutton and Waters<sup>45</sup> and their hydride-ion transfer mechanism.

Aurich and Dersch<sup>47</sup> have investigated the action of potassium t-butoxide upon 2-methyl-2-nitrosopropane using e.s.r. In oxygen-free conditions they observed a 3-line spectrum, 11.2 - 12.6 G (1N) which they assigned to the 2-methyl-2-nitrosopropane radical-anion. A similar spectrum was also observed from the action of potassium t-butoxide on 2-methyl-2-nitrosopropane and N-t-butyl hydroxylamine in the absence of oxygen, and also on N-t-butylhydroxylamine in the presence of oxygen.

In the presence of oxygen the signals of the nitroso-radical-anion disappeared rapidly to be replaced by those of the corresponding nitro-radical-anion ( $a_N = 26.0 - 29.0$  G) and di-t-butyl nitroxide ( $a_N = 14.9 - 15.5$  G). Depending upon the solvent used additional signals from t-butyl aryl nitroxides or t-butyl alkyl nitroxides were also detected. The route of formation of  $Bu^tNO^-$  proposed was similar to the Russell mechanism for the generation of  $PhNO^-$ .

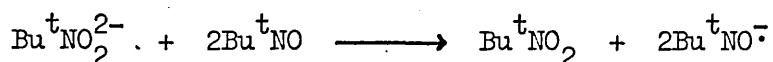
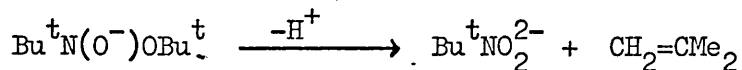

Reaction of the nitroso-radical-anion with oxygen was suggested, leading to formation of a short-lived peroxy-radical which was responsible for formation of the nitroxides observed:

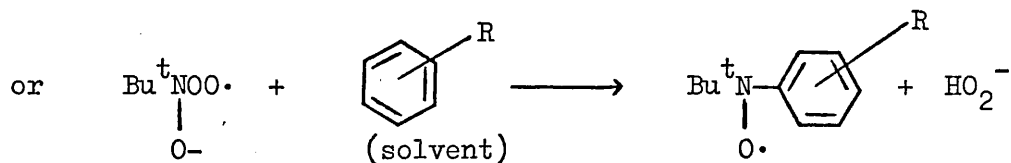
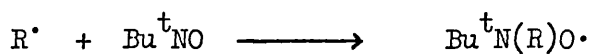
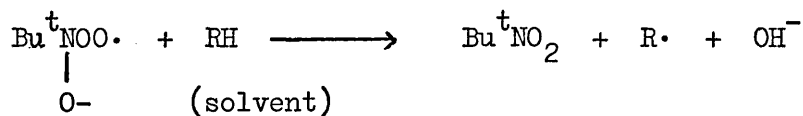
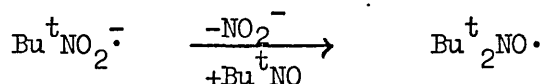
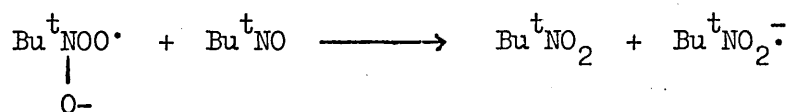
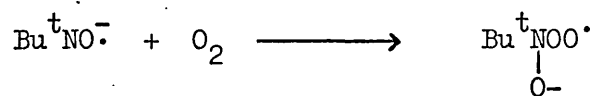

The last step was expanded upon:

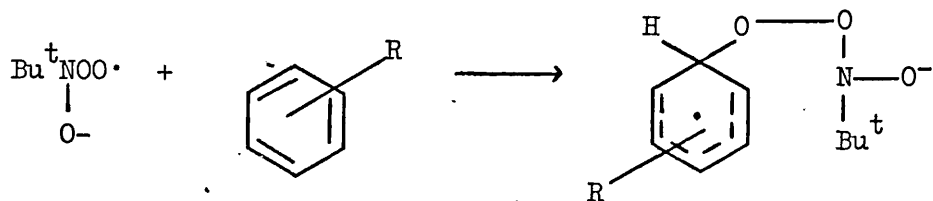

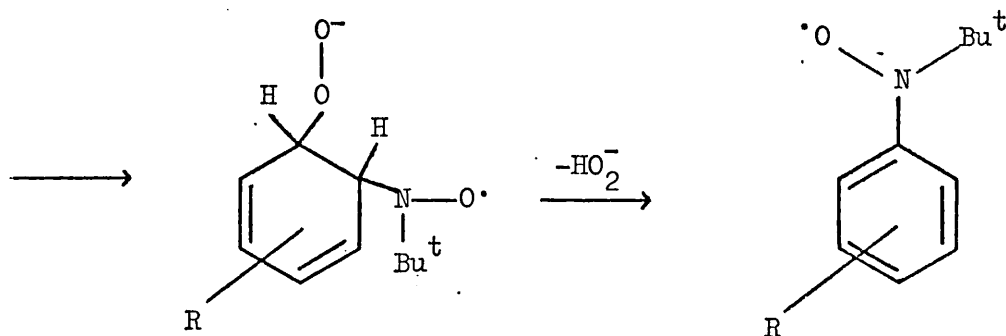

The importance of electron transfer processes and radical-anions in the mechanisms of organic reactions has become recognised over the past 20 years.

The transfer of an electron from a diamagnetic carbanion to a suitable acceptor was apparently first noticed by Schlenk<sup>48</sup>, who found that trityl-sodium reacts with benzophenone with characteristic colour changes to produce, upon hydrolysis and air oxidation, trityl peroxide and the pinacol.

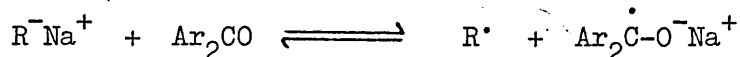

Russell et al.<sup>48,50</sup> have shown that electron transfer between carbanions and organic electron acceptors ( $\pi$ ), such as nitro-aromatic compounds often occurs readily.

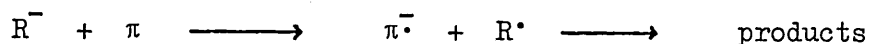

A similar process has been shown for dianions and their dehydro-derivatives:<sup>49</sup>

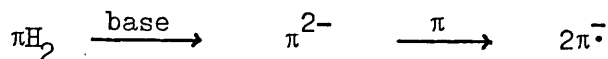

The reactions of radical-anions have been classified as involving three competitive routes;<sup>51</sup> nucleophilic reactions, electron transfer reactions and non-electron transfer homolytic reactions. For example, the radical-anion of naphthalene typically transfers electrons to alkyl halides<sup>51,52</sup> and superoxide ( $O_2^{\cdot-}$ ) acts as a one-electron reducing agent, an oxidising agent (usually to give  $H_2O_2$ ) or as a powerful nucleophile,<sup>53</sup> depending upon the reaction conditions.<sup>54</sup>

Important synthetic routes have been developed arising from the recognition of radical, radical-anion chain processes in certain substitution reactions (designated  $S_{RN}1$ ). Kornblum<sup>55,56</sup> has investigated the mechanism of the substitution reaction at a saturated carbon atom, and Bunnett<sup>57,58</sup> substitution at aromatic reaction sites. The reaction steps in common are:

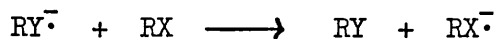
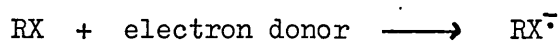

Kornblum<sup>55</sup> has shown the  $S_{RN}1$  reaction to be somewhat insensitive to steric effects. In certain examples competition between the  $S_{RN}1$  and  $S_N2$  processes was observed, and thus it was thought<sup>55</sup>



incorrect to regard S<sub>N</sub>2 displacement as involving an electron-transfer "component" as has been suggested.<sup>59</sup>

It has been reported<sup>60</sup> that the mechanism of the nucleophilic substitution of alkyl halides by sodium mercaptides (NaSR) may be free-radical in nature (S<sub>RN</sub>1). The evidence was based upon radical trapping experiments using C-nitroso-compounds and nitrones. The proposed mechanism was:

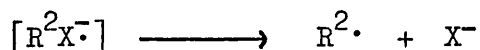
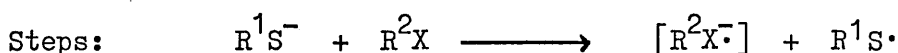
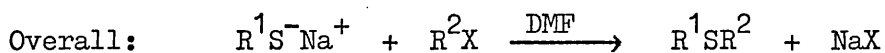

Chain

propagation

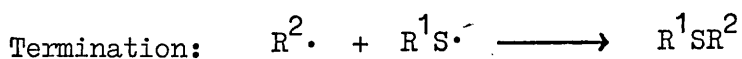
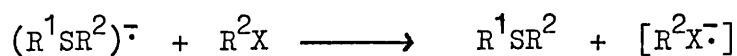
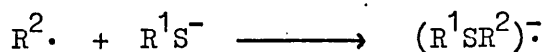

In the presence of a nitroso-'spin-trap' (R<sup>3</sup>NO), the dialkyl nitroxide R<sup>3</sup>N(R<sup>2</sup>)O· was observed.

Sulphur-centred radicals do not generate long-lived nitroxide adducts with C-nitroso-compounds but by using a nitrona a nitroxide was observed whose assignment indicated the trapping of a sulphur-centred radical. The reactions were carried out in the presence of atmospheric oxygen.

#### Scope of Present Work

In the above report<sup>60</sup> no account seemed to have been taken of the possibility of the addition of  $RS^-$  to the nitrona to give, on atmospheric oxidation, the corresponding nitroxide. Also the effect of bases on C-nitroso-compounds had been ignored. As outlined earlier, a radical-anion is usually generated and the action of aromatic thiolate anions on nitrosobenzene has been shown to yield the corresponding radical-anion.<sup>34</sup> This reaction might extend to aliphatic C-nitroso-compounds, for it is known that  $Bu^tNO^-$  is generated by the action of  $Bu^tO^-$  on  $Bu^tNO$ .<sup>47</sup> Therefore, the dialkyl nitroxides reported<sup>60</sup> may in fact be generated by the action of the nitroso-radical-anion on the alkyl halide.

Consequently, it was decided initially to investigate the reaction of bases other than mercaptides with alkyl halides in the presence of C-nitroso-compounds, to determine whether a nitroxide was formed and to determine its mechanism of formation.

In view of the mechanistic uncertainties about the reaction between nitrosobenzene and bases, generation of nitroso-radical-anions

directly by electrolytic reduction should simplify the investigation of the rôle played by the nitroso-radical-anion in the reaction. The use of electrolysis is made feasible by the use of a combined electrolysis and e.s.r. cell, which allows the reduction to be performed inside the microwave cavity of the e.s.r. spectrometer.

CHAPTER 2.

PARAMAGNETIC PRODUCTS OBSERVED BY E.S.R. SPECTROSCOPY FROM

THE REDUCTION OF SUBSTITUTED NITROSOARENES

Section 2.1

In order to study the reactions of substituted nitrosoarene radical-anions with alkyl halides it was first necessary to characterise the radical-anions by e.s.r. spectroscopy and determine suitable routes for their generation.

Initially nitrosobenzene and 2,4,6-tribromonitrosobenzene (VI) were investigated. (VI) was easily prepared and gave spectra with a simpler hyperfine splitting pattern than that of the nitrosobenzene radical-anion. Also, substitution with bulky ortho-groups may protect any nitrogen-centred radicals formed and concentrate the unpaired electron away from the aryl group by forcing the nitroso-group out of the plane of the ring.

The nitrogen and ring splittings from all the nitrosoarene radical-anions detected are very sensitive to the composition of the solvent (for example, Figures 2.9 and 2.12). In valence bond terms, structure (ix) becomes more favourable in polar, hydrogen-bonding solvents.

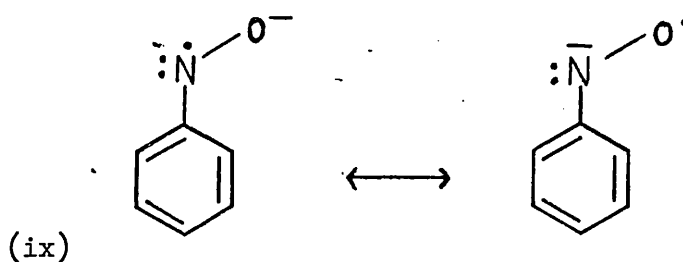

A list of the e.s.r. spectral parameters of the nitroso-radical-anions observed is given in Table 2.1. For comparison the corresponding nitro-radical-anion and nitrosylsulphinato-radical-anion  $[\text{ArN}(\text{SO}_2^-)\text{O}\cdot]$  spectral parameters are given in Tables 2.2 and 2.3 respectively.

### 2.1A Nitrosobenzene

In agreement with previous investigations<sup>33,34,35,39</sup> of the action of base on nitrosobenzene, its radical-anion was observed in the presence of excess base (aqueous sodium hydroxide, sodium methoxide, potassium t-butoxide or sodium hydride) in dimethylsulphoxide (DMSO) (Figure 2.1), dimethylformamide (DMF) or ethanol. The splitting constants (Table 2.1), agree with literature<sup>33,39</sup> values. In weakly basic solutions the radical-anion was protonated so that the spectrum of phenyl nitroxide ( $\text{PhNHO}\cdot$ , Figure 2.2) was detected. The splitting constants agree with literature<sup>35</sup> values:

10.50 G (1N)  
 13.25 G (1H)  
 3.25 G (2H)  
 3.50 G (1H)  
 1.15 G (2H)

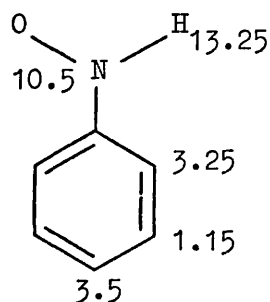

in ethanol solution.

After a time, when oxygen was present in the strongly basic solutions of nitrosobenzene, the spectrum of the nitroso-radical-anion was gradually replaced by that of the nitrobenzene radical-anion, as would be expected (Section 1.4). Similar results were obtained in the electrochemical

reduction of nitrosobenzene in DMSO at a mercury cathode. In the presence of oxygen the nitroso-radical-anion spectrum was recorded initially, but after a few minutes of current flow a mixture of the spectra of the nitro and nitroso radical-anions was recorded.

The spectrum assigned to  $\text{PhNOH}^{\cdot 42}$  or  $(\text{PhNOH} \rightleftharpoons \text{PhNHO}\cdot)^{40}$  (discussed in Section 1.4) was detected from the action of sodium methoxide on nitrosobenzene in DMSO (Figure 2.3).

When acetone formed part of the reaction mixture of nitrosobenzene, base and solvent, or was added after the start of the reaction, only the nitrobenzene radical-anion was detected (Figure 2.4). This effect was first observed by Ayscough *et al.*<sup>33</sup>

#### 2.1B 2,4,6-Tribromonitrosobenzene (VI)

The radical-anion from (VI) could be observed when aqueous 10% sodium hydroxide was added dropwise to (VI) in DMSO solution (Figure 2.5).

[ When alkali is added to solutions of nitrosoarenes ( $\text{ArNO}$ ,  $\text{Ar} = 2,6$ -dichloro-; 2,4,6-trichloro-; 2,6-dibromo- and 2,4,6-tribromo-phenyl), in DMSO only, a nitroxide is observed in high concentration. The splittings (for example, Figure 2.6) are from the  $\text{ArN-O}^{\cdot +}$  part of the radical and are very similar to those seen in the corresponding nitrosulphinate radical-anions,  $\text{ArN}(\text{SO}_2^-)\text{O}\cdot$  (Table 2.3) ].

On addition of solid sodium methoxide to a solution of (VI) in DMSO an intense red colouration was observed and a nitroxide was also detected (Figure 2.7), with splitting constants:

10.4 G (1N), 2.5 G (3H)

0.75 G (2H), 0.5 G (2H)

The simulated spectrum incorporates these values (Figure 2.7). The same spectrum was obtained from  $d_6$ -DMSO solutions suggesting that the quartet splitting comes from a methyl group derived from methoxide ion. The other splittings indicate the radical is a diaryl nitroxide, although the quartet splitting (2.5 G) is larger than would be expected from a sterically hindered nitroxide<sup>64</sup> and so the structure of the radical is uncertain.

The effect of acetone in determining which radicals were observed from (VI) depended upon whether it was the solvent or a co-solvent in low concentration. When 10% aqueous sodium hydroxide was added to (VI) in acetone two layers formed. The colourless aqueous layer gave a spectrum assigned to the corresponding nitro-radical-anion [ 21.55 G (1N), 0.65 G (2H) ] . This behaviour is similar to that observed for nitrosobenzene. The red organic layer also formed, gave a spectrum of a radical containing two magnetically equivalent nitrogen atoms [ 4.9 G (2N), 1.9 G (4H) ] discussed in Section 2.2.

When aqueous sodium hydroxide was added dropwise to (VI) in 10% acetone - DMSO a different spectrum (Figure 2.8) was observed, with splitting constants:

7.25 G (1N)

4.15 G (1H)

1.25 G (2H)

This spectrum is assigned to the radical-anion of 2,4- or 2,6-dibromonitrosobenzene. If the radical is the 2,6-dibromo isomer then the observed splitting constants should fit a plot of the nitrogen splitting versus the para-H splitting from the 2,6-dibromonitrosobenzene radical-anion in various solvents (Figure 2.9). As the values for the unknown radical-anion did not lie on this graph it was, therefore, held to be the 2,4-dibromonitrosobenzene radical-anion. The mechanism of debromination is discussed in Section 2.1F.

#### 2.1C. 2,6-Dibromonitrosobenzene (VII)

The radical-anion of 2,6-dibromonitrosobenzene was readily observed in DMSO or DMF solution when aqueous sodium hydroxide or sodium methoxide was added (Figure 2.10). However, when an excess of sodium methoxide was added the radical-anion spectrum was replaced by a spectrum having the splitting constants:

8.75 G (1N)

1.20 G (2H)

3.85 G (1H)

4.00 G (1H)

The values varied markedly with the composition of the solvent; the spectrum was assigned to the 2-bromonitrosobenzene radical-anion (see



Figure 2.9 A plot of  $\underline{a}_N$  versus  $\underline{a}_{p-H}$  for the 2,6-dibromonitrosobenzene radical-anion in various solvents. The unknown dibromonitrosobenzene radical-anion point is marked by X.

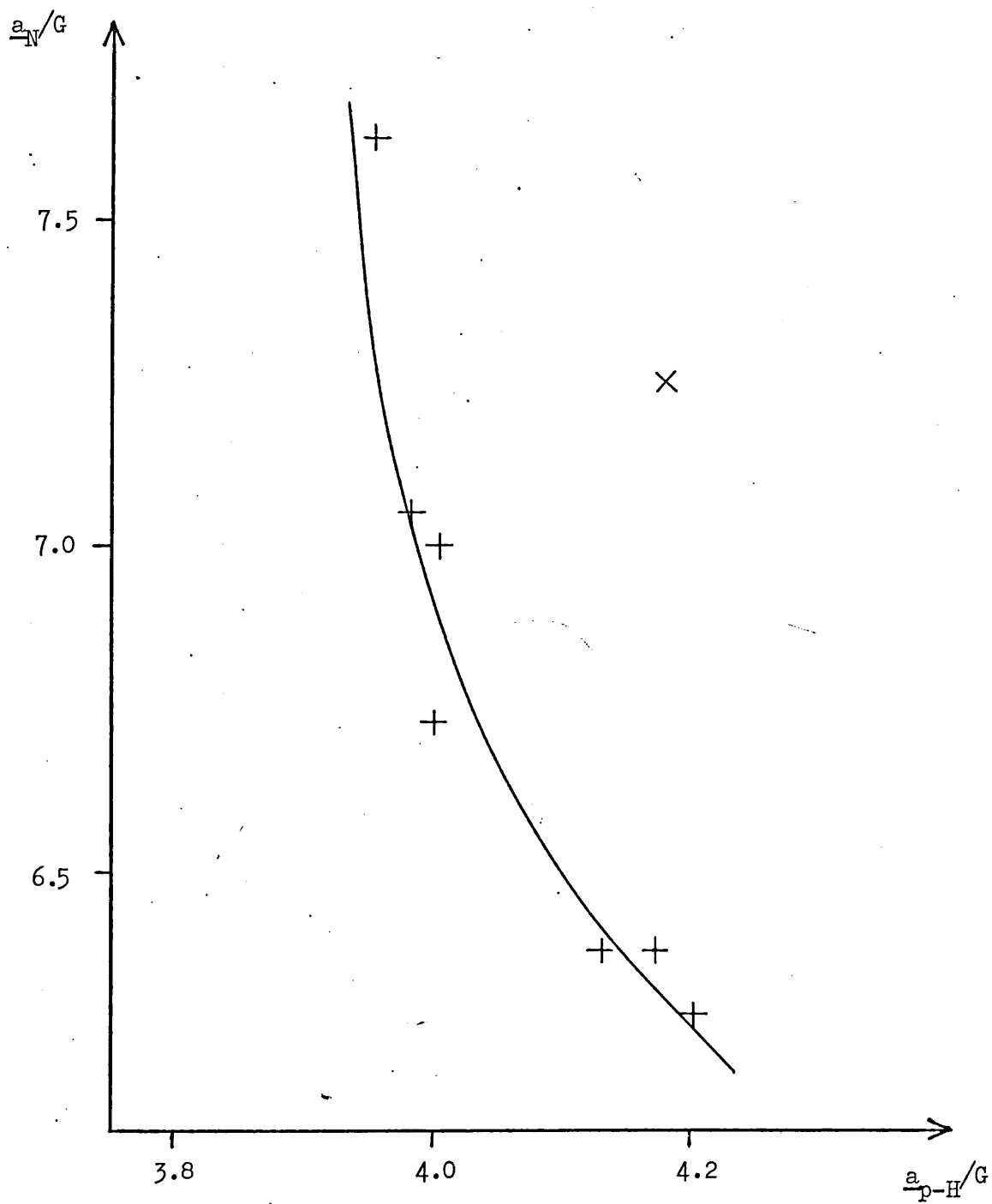

Section 2.1F).

The dimeric radical-anion with  $a_N$  ca. 4.8 G (2N) although observed in basic solutions of the other chlorine and bromine substituted nitrosobenzenes, was not detected with (VII).

#### 2.1 D. 2,4,6-Trichloronitrosobenzene (VIII)

The radical-anion of (VIII) was, observed when for example aqueous sodium hydroxide was added to (VIII) in 50% DMSO-ethanol.

In some reaction solutions the radical-anion spectrum was replaced by that of a dimeric species as discussed in Section 2.2.

Splitting constants:                    4.85 G (2N)  
    1.80 G (4H)

When ca. 10% acetone was added to the reaction mixture and aqueous sodium hydroxide was added, the radical-anion of the corresponding nitro compound or the dimer radical, was observed in place of the nitroso-radical-anion.

On electrochemical reduction at a mercury cathode in DMSO with tetra-n-butylammonium iodide as electrolyte the radical-anion of (VIII) was generated. However, after a longer period of current flow the initial spectrum was replaced by a spectrum assigned to a dichloronitrosobenzene radical-anion (Figure 2.11). This sequence of spectra was observed whether the electrolyte was deoxygenated or not. The splitting

constants [6.4 G (1N), 3.75 G (1H) and 1.20 G (2H)] of the dichloro-nitrosobenzene radical-anion did not lie on a plot of the nitrogen splitting constant versus the para-hydrogen splitting constant for the 2,6-dichloronitrosobenzene radical-anion in various solvents (Figure 2.12) and the spectrum is consequently assigned to the 2,4-substituted isomer.

#### 2.1 E. 2,6-Dichloronitrosobenzene (IX)

The radical-anion of (IX) was observed in high concentration when aqueous sodium hydroxide was added dropwise to solutions of (IX) in, for example, DMSO or in ethanol (Figure 2.13).

Electrochemical reduction of (IX) in DMSO solution also generated high concentrations of the radical-anion; only after prolonged electrolysis was a second radical detected (Figure 2.14). Assignment of the secondary radical is uncertain due to the close overlap of the spectra.

In DMSO solution with an excess of aqueous sodium hydroxide (IX) gave rise to a dimeric radical (Figure 2.15) with the splitting constants:

5.15 G (2N)  
1.90 G (4H)  
3.40 G (2H)

The simulated spectrum using these constants is given in Figure 2.15 with a peak-to-peak linewidth of 0.28 G.

Figure 2.12 A plot of  $a_N$  versus  $a_{p-H}$  for the 2,6-dichloronitrosobenzene radical-anion in various solvents. The unknown dichloronitrosobenzene radical-anion point is marked by X.

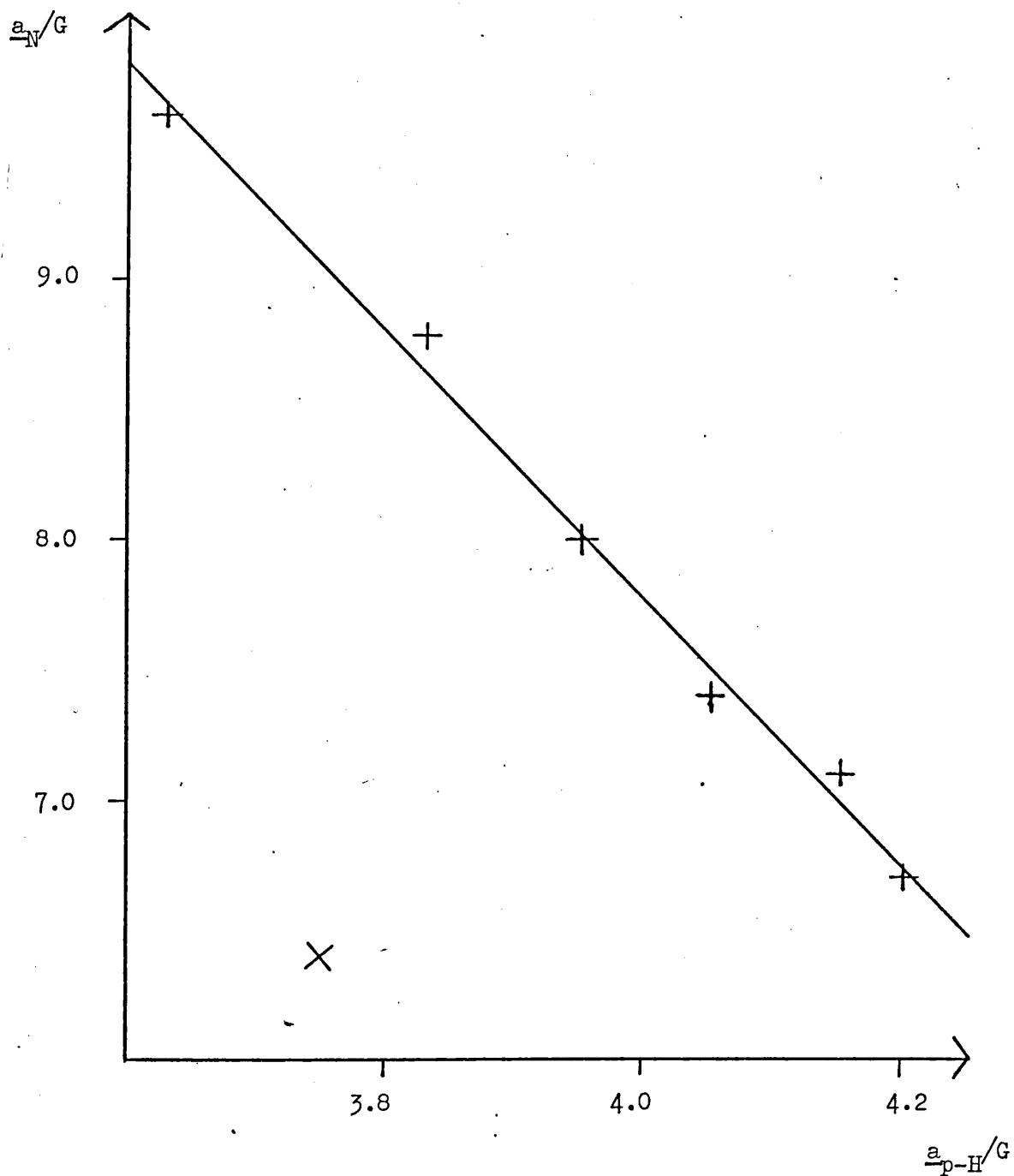

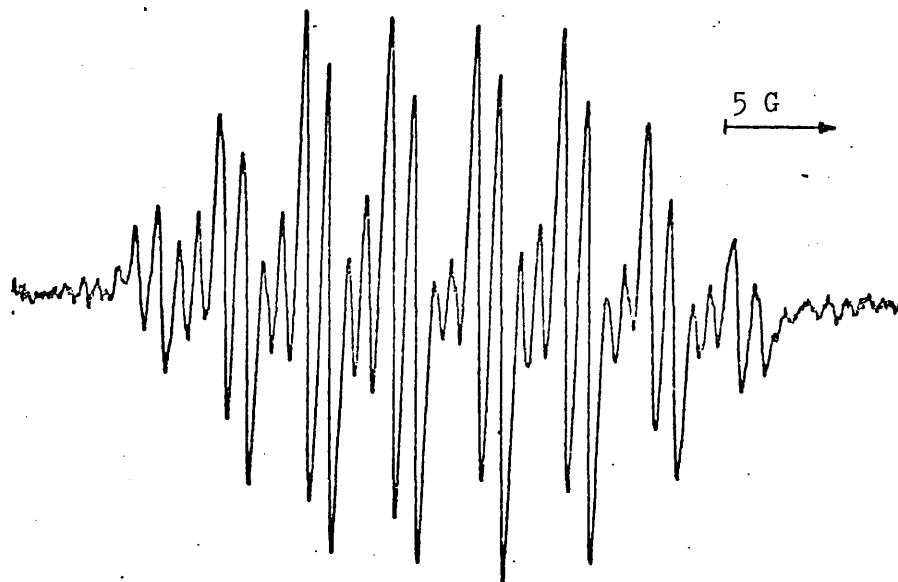

Figure 2.1 E.S.R. spectrum of the nitrosobenzene radical-anion in strongly basic DMSO solution.

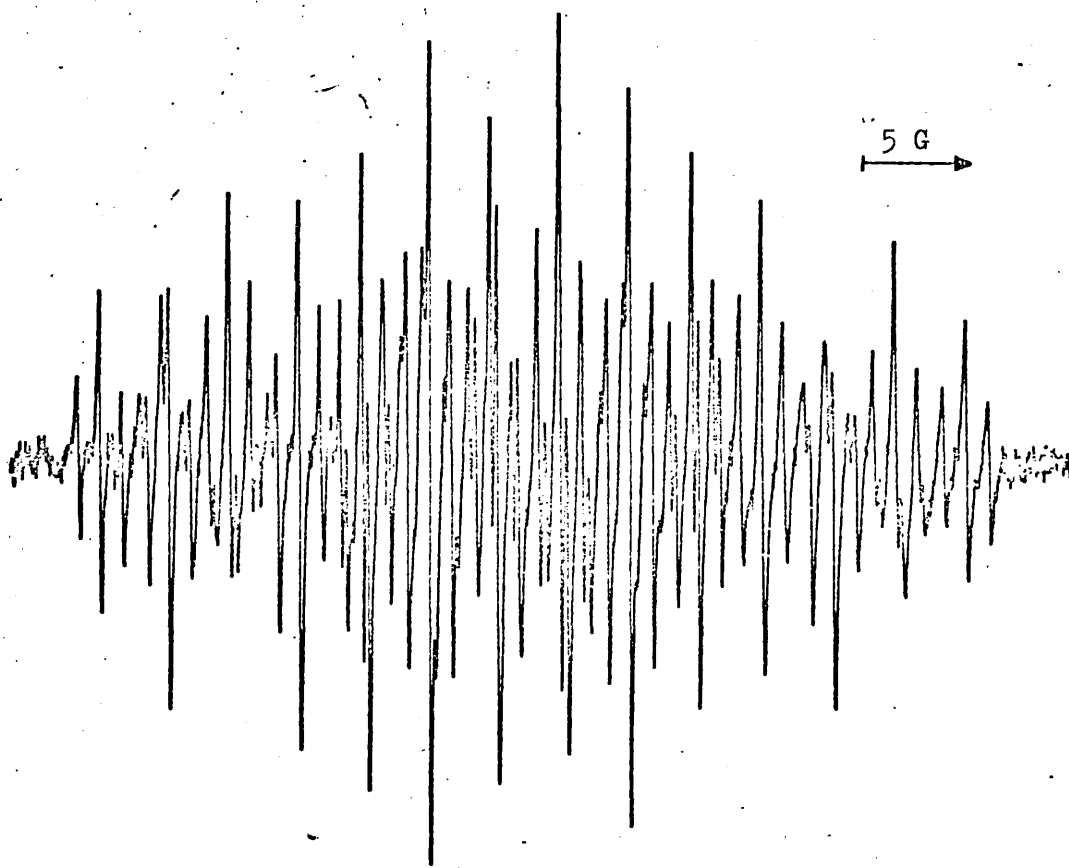

Figure 2.2 E.S.R. spectrum of phenyl nitroxide ( $\text{PhNHO}\cdot$ ) in weakly basic DMSO solution.

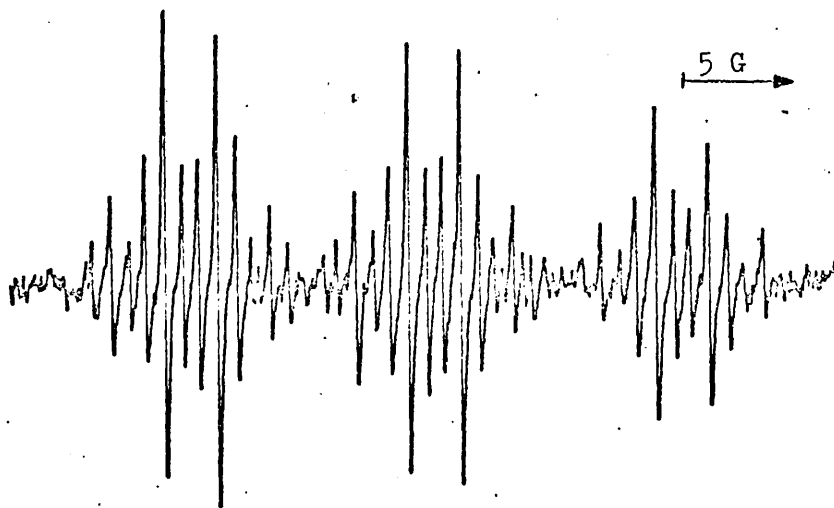

Figure 2.3 E.S.R. spectrum of  $(\text{Ph}\dot{\text{N}}\text{OH} \rightleftharpoons \text{PhNHO}\cdot)^{40}$  or  $\text{PhNOH}^{42}$  in basic DMSO solution.

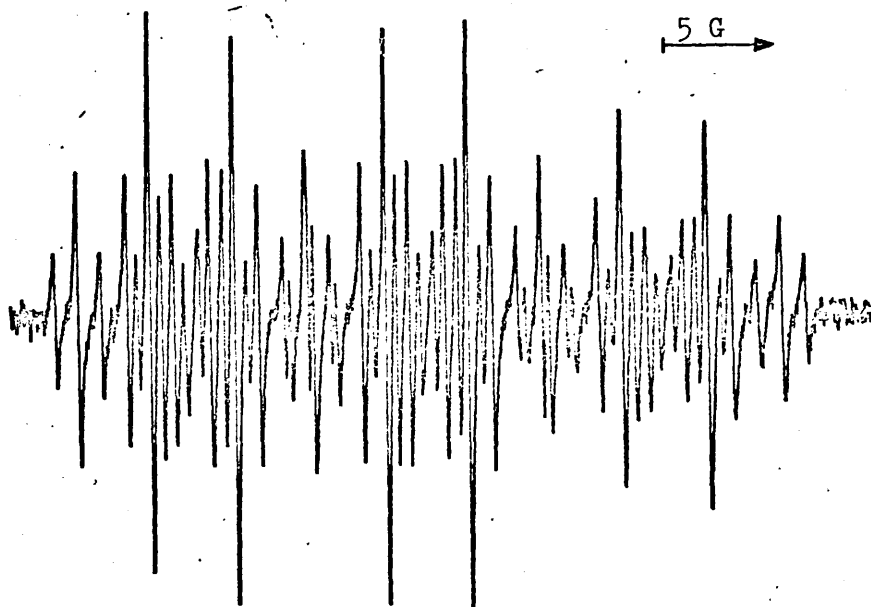

Figure 2.4 E.S.R. spectrum of the nitrobenzene radical-anion in a basic acetone/DMSO solution.

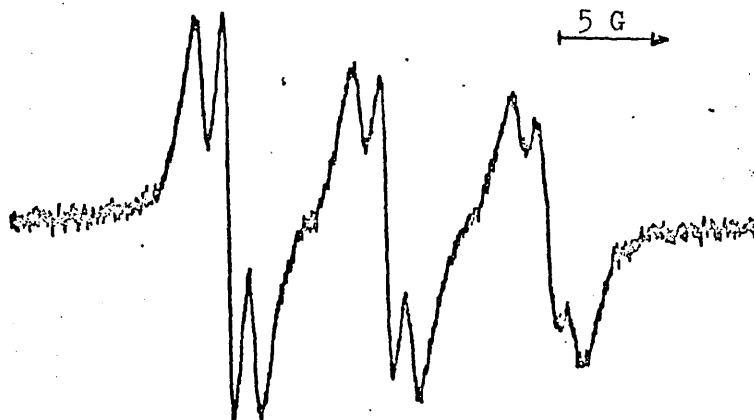

Figure 2.5 E.S.R. spectrum of the radical-anion of (VI) in alkaline aqueous DMSO.

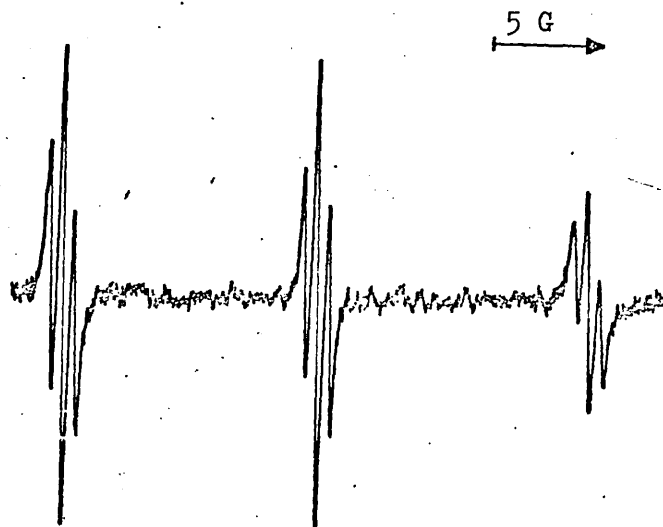

Figure 2.6 E.S.R. spectrum of the nitroxide adduct detected in basic DMSO solutions of (VI).

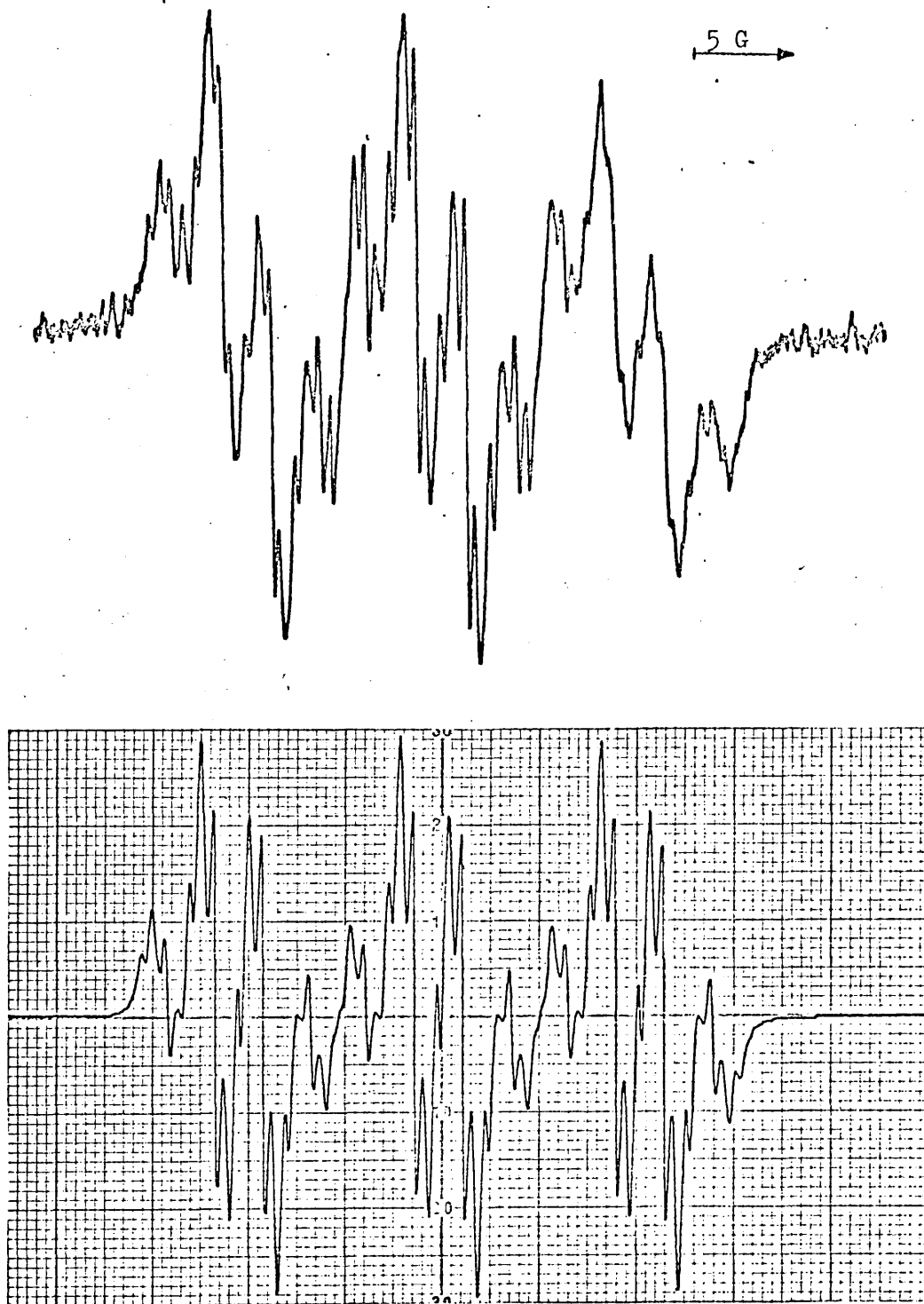

Figure 2.7 E.S.R. spectrum and simulation of the nitroxide detected from mixtures of (VI) in DMSO with sodium methoxide.



Figure 2.8

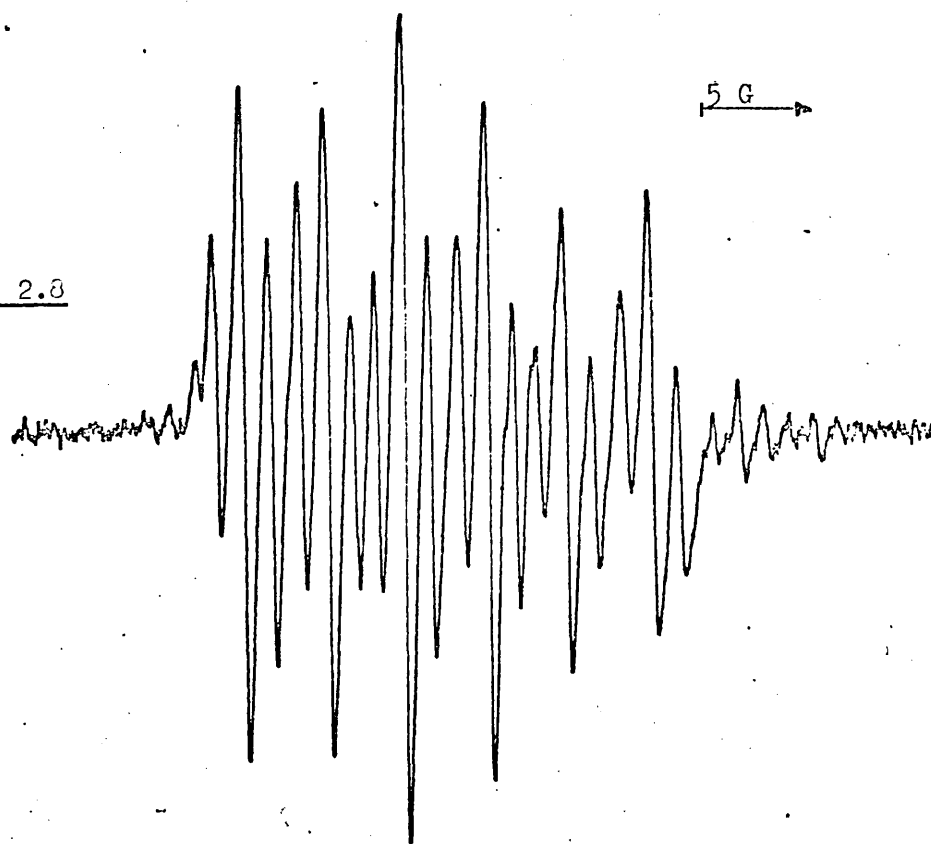

Figure 2.10

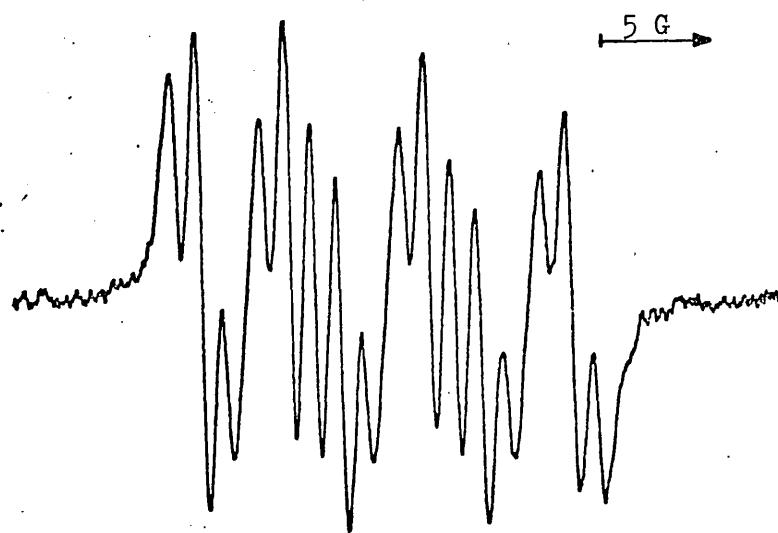

Figure 2.8 (above) ESR spectrum of a dibromonitrosobenzene radical-anion in alkaline 10% acetone-DMSO.

Figure 2.10 ESR spectrum of the radical-anion of (VII) in basic DMSO solution.

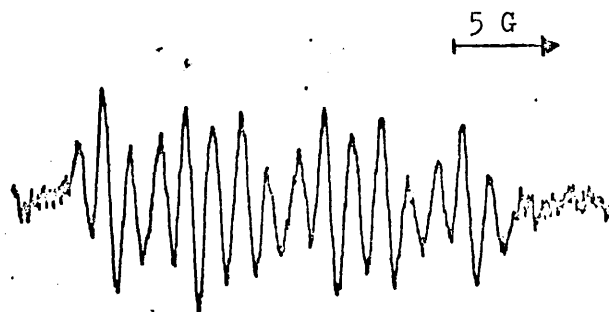

Figure 2.11 E.S.R. spectrum of a dichloronitrosobenzene radical-anion in DMSO solution after prolonged electrolytic reduction of (VIII).

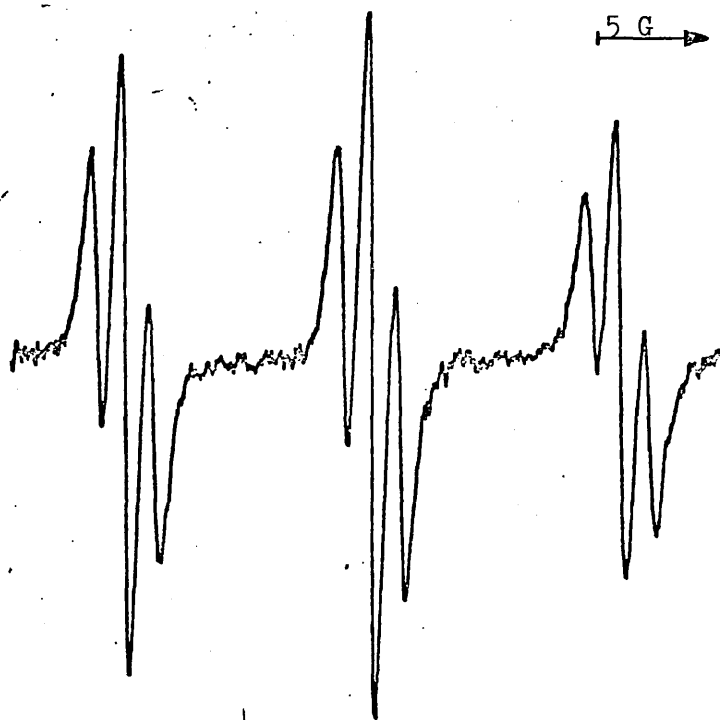

Figure 2.16 E.S.R. spectrum of the radical-anion of (X) in basic acetone/DMF/Bu<sup>t</sup>OH solution.

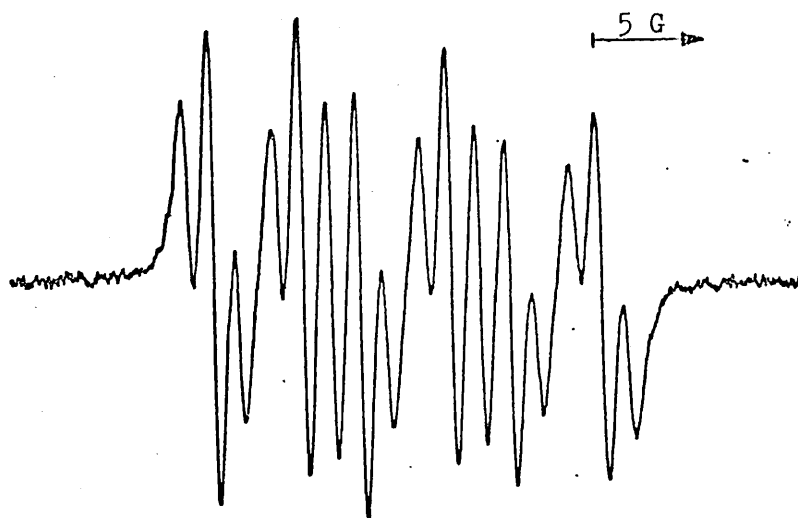

Figure 2.13 E.S.R. spectrum of the radical-anion of (IX) in alkaline aqueous DMSO.

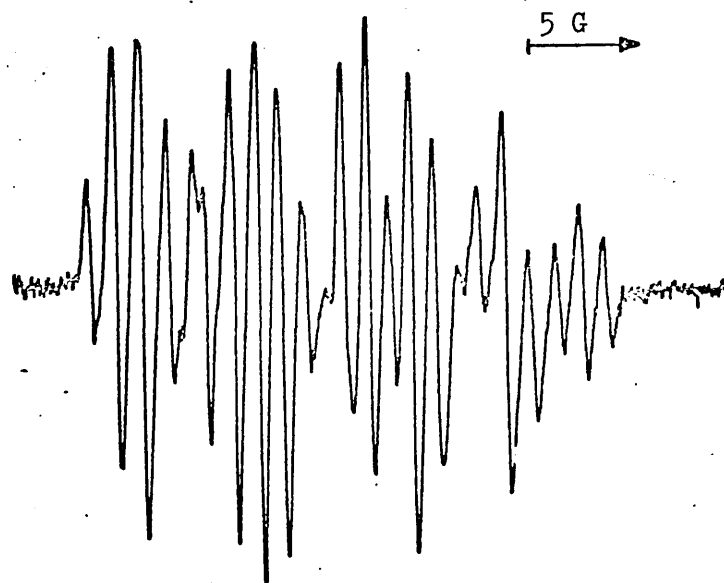

Figure 2.14 E.S.R. spectrum of a mixture of chloronitrosobenzene radical-anions in DMSO after prolonged electrolysis.

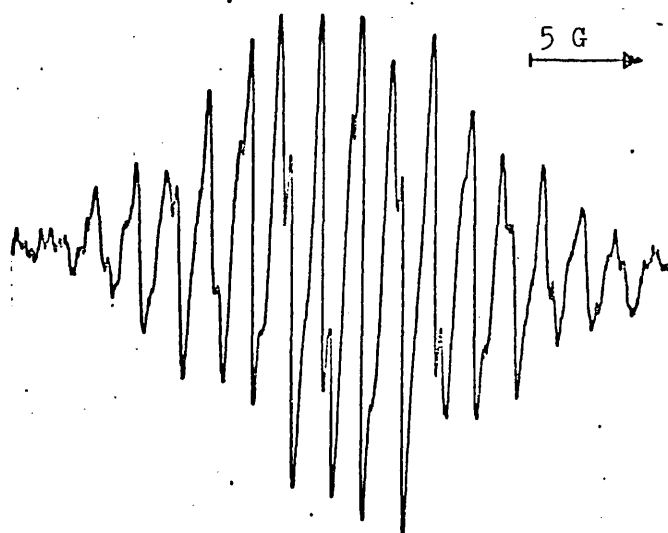
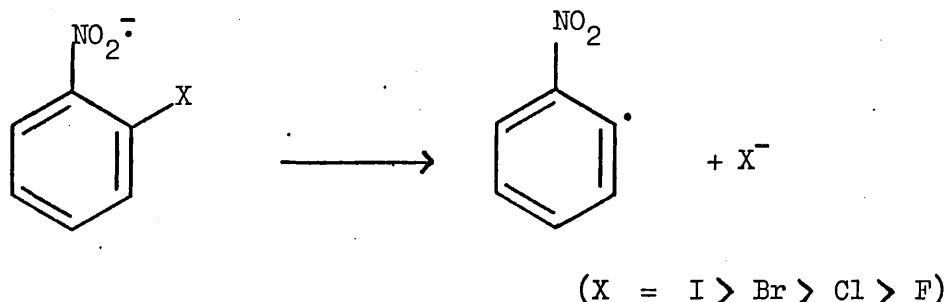

Figure 2.15 E.S.R. spectrum and simulation of a dimeric radical-anion (Section 2.2) formed from (IX) in basic DMSO solution.

2.1 F. Mechanism of loss of Halogen from the Nitrosoarenes

The 2,6- and 2,4,6-chlorine or bromine substituted nitrosobenzenes gave rise, in reducing conditions, to the radical-anions of less substituted nitrosoarenes as well as the parent radical-anions. Loss of halide ion from halogen-substituted nitroarene radical-anions has also been observed:<sup>66,67</sup>



It is most probable that a similar mechanism operates for the nitroso-compounds. The necessity of base (which is known to initiate halogen rearrangement or loss in the higher aromatic halides<sup>68</sup>) was ruled out by the results from electrochemical reductions. The possibility of the intermediacy of the corresponding nitro-radical-anion is unlikely as similar results were obtained in deoxygenated systems, where the nitro derivative would not be present. Thus the results are consistent with the following scheme:

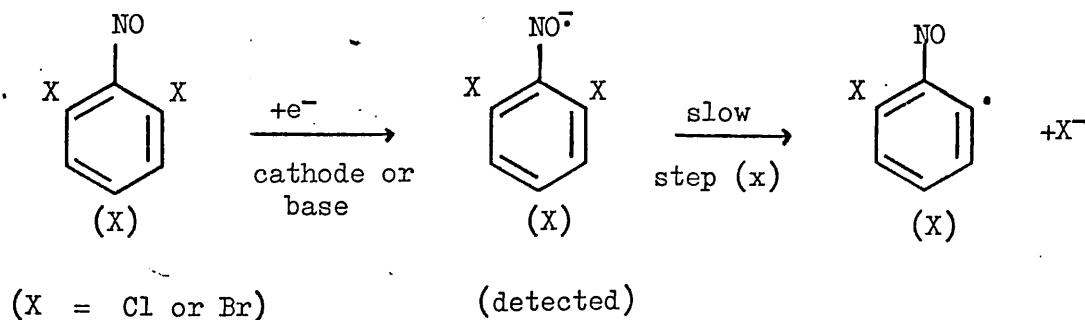

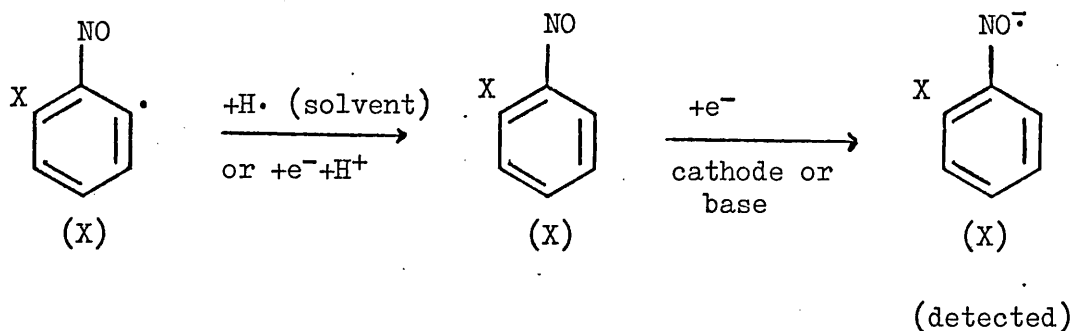

Step (x) may involve an intermediate radical-anion where the unpaired electron occupies a  $\sigma^*$  C-X orbital, as postulated in the loss of halide from 5-halogenouracil radical-anions.<sup>69</sup>

#### 2.1 G. 2,4,6-Tri-t-butylnitrosobenzene (X)

The reduction of (X) to its radical-anion was found to be more difficult than that of nitrosobenzene. Reaction of (X) in ethanol, DMF or DMSO solutions with 10% aqueous sodium hydroxide appeared to be slow and the radical-anion was not detected. Sodium methoxide or sodium hydride, added to solutions of (X), also failed to generate a detectable concentration of the radical-anion.

However, when acetone was added to the reaction mixture [e.g. (X) in DMF-t-BuOH, 6:4 (v/v)] the radical-anion was detected after 5 to 15 minutes (Figure 2.16). It was also observed that when other portions of the reaction solution were transferred to the e.s.r. cell, up to five minutes elapsed before the radical-anion signal was detected, no matter how old the reaction solution. Thus it appears that dissolved oxygen effectively prevents the build up of the radical-anion concentration and

that in the e.s.r. cell the dissolved oxygen was removed by the reaction. When the reagents were deoxygenated the radical-anion was detected as soon as the reaction mixture was transferred to the spectrometer. A similar effect was observed with 2,4,6-tri-t-butylnitrobenzene (in DMF + t-butyl alcohol + acetone + potassium t-butoxide).

The equilibrium:

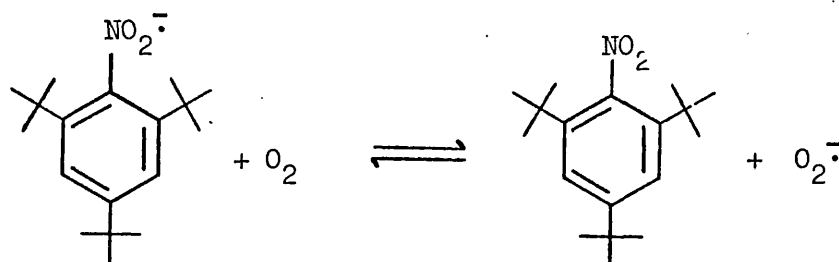

seems to be displaced too far to the right-hand-side, under the conditions used, to see the nitro-radical-anion by e.s.r., until oxygen is removed. (Half-wave polarographic reduction potentials:  $E_{1/2}$  (v. SCE), 2,4,6-tri-t-butylnitrobenzene in acetonitrile -1.5 V; nitrobenzene in acetonitrile -1.15 V;<sup>70</sup> oxygen in DMF -0.88V.<sup>71</sup>). Potassium superoxide (KO<sub>2</sub>) generates the radical-anion from more readily reducible nitroarenes.<sup>72</sup> Upon electrochemical reduction of (X) in DMF the radical-anion of (X) was detected.

#### 2.1 H. 2,6-Difluoronitrosobenzene (XI)

Solutions of (XI) reacted rapidly with bases to give several paramagnetic products, depending upon the reaction conditions. However, no spectrum that could be assigned to the radical-anion of (XI) was detected.

Instead the corresponding nitro-radical-anion was found along with dimeric species (discussed in Section 2.3). For example, when acetone was a cosolvent with DMSO or DMF, either a dimer radical or a mixture of the nitro-radical-anion and dimer were formed on addition of aqueous sodium hydroxide, (Figure 2.17). Addition of potassium t-butoxide to a solution of (XI) in DMSO generated a second dimeric radical. Similarly, electrolytic reduction gave a mixture of radicals or only one dimer (discussed in Section 2.3).

#### 2.1 J. 2,4,6-Trifluoronitrosobenzene (XII)

The radical-anion of (XII) was not detected in basic solutions of (XII) (DMSO, DMF or ethanol solvent). However, immediate colour changes on the addition of the base indicated a reaction was taking place. When potassium t-butoxide was added to a solution of (XII) in DMSO a spectrum was detected, but it was complex and of low strength and was probably from a dimeric species. Electrolytic reduction of (XII) in DMSO at a mercury cathode also led to the formation of a dimeric radical product (see Section 2.3)

#### 2.1 K. 2,3,5,6-Tetrafluoronitrosobenzene (XIII)

No spectrum which could be assigned to the radical-anion of (XIII) was detected in basic solutions of (XIII). However, colour changes did occur and in particular when aqueous sodium hydroxide was added to solutions of (XIII) in DMSO/acetone an intense blue colouration was observed along with the spectrum of a mixture of radicals at low concentration.

Reduction of (XIII) in DMF by aqueous alkaline sodium dithionite generated a complex spectrum of a dimeric species, discussed in Section



2.3. Similarly, electrolytic reduction of (XIII) in DMF or DMSO generated a series of dimeric radicals showing coupling to two nitrogen atoms (Section 2.3).

#### 2.1 L. Pentafluoronitrosobenzene (XIV)

Again the radical-anion of (XIV) was not detected in basic solutions of (XIV), and nucleophilic attack on the ring, under the conditions used, should be rapid. This was illustrated by the reaction of (XIV) in DMF or DMSO with aqueous sodium dithionite in the presence of a trace of sodium hydroxide. Only the spectrum of a tetrafluorobenzene nitrosylsulphinate radical-anion was seen (Figure 2.18) showing equivalent splitting to four fluorine atoms, [0.75 G (4F), 12.9 G (1N)] and is assigned to the *p*-hydroxy derivative by analogy with the reaction<sup>73</sup> of methoxide with (XIV) which gives 76% 4-methoxytetrafluoronitrosobenzene. A second spectrum (Figure 2.19) was detected from DMSO solutions, which exhibited coupling to all five ring fluorine atoms [12.6 G (1N), 1.25 G (1F), 1.10 G (2F) and 0.40 G (2F)]. However, this radical is not assigned to the corresponding nitrosylsulphinate radical-anion as the splitting pattern ( $|a_{\text{O}}^{\text{F}}| \sim |a_{\text{p}}^{\text{F}}| > |a_{\text{m}}^{\text{F}}|$ ) indicates a sterically unhindered nitroxide (Section 1.1), whereas the other 2,6-difluoro-substituted aryl nitrosylsulphinate derivatives show the typical hindered pattern (Table 2.3). The radical is probably derived from reaction with the DMSO solvent (Section 2.1 B).

When solutions of (XIV) in DMSO or DMF containing an excess of aqueous alkali and sodium dithionite were left to stand, spectra were observed of persistent radicals that did not exhibit coupling to a nitrogen

atom. The various radicals seen have the spectral characteristics of semiquinone radical-anions and may be formed by consecutive nucleophilic attack on (XIV) producing hydroxylated products. Hydroquinones are known to undergo autoxidation in alkaline solution in the presence of oxygen to give semiquinone radical-anions.<sup>74,75,76</sup>

For example, solutions of (XIV) in DMF or DMSO containing excess aqueous sodium dithionite and sodium hydroxide produced the radicals having the spectra shown in Figure 2.20. The splitting patterns do not allow assignment of structure. A further long-lived radical with a more complex splitting pattern was seen when a typical reaction solution was left for about ninety minutes [Figure 2.21, 2.35 (1N), 0.2 G (2), 3.55 G (1), 3.30 G (1)]. The coupling of 2.35 G from a nitrogen atom shows that the nitrogen atom of (XIV) is still bonded to the ring in this radical-anion. The spectrum is tentatively assigned to the structure (XV) by analogy with a reported<sup>77</sup> spectrum for a chlorine-substituted derivative, (XVI).

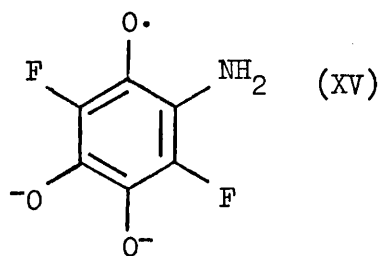
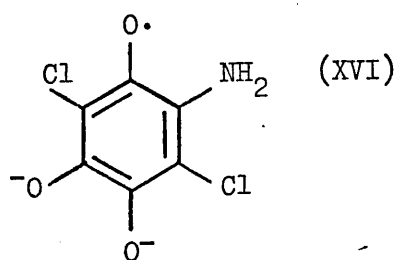

2.5 G (1N)

0.6 G (2H)

(XV) could be formed from (XIV) by nucleophilic attack of hydroxide ion at the activated ring and reduction of the nitroso group, by the

dithionite, to the amino function.

Radical (XV) could be regenerated in the reaction mixture after a day, by the addition of extra aqueous sodium hydroxide and sodium dithionite.

(XIV) was reduced electrochemically in DMSO solution at a mercury cathode. (XIV) was seen to react with tetra-n-butylammonium iodide in DMSO, to generate iodine. Nucleophilic substitution of fluorine in (XIV) by iodide has not been reported before, but the equivalent reaction for pentafluoropyridine is known.<sup>78</sup>

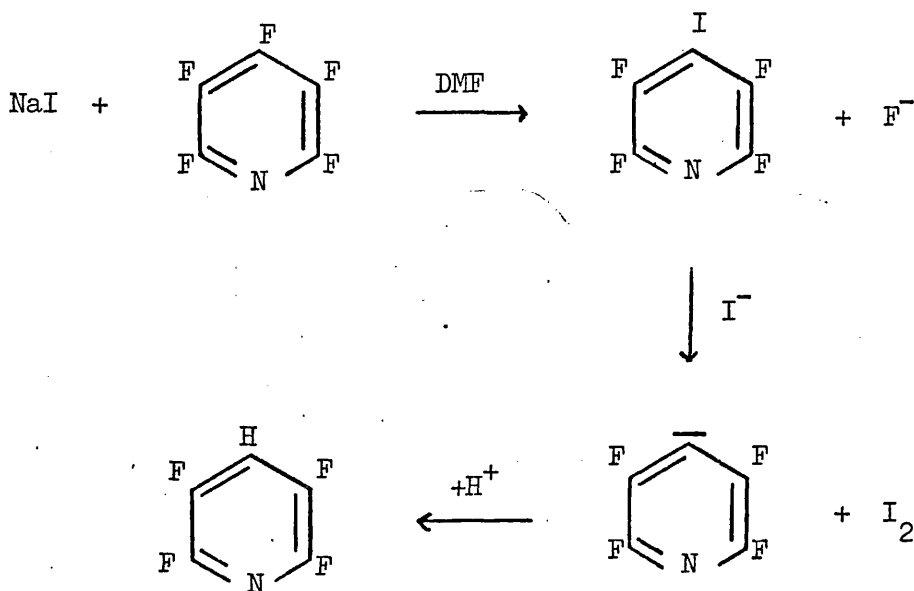

Consequently, tetra-ethylammonium perchlorate was used as the supporting electrolyte. Even so, only a tetrafluoronitrosobenzene radical-anion was detected [Figure 2.22, 8.70 G(1N), 6.15 G (2F), 1.90 G (2F)].

Table 2.1

E.S.R. Spectral Parameters of the Nitrosoarene Radical-anions

ArNO	Solvent	$a_N/G$	$a_{(m-H)}/G$ (2H)	$a_{(other)}/G$	$g$ -factor
PhNO	DMSO	7.75	1.0	3.9 (2H) 2.95 (1H)	2.0062
PhNO	EtOH	10.15	1.25	4.25 (1H) 3.9 (1H) 3.65 (1H)	
	DMSO	6.35	1.25		2.0080
	DMSO	6.6	1.2	4.2 (1H)	2.0073
	50% DMSO /EtOH	7.95	1.2		2.0071
	DMSO	7.1	1.2	4.15 (1H)	2.0072
	DMSO	9.75	1.2		
p-XC <sub>6</sub> F <sub>4</sub> NO from C <sub>6</sub> F <sub>5</sub> NO	DMSO	8.7	1.9 (2F)	6.15 (2F)	

Table 2.2

E.S.R. Spectral Parameters of the Nitroarene Radical-Anions

ArNO <sub>2</sub>	Solvent	$a_N$ /G	$a(\text{other})$ /G	$g$ -Factor
PhNO <sub>2</sub>	95% DMSO /CH <sub>3</sub> COCH <sub>3</sub>	10.9	3.9 (1H), 3.4 (2H) 1.15 (2H)	
PhNO <sub>2</sub>	CH <sub>3</sub> COCH <sub>3</sub>	13.0	3.65 (1H), 3.4 (2H) 1.1 (2H)	
PhNO <sub>2</sub> <sup>79</sup>	H <sub>2</sub> O	14.2		2.0045
	DMSO	19.1	0.9 (2H)	
	CH <sub>3</sub> COCH <sub>3</sub>	21.55	0.65 (2H)	
	50% DMSO /EtOH	18.75	0.9 (2H)	2.0053
	DMSO	19.4	0.9 (2H)	
	90% DMF/ CH <sub>3</sub> COCH <sub>3</sub>	14.2	3.8 (2), 3.0 (1) 1.05 (2H)	

Table 2.3

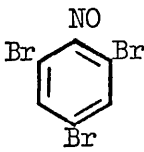
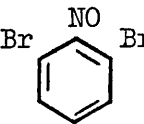
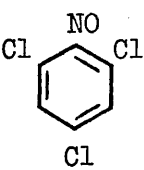
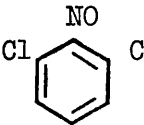
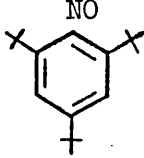
E.S.R. Spectral Parameters of the Nitrosylsulphinato Radical-Anions



Ar	Solvent	$a_N/G$	$a(\text{other})/G$	$g\text{-factor}$
Ph	aqueous EtOH	11.75	2.45 (3H) 0.85 (2H)	(2.0054) <sup>43</sup>
	DMF	12.15	0.7 (2H)	
	DMF	12.75	0.6 (2H)	2.0065
	DMF	12.8	0.6 (2H) 0.2 (1H)	2.0064
	CH <sub>3</sub> OH	12.5	0.6 (2H)	2.0060 <sup>43</sup>
	DMF	12.65	0.7 (2H) 0.2 (1H)	2.0061
	DMF	12.6	0.6 (4) 0.5 (1)	2.0061
	DMSO	12.75	0.7 (4) 0.9 (1)	
P-XC <sub>6</sub> F <sub>4</sub>	DMF	12.9	0.75 (4F)	

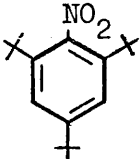
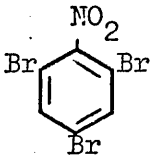
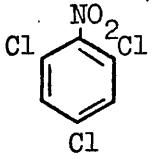
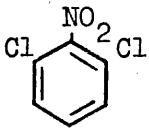
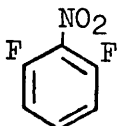
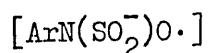
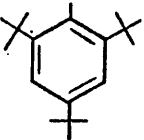
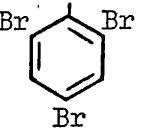
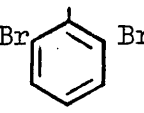
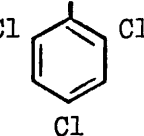
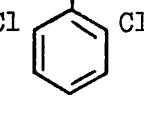
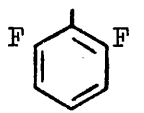
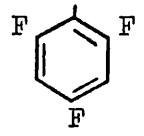
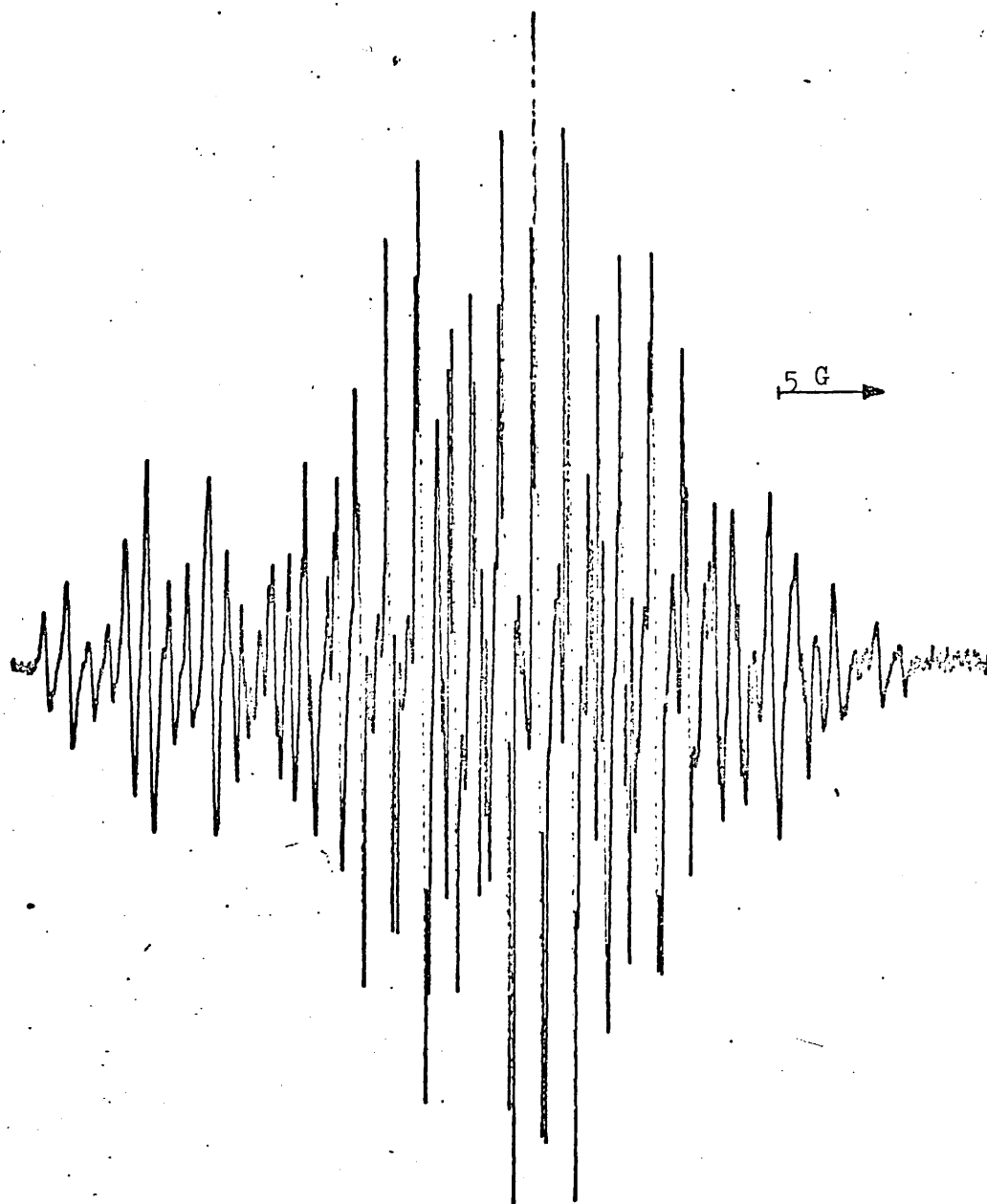

Figure 2.17 E.S.R. spectrum of a mixture of the 2,6-difluoronitrobenzene radical-anion and a dimeric radical-anion (Section 2.3) in basic DMF/acetone.

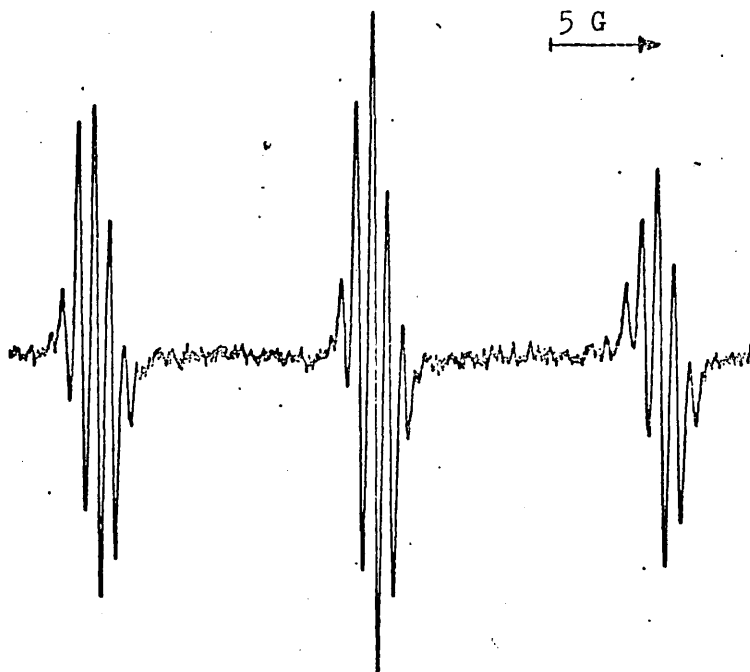

Figure 2.18 E.S.R. spectrum of a tetrafluoronitrosobenzene nitrosylsulphinate radical-anion formed from (XIV) in weakly alkaline aqueous DMSO.

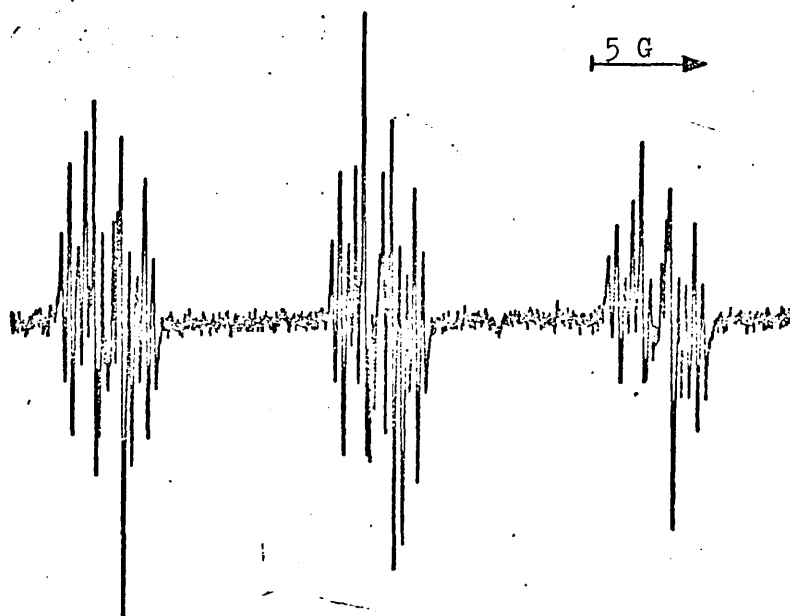

Figure 2.19 E.S.R. spectrum of the nitroxide adduct (Section 2.1B) detected from weakly alkaline aqueous DMSO solutions of (XIV).



Figure 2.20

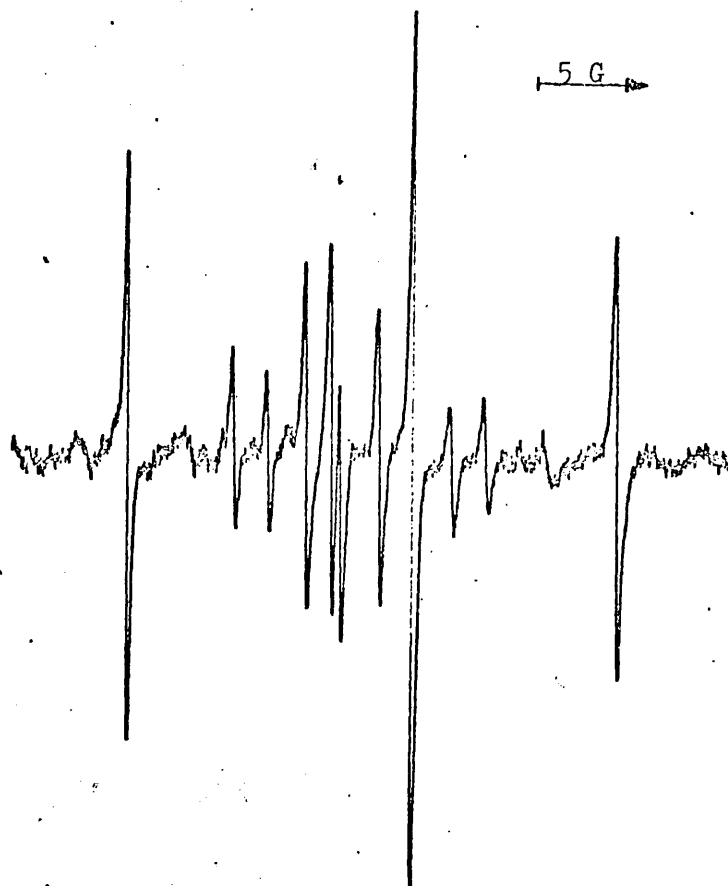

Figure 2.21

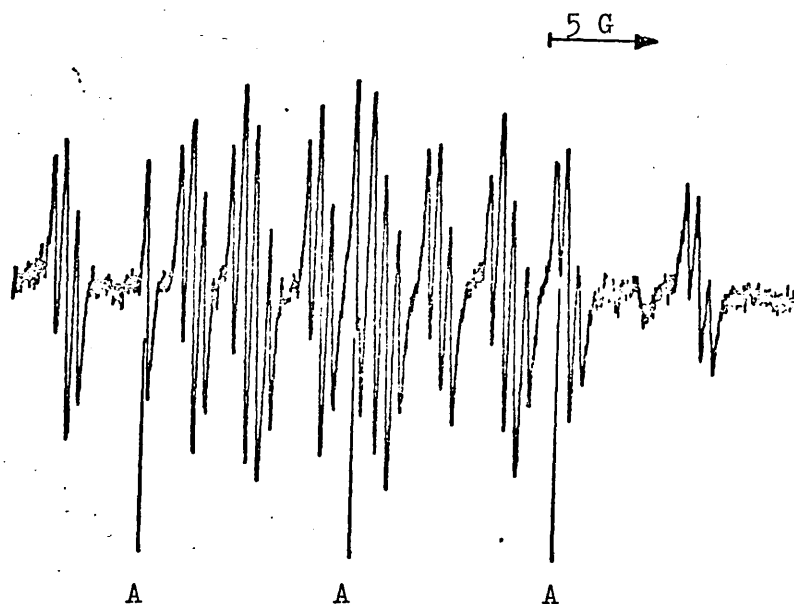

Figure 2.20 ESR spectrum of a mixture of benzoquinone radical-anions derived from (XIV) in strongly basic DMSO solution.

Figure 2.21 ESR spectrum of a nitrogen-containing benzoquinone radical-anion derived from (XIV). Lines marked A are due to a second radical.

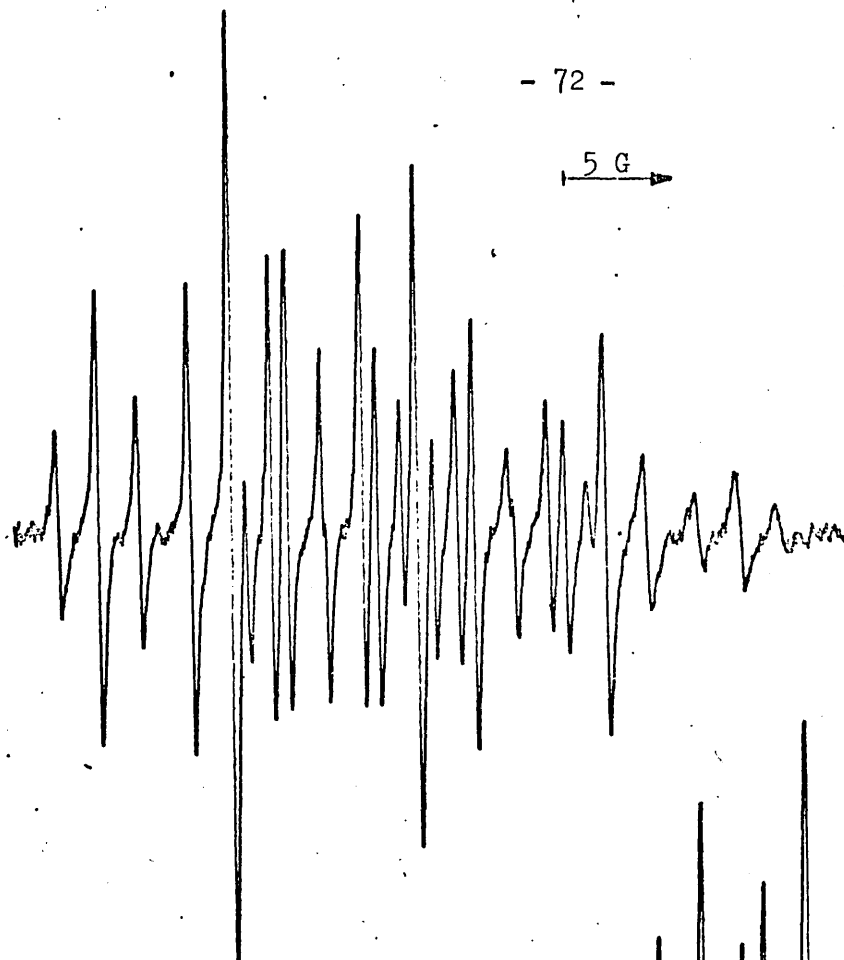

Figure 2.22 E.S.R spectrum of a tetrafluoronitrosobenzene radical-anion in DMSO solution exhibiting line-broadening (Section 2.4)

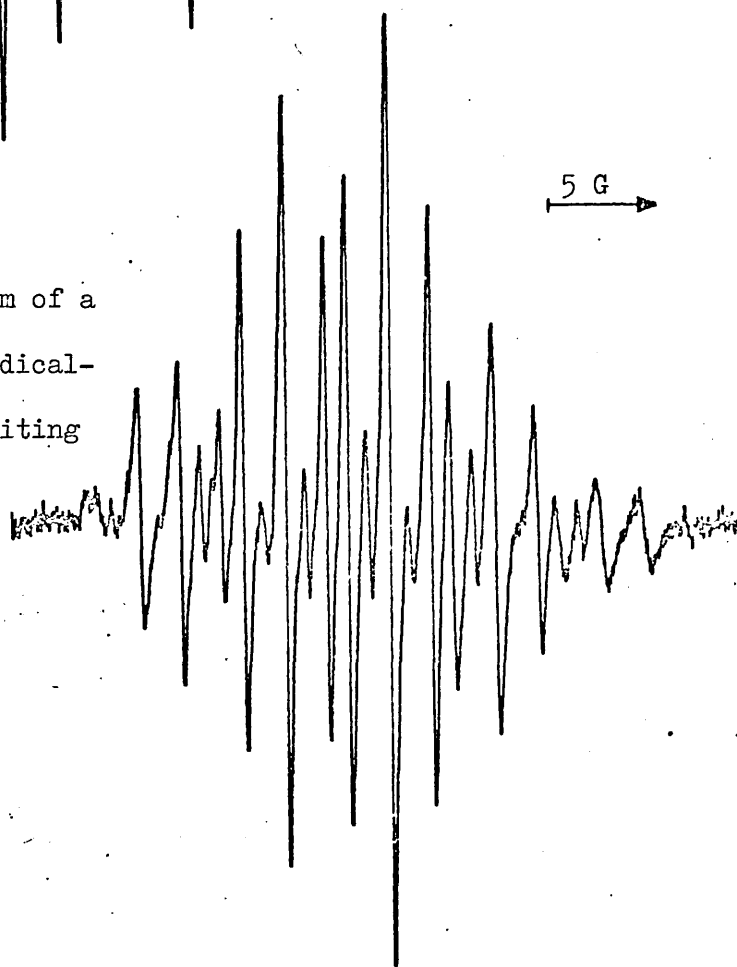
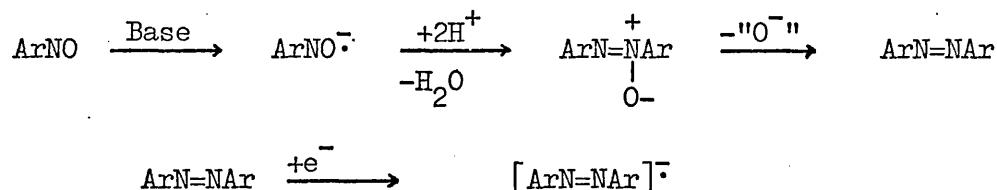

Figure 2.23 E.S.R. spectrum of a dimeric radical-anion generated from (VI) in basic DMSO solution.

Section 2.2

The Dimeric Radical-Anions Derived from Chlorine or Bromine Substituted Nitrosobenzene

The chlorine and bromine substituted nitrosobenzenes, (VI), (VIII), and (IX) generated long-lived, dimeric radical-anions (Table 2.4, for example, Figures 2.15 and 2.23) under highly basic conditions. These radical-anions are not the corresponding azo-radical-anions, possibly formed from the further reduction of the azoxy reduction product:



since the spectral parameters do not fit those observed for the radical-anions detected from the direct reduction of azobenzene derivatives (azobenzene; 2,2',4,4',6,6'-hexabromoazobenzene and 2,2',4,4'-tetrachloroazobenzene, Table 2.6, for example, Figure 2.24). The radicals may be assigned to semidiazoxide derivatives (XVII) or to species derived from halogen loss, such as (XVIII).

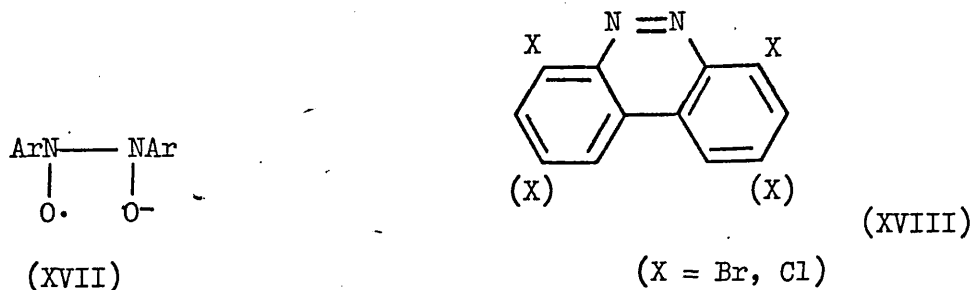

(XVII) may be formed from the corresponding dianion, which has been proposed as an intermediate of the reaction aromatic nitroso-compounds

with bases (Section 1.4). The reverse reaction, generation of the nitroso-radical-anion from azoxybenzene in strongly basic media, has been demonstrated (Section 1.4). Consequently, (XVII) may be another species present in the redox system, favoured by strongly basic conditions.

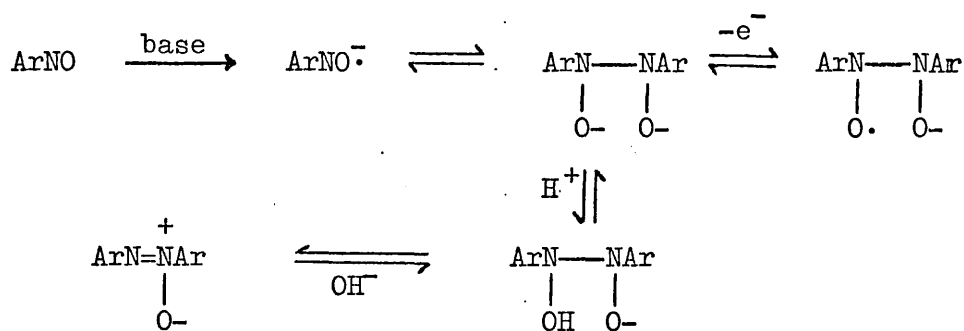

Spectra have previously been assigned to a semidiazoxide structure. Electrolytic reduction of trifluoronitrosomethane in DMF solution gave rise to signals assigned to the nitro-radical-anion and the corresponding semidiazoxide (XIX), [7.4 G (2N), 17.8 (6F)].<sup>80</sup>

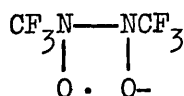

(XIX)

However, the spectrum assigned to (XIX) was later shown to be that of the corresponding azo-radical-anion.<sup>81</sup> Spectra (showing two non-equivalent nitrogen splittings) obtained from the reduction of nitroso-compounds at low temperatures, have also been assigned to a semidiazoxide structure.<sup>82</sup> For example,<sup>82</sup>

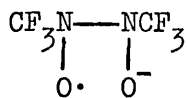

10.8 G (1N, 3F)

2.8 G (1N, 3F)

at -110 °C

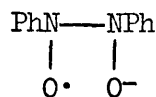

10.2 G (1N)

2.6 G (1N)

2.4 G (2H)

0.85 G (2H)

at -25 °C

The spectrum derived from trifluoronitrosomethane with the above splitting constants has been detected by others,<sup>80</sup> but assignment was not attempted.

The possibility that the radical-anions are species derived by halogen loss [such as (XVIII)] is remote since the meta-proton splittings are equivalent (unlike the 2 and 4 positions of 9,10-diazaphenanthrene radical-anion, Table 2.6).

Alternatively, the radicals may be derived from reactions involving nucleophilic attack on the halogen substituents, as outlined by Bunnett,<sup>68</sup> which would be favoured under the conditions used. However, the splitting constants observed do not suggest a rearrangement.

Table 2.4

E.S.R. Spectral Parameters of the Dimeric Radical-Anions detected from Chlorine- or Bromine-Substituted Nitrosobenzene.

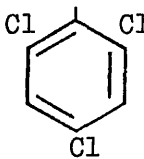
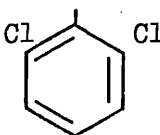
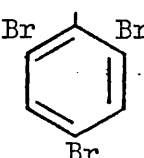
Ar	Solvent	Hyperfine splitting/G		g-factor
		$a_N(2N)$	$a(\text{other})$	
	DMSO	4.8	1.9 (4H)	2.0036
	DMSO	4.8	1.9 (4H) 3.4 (2H)	2.0035
	DMSO	4.8	1.9 (4H)	2.0044

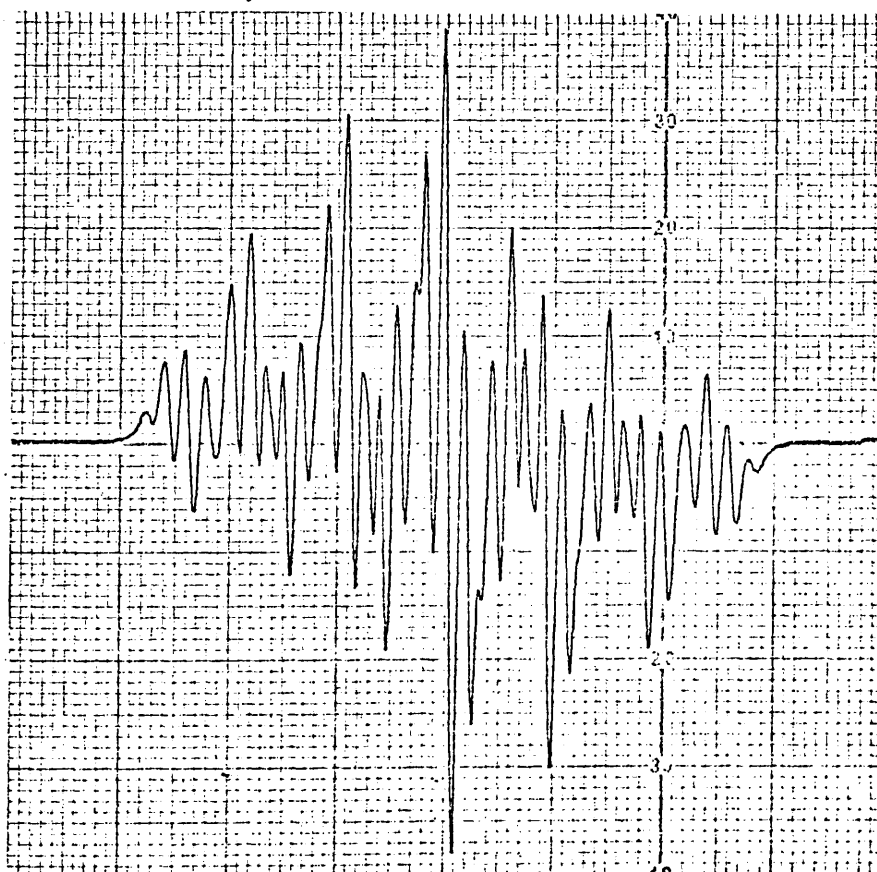
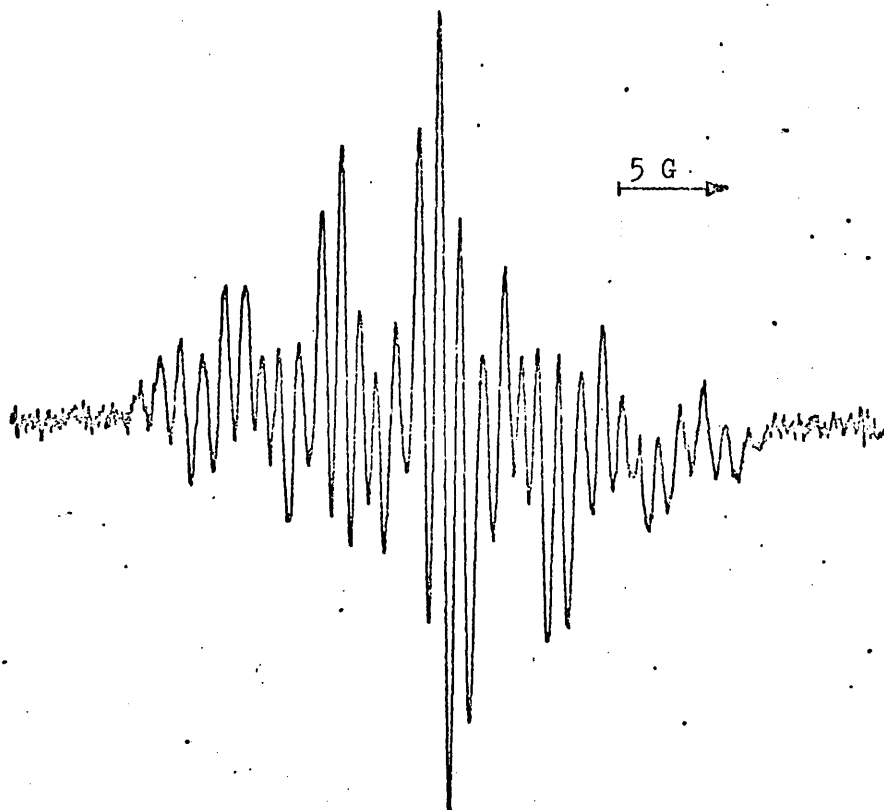

Figure 2.24 ESR spectrum and simulation of the radical-anion of 2,2',4,4'-tetrachloroazobenzene in basic acetone/DMSO solution.

### Section 2.3

#### The Dimeric Radical-Anions Derived from Fluorine Substituted Nitrosobenzene

The fluorine substituted nitrosobenzenes (XI), (XII) and (XIII) when reduced in basic conditions or by electrolysis generated dimeric radical-anions. These dimeric species are assigned to the corresponding azoxy- and azo-radical-anions and their further reaction products. The spectra obtained were complex, exhibiting coupling to two nitrogen nuclei and up to ten hydrogen or fluorine nuclei. The spectra also showed the asymmetric line-broadening effect (Section 2.4) and consequently unambiguous assignment of splittings was not always possible.

#### 2.3 A. 2,3,5,6-Tetrafluoronitrosobenzene (XIII)

Electrolytic reduction of (XIII) in DMF solution gave rise initially to a spectrum (Figure 2.25, Radical A) having no central line, but coupling to more than one benzene ring, suggesting an unsymmetrical dimeric structure perhaps with non-equivalent nitrogen atoms. The spectrum was assigned to the azoxy-radical-anion (XX) with the possible splitting constants given in Table 2.5.

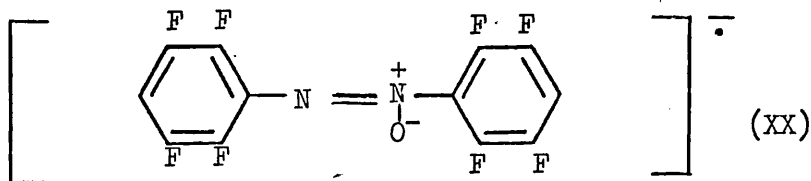

Shortly after observation of the azoxy-radical-anion a second radical (Radical B) was detected, which predominated after a period of continuous electrolysis (Figure 2.26). The spectrum showed coupling



to two equivalent nitrogen atoms and ten half-spin nuclei. [The spectrum was simulated (Figure 2.26) using the splitting constants 5.07 G (2N), 3.4 G (4), 2.1 (4) and 2.98 G (2) with peak-to-peak linewidth of 0.2 G. These values agree reasonably well with the part of the spectrum having the narrowest linewidth. The ends of the spectrum and the simulation are not in good agreement as the radical was never observed in the absence of other weak signals.] In DMF solution no further radicals were detected. Electrolytic reduction of (XIII) in DMSO solution initially produced Radical B which was later replaced by a stronger signal (Figure 2.27, Radical C) showing coupling to two equivalent nitrogen nuclei and eight half-spin nuclei.

Electrolytic reduction of an authentic sample of 2,2',3,3',5,5',6,6'-hexafluoroazobenzene in DMSO solution gave initially a spectrum identical to that of Radical B followed by that of Radical C. Consequently Radical B was assigned to the azo-radical-anion and Radical C either to a secondary product probably formed through loss of fluorine, or to a cyclic product such as (XXI) or (XXII).

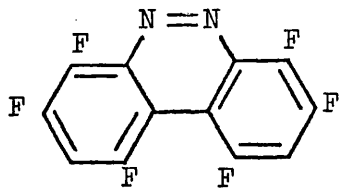

(XXI)

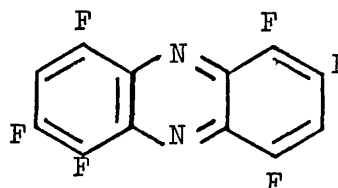

(XXII)

Electrolytic reduction of an authentic sample of (XXII) gave the radical-anion exhibiting coupling to two equivalent nitrogen nuclei and eight half-spin nuclei (Figure 2.28), the couplings did not correspond with

any of those obtained from other dimers, but the  $g$ -factor was the same as that of Radical C and of other dimers observed from (XI) and (XII). Reduction of (XIII) by chemical means (sodium dithionite and sodium hydroxide in aqueous DMF) also produced dimeric species. However, complete analysis was not attempted as the radicals were in low concentration and the wings of the spectra were not detected.

### 2.3 B. 2,6-Difluoronitrosobenzene (XI)

Reduction of (XI) in DMSO with potassium *t*-butoxide (conditions known to generate the azobenzene radical-anion from azobenzene<sup>83</sup>) generated a dimeric radical of similar  $g$ -factor to Radical B above, and exhibiting coupling to two equivalent nitrogen atoms and ten half-spin nuclei. (Figure 2.29). The radical was also observed from the action of sodium methoxide on (XI) in DMSO (but was later replaced by a second dimer, Radical D) and is assigned to the azo-radical-anion, (XXIII)

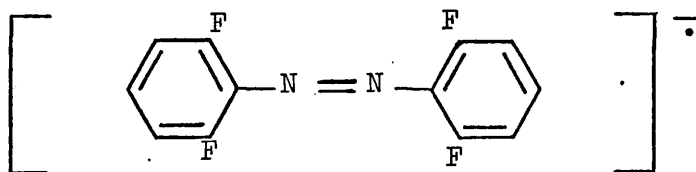

(XXIII)

Radical D, observed after (XXIII) when sodium methoxide was added to a solution of (XI) in DMSO, was also detected when aqueous sodium hydroxide was added to (XI) in DMSO/acetone mixtures, (Figure 2.30). The radical shows coupling to two equivalent nitrogen nuclei and eight

half-spin nuclei. The radical was also detected, together with the corresponding nitro-radical-anion (Figure 2.17), from the electrolytic reduction of (XI), after approximately 10 to 15 minutes of current flow. The above results indicate that the radical is a secondary product, and it has the same  $g$ -factor as Radical C, also a secondary product.

### 2.3 C. 2,4,6-Trifluoronitrosobenzene (XII)

From (XII) only one dimeric radical-anion was detected, having a  $g$ -factor similar to the secondary Radicals, C and D, and was observed from electrolytic reduction of (XII) after approximately 15 minutes current flow (Figure 2.31).

The results obtained in this section may be summarised by the following scheme:

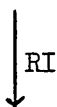
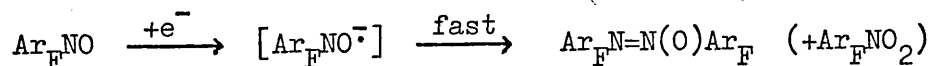

Trapped as nitroxide  
(Chapter 3)

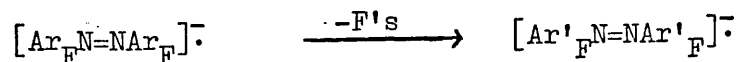
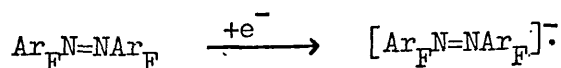
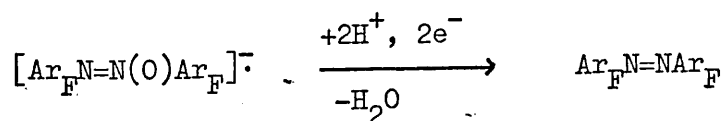
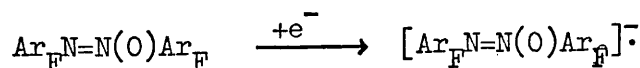

and possibly

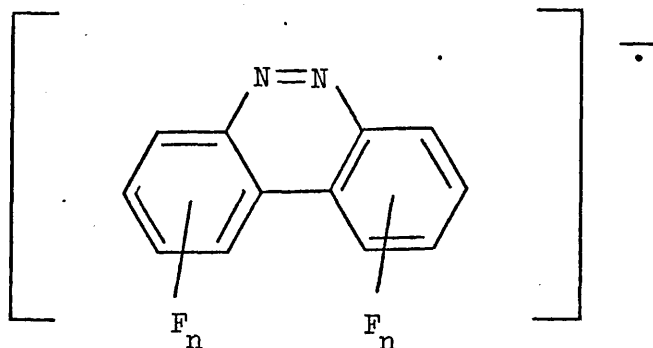

The results show that, in solvents such as DMF and DMSO, the nitroso-radical-anion side of the equilibrium with its dimer is not favoured and the reaction proceeds readily the azoxy stage and further. These results contrast with those obtained from nitrosobenzene, where the nitroso-radical-anion is favoured (Sections 1.4 and 2.1A).

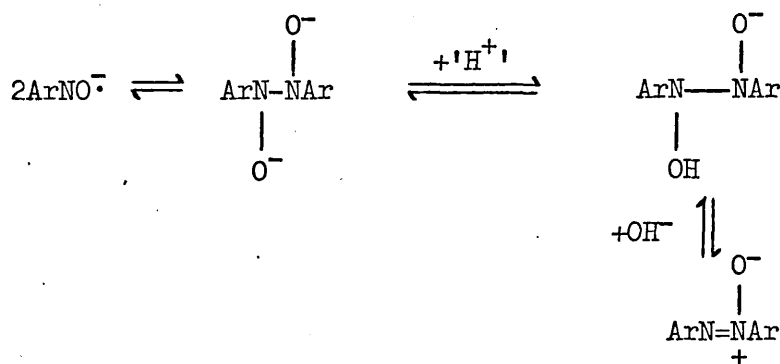

Trifluoronitrosomethane behaves similarly to fluorine substituted nitrosoarenes as only the azo- and nitro- radical-anions were observed<sup>80,81</sup> or the dimer may predominate.<sup>82</sup>

Table 2.5

E.S.R. Spectral Parameters of the Dimeric Radical-Anions detected from  
Fluorine Substituted Nitrosobenzene

ArNO	Assignment	Hyperfine Splittings/G		g-factor
		$\underline{a}_N(2N)$	$\underline{a}(\text{other})$	
	azo-radical-anion	6.10	3.20 (4) 1.45 (2) 1.15 (4)	2.0039
	secondary (D)	5.40	3.1 (2) 1.55 (4) 1.35 (2)	2.0033
	azoxy-radical-anion (A)	9.6 (1N) 4.8 (1N)	3.5 (1) 4.8 (3) 1.25 (4)	
	azo-radical-anion (B)	5.07	3.40 (4) 2.98 (2) 2.1 (4)	2.0038
	secondary (C)	4.90	3.90 (2) 2.55 (2) 2.35 (4)	2.0033
	Secondary	5.2	3.30 (2) 2.20 (2) 1.40 (4)	2.0034

Table 2.6

E.S.R. Spectral Parameters of Radical-Anions relevant to Sections 2.2 and 2.3

Structure	Hyperfine Splittings/G		Reference
	$a_N(2N)$	$a(\text{other})$	
PhN=NPh <sup>†</sup>	4.84	2.15(2,2') 2.94(6,6') 3.20(4,4') 0.64(3,3') 0.91(5,5')	84
PhN=NPh	4.84	2.03(2,2') 2.81(6,6') 2.81(4,4') 0.78(3,3',5,5')	37
	5.27	3.58(2H) 2.83(2H) 0.77(2H) 0.28(2H)	85
	4.50	0.90(4H)	
	4.50	3.05(2H) 0.90(4H)	
	5.40	2.40(2) 1.90(4) 1.55(2)	
CF <sub>3</sub> N=NCF <sub>3</sub>	7.4	17.8(6F)	80,81

<sup>†</sup>  $g = 2.0036$

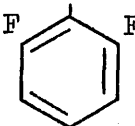
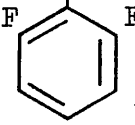
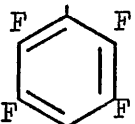
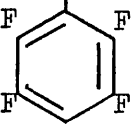
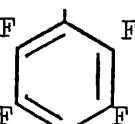
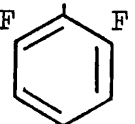
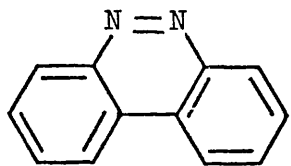
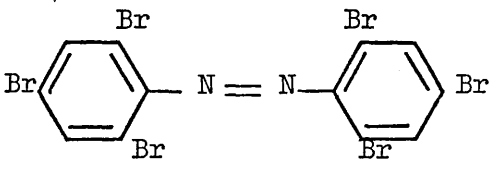
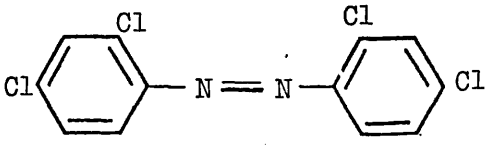
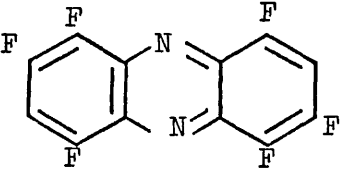
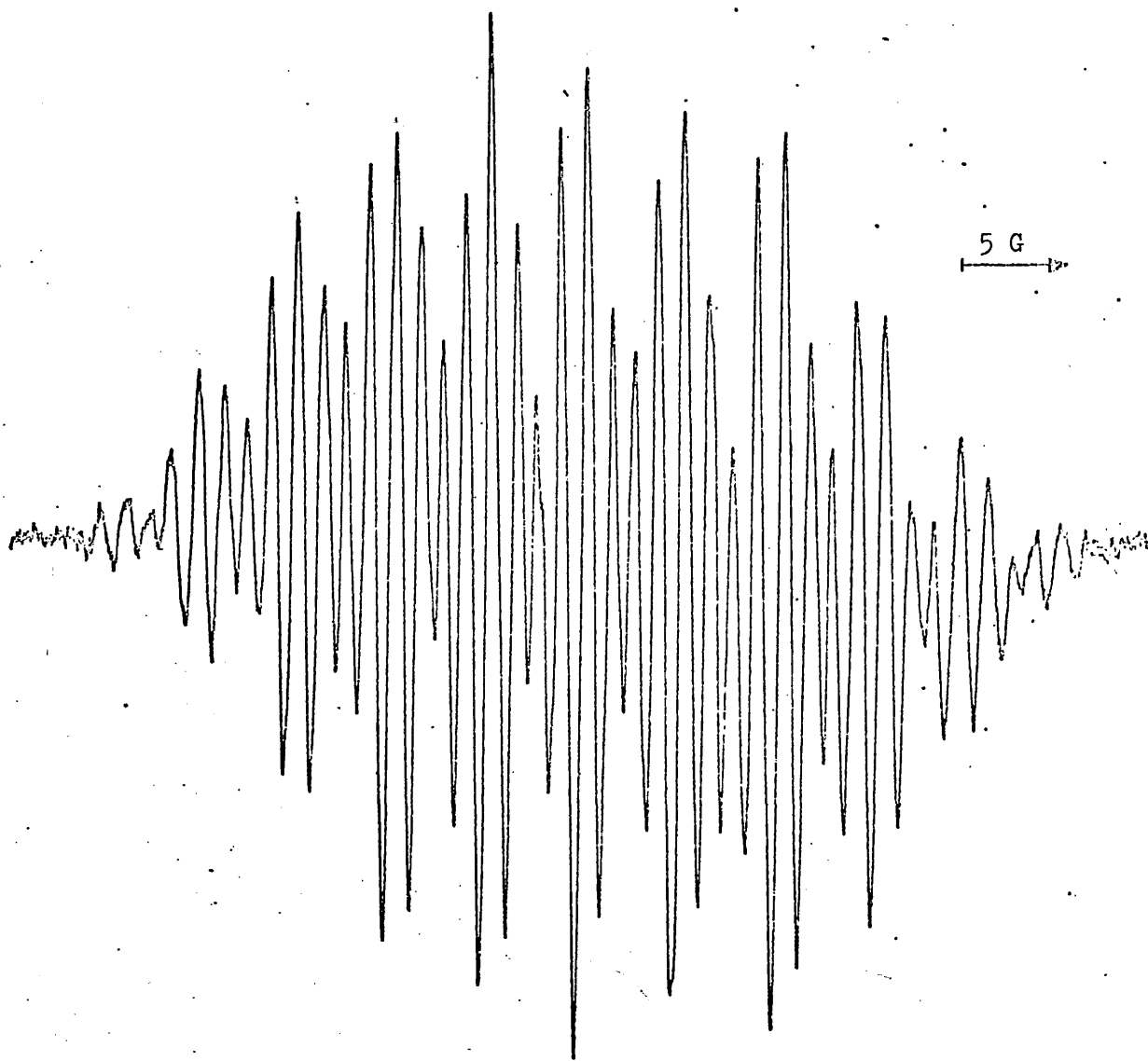

Figure 2.25 ESR spectrum of Radical A, derived from electrolytic reduction of (XIII) in DMF solution.

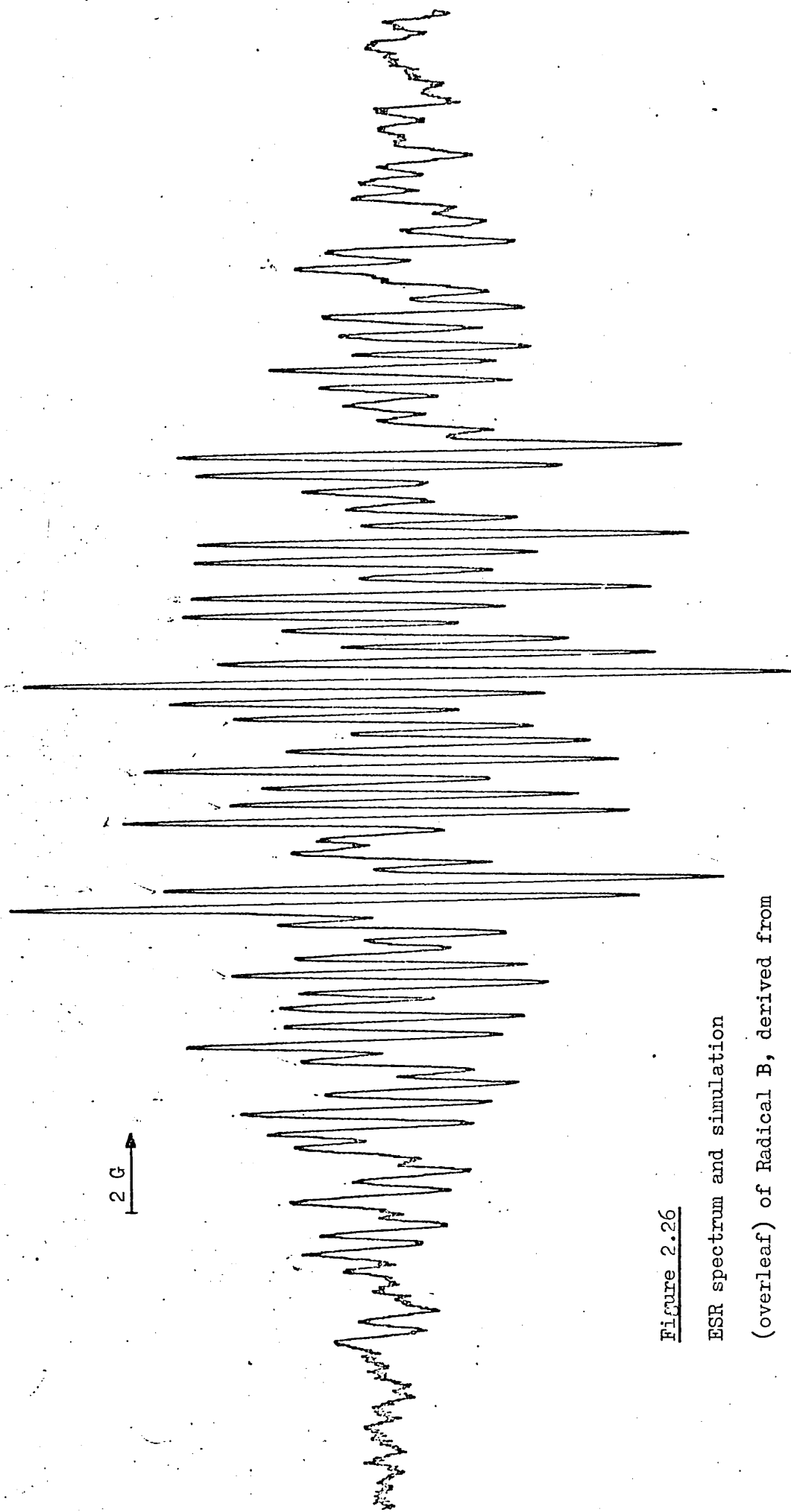

Figure 2.26

ESR spectrum and simulation

(overleaf) of Radical B, derived from

electrolytic reduction of (XIII) in DMF solution.



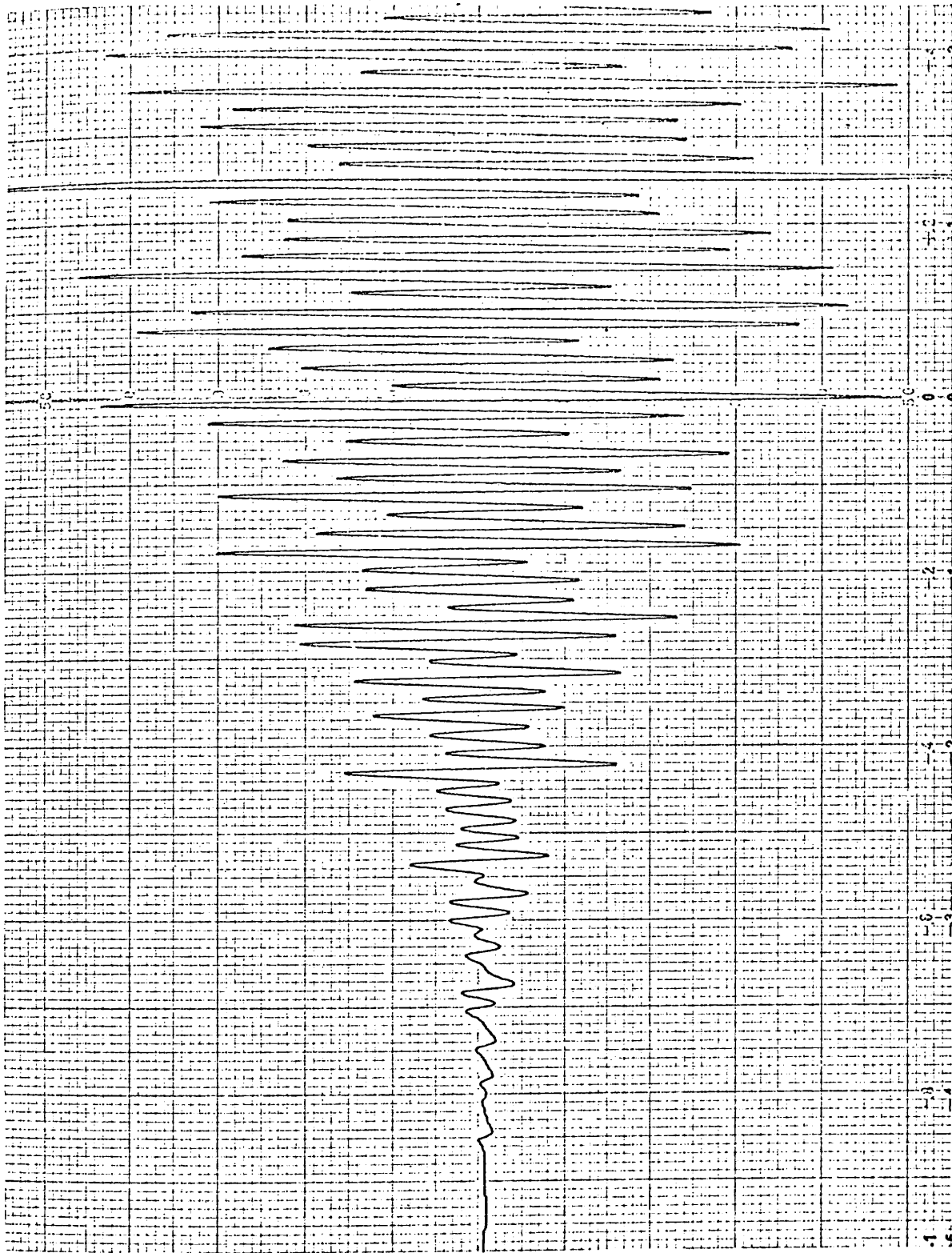

centre

Figure 2.26

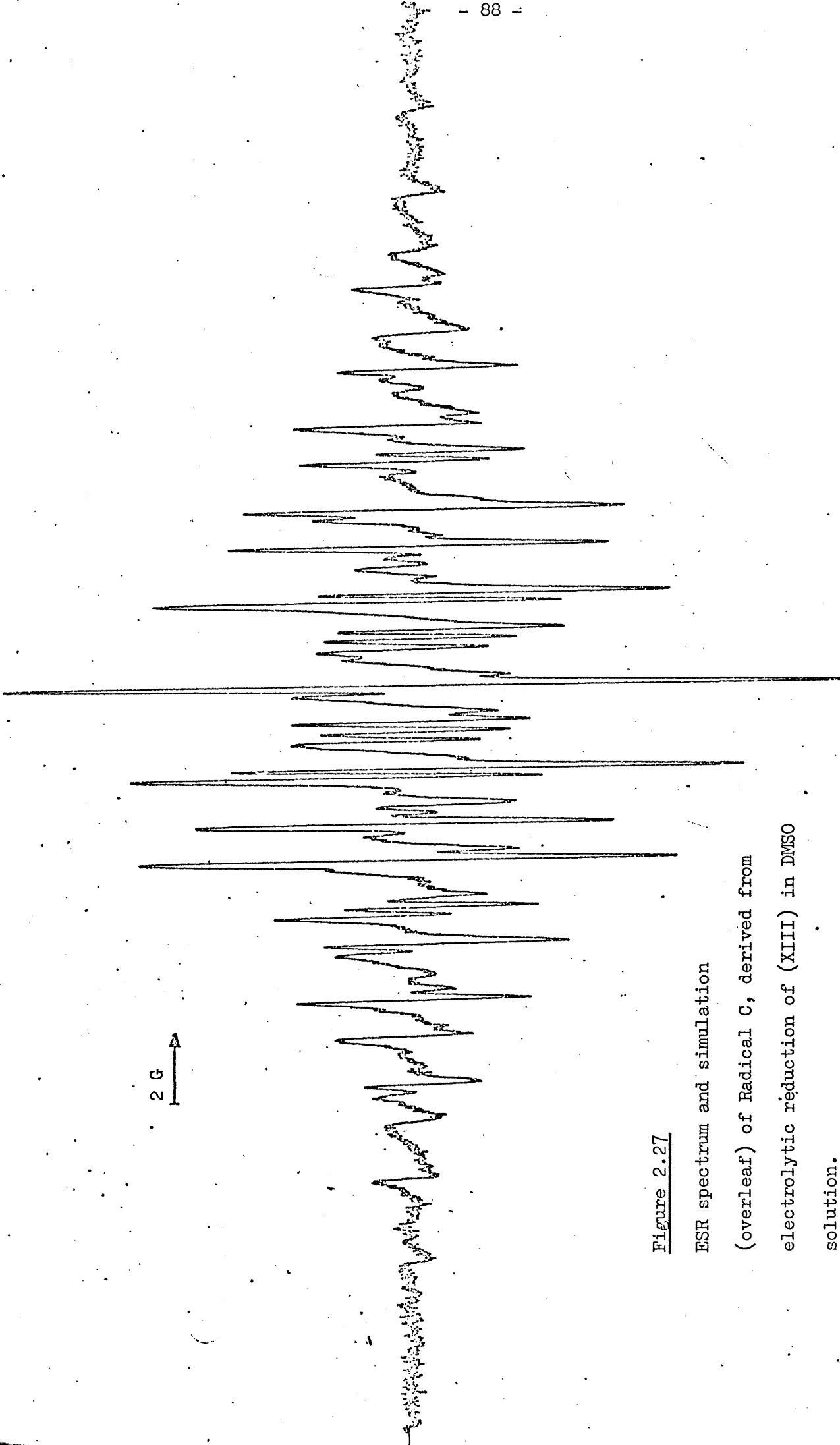
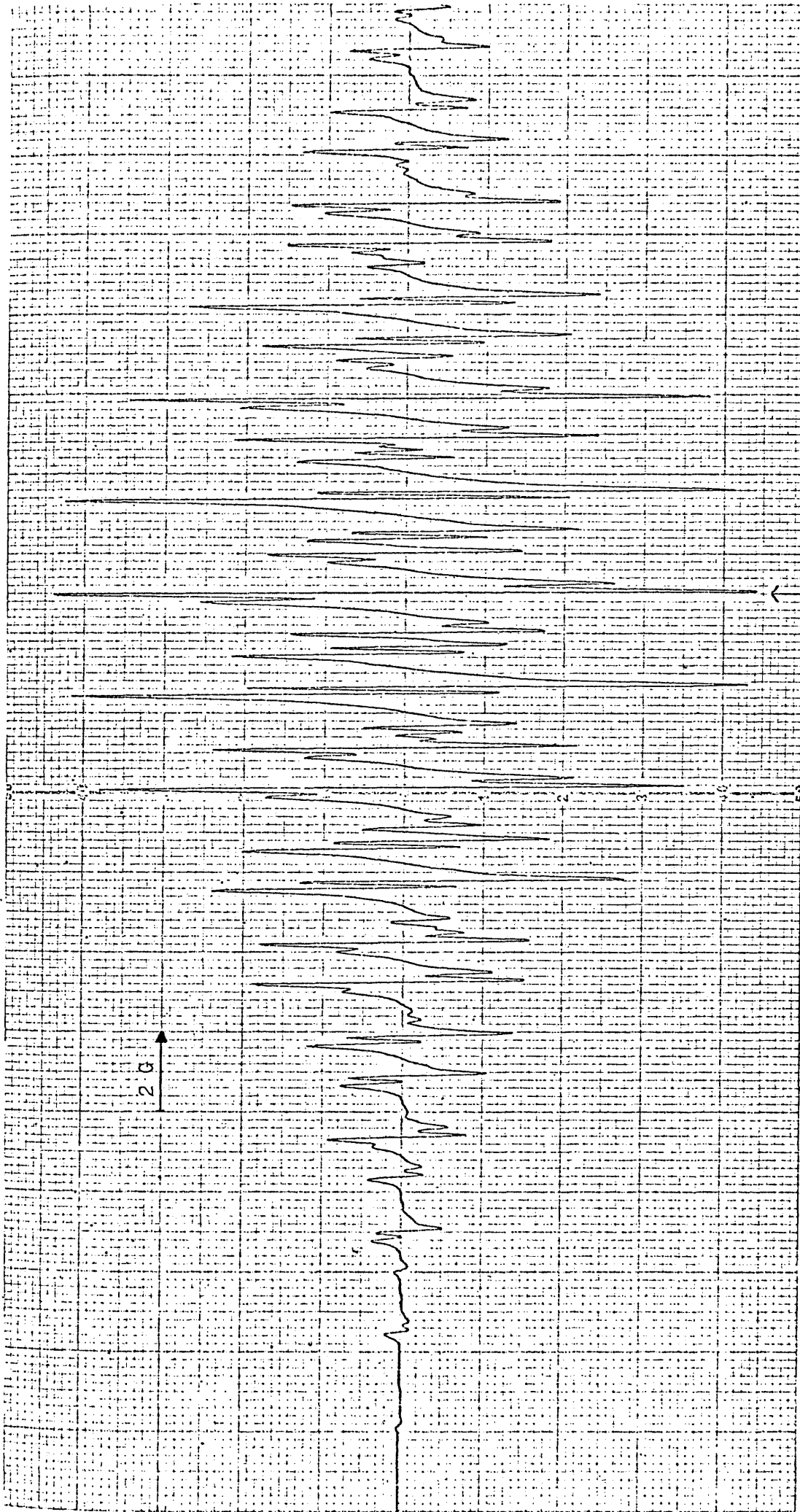

Figure 2.27

ESR spectrum and simulation  
(overleaf) of Radical C, derived from  
electrolytic reduction of (XIII) in DMSO  
solution.



centre

Figure 2.27

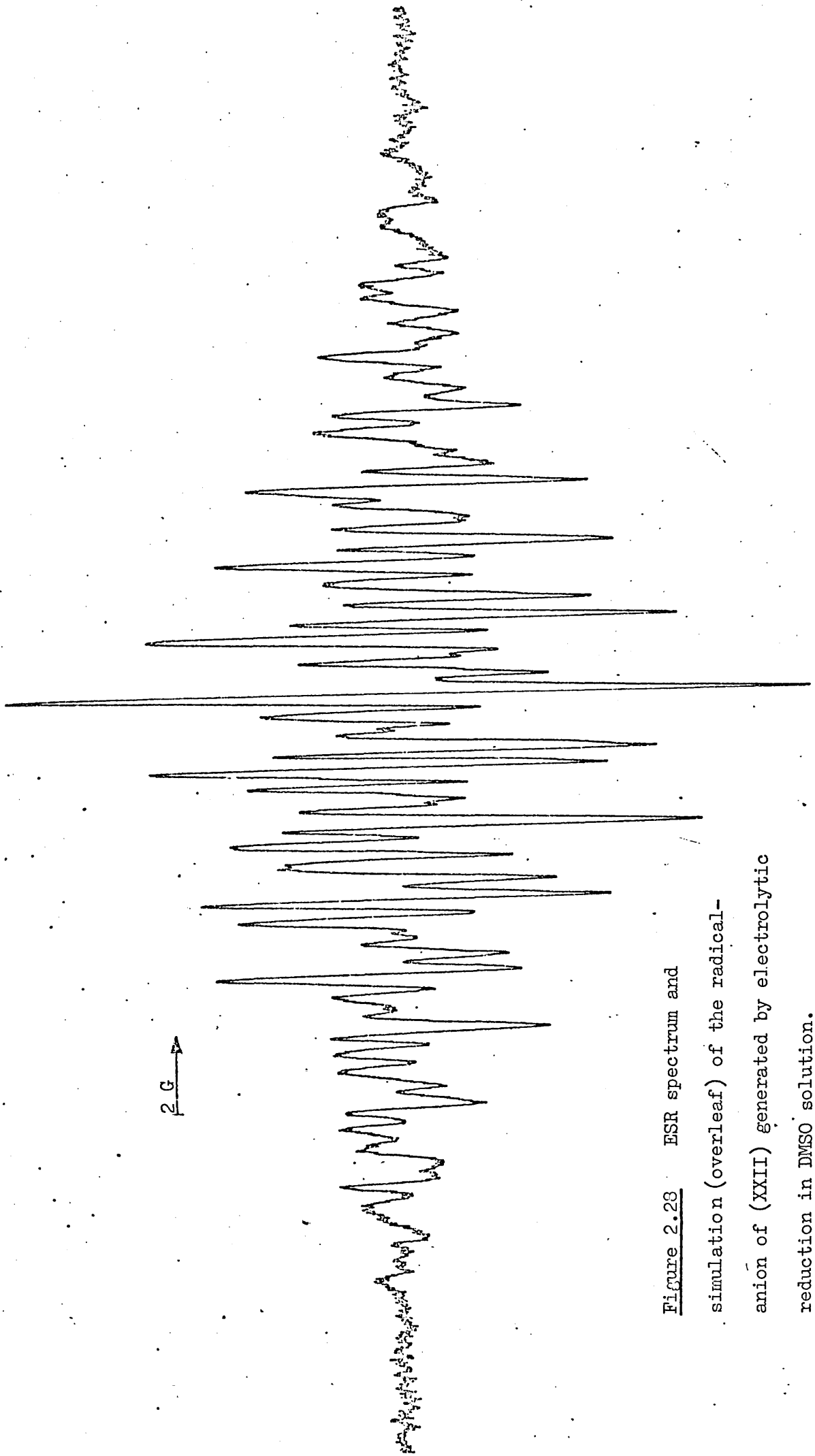

Figure 2.23 ESR spectrum and simulation (overleaf) of the radical-anion of (XXII) generated by electrolytic reduction in DMSO solution.

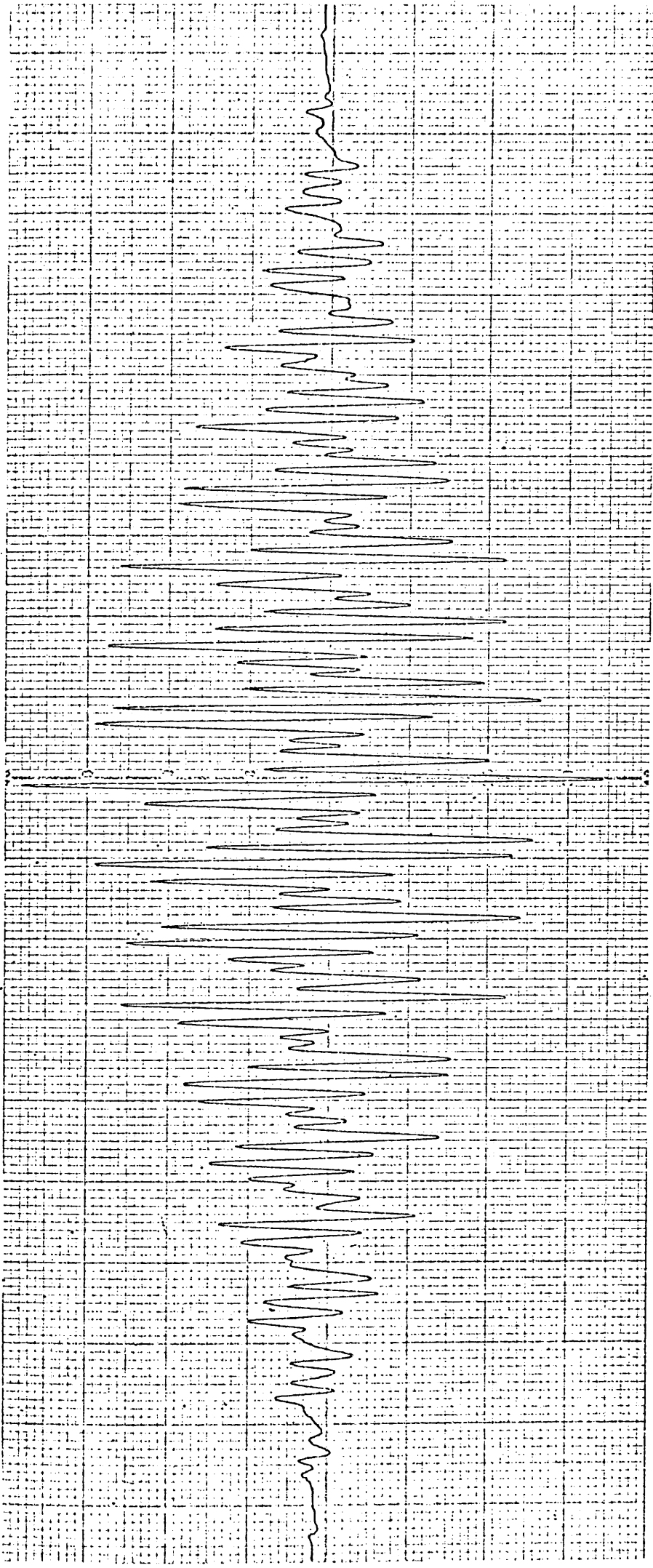

Figure 2.28

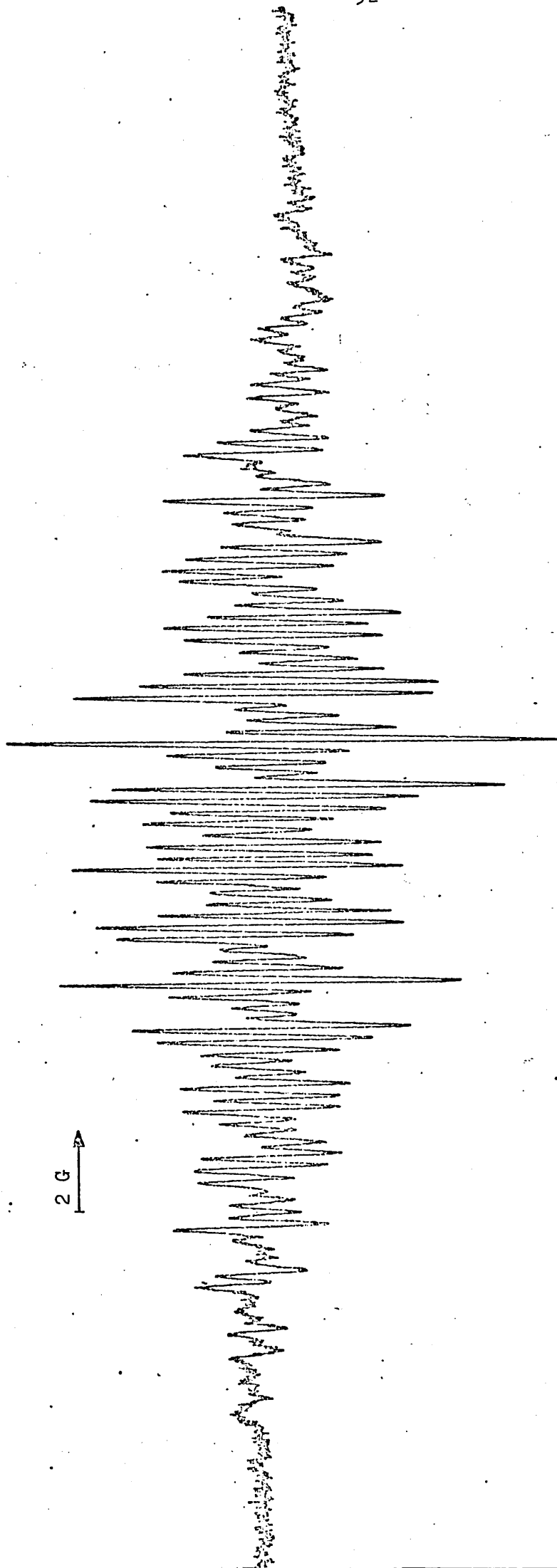

Figure 2.29 ESR spectrum and simulation (overleaf) of (XXIII) in basic DMSO solution.

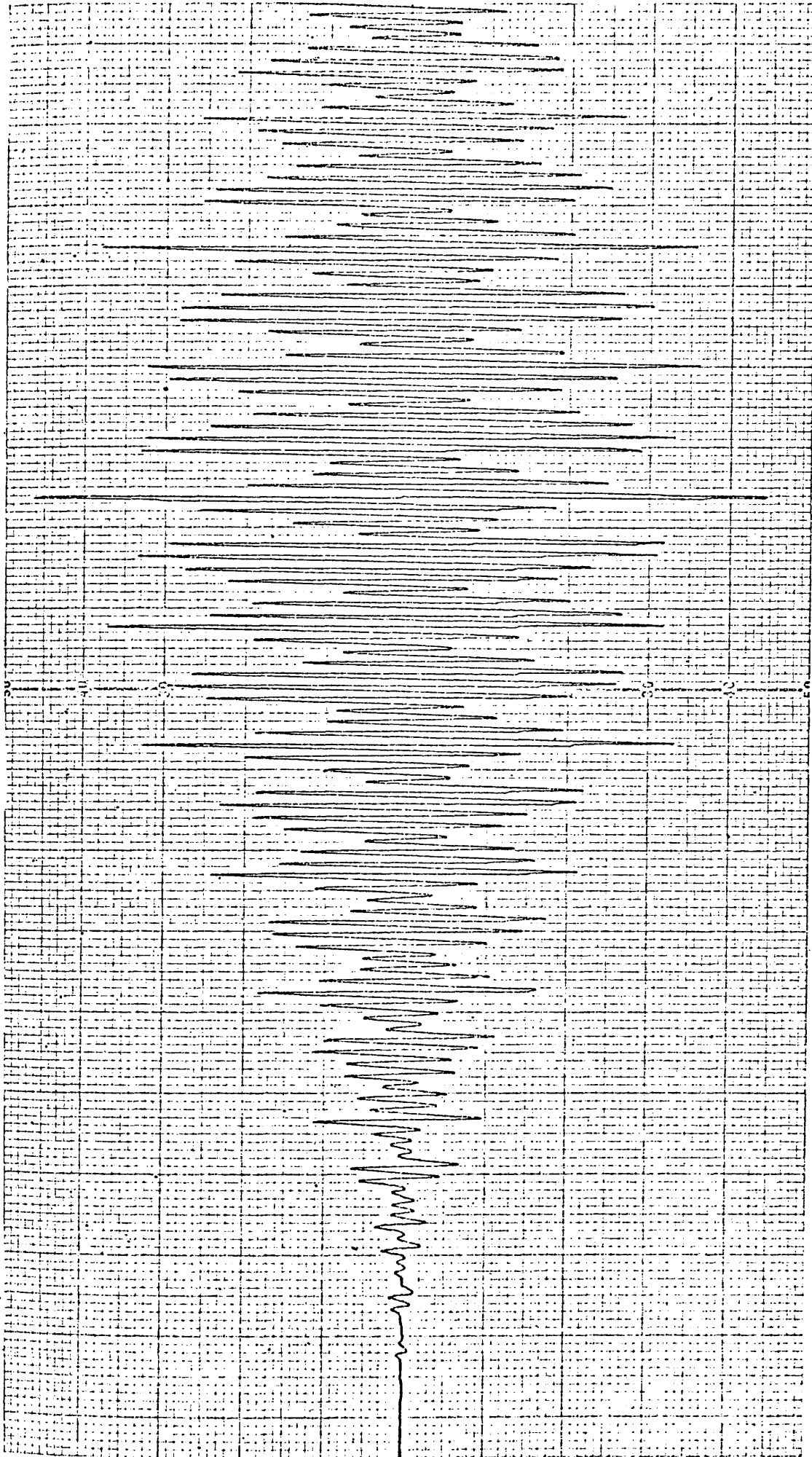

Figure 2.29

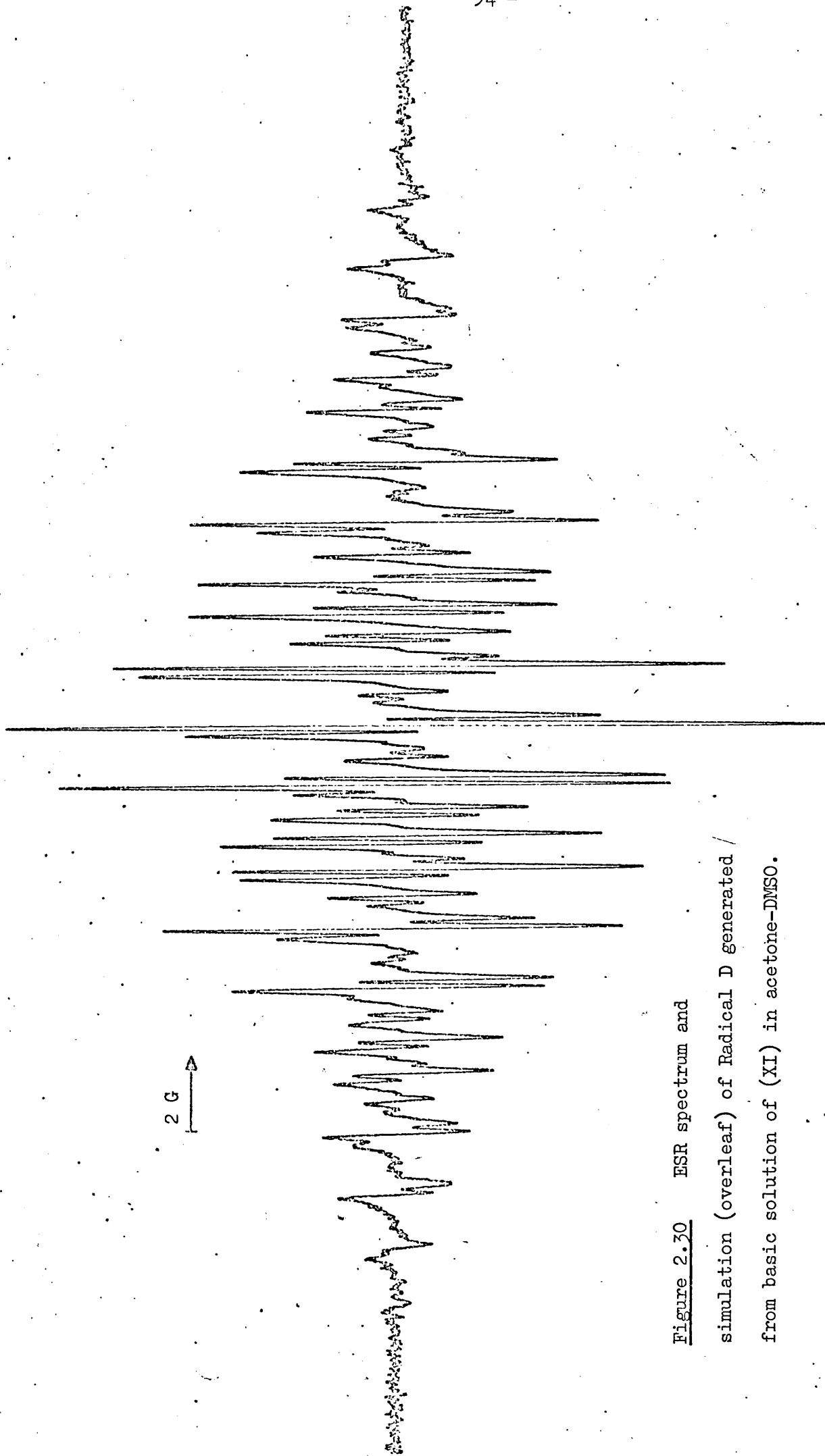

Figure 2.30 ESR spectrum and simulation (overleaf) of Radical D generated from basic solution of (XI) in acetone-DMSO.



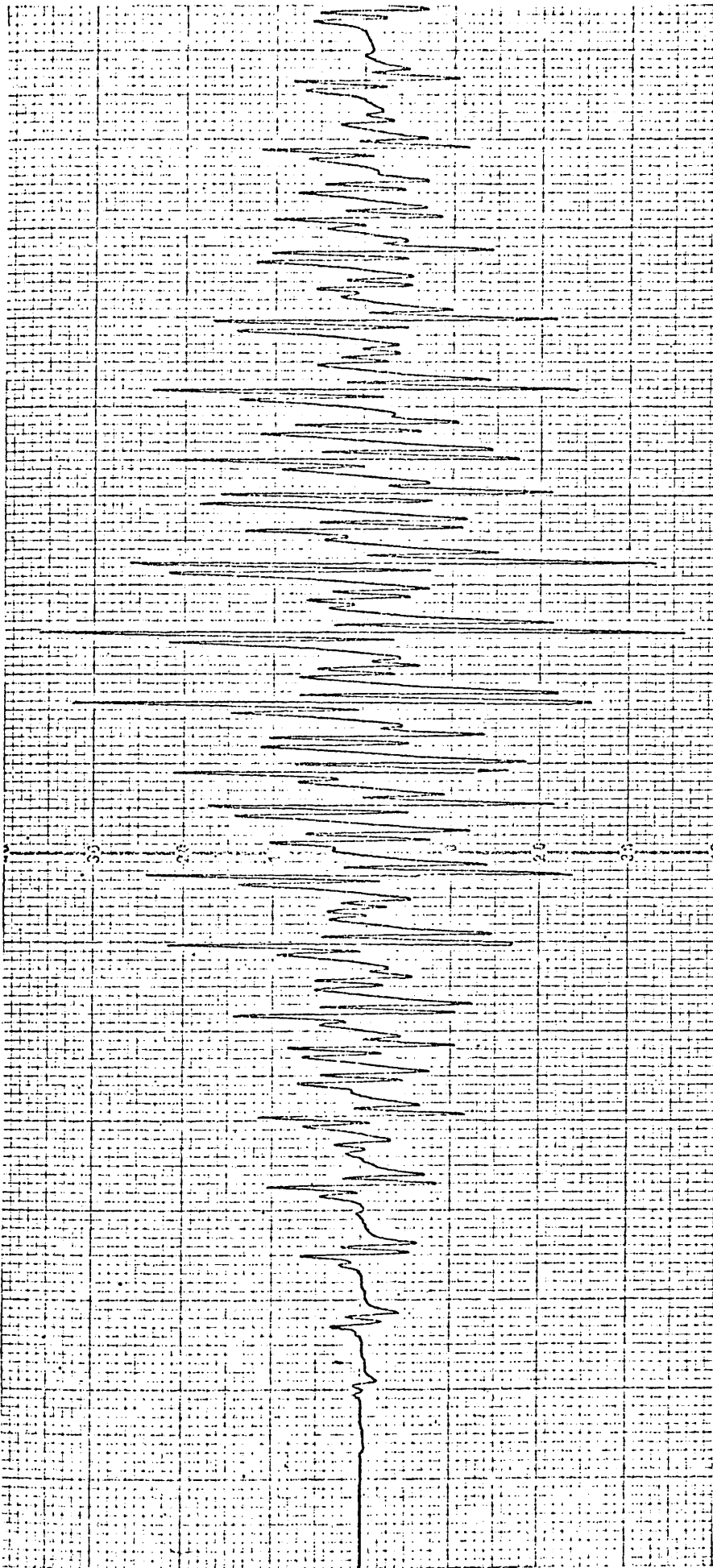

Figure 2.30

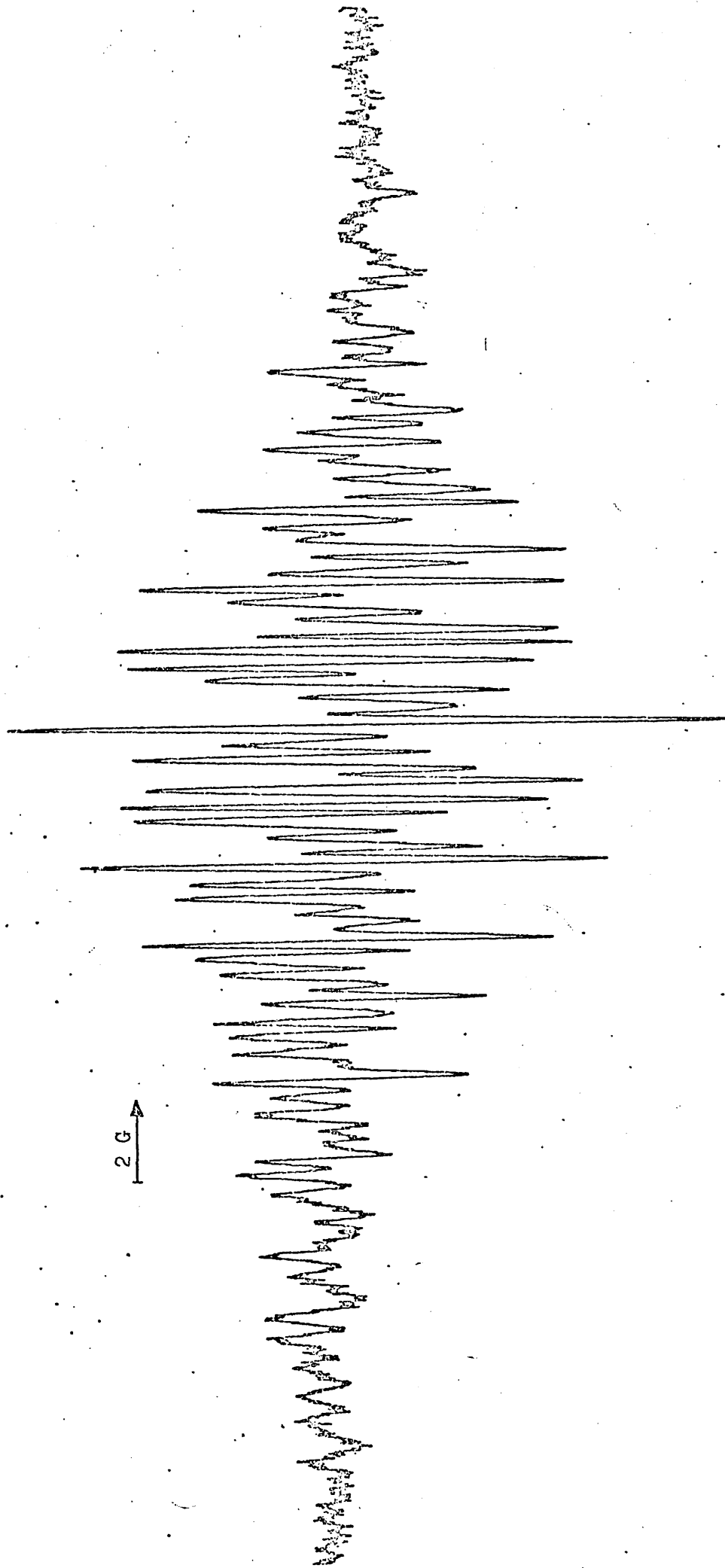

Figure 2.31 ESR spectrum and simulation (overleaf) of a dimeric radical-anion derived from (XII).

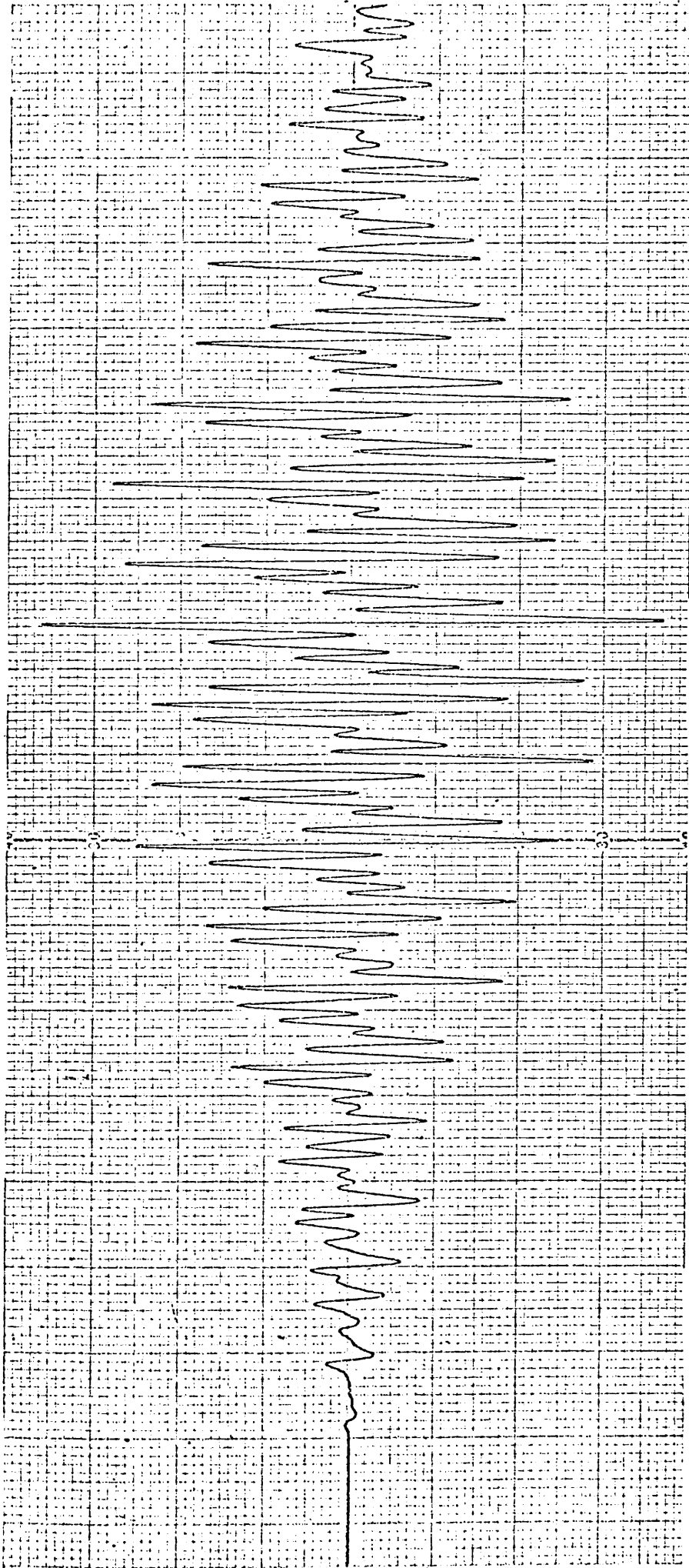

Figure 2.31

## Section 2.4

### Linewidth Variations in the Nitrogen- and Fluorine- Containing Radicals Detected

The spectra of the nitroxides, nitroso-radical-anions and dimeric radical-anions all exhibited line-broadening. This effect is different from other line-broadening mechanisms in that it causes the spectrum to appear unsymmetrical. The spectrum obtained does not depend upon the microwave power level, nor the direction of magnetic field sweep, as would be expected if saturation, or change in the radical concentration respectively, were responsible.

The effect is often very striking in the spectra of transition metal ions.<sup>86</sup> At room temperature, the broadening is only usually apparent for nitrogen- and fluorine- containing free radicals.<sup>87,88</sup> The broadening is temperature dependent and governed by the viscosity of the solution. As the viscosity of the solvent increases the tumbling rate of the radical decreases and anisotropic properties of the  $g$ -factor and hyperfine interactions are no longer averaged to zero. (Each property is now described in cartesian coordinates by a tensor, a  $3 \times 3$  matrix). For relatively rapid tumbling the width of a line depends on the amount by which its position varies as the radical tumbles, so that

$$W \approx (\Delta\omega)^2 \tau_c$$

where,  $W$  is the linewidth,  $\tau_c$  is the correlation time for tumbling

(approximately the time for rotation through 1 radian about a principal axis) and  $\frac{(\Delta\omega)}{(2\pi)}$  is the shift in resonance frequency. For a molecule with anisotropic  $g$ - and hyperfine(A-)tensors there are two corresponding contributions to  $\Delta\omega$ ;

$$\Delta\omega = (\Delta\omega)_g + (\Delta\omega)_A$$

so that,

$$W \sim [(\Delta\omega)_g^2 + (\Delta\omega)_A^2 + (\Delta\omega)_g(\Delta\omega)_A] \tau_c$$

The effect of each term is given in Figure 2.32, and only the "cross-term"  $(\Delta\omega)_g(\Delta\omega)_A \tau_c$  affects the position of all the hyperfine lines differently. This contribution therefore, depends on  $M_I$  (the nuclear quantum number for the e.s.r. transition). Thus the line-widths can be fitted to the expression

$$W = A + BM_I + CM_I^2 \quad (\text{xii})$$

where A, B and C are constants and  $A \equiv (\Delta\omega)_g^2 \tau_c$ ;  $B \equiv (\Delta\omega)_g(\Delta\omega)_A \tau_c$  and  $C \equiv (\Delta\omega)_A^2 \tau_c$ . More precise expressions for A, B and C have been determined<sup>89</sup> and equation (xii) may be extended to systems containing more than one magnetic nucleus:<sup>88</sup>

$$W_i = A + \sum_i B_i M_{I_i} + \sum_i C_i M_{I_i}^2 + \sum_{i < j} D_{ij} M_{I_i} M_{I_j} \quad (\text{xiii})$$

where there are now coefficients  $B_i$  and  $C_i$  for each magnetic nucleus and cross-terms  $D_{ij}$ , which depend on the corresponding hyperfine coupling tensors.

Figure 2.32

The contributions to the linewidth from modulation of the  $g$ - and hyperfine properties of the radical.

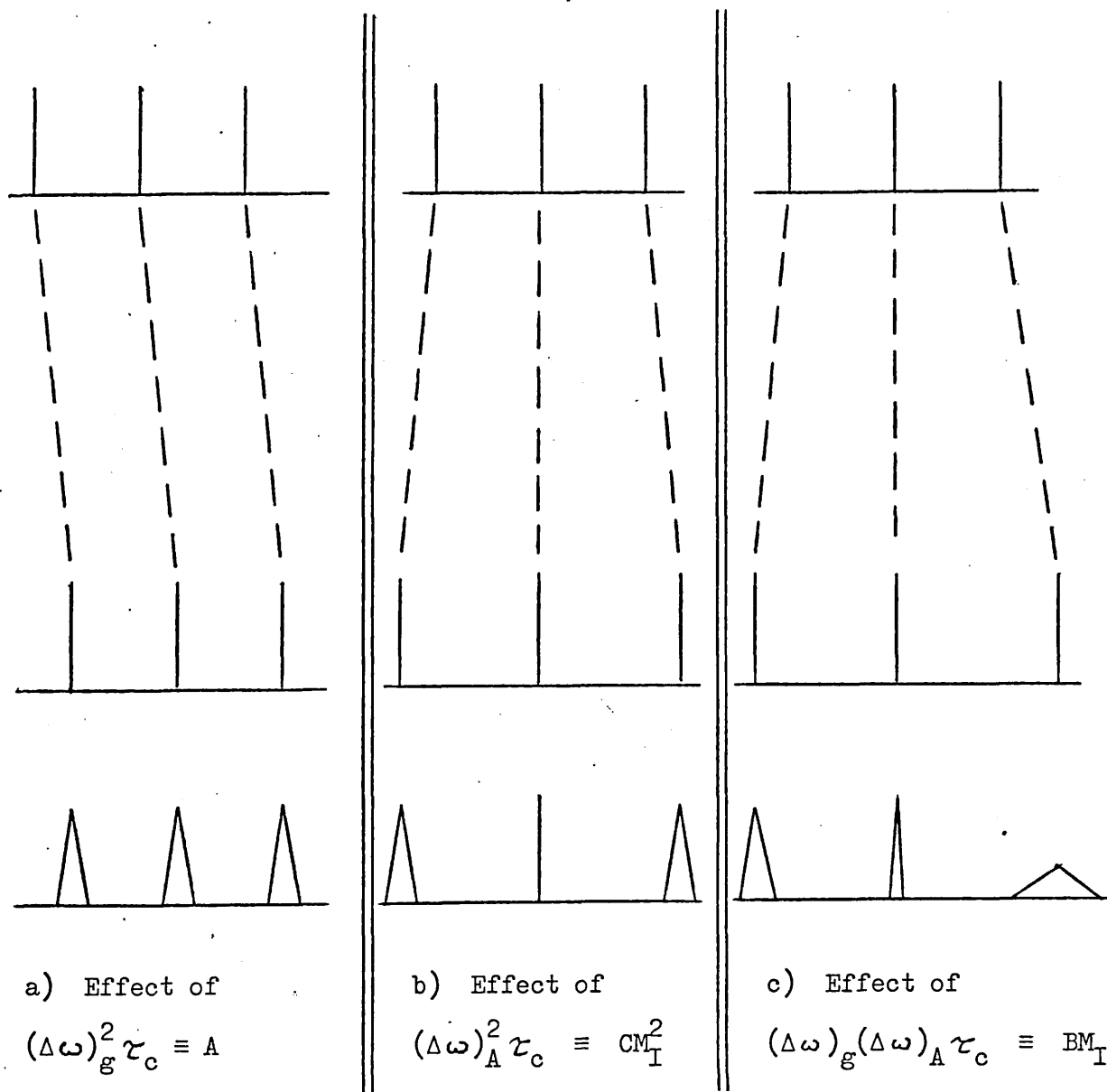

This equation has been applied to the three monofluoronitrobenzene radical-anions.<sup>88</sup> For radicals containing groups of nuclei with the same isotropic hyperfine coupling, degenerate transitions occur giving a line which is a superposition of lines rather than a single line, and there is no simple relationship between the linewidth and the amplitude. However, deviation from a Lorentzian shape is usually small and equation (xii) may be used.<sup>62,89</sup>

Of the spectra obtained which show this line-broadening effect, the more interesting ones are those which contain both nitrogen and fluorine, since the effect is quite pronounced for these elements<sup>62,87,88</sup> and their combined effects may be a good test of equation (xii). In order to determine accurately the relative widths of the hyperfine lines in a spectrum, little overlap of the lines is necessary. For this reason the spectra of the dimers from fluorine-substituted nitrosobenzenes were not examined in detail, but instead the radical-anion obtained from pentafluoronitrosobenzene was used (Section 2.1L).

Determination of the Coefficients of Equation (xii) for a Tetrafluoro-nitrosobenzene radical-anion.

The spectrum of the tetrafluoronitrosobenzene radical-anion consists of 27 lines (Figure 2.22) generated by two pairs of equivalent fluorine atoms and one nitrogen atom. The spectrum was recorded in both directions of field sweep and the average derivative peak-to-peak amplitude was measured for each time. The amplitudes of the derivative signal are inversely proportional to the square of the width, so that the amplitudes are much more sensitive to linewidth differences than the width itself.

Experimental relative linewidths ( $W_i$ ) were calculated according to the equation.

$$W_i = \frac{1}{\sqrt{(a_r)_i}} = [(D_i/a_i) (a_{14}/D_{14})]^{1/2} \quad (\text{xiii})$$

as  $(a_r)_i = \left[ \frac{a_i}{D_i} / \frac{a_{14}}{D_{14}} \right]$  where  $(a_r)_i$  is the amplitude of line  $i$  relative to the centre line (line 14) and  $a_i$  and  $D_i$  are the amplitude and degeneracy of line  $i$  respectively.

Since the positions of the lines in the spectrum are independent of the signs of the hyperfine splittings, only the moduli of the quantum numbers that characterise a particular line can be assigned. Consequently, the experimental data are expressed in terms of 'spectral index numbers' ( $\tilde{M}_x$  in place of  $M_x$ ) which are defined here as being positive on the low-field side of the spectrum and are thus the same as the appropriate quantum number ( $M_x$ ), if the splitting constant is positive. In particular, equation (xii) becomes,

$$W_i = 1 + B_N \tilde{M}_N + C_N \tilde{M}_N^2 + {}^o B_F \tilde{M}_F + {}^o C_F \tilde{M}_F^2 + {}^m B_F \tilde{M}_F + {}^m C_F \tilde{M}_F^2 \\ + {}^o D_{NF} \tilde{M}_N \tilde{M}_F + {}^m D_{NF} \tilde{M}_N \tilde{M}_F + D_{FF} \tilde{M}_F \tilde{M}_F$$

where  $\tilde{M}_N$ ,  $\tilde{M}_F$  and  $\tilde{M}_F$  are the index numbers for the nitrogen, ortho-fluorine and meta-fluorine nuclei respectively. The experimental parameters for each line are given in Table 2.7, from which values for the  $B_X$ ,  $C_X$  and  $D_{XY}$  coefficient can be obtained.



Table 2.7

Experimental and Calculated Relative Line-Widths ( $W_i$ ) for  $XG_F NO_2$ .

Line Number	$\tilde{M}_N$	Spectral index numbers	$\tilde{M}_F$	$m_M$	Degeneracy	Relative Amplitude $(a_r)_i$	Relative Width $W_i$	Relative Width $W'_i$	Difference $(W'_i - W_i)$
1	+1	+1	+1	+1	1	0.890	1.060	1.103	+0.043
2	+1	+1	+1	0	2	1.044	0.979	0.979	
3	+1	+1	+1	-1	1	1.212	0.908	0.913	+0.005
4	+1	0	0	+1	2	1.168	0.925	0.930	+0.005
5	+1	0	0	0	4	1.303	0.876	0.876	
6*	0	+1	+1	+1	1	0.995	1.003	0.919	-0.084
7	+1	0	0	-1	2	1.313	0.873	0.880	+0.007
8	0	+1	+1	0	2	1.326	0.868	0.868	
9*	+1	-1	-1	-1	1	1.589	0.793	0.801	+0.008
10*	0	+1	+1	-1	1	1.317	0.871	0.875	+0.004
11	+1	-1	-1	0	2	1.381	0.851	0.818	-0.034
12	0	0	0	+1	2/	1.040	0.981	0.981	
13	+1	-1	-1	-1	1	1.157	0.930	0.891	-0.039
14	0	0	0	0	4	1.0	1.0	1.0	
15	-1	+1	+1	+1	1	1.292	0.880	0.889	+0.009
16	0	0	0	-1	2	0.862	1.077	1.077	

Continued/...

17	-1	+1	0	2	1.272	0.887	0.911	+0.024
18*	0	-1	+1	1	0.751	1.178	1.087	-0.091
19*	-1	+1	-1	1	0.990	1.005	0.991	-0.014
20	0	-1	0	2	0.723	1.176	1.176	
21	-1	0	+1	2	0.725	1.174	1.186	+0.012
22*	0	-1	-1	1	0.428	1.529	1.323	-0.206
23	-1	0	0	4	0.612	1.278	1.278	
24	-1	0	-1	2	0.488	1.431	1.428	-0.003
25	-1	-1	+1	1	0.475	1.451	1.527	+0.076
26	-1	-1	0	2	0.342	1.710	1.689	-0.021
27	-1	-1	-1	1	0.262	1.954	1.909	-0.045

a: Lines partially overlapped are marked by an asterisk

b: Calculated from equation (xiii), the average over a series of spectra is given:

c: Calculated from equation (xii).

$$\begin{array}{lll}
 B_N = -0.201 & {}^oB_F = -0.154 & {}^mB_F = -0.048 \\
 C_N = +0.077 & {}^oC_F = +0.022 & {}^mC_F = +0.029 \\
 {}^oD_{NF} = +0.235 & {}^mD_{NF} = +0.073 & D_{FF} = +0.070
 \end{array}$$

These values for the coefficients were substituted into equation (xii) and used to calculate values for the relative width ( $W_i'$ , column 8, Table 2.7).

The calculated  $W_i'$  values can be seen to give a reasonable fit to the experimentally observed values. The largest discrepancies occur for the high-field lines, where the line amplitude is smaller and the percentage error in its determination is greater, and also where there is partial overlap. Another source of error is that the equation is strictly applicable only to non-degenerate lines. Also other line broadening mechanisms not taken into account may not be insignificant.<sup>90</sup>

The calculated values of the coefficients show that  $|B_X| > |C_X|$  so that the  $g$ - and hyperfine-tensor cross-term dominates. Also,  $|B_N| > |{}^oB_F| > |{}^mB_F|$  and  $C_N > {}^oC_F \approx {}^mC_F$  following the same order expected for their relative spin densities. In favourable circumstances the C coefficient is proportional to the square of the spin density on the atom.<sup>91</sup>

From the expected signs of the spin density distribution in the radical; (Section 1.1)

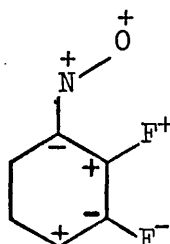

the signs of the splitting constants and the coefficients  $B_X$ ,  $C_X$  and  $D_{XY}$  may be determined. Equation (xii) becomes,

$$\begin{aligned} W_i = & 1 - 0.201M_N + 0.077M_N^2 - 0.154M_F^{\circ} + 0.022M_F^{\circ 2} + 0.048M_F^m \\ & + 0.029M_F^m 2 + 0.235M_N^{\circ} M_F - 0.073M_N^m M_F - 0.070M_F^{\circ} M_F^m \quad (\text{xiv}) \end{aligned}$$

CHAPTER 3

E.S.R. STUDIES OF THE REACTION OF C-NITROSO COMPOUNDS WITH ALKYL HALIDES  
IN THE PRESENCE OF A BASE (REACTION (xv)).

Section 3.1

Outlined in the introduction was the ability of C-nitroso-compounds to form a radical-anion on reaction with a variety of bases. Thus the application of C-nitroso-compounds as "spin-traps" may be suspect for reactions involving bases. Consequently, the reaction of mercaptides with alkyl halides in the presence of a C-nitroso "spin-trap" (involving a proposed <sup>60</sup>S<sub>RN</sub>1 mechanism), was reinvestigated.

In fact the appropriate alkyl aryl nitroxide was observed by e.s.r. spectroscopy when certain nitrosoarenes were allowed to react with alkyl halides in the presence of a base (most conveniently sodium hydroxide). Also when an alkyl halide was added to a solution of a radical-anion, its spectrum was replaced by that of the corresponding alkyl aryl nitroxide.

The solvents used for the reaction were generally ethanol, DMF and DMSO, of which the last proved to be the most suitable. The bases used were sodium hydride, sodium methoxide and potassium t-butoxide, added as solids, and sodium hydroxide added as a 10% aqueous solution. Alkyl halides investigated were methyl, ethyl, isopropyl and n-propyl iodides, benzyl and p-nitrobenzyl bromides, 1,3 dibromopropane, tribromomethane (bromoform), tri-iodomethane (iodoform), di-iodomethane and 2-bromo-2-phenyl-N,N-dimethylethylamine hydrobromide (PhCHBr.CH<sub>2</sub>.NMe<sub>2</sub>HBr). The results for individual nitroso compounds are given below, followed by

the experiments performed to elucidate the mechanism. The spectroscopic parameters of the nitroxide radicals are collected in Table 3.1.

### 3.1 A Nitrosobenzene

When aqueous sodium hydroxide was added dropwise to a solution of nitrosobenzene and methyl iodide in ethanol, DMF or DMSO (equation (xvi), R = methyl) the e.s.r. spectrum of methyl phenyl nitroxide was detected (Figure 3.1).

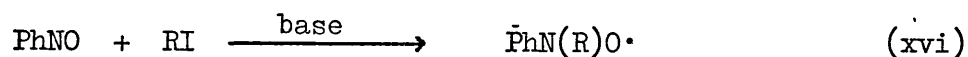

The splitting constants agree with those obtained previously<sup>92</sup> (Table 3.1) and the same spectrum was obtained when the reaction was performed in the absence of molecular oxygen. The identity of the radical observed was confirmed by mixing aqueous titanium III trichloride and aqueous hydrogen peroxide with nitrosobenzene in DMSO. The red solution produced gave the e.s.r. signal of methyl phenyl nitroxide, formed by trapping of methyl radicals<sup>93</sup> by nitrosobenzene:

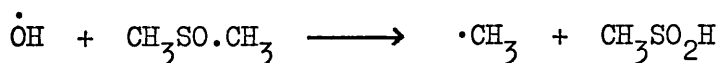

Similar results were obtained for reaction (xvi), R = ethyl or isopropyl (for example, Figure 3.2). The splitting constants for ethyl phenyl nitroxide agree with those in the literature, except that the  $\gamma$ -

methyl coupling is resolved (Table 3.1). When the reaction was performed using  $d_5$ -nitrosobenzene the spectrum detected showed only the couplings expected from the alkyl group and the nitrogen atom in (XXIV), confirming the assignment of the couplings.

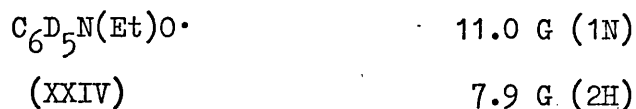

Ethyl phenyl nitroxide was also observed from the photolysis of nitrosobenzene, ethyl iodide and tri-n-butyltin hydride in DMF solution inside the e.s.r. spectrometer cavity.

However, the splitting constants observed for isopropyl phenyl nitroxide differ slightly from a previous report:<sup>94</sup>

$a_N$ (1N) =	11.15	11.1 <sup>94</sup>	G
$a_H$ (1H) =	3.25	2.8	G
$a_H$ (3H) =	2.75	2.8	G
$a_H$ (2H) =	1.00	0.9	G
$a_H$ (6H) =	0.20		G

and  $C_6D_5N[CH(CH_3)_2]O\cdot$  (Figure 3.3) has:

$a_N$ (1N) =	11.20	G
$a_H$ (1H) =	3.30	G

It appears that previously<sup>94</sup> the spectrum was observed under conditions of poor resolution, when the  $\beta$ -hydrogen splitting appears to

be equivalent to the ortho- and para- hydrogen splittings, such as in Figure 3.4.

Reaction of nitrosobenzene and polyhalogenomethanes in the presence of base also generated long-lived radical products. The results are discussed in Section 3.12.

### 3.1 B 2,4,6-Tribromonitrosobenzene (VI)

The reaction between (VI) and methyl iodide gave the corresponding nitroxide (Figure 3.5) using the following base and solvent combinations: (Sodium hydride and DMSO), (sodium methoxide and DMSO) (aqueous sodium hydroxide and DMSO), (potassium t-butoxide and t-butyl alcohol), (potassium t-butoxide and t-butyl alcohol/DMF), (aqueous sodium hydroxide and DMF) and (aqueous sodium hydroxide and acetone). The identification was confirmed by obtaining the same spectrum from the action of aqueous titanium III trichloride and hydrogen peroxide on DMSO in the presence of (VI). The same nitroxide was also observed from the photolysis, in the spectrometer cavity, of a solution of (VI) and methyl iodide in DMF. The reaction of (VI) with  $d_3$ -methyl iodide and aqueous sodium hydroxide in DMSO solution gave a spectrum assigned to 2,4,6-tribromophenyl  $d_3$ -methyl nitroxide (Figure 3.6) with splitting constants:

13.4 G (1N)

0.6 G (2H)

1.9 G (3D) (1:3:6:7:6:3:1) - approximately

one sixth the equivalent  $^1\text{H}$  splitting, as would be expected.<sup>1e</sup> Similarly, with ethyl, isopropyl and n-propyl iodides (Table 3.1) and with benzyl bromide [13.50 G (1N), 0.65 G (2H), 10.50 G (2H)] the corresponding



nitroxides were detected.

However, reaction of (VI) with ethyl, isopropyl and n-propyl (but not methyl) iodides with aqueous sodium hydroxide, added dropwise, in DMF or DMSO sometimes gave rise to a second persistent, nitrogen-centred radical as well as the expected nitroxide. This second type of radical (XXV) was favoured by higher hydroxide ion concentrations than were required to generate the nitroxide, which decayed relatively rapidly under more basic conditions. The nature of these radicals is discussed in Section 3.11 and their spectral parameters are:

	Ethyl	Isopropyl	n-Propyl
$a_N$ (1N) G	9.45	9.6	9.45
$a_H$ G	1.25 (2H)	1.20 (1H)	1.30 (2H)
g-value	2.0054	2.0055	2.0054

(Figure 3.7)

When (VI) and base were allowed to react in the presence of iodobenzene phenyl 2,4,6-tribromo-phenyl nitroxide was not detected.

### 3.1 C 2,6-Dibromonitrosobenzene (VII)

(VII) reacted with methyl iodide and aqueous sodium hydroxide (added dropwise) in DMSO, DMF or ethanol solution to give methyl 2,6-dibromophenyl nitroxide (Figure. 3.8). The para-H splitting constant is smaller than the meta-H value, in contrast to couplings for alkyl phenyl nitroxides (ortho ~ para > meta). This effect was also seen for alkyl

2,6-dichlorophenyl nitroxides (Table 3.1) and ortho-substituted t-butyl aryl nitroxides<sup>64</sup> and is discussed in Section 1.1. Methyl 2,6-dibromophenyl nitroxide was also generated by trapping methyl radicals, produced from DMSO and  $\cdot\text{OH}$ <sup>93</sup>, with (VII).

The corresponding nitroxides were detected when ethyl, isopropyl (Figure 3.9) and n-propyl iodides were allowed to react with (VII) in the presence of hydroxide ion (Table 3.1). As with 2,4,6-tribromonitrosobenzene, a second type of persistent radical was observed in the reactions with ethyl and with n-propyl iodides. Similar radicals were not detected with methyl or isopropyl iodide. The splitting constants are very similar to those obtained in the (VI) systems (Table 3.5) and show small increases (ca. 0.2 G) with increasing water concentration (see Section 3.11).

### 3.1 D 2,4,6-Trichloronitrosobenzene (VIII)

(VIII) gave the appropriate nitroxide on reaction with methyl, ethyl, isopropyl (Figure 3.10) and n-propyl iodides in the presence of hydroxide ion. The radicals characteristically exhibited a nitrogen splitting of ca. 13 G, a m-hydrogen 1:2:1 triplet of ca. 0.7 G and a g-value of 2.0063. The  $\beta$ -hydrogen splittings for the alkyl group varied in the order methyl > ethyl > n-propyl > isopropyl, for all the nitroxide series investigated (Table 3.1).  $\beta$ -Hydrogen couplings are known to depend on the relative orientation of the C-H bond with respect to the  $p_z$  orbital containing the unpaired electron.<sup>95</sup> The magnitude of the coupling is given by:

$$a_{\beta\text{-H}} = B_0 + B \cos^2\theta$$

where  $B_0$  has a value of 3 to 4 G, B is a constant, and  $\theta$  is the dihedral angle.

Thus the preferred dihedral angle between the  $C_{\beta-H}$  bond and the  $p_z$  orbital in the alkyl aryl nitroxides is greatest when the alkyl group is isopropyl. An exception to the series was found for 2,4,6-tri-*t*-butyl phenyl alkyl nitroxides,<sup>95</sup> where the coupling to  $\beta$ -H varied in the order secondary > primary > methyl.

The assignments were checked by generating the nitroxides by the photolysis of the alkyl iodide, and (VIII) with or without tri-*n*-butyltin hydride. Methyl 2,4,6-trichlorophenyl nitroxide was also observed from the trapping of methyl radical generated by the attack of hydroxyl radical on DMSO.<sup>93</sup> The appropriate nitroxide was not seen when aqueous sodium hydroxide was added to (VIII) and *t*-butyl bromide in DMF or DMSO.

In agreement with the results using 2,4,6-tribromonitrosobenzene, a second long-lived radical product was observed for the reactions with ethyl, isopropyl (Figure 3.11) and *n*-propyl iodides.

Spectral parameters:

	Ethyl	Isopropyl	<i>n</i> -propyl
$a_N$ (1N) G	9.60	9.75	9.60
$a_H$ G	1.20 (2H)	1.15 (1H)	1.30 (2H)
$g$ -value	2.0047	2.0047	2.0047
Solvent	DMSO	DMSO	DMSO

(+ ca. 2%  $H_2O$ )

Small variations of the splitting constants with change in solvent were noticed; for example, with n-propyl iodide,  $a_N = 9.80$  G,  $a_H = 1.35$  G (2H) in DMF + ca. 2% H<sub>2</sub>O. The g-value measured for the above radicals was consistently 2.0047, compared with ca. 2.0055 for the 2,4,6-tribromonitrosobenzene and 2,6-dibromonitrosobenzene derivatives.

### 3.1 E 2,6-Dichloronitrosobenzene (IX)

The results obtained with (IX) fitted the pattern emerging for the other di- and tri-halogenated nitrosoarenes. The appropriate nitroxide was generated when (IX) was allowed to react with hydroxide ion in the presence of methyl, ethyl, n-propyl and isopropyl iodides (for example, Figure 3.12 and 3.13). The splitting constants are given in Table 3.1. Also, the secondary radicals were detected at higher alkali concentration with ethyl and n-propyl iodides (Figure 3.14) but not with methyl and isopropyl iodides. The splitting constants (Table 3.5) are very close to those found for the corresponding radicals generated from (VIII).

Table 3.1

E.s.r. Spectral Parameters of the Nitroxides ArN(R)O• detected from Reaction (xv).

The values below are for DMSO + ca. 5% H<sub>2</sub>O solutions unless stated otherwise.

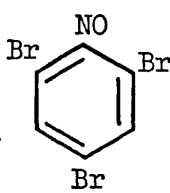
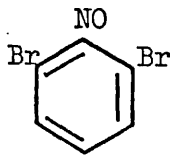
ArNO	Alkyl group <sup>δ</sup>			
	CH <sub>3</sub>	CH <sub>2</sub> CH <sub>3</sub>	CH <sub>2</sub> CH <sub>2</sub> CH <sub>3</sub>	CH(CH <sub>3</sub> ) <sub>2</sub>
C <sub>6</sub> H <sub>5</sub> NO	11.15 (1N) 1.00 (2H) 2.95 (3H) 10.40 (3H)	11.10 (1N) 0.90 (2H) 2.80 (3H) 8.00 (2H)	†   0.25 (3H)	11.55 (1N) 0.95 (2H) 2.80 (3H) 3.55 (1H)
	$g = 2.0055$	2.0055		2.0055
C <sub>6</sub> D <sub>5</sub> NO	++	11.00 (1N) <sup>Δ*</sup> 7.90 (2H)	++	11.20 (1N) <sup>*</sup> 3.30 (1H)
	13.00 (1N) <sup>§</sup> 0.65 (2H) 12.00 (3H)	13.25 (1N) 0.65 (2H) 11.30 (2H)	13.15 (1N) 0.95 (2H) 10.65 (2H)	13.25 (1N) <sup>*</sup>  7.50 (1H)
	$g = 2.0065$	2.0066	2.0066	2.0066
	14.40 (1N) 0.70 (2H) 0.35 (1H) 13.10 (3H)	13.45 (1N) 0.65 (2H) 0.35 (4H) 11.65 (2H)	13.15 (1N) 0.95 (2H) 0.45 (3H) 10.95 (2H)	13.40 (1N) <sup>*</sup>   7.95 (1H)
	$g = 2.0065$	2.0064	2.0065	2.0064

/Continued

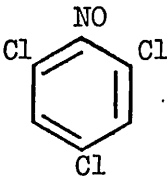
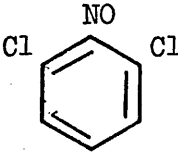
	13.15 (1N)	13.15 (1N)	12.90 (1N) <sup>Δ</sup>	13.15 (1N) <sup>*</sup>
	0.65 (2H)	0.70 (2H)	0.95 (2H)	
	12.15 (3H)	10.65 (2H)	10.05 (2H)	6.00 (1H)
		0.35 (3H)	0.45 (2H)	
	$\underline{g} = 2.0063$	2.0063	2.0064	2.0063
	13.40 (1N)	13.25 (1N)	13.15 (1N)	13.40 (1N) <sup>‡</sup>
	0.65 (2H)	0.70 (2H)	0.95 (2H)	
	0.25 (1H)	0.35 (4H)	0.45 (3H)	
	12.40 (3H)	11.00 (2H)	10.30 (2H)	6.65 (1H)
	$\underline{g} = 2.0062$	2.0062	2.0062	2.0062

δ Splitting constants are given in the unit of Gauss  $\pm 0.05$  G, and the  $\underline{g}$ -values to  $\pm 0.0001$

\* Broad lines due to unresolved coupling

Δ Recorded in DMF solution

†† Not recorded

§ 2,4,6-Br<sub>3</sub>C<sub>6</sub>H<sub>2</sub>N(CD<sub>3</sub>)O• has 13.40 (1N), 0.65 (2H) and 1.90 (3D) G (Figure 3.6)

‡ Not detected

‡ Each line split into a multiplet due to partly resolved coupling.

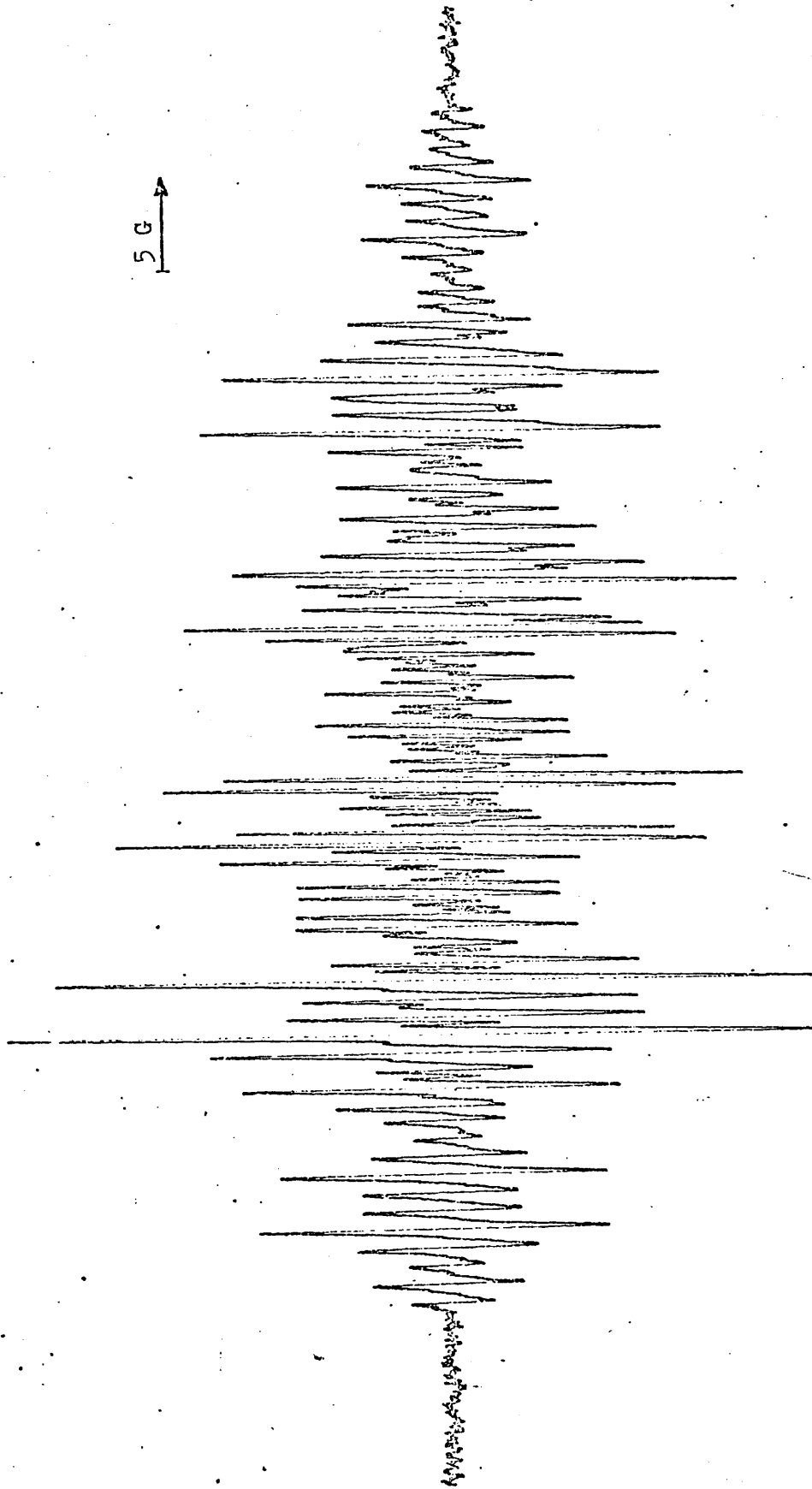

Figure 3.1 ESR spectrum of methyl phenyl nitroxide in aqueous DMSO solution.

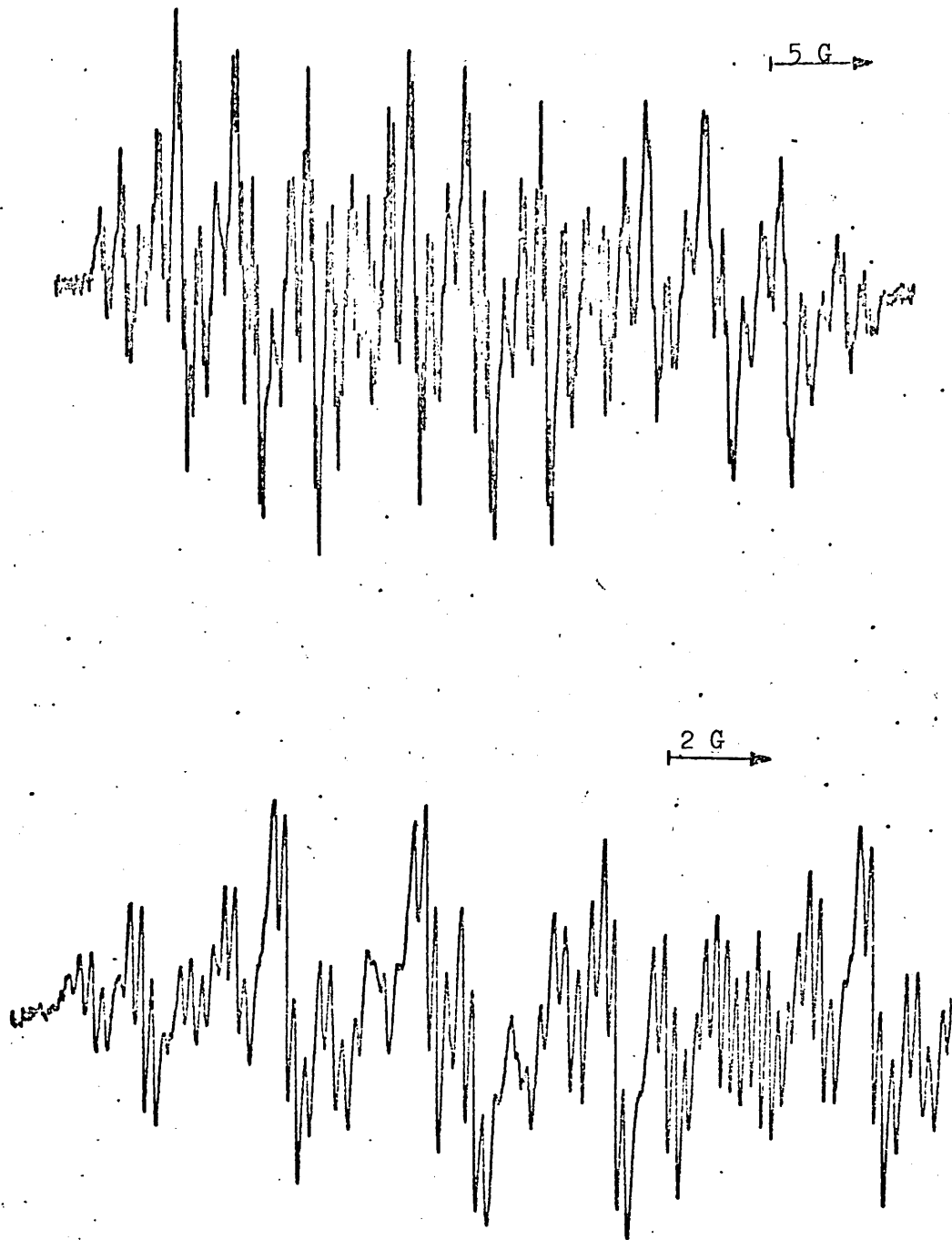

Figure 3.2 ESR spectrum of isopropyl phenyl nitroxide in aqueous DMSO solution. Below is an expansion of the low-field part of the spectrum.



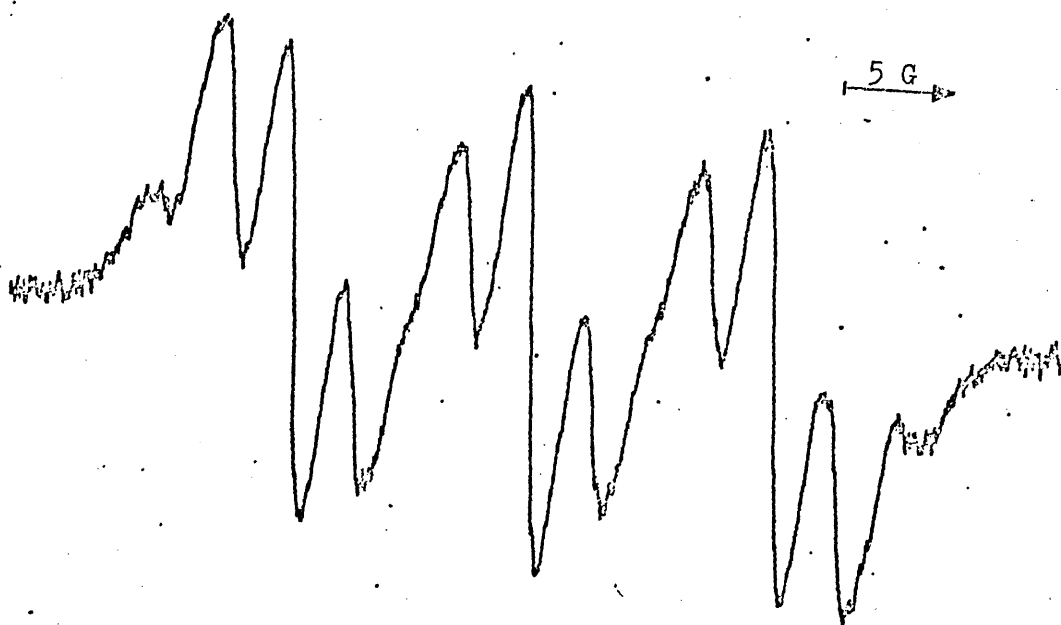

Figure 3.4 Poorly resolved e.s.r. spectrum of isopropyl phenyl nitroxide in aqueous DMSO solution.

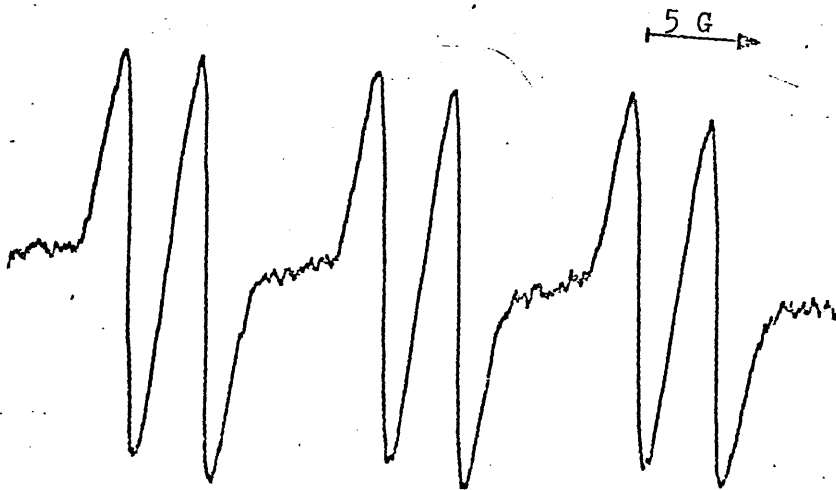

Figure 3.3 ESR spectrum of isopropyl  $d_5$ -phenyl nitroxide in aqueous DMF.

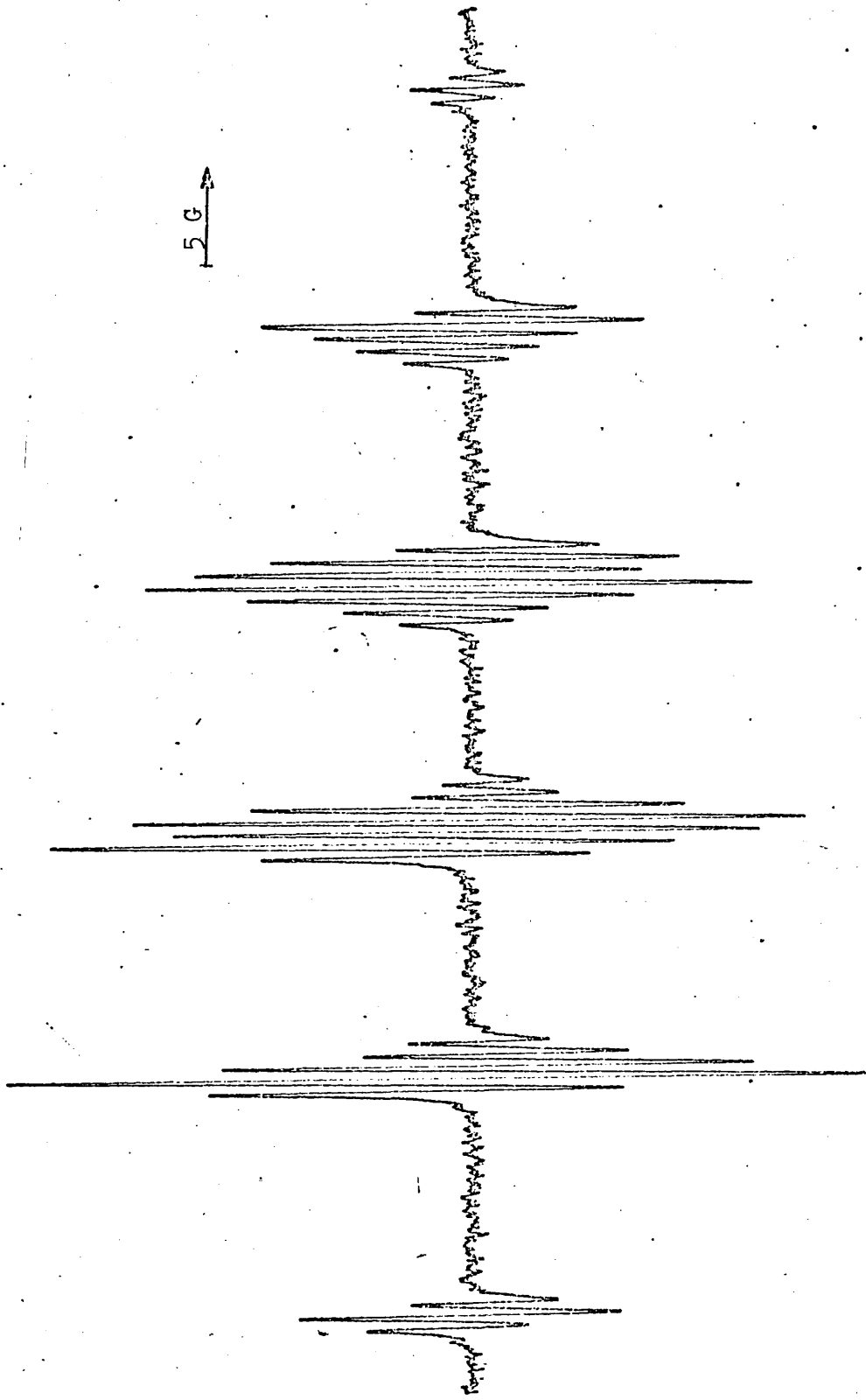

Figure 3.5 ESR spectrum of methyl 2,4,4,6-tribromophenyl nitroxide in aqueous DMSO solution.

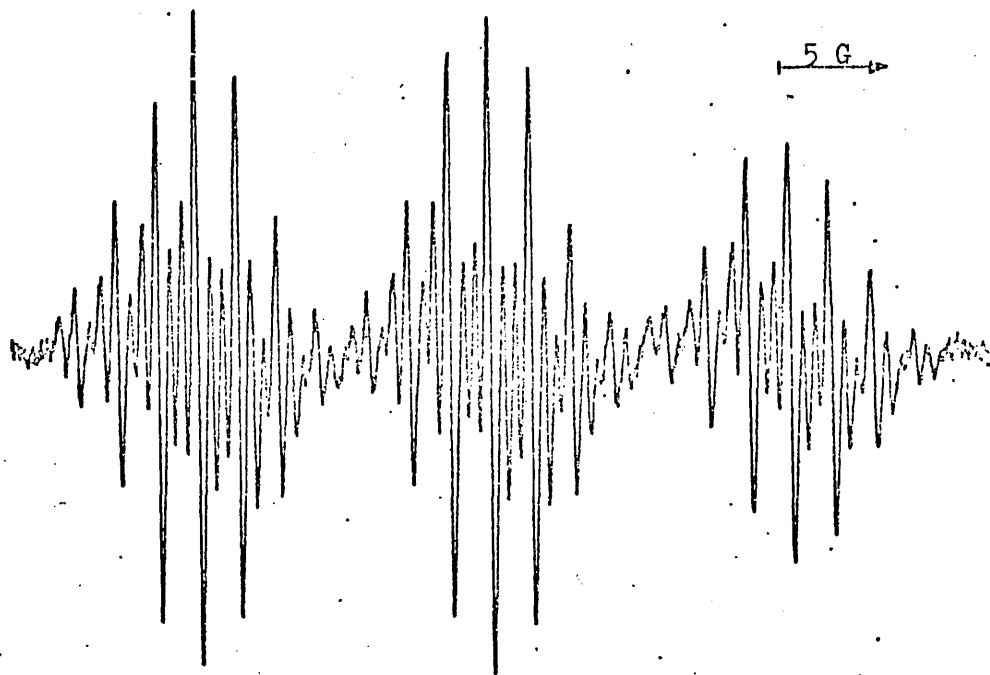

Figure 3.6 ESR spectrum of  $d_3$ -methyl 2,4,6-tribromophenyl nitroxide in aqueous DMSO solution.

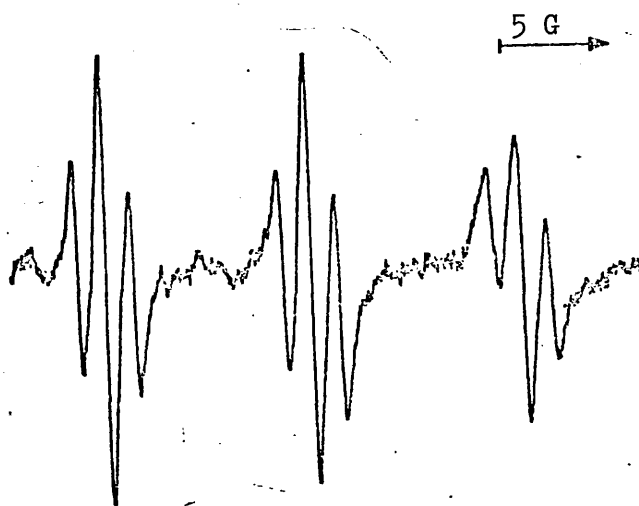

Figure 3.7 ESR spectrum of the secondary persistent radical (Section 3.11) detected in the reaction of (VI) with n-propyl iodide in alkaline aqueous DMSO.

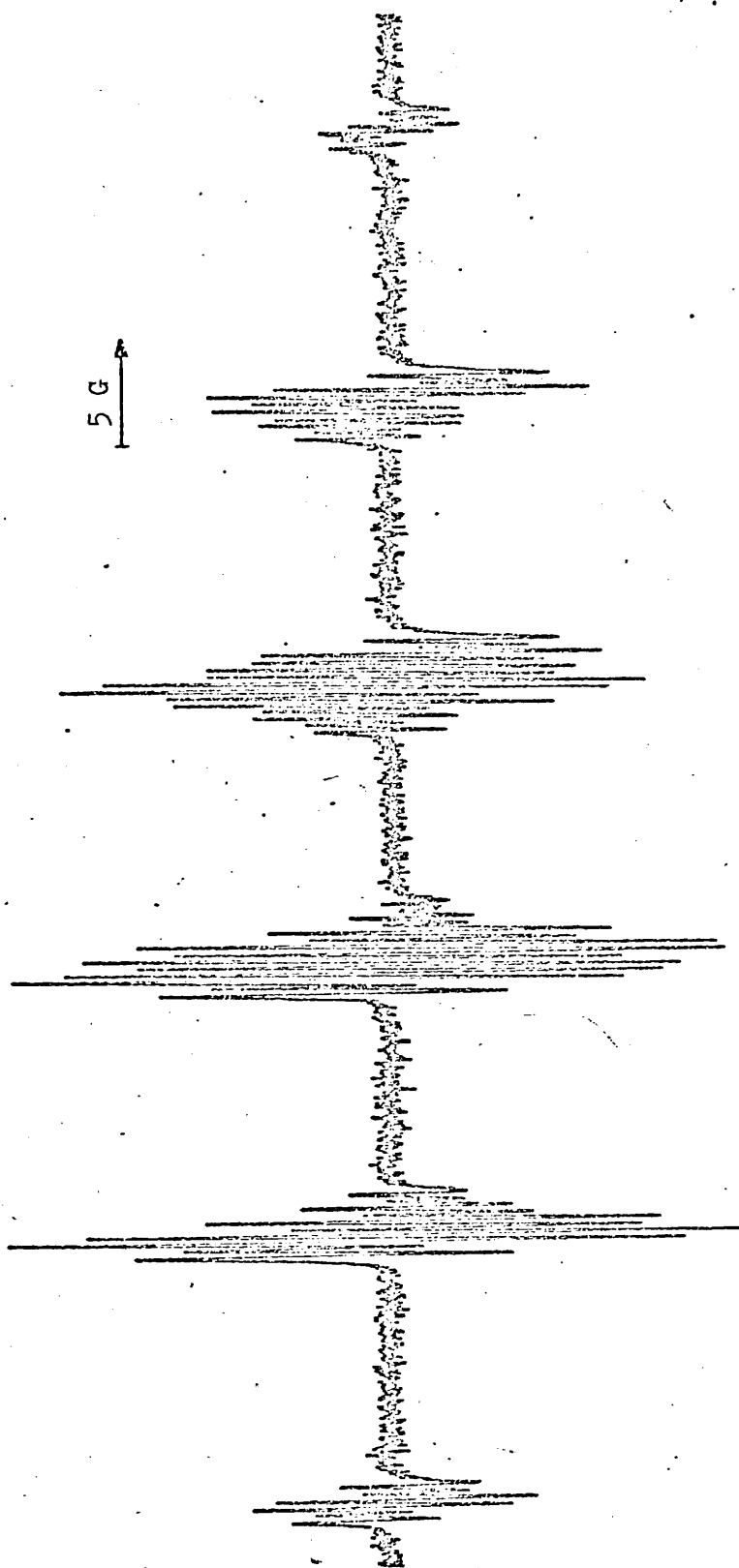

Figure 3.8 ESR spectrum of methyl 2,6-dibromophenyl nitroxide in aqueous DMSO solution.

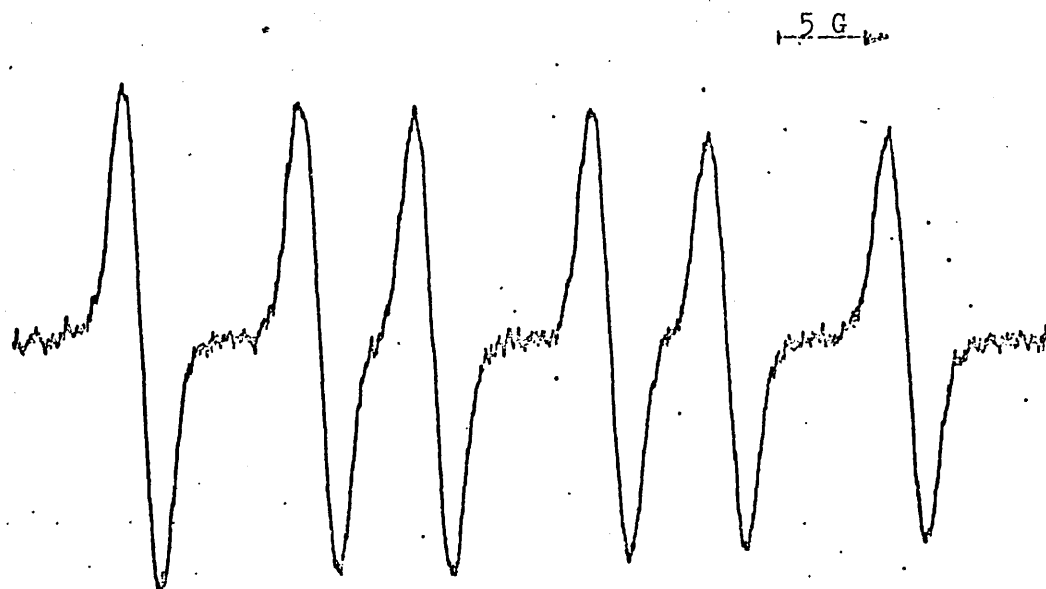

Figure 3.9 ESR spectrum of isopropyl 2,6-dibromophenyl nitroxide in aqueous DMSO.

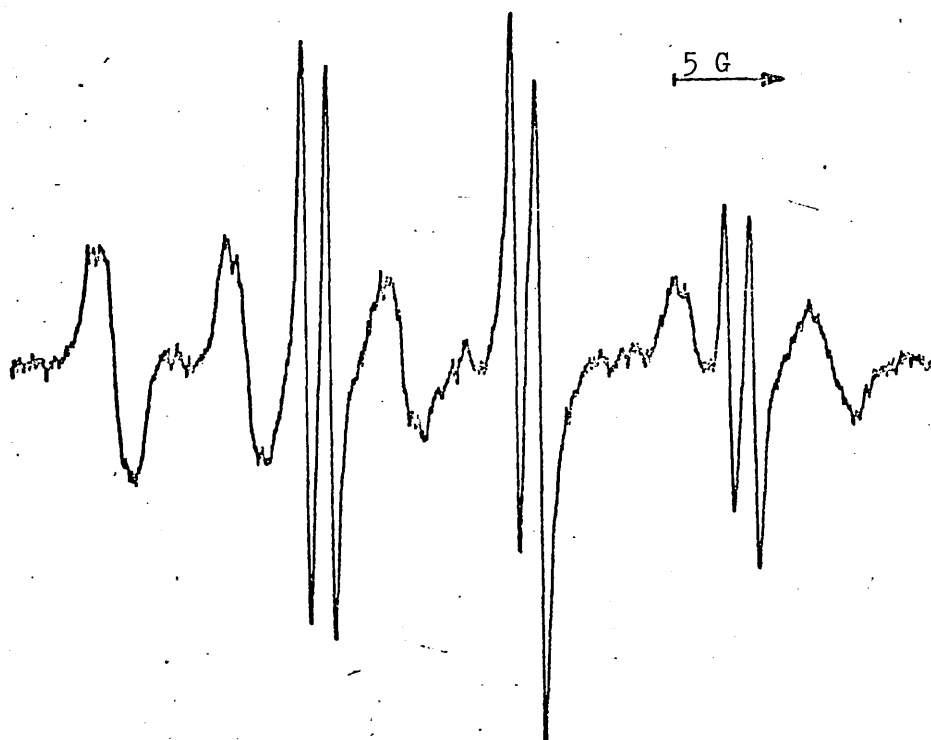

Figure 3.10 ESR spectrum of isopropyl 2,4,6-trichlorophenyl nitroxide (broad lines) and the secondary radical (narrow lines, Section 3.11).

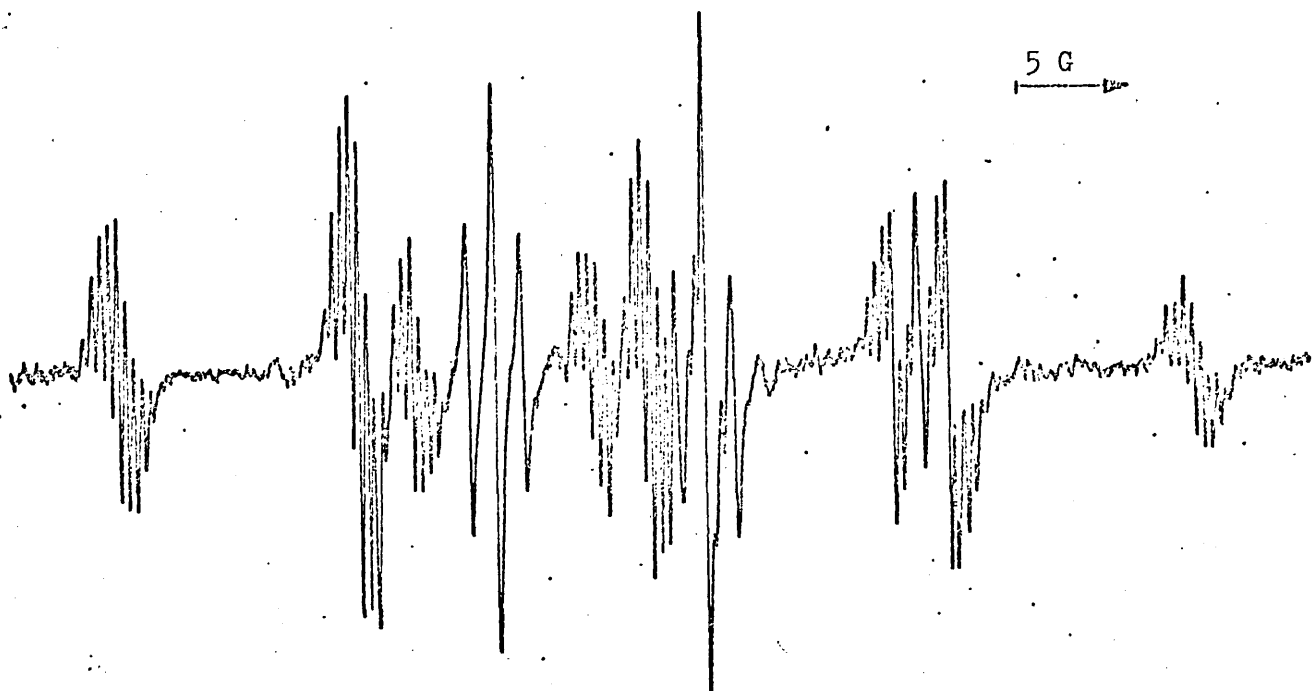

Figure 3.12 ESR spectrum of a mixture of the ethyl 2,6-dichlorophenyl nitroxide and the corresponding secondary radical in alkaline aqueous DMSO solution.

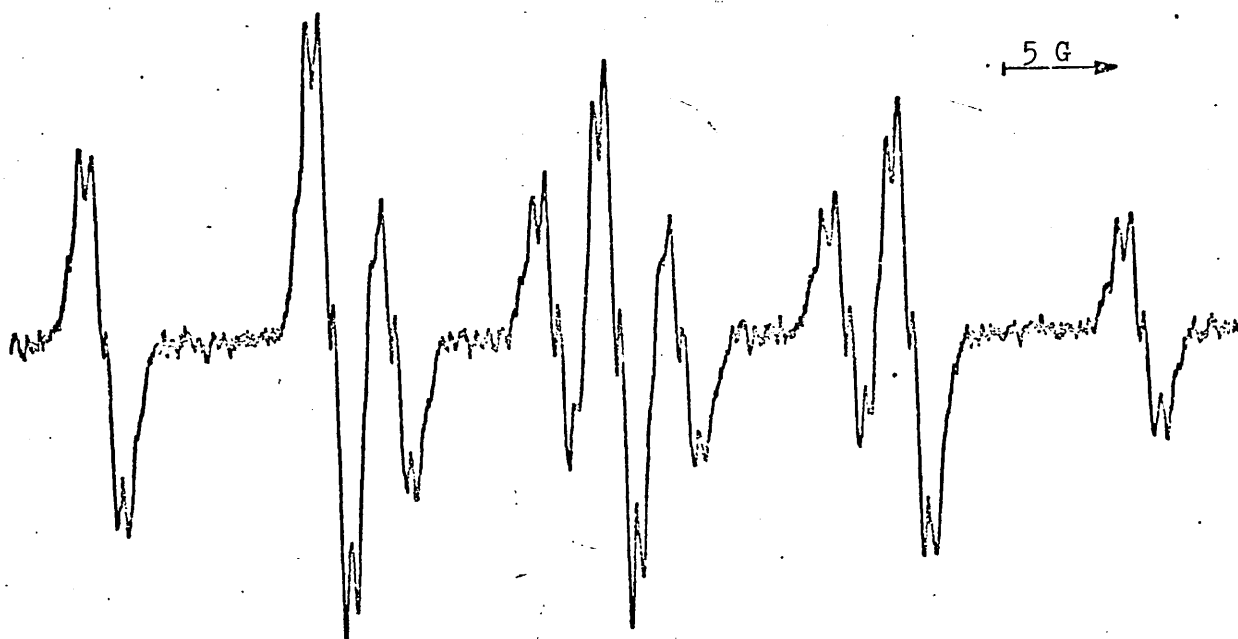

Figure 3.13 ESR spectrum of n-propyl 2,6-dichlorophenyl nitroxide in alkaline aqueous DMSO solution.

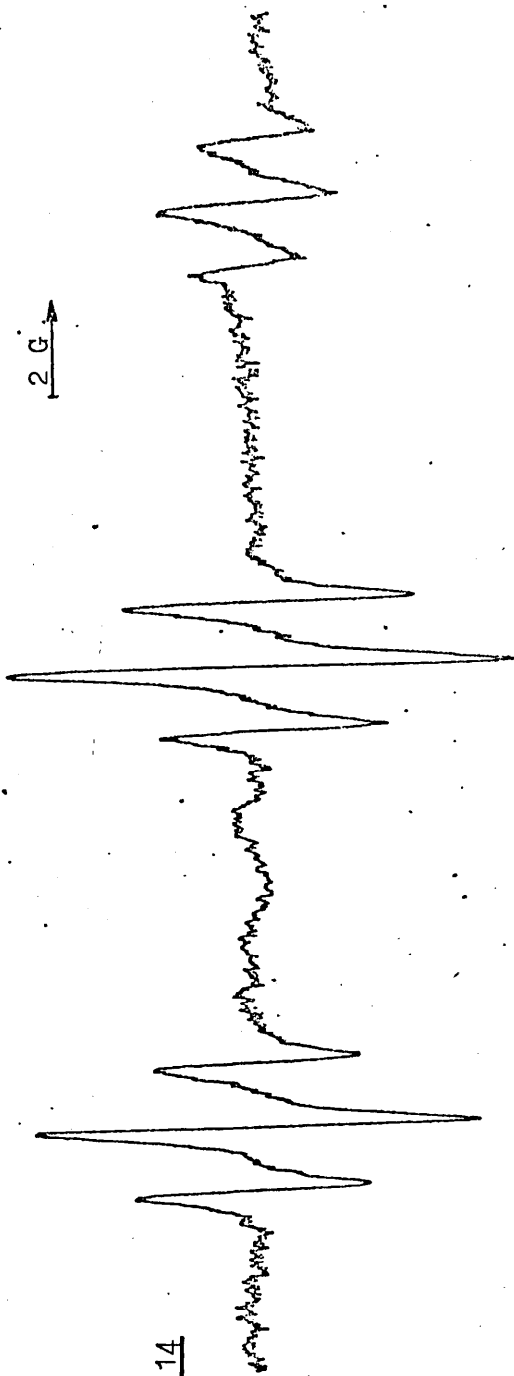

Figure 3.14

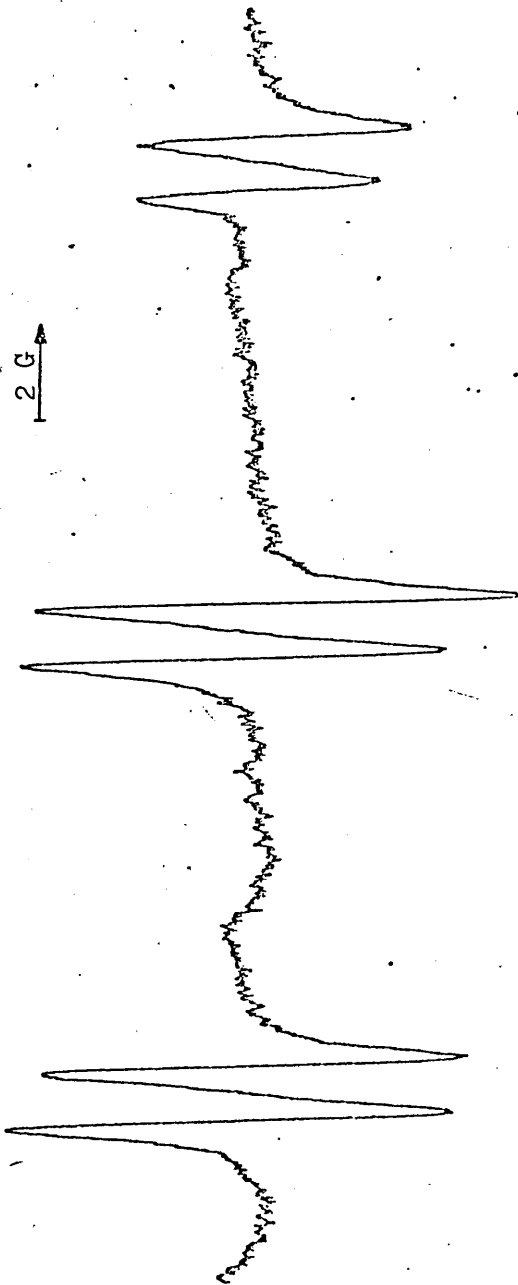

Figure 3.11

Figure 3.14 ESR spectrum of the secondary radical (Section 3.11) detected in the reaction of (IX) with n-propyl iodide in alkaline aqueous DMSO solution.

Figure 3.11 ESR spectrum of the secondary radical detected from the reaction of (VIII) with isopropyl iodide in alkaline aqueous DMSO.

Section 3.2

The Mechanism of Nitroxide Formation in the Reaction of C-Nitroso Compounds with a Base and Alkyl Halide [Reaction (xv)].

Possible mechanisms for the production of the alkyl aryl nitroxides observed in the reaction between an alkyl halide, base and nitrosoarene [Reaction (xv)] are

a) by a substitution reaction involving an anionic or radical-anionic intermediate:

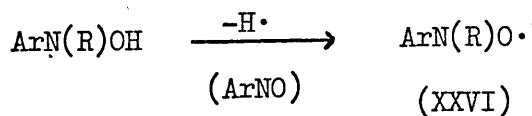
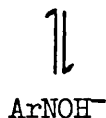
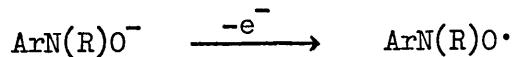
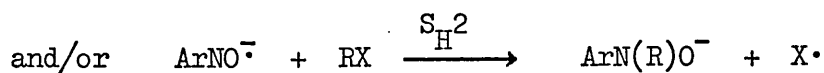
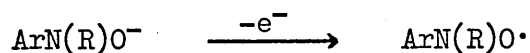
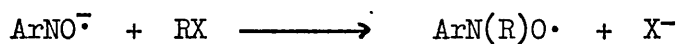



b) by an electron transfer process (cf.  $S_{RN}1$ ):

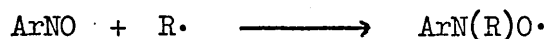
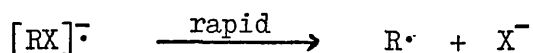
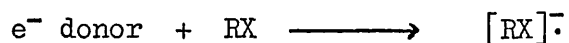

The electron donor would be envisaged as some intermediate from the reaction of the nitroso compound and the base.

A result not consistent with b) was obtained when a nitroxide was not detected (Section 3.1 B) when RX was iodobenzene, yet aryl halides are known to participate in substitution by the  $S_{RN}1$  mechanism.<sup>38</sup> A nitroxide would not be expected with aryl halides if route a), involving nucleophilic or homolytic substitution, were involved, because of the difficulty of attack by negatively charge intermediates on non-activated arenes.

Section 3.3

Spin Trapping

In order to distinguish between the two types of mechanism outlined the possible intermediacy of alkyl radicals was investigated. 2-Methyl-2-nitrosopropane ('nitrosobutane') was examined for use as a spin-trap in the reaction.

The reactions between nitrosobutane and potassium t-butoxide or aqueous sodium hydroxide were examined in DMF, DMSO, ethanol or t-butyl alcohol as solvents. In agreement with a previous report<sup>47</sup> (see Section 1.4) di-t-butyl nitroxide, the 2-methyl-2-nitrosopropane radical-anion and the 2-methyl-2-nitropropane radical-anion were detected depending upon the reaction conditions. With DMSO as solvent, t-butyl methyl nitroxide was also observed with either potassium t-butoxide or sodium hydroxide as the base. For this reason DMSO was not used as a solvent for spin trapping experiments. In DMF solution with sodium hydroxide as base, several nitroxides formed from the trapping of solvent derived radicals, in addition to di-t-butyl nitroxide, were found (Figure 3.15):

12.20 G (1N)	assigned <sup>96</sup> to	$\text{Bu}^t\text{N}(\text{O}\cdot)\text{CO}\cdot\text{NMe}_2$
18.65 G (1N)	]	$\text{Bu}^t\text{N}(\text{O}\cdot)\text{NMe}_2$
0.90 G (1N)		
14.75 G (1N)	]	$\text{Bu}^t\text{N}(\text{O}\cdot)\text{CH}_2\text{NMe}\cdot\text{CO}$ <sup>96,97</sup>
2.35 G (1N)		
17.50 G (1H)		

The above results in DMSO and DMF show the presence of a reactive radical in the nitrosobutane - base reaction (Section 3.5). By contrast, in ethanol solution the reaction between nitrosobutane and sodium hydroxide or potassium t-butoxide generated only low concentrations of di-t-butyl nitroxide.

In t-butyl alcohol, sodium hydroxide and potassium t-butoxide both reacted with nitrosobutane to form di-t-butyl nitroxide and a second radical with a large nitrogen splitting (25 to 28.5 G) assigned to either the 2-methyl-2-nitropropane radical-anion or t-butyl t-butoxy nitroxide.

The above series of experiments was repeated with the addition of methyl iodide, chosen in order to minimise the spectral overlap of di-t-butyl nitroxide and the expected alkyl t-butyl nitroxide. The presence of methyl iodide in the reaction of nitrosobutane and base had no effect upon the production of the long-lived radicals, except in two instances. Firstly, when the reaction was performed with DMF as solvent, the concentration of nitroxides generated from the trapping of solvent-derived radicals was reduced (see Section 3.8). Secondly, when ethanol was the solvent, and sodium hydroxide the base, the spectrum attributed to t-butyl methyl nitroxide was observed at low intensity after approximately 30 minutes reaction time. Thus, when in competition with other reaction routes, basic solutions of nitrosobutane react only slowly, or not at all, with methyl iodide to generate a nitroxide.

For the "spin-trapping" experiments the following reaction system was used as a model,

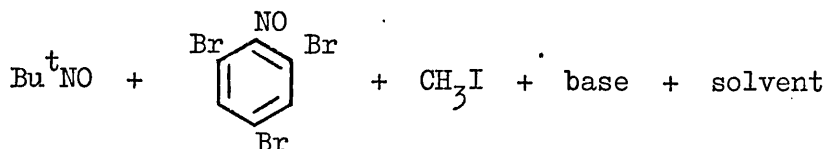

in which the base was sodium hydroxide or potassium t-butoxide and the solvents were t-butyl alcohol, ethanol or DMF. These reagents would cause a minimum of spectral overlap for the radicals expected. For all the combinations of solvent and base, methyl 2,4,6-tribromophenyl nitroxide and di-t-butyl nitroxide were detected in high concentration. In t-butyl alcohol a third radical was detected [ca. 27 G (1N),  $\text{Bu}^t\text{NO}_2^-$  or  $\text{Bu}^t\text{N}(\text{OBu}^t)\text{O}\cdot$ ]. Only in ethanol solution was t-butyl methyl nitroxide detected (Figure 3.16). The spectrum of this radical appeared shortly after transferring the reaction mixture to the spectrometer, and the radical concentration was higher than that observed in the absence of the nitrosoarene. Thus the above results possibly indicate the presence of methyl radicals generated in reaction (xv) in ethanol solution. However further evidence bearing on this is described below.

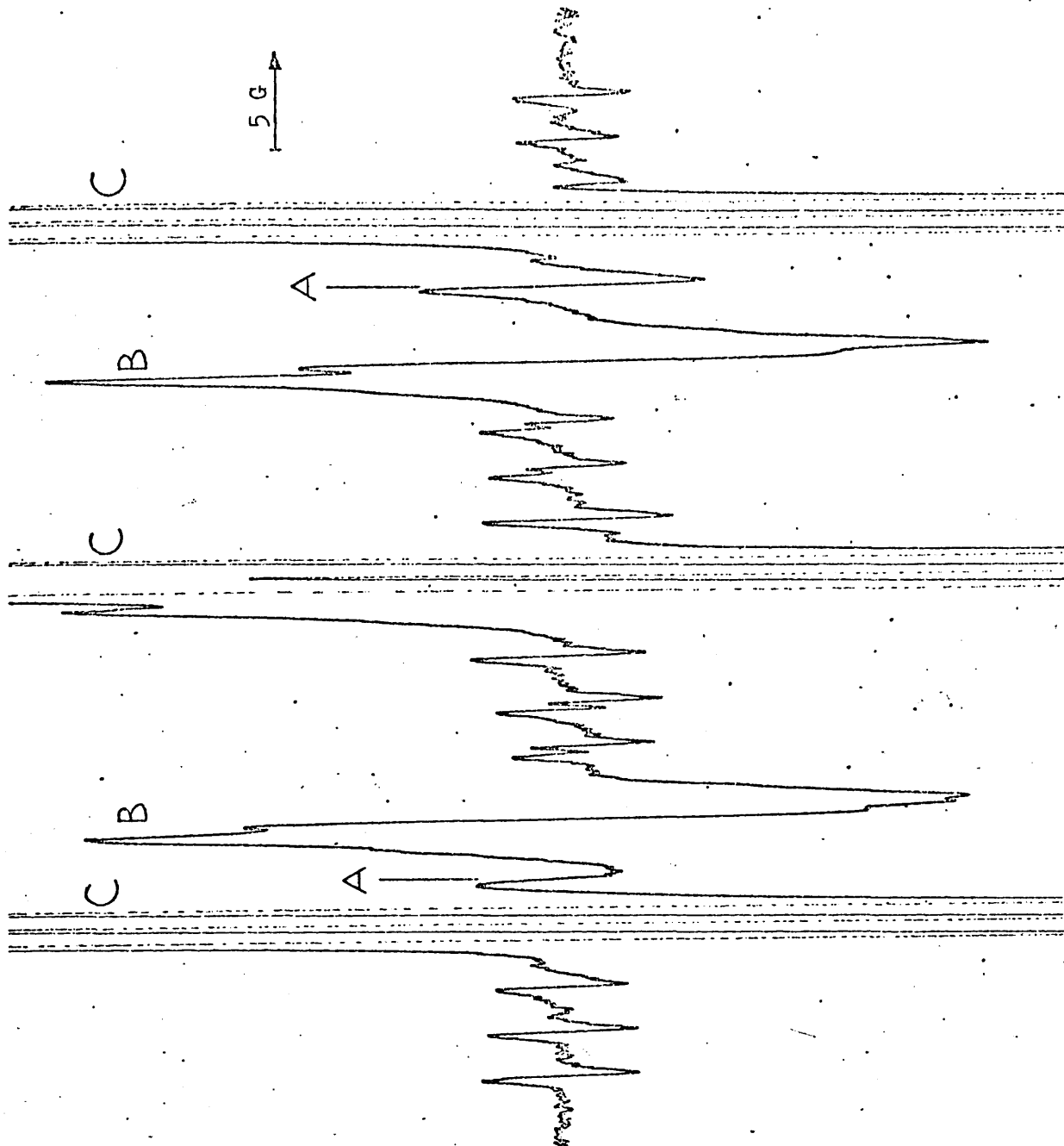

Figure 3.15 ESR spectrum of the mixture of radicals detected from the reaction of aqueous sodium hydroxide with nitrosobutane in DMF.

$\text{Bu}^t_2\text{NO}\cdot$  lines are marked A

$\text{Bu}^t\text{N}(\text{O}\cdot)\text{CO N}(\text{Me})_2$  B

$\text{Bu}^t\text{N}(\text{O}\cdot)\text{N}(\text{Me})_2$  C

The remaining lines are attributed to  $\text{Bu}^t\text{N}(\text{O}\cdot)\text{CH}_2\text{NMeCO}_2\text{H}$ .

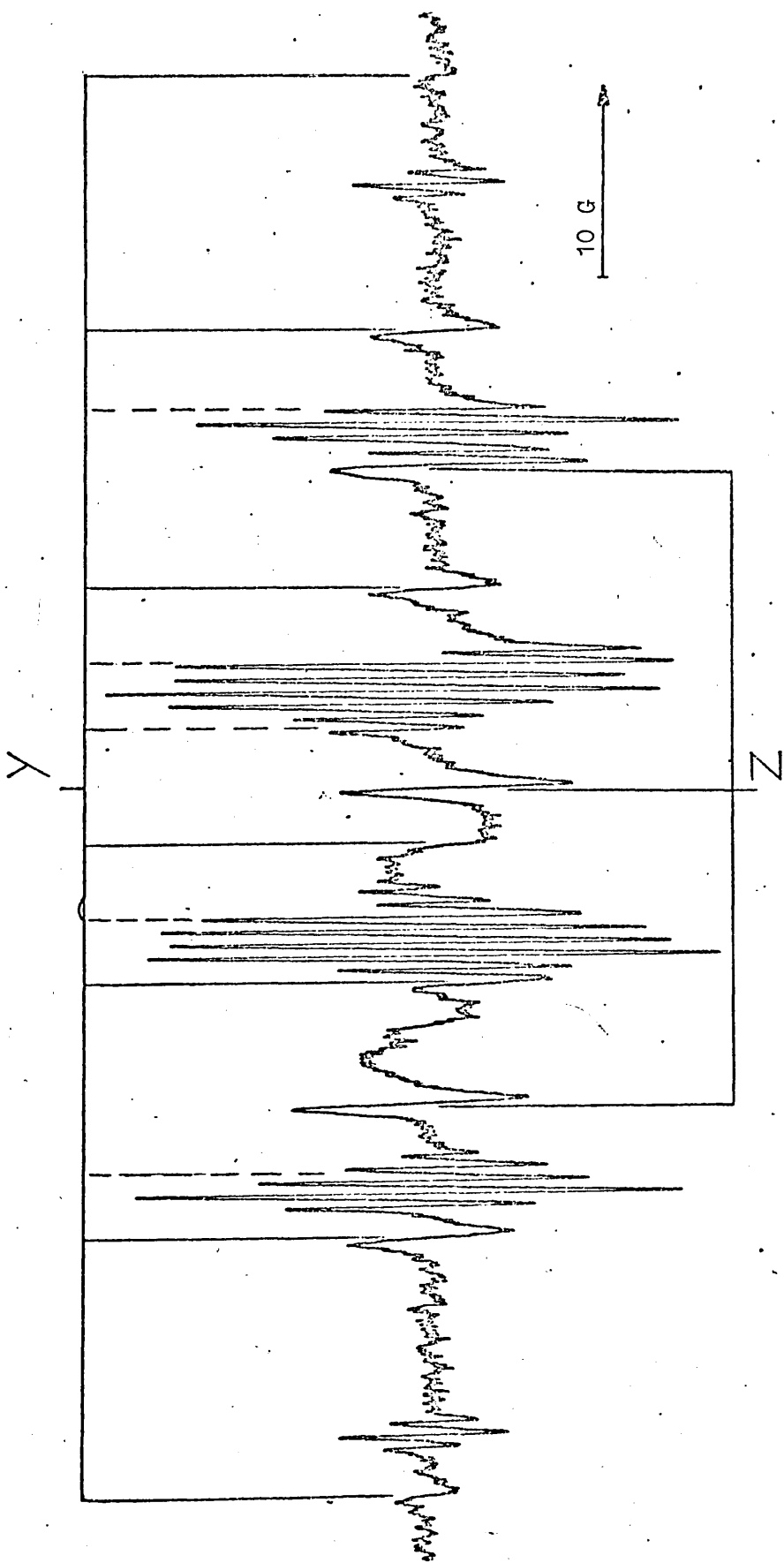

Figure 3.16 ESR spectrum of the nitroxides detected from the reaction of (VI) with methyl iodide and sodium hydroxide in the presence of nitrosobutane in ethanol solution. Lines due to  $\text{Bu}^t\text{N}(\text{O}\cdot)\text{CH}_3$  are marked Y and those due to  $\text{Bu}^t_2\text{NO}\cdot$  are marked Z.

Section 3.4

The Effect of a Nitroarene

p-Bromonitrobenzene (XXVII) was used as a model nitro-compound and the following results were obtained.

When sodium hydroxide was added to nitrosobutane and (XXVII) in ethanol, di-*t*-butyl nitroxide and the radical-anion of (XXVII) were detected, showing that the nitrosobutane-base reaction mixture is capable of reducing (XXVII) (the radical-anion was not observed in the absence of nitrosobutane). If methyl iodide was added to the above reaction solution the radical-anion of (XXVII) was replaced by that of methyl *t*-butyl nitroxide. Furthermore, if methyl iodide was present before the addition of sodium hydroxide, the spectrum of methyl *t*-butyl nitroxide was observed initially and in higher concentration than when the nitro compound was absent.

Thus the presence of (XXVII) promotes the generation of *t*-butyl methyl nitroxide. A similar effect was observed when lead dioxide was added to an ethanol solution of nitrosobutane, methyl iodide and aqueous sodium hydroxide. Lead dioxide is known to be a good one-electron oxidising agent, capable of generating a nitroxide from the corresponding hydroxylamine:<sup>98</sup>

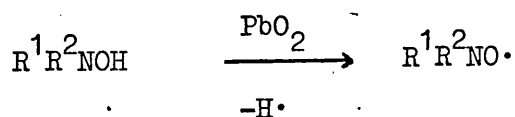

It seems that (XXVII) is capable of accelerating the oxidation and 2,4,6-tribromonitrosobenzene would be expected to accept an electron also. (Half-wave polarographic reduction potentials lie in the order,  $\text{Bu}^t\text{NO}_2 > \text{Bu}^t\text{NO} > \text{ArNO}_2 > \text{ArNO}$  for most Ar groups).

Consequently, the result in Section 3.3 from reaction (xvii) performed in ethanol solution,

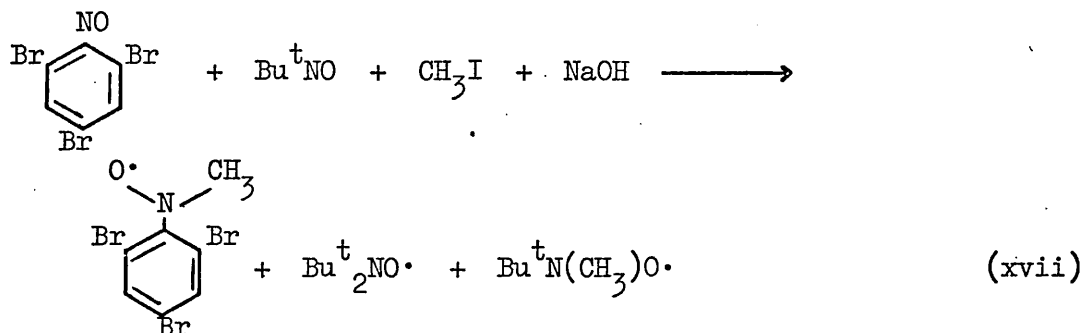

where methyl t-butyl nitroxide was observed in higher concentration than when the nitrosoarene was absent does not indicate the presence of methyl radical, but suggests a change in the equilibrium position of (xviii).

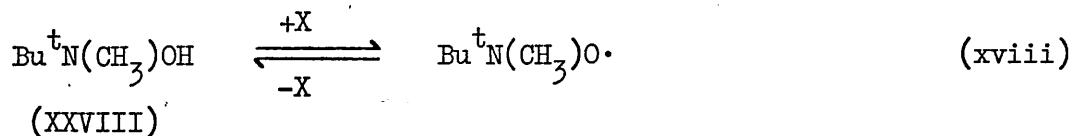

where  $\text{X} = \text{Bu}^t\text{N}(\text{O})=\text{CH}_2$  or  $\text{ArNO}$

(XXVIII) May be formed in reaction (xvii) either by trapping of methyl radicals or from a substitution step involving methyl iodide (cf. routes a) and b) in Section 3.2).



### Section 3.5

#### The Formation of a Reactive Radical in the Reaction of a Base and a C-Nitroso-Compound.

In the previous section it was noted that in the reaction of nitrosobutane with base in DMF or DMSO, nitroxides, which originated from the trapping of solvent derived radicals, were detected.

When 2,4,6-tribromonitrosobenzene was allowed to react with sodium methoxide in DMSO the spectrum of the corresponding aryl methyl nitroxide was detected. Also in the reaction:  $\text{ArNO} + \text{RI} + \text{base in DMSO}$  ( $\text{Ar} = 2,4,6\text{-Cl}_3\text{C}_6\text{H}_2$ ,  $\text{R} = \text{n-propyl}$  and the base was aqueous sodium hydroxide;  $\text{Ar} = 2,4,6\text{-Br}_3\text{C}_6\text{H}_2$ ,  $\text{R} = \text{ethyl}$  and the base was aqueous sodium hydroxide, or potassium t-butoxide in t-butyl alcohol), a similar effect was seen and the appropriate methyl aryl nitroxide was detected in low concentration.

The above results indicate that the hydroxyl radical (or alkoxy radical where appropriate) is generated by the reaction of a nitroso-compound with a base. The hydroxyl radical is known to be a powerful oxidising agent and undergoes rapid  $\text{S}_{\text{H}}2$  reaction with DMSO to generate methyl radicals.<sup>93</sup>

There are two probable routes to hydroxyl radical generation:

- 1) The oxidation of the adduct formed by attack of hydroxide ion on the nitroso-compound:

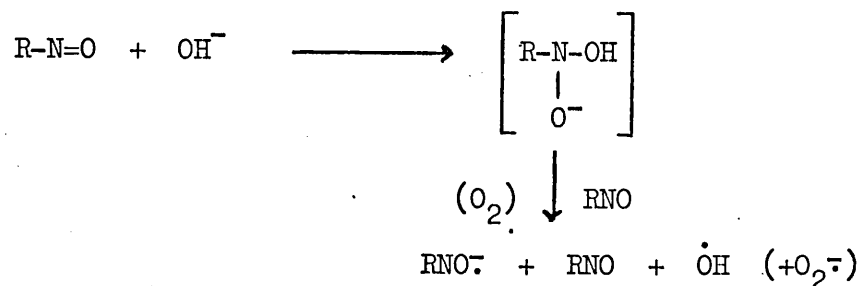

(ii) By reduction of dissolved oxygen:

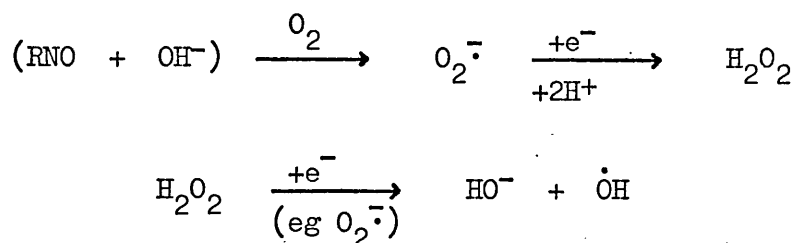

A third possibility exists for nitrosobutane. Electrochemical<sup>99</sup> or sodium<sup>100</sup> reduction of nitrosobutane has been shown to generate the salt (XXIX) from addition of t-butyl radicals to the 2-methyl-2-nitropropane radical-anion.<sup>100</sup>

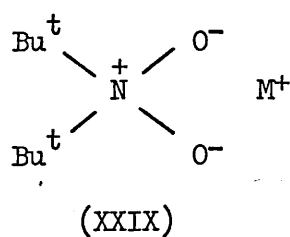

The salt is readily hydrolysed to di-t-butyl nitroxide, hydroxide ion and hydroxyl radical,<sup>100,101</sup>

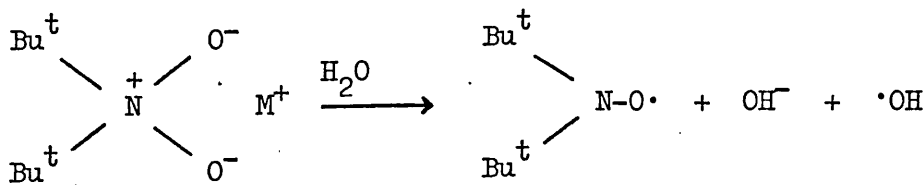





nitrosobutane and hydroxide ion and this was not considered:

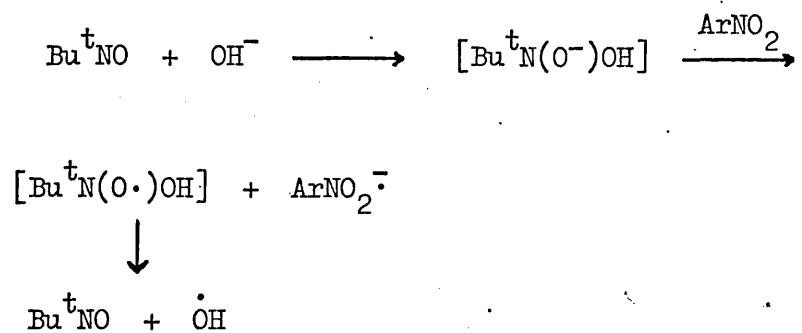

In Section 3.4 the reaction of an aromatic nitro compound with nitrosobutane and sodium hydroxide in for example DMSO, was investigated and the nitro-radical-anion was not detected unless nitrosobutane was present.

Section 3.6

The Use of Electrolysis for C-Nitroso-Radical-Anion Production

Electrolytic methods for radical generation seemed ideal for an investigation of the mechanism of nitroxide formation in the reaction of nitroso-compounds with alkyl halides and base. Long-lived radical-anions may be generated conveniently in the cavity of an e.s.r. spectrometer as shown by Geske and Maki<sup>104</sup> and the polarographic, one-electron, half-wave reduction potential,  $E_{1/2}$  of nitrosobenzene<sup>105</sup> is less than that of an alkyl iodide.<sup>106</sup> Thus conditions could be used where the direct reduction of the alkyl iodide at the cathode was not probable, at the same time generating the nitroso-radical-anion by a "clean" route. It has been shown<sup>105</sup> that  $E_{1/2}$  for nitrosobenzene depends upon the cation present, supplied by the electrolyte. In DMF solution with the ammonium ion or the magnesium II ion  $E_{1/2}$  is ca. -0.3V (v. SCE) and a two-electron process is involved, whereas with tetra-alkylammonium ions or alkali metal ions  $E_{1/2}$  is ca. -0.9 V and a one electron step, is involved. Consequently, a tetra-alkylammonium salt (iodide or perchlorate) was used.

By generating the nitroso-radical-anion electrolytically, the presence of a base is avoided and any short-lived intermediate formed between the base and nitroso-compounds [e.g. (XXXII), (XXXIII) and (XXXIV)], acting as an electron donor, is no longer present.

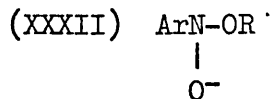

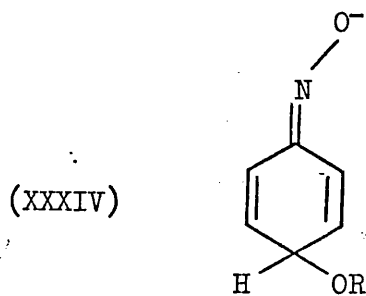
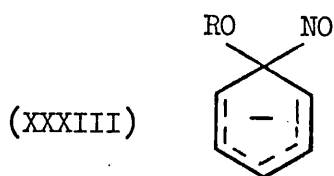

Polargographic and cyclic voltametric studies of the electrochemical reduction of nitrosobenzene in dry dipolar aprotic solvents show that the first reduction step is a reversible one - electron addition, whereas in protic media a reversible two-electron step occurs:<sup>105,106</sup>

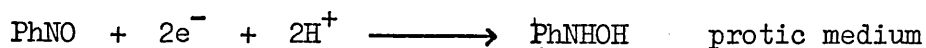
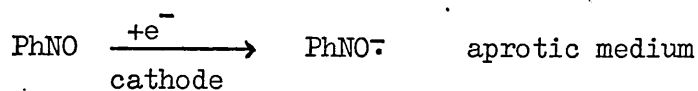

In an aprotic medium a second, reversible, one-electron reduction step occurs at a higher potential, corresponding to dianion formation:<sup>105</sup>

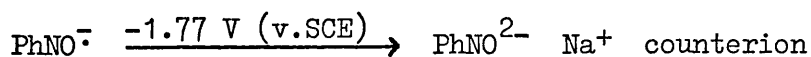
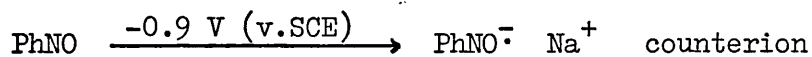

The reduction potential used for nitrosobenzene was ca. -0.8 V (v.SCE) with tetra-n-butylammonium counterion in dry DMSO or DMF. The scheme shown below was therefore, considered improbable.

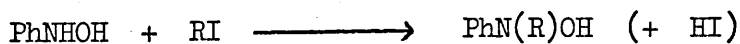
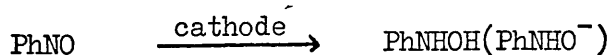

However, although in general radical-anions are kinetically stable in aprotic solvents, because the following equilibrium lies to the left:

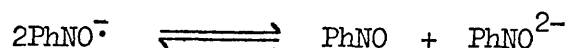

disproportionation will occur if the dianion is consumed (e.g. by reaction with a proton donor). In general, the disproportionation of a radical-anion is less unfavourable if the radical-anion is present as an ion pair or higher aggregate,<sup>51</sup> so that polar solvents hinder disproportionation. A consequence of the above equilibrium is that it is not safe to assume that a reaction of a radical-anion does not proceed through the dianion.

Nitrosobenzene and 2,4,6-trichloronitrosobenzene were used as model aromatic nitroso-compounds for the electrolytic experiments. The e.s.r. spectrum of the nitrosobenzene radical-anion appeared about five minutes after the mercury cathode had been maintained at ca. -0.8 V (v. SCE). In the presence of molecular oxygen, the nitrosobenzene radical-anion appeared in increasing amount after the nitrosobenzene radical-anion was detected. Under nitrogen, when methyl iodide was also present, only the spectrum of methyl phenyl nitroxide was observed, at the same reduction potential. Similar results were obtained with 2,4,6-trichloronitrosobenzene (Figure 3.17). The corresponding nitroxide was also observed from the reduction of 2,4,6-trichloronitrosobenzene in the presence of ethyl, isopropyl and n-propyl iodides, but in none of these experiments was second long-lived radical observed as in the



reaction in the presence of a base. (Section 3.11).

Therefore the appropriate alkyl aryl nitroxide was formed in the absence of oxygen at the potential required for nitroso-radical-anion formation, so that neither the nitro-compound, its radical-anion, nor superoxide ( $O_2^{\cdot-}$ ) is required (see Section 3.7).

The spin trapping and electrolytic experiments show that the nitroso-radical-anion, or possibly the dianion, is the reactive intermediate for nitroxide formation and that an electron-transfer step generating free alkyl radicals is not involved in Reaction (xv) ( $ArNO + RI + base$ ,  $Ar = Ph; 2,6-Cl_2C_6H_3; 2,4,6-Cl_3C_6H_2; 2,6-Br_2C_6H_3$  and  $2,4,6-Br_3C_6H_2$  and  $R = Me, Et, Pr^i, Pr^n$ ).

These conclusions are confirmed by a study<sup>107</sup> of electron-transfer reactions between an electrolytically generated radical-anion ( $A^{\cdot-}$ ) and a less readily reducible compound (BX) forming an unstable radical-anion, by means of polarography. The rate of reduction of BX by  $A^{\cdot-}$ , measured by the catalytic increase in wave-height of A, was seen to be dependent upon the difference in the reduction potentials ( $\Delta E_{1/2}$ ) of A and BX. It was shown that the logarithm of the rate constant<sup>108</sup> ( $k$ ), varied linearly with a negative gradient against  $\Delta E_{1/2}$ . A similar dependence of  $k$  on  $\Delta E_{1/2}$  was expected regardless of whether (xxi) or (xxii) was the rate controlling step.

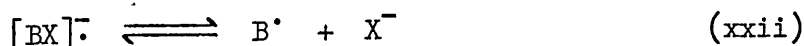
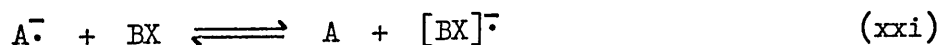

Their results suggest that for the ( $\text{ArNO}^- + \text{RI}$ ) reaction where  $\Delta E_{1/2}$  is ca.  $\geq 0.8\text{V}$ <sup>105,109</sup> (for Ar = Ph; 2,6- $\text{X}_2\text{C}_6\text{H}_3$ ; 2,4,6- $\text{X}_3\text{C}_6\text{H}_2$ , X = Cl or Br and R = Me; Et; i-Pr) a value of ca.  $10^{-4}$ - $10^{-6}\text{lmol}^{-1}\text{s}^{-1}$  for the rate constant would result. In the reaction of superoxide ( $\text{O}_2^-$ ) with an alkyl bromide where  $\Delta E_{1/2}$  is ca. 1.2 V,<sup>71,109</sup> a  $\text{S}_{\text{N}}2$  mechanism with almost complete inversion of configuration operates.<sup>53</sup> Thus for the reaction of a nitroso-radical-anion with an alkyl iodide a direct electron transfer mechanism is not expected to compete with substitution.

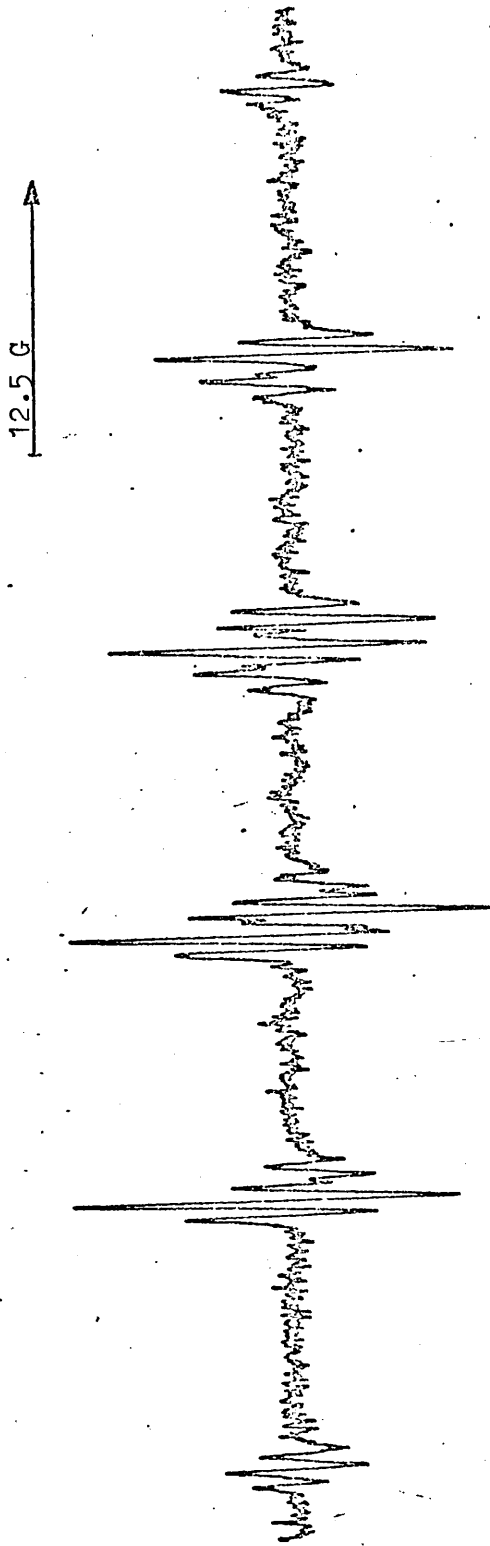

Figure 3.17 ESR spectrum of methyl 2,4,6-trichlorophenyl nitroxide obtained from the electrolytic reduction of (VIII) at a mercury cathode in the presence of methyl iodide in DMSO solution with  $\text{Bu}_4\text{NI}$  electrolyte.

Section 3.7

The Reaction between a Nitroarene Radical-Anion and an Alkyl Iodide.

This reaction was investigated, using e.s.r. as a possible route for nitroxide formation in Reaction (xv). In the presence of oxygen, nitrobenzene is expected to be the major product in the reaction of nitrosobenzene and a base, and the e.s.r. spectrum of the nitro-radical-anion has been detected in the reaction (see Section 1.4). The reaction of alkyl halides with nitro-radical-anions has been investigated only kinetically,<sup>110</sup> and the results were consistent with alkyl radical formation.

Nitro-radical-anions were readily generated from the nitroarene by the action of alkaline aqueous sodium dithionite in DMSO or DMF.

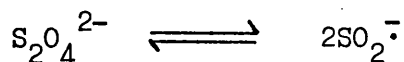

(Ar = p-BrC<sub>6</sub>H<sub>4</sub>; 2,4,6-Bu<sup>t</sup><sub>3</sub>C<sub>6</sub>H<sub>2</sub>; Ph)

When methyl iodide was present in the above reaction the nitro-radical-anion was not detected. When it was added to reaction mixtures this signal decayed rapidly. The effects of ethyl and isopropyl iodides were similar to that of methyl iodide, but the radical-anion decay was less rapid. In the presence of oxygen the radical-anion is in equilibrium with superoxide ion,<sup>72</sup> which reacts rapidly with alkyl

halides.<sup>53,54</sup> The reactions were, therefore, repeated in the absence of oxygen, to determine whether the displacement of the equilibrium below was the reason for decay of the nitro-radical-anion signal:

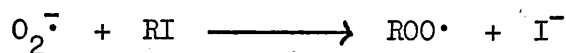
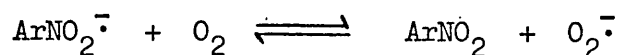

In fact, in the absence of oxygen the same effect was detected, showing that the above scheme does not account for the observations.

When methyl iodide was added dropwise to solutions of the nitrobenzene radical-anion, in the absence of oxygen, a weak e.s.r. signal replaced that of the nitro-radical-anion (Figure 3.18). The spectrum is tentatively assigned to methyl phenyl nitroxide and its formation may be rationalised by either a substitution or an electron transfer process.

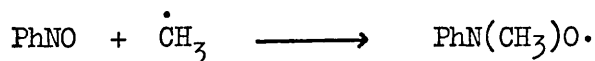
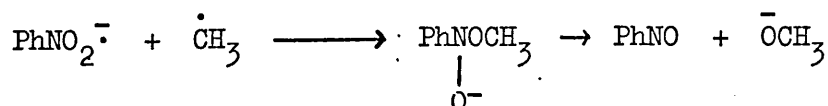
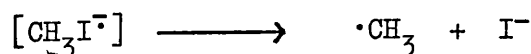
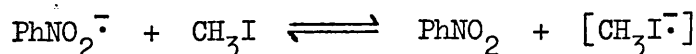

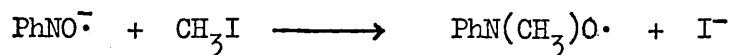
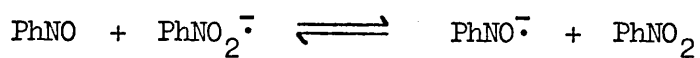
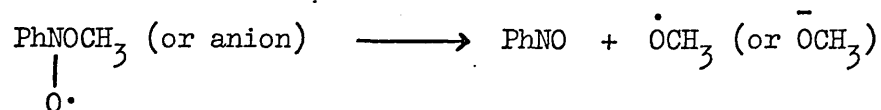
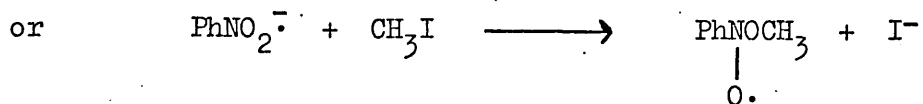

Reduction of nitrobenzene by electrolysis, in the absence of oxygen, produced high concentrations of the radical-anion; however, in the presence of methyl iodide under the same conditions a radical was not observed.

Thus the nitro-radical-anion, when present, may contribute to formation of the alkyl aryl nitroxide in the reaction of the corresponding nitroso-compound with an alkyl iodide in the presence of a base.

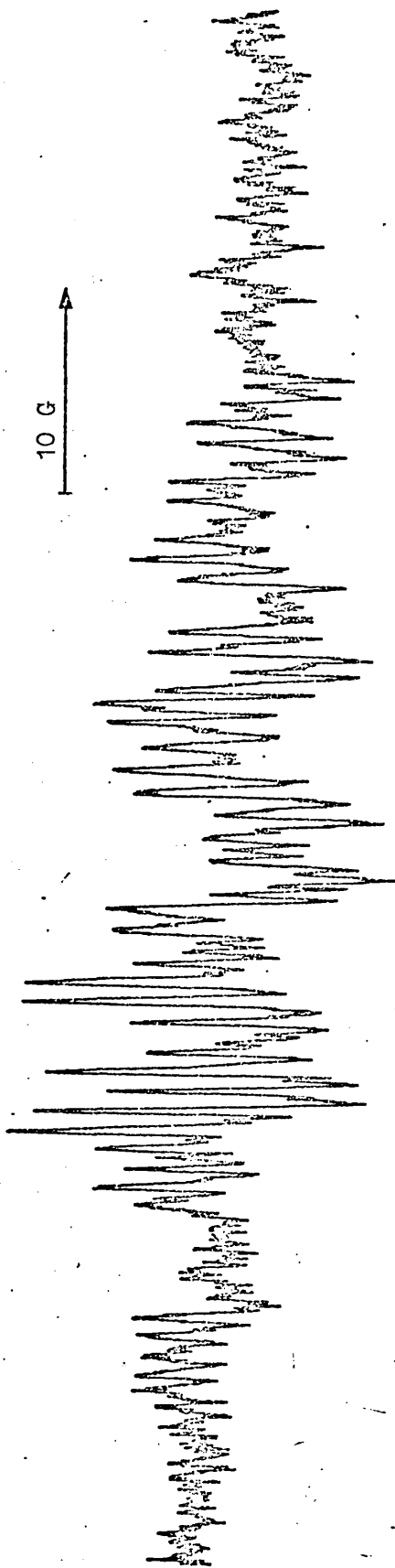

Figure 3.18 ESR spectrum of a nitroxide detected when methyl iodide was added to the nitrobenzene radical-anion in aqueous DMSO solution.

### Section 3.8

#### An E.S.R. Investigation of the Reaction of 2-Methyl-2-nitrosopropane with an Alkyl Iodide and Base.

2-Methyl-2-nitrosopropane (nitrosobutane') was reduced electrolytically in the presence of methyl, ethyl or isopropyl iodide in DMSO solution. In the absence of an alkyl iodide the nitroso-radical-anion ( $a_N = 11.75$  G) and di-t-butyl nitroxide were observed. With ethyl or isopropyl iodide (Figure 3.19) the corresponding alkyl t-butyl nitroxide was detected. However, when nitrosobutane was reduced in the presence of methyl iodide only di-t-butyl nitroxide was observed. This would be expected from the relative stabilities of the nitroxides formed<sup>111</sup> ( $\text{Me} < \text{Et} < \text{Pr}^i < \text{Bu}^t$ ); the steady state concentration of methyl t-butyl nitroxide being too low to detect.

DMSO was not used as a solvent for the reaction of nitrosobutane with an alkyl iodide and base since methyl t-butyl nitroxide was observed in the absence of the alkyl iodide (Section 3.3). Instead, nitrosobutane was allowed to react with methyl, ethyl or isopropyl iodide and sodium hydroxide in DMF solution. The reaction did not lead to the observation of any dialkyl nitroxides (nor any t-butyl nitroxides formed from the trapping of solvent derived radicals, see Section 3.3), whereas in ethanol solution the appropriate alkyl t-butyl nitroxide was detected. Thus in the dipolar-aprotic solvent DMF, nitroxide formation is not competitive with hydroxide attack on the alkyl halide, whereas in the more strongly solvating hydroxylic medium this reaction is slower. In agreement with the electrolysis results, the steady state concentrations of the alkyl t-butyl nitroxides were in the order



$\text{Pr}^i > \text{Et} > \text{Me}$ . Methyl t-butyl nitroxide was not observed unless an oxidising agent (lead dioxide or a nitrobenzene derivative) was present; it is generated, but disproportionates rapidly to the hydroxylamine and methylene nitrene. The oxidising agent alters the hydroxylamine-nitroxide equilibrium in favour of the nitroxide.

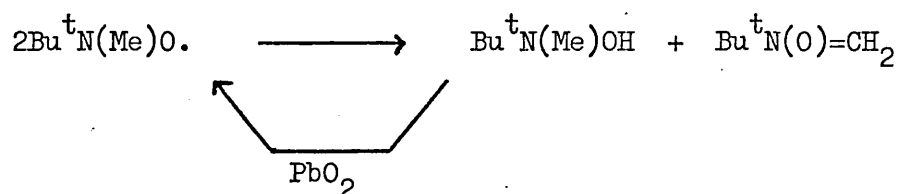

Although the electrolytic reductions were performed at the lowest potential required for observation of the nitrosobutane radical-anion, the polarographic half-wave reduction potentials for nitrosobutane and the alkyl iodides are sufficiently close [difference,  $(\Delta E)$  ca. 0.4 V] that an electron-transfer mechanism, is not excluded (Section 3.6)<sup>107</sup>. For  $\Delta E$  ca. 0.4 V the corresponding rate constant ( $k$ ) is <sup>107</sup> ca.  $10 \text{ l mol}^{-1} \text{ s}^{-1}$  however, when  $\Delta E$  was large (ca. 0.4 V) the error in determining  $k$  increased up to ca. 30%.<sup>107</sup>

Table 3.2

E.S.R. Spectral Parameters of the Nitroxides  $\text{Bu}^t\text{N}(\text{R})\text{O}$ . observed from the reaction:  $\text{Bu}^t\text{NO} + \text{RI} + \text{base (or cathode)}$  in DMSO.

R	$a_{\text{N}}$ (1N) $\pm 0.05$ G	$a_{\text{H}}$ (alkyl) $\pm 0.05$ G
$\text{CH}_3$	16.5	13.25 (3H)
$\text{CH}_2\text{CH}_3$	15.75	11.40 (2H)
$\text{CH}(\text{CH}_3)_2^*$	15.60	1.60 (1H) 0.32 (6H)

\*  $g$ -value = 2.0058

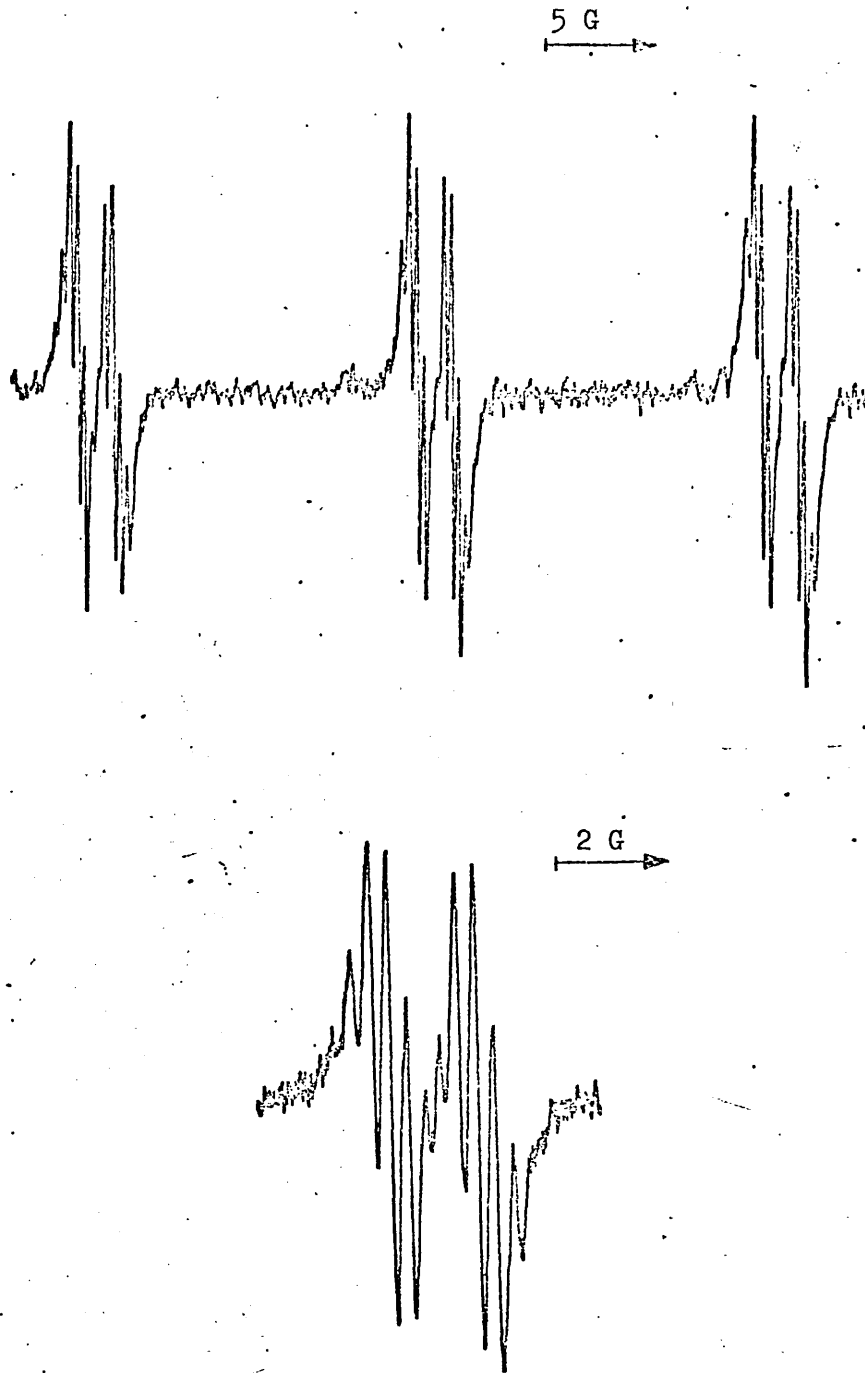
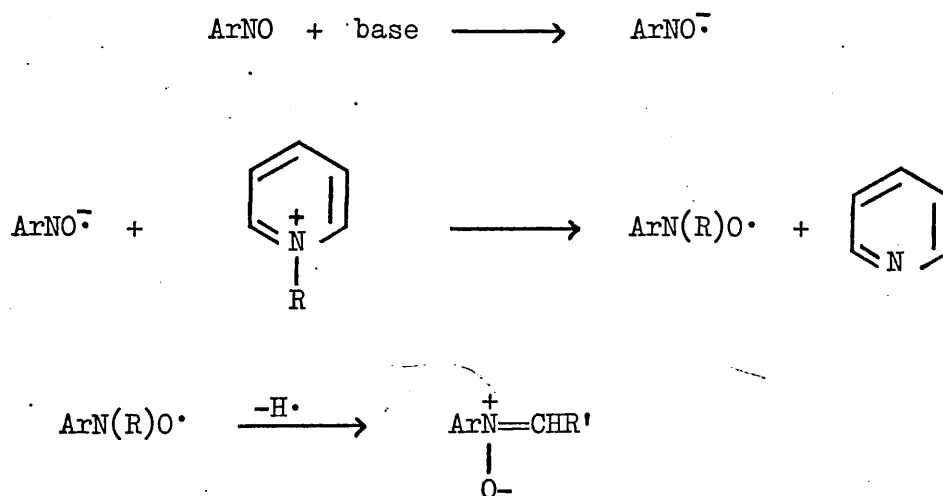

Figure 3.19 ESR spectrum of isopropyl t-butyl nitroxide detected from the electrolytic reduction of nitrosobutane in the presence of isopropyl iodide in DMSO solution. The  $M_N=0$  lines are shown on an expanded scale.

Section 3.9

The Krönke Reaction

In the Krönke reaction, where a nitrosoarene reacts in basic conditions with a pyridinium salt to give a nitrone product (see the Introduction), the results from the reaction of a nitrosoarene, alkyl halide and base is relevant to the mechanism. The nitroso-radical-anion may attack the pyridinium cation to form a nitroxide which would decay to the nitrone:



N-alkylpyridinium iodides were prepared by allowing the alkyl iodide to react with an excess of pyridine in DMSO at room temperature for one hour. 2,4,6-Tribromonitrosobenzene was then dissolved in the resulting solution and aqueous sodium hydroxide added dropwise. With N-methylpyridinium iodide a complex e.s.r. signal was observed [Figure 3.20, 5.70 G (1N), 5.30 G (3H), 4.25 G (1H), 3.10 G (1H), 1.80 G (2H) and 1.10 G (1H)].

The splittings correspond to those expected for a pyridinyl radical.<sup>98,112</sup> Such radicals are long-lived when substituted in the para-position by an electron withdrawing group:<sup>98</sup>

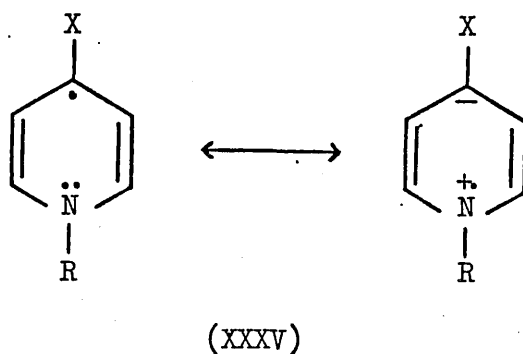

If the para-position is not blocked then reaction with the pyridinium ion occurs to yield a viologen radical-cation (XXXVI):<sup>98,113</sup>

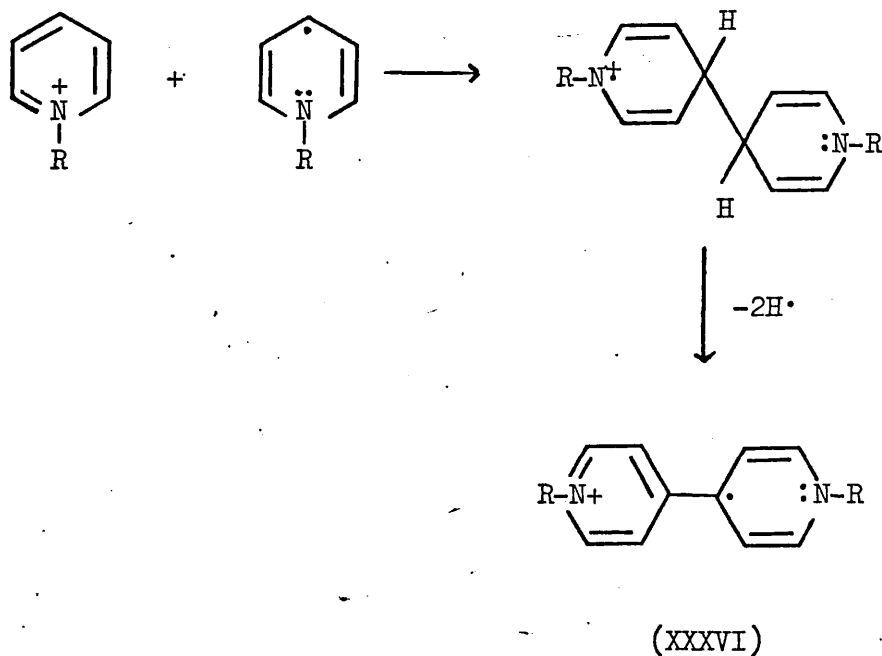

The nitrosoarene was necessary for the observation of the pyridinyl radical as the alkali alone and N-methylpyridinium iodide did not give

a radical product. The action of alkali on N-alkylpyridinium salts gives a 2-pyridone (XXXVII):<sup>114</sup>

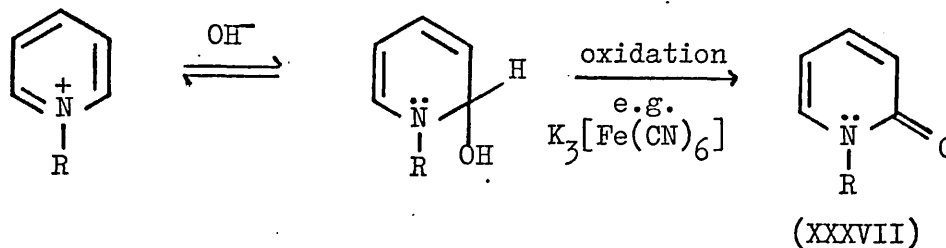

When sodium methoxide was used in place of sodium hydroxide another complex signal was observed, which decayed too rapidly for analysis. Similarly, a pyridinyl radical was observed from the reaction between N-methylpyridinium iodide, nitrosobenzene and sodium hydroxide, which decayed too rapidly for complete analysis (Figure 3.21). Thus it appears that the reactions lead to the formation of a pyridinyl radical, probably of the general formula (XXXV), through substitution into the heterocyclic ring.

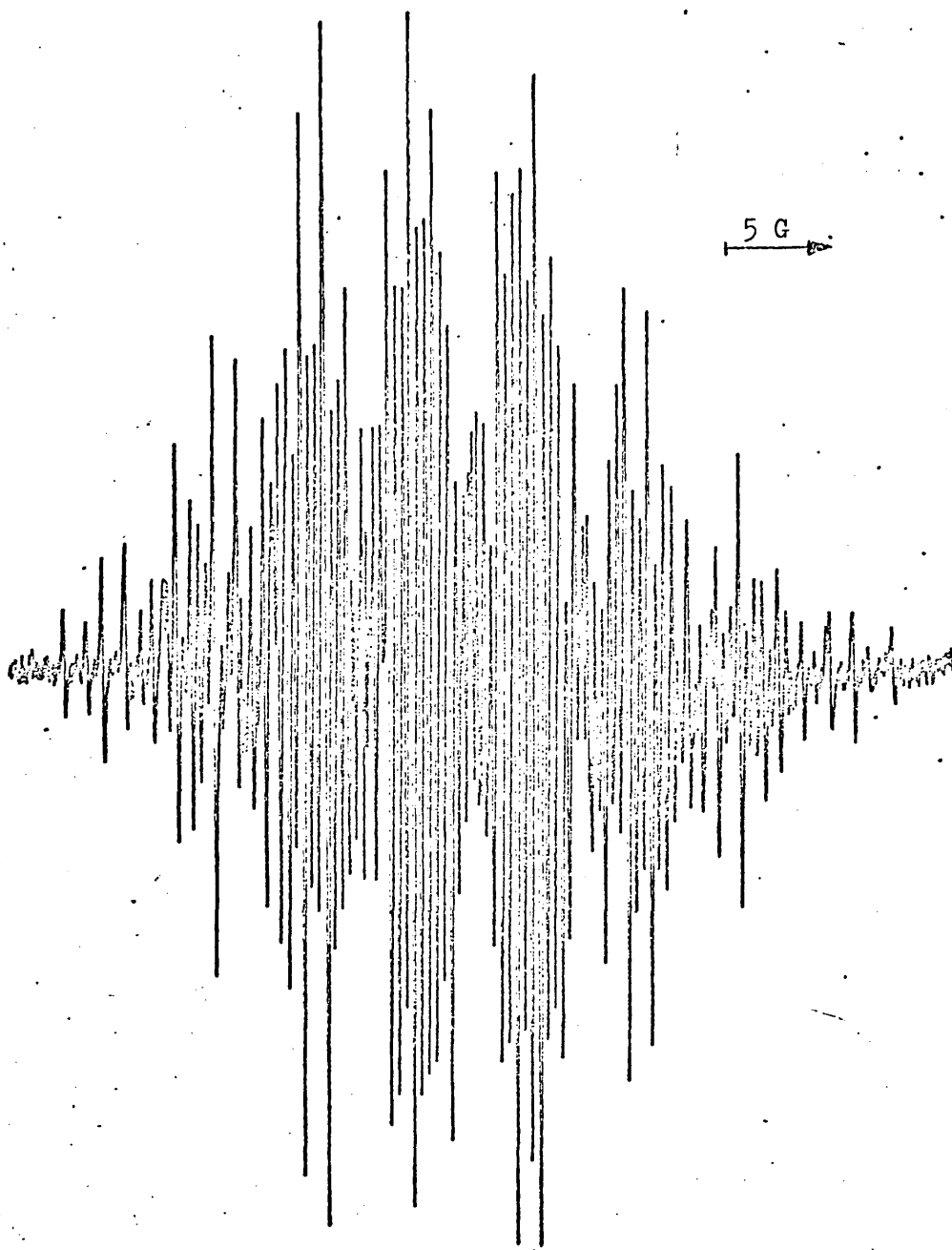

Figure 3.20 ESR spectrum of a pyridinyl radical formed from the reaction of N-methylpyridinium iodide with 2,4,6-tribromonitrosobenzene and sodium hydroxide in aqueous DMSO/pyridine. The low-field part of the spectrum is shown on an expanded scale (overleaf) followed by a computer simulation.

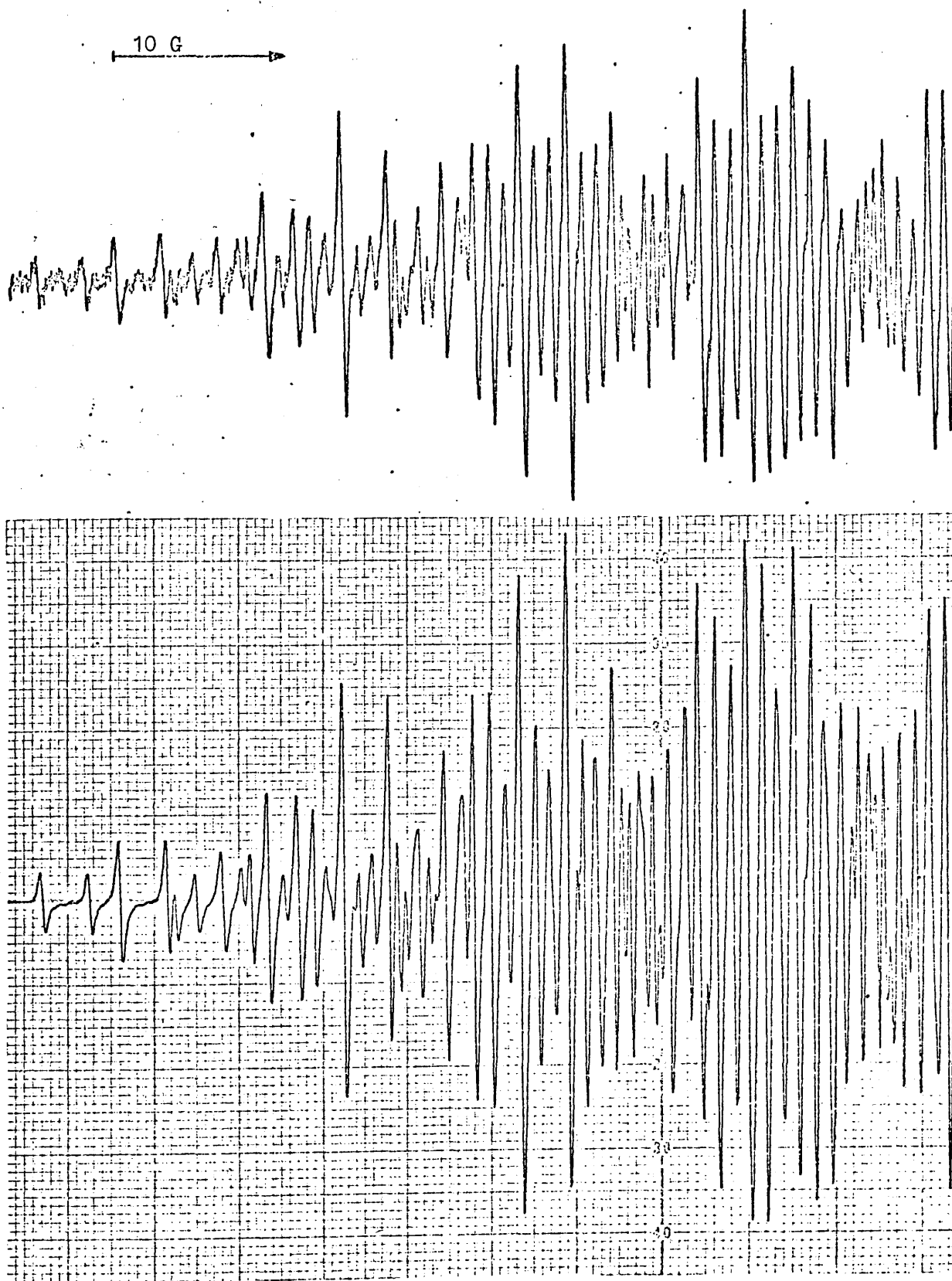

Figure 3.20



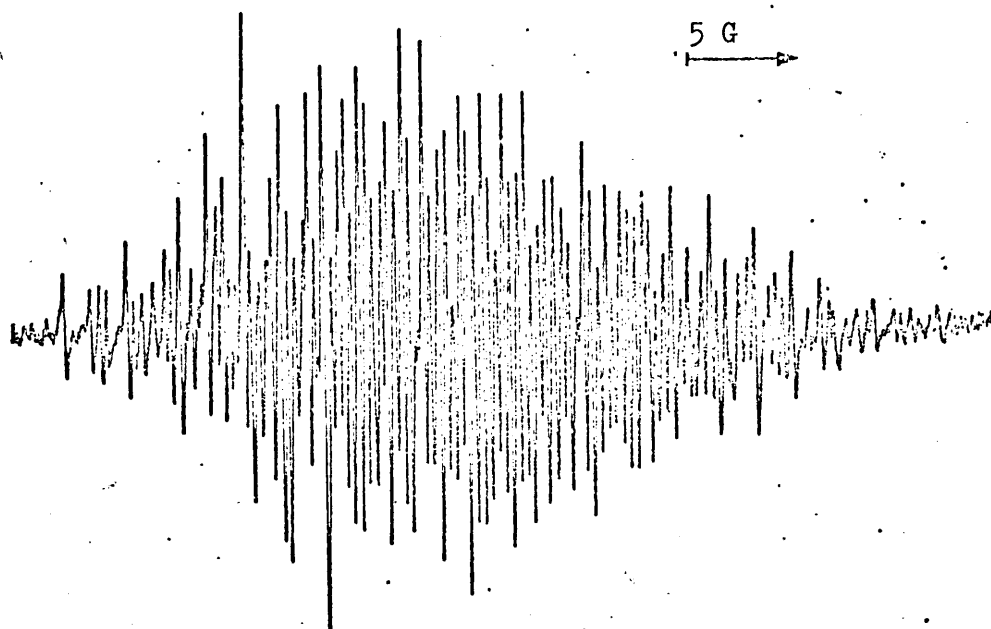

Figure 3.21 ESR spectrum of a pyridinyl radical formed from the reaction of N-methylpyridinium iodide with nitrosobenzene and sodium hydroxide in aqueous DMSO/pyridine.

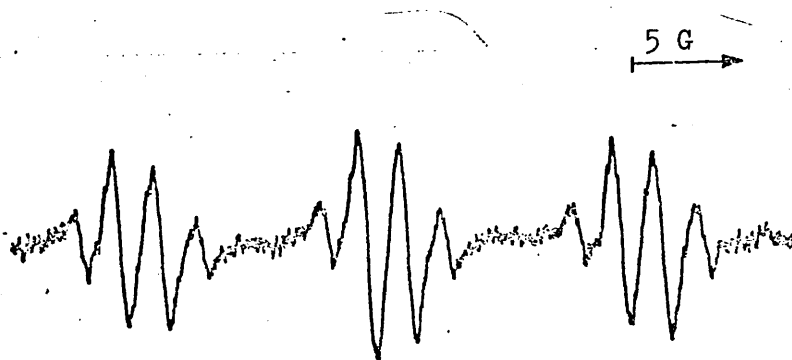
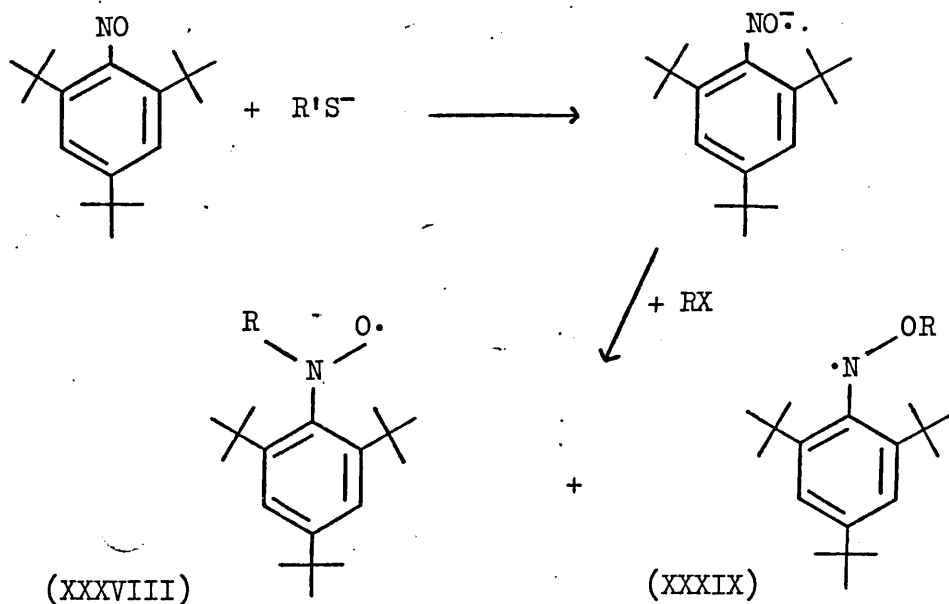

Figure 3.23 ESR spectrum of (XXXIX),  $R = \text{Pr}^i$  detected from the electrolytic reduction of (X) in the presence of isopropyl iodide.

Section 3.10

A Steric Effect in Reaction (xv).

During the course of the work described here, the authors of the report<sup>60</sup> which first led to the investigation undertaken amended their original reaction scheme.<sup>115</sup> Initially they proposed a radical mechanism for the reaction of alkyl halides with mercaptide ions, supported by the detection of nitroxides when a C-nitroso-compound was present in the reaction. This scheme was discarded in favour of direct involvement of the nitroso-compound, reacting via the radical-anion with the alkyl halide to form the nitroxide observed. The main evidence in support of this came from the results with 2,4,6-tri-*t*-butylnitrosobenzene (X), (reducing agents = sodium metal or sodium mercaptides), where the ratio of N-alkylamino radical (XXXIX) to nitroxide (XXXVIII) observed was greater than that for reaction with the corresponding alkyl radical. This was said to show that a substitution reaction, involving a greater steric requirement, led to the radicals observed.



The reaction of sodium with nitrosoarenes in ethereal solution has been shown<sup>116</sup> to produce the radical-anion, the dianion and the dimeric dianion:

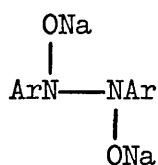

The possibility of reaction via one of these dianions or by direct reduction of the alkyl halide by sodium was not considered:

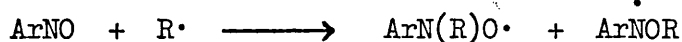

The ease of reduction of nitrosobenzene was overestimated. The reduction potential for an aqueous, pH 7, buffered solution quoted ( $E_{1/2} = 0.10 \text{ V v.SCE}$ )<sup>117</sup> corresponds to a two-electron step generating N-phenylhydroxylamine.

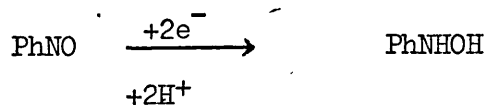

The relevant reduction potential is that for aprotic solvents, a one-electron step to generate the radical-anion ( $E_{1/2} = -0.8 \text{ V v.SCE}$  in DMF with sodium nitrate electrolyte,<sup>106</sup>  $E_{1/2} = -0.9 \text{ V v.SCE}$  in DMF with alkali metal or tetra-alkylammonium cation.<sup>105</sup>). Although figures for

only the oxidation<sup>118</sup> of (X) are available, a value for its reduction potential between -1.0 to -1.5 V v.SCE may be deduced by comparison with the values for the equivalent nitro-compounds. [ $E_{1/2}(\text{PhNO}_2) = -1.1 \text{ V v. SCE}$  in DMF or acetonitrile;  $E_{1/2}(2,4,6\text{-Bu}^t_3\text{C}_6\text{H}_2\text{NO}_2) = -1.5 \text{ V v. SCE}$  in acetonitrile]. Consequently, the radical-anion of (X) may<sup>107</sup> be capable of transferring an electron to an alkyl iodide.

Generation of the radical-anion of (X) by electrolysis should simplify the reaction system and avoid the direct reduction of the alkyl halide. The radical-anion of (X) was readily detected during electrolytic reduction of (X) in DMF solution with tetra-n-butylammonium iodide as supporting electrolyte. Solutions of (X) and an alkyl iodide were reduced at the minimum potential required to generate the nitroso-radical-anion. In the presence of methyl iodide both the anilino radical and the more persistent nitroxide were observed (Figure 3.22). [A similar result was obtained when methyl iodide was added to (X) and potassium t-butoxide in DMSO in the absence of oxygen]. In the previous report only traces of the nitroxide were observed. In the electrolytic reduction of (X) in the presence of ethyl iodide the radicals (XXXVIII) and (XXXIX) (R = Et) were detected in low concentration. In the presence of isopropyl iodide only the anilino radical was observed (Figure 3.23).

Thus similar results were obtained using the electrolytic method as had been obtained by the other workers, and are consistent with a substitution reaction. However, the results do not exclude the possibility of the dianion as the effective nucleophile (Section 3.6):

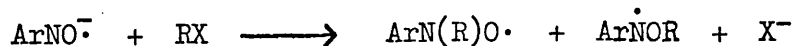

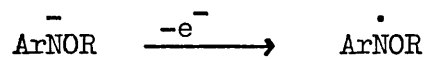
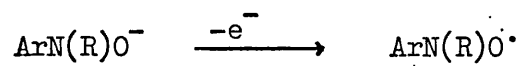
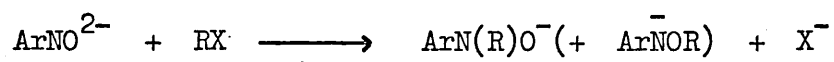
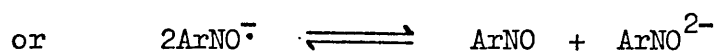

Table 3.3

E.S.R. Spectral Parameters of the Nitroxides,  $2,4,6\text{-Bu}^t_3\text{C}_6\text{H}_2\text{N(R)O}\cdot$  detected from the Reaction, (X) + RI + base (or cathode) in DMSO.

R	Hyperfine Splittings/G		
	$a_N$ (1N)	$\pm 0.05$ G $a_H$ (m-H)	$a_H$ (alkyl)
$\text{CH}_3$	13.20	0.80	12.95 (3H)
$\text{CH}_2\text{CH}_3$	13.75	0.80	18.5 (2H)
$\text{CH}(\text{CH}_3)_2$	Not detected		

Table 3.4

E.S.R. Spectral Parameters of the N-alkoxyanilino radicals 2,4,6-

Bu<sup>t</sup><sub>3</sub>C<sub>6</sub>H<sub>2</sub>NOR detected from the Reaction (X) + RI + base (or cathode)  
in DMSO.

R	Hyperfine splittings/G ± 0.05 G		
	$a_N$ (1N)	$a_H$ (m-H)	$a_H$ (alkyl)
CH <sub>3</sub>	12.20	2.25	2.25 (3H)
CH <sub>2</sub> CH <sub>3</sub>	11.80	2.05	2.05 (2H)
CH(CH <sub>3</sub> ) <sub>2</sub>	11.35	1.75	1.75 (1H)

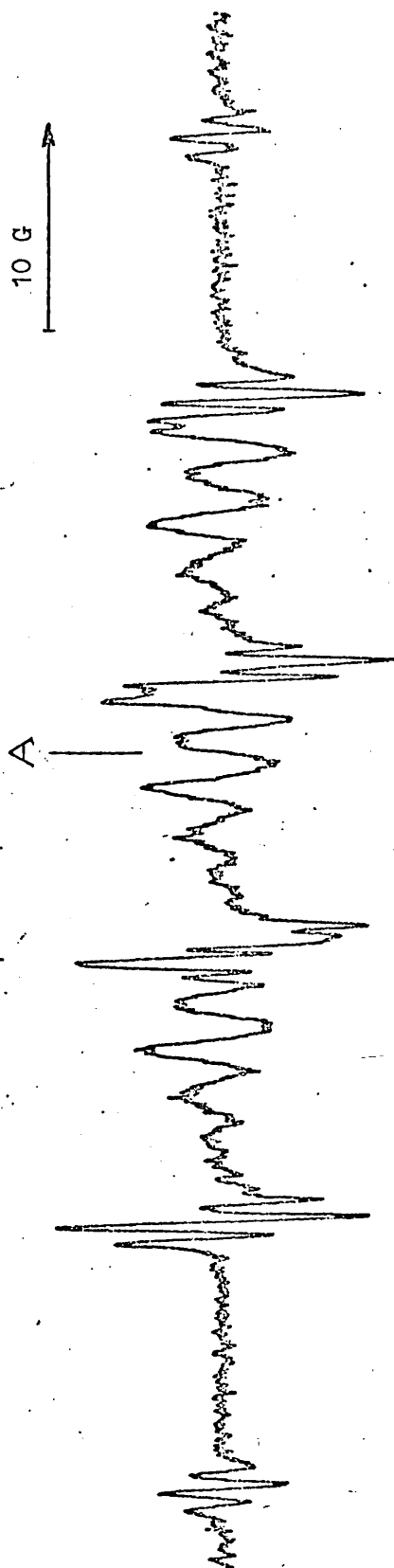

Figure 3.22 ESR spectrum of (XXXVIII) and (XXXIX);  $R = CH_3$  detected, from the electrolytic reduction of (X) in the presence of methyl iodide in DMF solution. The centre of the anilino radical is marked A.



### Section 3.11

#### The Second Type of Persistent Radical detected from Reaction (xv).

As described previously (Section 3.1), a second type of persistent radical (XXV) was often formed in the reactions of alkyl iodides and based with nitrosoarenes having chlorine or bromine at the 2,6- or 2,4,6- positions.

The spectra (Table 3.5) are characterised by a nitrogen splitting of ca. 9.5 G and a (1:2:1) triplet (ca. 1.25 G; ethyl or n-propyl iodide) or a doublet (ca. 1.25 G; isopropyl iodide). The smaller splittings are assigned to the alkyl groups. Although the spectra were observed from solutions of similar composition, small variations in the splitting constants were found (Section 3.1). The nitrogen and alkyl group splittings were seen to increase simultaneously, indicating that the alkyl group is probably situated close to the nitrogen atom and not on the aryl group.

The g-values, ca. 2.0054 (bromo compounds) and ca. 2.0047 (chloro compounds), show the presence of at least one halogen atom in the radicals [cf. the corresponding g-value change on going from the chloro (ca. 2.0062) to the bromo (ca. 2.0065) substituted aryl alkyl nitroxides]. The observation of halogen in the radical indicates the presence of an aryl group, although meta-proton couplings were not detected (linewidth ca. 0.3 G).

The nitrogen and proton splittings and the g-values are all consistent<sup>119</sup> with an N-alkoxyanilino radical structure (ArNOR).

However, the absence of meta- and para-proton couplings does not support this assignment, unless the substitution pattern of the aryl group has changed during the reaction. Nucleophilic substitution by hydroxide into the ring is a possibility, supported by the conditions under which the radicals were detected, they required longer reaction times and higher alkali concentrations than those required for detection of the corresponding nitroxide, and were not detected using the electrochemical or photolytic methods (Sections 3.6 and 3.1).

Hydroxide ion may attack either the ring or the nitroso-group of halogen substituted nitrosoarenes. Attack at the nitroso-group may lead to the breaking of the C-N bond, by analogy with the reaction of hydroxide ion with 2,6-dichlorobenzaldehyde to give 1,3-dichlorobenzene:<sup>120</sup>

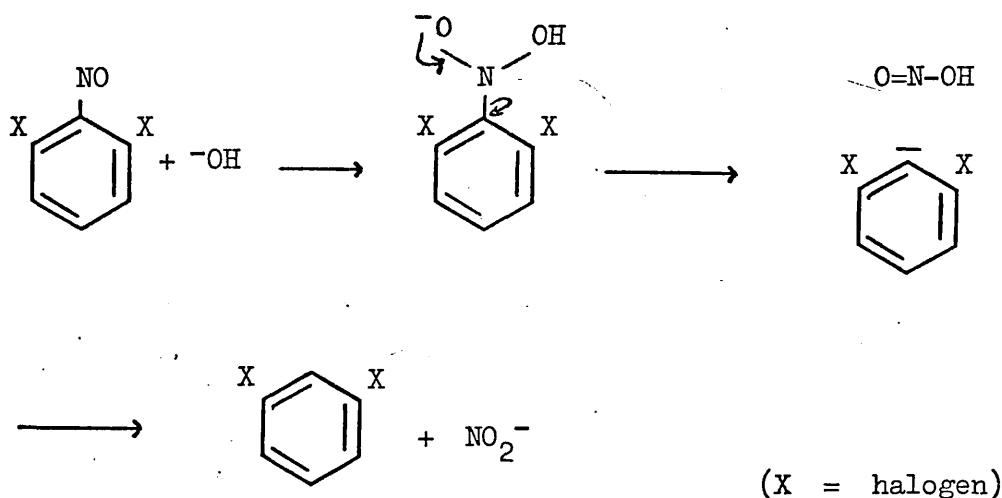

The nitrite ion formed may react with the alkyl iodide and base present to generate radical products. The reaction of sodium nitrite, alkyl iodides and sodium hydroxide in DMSO or DMF gave nitrogen-centred radical products (Section 3.13) but the second type of radical (XXV) was not detected.

Attack of hydroxide ion on the ring of the nitroarene will bring about substitution, favoured by the electron withdrawing substituents present:

For example,

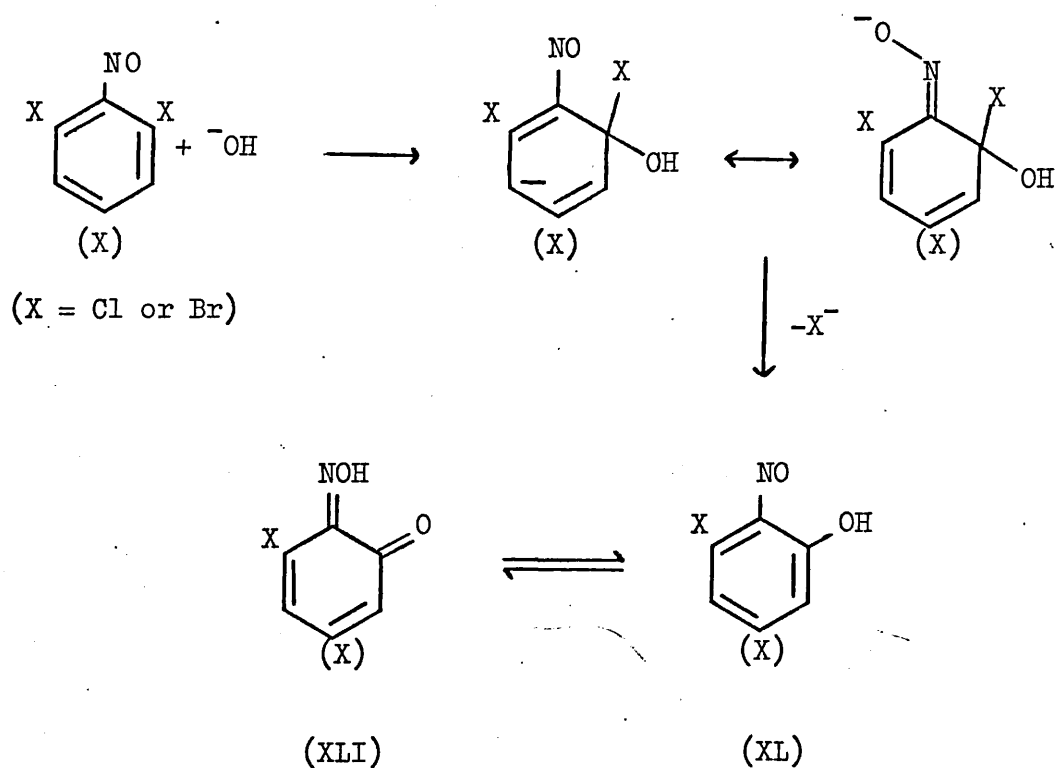

The nitrosophenols formed (XL) exist in a tautomeric equilibrium with the quinone monoxime forms (XLI),<sup>121</sup> via a common anion. In the presence of an alkyl iodide and alkali, alkylation takes place<sup>121</sup> to give (XLII)

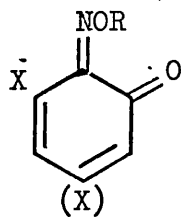

(XLII)

Alternatively, alkylation to give an N-alkoxy group may occur prior to nucleophilic attack, assuming the steric effect of the ortho-halogens is sufficient to allow alkylation at both the nitrogen and oxygen atoms:

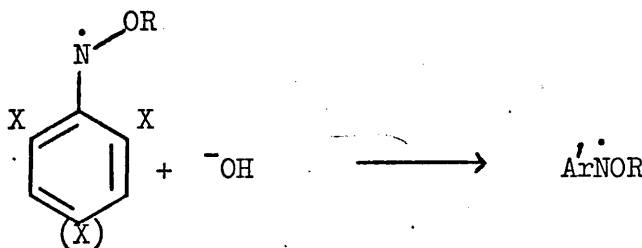
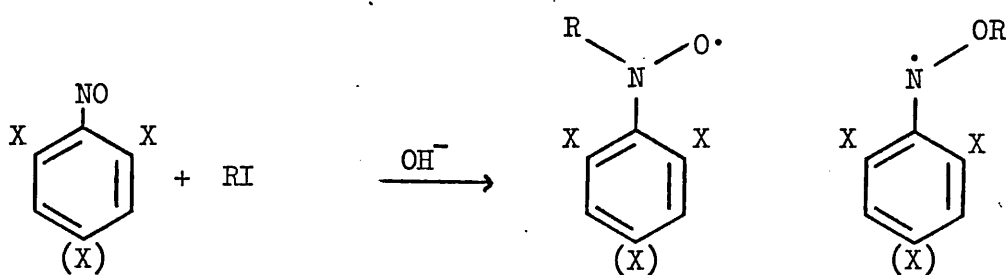

Thus the second type of radical XXV, is thought to be an N-alkoxy-anilino radical ( $\overset{\cdot}{\text{Ar}}\text{NOR}$ ) where the aryl group ( $\overset{\cdot}{\text{Ar}}$ ) is unknown, but is probably derived from the products of nucleophilic substitution by hydroxide ion.

Table 3.5

E.S.R. Spectral Parameters of the Second Class of persistent Radical  
Observed from Reaction (xv).

The values below were obtained from DMSO + ca. 10% H<sub>2</sub>O, unless stated otherwise.

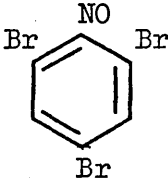
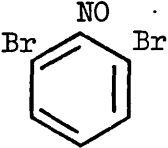
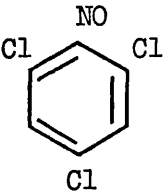
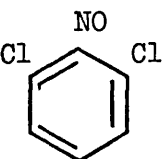
ArNO	Alkyl iodide*		
	CH <sub>2</sub> CH <sub>3</sub>	CH <sub>2</sub> CH <sub>2</sub> CH <sub>3</sub>	CH(CH <sub>3</sub> ) <sub>2</sub>
	9.45 (1N) 1.25 (2H) $g = 2.0054$	9.60 (1N) 1.20 (2H) 2.0055	9.45 (1N) 1.30 (1H) 2.0054
	9.50 (1N) 1.25 (2H) $g = 2.0054$	9.85 (1N) 1.30 (2H) 2.0054	§
	9.60 (1N) 1.20 (2H) $g = 2.0047$	9.60 (1N) 1.30 (2H) 2.0047	9.75 (1N) 1.15 (1H) 2.0047
	9.55 (1N) 1.25 (2H) $g = 2.0047$	9.65 (1N) 1.35 (2H) 2.0047	§

§ The radical was not detected

\* Splitting constants to  $\pm 0.05$  G,  $g$ -values to  $\pm 0.0001$ .

Section 3.12

An E.S.R. Investigation of the Reaction of Nitrosoarenes with  
Polyhalogenomethanes

The investigation of the reactions of nitrosoarenes with simple alkyl halides under reducing conditions was extended to the polyhalogenomethanes, tri-iodomethane (iodoform), tri-bromomethane (bromoform), trichloromethane (chloroform), and di-iodomethane.

When nitrosobenzene was allowed to react with iodoform in DMSO or DMF in the presence of a base (aqueous sodium hydroxide or potassium t-butoxide) a complex e.s.r. signal (Figure 3.24) of high intensity was observed. Use of  $d_5$ -nitrosobenzene in the reaction gave a much simplified spectrum (Figure 3.25). The (1:2:3:2:1) pattern split into doublets was assigned to the interaction of two equivalent nitrogen atoms and one hydrogen atom.

$$\begin{aligned} a_N &= 6.00 \text{ G (2N)} \\ a_H &= 4.50 \text{ G (1H)} \\ g &= 2.0065 \end{aligned}$$

Deuterium coupling was not resolved.

Figure 3.24 has,

$$\begin{aligned} a_N &= 5.95 \text{ G (2N)} \\ a_H &= 4.50 \text{ G (1H)} \\ a_H &= 0.96 \text{ G (6H)} \\ a_H &= 0.48 \text{ G (4H)} \\ g &= 2.0065 \end{aligned}$$

The simulation is given in Figure 3.26. Similar spectra were obtained using bromoform.

The  $g$ -value is ca. 0.0010 higher than that expected for an alkyl phenyl nitroxide, but is in accord with the radical being N, N'-diphenyl-formamidinyl-N-N'-dioxide (XLIII):

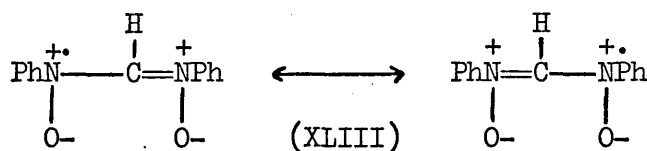

Cyclic nitronyl nitroxides (XLIV, XLV)<sup>122,123</sup> have been well characterised, and one example of an aliphatic acyclic nitronyl nitroxide is known (XLVI).<sup>124</sup>

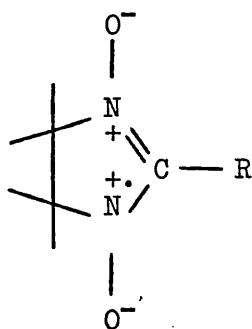

(XLIV)

$\underline{a}_{\text{N}}$  ca. 7.5 G (2N)  
 $\underline{a}_{\text{H}}$  = 3.44 G (1H, R = H)  
 $g$  ca. 2.0065

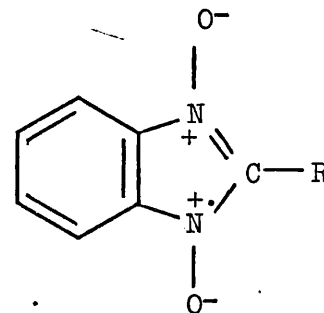

(XLV)

$\underline{a}_{\text{N}}$  ca. 4.2 G (2N)  
 $\underline{a}_{\text{H}}$  = 2.75 G (3H, R = Me)  
 $\underline{a}_{\text{H}}$  ca. 1.0 G (2H)  
 $\underline{a}_{\text{H}}$  ca. 0.75 G (2H)

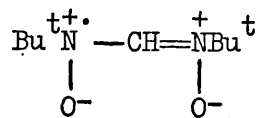

(XLVI)

$$\underline{a}_{\text{N}} = 6.50 \text{ G (2N)}$$

$$\underline{a}_{\text{H}} = 4.13 \text{ G (1H)}$$

$$\underline{g} = 2.0067 \text{ in benzene solution.}$$

Deoxygenated analogues (XLVII) have been identified<sup>125</sup>, in which the nitrogen splittings are now different.

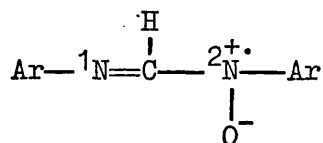

(XLVII)

$$\underline{a}_{\text{N}} \text{ ca. } 7.5 \text{ G (}^2\text{N)}$$

$$\underline{a}_{\text{N}} \text{ ca. } 3.0 \text{ G (}^1\text{N)}$$

$$\underline{a}_{\text{H}} \text{ ca. } 1.5 \text{ G (1H)}$$

Thus the splitting constants and  $\underline{g}$ -value of the radical observed agree well with those expected for the acyclic, aromatic nitronyl nitroxide (XLVIII).

The radical (XLVIII), was also observed from the electrolytic reduction of nitrosobenzene in the presence of iodoform or bromoform (Figure 3.26). Although the polarographic, half-wave reduction potentials of the haloforms are below that of nitrosobenzene in the same solvent,<sup>109,126</sup> the radical was not observed unless the applied potential was sufficient



to generate the nitrosobenzene radical-anion. When the electrolysis was performed in  $d_6$ -DMSO solvent with  $d_5$ -nitrosobenzene the spectrum of (XLIII) still contained a doublet splitting of 4.5 G, showing that the hydrogen atom originated from the haloform. These results rule out the possibility of a carbene intermediate in the formation of (XLIII):

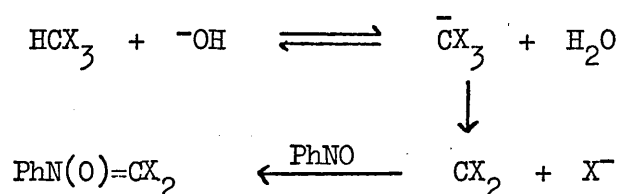

although the presence of a carbene, in the reactions involving a base, is most probable. The mechanism proposed is shown below:

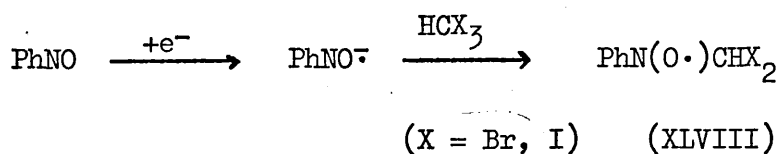

and/or

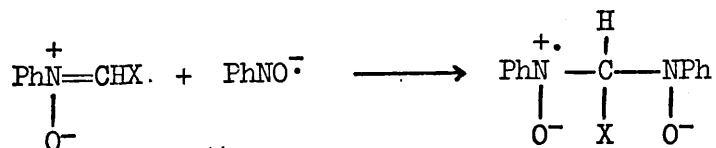
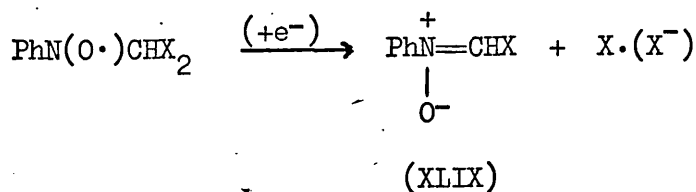
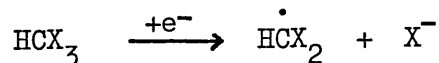

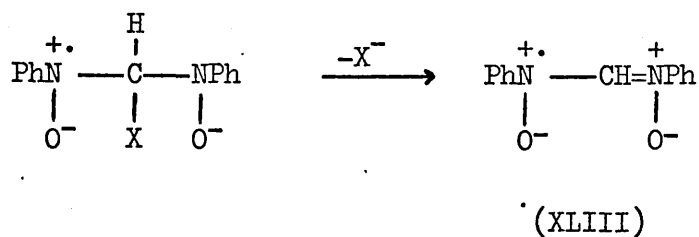

and/or

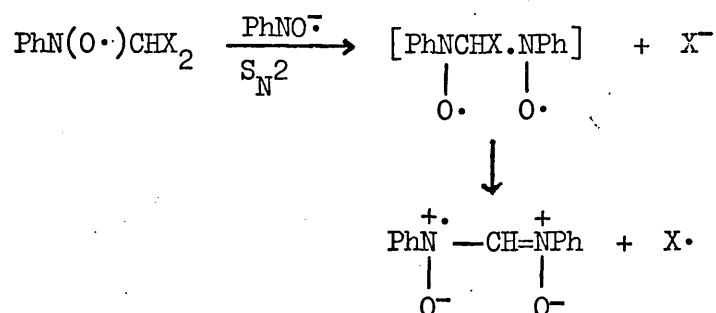

Similar reaction steps have been proposed before. Nucleophilic addition by a nitroxide to an halogenated nitron has been proposed<sup>127</sup> to account for carbonyl nitroxide formation in the reaction of t-butoxyl radicals with haloforms in the presence of nitrosobutane.<sup>127</sup>

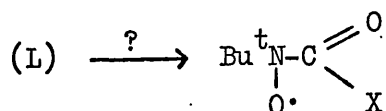
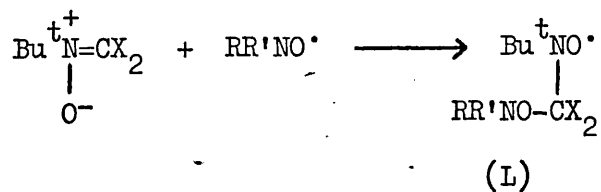
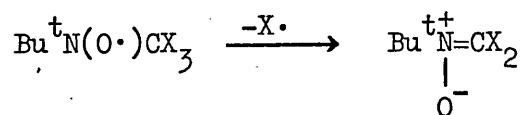
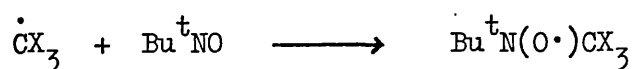

An alternative suggestion for formation of (L) was direct  $S_H2$  displacement of halogen by nitroxide:<sup>128</sup>

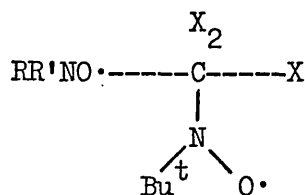

(XLIII) was not observed from the reaction of diiodomethane with nitrosobenzene in the presence of a base, nor during electrolytic reduction. This result is consistent with the formation of an intermediate nitrone, (XLIX), as reaction with diiodomethane would be expected to generate the corresponding methylene nitrone (LI), which is thought to dimerise rapidly to (LII).<sup>22,129</sup>

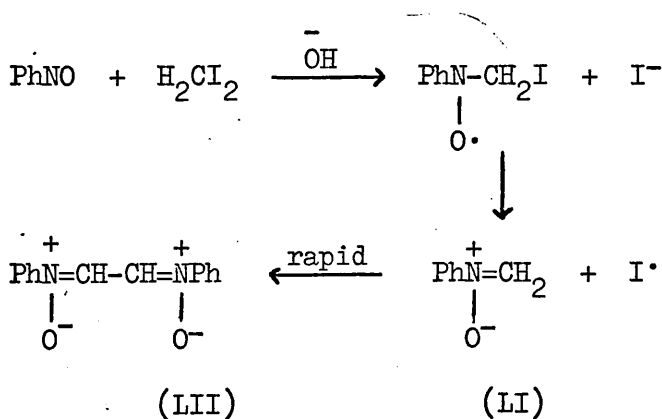

Other routes to (LI), such as the reaction of diazomethane and nitrosobenzene, and the reaction between N-phenylhydroxylamine and dibromomethane in the presence of pyridine, also lead to the dinitrone (LII).<sup>22</sup> Bamberger,<sup>130</sup> discovered a reaction of N-phenylhydroxylamine

with formaldehyde in ethanol solution. The product isolated was thought to be (LIII) on the basis of the elemental analysis.

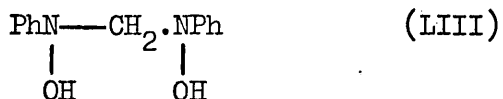

The preparation was repeated and a solid, having the same elemental analysis, was isolated (see Experimental Section). Mild oxidation of the solid with lead dioxide did not generate the expected<sup>22,124</sup> nitronyl nitroxide, (XLIII) but gave phenyl nitroxide, (PhNHO·). In agreement with a later report<sup>131</sup> the material obtained is probably a mixture of N-phenylhydroxylamine and the dinitrone (LII).

The reaction of nitrosoarenes ( $2,4,6\text{-X}_3\text{C}_6\text{H}_2\text{NO}$ , X = Cl, Br, Me or  $2,6\text{-X}_2\text{C}_6\text{H}_3\text{NO}$ , X = F, Cl, Br) with iodoform or bromoform in the presence of base did not lead to the corresponding nitronyl nitroxides. However, 2,4,6-tribromo- and 2,4,6-trichloro-nitrosobenzene reacted with di-iodomethane or iodoform in the presence of sodium hydroxide to give nitronyl nitroxides which did not exhibit a methine proton splitting (for example, Figure 3.27,  $a_{\text{N}}$  (2N) ca. 6.2 G). The radicals were not detected from electrolytic reduction of these nitrosoarenes in the presence of di-iodomethane or iodoform, indicating that alkali is necessary for the reaction. The radicals probably have the structure (LIV):

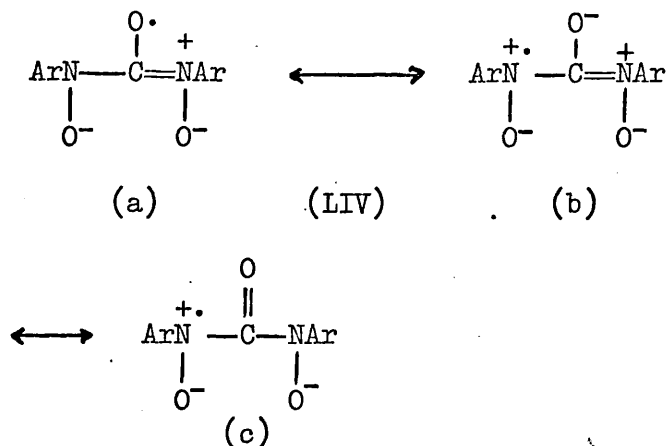

The nitrogen couplings from radical (LIV), compared with those from (XLIII), are expected to be affected by two opposing effects. Firstly, the ortho-halogen atoms will force the benzene ring out of conjugation with the nitroxide function, causing the spin density on the nitrogen atoms to increase. Secondly, spin density may be transmitted to the carbonyl group [represented by (LIVa)], reducing the spin density at nitrogen. Thus a nitrogen coupling from (LIV) similar to that from (XLIII) might be predicted. A cyclic analogue (LV) has been observed previously, having  $a_{\text{N}} = 8.75 \text{ G (2N)}$  in aqueous solution.

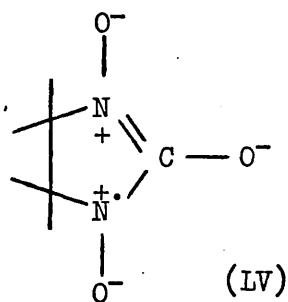

Observation of (LV) from both di-iodomethane and iodoform agrees with a possible nitron intermediate, as now the expected methylene nitron from reaction with di-iodomethane should be slow to dimerise.<sup>129</sup> (LIV) is probably formed from hydroxide ion attack upon the nitron.



Figure 3.24

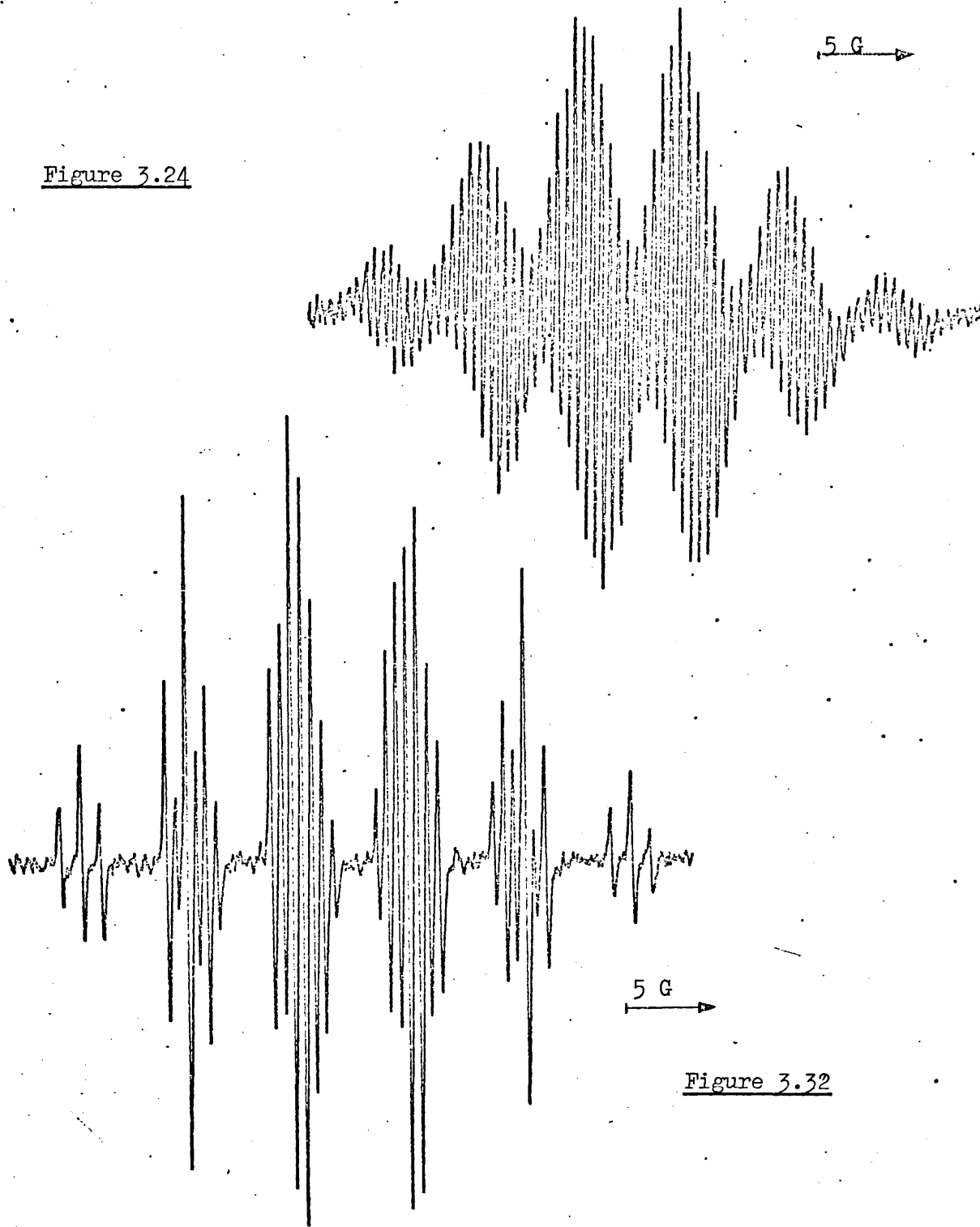

Figure 3.24 ESR spectrum of (XLIII) detected from the reaction of nitrosobenzene with iodoform and sodium hydroxide.

Figure 3.32 ESR spectrum of a secondary nitroxide (Type E) detected from the reaction of (XIV) with methyl iodide and excess sodium hydroxide.

Figure 3.25

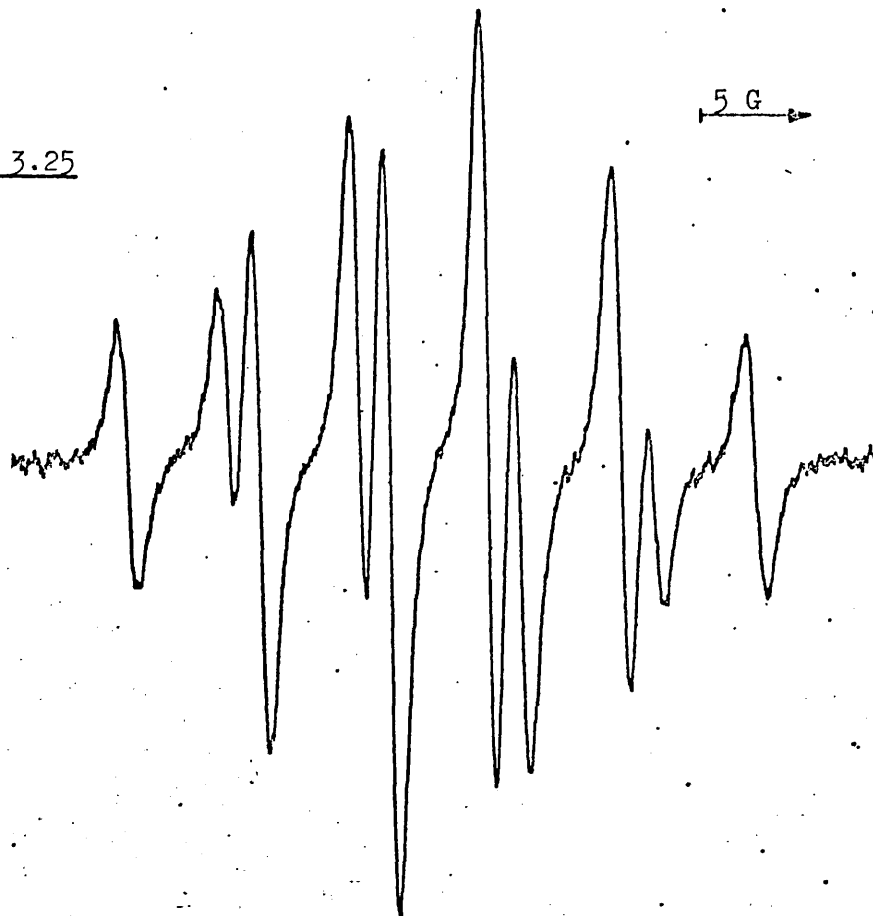

Figure 3.27

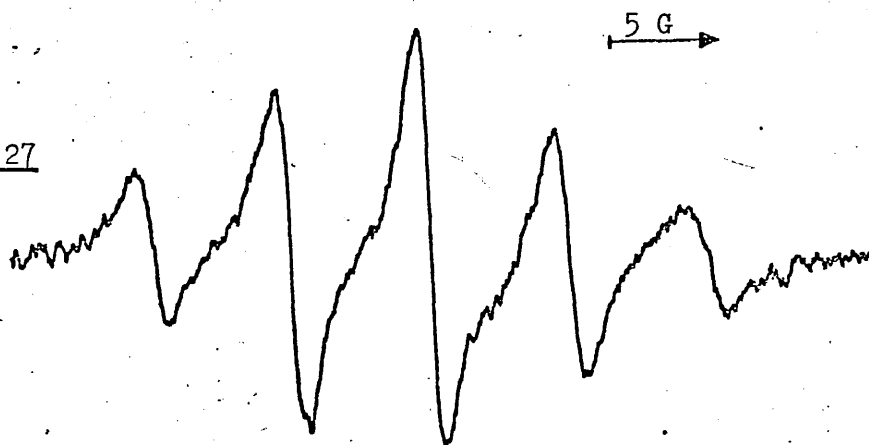

Figure 3.25 ESR spectrum of  $C_6D_5N(O)=CH N(O\cdot)C_6D_5$  detected from the reaction of perdeuteronitrosobenzene with iodoform and sodium hydroxide.

Figure 3.27 ESR spectrum of the nitroxyl nitroxide formed from the reaction of (VIII) with di-iodomethane with sodium hydroxide.



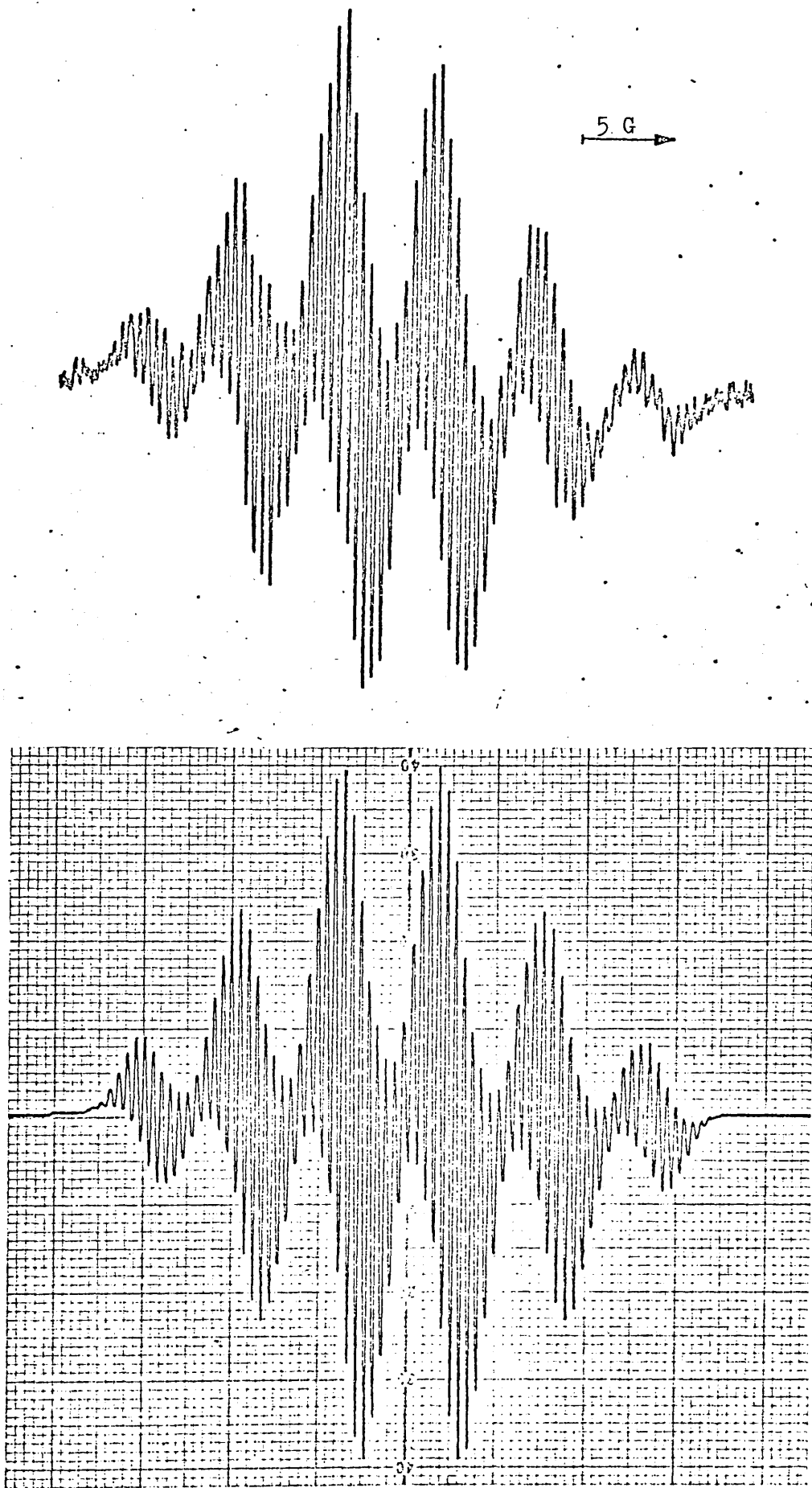

Figure 3.26 ESR spectrum and simulation of (XLIII) detected from the electrolytic reduction of nitrosobenzene and bromoform in DMSO.

### Section 3.13

#### An E.S.R. Investigation of the Reactions of Fluorine Substituted Nitrosoarenes with Alkyl Halides in the Presence of a Base.

The nitrosoarenes investigated in the above reaction were 2,6-difluoro-, 2,4,6-trifluoro-, 2,3,5,6-tetrafluoro- and pentafluoro-nitrosobenzenes. Symmetrically substituted nitroarenes were chosen in order to minimise the complexity of the hyperfine splitting patterns expected from radical derivatives. The reaction conditions were similar to those used for other C-nitroso-compounds examined (ethanol, DMF and DMSO solvents, with usually 10% aqueous sodium hydroxide as the added base.)

#### 2,6-Difluoronitrosobenzene (XI)

The reactions of (XI) with methyl, ethyl, isopropyl and n-propyl iodides were examined. Two types of nitroxide were observed from the reactions depending upon the base concentration and reaction time. The e.s.r. spectra of the two types of radical differed in g-value (by about ca. 0.0003) and nitrogen splitting constant (by about ca. 1.0 G). The spectra observed initially from solutions containing low concentrations of base are assigned as alkyl 2,6-difluorophenyl nitroxides, and the splitting constants in DMSO are given in Table 3.6. The spectrum of 2,6-difluorophenyl methyl nitroxide is given in Figure 3.28; the same spectrum was detected when (XI) trapped methyl radical (from titanium III trichloride, hydrogen peroxide and DMSO). The couplings ( $a_o \sim a_p > a_m$ ) observed for the two alkyl 2,6-difluorophenyl nitroxides show that the nitroxide group is not forced out of the plane of the

Table 3.6

E.S.R. Spectral Parameters of the Nitroxides 2,6-F<sub>2</sub>C<sub>6</sub>H<sub>3</sub>N(R)O• detected from (XI) in Reaction (xv).

Hyperfine splittings/G	Methyl	Ethyl	Isopropyl	n-Propyl
$a_N$ (1N)	12.20	not detected	13.05	not detected
$a_H$ (alkyl)	11.50 (3H)		3.40 (1H) 0.25 (6H)	
$a$ (ring)	1.95 (2F) 1.40 (1H) 0.70 (2H)		1.80 (2F) 1.60 (1H) 0.80 (2H)	
$g$ -value	2.0062		2.0062	

Table 3.7

E.S.R. Spectral Parameters of Secondary Nitroxides observed from (XI)  
in Reaction (xv).

Hyperfine Splittings/G	Methyl	Ethyl	Isopropy	n-Propyl
$a_N$ (1N)	13.20	13.35	14.15	13.75
$a_H$ (alkyl)	12.10 (3H)	8.90 (2H) <u>ca.</u> 0.35 (3H)	4.25 (1H)	8.50 (2H)
$a$ (ring)	1.05 (2) 0.90 (2)	1.05 (1) <sup>†</sup> 0.70 (4) 0.35 (1)	*	*
$g$ -factor	2.0060	2.0060	2.0059	2.0059

\* Ring coupling not resolved

† Unambiguous assignment not possible.

the benzene ring, as occurs for t-butyl 2,6-difluorophenyl nitroxide (Section 1.1). However, the secondary nitroxides (Table 3.7) for example Figures 3.29 and 3.31) exhibit increased nitrogen and alkyl group couplings and a decrease of  $g$ -factor and ring couplings (where  $\underline{a}_o \sim \underline{a}_m \sim \underline{a}_p$ ), expected for the nitroxide group forced out of the plane of the benzene ring.

2,4,6-Trifluoronitrosobenzene (XII) and 2,3,5,6-Tetrafluoronitrosobenzene (XIII).

Persistent radical products were not observed from the reactions involving the above nitroso-compounds, except for the reaction of (XIII) with methyl iodide and sodium hydroxide. Two weak signals showing the same  $g$ -value were observed, one being a broadlined triplet ( $\underline{a}_N = 12.80$  G), the other having the splitting constants given below,

$$\underline{a}_N = 13.00 \text{ (1N) G}$$

$$\underline{a}_H = 12.00 \text{ (3H) G}$$

and coupling from the benzene ring, not analysed from the weak spectra obtained. An authentic spectrum of methyl 2,3,5,6-tetrafluorophenyl nitroxide was detected when titanium III ion and hydrogen peroxide were allowed to react in DMSO in the presence of (XIII); the splitting constants are given below:

$$\underline{a}_N = 12.90 \text{ G (1N)}$$

$$\underline{a}_H = 12.50 \text{ G (3H)}$$

$$(\underline{o}\text{-F})\underline{a}_F = 2.05 \text{ G (2F)}$$

$$(\underline{m}\text{-H})\underline{a}_H = 0.75 \text{ G (2H)}$$

$$(\underline{p-F})_{\underline{a-F}} = 3.00 \text{ G (1F)}$$

Pentafluoronitrosobenzene (XIV)

In the reaction of (XIV) with methyl, ethyl isopropyl or n-propyl iodide in the presence of sodium hydroxide in DMSO, DMF or ethanol, the corresponding alkyl pentafluorophenyl nitroxide was not detected. However, when an excess of base was present persistent radicals were observed.

Addition of excess of sodium hydroxide to solutions of (XIV) and methyl iodide in DMSO or DMF produced a nitroxide (Figure 3.32) the concentration of which declined rapidly about two minutes after addition of the base. Apart from coupling to one nitrogen atom (ca. 13.0 G) and a methyl group (ca. 11.75 G) a splitting of ca. 2 G was observed from two equivalent nuclei having  $I = 1/2$ . Similar spectra were observed when ethyl or isopropyl iodide was used in place of methyl iodide (Table 3.8). With  $d_3$ -methyl iodide the expected spectrum was observed initially (Table 3.8), but this was later replaced by the spectrum from a mixture of two nitroxides having the splitting constants (Gauss) given below.

Radical F	13.30 (1N)	Radical G	13.75 (1N)
	1.75 (3D)		1.75 (3D)
	1.75 (1)		

Similarly, when (XIV) and methyl iodide were allowed to react in alkaline ethanolic solution mixtures of nitroxides were detected

Table 3.8

Splitting constants of the Nitroxides (Type E) detected from (XIV) in Reaction (xv), in DMSO or DMF solution.

Alkyl group R	Splitting Constants $\pm 0.05$ G		
	$\underline{a}_N$	$\underline{a}_R$	$\underline{a}$ (other)
CH <sub>3</sub>	13.00	11.75 (3H)	2.25 (2)
CD <sub>3</sub>	12.70	1.75 (3D)	2.25 (2)
CH <sub>2</sub> CH <sub>3</sub>	13.00	9.00 (2H)	2.00 (2)
CH(CH <sub>3</sub> ) <sub>2</sub>	13.25	3.90 (1H)	1.90 (2)

(H, J and K, for example Figure 3.33).

Radical H	13.30 (1N)	Radical J	14.25 (1N)
	12.20 (3H)		12.90 (3H)
			0.25 (3)
Radical K	singlet		

The results in this section indicate that on increasing the fluorine substitution in the ring of the nitrosoarene, from 2,6-difluoro- to pentafluoro-, there is a parallel increase in the number of side-reactions. Only with (XI) were the corresponding alkyl aryl nitroxides observed along with, nitroxides of the structure R'N(R)O• (from ArNO + RI + NaOH), where R' is unknown. There are two likely structures for the group R'. It may be solvent-derived or an alkoxy-substituted aryl group. Possible routes to the two possible nitroxides are outlined below.

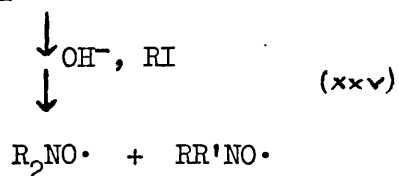
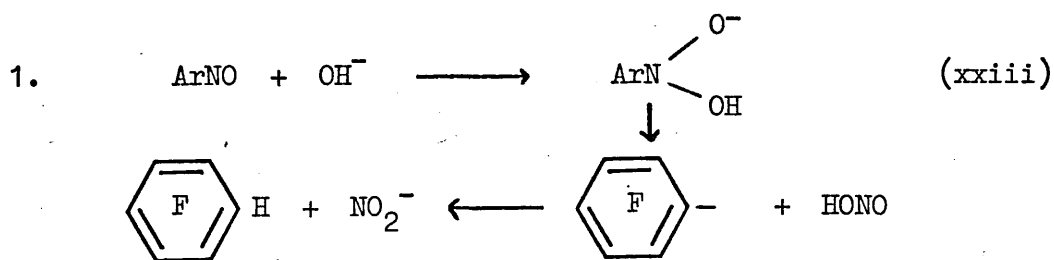



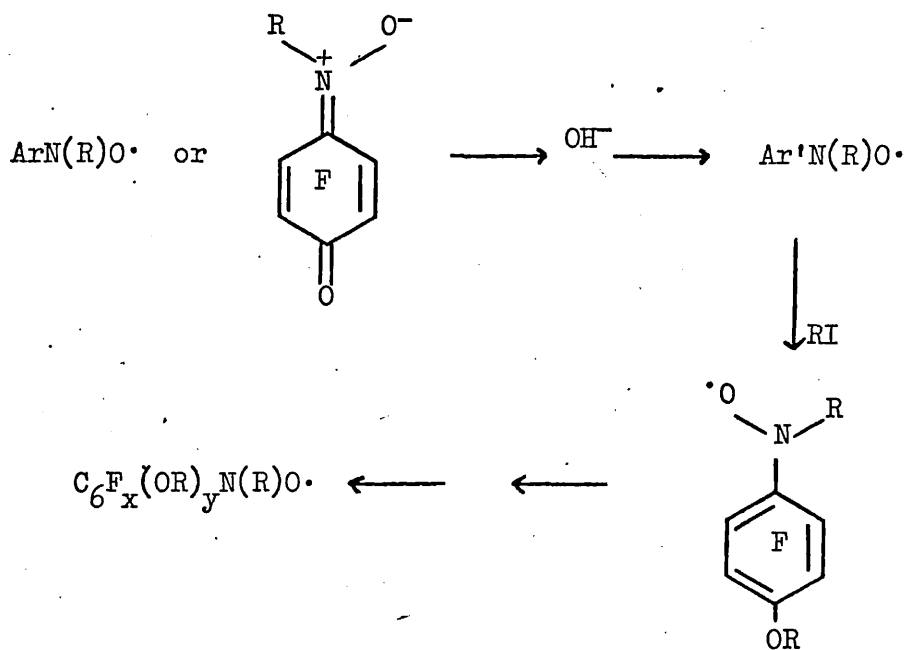
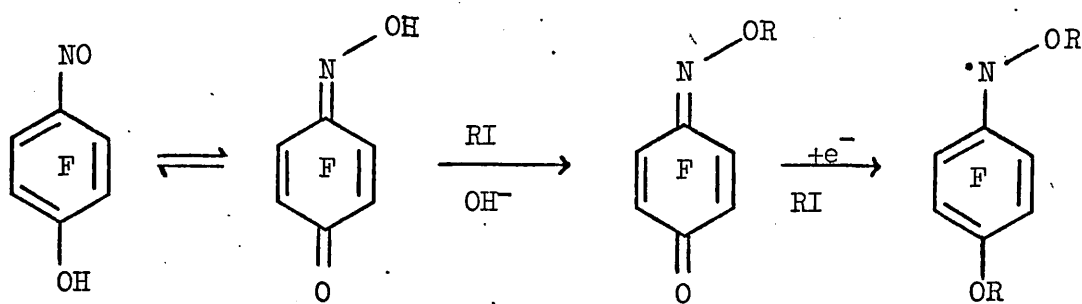
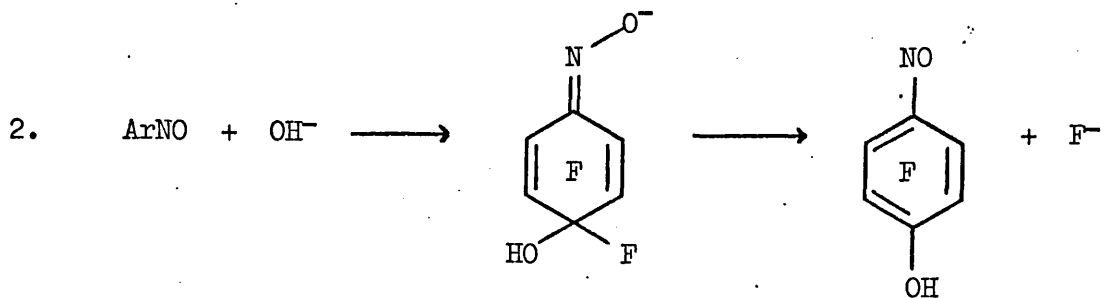

Step (xxiii) is analogous to the reaction of 2,6-dichlorobenzaldehyde with base to give 1,3-dichlorobenzene:<sup>120</sup>

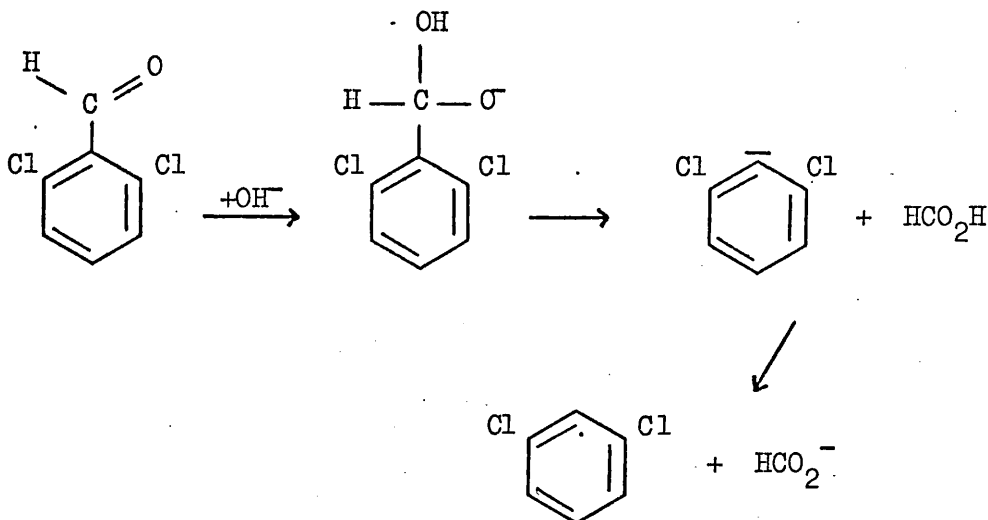

Step (xxiv) is a known reaction.<sup>121</sup> Step (xxv) was verified for nitromethane, amyl nitrite or sodium nitrite, with methyl iodide, and nitroxides observed were dimethyl nitroxide and the type  $\text{CH}_3\text{N}(\text{CH}_2\text{X})\text{O}\cdot$  where X did not exhibit any hyperfine coupling. However, the nitrogen splitting constant of the secondary radicals (ca. 13 G) is too small for a dialkyl nitroxide (ca. 15 G) and splittings of ca. 2 G observed from the reactions of (XIV) are too small for a  $\beta$ -H coupling.

In the second scheme nucleophilic aromatic substitution followed by alkylation of the products is shown. Alkylation can occur before or after the substitution reaction. However, if substitution occurred prior to alkylation of the nitroso-group, then a nitrosophenol, tautomeric with the quinon-oxime, would result. This tautomer is alkylated by alkyl halides under basic conditions to give (LVI) and not (LVII).<sup>121</sup>

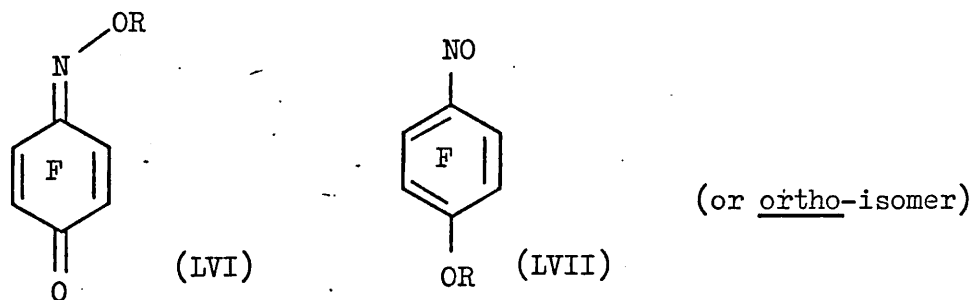

The splittings observed for the secondary radicals do not fit those expected for a radical of  $\text{Ar}\dot{\text{N}}\text{OR}$  structure ( $a_{\text{N}}$  and  $a_{\text{R}}$  are too large), which would be expected to be long-lived under the reaction conditions (see Section 3.11). Thus it is probable that alkylation of the nitroso-group occurs before substitution in the ring, but the primary nitroxide concentration does not become high enough for observation of its e.s.r. spectrum, except for the less reactive 2,6-difluoronitrosobenzene.

The secondary nitroxides derived from (XI) (Table 3.7) have spectra which show that the nitroxide group is forced further out of the plane of the benzene ring than for the corresponding alkyl 2,6-difluorophenyl nitroxide. This demonstrates that at the ortho-position substitution by a more bulky group has resulted and the radicals are consequently assigned the structure:

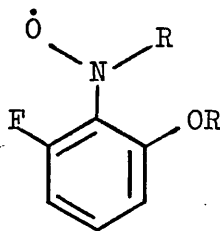

By analogy, the secondary radicals (Table 3.8) derived from (XIV) are thought to be alkyl 2,4,6-trialkoxy-3,5-difluorophenyl nitroxides.

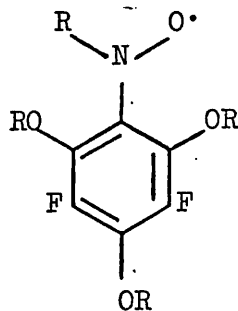

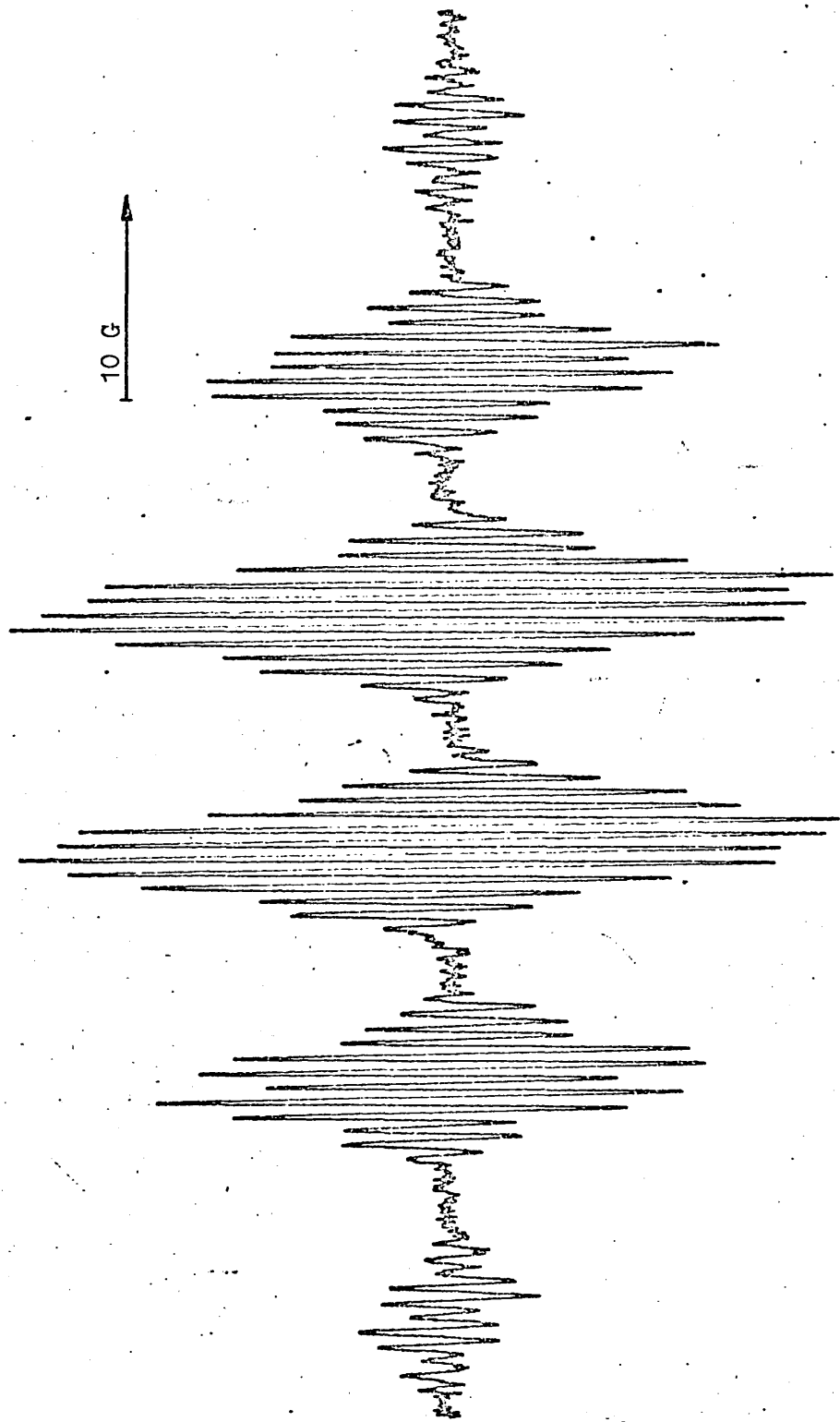

Figure 3.28 ESR spectrum of methyl 2,6-difluorophenyl nitroxide detected from the reaction of (XI) with methyl iodide and sodium hydroxide in aqueous DMSO.

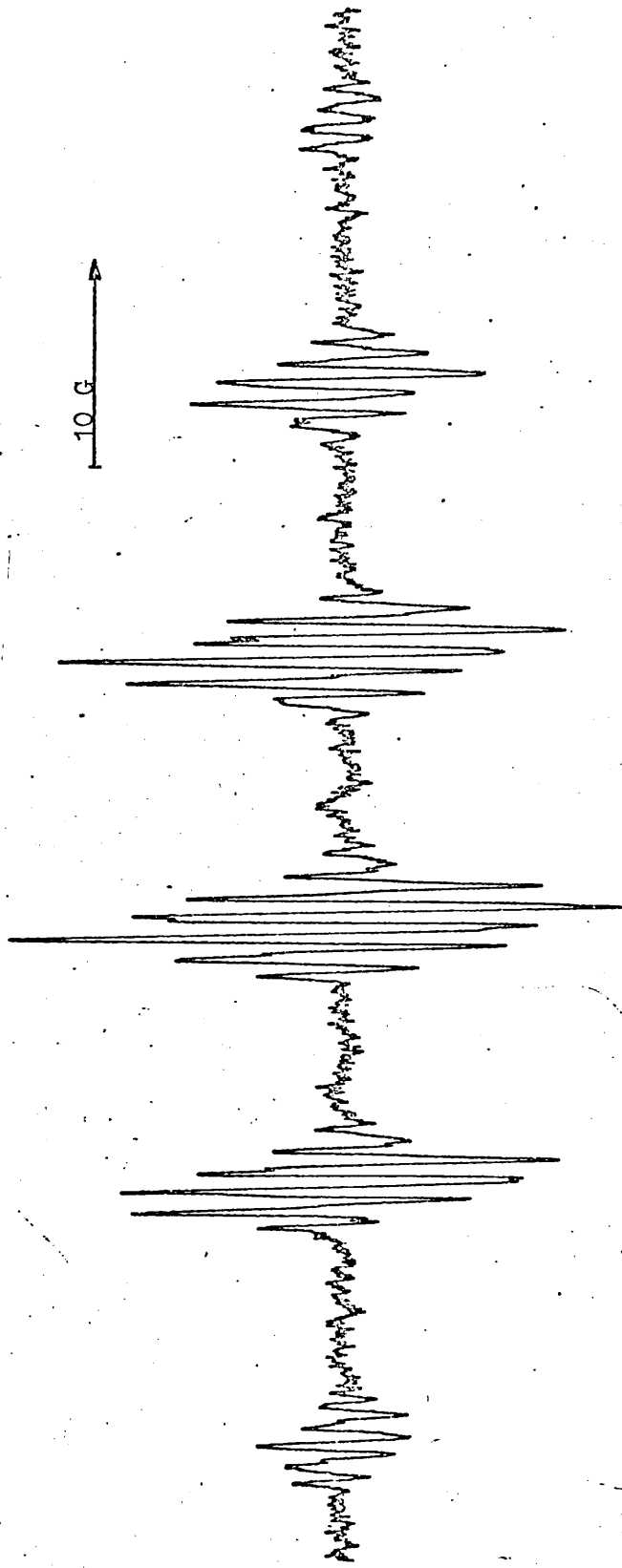

Figure 3.29 ESR spectrum of a secondary nitroxide detected from the reaction of (XI) with methyl iodide and sodium hydroxide in aqueous DMSO.

Figure 3.30

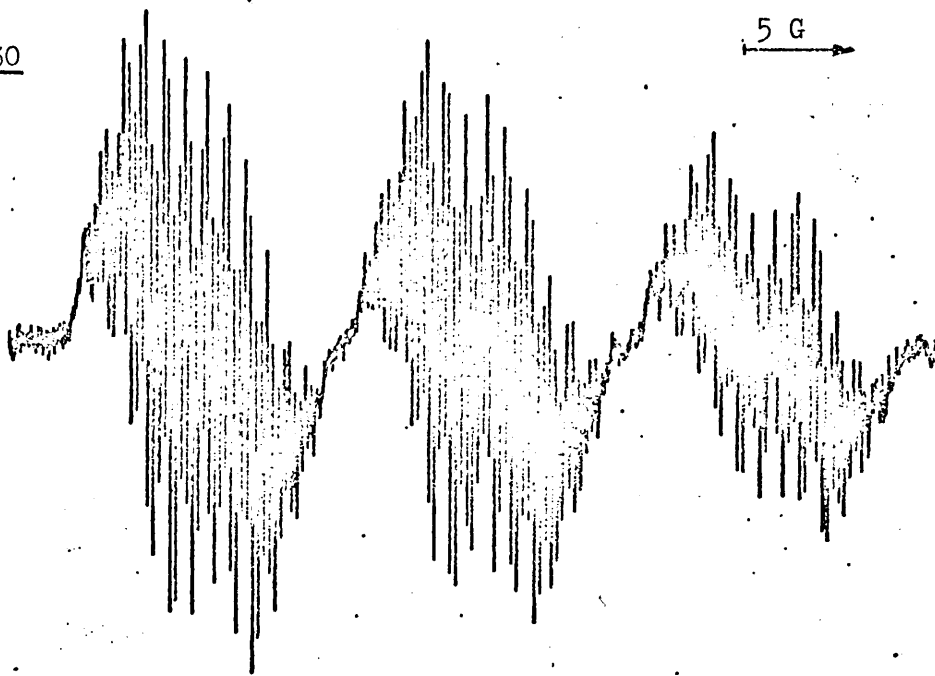

Figure 3.31

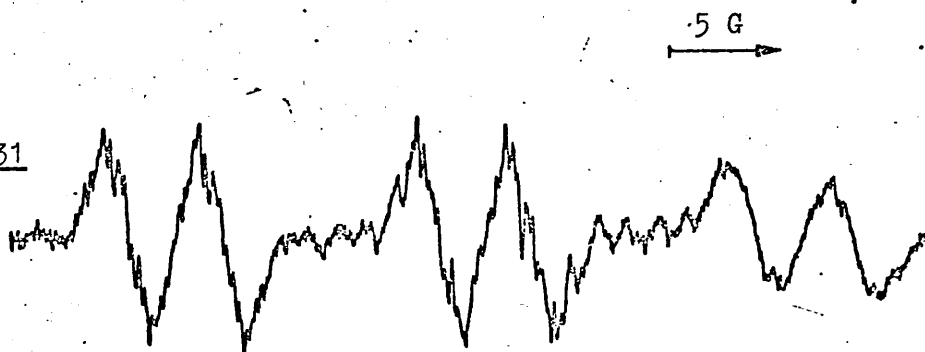

Figure 3.30 ESR spectrum of isopropyl 2,6-difluorophenyl nitroxide detected from reaction of (XI) with isopropyl iodide and sodium hydroxide in aqueous DMSO.

Figure 3.31 ESR spectrum of a secondary nitroxide detected from the above reaction.

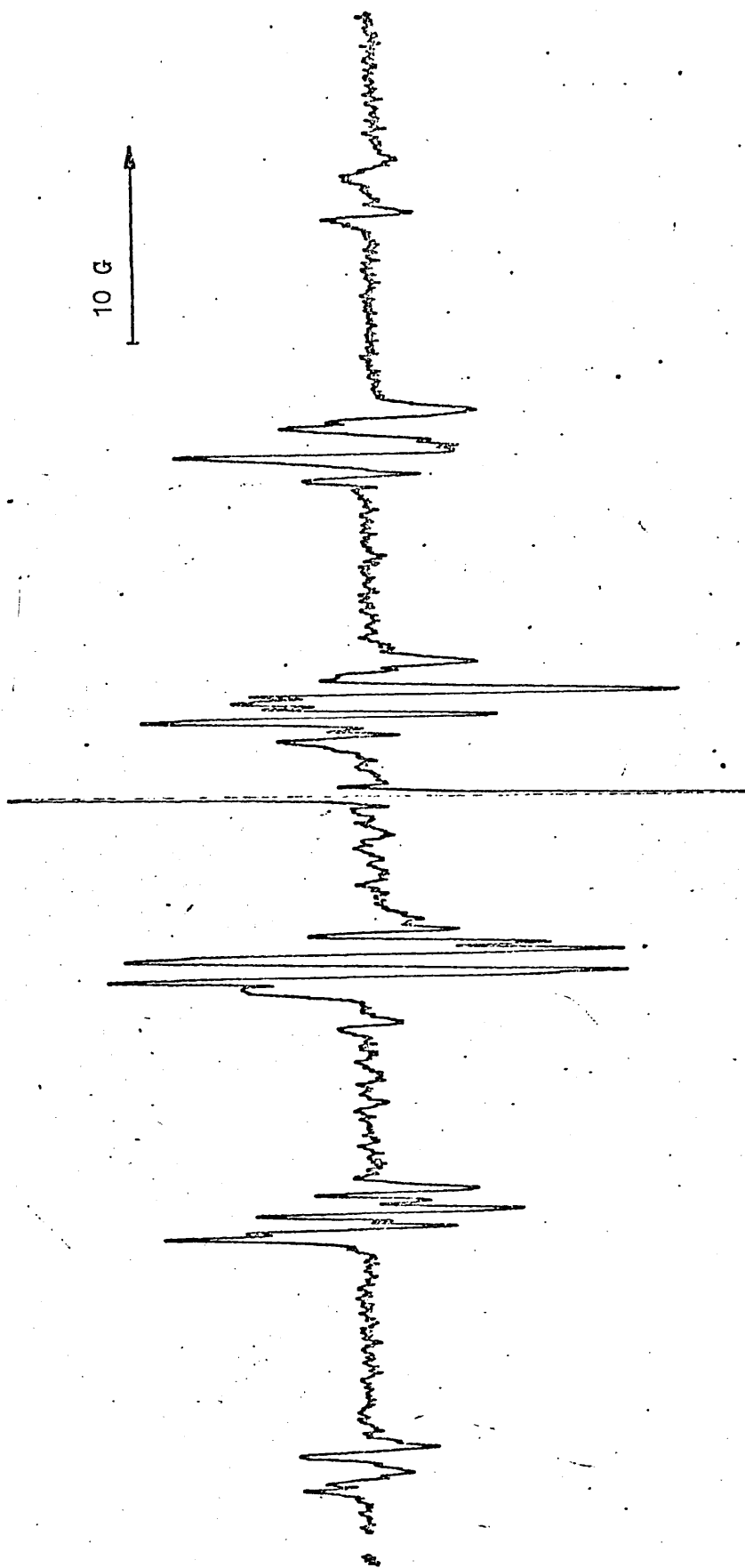

Figure 3.33 ESR spectrum of a mixture of nitroxides (H, J and K) detected from the reaction of (XIV) with methyl iodide in alkaline aqueous ethanol.

CHAPTER 4

EXPERIMENTAL

All the electron spin resonance spectra were recorded on a Varian E4 (X-band) spectrometer with 100 kHz modulation. A flat cell was used for the polar solvents DMSO, DMF and ethanol. Where appropriate, DMSO and DMF were dried using Linde type A3 molecular sieve (BDH).

Reactions Involving Bases

The reactions involving the use of base (aqueous sodium hydroxide, potassium t-butoxide, sodium methoxide or sodium hydride) were carried out under static conditions at room temperature, the reactions being too slow to require the use of a flow system.

Usually the nitroso-compound was dissolved in a suitable solvent (DMSO, DMF or ethanol) to give a concentration of ca.  $10^{-2}$  mol dm<sup>-3</sup>. The alkyl halide ( $10^{-2}$  to  $5 \times 10^{-2}$  mol dm<sup>-3</sup>) was added when required and the base, usually aqueous sodium hydroxide, was added dropwise as a 10% solution to give a concentration of  $10^{-3}$  mol dm<sup>-3</sup> or greater. On addition of the base, an immediate change of colour of the solution was usually observed and upon transfer to the spectrometer a spectrum could be recorded. Occasionally a longer reaction time was required before observation of the spectrum of a kinetically stable radical was possible.

When the elimination of oxygen from the reaction solution was necessary, freeze-thaw degassing using a vacuum line was employed. The cycle was usually repeated three times. The solutions were



transferred using syringes. The reaction vessel and cell were purged with oxygen-free nitrogen before use and were protected from the atmosphere by means of a serum cap.

#### Radical Generation by Photolysis

A water-cooled, 100 W, high pressure mercury arc lamp (Varian Limited) was used as a source of ultra-violet light. A lens system concentrated the light into a 1 cm diameter beam coincident with the spectrometer microwave cavity. Samples were irradiated in the quartz, flat cell.

Irradiation of the C-nitroso-compound and alkyl halide usually gave rise to detectable concentrations of the alkyl aryl nitroxide. Where appropriate, tri-n-butyltin hydride was added to increase the rate of generation of alkyl radicals. The solvents used and solute concentrations were similar to those used in the reactions involving bases.

#### Electrolytic method of Radical Generation

Radical-anions were generated by an electrolytic procedure similar to that introduced by Geske and Maki.<sup>104</sup> The electrolytic reductions were carried out in the cavity of the spectrometer. A mercury or platinum wire cathode was used. The active surface of the cathode was positioned approximately one third of the way up the flattened section of the cell (Figure 4.1). A platinum-wire anode was suspended in the electrolyte reservoir above the flattened section of the cell. The solvents used were dried DMSO and DMF as they had sufficiently high dielectric constants to allow electrolytic dissociation to form highly

conducting solutions, and were stable to reduction (up to  $-3.0$  V versus saturated calomel electrode (SCE) with tetra-*n*-butylammonium cation.<sup>109</sup>) The supporting electrolyte (needed to increase the conductivity of the solution) used was tetra-*n*-butylammonium iodide or tetra-ethylammonium perchlorate. These salts are readily soluble in DMSO and DMF ( $0.1$  mol  $\text{dm}^{-3}$  concentration was used<sup>104</sup>) and inert over the cathodic potential range of interest. Solutions were made up with the reducible substance present at  $10^{-2}$  to  $10^{-3}$  mol  $\text{dm}^{-3}$  concentrations. Similar concentrations of alkyl halides were also used where needed.

The reductions were carried out using a constant potential d.c. source. The current flowing through the cell was monitored (Figure 4.2) using a microammeter (20 or 100  $\mu\text{A}$  full scale deflection). Potential differences were measured using a digital voltmeter of internal resistance  $10$   $\text{M}\Omega$ ; drawing less than  $0.2$   $\mu\text{A}$  current. The potential differences measured were that across the working electrodes and that between the mercury surface and a reference aqueous saturated calomel electrode (SCE). In order to keep water out of the electrolyte compartment the SCE was connected by means of an agar salt bridge saturated with aqueous potassium chloride. The salt bridge was connected to a capillary ('Luggin capillary') filled with electrolyte and drawn out into a fine tip. The tip was placed as close as possible to the mercury surface. This arrangement was adopted in order to minimise the effect of the potential (IR) drop occurring in the electrolyte due to the passage of current. As virtually no current flows in the cathode-reference electrode circuit (hence no IR drop) the salt bridge and Luggin capillary have the effect of extending the reference electrode to the mercury surface.

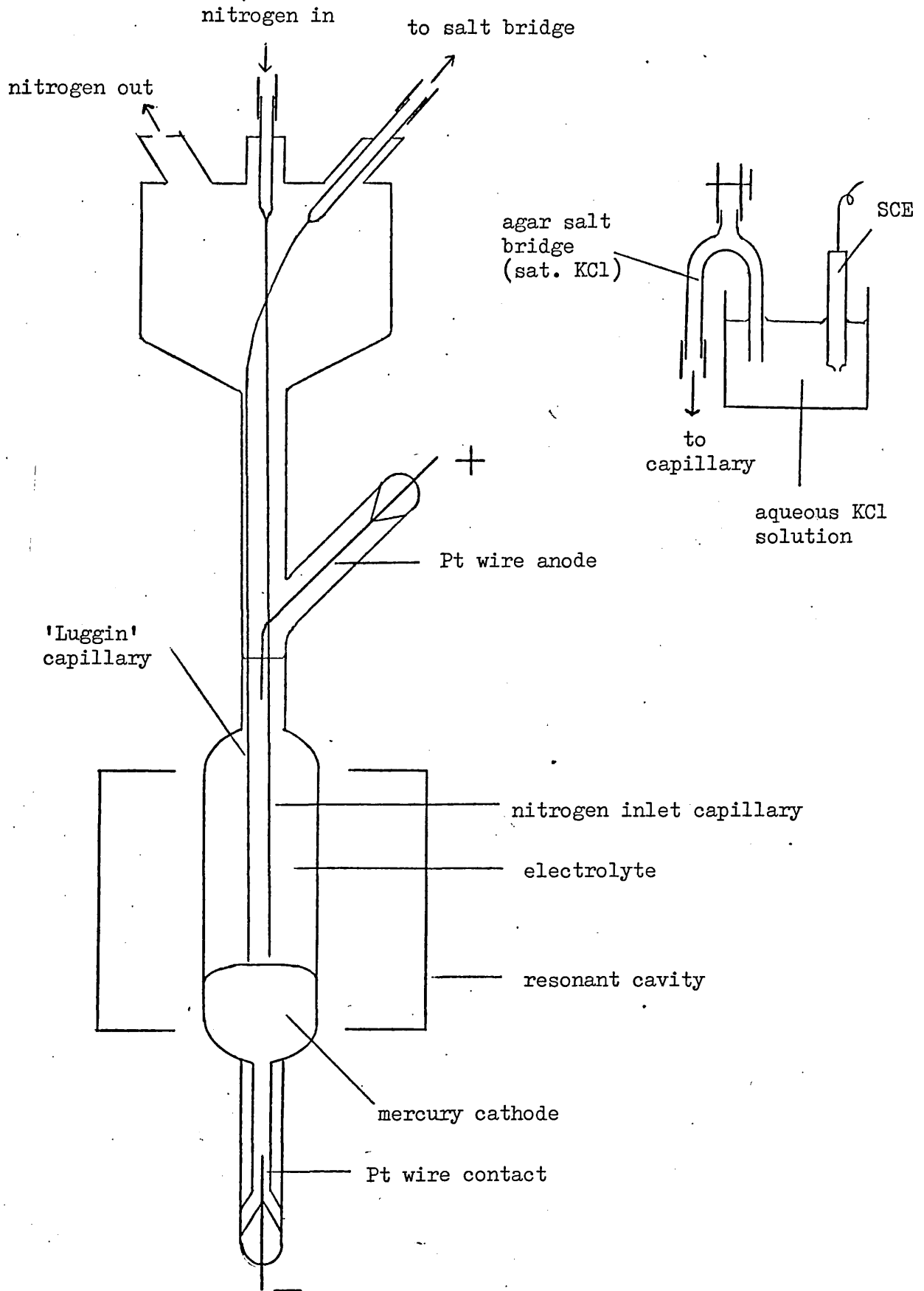
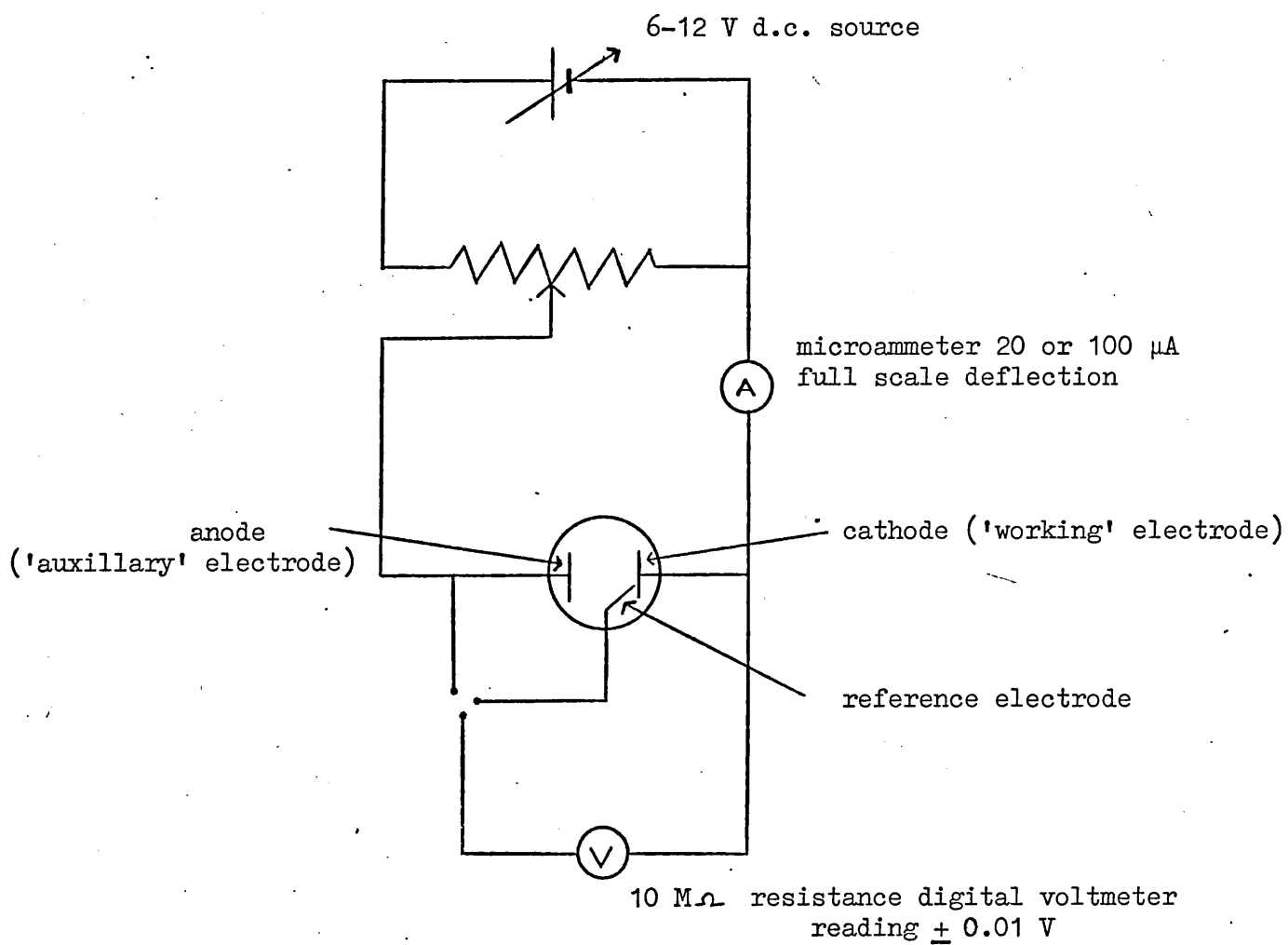

Figure 4.1 Electrolytic reduction cell.

Figure 4.2 Electrolytic reduction circuit diagram.



The electrolyte was deoxygenated when required, by the bubbling of oxygen free nitrogen through the solution in the cell. The nitrogen was introduced through a fine capillary passing into the flat section of the cell to close to the cathode surface. When spectra were recorded the capillary was raised to a position above the flattened section of the cell to prevent interference by the nitrogen of the signal recorded.

#### Isotropic g-Factor Measurement

A relative method of g-factor determination was adopted involving measurement of the field difference between the centres of the spectrum of a radical of known g and the spectrum of the radical of interest. This was achieved in practice by attaching a thin capillary, containing a solution of the standard g-value radical, to the flat cell. The capillary was positioned so that it was parallel to and against a narrow side of the flattened part of the cell. With this arrangement it is assumed that the magnetic field is the same for both sample and standard. The g-factor of the sample is given by:

$$g = g_s \left( 1 + \frac{\delta}{H} \right)$$

derived from the resonance condition, where g is the sample g-factor, g<sub>s</sub> is the standard g-factor, H and H<sub>s</sub> are the magnetic fields at the centre of the sample and standard spectra respectively, and  $\delta = (\underline{H}_s - \underline{H})$ .

As standards Fremy's salt ( $g = 2.00550 \pm 0.00005$  in saturated aqueous sodium carbonate solution<sup>132</sup>) and p-benzosemiquinone radical-

anion ( $g = 2.004665$  in *t*-butyl alcohol<sup>133,134</sup>) were used. The sample  $g$ -factors were determined to within  $\pm 1 \times 10^{-4}$ ; higher accuracy was unnecessary as solvent-induced variation of  $g$  was of the same order of magnitude for the radicals under examination.

#### Preparation of C-nitroso Compounds

2-Methyl-2-nitrosopropane (Aldrich) and pentafluoronitrosobenzene (Bristol Organics) were commercial samples and *p*-nitroso-*N,N*-dimethylaniline was also available. Nitrosobenzene was prepared by the usual route of initial reduction of nitrobenzene to *N*-phenylhydroxylamine, followed by controlled oxidation.<sup>135</sup> A sample of fully deuterated nitrosobenzene was kindly provided by Dr. J. Sandall.

The 2,6- and more highly substituted halogeno- or alkyl-nitrosobenzenes were prepared by controlled oxidation of the parent aniline. The oxidant was either peracetic acid or *m*-chloroperoxybenzoic acid.

#### Bromo- and Chloro-Substituted Nitrosobenzenes

2,6-Dibromo-, 2,4,6-tribromo- 2,6-dichloro- and 2,4,6-trichloro-nitrosobenzene were prepared by adapting the method of Holmes and Bayer.<sup>136</sup> In place of 30% aqueous hydrogen peroxide and glacial acetic acid with catalytic amounts of sulphuric acid, mixtures of peracetic acid in glacial acetic acid were used.

In general:

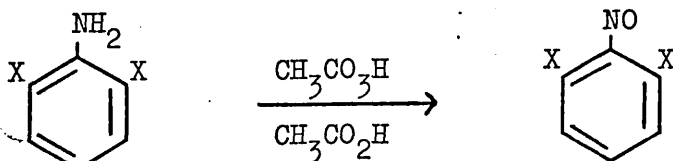

(precipitated as the dimer)

No attempts were made to maximise the yield of nitroso-dimer obtained.

A typical method:

2,6-Dichloroaniline (10 g) was added to a solution of peracetic acid (40%; 50 cm<sup>3</sup>) in glacial acetic acid (150 cm<sup>3</sup>). The stirred solution was left overnight, after which the precipitated nitroso-dimer was filtered off. Further product could be obtained by pouring the remaining reaction mixture into water. The colourless dimer was recrystallised from ethanol (m.p. = 173-174 °C, lit.<sup>136</sup> m.p. = 173-175 °C from acetic acid, 175-176 °C after vacuum sublimation.)

#### 2,4,6-Trialkylnitrosobenzenes

2,4,6-Trimethylnitrosobenzene and 2,4,6-tri-t-butylnitrosobenzene were prepared by reported methods.<sup>139</sup>

#### 2,4,6-Trimethylnitrosobenzene

2,4,6-Trimethylnitrosobenzene was prepared by oxidation of the corresponding aniline.

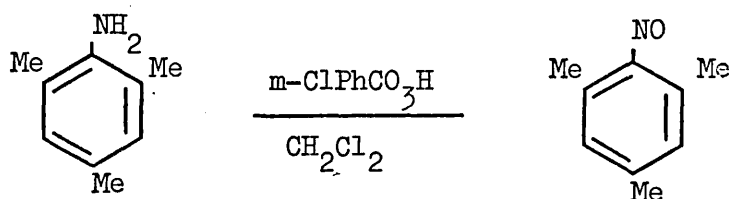

The aniline (1 mol) and m-chloroperoxybenzoic acid (2 mol) were allowed to react in dichloromethane at 0 °C for approximately 60 hours. After filtering off the solid benzoic acid-peroxybenzoic acid mixture the reaction solution was washed with 10% aqueous sodium carbonate and dried over anhydrous sodium sulphate. The dichloromethane was then

Table 4.1

Melting points of and recrystallising solvents used for the chlorine or bromine substituted nitrosobenzenes.

Substituted Nitrosobenzene	m.p./°C	recrystallising solvent.	literature m.p./°C
2,6-dibromo	135-136	ethanol	135-136 <sup>136</sup> 135-136 <sup>137</sup>
2,4,6-tribromo	121-122	acetic acid	120 <sup>138</sup> 122-123 <sup>136</sup>
2,6-dichloro	173-174	ethanol	175-176 <sup>136</sup> 174-175 <sup>137</sup>
2,4,6-trichloro	143-144	acetic acid	145-146 <sup>136</sup>



evaporated from the filtered solution and the red-brown product was washed with pet. ether (b.p. 60-80 °C), which dissolved the coloured material leaving behind the colourless nitroso-dimer. The dimer was recrystallised from methanol to yield colourless plates, m.p. = 121-122 °C (122 °C)<sup>140</sup>.

### 2,4,6-Tri-t-butylnitrosobenzene

The starting material was *p*-di-*t*-butylbenzene, which was alkylated by means of a Friedel-Crafts reaction<sup>141</sup> using *t*-butyl chloride with aluminium chloride catalyst below 0 °C. The 1,3,5-tri-*t*-butylbenzene product, obtained by carefully adding water after 50 minutes, was extracted with ether and recrystallised from ethanol.

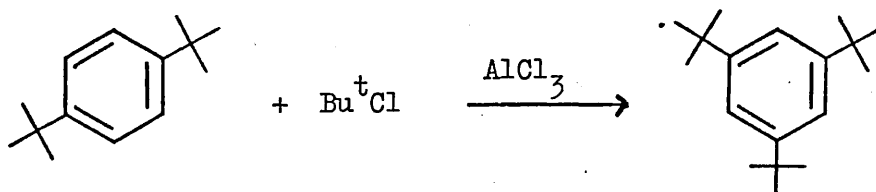

This trialkylbenzene was nitrated and the product reduced by sodium amalgam in ethanol to 2,4,6-tri-*t*-butylaniline.<sup>142</sup>

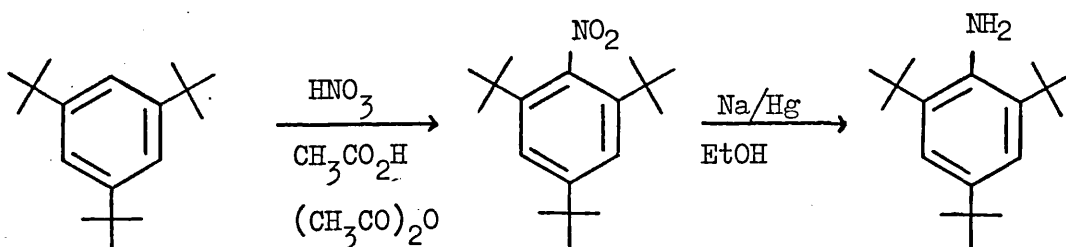

To a mixture of 1,3,5-tri-*t*-butylbenzene (2.85 g), glacial acetic acid (5 cm<sup>3</sup>) and acetic anhydride (10 cm<sup>3</sup>), a mixture of glacial acetic acid (2.5 cm<sup>3</sup>) and nitric acid (d 1.52; 2.0 cm<sup>3</sup>) was added dropwise

below 0 °C. The temperature was then allowed to rise to 20 °C over 4 hours and the mixture allowed to stand for 2 days. When poured into water the almost pure nitro-compound precipitated. On recrystallisation from ethanol almost colourless crystals were obtained, m.p. = 205-206 °C, (m.p. = 205-206 °C<sup>142</sup>).

A mixture of 2,4,6-tri-*t*-butylnitrobenzene (2.67 g) and absolute ethanol (50 cm<sup>3</sup>) was gently refluxed for 5 hours over sodium amalgam (70 g; 4% w/w). The solution was poured out while still warm into 500 cm<sup>3</sup> of water to yield the aniline. Recrystallisation from 95% ethanol gave colourless crystals, m.p. = 147 °C (147-148 °C<sup>142</sup>).

The final stage was oxidation of the aniline by *m*-chloroperoxybenzoic acid in dichloromethane at 0 °C,<sup>139</sup> as in the preparation of 2,4,6-trimethylnitrosobenzene. The crude product obtained was purified using column chromatography on alumina, giving a good separation from the nitro-derivative by-product. The 2,4,6-*t*-butylnitrosobenzene was bright green and monomeric in the solid state, the bulky *t*-butyl groups apparently prevent dimer formation.<sup>139</sup> The product had the melting point 166-167 °C (lit.<sup>139</sup> 167-168 °C from methanol), Found: C 77.7, H 10.6, N 4.9%. Calc. for C<sub>18</sub>H<sub>29</sub>NO: C 78.5, H 10.6, N 5.1%.

#### Fluoro-substituted nitrosobenzenes

2,6-Di-; 2,4,6-tri-; and 2,3,5,6-tetra-fluoronitrosobenzenes were prepared by use of or adaptation from a reported method.<sup>137</sup>

For example:

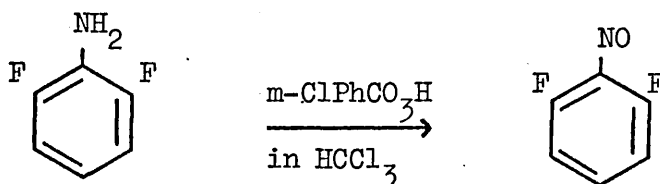

A solution of m-chloroperoxybenzoic acid (0.058 mol, 75 cm<sup>3</sup>) was slowly added at room temperature to a stirred solution of 2,6-difluoroaniline (0.022 mol) in chloroform (50 cm<sup>3</sup>). After two hours reaction time the small excess of peroxy-acid was reduced by washing with sodium thiosulphate solution (2%). The benzoic acid product was removed by repeated washing with aqueous sodium carbonate solution (5%). The remaining solution was then washed with water, dried (anhydrous sodium sulphate) and the chloroform evaporated in vacuo. The product obtained was recrystallised from ethanol, m.p. = 107-109 °C (lit.<sup>137</sup> 108.5-109.5 °C from ethanol). Found: C 50.4, H 2.1, N 9.7%. Calc. for C<sub>6</sub>H<sub>3</sub>F<sub>2</sub>NO: C 50.0, H 2.1, N 9.7%.

For 2,4,6-trifluoronitrosobenzene, m.p. = 115 °C recrystallised twice from ethanol. (C 45.2, H 1.2, N 8.8%. C<sub>6</sub>H<sub>2</sub>F<sub>3</sub>NO requires C 44.7, H 1.2, N 8.7%).

For 2,3,5,6-tetrafluoronitrosobenzene, m.p. = 65-66 °C recrystallised twice from ethanol, (lit.<sup>143</sup> m.p. = 66 °C from ethanol). Found: C 41.5, H 0.5, N 8.1%. Calc. for C<sub>6</sub>H<sub>1</sub>F<sub>4</sub>NO: C 40.2, H 0.56, N 7.8%.

Preparation of 4H, 4'H-Octafluoroazobenzene and 2H, 7H-Hexafluorophenazine

4H, 4'H-Octafluoroazobenzene (LVIII) and 2H, 7H-hexafluorophenazine (LIX) were obtained as products of the same reaction.<sup>144</sup>

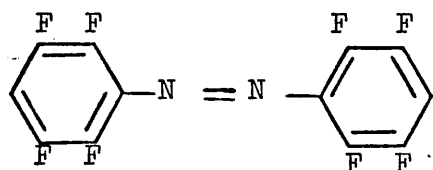

(LVIII)

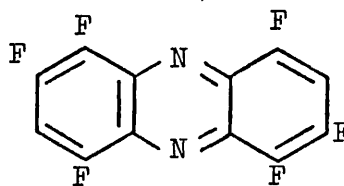

(LIX)

Oxidation of 2,3,5,6-tetrafluoroaniline by lead tetra-acetate in benzene under reflux leads to the formation of (LVIII) and (LIX) as major products. Lead tetra-acetate (30 g, 0.066 mol) was added to 2,3,5,6-tetrafluoroaniline (6.5 g, 0.04 mol) in benzene (150 cm<sup>3</sup>) and the mixture refluxed for one hour. The brown suspension obtained was diluted with 250 cm<sup>3</sup> of benzene, washed successively with aqueous 50% acetic acid, saturated aqueous sodium hydrogen carbonate and water, then dried (MgSO<sub>4</sub>). After evaporation of the solvent the residue was chromatographed on alumina. Elution with a mixture of 30% benzene and 70% light petroleum (b.p. 60-80 °C) gave orange-red 4H, 4H'-octafluoroazobenzene (m.p. = 115-118 °C). Recrystallisation from light petroleum (b.p. 60-80 °C) raised the melting point to 119-120 °C (119-120 °C<sup>144</sup>). Further elution, increasing the proportion of benzene (70-90%) in the eluent gave a blue-green fluorescent solution of 2H, 7H-hexafluorophenazine, which formed a yellow solid, m.p. = 207-208 °C (lit.<sup>144</sup> 208 °C).

#### Preparation of Bamberger's dimer

Bamberger reported<sup>130</sup> a reaction between N-phenylhydroxylamine and formaldehyde to give a dimeric product assigned the structure:

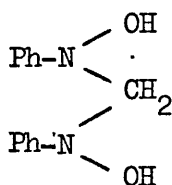

(LIII)

The preparation was repeated. N-Phenylhydroxylamine was made according to Vogel<sup>135</sup>, and 20 g (2 mol) was dissolved in ice-cold ethanol (100 cm<sup>3</sup>) and 40% aqueous formaldehyde (7.5 g, 1 mol) added. After stirring the solution for half an hour a precipitate formed and 800 cm<sup>3</sup> of water were added. After a further half-hour the colourless solid was filtered off, and triturated with ethanol. The elemental analysis agreed with that reported:<sup>130</sup>

C 67.3, H 6.1, N 12.2%. Calc. for (LIII): C 67.8, H 6.1, N 12.2%

However, reaction with lead dioxide (Section 3.12) and the reported<sup>130</sup> tendency to turn yellow on standing (characteristic of N-phenylhydroxylamine) suggest that the material is a mixture of N-phenylhydroxylamine and the bis-nitrone (LII).

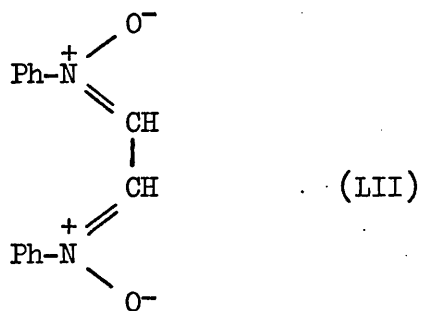

The elemental analysis results are in between the values expected for (LII) and N-phenylhydroxylamine.

Calc. for (LII): C 70.0, H 5.0, N 11.7%

Calc. for PhNHOH: C 66.1, H 6.4, N 12.8%

It has been shown that (LII) is a product of the reaction.<sup>131</sup>

REFERENCES

1. (a) 'Introduction to Magnetic Resonance' by A. Carrington and A.D. McLachlan, Harper, New York, 1967.  
(b) 'Electron Spin Resonance in Chemistry' by P.B. Ayscough, Methuen, London, 1967.  
(c) 'Theory and Interpretation of Magnetic Resonance Spectra' by W.T. Dixon, Plenum, London, 1972.  
(d) 'Electron Spin Resonance', by J.E. Wertz and J.R. Bolton, McGraw-Hill, New York, 1972.  
(e) 'Free Radicals', Vol. II, 435, Ed. J.K. Kochi, Wiley-Interscience, 1973.
2. D.T. Wilkinson and H.R. Crane, Phys. Rev., 1963, 130, 852.
3. A.J. Stone, Proc. Roy. Soc., 1963, A271, 424; Mol. Phys., 1963, 6, 509.
4. T. Yonezawa, I. Noda and T. Kawamura, Bull. Chem. Soc. Jap., 1969, 42, 650.
5. B.G. Segal, M. Kaplan and G.K. Fraenkel, J. Chem. Phys., 1965, 43, 4191.
6. T. Yonezawa, T. Kawamura, M. Ushio and Y. Nakao, Bull. Chem. Soc. Jap., 1970, 43, 1023.
7. T. Kawamura, S. Matsunami and T. Yonezawa, Bull. Chem. Soc. Jap., 1967, 40, 1111.
8. M.S. Blois Jr., H.W. Brown and J.E. Maling, 9th Colloque Ampère, 1960, 243.
9. A.J. Dobbs, Chemical Society Specialist Periodical Reports, Electron Spin Resonance, Vol. 2, Chapter 10.
10. H. Paul and H. Fischer, Helv. Chim. Acta, 1973, 56, 1575.
11. B.G. Gowenlock and G.W. Lüttke, Quart. Reviews, 1958, 12, 321.
12. C. Darwin and D. Hodgkin, Nature, 1950, 166, 827.

13. H. Dietrich and D. Hodgkin, J. Chem. Soc., 1961, 3686.
14. B.G. Gowenlock and J. Trotman, J. Chem. Soc., 1955, 419.
15. B.G. Gowenlock and J. Trotman, J. Chem. Soc., 1956, 1670.
16. R.R. Holmes, R.P. Bayer, L.A. Errede, H.R. Davis, A.W. Wiesenfeld, P.M. Bergman, and D.L. Nicholas, J. Org. Chem., 1965, 30, 3837.
17. R.R. Homes, J. Org. Chem., 1964, 29, 3076.
18. W. Lüttke, Z. Elektrochem., 1957, 61, 982.
19. P. Ehrlich and F. Sachs, Chem. Ber., 1899, 32, 2341.
20. F. Kröhnke and G. Kröhnke, Chem. Ber., 1958, 91, 1474.
21. F. Kröhnke, Angew. Chem., 1963, 75, 181.
22. J. Hamer and A. Macaluso, Chem. Rev., 1964, 64, 473.
23. E.G. Janzen, Acc. Chem. Res., 1971, 4, 31.
24. M.J. Perkins, Chem. Soc. Special Publ., No. 24, Chapter 25.
25. C. Lagercrantz, J. Phys. Chem., 1971, 75, 3466.
26. R.J. Holman, and M.J. Perkins, J. Chem. Soc. (C), 1971, 2324.
27. C. Lagercrantz and K. Torsell, Acta Chem. Scand., 1965, 22, 1935.
28. S. Terabe, K. Kuruma and R. Konaka, J. Chem. Soc., Perkin II, 1973, 1252.
29. S. Terabe and R. Konaka, J. Chem. Soc., Perkin II, 1973, 369; Bull. Chem. Soc. Jap., 1973, 46, 825.
30. A.R. Forrester and S.P. Hepburn, J. Chem. Soc. (C), 1971, 701.
31. E. Bamberger, Ber., 1902, 35, 732.
32. G.A. Russell and E.J. Geels, J. Amer. Chem. Soc., 1965, 87, 122.
33. P.B. Ayscough, F.P. Sargent and R. Wilson, J. Chem. Soc. (B), 1966, 903.
34. F.J. Smentowski, J. Amer. Chem. Soc., 1963, 85, 3036.
35. C.J.W. Gutch and W.A. Waters, Proc. Chem. Soc., 1964, 230.



36. G.K. Fraenkel and J. Gendell, J. Chem. Phys., 1962, 37, 2832.
37. E.J. Geels, R. Konaka and G.A. Russell, Chem. Comm., 1965, 13.
38. D.H. Levy and R.J. Myers, J. Chem. Phys., 1965, 42, 3731.
39. G.A. Russell, E.J. Geels, F.J. Smentowski, K.-Y. Chang, J. Reynolds and G. Kaupp, J. Amer. Chem. Soc., 1967, 89, 3821.
40. J.C. Baird and J.R. Thomas, J. Chem. Soc., 1961, 35, 1507.
41. K. Maruyama and T. Otsuki, Tet. Let., 1966, 3705.
42. K. Maruyama and T. Otsuki and T. Iwao, J. Org. Chem., 1967, 32, 82.
43. D. Mulvey and W.A. Waters, J. Chem. Soc., Perkin II, 1974, 772.
44. W.C. Danen, C.T. West, and T.T. Kensler, J. Amer. Chem. Soc., 1973, 95, 5716.
45. J. Hutton and W.A. Waters, J. Chem. Soc. (B), 1968, 191.
46. F. Zavattorelli, I.R. Bellobono and P.L. Beltrame, J. Chem. Soc., Perkin II, 1974, 983.
47. H.G. Aurich and W. Dersch, Z. Naturforsch. 1973, 28b, 525.
48. G.A. Russell and E.G. Janzen, J. Amer. Chem. Soc., 1962, 84, 4153.
49. G.A. Russell, E.G. Janzen and E.T. Strom, J. Amer. Chem. Soc., 1962, 84, 4155.
50. G.A. Russell, E.G. Janzen and E.T. Strom, J. Amer. Chem. Soc., 1964, 86, 1807.
51. 'Free Radicals' Ed. J.K. Kochi, Vol. 1, Chapter 9, J.F. Garst.
52. J.F. Garst, Acc. Chem. Res., 1971, 4, 400.
53. J. San Filippo Jr., C.-I. Cheru and J.S. Valentine, J. Org. Chem., 1975, 40, 1678.  
R.A. Johnson and E.G. Nidy, ibid., 1975, 40, 1678.  
W.C. Danen and R.J. Warner, Tet. Let., 1977, 989.

54. E. Lee-Ruff, Chemical Society Reviews, 1977, 6, 195.
55. N. Kornblum, Angew. Internat. Ed., 1975, 14, 734.
56. G.A. Russell, Chem. Soc. Special Publ. No. 24, 1970, 271.
57. J.K. Kim and J.F. Bunnett, J. Amer. Chem. Soc., 1970, 92, 7463.
58. J.A. Zoltewicz, 'Topics in Current Chemistry', 1975, 59, 33.
59. S. Bank and D.A. Noyd, J. Amer. Chem. Soc., 1973, 95, 8203.
60. M.P. Crozet, E. Flesia and J.-M. Surzur, Annual Chemical Congress, York Univ., 1975.
61. O.H. Griffith, D.W. Cornell and H.M. McConnell, J. Chem. Phys., 1965, 43, 2909.
62. J.H. Freed and G.K. Fraenkel, J. Chem. Phys., 1964, 40, 1815.
63. A. Calder, A.R. Forrester, J.W. Emsley, G.D. Luckhurst and R.A. Storey, Mol. Phys., 1970, 18, 481.
64. J.A. Pedersen and K. Torsell, Acta Chem. Scand., 1971, 25, 3151.
65. J. Goldman, T.E. Petersen and K. Torsell, Tetrahedron, 1973, 29, 3833.
66. T. Kitagana, T.P. Layloff and R.N. Adams, Anal. Chem., 1963, 35, 1086.
67. A.R. Metcalfe and W.A. Waters, J. Chem. Soc. (B), 1969, 918.
68. J.F. Bunnett, J. Chem. Ed., 1974, 51, 312.
69. H. Riederer, J. Hüttermann and M.C.R. Symons, J.C.S. Chem. Comm., 1978, 313.
70. D.H. Geske, J. L. Ragle, M.A. Bamberck and A.L. Balch, J. Amer. Chem. Soc., 1964, 86, 987.
71. M.E. Peover and B.S. White, J.C.S. Chem. Comm., 1965, 183.
72. R. Poupko and I. Rosenthal, J. Phys. Chem., 1973, 77, 1722.
73. J. Burdon and D.F. Thomas, Tetrahedron, 1965, 2389.
74. B. Venkataraman and G.K. Fraenkel, J. Amer. Chem. Soc., 1955, 77, 2707.

75. B. Venkataraman, B.G. Segal and G.K. Fraenkel, J. Chem. Phys., 1959, 30, 1006.
76. P. Ashworth and W.T. Dixon, J. Chem. Soc. Perkin II, 1972, 1130 and 2264.
77. Y. Matsunaga and C.A. McDowell, Can. J. Chem., 1960, 38, 1167.
78. R.E. Banks, R.N. Haszeldine, E. Philips and I.M. Young, J. Chem. Soc. (C), 1967, 2091.
79. C.L. Greenstock, I. Dunlop and P. Neta, J. Phys. Chem., 1973, 77, 1187.
80. J.L. Gerlock and E.G. Janzen, J. Amer. Chem. Soc., 1968, 90, 1652.
81. J.L. Gerlock, E.G. Janzen and J.K. Ruff, J. Amer. Chem. Soc., 1970, 92, 2558.
82. V.A. Ginsburg, A.N. Medvedev, S.S. Dubov and M.F. Lebedeva, Zhur. Obshchei Khim., 1967, 37, 601.  
V.A. Ginsburg, A.N. Medvedev, M.F. Lebedeva, M.N. Vasilleva and L.L. Martynova, ibid. 1967, 37, 611.  
V.A. Ginsburg, V.V. Smolyanitskaya, A.N. Medvedev, V.S. Faermark and A.P. Tomilov, ibid., 1971, 41, 2284.
83. G.A. Russell, R. Konaka, E.T. Strom, W.C. Danen, K.-Y. Chang and G. Kaupp, J. Amer. Chem. Soc., 1968, 90, 4646.
84. F.A. Neugebauer and H. Weger, Chem. Ber., 1975, 108, 2703.
85. D.H. Geske and G.R. Padmanabhan, J. Amer. Chem. Soc., 1965, 87, 1651.
86. R. Wilson and D. Kivelson, J. Chem. Phys., 1966, 44, 145.
87. P.B. Ayscough, F.P. Sargent and R. Wilson, J. Chem. Soc., 1963, 5418.
88. A. Carrington, A. Hudson and G.R. Luckhurst, Proc. Roy. Soc., 1965, A284, 582.
89. J.H. Freed and G.K. Fraenkel, J. Chem. Phys., 1963, 39, 326.
90. 'Electron Spin Resonance', Chapter 9, by N.M. Atherton, John Wiley, 1973.

91. J.R. Bolton and G.K. Fraenkel, J. Chem. Phys., 1964, 41, 944.
92. G. Chapelet-Letourneux, H. Lemaire and A. Rassat, Bull. Soc. Chem. France, 1965, 3283.
93. W.T. Dixon, R.O.C. Norman and A.L. Buley, J. Chem. Soc., 1964, 3625.
94. H. Lemaire and A. Rassat, J. Chim. Phys., 1964, 61, 1580.
95. D.H. Geske, Prog. Phys. Org. Chem., 1967, 4, 125.
96. I.I. Bilkis and S.M. Shein, Tetrahedron, 1975, 969.
97. C. Lagercrantz and M. Setaka, Acta Chem. Scand., 1974, B28, 619.
98. 'Organic Chemistry of Stable Free Radicals', by A.R. Forrester, J.M. Hay and R.H. Thomson, 1968.
99. A.K. Hoffmann, W.G. Hodgson, D.L. Maricle and W.H. Jura, J. Amer. Chem. Soc., 1964, 86, 631.
100. A.K. Hoffmann, A.M. Feldman, E. Gelblum and W.G. Hodgson, J. Amer. Chem. Soc., 1964, 86, 639.
101. R. Brière and A. Rassat, Bull. Chim. Soc., France, 1965, 378.  
F. McCapra, Quart. Rev., 1966, 20, 485.
102. P. Neta and R.W. Fessenden, J. Phys. Chem., 1974, 78, 523.
103. W.T. Dixon and D. Murphy, J. Chem. Soc., Perkin II, 1974, 1630.
104. D.H. Geske and A.H. Maki, J. Amer. Chem. Soc., 1960, 82, 2671.
105. M. Lipsztajn, T.M. Krygowski, E. Laren and Z. Galns, J. Electroanalytical Chem., 1974, 57, 339.
106. W. Kemula and R. Sioda, J. Electroanalytical Chem., 1963, 6, 183.
107. H. Lund, M.-A. Michel and J. Simonet, Acta Chem. Scand., 1974, B28, 900.
108. J. Koutecký and J. Cizek, J. Collect. Czech. Chem. Commun., 1956, 21, 1063.
109. 'Introduction to Organic Electrochemistry' by M.R. Rifi and F.H. Covitz, 1975.

110. A. Mathias and E. Warhurst, Trans. Faraday Soc., 1962, 58, 942.
111. 'Free Radicals', Ed. J.K. Kochi, Vol. 1, Chapter 2, by K.U. Ingold.
112. E.M. Kosower and E.J. Poziomek, J. Amer. Chem. Soc., 1964, 86, 5515.
113. C.S. Johnson and H.S. Gutowsky, J. Chem. Phys., 1963, 39, 58.
114. 'Heterocyclic Compounds, Pyridine and its derivatives', Part 2, Chapter 3, E.N. Shaw; Vol. 14, Part 1 supplement, Chapter 3 (1974), O.R. Rodig and references therein.
115. M.P. Crozet, E. Flesia, J.-M. Surzur, M. Boyer and P. Tordo, Tet. Let., 1975, 4563.
116. T. Kauffmann and S.H. Hage, Angew. Chem. Internat. Ed., 1963, 2, 156.
117. 'Practical Polarography', by J. Heyrovsky and P. Zuman, 1968.
118. G. Cauquis, M. Genies, H. Lemaire, A. Rassat and J.P. Ravet, J. Chem. Phys., 1967, 47, 4642.
119. S. Terabe and R. Konaka, J. Chem. Soc., Perkin II, 1973, 369.
120. J.F. Bunnett, J.H. Miles and K.V. Nahabedian, J. Amer. Chem. Soc., 1961, 83, 2512.
121. 'Sidgwick's Organic Chemistry of Nitrogen', Revised by I.T. Millar and H.D. Springall, 1969.
122. J.H. Osiecki and E.F. Ullman, J. Amer. Chem. Soc., 1968, 90, 1078.  
D.G.B. Boocock, R. Darcy and E.F. Ullman, ibid., 1968, 90, 5945.  
D.G.B. Boocock and E.F. Ullman, ibid. 1968, 90, 6873.  
E.F. Ullman, L.-Call and J.H. Osiecki, J. Org. Chem., 1970, 35, 3623.
123. H.G. Aurich and K. Stork, Chem. Ber., 1975, 108, 2764.
124. H.G. Aurich and P. Höhle, Tet. Let., 1974, 279.
125. H.G. Aurich and F. Baer, Chem. Ber., 1968, 1761.

126. 'Principles of Polarography', by J. Heyrovsky and J. Kuta, 1966, 550.
127. C.M. Camaggi, R.J. Holman and M.J. Perkins, J. Chem. Soc., Perkin II, 1972, 501.
128. A. Calder, A.R. Forrester and S.P. Hepburn, J. Chem. Soc. Perkin I, 1973, 456.
129. J.E. Baldwin, A.K. Qureshi and B. Sklarz, J. Chem. Soc. (C), 1969, 1073.
130. E. Bamberger, Ber., 1900, 33, 941.
131. G.E. Utzinger and F.A. Regenass, Helv. Chim. Acta., 1954, 37, 1892.
132. J.Q. Adams and J.R. Thomas, J. Chem. Phys., 1964, 39, 1904.
133. R.D. Allendoerfer, J. Chem. Phys., 1971, 55, 3615.
134. B.G. Segal, M. Kaplan and G.K. Fraenkel, J. Chem. Phys., 1965, 43, 4191.
135. 'Practical Organic Chemistry', by A.I. Vogel, 3rd Ed., 630.
136. R.R. Holmes and R.P. Bayer, J. Amer. Chem. Soc., 1960, 82, 3455.
137. L. DiNunno, S. Florio and P.E. Todesco, J. Chem. Soc. (C), 1970, 1433.
138. H. von Pechmann and A. Nold, Ber., 1898, 31, 562.
139. R. Okazaki, T. Hosogai, E. Iwadare and M. Hashimoto, Bull. Chem. Soc. Jap., 1969, 42, 3611.
140. E. Bamberger and A. Rising, Ber., 1900, 33, 3632.
141. R.C. Barclay and E.E. Betts, Can. J. Chem. 1955, 33, 672.
142. J. Burgers, M.A. Hoefnagel, P.E. Verkade, H. Visser and B.M. Wepster, Rec. Trav. Chim., 1958, 77, 491.
143. J. Burdon, C.J. Morton and D.F. Thomas, J. Chem. Soc., 1965, 2621.
144. J.M. Birchall, R.N. Haszeldine and J.E.G. Kemp, J. Chem. Soc. (C) 1970, 449.