

## Introduction

Resource theories of language performance in aphasia are based largely on data generated by dual-task methods (Blackwell & Bates, 1995; Caplan & Waters, 1996; Murray et al., 1997; Tseng, McNeil & Milenkovic et al., 1993). The central bottleneck (CB) model (Pashler, 1994; Welford, 1952), is an alternative model of dual-task performance that attributes dual-task performance decrements to a single-channel limit on central processing operations broadly conceived as response selection, rather than on capacity limitations or failures to optimally allocate that resources. On this view, response selection proceeds for only one task at a time while perceptual analysis and response execution stages of proceed concurrently. Many studies have demonstrated findings consistent with this model: When discrete stimulus-response tasks are presented at varying stimulus onset asynchronies (SOAs), the reaction time to the second task (RT2) slows as SOA is reduced, a phenomenon referred to as the psychological refractory period (PRP) effect (Pashler, 1994). Also, increasing the difficulty of central stages of the primary task results in additive slowing of RT2 (see Figure 1) (e.g., Carrier & Pashler, 1995; Fagot & Pashler, 1992; Smith, 1969). The CB model also predicts that primary task reaction times (RT1) will be unaffected by SOA or secondary-task factors; a frequent, but not ubiquitous result in PRP dual-task studies (Navon & Miller, 2002).

Recently, a mathematically specified capacity-sharing model has been proposed to account for the RT effects observed using the PRP method (Navon & Miller, 2002; Tombu & Jolicoeur, 2003). This model (Figure 2) proposes that central stages of competing tasks proceed in parallel, but with reduced efficiency because of a limited supply of central processing resources. Under extreme allocation ratios favoring the primary task, the capacity model makes predictions identical to the bottleneck model. If the proportion of capacity allocated to the primary task is  $<1$ , however, the capacity model predicts that RT1 will rise with decreasing SOA and that task 1 difficulty manipulations will have a larger effect on RT1 at shorter SOAs.

A PRP dual-task experiment modeled on Ferreira and Pashler (2002) was conducted to evaluate whether the bottleneck or capacity model better accounts for RTs in concurrent tasks. Cloze picture-naming was the primary task, and either a tone or lexical category identification was the secondary task. It was predicted that the lexical secondary task would promote resource sharing, causing an SOA-by-secondary-task interaction on RT1, with longer cloze naming RTs at short SOAs in the lexical-secondary condition. It was also predicted that the cloze-constraint manipulation would have a larger effect on naming RTs at short SOAs in the lexical-secondary conditions only.

## Method

Subjects were 20 adults, age 52-82 (mean=67, sd=9.6) who passed hearing, vision, memory, and language screens, and reported no history of communication, neurological, or psychiatric disorder.

Picture stimuli (n=60) and cloze sentences were taken from Griffin and Bock (1998). The cloze sentences were spoken by a female speaker, and the word stimuli by a male speaker. There were 60 word stimuli in four categories: kitchen utensils, clothing, transportation, and furniture. The word lists for each category were balanced for lexical frequency, category dominance, typicality, length, and duration. Tone stimuli were 180Hz, 500Hz, and 1200Hz pure tones, 305 ms in length. Naming responses were collected by voice key and word identification responses by keypad.

On each trial, subjects heard a cloze sentence that was either highly constraining for the picture stimulus (e.g., “The pitcher threw the...”) or unconstraining (e.g., “The display contained a...”), and then saw the corresponding picture (a ball). Subjects were asked to name the picture. The picture was followed 50ms, 150ms, or 900ms later by a tone or a word. Subjects were instructed to press a button indicating whether the tone was high or low in pitch, or which of two categories the word belonged to. Subjects were instructed to respond to both stimuli as quickly as possible, and name the picture first on every trial.

Subjects saw each picture twice, once with a highly constraining sentence, and once with low constraint. Trials were presented in four blocks of 30 trials each. On two blocks the secondary auditory ID stimulus was a tone and on two blocks it was a word. The constraint conditions were balanced across SOA, and presented in pseudorandom order. The order of secondary tasks was counterbalanced across subjects, and within blocks the categories were balanced across SOA and constraint. No secondary stimulus word was phonologically or semantically related to the picture stimulus for that trial, nor to any word in the cloze sentence. Prior to the experimental trials, subjects named each picture twice with feedback, and performed one block of 20 dual-task trials using different stimuli. Before each block of experimental trials, subjects practiced the secondary auditory ID task for that block in isolation using the experimental stimuli.

## **Results**

Trials containing voice key failures, errors, or RT outliers were excluded from analysis. Data from eight subjects were excluded from the analysis because their RTs suggested that they did not follow instructions to respond to the primary task as quickly as possible. These subjects demonstrated naming RTs that rose with SOA, with average RTs >900ms in the 900ms SOA condition, suggesting that they were waiting until presentation of the secondary task to respond to the primary task.

The RT data for the naming task are presented in Figure 3. Subjects’ mean RTs were submitted to an ANOVA with three repeated factors: secondary task type (tone vs. category ID), naming constraint (high, low), and SOA (50, 150, 900ms). The alpha level was set at 0.10, because the effects predicted by the resource model are potentially small, though theoretically important. All three main effects were significant ( $p < 0.01$ ) in the predicted direction, with longer RTs observed for the semantic ID, low constraint, and short SOA conditions. Also the secondary task type-by-SOA interaction was significant ( $p < .001$ ), which is consistent with the impression from Figure 3 that SOA affected naming RTs in the semantic ID conditions, but not the tone ID conditions. Finally, the three-way interaction was significant ( $p = 0.063$ ), which is consistent with the observation that the constraint effect on semantic identification trials was largest at 50ms SOA, but largest for tone ID trials at 900ms SOA.

Reaction time means for the secondary, auditory identification task are presented in Figure 4. These data were submitted to an ANOVA identical to the one described above. Again, all three main effects were significant ( $p < 0.001$ ) in the predicted direction. The constraint-by-SOA interaction was significant ( $p = 0.04$ ), due to larger differences between constraint conditions at shorter SOAs. The three-way interaction was also significant ( $p < 0.004$ ), consistent with the observation that the constraint effect for semantic ID trials was larger at 50ms SOA than 150 or 900ms, while the constraint effect for tone ID trials was more consistent across SOA conditions.

## **Discussion**

The present data are more consistent with the central capacity than the central bottleneck model. In particular, the observation that primary-task naming RTs rose with decreasing SOA in the lexical category, but not the tone ID conditions was predicted by the capacity model and is inconsistent with the bottleneck model. The observed three-way interaction on primary-task naming RTs lends further support to the capacity model.

#### References

Blackwell, A. & Bates, E. (1995). Inducing agrammatic profiles in normals: Evidence for the selective vulnerability of morphology under cognitive resource limitation. *Journal of Cognitive Neuroscience*, 7, 228-257.

Caplan, D. & Waters, G. S. (1996). Syntactic processing in sentence comprehension under dual-task conditions in aphasic patients. *Language and Cognitive Processes*, 11, 525-551.

Carrier, L. M. & Pashler, H. (1995). Attentional limits in memory retrieval. *Journal of Experimental Psychology: Learning, Memory, and Cognition*, 21, 1339-1348.

Fagot, C. & Pashler, H. (1992). Making two responses to a single object: Implications for the central attentional bottleneck. *Journal of Experimental Psychology: Human Perception and Performance*, 18, 1058-1079.

Ferreira, V. S. & Pashler, H. (2002). Central bottleneck influences on the processing stages of word production. *Journal of Experimental Psychology: Learning, Memory, and Cognition*, 28, 1187-1199.

Griffin, Z. M. & Bock, K. (1998). Constraint word frequency, and the relationship between lexical processing levels in spoken word production. *Journal of Memory and Language*, 38, 313-338.

Murray, L. L., Holland, A. L., & Beeson, P. M. (1997). Auditory processing in individuals with mild aphasia: a study of resource allocation. *Journal of Speech, Language, and Hearing Research, 40*, 792-808.

Navon, D. & Miller, J. (2002). Queuing or sharing? A critical evaluation of the single-bottleneck notion. *Cognitive Psychology, 44*, 193-251.

Pashler, H. (1994). Dual-task interference in simple tasks: Data and theory. *Psychological Bulletin, 116*, 220-244.

Smith, M. C. (1969). The effect of varying information on the psychological refractory period. *Acta Psychologica, 30*, 220-231.

Tombu, M. & Jolicoeur, P. (2003). A central capacity sharing model of dual-task performance. *Journal of Experimental Psychology: Human Perception and Performance, 29*, 3-18.

Tseng, C. H., McNeil, M. R., & Milenkovic, P. (1993). An investigation of attention allocation deficits in aphasia. *Brain and Language, 45*, 276-296.

Welford, A. T. (1952). The "psychological refractory period" and the timing of high speed performance: A review and theory. *British Journal of Psychology, 43*, 2-19.

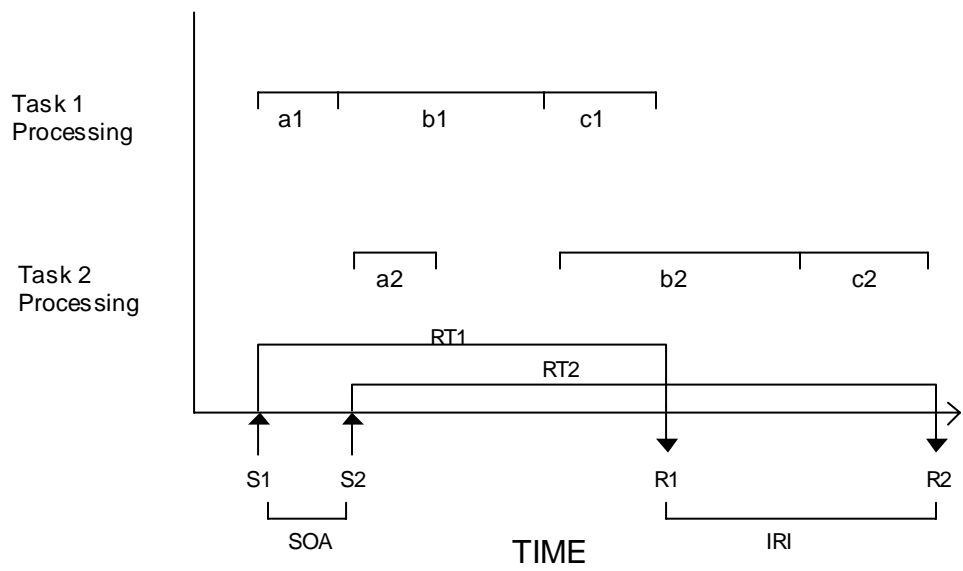

Figure 1. A time diagram for the Single-Bottleneck Model, taken from Navon and Miller (2002, p. 228). a1, a2 represent perceptual processing of Tasks 1 and 2, respectively; b1, b2 represent central or response selection processing of Tasks 1 and 2; c1, c2 represent the response execution stages of each task; S1, S2 indicate stimulus presentation for each task; SOA = stimulus onset asynchrony; R1, R2 indicate task responses; RT1, RT2 = individual task reaction times; IRI = inter-response interval

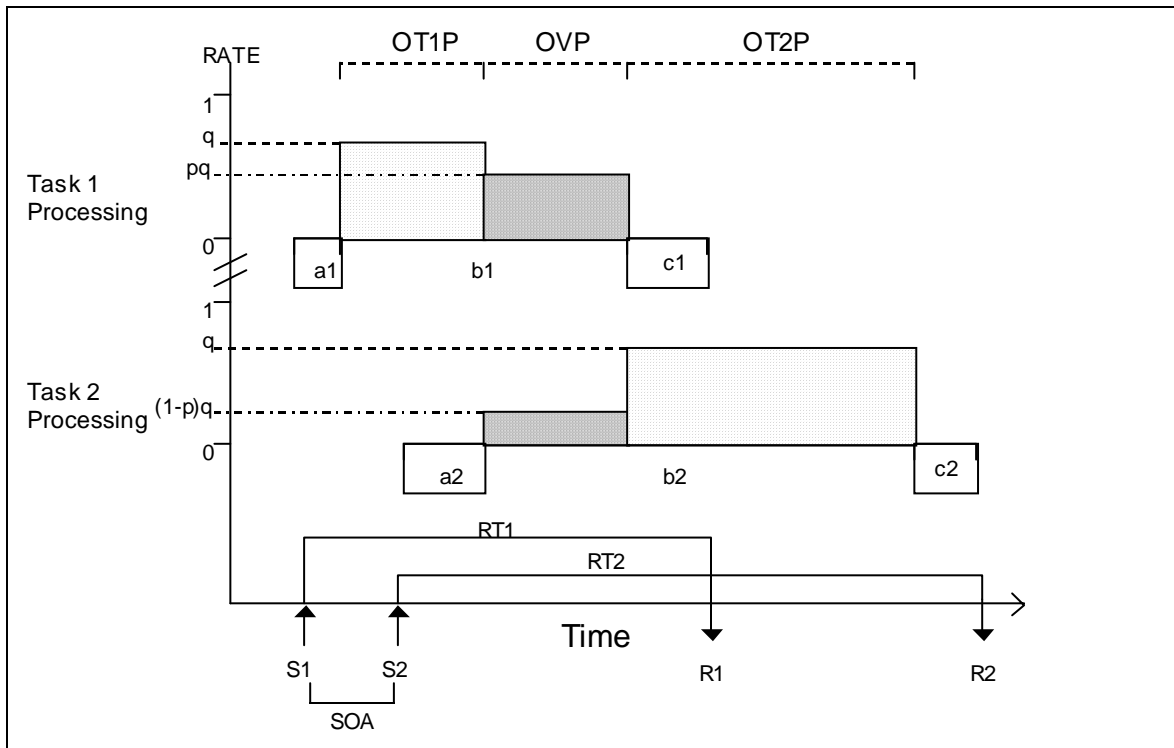

Figure 2. A time diagram of the central resource model, taken from Navon and Miller (2002, p. 232). Abbreviations are the same as Figure 1., with the following additions: 1 = total resource capacity available under ideal conditions;  $q$  = resource capacity available on a given trial;  $p$  = task 1 allocation ratio; OT1P = period during which the resource-limited stage of only task 1 is processed; OT2P = corresponding period for task 2; OVP = the overlap period during which resource-limited processing for both tasks is carried out.

Figure 3. Mean primary-task naming RTs by condition. Error bars indicate one standard error.

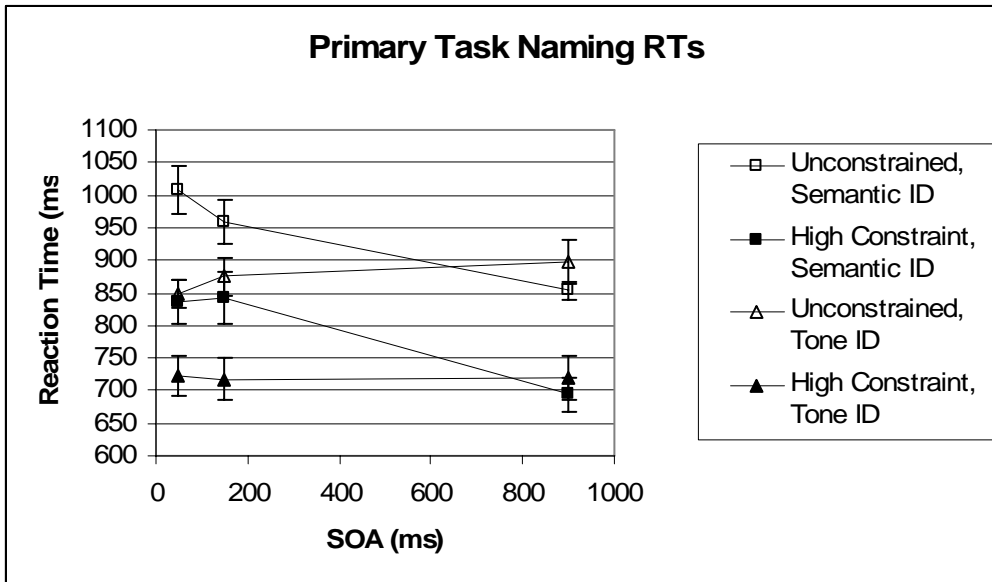
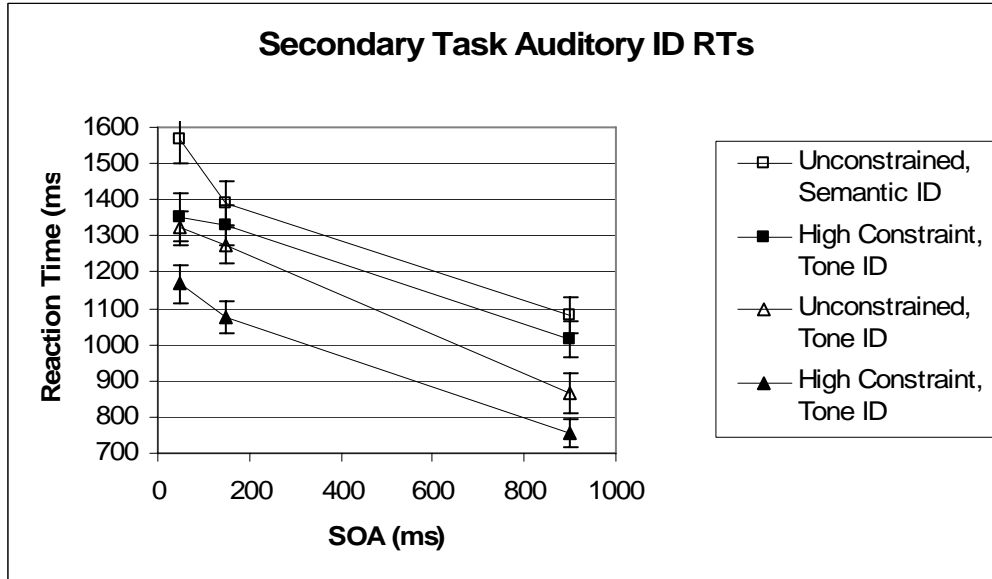

Figure 4. Mean secondary task RTs (semantic category ID or tone ID) by condition.



Error bars indicate one standard error.